



Committee of Experts on the Transport of Dangerous Goods and on the Globally Harmonized System of Classification and Labelling of Chemicals

Sub-Committee of Experts on the Transport of Dangerous Goods

Fifty-seventh session

Geneva, 29 June-8 July 2020

Item 2 (g) of the provisional agenda

Explosives and related matters:

test N.1 for readily combustible solids

Proposals to amend Figure 33.2.4.1:(A) cross-section of the 250 mm long mould in the Manual of Tests and Criteria

Transmitted by the expert from China*

Introduction

1. After reviewing section 33.2.4.2 in the Manual of Tests and Criteria (ST/SG/AC.10/11/Rev.7) and regarding the mould for burning rate test, particularly Figure 33.2.4.1, experts from China have identified some deficiencies in the cross-section diagram of 250 mm long mould which need to be revised to ensure that the information corresponds to the description in 33.2.4.2.
2. The Figure 33.2.4.1:(A) is the cross-section of mould which indicates the inner structure. With this cross-section diagram, the experiment researcher shall make the mould correctly.

Necessity of revision

3. In section 33.2.4.2 - apparatus and materials, a mould 250 mm long with a triangular cross-section of inner height 10 mm and width 20 mm is used to form the train for the burning rate test. But in Figure 33.2.4.1:(A), the 20 mm width includes the thickness of the metal sheets on both sides as lateral limitation, therefore the width of triangle of the mould can only be less than 20 mm.
4. According to the description in section 33.2.4.2, Figure 33.2.4.1 shows the cross section of the mould without samples. In Figure 33.2.4.1:(A), there are two transverse lines on top which seem to indicate a lateral limitation in the transversal direction. But this lateral limitation in transversal direction covered some parts of lateral limitations in longitudinal direction.

* 2020 (A/74/6 (Sect.20) and Supplementary, Subprogramme 2)

5. Figure 33.2.4.1:(A) is not a real cross section of the mould. It includes both triangular cross-section and lateral limitation in the transversal direction may cause confusion to the experiment researcher. The purpose of using such a diagram seems to be consistent with the style of Figure 33.2.4.1 which using perspective to express more information.

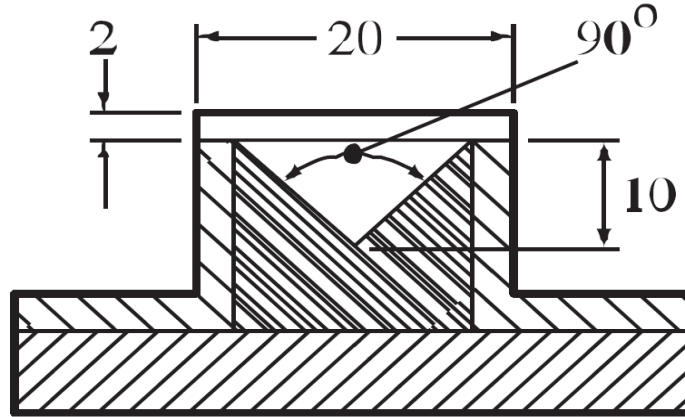

A

Proposal

6. The experts from China propose 3 options to amend Figure 33.2.4.1:(A) as follows:

Option 1

Revise the 20 mm width marking in Figure 33.2.4.1:(A) to exclude the thickness of the two metal sheets. In order to show the lateral limitation in the transversal direction with perspective and keep the original style, revise the width of the transverse lines on top of the triangle to exclude the two metal sheets. (Figure 1)

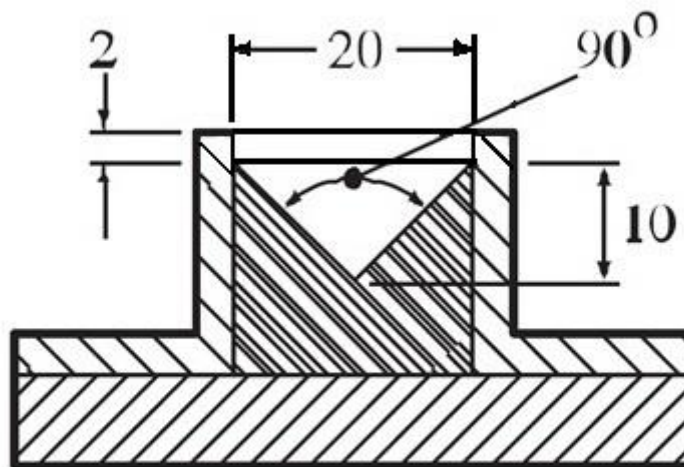

A

Figure1

Option 2

Revise the 20 mm width marking in Figure 33.2.4.1:(A) to exclude the thickness of the two metal sheets. Remove the transverse lines on top of the triangle in Figure 33.2.4.1:(A) consistent with the actual situation. (Figure 2)

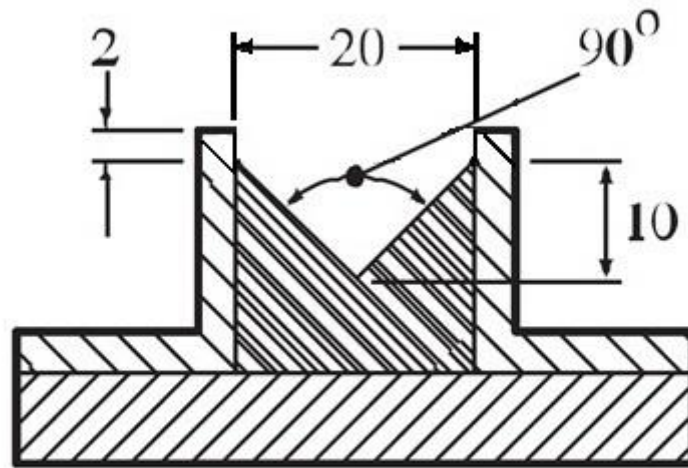

A

Figure2

Option 3

Replace the Figure 33.2.4.1:(A) with a new figure to bring more details which contain top view, end face view, sectional view and side view of the mould. (Figure 3)

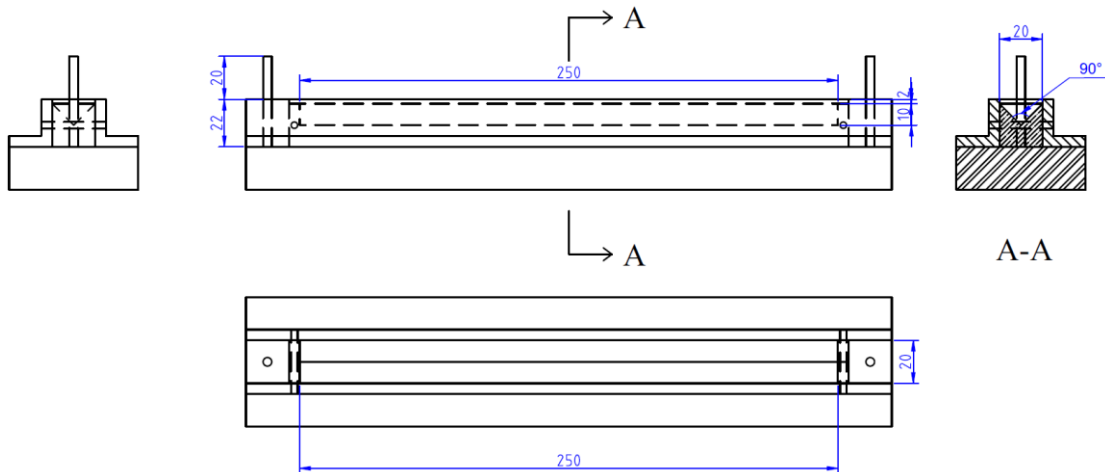

Figure 3