

Proposal for the 03 series of amendments to UN Regulation No. 100 (Specific requirements for the electric power train)

Submitted by the experts from Japan on behalf of Task Force

The text reproduced below has been prepared by the experts from Japan on behalf of Task Force to amend the requirements concerning specific requirements for the electric power train. The modifications to the current text of the Regulation and to the proposal are marked in bold for new or strikethrough for deleted characters.

I. Proposal

Text of the UN Regulation,

Through all text of the Regulation (including all Annexes), tested-device, amend to read:
Tested-Device.

Paragraphs 1.1. to 1.2., amend to read:

"1.1. Part I: Safety requirements with respect to the electric power train of road vehicles of categories M and N¹, with a maximum design speed exceeding 25 km/h, equipped with **electric power train, excluding vehicles permanently connected to the grid** ~~one or more traction motor(s) operated by electric power and not permanently connected to the grid, as well as their high voltage components and systems which are galvanically connected to the high voltage bus of the electric power train.~~

Part I of this regulation does not cover; ~~post-crash safety requirements of road vehicles.~~

- (a) **Post-crash safety requirements of road vehicles.**
- (b) **High voltage components and systems which are not galvanically connected to the high voltage bus of the electric power train.**

1.2. Part II: Safety requirements with respect to the Rechargeable Electrical Energy Storage System (REESS), of road vehicles of categories M and N equipped with **electric power train, excluding vehicles** ~~one or more traction motors operated by electric power and not permanently connected to the grid.~~

Part II of this Regulation does not apply to **a battery REESS(s)** whose primary use is to supply power for starting the engine and/or lighting and/or other vehicle auxiliaries' systems. **[Primary use in this context means that more than 50% of the energy from the battery is used for starting the engine and/or lighting and/or other vehicle auxiliaries' systems over an appropriate driving cycle, e.g. WLTC for M1 and N1.]**"

Remove (former) Paragraphs 2.2.

Insert new Paragraphs 2.2. to 2.4., to read:

"2.2. **"Aqueous electrolyte" means an electrolyte based on water solvent for the compounds (e.g. acids, bases) providing conducting ions after its dissociation.**

¹ As defined in the Consolidated Resolution on the Construction of Vehicles (R.E.3.), document ECE/TRANS/WP.29/78/Rev.2, para. 2.

2.3. "Automatic disconnect" means a device that when triggered, conductively separates the electric energy sources from the rest of the high voltage circuit of the electric power train.

2.4. "Breakout harness" means connector wires that are connected for testing purposes to the REESS on the traction side of the automatic disconnect."

ReNUMBER (former) Paragraph 2.3. as Paragraph 2.5., and amend to read:

"2.5. "Cell" means a single enclosed electrochemical unit containing one positive and one negative terminals-electrode, which exhibits a voltage differential across its two terminals and used as rechargeable electrical energy storage device."

ReNUMBER (former) Paragraph 2.4. as Paragraph 2.6.

Insert new Paragraph 2.7., to read:

"2.7. "Connector" means the device providing mechanical connection and disconnection of high voltage electrical conductors to a suitable mating component including its housing."

ReNUMBER (former) Paragraphs 2.5. to 2.6. as Paragraphs 2.8. to 2.9.

ReNUMBER (former) Paragraph 2.7. as Paragraph 2.10., and amend to read:

"2.10. "Direct contact" means the contact of persons with high voltage live parts."

ReNUMBER (former) Paragraph 2.10. as Paragraph 2.11., and amend to read:

"2.11. "Electric energy conversion system" means a system (e.g. fuel cell) that generates and provides electric energy for electric propulsion."

ReNUMBER (former) Paragraph 2.11. as Paragraph 2.12.

ReNUMBER (former) Paragraph 2.8. as Paragraph 2.13.

ReNUMBER (former) Paragraph 2.9. as Paragraph 2.14., and amend to read:

"2.14. "Electrical circuit" means an assembly of connected high voltage live parts which is designed to be electrically energized in normal operation."

Insert new Paragraphs 2.15 to 2.16., to read:

"2.15. "Electrical protection barrier" means the part providing protection against direct contact to the high voltage live parts.

2.16. "Electrolyte leakage" means the escape of electrolyte from the REESS in the form of liquid."

ReNUMBER (former) Paragraph 2.12. as Paragraph 2.17.

ReNUMBER (former) Paragraph 2.13. as Paragraph 2.18., and amend to read:

"2.18. "Enclosure" means the part enclosing the internal units and providing protection against any direct contact from any direction of access."

ReNUMBER (former) Paragraph 2.15. as Paragraph 2.19.

ReNUMBER (former) Paragraph 2.14. as Paragraph 2.20., and amend to read:

"2.20. "Exposed conductive part" means the conductive part which can be touched under the provisions of the protection degree IPXXB, and which is not

normally energized, but which can become ~~becomes~~ electrically energized under isolation failure conditions. This includes parts under a cover that can be removed without using tools."

Renumber (former) Paragraph 2.16. as Paragraph 2.21.

Renumber (former) Paragraphs 2.18. to 2.19. as Paragraphs 2.22. to 2.23.

Renumber (former) Paragraph 2.17. as Paragraphs 2.24.

Renumber (former) Paragraph 2.20. as Paragraph 2.25., and amend to read:

"2.25. "High voltage bus" means the electrical circuit, including the coupling system for charging the REESS that operates on high voltage. ~~Where~~ **In case of** electrical circuits, that are galvanically connected to each other ~~are galvanically connected to the electrical chassis and the maximum voltage between any live part and the electrical chassis or any exposed conductive part is ≤ 30 V AC and ≤ 60 V DC,~~ **and fulfilling the voltage condition specified in paragraph 2.42.,** only the components or parts of the electric circuit that operate on high voltage are classified as a high voltage bus."

Renumber (former) Paragraph 2.21. as Paragraph 2.26.

Renumber (former) Paragraph 2.22. as Paragraph 2.27., and amend to read:

"2.27. "Live parts" means the conductive part(s) intended to be electrically energized **under normal operating conditions** ~~in normal use.~~"

Renumber (former) Paragraphs 2.23. to 2.24. as Paragraphs 2.28. to 2.29., and amend to read:

"2.28. "Luggage compartment" means the space in the vehicle for luggage accommodation, bounded by the roof, hood, floor, side walls, as well as by the barrier and enclosure provided for protecting the occupants from direct contact with **high voltage** live parts, being separated from the passenger compartment by the front bulkhead or the rear bulk head.

2.29. "Manufacturer" means the person or body who is responsible to the approval authority for all aspects of the ~~type~~ approval process and for ensuring conformity of production. It is not essential that the person or body ~~be~~ **is** directly involved in all stages of the construction of the vehicle, ~~system~~ or component which is the subject of the approval process."

Insert new Paragraphs 2.30. to 2.31., to read:

"2.30. "Non-aqueous electrolyte" means an electrolyte not based on water as the solvent.

2.31. "**Normal operating conditions**" includes operating modes and conditions that can reasonably be encountered during typical operation of the vehicle including driving at legally posted speeds, parking and standing in traffic, as well as, charging using chargers that are compatible with the specific charging ports installed on the vehicle. It does not include conditions where the vehicle is damaged, either by a crash, road debris or vandalism, subjected to fire or water submersion, or in a state where service and or maintenance is needed or being performed."

Renumber (former) Paragraph 2.25. as Paragraph 2.32.

Renumber (former) Paragraphs 2.26. to 2.27. as Paragraphs 2.33. to 2.34., and amend to read:

- "2.33. "Open type traction battery" means a ~~liquid~~-type of battery requiring filling with ~~water~~-**liquid** and generating hydrogen gas **that is** released to the atmosphere.
- 2.34. "Passenger compartment" means the space for occupant accommodation, bounded by the roof, floor, side walls, doors, ~~window glass~~**outside glazing**, front bulkhead and rear bulkhead, or rear gate, as well as by the **electrical protection** barriers and enclosures provided for protecting the occupants from direct contact with **high voltage** live parts."

Remove (former) Paragraph 2.28.

Insert new Paragraphs 2.35. and 2.36., to read:

- "2.35. "Protection degree IPXXB" means protection from contact with high voltage live parts provided by either an electrical protection barrier or an enclosure and tested using a Jointed Test Finger (IPXXB) as described in Annex 3.
- 2.36. "Protection degree IPXXD" means protection from contact with high voltage live parts provided by either an electrical protection barrier or an enclosure and tested using a Test Wire (IPXXD) as described in Annex 3."

Renumber (former) Paragraph 2.29. as Paragraph 2.37., and amend to read:

- "2.37. "Rechargeable Electrical Energy Storage System (REESS)" means the rechargeable energy storage system that provides electric energy for electric propulsion.

A battery whose primary use is to supply power for starting the engine and/or lighting and/or other vehicle auxiliaries' systems is not considered as a REESS. [Primary use in this context means that more than 50% of the energy from the battery is used for starting the engine and/or lighting and/or other vehicle auxiliaries' systems over an appropriate driving cycle, e.g. WLTC for M1 and N1.]

The REESS may include ~~subsystem(s) together with the necessary ancillary~~ systems for physical support, thermal management, electronic control and enclosures."

Insert new Paragraphs 2.38., to read:

- "2.38. "**REESS subsystem**" means any assembly of REESS components which stores energy. A REESS subsystem may or may not include entire management system of the REESS."

Renumber (former) Paragraphs 2.30. to 2.31. as Paragraphs 2.39. to 2.40.

Renumber (former) Paragraph 2.33. as Paragraph 2.41., and amend to read:

- "2.41. "Solid insulator" means the insulating coating of wiring harnesses provided in order to cover and **prevent the high voltage** ~~protect the~~ live parts **from any** ~~against direct contact from any direction of access; covers for insulating the live parts of connectors, and varnish or paint for the purpose of insulation."~~

Insert new Paragraph 2.42., to read:

- "2.42. "**Specific voltage condition**" means the condition that the maximum voltage of a galvanically connected electrical circuit between a DC live

part and any other live part (DC or AC) is ≤ 30 V AC (rms) and ≤ 60 V DC.

Note: When a DC live part of such an electrical circuit is connected to chassis and the specific voltage condition applies, the maximum voltage between any live part and the electrical chassis is ≤ 30 V AC (rms) and ≤ 60 V DC."

Renumber (former) Paragraph 2.32. as Paragraph 2.43.

Remove (former) Paragraph 2.34.

Renumber (former) Paragraph 2.35. as Paragraph 2.44., and amend to read:

"2.44. ~~"Tested device~~Tested-Device" means either ~~the~~ complete REESS or ~~the~~ REESS subsystem of a REESS that is subjected to the tests prescribed by this Regulation."

Insert new Paragraphs 2.45. to 2.47., to read:

2.45. "Thermal event" means the condition when the temperature within the REESS is significantly higher (as defined by the manufacturer) than the maximum operating temperature.

2.46. "Thermal runaway" means an uncontrolled increase of cell temperature caused by exothermic reactions inside the cell.

2.47. "Thermal propagation" means the sequential occurrence of thermal runaway within a REESS triggered by thermal runaway of a cell in that REESS."

Renumber (former) Paragraph 2.36. as Paragraph 2.48.

Insert new Paragraphs 2.49 to 2.50., to read:

2.49. "Vehicle connector" means the device which is inserted into the vehicle inlet to supply electric energy to the vehicle from an external electric power supply.

2.50. "Vehicle inlet" means the device on the externally chargeable vehicle into which the vehicle connector is inserted for the purpose of transferring electric energy from an external electric power supply."

Renumber (former) Paragraph 2.37. as Paragraph 2.51.

Insert new Paragraph 2.52., to read:

"2.52. "Venting" means the release of excessive internal pressure from cell or REESS subsystem or REESS in a manner intended by design to preclude rupture or explosion."

Renumber (former) Paragraph 2.38. as Paragraph 2.53.

Remove (former) Paragraph 2.39.

Paragraph 3.1., amend to read:

"3.1. Part I: Approval of a vehicle type with regard to specific requirements for the electric power train its electrical safety, including the High Voltage System"

Paragraph 3.1.2.1., amend to read:

"3.1.2.1. Detailed description of the vehicle type ~~as with regards to~~ the electric power train and the ~~galvanically connected~~ high voltage bus **galvanically connected to it.**"

Paragraph 3.2.1., amend to read:

"3.2.1. The application for approval of a type of REESS ~~or separate technical unit~~ with regard to the safety requirements of the REESS shall be submitted by the REESS manufacturer or by his duly accredited representative."

Paragraph 3.2.2.1., amend to read:

"3.2.2.1. Detailed description of the type of REESS ~~or separate technical unit~~ as regards the safety of the REESS. "

Paragraph 4.2., amend to read:

"4.2. An approval number shall be assigned to each type approved **in accordance with Schedule 4 of the Agreement (E/ECE/TRANS/505/Rev.3)**. ~~Its first two digits (at present 02 for the Regulation in its form) shall indicate the series of amendments incorporating the most recent major technical amendments made to the Regulation at the time of issue of the approval. The same Contracting Party shall not assign the same number to another vehicle type.~~ "

Paragraph 4.4., amend to read:

"4.4. There shall be affixed, conspicuously and in a readily accessible place specified on the approval form, to every vehicle or REESS ~~or separate technical unit~~ conforming to a type approved under this Regulation an international approval mark consisting of: "

Paragraph 4.4.3., amend to read:

"4.4.3. In the case of an approval of a REESS ~~or a separate technical unit of the REESS~~ the "R" shall be followed by the symbol "ES". "

Paragraph 4.6.2., amend to read:

"4.6.2. In the case of a REESS ~~or separate technical unit approved as a REESS~~, the approval mark shall be affixed on the major element of the REESS by the manufacturer."

Paragraphs 5. to 5.1.1.4.2., amend to read:

"5. Part I: Requirements of a vehicle with regard to specific requirements for the electric power train ~~its electrical safety~~

5.1. Protection against electrical shock

These electrical safety requirements apply to high voltage buses **of electric power train and electrical components which are galvanically connected to the high voltage bus of electric power train** under conditions where they are not connected to external high voltage power supplies.

5.1.1. Protection against direct contact

~~Protection against direct contact with live parts is also required for vehicles equipped with any REESS type approved under Part II of this Regulation.~~

Live parts shall comply with paragraphs 5.1.1.1. and 5.1.1.2. **for protection against direct contact. Electrical protection B** barriers, enclosures, solid

insulators and connectors shall not be able to be opened, separated, disassembled or removed without the use of tools **or, for vehicles of categories N2, N3, M2 and M3, an operator controlled activation/deactivation device or equivalent.**

However, connectors (including the vehicle inlet) are allowed to be separated without the use of tools, if they meet one or more of the following requirements:

- (a) They comply with paragraphs 5.1.1.1. and 5.1.1.2. when separated, or
- ~~(b) They are located underneath the floor and are provided with a locking mechanism, or~~
- (eb) They are provided with a locking mechanism (at least two distinct actions are needed to separate the connector from its mating component). Additionally, other components, not being part of the connector, shall be removable only with the use of tools or, for vehicles of categories N2, N3, M2 and M3, an operator controlled activation/deactivation device or equivalent in order to be able to separate the connector, or**
- ~~(bc) The voltage of the live parts becomes equal or below 60 V DC or equal or below 30 V AC (rms) within 1 s after the connector is separated.~~

For vehicles of categories N2, N3, M2 and M3, conductive connection devices not energized except during charging of the REESS are exempted from this requirement if located on the roof of the vehicle out of reach for a person standing outside of the vehicle and, for vehicles of category M2 and M3, the minimum wrap around distance from the instep of the vehicle to the roof mounted charging devices is 3.00 m. In case of multiple steps due to elevated floor inside the vehicle, the wrap around distance is measured from the bottom most step at entry, as illustrated in Figure 1.

Figure 1
Schematics of how to measure wrap-around distance

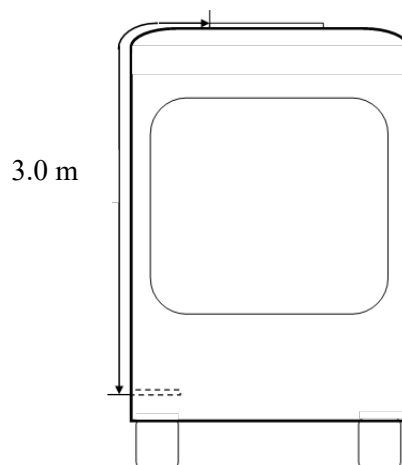

5.1.1.1. For ~~protection of~~ **high voltage** live parts inside the passenger compartment or luggage compartment, the protection degree IPXXD shall be provided.

5.1.1.2. For ~~protection of~~ **high voltage** live parts in areas other than the passenger compartment or luggage compartment, the protection degree IPXXB shall be **provided**~~satisfied~~.

5.1.1.3. Service disconnect

For a **high voltage** service disconnect which can be opened, disassembled or removed without tools, **or for vehicles of categories N2, N3, M2 and M3, an operator controlled activation/deactivation device or equivalent, it is acceptable if** protection degree IPXXB ~~is~~ **shall be** satisfied ~~under a condition where~~ **when** it is opened, disassembled or removed. ~~without tools.~~

5.1.1.4. Marking

5.1.1.4.1. ~~In the case of a REESS having high voltage capability~~ The symbol shown in Figure 4-2 shall ~~be present~~ **appear** on or near the REESS **having high voltage capability**. The symbol background shall be yellow, the bordering and the arrow shall be black.

This requirement shall also apply to a REESS which is part of a galvanically connected electrical circuit where the specific voltage condition is not fulfilled, independent of the maximum voltage of the REESS.

**Figure 4-2
Marking of high voltage equipment**

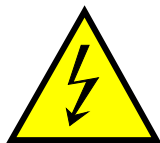

5.1.1.4.2. The symbol shall also be visible on enclosures and **electrical protection** barriers, which, when removed, expose live parts of high voltage circuits. This provision is optional to any connector for high voltage buses. This provision shall not apply to any of the following cases:

- (a) Where **electrical protection** barriers or enclosures cannot be physically accessed, opened, or removed; unless other vehicle components are removed with the use of tools;
- (b) Where **electrical protection** barriers or enclosures are located underneath the vehicle floor.
- (c) **Electrical protection barriers or enclosures of conductive connection device for vehicles of categories N2, N3, M2 and M3 which satisfies the conditions prescribed in Paragraph 5.1.1."**

Paragraphs 5.1.2. to 5.1.3., amend to read:

"5.1.2. Protection against indirect contact

~~Protection against indirect contact is also required for vehicles equipped with any REESS type approved under Part II of this Regulation.~~

5.1.2.1. For protection against electrical shock which could arise from indirect contact, the exposed conductive parts, such as the conductive **electrical protection** barrier and enclosure, shall be galvanically connected securely to the electrical

chassis by connection with electrical wire or ground cable, or by welding, or by connection using bolts, etc. so that no dangerous potentials are produced.

- 5.1.2.2. The resistance between all exposed conductive parts and the electrical chassis shall be lower than 0.1 ohm when there is current flow of at least 0.2 amperes.

The resistance between any two simultaneously reachable exposed conductive parts of the electrical protection barriers that are less than 2.5 m from each other shall not exceed 0.2 Ω. This resistance may be calculated using the separately measured resistances of the relevant parts of electric path.

This requirement is satisfied if the galvanic connection has been established by welding. **In case of doubts or the connection is established by other means than welding, a measurement shall be made by using one of the test procedures described in Annex 4.**

- 5.1.2.3. In the case of motor vehicles which are intended to be connected to the grounded external electric power supply through the conductive connection **between vehicle inlet and vehicle connector**, a device to enable the galvanical connection of the electrical chassis to the earth ground **for the external electric power supply** shall be provided.

The device should enable connection to the earth ground before exterior voltage is applied to the vehicle and retain the connection until after the exterior voltage is removed from the vehicle.

Compliance to this requirement may be demonstrated either by using the connector specified by the ~~car~~ vehicle manufacturer, **by visual inspection or drawings** ~~or by analysis.~~

The above requirements are only applicable for vehicles when charging from a stationary charging point, with a charging cable of finite length, through a vehicle coupler comprising a vehicle connector and a vehicle inlet.

- 5.1.3. Isolation resistance

This paragraph shall not apply to ~~chassis-connected~~ electrical circuits **that are galvanically connected to each other**, where **the DC part of these circuits is connected to the electrical chassis and the specific voltage condition is fulfilled**. ~~the maximum voltage between any live part and the electrical chassis or any exposed conductive part does not exceed 30V AC (rms) or 60 V DC."~~

Paragraphs 5.1.3.2. to 5.1.3.4., amend to read:

- "5.1.3.2. Electric power train consisting of combined DC- and AC-buses

If AC high voltage buses and DC high voltage buses are galvanically connected, isolation resistance between the high voltage bus and the electrical chassis shall have a minimum value of 500 Ω/volt of the working voltage.

However, if all AC high voltage buses are protected by one of the ~~2~~ **two** following measures, isolation resistance between the high voltage bus and the electrical chassis shall have a minimum value of 100 Ω/V of the working voltage:

- (a) **At least two** ~~Double~~ or more layers of solid insulators, **electrical protection** barriers or enclosures that meet the requirement in paragraph 5.1.1. independently, for example wiring harness;

- (b) Mechanically robust protections that have sufficient durability over vehicle service life such as motor housings, electronic converter cases or connectors;

The isolation resistance between the high voltage bus and the electrical chassis may be demonstrated by calculation, measurement or a combination of both.

The measurement shall be conducted according to Annex 5A4A "Isolation resistance measurement method for vehicle based tests".

5.1.3.3. Fuel cell vehicles

In fuel cell vehicles, DC high voltage buses shall have an on-board isolation resistance monitoring system together with a warning to the driver if the isolation resistance drops below the minimum required value of 100 Ω/V. The function of the on-board isolation resistance monitoring system shall be confirmed as described in Annex 6.

The isolation resistance between the high voltage bus of the coupling system for charging the REESS, which is not energized in conditions other than that during the charging of the REESS, and the electrical chassis need not to be monitored.

~~If the minimum isolation resistance requirement cannot be maintained over time, then protection shall be achieved by any of the following:~~

- ~~(a) Double or more layers of solid insulators, barriers or enclosures that meet the requirement in paragraph 5.1.1. independently;~~
- ~~(b) On board isolation resistance monitoring system together with a warning to the driver if the isolation resistance drops below the minimum required value. The isolation resistance between the high voltage bus of the coupling system for charging the REESS, which is not energized besides during charging the REESS, and the electrical chassis need not be monitored. The function of the on board isolation resistance monitoring system shall be confirmed as described in Annex 5.~~

5.1.3.4. Isolation resistance requirement for the coupling system for charging the REESS

For the vehicle **conductive connection device** ~~inlet~~ intended to be conductively connected to the grounded external AC power supply and the electrical circuit that is galvanically connected to the vehicle **conductive connection device** ~~inlet~~ during charging of the REESS, the isolation resistance between the high voltage bus and the electrical chassis shall **comply with the requirements of paragraph 5.1.3.1. when the conductive connection is disconnected and the isolation resistance is measured at the high voltage live parts (contacts) of the vehicle conductive connection device.** ~~be at least 1 MΩ when the charger coupler is disconnected. During the measurement, the traction battery REESS may be disconnected.~~

Insert new Paragraphs 5.1.4. to 5.1.4.4., to read:

5.1.4. Protection against water effects.

The vehicles shall maintain isolation resistance after exposure to water (e.g. washing, driving through standing water). This paragraph shall not apply to electrical circuits that are galvanically connected to each other, where the DC part of these circuits is connected to the electrical chassis and the specific voltage condition is fulfilled.

- 5.1.4.1. The vehicle manufacturer can choose to comply with requirements specified in paragraph 5.1.4.2., those specified in paragraph 5.1.4.3., or those specified in paragraph 5.1.4.4.
- 5.1.4.2. The vehicle manufacturers shall provide evidence and/or documentation to the regulatory or testing entity as applicable on how the electrical design or the components of the vehicle located outside the passenger compartment or externally attached, after water exposure remain safe and comply with the requirements described in Annex 7A. If the evidence and/or documentation provided is not satisfactory the regulatory or testing entity as applicable shall require the manufacturer to perform a physical component test based on the same specifications as those described in Annex 7A.
- 5.1.4.3. If the test procedures specified in Annex 7B are performed, just after each exposure, and with the vehicle still wet, the vehicle shall then comply with isolation resistance test given in Annex 5A, and the isolation resistance requirements given in paragraph 5.1.3. shall be met. In addition, after a 24 hour pause, the isolation resistance test specified in Annex 5A shall again be performed, and the isolation resistance requirements given in paragraph 5.1.3. shall be met.
- 5.1.4.4. If an isolation resistance monitoring system is provided, and the isolation resistance less than the requirements given in paragraph 5.1.3. is detected, a warning shall be indicated to the driver. The function of the on-board isolation resistance monitoring system shall be confirmed as described in Annex 6."

Paragraphs 5.2.1.1. to 5.2.1.2., amend to read:

- "5.2.1.1. For a REESS which has been type approved in accordance with Part II of this **series of Amendment to this** Regulation, it shall be installed in accordance with the instructions provided by the manufacturer of the REESS, and in conformity with the description provided in ~~Part 2 of Annex 6-1, Appendix 2~~ to this Regulation.
- 5.2.1.2. The REESS **including related vehicle components, systems and structure as applicable**, shall comply with the respective requirements of paragraph 6. of this Regulation. "

Insert new paragraphs 5.2.3. to 5.2.4., to read:

- "5.2.3. **Warning in the event of failure in REESS**

The vehicle shall provide a warning to the driver when the vehicle is in active driving possible mode in the event specified in paragraphs 6.13. to 6.15.

In case of optical warning, the tell-tale shall, when illuminated, be sufficiently bright to be visible to the driver under both daylight and night-time driving conditions, when the driver has adapted to the ambient roadway light conditions.

This tell-tale shall be activated as a check of lamp function either when the propulsion system is turned to the "On" position, or when the propulsion system is in a position between "On" and "Start" that is designated by the manufacturer as a check position. This requirement does not apply to the tell-tale or text shown in a common space.
- 5.2.4. **Warning in the event of low energy content of REESS.**

For pure electric vehicles (vehicles equipped with a powertrain containing exclusively electric machines as propulsion energy converters and exclusively rechargeable electric energy storage systems as propulsion energy storage systems), a warning to the driver in the event of low REESS state of charge shall be provided. Based on engineering judgment, the manufacturer shall determine the necessary level of REESS energy remaining, when the driver warning is first provided.

In case of optical warning, the tell-tale shall, when illuminated, be sufficiently bright to be visible to the driver under both daylight and night-time driving conditions, when the driver has adapted to the ambient roadway light conditions. "

Paragraph 5.3., amend to read:

"5.3. **Preventing accidental or unintended vehicle movement** ~~Functional safety~~

5.3.1. At least a momentary indication shall be given to the driver **each time** when the vehicle is **first placed** in "active driving possible mode" **after manual activation of the propulsion system.**

However, this provision ~~does not apply~~ **is optional** under conditions where an internal combustion engine provides directly or indirectly the vehicle's propulsion power **upon start up.**

5.3.2. When leaving the vehicle, the driver shall be informed by a signal (e.g. optical or audible signal) if the vehicle is still in the active driving possible mode. **Moreover, in case of vehicles of category M2 and M3 with a capacity of more than 22 passengers in addition to the driver, this signal shall already be given when the drivers leave their seat.**

However, this provision is optional under conditions where an internal combustion engine provides directly or indirectly the vehicle's propulsion power while leaving the vehicle or driver seat.

5.3.3. If the ~~on-board~~ REESS can be externally charged ~~by the user~~, vehicle movement by its own propulsion system shall be impossible as long as the **vehicle** connector of the external electric power supply is physically connected to the vehicle inlet.

This requirement shall be demonstrated by using the **vehicle** connector specified by the ~~car~~ **vehicle** manufacturer.

The above requirements are only applicable for vehicles when charging from a stationary charging point, with a charging cable of finite length, through a vehicle coupler comprising a vehicle connector and a vehicle inlet.

5.3.4. The state of the drive direction control unit shall be identified to the driver."

Paragraphs 5.4.1. to 5.4.4., amend to read:

"5.4.1. This test ... paragraph 5.2.1.1., this test can be ...

5.4.2. The test ... in Annex ~~78~~ **to the present this** Regulation. ...

5.4.3. During ... in Annex ~~78~~, hydrogen

5.4.4. During ...a failure (conditions given in Annex ~~78~~), hydrogen ... "

Paragraph 5.4.10., amend to read:

"5.4.10. This approval ... given in Annex ~~78~~, Appendix 2.

Paragraph 6.1., amend to read:

"6.1. General

The procedures ... in Annex ~~98~~ of ...

Paragraph 6.2.1., amend to read:

"6.2.1. This test ... with Annex ~~9A-8A~~ to this Regulation. "

Paragraphs 6.2.2.1. to 6.2.2.2., amend to read:

"6.2.2.1. During the test, there shall be no evidence of:

- (a) Electrolyte leakage;
- (b) Rupture (applicable to high voltage REESS (s) only);
- (c) **Venting (for REESS other than open-type traction battery)**
- (d) Fire;
- (~~e~~) Explosion.

~~The e~~Evidence of electrolyte leakage shall be verified by visual inspection without disassembling any part of the ~~tested device~~**Tested-Device**. **An appropriate technique shall, if necessary, be used in order to confirm if there is any electrolyte leakage from the REESS resulting from the test. The evidence of venting shall be verified by visual inspection without disassembling any part of the Tested-Device.**

6.2.2.2. For a high voltage REESS, the isolation resistance measured after the test in accordance with Annex ~~5B-4B~~ to this Regulation shall not be less than 100 Ω /Volt. "

Paragraph 6.3.1., amend to read:

"6.3.1. This test ... with Annex ~~9B-8B~~ to this Regulation. "

Paragraphs 6.3.2.1. to 6.3.2.2., amend to read:

"6.3.2.1. During the test, there shall be no evidence of:

- (a) Electrolyte leakage;
- (b) Rupture (applicable to high voltage REESS (s) only);
- (c) **Venting (for REESS other than open-type traction battery)**
- (d) Fire;
- (~~e~~) Explosion.

~~The e~~Evidence of electrolyte leakage shall be verified by visual inspection without disassembling any part of the ~~tested device~~**Tested-Device**. **An appropriate technique shall, if necessary, be used in order to confirm if there is any electrolyte leakage from the REESS resulting from the test. The evidence of venting shall be verified by visual inspection without disassembling any part of the Tested-Device.**

6.3.2.2. For a high voltage REESS, the isolation resistance measured after the test in accordance with Annex ~~5B-4B~~ to this Regulation shall not be less than 100 Ω /Volt. "

Paragraphs 6.4.1.1 to 6.4.1.3., amend to read:

"6.4.1.1. Vehicle based test

Compliance with the requirements of the acceptance criteria of paragraph 6.4.1.3. below may be demonstrated by REESS(s) installed in vehicles that have been subjected to vehicle crash tests in accordance with ~~Regulation No. 12, Annex 3~~ or Regulation No. 94, Annex 3 **or Regulation No.137, Annex 3** for frontal impact, and Regulation No. 95, Annex 4 for side impact. The ambient temperature and the SOC shall be in accordance with the said Regulations. **This requirement is deemed to be met if the vehicle equipped with electric power train operating on high voltage is approved in accordance with Regulation No. 94 ([04] series of amendments or later) or Regulation No.137 ([01] series of amendments or later) for frontal impact and Regulation No.95 ([05] series of amendments or later) for lateral impact.**

The approval of a REESS tested under this paragraph shall be limited to the specific vehicle type. "

6.4.1.2. Component based test

The test ... Annex ~~9C&C~~ to this Regulation.

6.4.1.3. Acceptance criteria

During the test there shall be no evidence of:

- (a) Fire;
- (b) Explosion;
- (c1) Electrolyte leakage if tested according to paragraph 6.4.1.1.:

(i) **In case of aqueous electrolyte REESS:**

For a period from the impact until ~~30~~**60** minutes after the impact, there shall be no electrolyte ~~spillage~~**leakage** from the REESS into the passenger compartment **and;**

~~(ii) n~~**No more than 7 per cent by volume of the REESS electrolyte with a maximum of 5.0 l leaked capacity shall spill from the REESS to the outside of the passenger compartment (for open type traction batteries a limitation to a maximum of 5 litres also applies). The leaked amount of electrolyte can be measured by usual techniques of determination of liquid volumes after its collection. For containers containing Stoddard, coloured coolant and electrolyte, the fluids shall be allowed to separate by specific gravity then measured;**

(ii) **In case of non-aqueous electrolyte REESS:**

For a period from the impact until 60 minutes after the impact, there shall be no liquid electrolyte leakage from the REESS into the passenger compartment, luggage compartment and no liquid electrolyte leakage to outside the vehicle. This requirement shall be verified by visual inspection without disassembling any part of the vehicle.

- (c2) Electrolyte leakage if tested according to paragraph 6.4.1.2.

After the vehicle based test (paragraph 6.4.1.1.), ~~a~~ **REESS shall remain attached to the vehicle by at least one component anchorage, bracket, or any structure that transfers loads from REESS to the vehicle structure, and REESS located outside the passenger compartment shall not enter the passenger compartment** ~~which is located inside the passenger compartment shall remain in the installed location and the REESS components shall remain inside REESS boundaries. No part of any REESS that is located outside the passenger compartment shall enter the passenger compartment during or after the impact test procedures.~~

After the component based test (paragraph 6.4.1.2.) the ~~tested device~~ **Tested-Device** shall be retained by its mounting and its components shall remain inside its boundaries.

For a high voltage REESS the isolation resistance of the ~~tested device~~ **Tested-Device** shall ensure at least 100 Ω/Volt for the whole REESS measured after the test in accordance with Annex ~~45A~~ or Annex ~~45B~~ to this Regulation, or the protection degree IPXXB shall be fulfilled for the ~~tested device~~ **Tested-Device**.

For a REESS tested in accordance with paragraph 6.4.1.2., the evidence of electrolyte leakage shall be verified by visual inspection without disassembling any part of the ~~tested device~~ **Tested-Device**.

~~To confirm compliance to (c1) of paragraph 6.4.1.3. an appropriate coating shall, if necessary, be applied to the physical protection (casing) in order to confirm if there is any electrolyte leakage from the REESS resulting from the impact test. Unless the manufacturer provides a means to differentiate between the leakage of different liquids, all liquid leakage shall be considered as the electrolyte. "~~

Paragraphs 6.4.2.1.1 to 6.4.2.3., amend to read:

"6.4.2.1.1. Vehicle based dynamic test

Compliance with ... in accordance with the Annex 3 to Regulations Nos. ~~12, or 94 or 137~~ for frontal impact, and ... with the said Regulations. **This requirement is deemed to be met if the vehicle equipped with electric power train operating on high voltage is approved in accordance with Regulation No. 94 ([04] series of amendments or later) or Regulation No.137 ([01] series of amendments or later) for frontal impact and Regulation No.95 ([05] series of amendments or later) for lateral impact.**

6.4.2.1.2. Vehicle specific component test

The test ... with Annex ~~89D~~ of this Regulation.

The crush force ~~replacing the prescribed force~~ specified in paragraph 3.2.1. of Annex ~~89D~~ **may be replaced with the value declared** ~~shall be determined~~ by the vehicle manufacturer using the data obtained from either actual crash tests or its simulation as specified in Annex 3 of Regulations ~~No. 12, or~~ Nos. ~~94 or 137~~ in the direction of travel and according to Annex 4 to Regulation No. 95 in the direction ...

6.4.2.2. Component based test

The test ... with Annex ~~89D~~ to this Regulation. ...

The mounting ... documented in Annex ~~6-1 - Part~~ **Appendix 2**.

The crush force specified in paragraph 3.2.1. of Annex 89D may be ... documented in Annex 61, Part-Appendix 2 as a mounting ...in Annex 3 of Regulations Nos. 12, or 94 or 137 in the direction ...

6.4.2.3. Acceptance criteria

During the test there shall be no evidence of:

- (a) Fire;
- (b) Explosion;
- (c1) Electrolyte leakage if tested according to paragraph 6.4.1.1.:

(i) **In case of aqueous electrolyte REESS:**

For a period from the impact until ~~30~~**60** minutes after the impact there shall be no electrolyte ~~spillage~~**leakage** from the REESS into the passenger compartment **and**-

~~(ii) — No more than 7 per cent by volume of the REESS electrolyte with a maximum of 5.0 l leaked capacity shall spill from the REESS to the outside of the passenger compartment. The leaked amount of electrolyte can be measured by usual techniques of determination of liquid volumes after its collection. For containers containing Stoddard, coloured coolant and electrolyte, the fluids shall be allowed to separate by specific gravity then measured (for open type traction batteries a limitation to a maximum of 5 litres also applies).~~

(ii) **In case of non-aqueous electrolyte REESS:**

For a period from the impact until 60 minutes after the impact, there shall be no liquid electrolyte leakage from the REESS into the passenger compartment, luggage compartment and no liquid electrolyte leakage to outside the vehicle. This requirement shall be verified by visual inspection without disassembling any part of the vehicle.

- (c2) Electrolyte leakage if tested according to paragraph 6.4.2.2.

For a high voltage REESS, the isolation resistance of the ~~tested device~~**Tested-Device** shall ensure at least 100 Ω/Volt for the whole REESS measured in accordance with Annex 45A or Annex 45B of this Regulation or the protection degree IPXXB shall be fulfilled for the Tested-Device.

If tested according to paragraph 6.4.2.2., the evidence of electrolyte leakage shall be verified by visual inspection without disassembling any part of the ~~tested device~~**Tested-Device**.

~~To confirm compliance to (c1) of paragraph 6.4.2.3. an appropriate coating shall, if necessary, be applied to the physical protection (casing) in order to confirm if there is any electrolyte leakage from the REESS resulting from the impact test. Unless the manufacturer provides a means to differentiate between the leakage of different liquids, all liquid leakage shall be considered as the electrolyte."~~

Paragraphs 6.5.1. to 6.5.2., amend to read:

"6.5.1. Vehicle based test
The test ... with Annex 89E paragraph 3.2.1. of this Regulation.
...

6.5.2. Component based test
The test ... with Annex 89E paragraph 3.2.2. of this Regulation. "

Paragraph 6.6.1., amend to read:

"6.6.1. The test ... with Annex 89F of this Regulation. "

Paragraphs 6.6.2.1. to 6.6.2.2., amend to read:

"6.6.2.1. During the test there shall be no evidence of:

- (a) Electrolyte leakage;
- (b) Rupture (applicable to high voltage REESS(s) only);
- (c) **Venting (for REESS other than open-type traction battery);**
- (d) Fire;
- (~~e~~) Explosion.

The evidence of electrolyte leakage shall be verified by visual inspection without disassembling any part of the ~~tested device~~ Tested-Device. An appropriate technique shall, if necessary, be used in order to confirm if there is any electrolyte leakage from the REESS resulting from the test. The evidence of venting shall be verified by visual inspection without disassembling any part of the Tested-Device.

6.6.2.2. For a high voltage ... with Annex 4B5B to this Regulation shall not ..."

Paragraph 6.7.1., amend to read:

"6.7.1. The test ... with Annex 89G of this Regulation. "

Paragraphs 6.7.2.1. to 6.7.2.2., amend to read:

"6.7.2.1. During the test there shall be no evidence of:

- (a) Electrolyte leakage;
- (b) Rupture (applicable to high voltage REESS(s) only);
- (c) **Venting (for REESS other than open-type traction battery);**
- (d) Fire;
- (~~e~~) Explosion.

The evidence of electrolyte leakage shall be verified by visual inspection without disassembling any part of the ~~tested device~~ Tested-Device. An appropriate technique shall, if necessary, be used in order to confirm if there is any electrolyte leakage from the REESS resulting from the test. The evidence of venting shall be verified by visual inspection without disassembling any part of the Tested-Device.

6.7.2.2. For a high voltage ... with Annex 4B5B to this Regulation shall not ..."

Paragraph 6.8.1., amend to read:

"6.8.1. The test ... with Annex ~~89~~H of this Regulation. "

Paragraphs 6.8.2.1. to 6.8.2.2., amend to read:

"6.8.2.1. During the test there shall be no evidence of:

- (a) Electrolyte leakage;
- (b) Rupture (applicable to high voltage REESS(s) only);
- (c) **Venting (for REESS other than open-type traction battery);**
- (d) Fire;
- (~~e~~) Explosion.

The evidence of electrolyte leakage shall be verified by visual inspection without disassembling any part of the ~~tested device~~ Tested-Device. An appropriate technique shall, if necessary, be used in order to confirm if there is any electrolyte leakage from the REESS resulting from the test. The evidence of venting shall be verified by visual inspection without disassembling any part of the Tested-Device.

6.8.2.2. For a high voltage ... with Annex ~~4B~~5B to this Regulation shall not ..."

Paragraph 6.9.1., amend to read:

"6.9.1. The test ... with Annex ~~89~~I of this Regulation. "

Paragraphs 6.9.2.1. to 6.9.2.2., amend to read:

"6.9.2.1. During the test there shall be no evidence of:

- (a) Electrolyte leakage;
- (b) Rupture (applicable to high voltage REESS(s) only);
- (c) **Venting (for REESS other than open-type traction battery);**
- (d) Fire;
- (~~e~~) Explosion.

The evidence of electrolyte leakage shall be verified by visual inspection without disassembling any part of the ~~tested device~~ Tested-Device. An appropriate technique shall, if necessary, be used in order to confirm if there is any electrolyte leakage from the REESS resulting from the test. The evidence of venting shall be verified by visual inspection without disassembling any part of the Tested-Device.

6.9.2.2. For a high voltage ... with Annex ~~4B~~5B to this Regulation shall not ..."

Remove (former) Paragraphs 6.10. to 6.10.2.

Insert new Paragraphs 6.10. to 6.15.2.4.3., to read:

6.10. Overcurrent protection

This test is required for REESS intended for use on vehicles of categories M1 and N1 that have the capability of charging by DC external electricity supply.

6.10.1. The test shall be conducted in accordance with Annex 9J to this Regulation.

6.10.2. Acceptance criteria

6.10.2.1. During the test there shall be no evidence of:

- (a) Electrolyte leakage;**
- (b) Rupture (applicable to high voltage REESS(s) only);**
- (c) Venting (for REESS other than open-type traction battery)**
- (d) Fire;**
- (e) Explosion.**

The evidence of electrolyte leakage shall be verified by visual inspection without disassembling any part of the Tested-Device. An appropriate technique shall, if necessary, be used in order to confirm if there is any electrolyte leakage from the REESS resulting from the test. The evidence of venting shall be verified by visual inspection without disassembling any part of the Tested-Device.

6.10.2.2. The overcurrent protection control of the REESS shall terminate charging or the temperature measured on the casing of the REESS shall be stabilized, such that the temperature gradient varies by less than 4 °C through 2 hours after the maximum overcurrent charging level is reached.

6.10.2.3. For a high voltage REESS, the isolation resistance measured after the test in accordance with Annex 5B to this Regulation shall not be less than 100 Ω/V.

6.11. Low-temperature protection.

REESS manufacturer must make available, at the request of the Technical Service with its necessity, the following documentations explaining safety performance of the system level or sub-system level of the vehicle to demonstrate that the REESS monitors and appropriately controls REESS operations at low temperatures at the safety boundary limits of the REESS:

- (a) A system diagram;**
- (b) Written explanation on the lower boundary temperature for safe operation of REESS;**
- (c) Method of detecting REESS temperature;**
- (d) Action taken when the REESS temperature is at or lower than the lower boundary for safe operation of the REESS.**

6.12. Management of gases emitted from REESS

6.12.1. Under vehicle operation including the operation with a failure, the vehicle occupants shall not be exposed to any hazardous environment caused by emissions from REESS.

6.12.2. Open-type traction batteries shall meet the requirements of paragraph 5.4. of this Regulation with regard to hydrogen emissions.

6.12.3. For REESS other than open-type traction battery, the requirement of paragraph 6.12.1. is deemed to be satisfied, if all applicable requirements of the following tests are met: paragraph 6.2. (vibration), paragraph 6.3. (thermal shock and cycling), paragraph 6.6. (external short circuit protection), paragraph 6.7. (overcharge protection), paragraph 6.8. (over-discharge protection), paragraph 6.9. (over-temperature protection) and paragraph 6.10. (overcurrent protection).

6.13. Warning in the event of operational failure of vehicle controls that manage REESS safe operation.

The REESS or vehicle system shall provide a signal to activate the warning specified in paragraph 5.2.3. in the event of operational failure of the vehicle controls (e.g. input and output signals to the management system of REESS, sensors within REESS, etc.) that manage the safe operation of the REESS. REESS or vehicle manufacturer shall make available, at the request of the Technical Service with its necessity, the following documentation explaining safety performance of the system level or sub-system level of the vehicle:

6.13.1. A system diagram that identifies all the vehicle controls that manage REESS operations. The diagram must identify what components are used to generate a warning due to operational failure of vehicle controls to conduct one or more basic operations.

6.13.2. A written explanation describing the basic operation of the vehicle controls that manage REESS operation. The explanation must identify the components of the vehicle control system, provide description of their functions and capability to manage the REESS, and provide a logic diagram and description of conditions that would lead to triggering of the warning.

6.14. Warning in the case of a thermal event within the REESS.

The REESS or vehicle system shall provide a signal to activate the warning specified in paragraph 5.2.3. in the case of a thermal event in the REESS (as specified by the manufacturer). REESS or vehicle manufacturer shall make available, at the request of the Technical Service with its necessity, the following documentation explaining safety performance of the system level or sub-system level of the vehicle:

6.14.1. The parameters and associated threshold levels that are used to indicate a thermal event (e.g. temperature, temperature rise rate, SOC level, voltage drop, electrical current, etc.) to trigger the warning.

6.14.2. A system diagram and written explanation describing the sensors and operation of the vehicle controls to manage the REESS in the event of a thermal event.

6.15. Thermal propagation.

For a REESS containing flammable electrolyte, the vehicle occupants shall not be exposed to any hazardous environment caused by thermal propagation which is triggered by an internal short circuit leading to a single cell thermal runaway. To ensure this, the requirements of paragraphs 6.15.1. and 6.15.2. shall be satisfied.²

6.15.1. The REESS or vehicle system shall provide a signal to activate the advance warning indication in the vehicle to allow egress or 5 minutes prior to the presence of a hazardous situation inside the passenger compartment caused by thermal propagation which is triggered by an internal short circuit leading to a single cell thermal runaway such as fire, explosion or smoke. This requirement is deemed to be satisfied if the thermal

² The manufacturer will be accountable for the verity and integrity of documentation submitted, assuming full responsibility for the safety of occupants against adverse effects arising from thermal propagation caused by internal short circuit.

propagation does not lead to a hazardous situation for the vehicle occupants. REESS or vehicle manufacturer shall make available, at the request of the Technical Service with its necessity, the following documentation explaining safety performance of the system level or sub-system level of the vehicle:

- 6.15.1.1. The parameters (for example, temperature, voltage or electrical current) which trigger the warning indication.
- 6.15.1.2. Description of the warning system.
- 6.15.2. The REESS or vehicle system shall have functions or characteristics in the cell or REESS intended to protect vehicle occupants (as described in paragraph 6.15.) in conditions caused by thermal propagation which is triggered by an internal short circuit leading to a single cell thermal runaway. REESS or vehicle manufacturers shall make available, at the request of the Technical Service with its necessity, the following documentation explaining safety performance of the system level or sub-system level of the vehicle:
 - 6.15.2.1. A risk reduction analysis using appropriate industry standard methodology (for example, IEC 61508, MIL-STD 882E, ISO 26262, AIAG DFMEA, fault analysis as in SAE J2929, or similar), which documents the risk to vehicle occupants caused by thermal propagation which is triggered by an internal short circuit leading to a single cell thermal runaway and documents the reduction of risk resulting from implementation of the identified risk mitigation functions or characteristics.
 - 6.15.2.2. A system diagram of all relevant physical systems and components. Relevant systems and components are those which contribute to protection of vehicle occupants from hazardous effects caused by thermal propagation triggered by a single cell thermal runaway.
 - 6.15.2.3. A diagram showing the functional operation of the relevant systems and components, identifying all risk mitigation functions or characteristics.
 - 6.15.2.4. For each identified risk mitigation function or characteristic:
 - 6.15.2.4.1. A description of its operation strategy;
 - 6.15.2.4.2. Identification of the physical system or component which implements the function;
 - 6.15.2.4.3. One or more of the following engineering documents relevant to the manufacturers design which demonstrates the effectiveness of the risk mitigation function:
 - (a) Tests performed including procedure used and conditions and resulting data;
 - (b) Analysis or validated simulation methodology and resulting data. "

Paragraphs 7. to 7.1.2., amend to read:

"7. Modifications and extension of the type approval

7.1. Every modification of the vehicle or REESS type with regard to this Regulation shall be notified to the Type Approval Authority which approved the vehicle or REESS type. The Authority may then either:

- (a) Decide, in consultation with the manufacturer, that a new type approval is to be granted; or
- (b) Apply the procedure contained in paragraph 7.1.1. (Revision) and, if applicable, the procedure contained in paragraph 7.1.2. (Extension).

7.1.1. Revision

When particulars recorded in the information documents of Annex 1 - Appendix 1 or Annex 1 - Appendix 2 have changed and the Type Approval Authority considers that the modifications made are unlikely to have appreciable adverse effect, and that in any case the vehicle still meets the requirements, the modification shall be designated a "revision".

In such a case, the Type Approval Authority shall issue the revised pages of the information documents of Annex 1 - Appendix 1 or Annex 1 - Appendix 2 as necessary, marking each revised page to show clearly the nature of the modification and the date of re-issue. A consolidated, updated version of the information documents of Annex 1 - Appendix 1 or Annex 1 - Appendix 2, accompanied by a detailed description of the modification, shall be deemed to meet this requirement. ~~Consider that the modifications made are unlikely to have an appreciable adverse effect and that in any case the vehicle or the REESS still complies with the requirements, or~~

7.1.2. Extension

The modification shall be designated an "extension" if, in addition to the change of the particulars recorded in the information folder:

- (a) Further inspections or tests are required; or
- (b) Any information on the communication document (with the exception of its attachments) has changed; or
- (c) Approval to a later series of amendments is requested after its entry into force. ~~Require a further test report from the Technical Service responsible for conducting the tests. "~~

Remove paragraphs 7.2. to 7.3.

Insert new hanging paragraph under paragraph 8., to read:

"8. Conformity of production

The conformity of production procedure shall comply with the requirements set out in Schedule 1 of the Agreement (E/ECE/TRANS/505/Rev.3). "

Remove paragraphs 8.3. to 8.4.5.

Paragraphs 9.1. to 9.2., amend to read:

- "9.1. The approval granted in respect of a vehicle/REESS type, pursuant to this Regulation may be withdrawn if the requirements laid down in paragraph 8. above are not complied with, ~~or if the vehicle/REESS or its components fail to pass the tests provided for in paragraph 8.3.5. above.~~
- 9.2. If a Contracting Party to the Agreement applying this Regulation withdraws an approval it has previously granted, it shall forthwith so notify the other Contracting Parties applying this Regulation, by means of **a copy of the approval form bearing at the end, in large letters, the signed and dated annotation "APPROVAL WITHDRAWN"**. ~~a communication form conforming to the Model in Annex 1 (Part 1 or Part 2) to this Regulation.~~ "

Paragraph 10., amend to read:

"10. Production definitively discontinued

If the holder of the approval completely ceases to manufacture a vehicle/REESS type approved in accordance with this Regulation, he shall so inform the **Type Approval** Authority which granted the approval. Upon receiving the relevant communication, that **Type Approval** Authority shall inform thereof the other Contracting Parties to the ~~1958~~-Agreement applying this Regulation by means of **a copy of the approval form bearing at the end, in large letters, the signed and dated annotation "PRODUCTION DISCONTINUED"**. ~~a communication form conforming to the model in Annex 1 (Part 1 or Part 2) to this Regulation.~~ "

Replace (former) paragraphs 12.1 to 12.5 with new paragraphs 12.1 to 12.4., to read:

- "12.1. **As from the official date of entry into force of the 03 series of amendments, no Contracting Party applying this Regulation shall refuse to grant or refuse to accept type approvals under this Regulation as amended by the 03 series of amendments.**
- 12.2. **As from 1 September [2023], Contracting Parties applying this Regulation shall not be obliged to accept type approvals to the preceding series of amendments, first issued after 1 September [2023].**
- 12.3. **Contracting Parties applying this Regulation shall not refuse to grant type approvals according to any preceding series of amendments to this Regulation or extensions thereof.**
- 12.4. **Notwithstanding the transitional provisions above, Contracting Parties who start to apply this Regulation after the date of entry into force of the most recent series of amendments are not obliged to accept type approvals which were granted in accordance with any of the preceding series of amendments to this Regulation.** "

Re-number (former) Annex 6 - Part 1 as Annex 1 – Appendix 1.

Re-number (former) Annex 6 - Part 2 as Annex 1 – Appendix 2.

Insert new item 1.1.1. to Annex 1 – Appendix 2, to read:

"1.1.1. **Type of REESS"**

Annex 3, Paragraphs 2. to 3., amend to read:

- "2. Test conditions
The access probe ...
Internal **electrical protection** barriers are ...
A low-voltage ... inside the **electrical protection** barrier or enclosure.
...
3. Acceptance conditions
The access probe ...
In ~~the~~ case of the test for **protection degree** IPXXB, the jointed ...
In case of the tests for **protection degree** IPXXD, the access probe ..."

Replace Annex 3, Figure 1, with;

"Figure 1
Jointed test finger

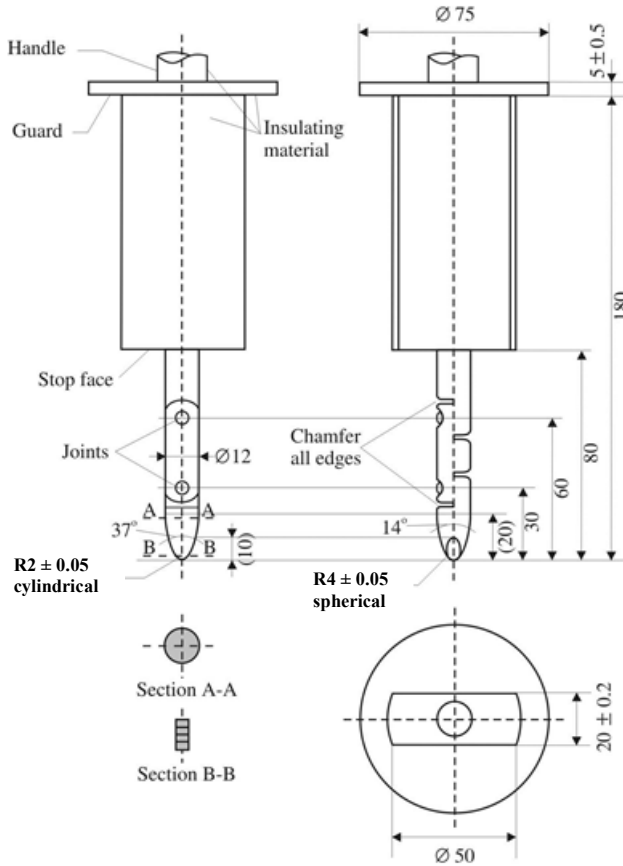

Material: metal, except where otherwise specified

Linear dimensions in millimeters

Tolerances on dimensions without specific tolerance:

- (a) ~~On~~ angles: 0/-10 **seconds**;
- (b) On linear dimensions:
 - (i) up to 25 mm: 0/-0.05 mm
 - (ii) over 25 mm: ±0.2 mm

Both joints shall permit movement in the same plane and the same direction through an angle of 90° with a 0 to +10° tolerance. "

Insert new Annex 4 (Verification of potential equalization), to read:

" Annex 4

Verification of potential equalization

1. Test method using a resistance tester.

The resistance tester is connected to the measuring points (typically, electrical chassis and electro conductive enclosure/electrical protection barrier) and the resistance is measured using a resistance tester that meets the specification that follows:

- (i) Resistance tester: Measurement current at least 0.2 A;
- (ii) Resolution: 0.01 Ω or less;
- (iii) The resistance R shall be less than 0.1 Ω .

2. Test method using DC power supply, voltmeter and ammeter.

Example of the test method using DC power supply, voltmeter and ammeter is shown below.

Figure 1

Example of test method using DC power supply

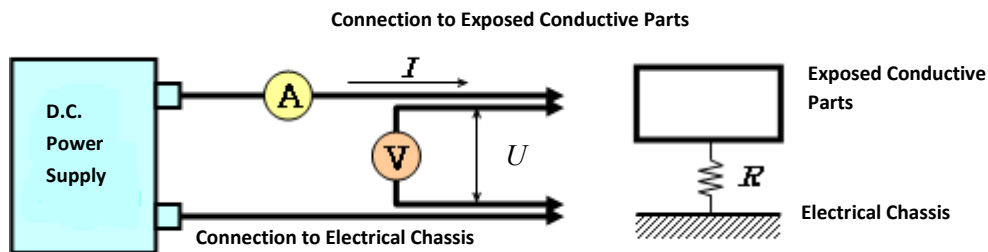

2.1. Test Procedure.

The DC power supply, voltmeter and ammeter are connected to the measuring points (Typically, electrical chassis and electro conductive enclosure/electrical protection barrier).

The voltage of the DC power supply is adjusted so that the current flow becomes at least 0.2 A.

The current "I" and the voltage "U" are measured.

The resistance "R" is calculated according to the following formula:

$$R = U / I$$

The resistance R shall be less than 0.1 Ω .

Note: If lead wires are used for voltage and current measurement, each lead wire shall be independently connected to the electrical protection barrier/enclosure/electrical chassis. Terminal can be common for voltage measurement and current measurement. "

Renumber (former) Annex 4A and Annex 4B as Annex 5A and Annex 5B.

Throughout new Annex 5A and Annex 5B (including Figures), replace the symbols for voltage, $V, V_b, V_1, V_1', V_2, V_2'$, with $U, U_b, U_1, U_1', U_2, U_2'$.

Annex 5A, paragraphs 2. to 2.1., Amend to read:

"2. Measurement method

The isolation resistance measurement shall be conducted by selecting an appropriate measurement method from among those listed in paragraphs 2.1. through 2.2. of this annex, depending on the electrical charge of the live parts or the isolation resistance, etc.

Megohmmeter or oscilloscope measurements are appropriate alternatives to the procedure described below for measuring isolation resistance. In this case, it may be necessary to deactivate the on-board isolation resistance monitoring system.

The range of the electrical circuit to be measured shall be clarified in advance, using electrical circuit diagrams, etc. **If the high voltage buses are conductively isolated from each other, isolation resistance shall be measured for each electrical circuit.**

Moreover, modification necessary for measuring the isolation resistance may be carried out, such as removal of the cover in order to reach the live parts, drawing of measurement lines, change in software, etc.

In cases where the measured values are not stable due to the operation of the on-board isolation resistance monitoring system, ~~etc.~~, necessary modification for conducting the measurement may be carried out ~~by, such as~~ stopping of the operation of the device concerned or removing it. Furthermore, when the device is removed, **a set of drawings will be used to prove that it shall be proven, using drawings, etc., that it will not change** the isolation resistance between the live parts and the electrical chassis **remains unchanged.**

These modifications shall not influence the test results.

Utmost care shall be exercised as to short circuit ~~and~~, electric shock, ~~etc.~~, ~~for~~ since this confirmation might require direct operations of the high-voltage circuit.

2.1. Measurement method using DC voltage from ~~external~~ ~~off-vehicle~~ sources"

Annex 5A, paragraph 2.1.2., amend to read:

"2.1.2. Measurement method

An ~~insulator~~ **isolation** resistance test instrument shall ... "

Annex 5A, paragraph 2.2.3.4., amend to read:

"2.2.3.4. Fourth step

If $V_1 U_1$ is greater than or equal to $V_2 U_2$, insert a standard known resistance (R_o) between the negative side of the high voltage bus and the electrical chassis. With R_o installed, measure the voltage ($V_1' U_1'$) between the negative side of the high voltage bus and the electrical chassis (see Figure 2).

Calculate the electrical isolation (R_i) according to the following formula:

$$R_i = R_o * (V_b / V_1' - V_b / V_1) \text{ or } R_i = R_o * V_b U_b * (1 / V_1' U_1' - 1 / V_1 U_1)$$

...

If V_2U_2 is greater than V_1U_1 , insert a standard known resistance (R_o) between the positive side of the high voltage bus and the electrical chassis. With R_o installed, measure the voltage ($V_2'U_2'$) between the positive side of the high voltage bus and the electrical chassis (see Figure 3). ~~Calculate the electrical isolation (R_i) according to the formula shown. Divide this electrical isolation value (in Ω) by the nominal operating voltage of the high voltage bus (in volts).~~

Calculate the electrical isolation (R_i) according to the following formula:

$$R_i = R_o * (V_b/V_2' - V_b/V_2) \text{ or } R_i = R_o * V_b U_b * (1/V_2' U_2' - 1/V_2 U_2)$$

..."

Annex 5A, paragraph 2.2.3.5., amend to read:

"2.2.3.5. Fifth step

The electrical isolation ...high voltage bus (in ~~V volts~~) results

Note: The standard ... plus/minus 20 per cent (in ~~V volts~~). R_o is ... "

Annex 5B, paragraphs 1. to 1.1., Amend to read:

"1. Measurement method

The isolation resistance measurement shall be conducted by selecting an appropriate measurement method from among those listed in paragraphs 1.1. through 1.2. of this ~~a~~Annex, depending on the electrical charge of the live parts or the isolation resistance, etc.

Megohmmeter or oscilloscope measurements are appropriate alternatives to the procedure described below for measuring isolation resistance. In this case, it may be necessary to deactivate the on-board isolation resistance monitoring system.

The range of the electrical circuit to be measured shall be clarified in advance, using electrical circuit diagrams, etc. If the high voltage buses are galvanically isolated from each other, isolation resistance shall be measured for each electrical circuit.

If the operating voltage of the ~~tested device~~ **Tested-Device** ($V_b U_b$, Figure 1) cannot be measured (e.g. due to disconnection of the electric circuit caused by main contactors or fuse operation) the test may be performed with a modified test device to allow measurement of the internal voltages (upstream the main contactors).

~~These modifications shall not influence the test results.~~

~~The range of the electrical circuit to be measured shall be clarified in advance, using electrical circuit diagrams, etc. If the high voltage buses are galvanically isolated from each other, isolation resistance shall be measured for each electrical circuit.~~ Moreover, modification necessary for measuring the isolation resistance may be carried out, such as removal of the cover in order to reach the live parts, drawing of measurement lines, change in software, etc.

In cases where the measured values are not stable due to the operation of the isolation resistance monitoring system, ~~etc.~~, necessary modification for conducting the measurement may be carried out ~~by, such as~~ stopping the operation of the device concerned or removing it. Furthermore, when the device is removed, **a set of drawings will be used to prove that it shall be**

~~proven, using drawings, etc., that it will not change~~ the isolation resistance between the live parts and the ground connection designated by the manufacturer as a point to be connected to the electrical chassis when installed on the vehicle **remains unchanged**.

These modifications shall not influence the test results.

Utmost care shall be exercised as to short circuit **and** electric shock, ~~etc., for~~ **since** this confirmation might require direct operations of the high-voltage circuit.

- 1.1. Measurement method using **DC** voltage from external sources"

Annex 5B, paragraph 1.2.3.4., amend to read:

"1.2.3.4. Fourth step

If $V_1 - U_1$ is greater than or equal to $V_2 U_2$, insert a standard known resistance (R_o) between the negative pole of the ~~tested device~~ **Tested-Device** and the ground connection. With R_o installed, measure the voltage ($V_1' - U_1'$) between the negative pole of the ~~tested device~~ **Tested-Device** and the ground connection (see Figure 2).

Calculate the electrical isolation (R_i) according to the following formula:

Calculate the electrical isolation (R_i) according to the following formula:

$$R_i = R_o * (V_b / V_1' - V_b / V_1) \text{ or } R_i = R_o * V_b U_b * (1 / V_1' - U_1' - 1 / V_1 U_1)$$

...

If $V_2 - U_2$ is greater than $V_1 U_1$, insert a standard known resistance (R_o) between the positive pole of the ~~tested device~~ **Tested-Device** and the ground connection. With R_o installed, measure the voltage ($V_2' - U_2'$) between the positive pole of the ~~tested device~~ **Tested-Device** and the ground connection (see Figure 3).

Calculate the electrical isolation (R_i) according to the following formula:

$$R_i = R_o * (V_b / V_2' - V_b / V_2) \text{ or } R_i = R_o * V_b U_b * (1 / V_2' - U_2' - 1 / V_2 U_2)$$

..."

Annex 5B, paragraph 1.2.3.5., amend to read:

"1.2.3.5. Fifth step

The electrical isolation ...the ~~tested device~~ **Tested-Device** (in **Vvolts**) results
....

Note: The standard ... ~~tested device~~ **Tested-Device** plus/minus 20 per cent (in **Vvolts**). R_o is ... "

Renumber (former) Annex 5 as Annex 6, and amend to read;

" Annex 65

Confirmation method for function of on-board isolation resistance monitoring system

The on-board isolation resistance monitoring system shall be tested using the following procedure.

- (a) Determine the isolation resistance, R_i , of the electric power train with the electrical isolation monitoring system using the procedure outlined Annex 5A.
- (b) If the minimum isolation resistance value required in accordance with paragraphs 5.1.3.1. or 5.1.3.2. is $100 \Omega/V$, insert a resistor with resistance R_o between either side of the high voltage bus that exhibit lower value in U_1 or U_2 measured in accordance with Paragraph 2.2.3. of Annex 5A and the electrical chassis. The magnitude of the resistor, R_o , shall be such that:

$$1/(1/(95xU) - 1/R_i) \leq R_o < 1/(1/(100xU) - 1/R_i)$$

where U is the working voltage of the electric power train.

- (c) If the minimum isolation resistance value required in accordance with paragraphs 5.1.3.1. or 5.1.3.2. is $500 \Omega/V$, insert a resistor with resistance R_o between either side of the high voltage bus that exhibit lower value in U_1 or U_2 measured in accordance with Paragraph 2.2.3. of Annex 5A and the electrical chassis. The magnitude of the resistor, R_o , shall be such that:

$$1/(1/(475xU) - 1/R_i) \leq R_o < 1/(1/(500xU) - 1/R_i)$$

where U is the working voltage of the electric power train.

~~The function of the on board isolation resistance monitoring system shall be confirmed by the following method:~~

~~Insert a resistor that does not cause the isolation resistance between the terminal being monitored and the electrical chassis to drop below the minimum required isolation resistance value. The warning shall be activated. "~~

~~Remove (former) Annex 6 part 3.~~

Insert new Annex 7A and Annex 7B, to read;

" Annex 7A

Verification method for testing authorities confirming document based isolation resistance compliance of electrical design of the vehicle after water exposure

This Annex describes the applicable requirements when certifying the manufacturers' high voltage equipment or system components against adverse water effects rather than a physical test. As a general rule, the electrical design or components of the vehicles shall comply with the requirements as specified in paragraphs "5.1.1. Protection against direct contact", "5.1.2. Protection against indirect contact", and "5.1.3. Isolation resistance" respectively and this will be separately verified by the testing authority. Vehicle manufacturers shall provide information to testing authorities to identify, as a point of reference, the mounting location for each high-voltage component in/on the vehicle.

1. Documentation shall contain the following information:
 - (a) on how the manufacturer tested isolation resistance compliance of electrical design of the vehicle by using fresh water;
 - (b) on how, after the test had been carried out, the high-voltage component or system was inspected for ingress of water and how, depending on its mounting location, each high voltage component/system met the appropriate degree of protection against water.
2. The testing authority will verify and confirm the authenticity of documented conditions that have been observed, and should have been complied with, during the process of certification by manufacturer:
 - 2.1. It is permitted that, during the test, the moisture contained inside the enclosure is partly condensed. The dew which may be deposited is not considered as ingress of water. For the purpose of the tests, the surface area of the tested high-voltage component or system is calculated with an accuracy of 10 per cent. If possible, the tested high-voltage component or system is run energized. If the tested high-voltage component or system is energized, adequate safety precautions are taken.
 - 2.2. For electrical components, externally attached (e.g. in engine compartment), open underneath, both exposed or protected locations, the testing authority shall verify, with a view to confirming the compliance, whether the test is conducted by spraying the high-voltage component or system from all practicable directions with a stream of water from a standard test nozzle as shown in Figure 1. The following parameters are observed during the test in particular:
 - (a) Nozzle internal diameter: 6.3 mm;
 - (b) Delivery rate: 11.9 – 13.2 l/min;
 - (c) Water pressure at the nozzle: approximately 30 kPa (0.3 bar);
 - (d) Test duration per m² of surface area of the tested high-voltage component or system: 1 min;
 - (e) Minimum test duration: 3 min;

- (f) Distance from nozzle to tested high-voltage component or system surface: approximately 3 m (this distance may be reduced, if necessary to ensure proper wetting when spraying upwards).

Figure 1
Standard nozzle for the test

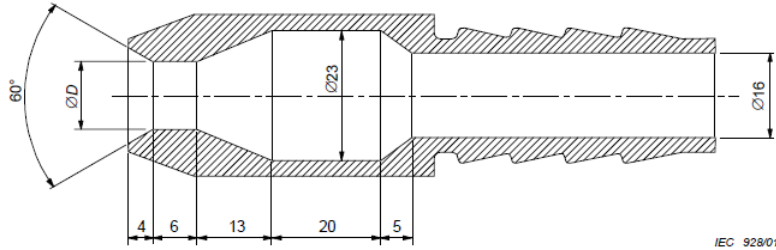

Dimensions in millimetres

D is 6.3 mm as specified in (a) above.

2.3. For electrical components, externally attached (e.g. in engine compartment), covered from underneath, the testing authority shall verify, with a view to confirming the compliance, whether:

- (a) The cover protects the component against direct spray water from underneath and is not visible;
- (b) The test is conducted by using splashing test nozzle as shown in Figure 2;
- (c) The moving shield is removed from the spray nozzle and the machine is sprayed from all practicable directions;
- (d) The water pressure is adjusted to give a delivery rate of (10 ± 0.5) l/min (pressure approximately 80 kPa to 100 kPa (0.8 bar to 1.0 bar));
- (e) The test duration is 1 min/m^2 of calculated surface area of the machine (excluding any mounting surface and cooling fin) with a minimum duration of 5 min.

Figure 2
Splashing test nozzle

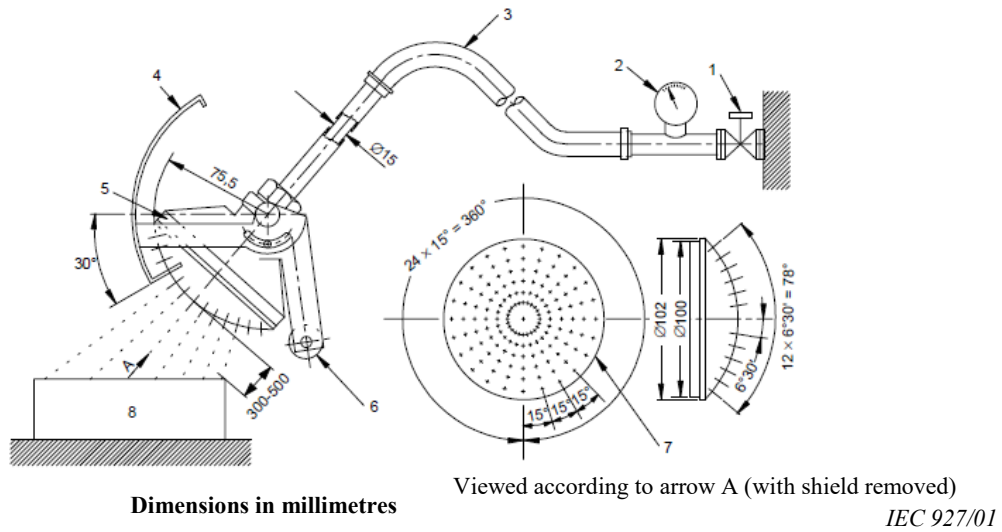

Dimensions in millimetres

Note:

- | | |
|---|--|
| <ul style="list-style-type: none"> 1. Cock 2. Pressure gauge 3. Hose 4. Moving shield – aluminium 5. Spray nozzle 6. Counter weight | <ul style="list-style-type: none"> 7. Spray nozzle – brass with 121 holes $\varnothing 0,5$: <ul style="list-style-type: none"> 1. hole in centre 2. inner circle of 12 holes at 30° pitch 4. outer circle of 24 holes at 15° pitch 8. Machine under test |
|---|--|
3. The entire high voltage system or each component is checked to comply with the isolation resistance requirement in paragraph 5.1.3. with the following conditions:
 - (a) The electric chassis shall be simulated by an electric conductor, e.g. a metal plate, and the components are attached with their standard mounting devices to it.
 - (b) Cables, where provided, shall be connected to the component.
 4. The parts designed not to be wet during operation are not allowed to be wet and no accumulation of water which could have reached them is tolerated inside the high-voltage component or system.

Annex 7B

Vehicle-based test procedure for Protection against water effects.

1. Washing.

This test is intended to simulate the normal washing of vehicles, but not specific cleaning using high water pressure or underbody washing.

The areas of the vehicle regarding this test are border lines, i.e. a seal of two parts such as flaps, glass seals, outline of opening parts, outline of front grille and seals of lamps.

All border lines shall be exposed and followed in all directions with the water stream using a hose nozzle and conditions in accordance with IPX5 as specified in Annex 7A.

2. Driving through standing water.

The vehicle shall be driven in a wade pool, with 10 cm water depth, over a distance of 500 m at a speed of 20 km/h, in a time of approximately 1.5 min. If the wade pool used is less than 500 m in length, then the vehicle shall be driven through it several times. The total time, including the periods outside the wade pool, shall be less than 10 min. "

Renumber (former) Annex 7 (including its Appendix) as Annex 8.

Annex 8, paragraph 2., amend to read:

"2. Description of test

The hydrogen emission test (Figure 17-1 of the present Annex 8) is ... "

Annex 8, paragraph 3.2.1., amend to read:

"3.2.1. The REESS shall be in good mechanical condition and have been subject to minimum of 5 standard cycles (as specified in Annex 98, Appendix 1)."

Renumber (former) Annex 7 Figure 7.1 as Annex 8 Figure 1.

Annex 8, paragraph 4.2., amend to read:

"4.2. Hydrogen emission measurement enclosure

The hydrogen emission measurement enclosure shall be a gas-tight measuring chamber able to contain...in accordance with Annex 8, Appendix 1 to this annex. The inner surface ...

To accommodate... as specified in Annex 8, Appendix 1 to this annex.

Any method of volume accommodation shall limit the differential between the enclosure internal pressure and the barometric pressure to a maximum value of ± 5 hPa.

...

The enclosure shall ... (see Annex 87, Appendix 1, paragraph 2.1.1.), taking ... "

Annex 8, paragraph 4.8.2., amend to read:

"4.8.2. Calibration ...specified in **Annex 8**, Appendix 1 may ..."

Annex 8, paragraph 5.1.1.1., amend to read:

"5.1.1.1. Discharges and initial charges of the REESS

The procedure starts ... at a steady speed of 70 ~~per cent~~ ± 5 per cent of the maximum ..."

Annex 8, paragraphs 5.1.2. to 5.1.3., amend to read:

"5.1.2. Discharge of the REESS

The REESS is discharged ... at a steady speed of 70 ~~per cent~~ ± 5 per cent from the maximum ...

5.1.3. Soak

Within fifteen ... in paragraph 5.1.2., the vehicle "

Annex 8, paragraph 5.1.4.6., amend to read:

"5.1.4.6. The start of calculation (**Annex 8**, paragraph 6. ~~of this annex~~). The ambient ..."

Annex 8, paragraph 5.1.4.9., amend to read:

"5.1.4.9. The end of ... sampling, as specified in **Annex 8**, paragraph 5.1.4.6. ~~of this annex~~. The different ... the calculation in **Annex 8**, paragraph 6. ~~of this annex~~."

Annex 8, paragraphs 5.1.5.1. to 5.1.5.2., amend to read:

"5.1.5.1. Within seven days ... according to **Annex 8**, paragraph 5.1.2. ~~of this annex~~.

5.1.5.2. The steps of the procedure in **Annex 8**, paragraph 5.1.3. ~~of this annex~~ shall be repeated. "

Annex 8, paragraph 5.1.5.8., amend to read:

"5.1.5.8. The start of ... calculation (**Annex 8**, paragraph 6. ~~of this annex~~) The ambient ..."

Annex 8, paragraph 5.1.5.11., amend to read:

"5.1.5.11. The end of ... calculation in **Annex 8**, paragraph 6. ~~of this annex~~.

Annex 8, paragraphs 5.2.2. to 5.2.3., amend to read:

"5.2.2. Discharge of the REESS

The REESS is discharged at 70 ~~per cent~~ ± 5 per cent of ...

5.2.3. Soak

Within 15 minutes of ... soaked at 293 ~~K~~ ± 2 K for a minimum ..."

Annex 8, paragraph 5.2.4.6., amend to read:

"5.2.4.6. The start of ... calculation (**Annex 8**, paragraph 6. ~~of this annex~~) The ambient enclosure ..."

Annex 8, paragraph 5.2.4.9., amend to read:

"5.2.4.9. The end of ... calculation in **Annex 8**, paragraph 6. ~~of this annex~~"

Annex 8, paragraph 5.2.5.8., amend to read:

"5.2.5.8. The start of ... calculation (~~Annex 8, paragraph 6. of this annex~~) The ambient ..."

Annex 8, Appendix 1, paragraph 2.1.3., amend to read:

"2.1.3. The chamber shall be checked as in **Annex 8**, paragraph 2.3. ~~of this annex~~. If ..."

Annex 8, Appendix 1, paragraph 2.2.8., amend to read:

"2.2.8. The change in mass ... with **Annex 8**, paragraph 2.4. ~~of this annex~~ and shall not exceed 0.5 g. "

Annex 8, Appendix 1, paragraph 3., amend to read:

"3. Calibration of the hydrogen analyser

The analyser should ... See **Annex 8**, paragraph 4.8.2. ~~of Annex 7.~~

Each of ..."

Renumber (former) Annex 8 (including its Appendix) as Annex 9.

Annex 9 – Appendix 1, amend to read:

" **Annex 98** - Appendix 1

Procedure for conducting a standard cycle

A standard cycle ~~will~~ **shall** start with a standard discharge followed by a standard charge. **The standard cycle shall be conducted at an ambient temperature of 20 ± 10 °C.**

Standard discharge:

Discharge rate: The discharge procedure including termination criteria shall be defined by the manufacturer. If not specified, then it shall be a discharge with 1C current **for a complete REESS and REESS subsystems.**

Discharge limit (end voltage): Specified by the manufacturer

For a complete vehicle, discharge procedure using a dynamometer shall be defined by the manufacturer. Discharge termination will be according to vehicle controls.

Rest period after discharge: Minimum ~~30~~ **15** min

Standard charge:

The charge procedure ~~including termination criteria~~ shall be defined by the manufacturer. If not specified, then it shall be a charge with C/3 current. **Charging is continued until normally terminated. Charge termination shall be according to paragraph 2. of Annex 9 Appendix 2 for REESS or REESS subsystem.**

For a complete vehicle that can be charged by an external source, charge procedure using an external electric power supply shall be defined by the manufacturer. For a complete vehicle that can be charged by on-board energy sources, a charge procedure using a dynamometer shall be defined by the manufacturer. Charge termination will be according to vehicle controls. "

Insert new Annex 9 – Appendix 2, to read:

"Annex 9 - Appendix 2

Procedure for SOC adjustment

1. **The adjustment of SOC shall be conducted at an ambient temperature of 20 ± 10 °C for vehicle-based tests and 22 ± 5 °C for component-based tests.**
2. **The SOC of the Tested-Device shall be adjusted according to one of the following procedures as applicable. Where different charging procedures are possible, the REESS shall be charged using the procedure which yields the highest SOC:**
 - (a) **For a vehicle with a REESS designed to be externally charged, the REESS shall be charged to the highest SOC in accordance with the procedure specified by the manufacturer for normal operation until the charging process is normally terminated.**
 - (b) **For a vehicle with a REESS designed to be charged only by an energy source on the vehicle, the REESS shall be charged to the highest SOC which is achievable with normal operation of the vehicle. The manufacturer shall advise on the vehicle operation mode to achieve this SOC.**
 - (c) **In case that the REESS or REESS sub-system is used as the Tested-Device, the Tested-Device shall be charged to the highest SOC in accordance with the procedure specified by the manufacturer for normal use operation until the charging process is normally terminated. Procedures specified by the manufacturer for manufacturing, service or maintenance may be considered as appropriate if they achieve an equivalent SOC as for that under normal operating conditions. In case the Tested-Device does not control SOC by itself, the SOC shall be charged to not less than 95 per cent of the maximum normal operating SOC defined by the manufacturer for the specific configuration of the Tested-Device.**
3. **When the vehicle or REESS subsystem is tested, the SOC shall be no less than 95 per cent of the SOC according to paragraphs 1. and 2. above for REESS designed to be externally charged and shall be no less than 90 per cent of SOC according to paragraphs 1. and 2. above for REESS designed to be charged only by an energy source on the vehicle. The SOC will be confirmed by a method provided by the manufacturer."**

Renumber (former) Annex 8A as Annex 9A.

Annex 9A, paragraphs 2.1. to 2.2., amend to read:

- "2.1. This test shall be conducted either with the complete REESS or with a related REESS subsystem(s) including the cells and their electrical connections. If the manufacturer chooses to test with related REESS subsystem(s), the manufacturer shall demonstrate that the test result can reasonably represent the

performance of the complete REESS with respect to its safety performance under the same conditions. If the electronic management unit for the REESS is not integrated in the casing enclosing the cells, then the electronic management unit may be omitted from installation on the ~~tested device~~ **Tested-Device** if so requested by the manufacturer.

- 2.2. The ~~tested device~~ **Tested-Device** shall be firmly secured to the platform of the vibration machine in such a manner as to ensure that the vibrations are directly transmitted to the ~~tested device~~ **Tested-Device**.

The Tested-Device should be mounted with its original mounting points, if those exist in the Tested-Device, as mounted in the vehicle."

Annex 9A, paragraphs 3.1. to 3.2., amend to read:

- "3.1. General test conditions

The following conditions shall apply to the ~~tested device~~ **Tested-Device**:

- (a) The test shall be conducted at an ambient temperature of ~~2220~~ **22 ± 5** °C;
- (b) At the beginning of the test, the SOC shall be adjusted **in accordance with Annex 9, Appendix 2** ~~to a value in the upper 50 per cent of the normal operating SOC range of the tested device;~~
- (c) At the beginning ...

- 3.2. Test procedures

The ~~tested devices~~ **Tested-Device** shall be ...

At the request of ... limited to **the installation** ~~approvals~~ for a ..."

Renumber (former) Annex 8B as Annex 9B.

Annex 9B, paragraph 2., amend to read:

- "2. Installations

This test shall be conducted either with the complete REESS or with ~~related REESS subsystem(s) of the REESS including the cells and their electrical connections.~~ **related** REESS subsystem(s), the manufacturer shall ...

Annex 9B, paragraphs 3.1. to 3.2., amend to read:

- "3.1. General test conditions

The following conditions shall apply to the ~~tested device~~ **Tested-Device** at the start of the test:

- (a) The SOC shall be adjusted **in accordance with Annex 9, Appendix 2** ~~to a value in the upper 50 per cent of the normal operating SOC range;~~
- (b) All protection devices, which would affect the function of the ~~tested device~~ **Tested-Device** and which are relevant to the outcome of the test shall be operational.

- 3.2. Test procedure

The ~~tested device~~ **Tested-Device** shall be ...at an ambient temperature of ~~20~~ **22 ± 5** °C.

After the storage ...in Annex ~~89~~, Appendix 1 shall be ..."

Renumber (former) Annex 8C as Annex 9C.

Annex 9C, paragraph 2.1., amend to read:

"2.1. This test shall be conducted either with the complete REESS or with ~~related~~ REESS subsystem(s) ~~including the cells and their electrical connections~~. If the manufacturer chooses to test with ~~related~~ REESS subsystem(s), the manufacturer shall ...

Annex 9C, paragraphs 3.1. to 3.2., amend to read:

"3.1. General test conditions and requirements

The following condition shall apply to the test:

- (a) The test shall be conducted at an ambient temperature of 20 ± 10 °C,
- (b) At the beginning of the test, the SOC shall be adjusted **in accordance with Annex 9, Appendix 2** ~~to a value in the upper 50 per cent of the normal operating SOC range;~~
- (c) At the beginning of the test, all protection devices which ~~effect~~ **affect** the function of the ~~tested device~~ **Tested-Device** and which are relevant to the outcome of the test, shall be operational.

3.2. Test procedure

The ~~tested device~~ **Tested-Device** shall be decelerated or, ~~at the choice of the applicant,~~ accelerated in compliance with the acceleration corridors which are specified in Tables 1 to 3. ~~The Technical Service in consultation with the manufacturer shall decide ...~~

The test shall end with an observation period of 1 h at the ambient temperature conditions of the test environment."

Renumber (former) Annex 8D as Annex 9D.

Annex 9D, paragraph 2.1., amend to read:

"2.1. This test shall be conducted either with the complete REESS or with ~~related~~ REESS subsystem(s) ~~including the cells and their electrical connections~~. If the manufacturer chooses to test with ~~related~~ REESS subsystem(s), the manufacturer shall ..."

Annex 9D, paragraphs 3.1. to 3.2., amend to read:

"3.1. General test conditions

The following condition and requirements shall apply to the test:

- (a) The test shall be conducted at an ambient temperature of 20 ± 10 °C;
- (b) At the beginning of the test, the SOC shall be adjusted **in accordance with Annex 9, Appendix 2** ~~to a value in the upper 50 per cent of the normal operating SOC range;~~
- (c) At the beginning of the test, all internal and external protection devices which would affect the function of the ~~tested device~~ **Tested-Device** and which are relevant to the outcome of the test shall be operational.
- (d) **In case where Paragraph 6.4.2.1.2. is applied, vehicle body structure, electrical protection barriers, enclosures, or other mechanical functional devices providing protection against contact regardless of whether outside or inside of the REESS may be**

attached to the Tested-Device if so requested by the manufacturer. The manufacturer shall define the relevant parts used for the mechanical protection of the REESS. The test may be conducted with the REESS mounted to this vehicle structure in a way which is representative of its mounting in the vehicle.

3.2. Crush test

3.2.1. Crush force

The ~~tested device~~ **Tested-Device** shall be ...

The application of ... by the manufacturer ~~together with the Technical Service~~ having consideration ..."

Renumber (former) Annex 8E (including its Appendix) as Annex 9E.

Annex 9E, paragraph 2.1., amend to read:

"2.1. This test shall be conducted either with the complete REESS or with ~~related~~ REESS subsystem(s) ~~including the cells and their electrical connections~~. If the manufacturer chooses to test with ~~related~~ REESS subsystem(s), the manufacturer shall ...

Annex 9E, paragraph 3.1., amend to read:

"3.1. General test conditions

The following requirements and conditions shall apply to the test:

- (a) The test shall be conducted at a temperature of at least 0 °C;
- (b) At the beginning of the test, the SOC shall be adjusted **in accordance with Annex 9, Appendix 2** ~~to a value in the upper 50 per cent of the normal operating SOC range;~~
- (c) At the beginning of the test, all protection devices which ~~effect~~ **affect** the function of the ~~tested device~~ **Tested-Device** and are relevant for the outcome of the test shall be operational. "

Annex 9E, paragraph 3.2.2., amend to read:

"3.2.2. Component based test

In case of component based test, the manufacturer may choose either Gasoline pool fire test or LPG burner test.

The ~~tested device~~ **Tested-Device** shall be ..."

Annex 9E, paragraph 3.3., amend to read:

"3.3. **Gasoline pool fire test set up for both vehicle-based and component-based test.**

The flame to which ...

Renumber Annex 9E, paragraph 3.4., as Annex 9E, paragraph 3.3.1.

Renumber Annex 9E, paragraph 3.5., as Annex 9E, paragraph 3.3.2., and amend to read;

"~~3.3.25.~~ During phase C ..., as prescribed in Annex ~~8E-9E~~ - Appendix 1. There shall be ..."

Renumber Annex 9E, paragraph 3.6., as Annex 9E, paragraph 3.3.3.

Renumber Annex 9E, paragraph 3.7., as Annex 9E, paragraph 3.3.4.

Renumber Annex 9E, paragraphs 3.7.1 to 3.7.2., as Annex 9E, paragraphs 3.3.4.1. to 3.3.4.2.

Renumber Annex 9E, paragraph 3.7.3., as Annex 9E, paragraph 3.3.4.3., and amend to read:
"3.7.3.4.3. Phase C: Indirect exposure to flame (Figure 3)

As soon as ... 60 seconds.

~~However this shall only be permitted where it is demonstrable to the satisfaction of the Technical Service that it will not result in a reduction in the severity of the test."~~

Renumber Annex 9E, paragraph 3.7.4., as Annex 9E, paragraph 3.3.4.4.

Insert new Annex 9E paragraphs 3.4. to 3.4.7., to read:

"3.4. LPG burner fire test set up for component based test

3.4.1. The Tested-Device shall be placed on a test equipment, in the position that the manufacturer's design intends.

3.4.2. LPG burner shall be used to produce flame to which the Tested-Device is exposed. The height of the flame shall be about 60 cm or more, without the Tested-Device.

3.4.3. The flame temperature shall be measured continuously by temperature sensors. An average temperature shall be calculated, at least every second for the duration of the whole fire exposure, as the arithmetic average of temperatures measured by all temperature sensors fulfilling the location requirements described in paragraph 3.4.4.

3.4.4. All temperature sensors shall be installed at a height of 5 ± 1 cm below the lowest point of the Tested-Device's external surface when oriented as described in paragraph 3.4.1. At least one temperature sensor shall be located at the centre of Tested-Device, and at least four temperature sensors shall be located within 10 cm from the edge of the Tested-Device towards its centre with nearly equal distance between the sensors.

3.4.5. The bottom of Tested-Device shall be exposed to the even flame directly and entirely by fuel combustion. LPG burner flame shall exceed the horizontal projection of the Tested-Device by at least 20 cm.

3.4.6. An average temperature of 800 °C shall be reached within 30 seconds and maintained between 800 – 1,100 °C The Tested-Device shall then be exposed to the flame for 2 minutes.

3.4.7. After direct exposure to flame the Tested-Device shall be observed until such time as the surface temperature of the Tested-Device has decreased to ambient temperature or has been decreasing for a minimum of 3 hours."

Renumber (former) Annex 8F as Annex 9F.

Annex 9F, paragraphs 1. to 3.2., amend to read:

"1. Purpose

The purpose of this test is to verify the performance of the short circuit protection. ~~This functionality, if implemented, shall interrupt or limit the short~~

~~circuits~~ to prevent the REESS from any further related severe events caused by short circuit current.

2. Installations

This test shall be conducted either **with a complete vehicle or** with the complete REESS or with ~~the related~~ REESS subsystem(s), ~~including the cells and their electrical connections~~. If the manufacturer chooses to test with ~~REESS-related~~ subsystem(s), **the Tested-Device shall be able to deliver the nominal voltage of the complete REESS and** the manufacturer shall demonstrate that the test result can reasonably represent the performance of ... on the ~~tested device~~ **Tested-Device** if so requested by the manufacturer.

For a test with a complete vehicle, the manufacturer may provide information to connect a breakout harness to a location just outside the REESS that would permit applying a short circuit to the REESS.

3. Procedures

3.1. General test conditions

The following condition shall apply to the test:

- (a) The test shall be conducted at a ambient temperature of 20 ± 10 °C or at higher temperature if requested by the manufacturer;
- (b) At the beginning of the test, the SOC shall be adjusted **in accordance with Annex 9, Appendix 2** ~~to a value in the upper 50 per cent of the normal operating SOC range;~~
- (c) At the beginning of the test, all protection devices which would affect the function of the ~~tested device~~ **Tested-Device** and which are relevant to the outcome of the test shall be operational.
- (d) **For testing with a complete vehicle, a breakout harness is connected to the manufacturer specified location and vehicle protection systems relevant to the outcome of the test shall be operational.**

3.2. Short circuit

At the start ... be conducted.

For testing with a complete REESS or REESS subsystem(s), ~~the positive and negative terminals of the tested device~~ **Tested-Device** shall be connected to each other to produce a short circuit. The connection ... 5 mΩ.

For testing with a complete vehicle, the short circuit is applied through the breakout harness. The connection used for creating the short circuit (including the cabling) shall have a resistance not exceeding 5 mΩ.

The short circuit condition shall be continued until the **protection function** operation of the REESS ~~terminate 's protection function to interrupt or limit~~ the short circuit current ~~is confirmed~~, or for at least **1 hour** ~~one hour~~ after the temperature measured on the casing of the ~~tested device~~ **Tested-Device** has stabilised, such that the temperature gradient varies by a less than 4 °C through ~~±2~~ hours.

3.3. Standard cycle and observation period

Directly after the termination of the short circuit a standard cycle as described in Annex 89, Appendix 1 shall be conducted, if not inhibited by the ~~tested-device~~ **Tested-Device**.

The test shall ..."

Renumber (former) Annex 8G as Annex 9G, and amend to read:

" Annex 8G9G

Overcharge protection

1. Purpose

The purpose of this test is to verify the performance of the overcharge protection **to prevent the REESS from any further related severe events caused by a too high SOC.**

2. Installations

This test shall be conducted, under standard operating conditions, either **with a complete vehicle or** with the complete REESS ~~(this maybe a complete vehicle) or with related REESS subsystem(s), including the cells and their electrical connections. If the manufacturer chooses to test with related subsystem(s), the manufacturer shall demonstrate that the test result can reasonably represent the performance of the complete REESS with respect to its safety performance under the same conditions.~~ **Ancillary systems that do not influence the test results may be omitted from the Tested-Device.**

The test may be performed with a modified ~~tested-device~~ **Tested-Device** as ~~agreed by the manufacturer and the Technical Service.~~ **provided** ~~†~~ these modifications shall not influence the test results.

3. Procedures

3.1. General test conditions

The following requirements and conditions shall apply to the test:

- (a) The test shall be conducted at an ambient temperature of 20 ± 10 °C or at higher temperature if requested by the manufacturer;
- (b) **The SOC of REESS shall be adjusted around the middle of normal operating range by normal operation recommended by the manufacturer such as driving the vehicle or using an external charger. The accurate adjustment is not required as long as the normal operation of the REESS is enabled;**
- (c) **For vehicle-based test of vehicles with on-board energy conversion systems (e.g. internal combustion engine, fuel cell, etc.), fill the fuel to allow the operation of such energy conversion systems;**
- (b) At the beginning of the test, all protection devices which would affect the function of the ~~tested-device~~ **Tested-Device** and which are relevant to the outcome of the test shall be operational. **All relevant main contactors for charging shall be closed.**

3.2. Charging

The procedure for charging the REESS for vehicle-based test shall be in accordance with paragraphs 3.2.1. and 3.2.2. and shall be selected as appropriate for the relevant mode of vehicle operation and the functionality of the protection system. Alternatively, the procedure for charging the REESS for vehicle-based test shall be in accordance with paragraph 3.2.3. For component-based test, the charging procedure shall be in accordance with paragraph 3.2.4.

3.2.1. Charge by vehicle operation.

This procedure is applicable to the vehicle-based tests in active driving possible mode:

- (a) For vehicles that can be charged by on-board energy sources (e.g. energy recuperation, on-board energy conversion systems), the vehicle shall be driven on a chassis dynamometer. The vehicle operation on a chassis dynamometer (e.g. simulation of continuous down-hill driving) that will deliver as high charging current as reasonably achievable shall be determined, if necessary, through consultation with the manufacturer.
- (b) The REESS shall be charged by the vehicle operation on a chassis dynamometer in accordance with paragraph 3.2.1.(a). The vehicle operation on the chassis dynamometer shall be terminated when the vehicle's overcharge protection controls terminates the REESS charge current or the temperature of the REESS is stabilized such that the temperature varies by a gradient of less than 2 °C through 1 hour. Where an automatic interrupt function vehicle's overcharge protection control fails to operate, or if there is no such control function, the charging shall be continued until the REESS temperature reaches 10 °C above its maximum operating temperature specified by the manufacturer.
- (c) Immediately after the termination of charging, one standard cycle as described in Annex 9, Appendix 1 shall be conducted, if it is not prohibited by the vehicle, with vehicle operation on a chassis dynamometer.

3.2.2. Charge by external electricity supply (vehicle-based test).

This procedure is applicable to vehicle-based test for externally chargeable vehicles:

- (a) The vehicle inlet for normal use, if it exists, shall be used for connecting the external electricity supply equipment. The charge control communication of the external electricity supply equipment shall be altered or disabled to allow the charging specified in paragraph 3.2.2.(b) below;
- (b) The REESS shall be charged by the external electricity supply equipment with the maximum charge current specified by the manufacturer. The charging shall be terminated when the vehicle's overcharge protection control terminates the REESS charge current. Where vehicle's overcharge protection control fails to operate, or if there is no such control, the charging shall be continued until the REESS temperature reaches 10 °C above its maximum operating temperature specified by the manufacturer. In the case where charge current is not terminated and where the

REESS temperature remains less than 10 °C above the maximum operating temperature, vehicle operation shall be terminated 12 hours after the start of charging by external electricity supply equipment;

- (c) Immediately after the termination of charging, one standard cycle as described in Annex 9, Appendix 1 shall be conducted, if it is not prohibited by the vehicle, with vehicle operation on a chassis dynamometer for discharging and with external electricity supply equipment for charging.

3.2.3. Charge by connecting breakout harness (vehicle-based test).

This procedure is applicable to vehicle-based tests for both externally chargeable vehicles and vehicles that can be charged only by on-board energy sources and for which the manufacturer provides information to connect a breakout harness to a location just outside the REESS that permits charging of the REESS:

- (a) The breakout harness is connected to the vehicle as specified by the manufacturer. The trip current/voltage setting of the external charge-discharge equipment shall be at least 10 per cent higher than the current/voltage limit of the Tested-Device. The external electricity supply equipment is connected to the breakout harness. The REESS shall be charged by the external electricity power supply with the maximum charge current specified by the manufacturer;
- (b) The charging shall be terminated when the vehicle's overcharge protection control terminates the REESS charge current. Where vehicle's overcharge protection control fails to operate, or if there is no such control, the charging shall be continued until the REESS temperature is 10 °C above its maximum operating temperature specified by the manufacturer. In the case where charge current is not terminated and where the REESS temperature remains less than 10 °C above the maximum operating temperature, vehicle operation shall be terminated 12 hours after the start of charging by external electricity supply equipment;
- (c) Immediately after the termination of charging, one standard cycle as described in Annex 9, Appendix 1 (for a complete vehicle) shall be conducted, if it is not prohibited by the vehicle.

3.2.4. Charge by external electricity supply (component-based test).

This procedure is applicable to component-based test:

- (a) The external charge/discharge equipment shall be connected to the main terminals of the REESS. The charge control limits of the test equipment shall be disabled;
- (b) The REESS shall be charged by the external charge/discharge equipment with the maximum charge current specified by the manufacturer. The charging shall be terminated when the REESS overcharge protection control terminates the REESS charge current. Where overcharge protection control of the REESS fails to operate, or if there is no such control, the charging shall be continued until the REESS temperature reaches 10 °C above its maximum operating temperature specified by the manufacturer. In

the case where charge current is not terminated and where the REESS temperature remains less than 10 °C above the maximum operating temperature, the charging shall be terminated 12 hours after the start of charging by external electricity supply equipment;

- (c) Immediately after the termination of charging, one standard cycle as described in Annex 9, Appendix 1 shall be conducted, if it is not prohibited by the REESS, with external charge-discharge equipment.

~~At the beginning all relevant main contactors for charging shall be closed.~~

~~The charge control limits of the test equipment shall be disabled.~~

~~The tested device shall be charged with a charge current of at least 1/3C rate but not exceeding the maximum current within the normal operating range as specified by the manufacturer.~~

~~The charging shall be continued until the tested device (automatically) interrupts or limits the charging. Where an automatic interrupt function fails to operate, or if there is no such function the charging shall be continued until the tested device is charged to twice of its rated charge capacity.~~

- 3.3. ~~Standard cycle and observation period~~

~~Directly after the termination of charging a standard cycle as described in Annex 8, Appendix 1 shall be conducted, if not inhibited by the tested device.~~

The test shall end with an observation period of 1 h at the ambient temperature conditions of the test environment. "

Renumber (former) Annex 8H as Annex 9H, and amend to read:

" Annex 8H9H

Over-discharge protection

1. Purpose

The purpose of this test is to verify the performance of the over-discharge protection. ~~This functionality, if implemented, shall interrupt or limit the discharge current to prevent the REESS from any severe events caused by a too low SOC as specified by the manufacturer.~~

2. Installations

This test shall be conducted, under standard operating conditions, either **with a complete vehicle or** with the complete REESS ~~(this maybe a complete vehicle) or with related REESS subsystem(s), including the cells and their electrical connections. Ancillary systems that do not influence the test results may be omitted from the Tested-Device.~~ **If the manufacturer chooses to test with related subsystem(s), the manufacturer shall demonstrate that the test result can reasonably represent the performance of the complete REESS with respect to its safety performance under the same conditions.**

~~The test may be performed with a modified tested device~~ **Tested-Device as agreed by the manufacturer and the Technical Service, provided** ~~These modifications shall not influence the test results.~~

3. Procedures

3.1. General test conditions

The following requirements and condition shall apply to the test:

- (a) The test shall be conducted at an ambient temperature of 20 ± 10 °C or at higher temperature if requested by the manufacturer;
- (b) **The SOC of REESS shall be adjusted at the low level, but within normal operating range, by normal operation recommended by the manufacturer, such as driving the vehicle or using an external charger. Accurate adjustment is not required as long as the normal operation of the REESS is enabled;**
- (c) **For vehicle-based test of vehicles with on-board energy conversion systems (e.g. internal combustion engine, fuel cell, etc.), reduce the electrical energy from such on-board energy conversion systems, for example by adjusting the fuel level to nearly empty but enough so that the vehicle can enter into active driving possible mode;**
- (d) At the beginning of the test, all protection devices which would affect the function of the ~~tested device~~ **Tested-Device** and which are relevant for the outcome of the test shall be operational.

3.2. Discharging

The procedure for discharging the REESS for vehicle-based test shall be in accordance with paragraphs 3.2.1. and 3.2.2. Alternatively, the procedure for discharging the REESS for vehicle-based test shall be in accordance with paragraph 3.2.3. For component-based test, the discharging procedure shall be in accordance with paragraph 3.2.4.

3.2.1. Discharge by vehicle driving operation.

This procedure is applicable to the vehicle-based tests in active driving possible mode:

- (a) **The vehicle shall be driven on a chassis dynamometer. The vehicle operation on a chassis dynamometer (e.g. simulation of continuous driving at steady speed) that will deliver as constant discharging power as reasonably achievable shall be determined, if necessary, through consultation with the manufacturer;**
- (b) **The REESS shall be discharged by the vehicle operation on a chassis dynamometer in accordance with paragraph 3.2.1.(a). The vehicle operation on the chassis dynamometer shall be terminated when the vehicle's over-discharge protection control terminates REESS discharge current or the temperature of the REESS is stabilized such that the temperature varies by a gradient of less than 4 °C through 2 hours. Where an over-discharge protection control fails to operate, or if there is no such control, then the discharging shall be continued until the REESS is discharged to 25 per cent of its nominal voltage level;**
- (c) **Immediately after the termination of discharging, one standard charge followed by a standard discharge as described in Annex 9, Appendix 1 shall be conducted if it is not prohibited by the vehicle.**

3.2.2. Discharge by auxiliary electrical equipment (vehicle-based test).

This procedure is applicable to the vehicle-based tests in stationary condition:

- (a) The vehicle shall be switched in to a stationary operation mode that allow consumption of electrical energy from REESS by auxiliary electrical equipment. Such an operation mode shall be determined, if necessary, through consultation with the manufacturer. Equipments (e.g. wheel chocks) that prevent the vehicle movement may be used as appropriate to ensure the safety during the test;
- (b) The REESS shall be discharged by the operation of electrical equipment, air-conditioning, heating, lighting, audio-visual equipment, etc., that can be switched on under the conditions given in paragraph 3.2.2.(a). The operation shall be terminated when the vehicle's over-discharge protection control terminates REESS discharge current or the temperature of the REESS is stabilised such that the temperature varies by a gradient of less than 4 °C through 2 h. Where an over-discharge protection control fails to operate, or if there is no such control, then the discharging shall be continued until the REESS is discharged to 25 per cent of its nominal voltage level;
- (c) Immediately after the termination of discharging, one standard charge followed by a standard discharge as described in Annex 9, Appendix 1 shall be conducted if it is not prohibited by the vehicle.

3.2.3. Discharge of REESS using discharge resistor (vehicle-based test).

This procedure is applicable to vehicles for which the manufacturer provides information to connect a breakout harness to a location just outside the REESS that permits discharging the REESS:

- (a) Connect the breakout harness to the vehicle as specified by the manufacturer. Place the vehicle in active driving possible mode;
- (b) A discharge resistor is connected to the breakout harness and the REESS shall be discharged at a discharge rate under normal operating conditions in accordance with manufacturer provided information. A resistor with discharge power of 1 kW may be used;
- (c) The test shall be terminated when the vehicle's over-discharge protection control terminates REESS discharge current or the temperature of the REESS is stabilized such that the temperature varies by a gradient of less than 4 °C through 2 h. Where an automatic discharge interrupt function fails to operate, or if there is no such function, then the discharging shall be continued until the REESS is discharged to 25 per cent of its nominal voltage level;
- (d) Immediately after the termination of discharging, one standard charge followed by a standard discharge as described in Annex 9, Appendix 1 shall be conducted if it is not prohibited by the vehicle.

3.2.4. Discharge by external equipment (component-based test).

This procedure is applicable to component-based test:

- (a) All relevant main contactors shall be closed. The external charge-discharge shall be connected to the main terminals of the Tested-Device;

- (b) A discharge shall be performed with a stable current within the normal operating range as specified by the manufacturer;
- (c) The discharging shall be continued until the Tested-Device (automatically) terminates REESS discharge current or the temperature of the Tested-Device is stabilised such that the temperature varies by a gradient of less than 4 °C through 2 h. Where an automatic interrupt function fails to operate, or if there is no such function, then the discharging shall be continued until the Tested-Device is discharged to 25 per cent of its nominal voltage level;
- (d) Immediately after the termination of the discharging, one standard charge followed by a standard discharge as described in Annex 9, Appendix 1 shall be conducted if not inhibited by the Tested-Device.

~~At the beginning of the test, all relevant main contactors shall be closed.~~

~~A discharge shall be performed with at least 1/3 C rate but shall not exceed the maximum current within the normal operating range as specified by the manufacturer.~~

~~The discharging shall be continued until the tested device (automatically) interrupts or limits the discharging. Where an automatic interrupt function fails to operate, or if there is no such function then the discharging shall be continued until the tested device is discharged to 25 per cent of its nominal voltage level.~~

3.3. ~~Standard charge and observation period~~

~~Directly after termination of the discharging the tested device shall be charged with a standard charge as specified in Annex 8, Appendix 1 if not inhibited by the tested device. The test shall end with an observation period of 1 h at the ambient temperature conditions of the test environment."~~

Renumber (former) Annex 8I as Annex 9I, and amend to read:

"Annex 8I9I

Over-temperature protection

1. Purpose

The purpose of this test is to verify the performance of the protection measures of the REESS against internal overheating during the operation, ~~even under the failure of the cooling function if applicable~~. In the case that no specific protection measures are necessary to prevent the REESS from reaching an unsafe state due to internal over-temperature, this safe operation must be demonstrated.
2. ~~Installations~~
 - 2.1. ~~—————~~ The test may be conducted with a complete REESS according to paragraphs 3. and 4. or with a complete vehicle according to paragraphs 5. and 6.
3. Installation for test conducted using a complete REESS

- 3.1. **Ancillary systems that do not influence to the test results may be omitted from the Tested-Device. The test may be performed with a modified Tested-Device provided these modifications shall not influence the test results.**

~~The following test may be conducted with the complete REESS (maybe as a complete vehicle) or with related REESS subsystem(s), including the cells and their electrical connections. If the manufacturer chooses to test with related subsystem(s), the manufacturer shall demonstrate that the test result can reasonably represent the performance of the complete REESS with respect to its safety performance under the same conditions. The test may be performed with a modified tested device as agreed by the manufacturer and the Technical Service. These modifications shall not influence the test results.~~

- 23.2. Where a REESS is fitted with a cooling function and where the REESS will remain functional **in delivering its normal power** without a cooling function system being operational, the cooling system shall be deactivated for the test.

- 23.3. The temperature of the ~~tested device~~**Tested-Device** shall be continuously measured inside the casing in the proximity of the cells during the test in order to monitor the changes of the temperature. The on-board sensor, if existing may be used **with compatible tools to read the signal**. ~~The manufacturer and Technical Service shall agree on the location of the temperature sensor(s) used.~~

- 3.4. **The REESS shall be placed in a convective oven or climatic chamber. If necessary, for conduction the test, the REESS shall be connected to the rest of vehicle control system with extended cables. An external charge/discharge equipment may be connected under supervision by the vehicle manufacturer.**

4. **Test procedures for test conducted using a complete REESS.**

~~3.~~ **Procedures**

- 34.1. At the beginning of the test, all protection devices which affect the function of the ~~tested device~~**Tested-Device** and are relevant to the outcome of the test shall be operational, except for any system deactivation implemented in accordance with paragraph 23.2. above.

- 34.2. ~~During the test, t~~~~The tested device~~**Tested-Device** shall be continuously charged and discharged **by the external charge/discharge equipment** with a ~~steady~~ current that will increase the temperature of cells as rapidly as possible within the range of normal operation as defined by the manufacturer **until the end of the test.**

Alternatively, the charge and discharge may be conducted by vehicle driving operations on chassis dynamometer where the driving operation shall be determined through consultation with the manufacturer to achieve the conditions above.

- 34.3. ~~The tested device shall be placed in a convective oven or climatic chamber.~~ The temperature of the chamber or oven shall be gradually increased, **from 20 ± 10 °C or at higher temperature if requested by the manufacturer**, until it reaches the temperature determined in accordance with paragraph 34.3.1. or 34.3.2. below as applicable, and then maintained at a temperature that is equal to or higher than this, until the end of the test.

- 34.3.1. Where the REESS is equipped with protective measures against internal overheating, the temperature shall be increased to the temperature defined by the manufacturer as being the operational temperature threshold for such protective measures, to insure that the temperature of the ~~tested device~~ **Tested-Device** will increase as specified in paragraph 34.2. above.
- 34.3.2. Where the REESS is not equipped with any specific measures against internal over-heating, the temperature shall be increased to the maximum operational temperature specified by the manufacturer.
- 34.4. The end of test: The test will end when one of the followings is observed:
- (a) The ~~tested device~~ **Tested-Device** inhibits and/or limits the charge and/or discharge to prevent the temperature increase;
 - (b) The temperature of the ~~tested device~~ **Tested-Device** is stabilised, which means that the temperature varies by a gradient of less than 4 °C through 2 hours;
 - (c) Any failure of the acceptance criteria prescribed in paragraph 6.9.2.1. of the Regulation.
- 5. Installation for test conducted using a complete vehicle.**
- 5.1. **Based on information from the manufacturer, for a REESS fitted with a cooling function the cooling system shall be disabled or in a state of significantly reduced operation (for a REESS that will not operate if the cooling system is disabled) for the test.**
- 5.2. **The temperature of the REESS shall be continuously measured inside the casing in the proximity of the cells during the test in order to monitor the changes of the temperature using on-board sensors and compatible tools according to manufacturer provided information to read the signals.**
- 5.3. **The vehicle shall be placed in a climate control chamber set to a temperature between 40 °C to 45 °C for at least 6 hours.**
- 6. Test procedures for test conducted using a complete vehicle.**
- 6.1. **The vehicle shall be continuously charged and discharged in a manner that will increases the temperature of REESS cells as rapidly as possible within the range of normal operation as defined by the manufacturer until the end of the test.**
- The charge and discharge will be conducted by vehicle driving operations on chassis dynamometer where the driving operation shall be determined through consultation with the manufacturer to achieve the conditions above.**
- For a vehicle that can be charged by an external power supply, the charging may be conducted using an external power supply if more rapid temperature increase is expected.**
- 6.2. **The test will end when one of the followings is observed:**
- (a) **The vehicle terminates the charge and/or discharge;**
 - (b) **The temperature of the REESS is stabilised such that the temperature varies by a gradient of less than 4 °C through 2 hours;**

- (c) Any failure of the acceptance criteria prescribed in paragraph 6.9.2.1. of the Regulation;
- (d) 3 hours elapse from the time of starting the charge/discharge cycles in paragraph 6.1. "

Insert new Annex 9J, to read;

"Annex 9J

Over-current protection

1. Purpose

The purpose of this test is to verify the performance of the overcurrent protection during DC external charging to prevent the REESS from any severe events caused by excessive levels of charge current as specified by the manufacturer.

2. Test conditions:

- (a) The test shall be conducted at an ambient temperature of 20 ± 10 °C;
- (b) The SOC of REESS shall be adjusted around the middle of normal operating range by normal operation recommended by the manufacturer such as driving the vehicle or using an external charger. The accurate adjustment is not required as long as the normal operation of the REESS is enabled;
- (c) The overcurrent level (assuming failure of external DC electricity supply equipment) and maximum voltage (within normal range) that can be applied shall be determined, if necessary, through consultation with the manufacturer.

3. The overcurrent test shall be conducted in accordance with paragraph 4. or paragraph 5., as applicable and in accordance with manufacturer information.

4. Overcurrent during charging by external electricity supply.

This test procedure is applicable to vehicle-based test for vehicles that have the capability of charging by DC external electricity supply:

- (a) The DC charging vehicle inlet shall be used for connecting the external DC electricity supply equipment. The charge control communication of the external electricity supply equipment is altered or disabled to allow the overcurrent level determined through consultation with the manufacturer;
- (b) Charging of the REESS by the external DC electricity supply equipment shall be initiated to achieve the highest normal charge current specified by the manufacturer. The charge current is then increased over 5 s from the highest normal charge current to the overcurrent level determined in accordance with paragraph 2.(c) above. Charging is then continued at this overcurrent level;

- (c) The charging shall be terminated when the functionality of the vehicle's overcurrent protection terminates the REESS charge current or the temperature of the REESS is stabilised such that the temperature varies by a gradient of less than 4 °C through 2 hours;
- (d) Immediately after the termination of charging, one standard cycle as described in Annex 9, Appendix 1 shall be conducted, if it is not prohibited by the vehicle.

5. Overcurrent during charging using breakout harness.

This test procedure is applicable to REESS for vehicles that have the capability of charging by DC external electricity supply and for which the manufacturer provides information to connect a breakout harness to a location just outside the REESS that permits charging of the REESS:

- (a) The breakout harness is connected to the vehicle or REESS as specified by the manufacturer;
- (b) The external electricity supply equipment along with the overcurrent supply is connected to the breakout harness and charging of the REESS is initiated to achieve the highest normal charge current specified by the manufacturer;
- (c) The charge current is then increased over 5 seconds from the highest normal charge current to the overcurrent level determined in accordance with paragraph 2.(c) above. Charging is then continued at this overcurrent level;
- (d) The charging shall be terminated when the functionality of the vehicle's overcurrent protection terminates charging or the temperature of the Tested-Device is stabilised such that the temperature varies by a gradient of less than 4 °C through 2 h;
- (e) Immediately after the termination of charging, one standard cycle as described in Annex 9, Appendix 1 shall be conducted, if it is not prohibited by the vehicle.

6. The test shall end with an observation period of 1 h at the ambient temperature conditions of the test environment."

II. Justification

1. The technical provisions of global technical regulation No.20 (GTR20) are adopted for UN Regulation No.100.
 2. The scope of Part I should be clarified as it covers the vehicles not operating on high voltage, but equipped with a REESS (which is subject to the requirements of Part II). For vehicles having electric power train operating on low voltage, the requirements of Part I except for paragraph 5.1. shall apply.
 3. GTR20 provides additional requirements related to warning of REESS. These requirements are separated into Part I for vehicle level with respect to indication and into Part II for REESS level with respect to the detection and signalling.
 4. In GTR20, the compliance alternative of installation of isolation resistance monitoring system as a measure for protection against water effect is an option for Contracting Parties to the UN98 Agreement. Since such measure is technically valid, it should be accepted for this UN Regulation.
 5. The amendment considered in ECE/TRANS/WP.29/GRSP/2019/17 is merged into this document. Although this requirement differs that of GTR20, the safety concern raised by the NL should be addressed before having discussion for GTR20. The title of paragraph 5.3. is modified from “functional safety” to “preventing accidental or unintended vehicle movement” in order to avoid confusion.
 6. GTR20 provide REESS post-crash requirements but does not specify the crash configuration. The crash configurations of current version of UN Regulation No.100, namely frontal impact (UNR94 or UNR137) and lateral impact (UNR95) are maintained. With the relevant amendments to such crash regulations, the approval of such UNRs are regarded as the alternative to the post-crash requirements in this Regulation.
 7. Overcurrent protection is one of the new requirements established in GTR20. However, the validity of this requirement will be reconsidered in EVS-GTR phase 2 and therefore this requirement is kept in square bracket until the 67th session of GRSP.
 8. The administrative provisions of this Regulation are simplified by referring to the relevant Schedule of the Revision 3 of the 58 Agreement.
 9. This new series of amendments contains several new or modified test requirement and therefore reasonable period of 2-3 years should be Since the provisions of current version of UN Regulation No.100 are reasonably functioning, the alignment of GTR20 need not to be introduced for existing vehicles.
-