

## **Committee of Experts on the Transport of Dangerous Goods and on the Globally Harmonized System of Classification and Labelling of Chemicals**

27 November 2019

### **Sub-Committee of Experts on the Transport of Dangerous Goods**

#### **Fifty-sixth session**

Geneva, 2-11 December 2019

Item 4 (f) of the provisional agenda

**Electric storage systems: miscellaneous**

## **Classification of vanadium redox flow battery**

### **Transmitted by the expert from China**

### **Background**

1. At the forty-third and forty-fourth sessions of the Sub-Committee Austria presented two documents INF.22 (43<sup>rd</sup> session) and ST/SG/AC.10/C.3/2013/60 regarding flow batteries. The expert from Austria asked a question concerning the classification of redox flow batteries – possibly as UN No. 2794 or 3363.
2. According to the report of the Sub-Committee in its forty-fourth session, the Sub-Committee noted, however, that there are various kinds of electrodes and electrolytes and there seemed to be no easy answer to the question; it was probably best to address it on a case-by-case basis. The Sub-Committee agreed to return to the question at a later date provided that a delegation submitted another proposal.

### **Introduction**

3. The vanadium redox flow battery is one of flow batteries, which is widely used as emergency power supply, renewable energy power generation such as wind energy and solar energy, and plays the role of cutting peaks, filling the valley, balancing the load and improving the power quality.
4. Vanadium redox flow battery is mainly composed of a stack, electrolyte circulating pumps, a cooling fan, two high-density polyethylene (HDPE) electrolyte storage tanks, a battery control system, related pipeline systems, electrolyte and a steel outer container, and the basic structure is shown in Figure 1.

Figure 1: basic structure of vanadium redox flow battery

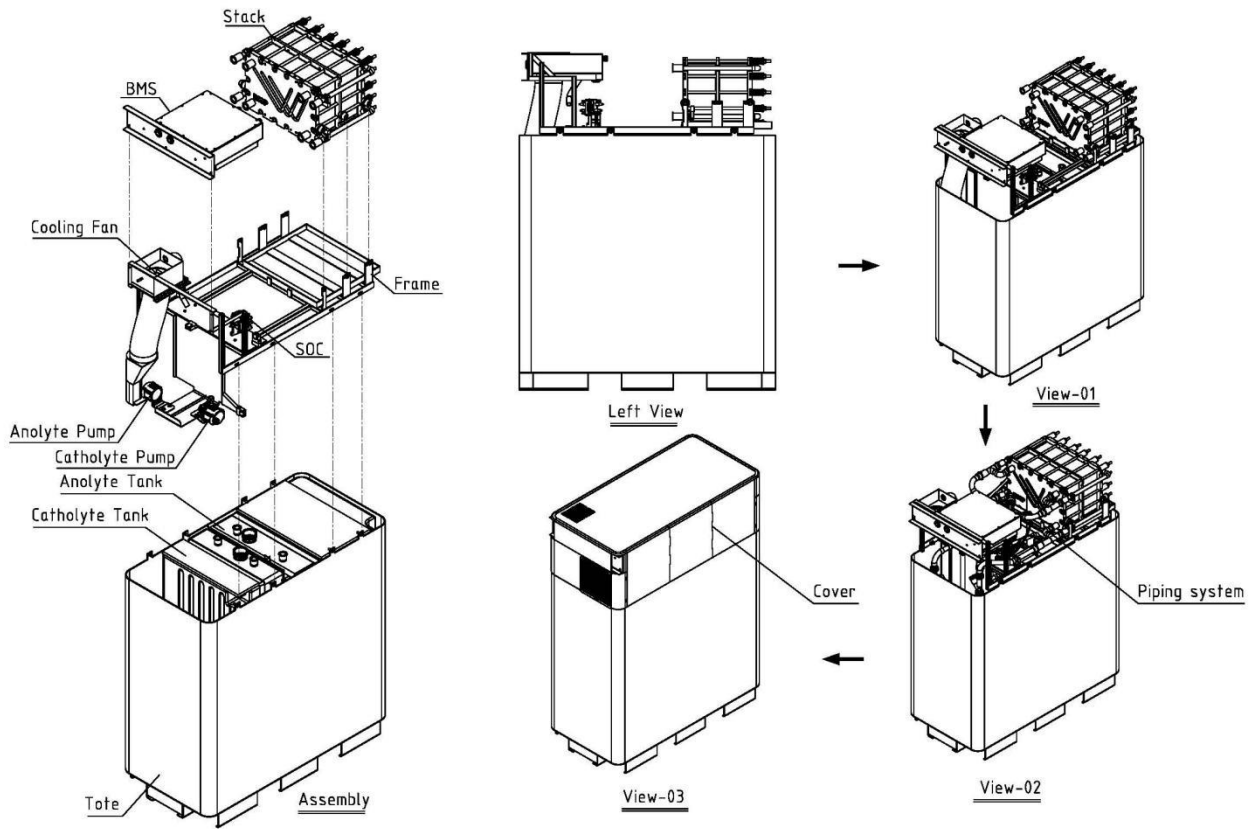

5. The electrolyte of vanadium redox flow battery is an acid vanadium ion electrolyte, which is a kind of acidic corrosive liquid normally and belongs to class 8. Although stored separately in positive electrolyte storage tank and negative electrolyte storage tank, the electrolyte is the same material in two tanks.

6. The weight of vanadium redox flow battery is at least hundreds of kilograms, the construction and design of its structure could afford adequate protection. As shown in Figure 2, the product designed for mechanical handling can meet the requirements of Composite Intermediate Bulk Container. Therefore, vanadium redox flow battery can be transported without packing. The outer packaging is not required.

Figure 2: the construction and design of its structure

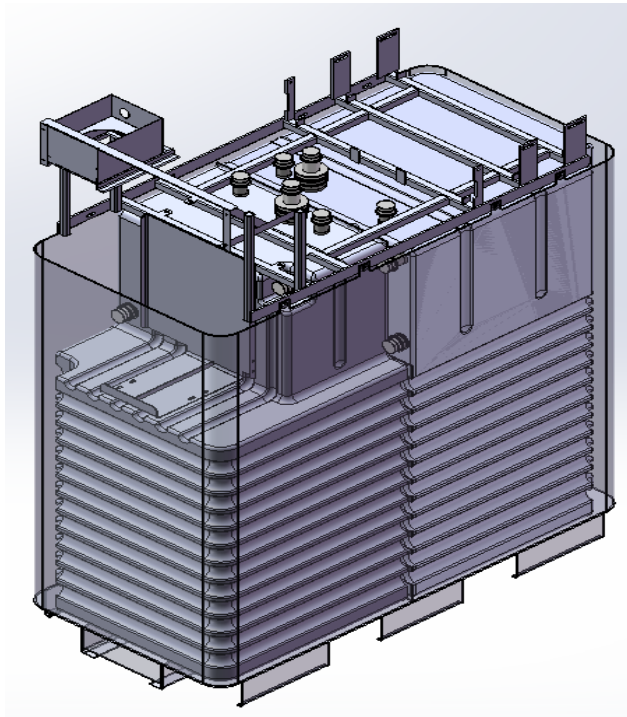

7. The whole system of vanadium redox flow battery does not run during transportation and is not charged. Since the deep discharge of vanadium redox flow battery does not influence its lifetime, so the battery can be transported without charge. The protection of preventing short-circuiting is not needed in this instance. During transportation, the appearance of vanadium redox flow battery is more like a machinery or apparatus, except that the quantity of dangerous goods in battery is very large.

## Analysis

8. In Dangerous Goods List of Model Regulations, UN 2794 applies to BATTERIES, WET, FILLED WITH ACID, electric storage. Obviously, vanadium redox flow battery is different from traditional battery. In any case, the state of charge of UN 2794, whatever new or used, cannot be 0%. But the state of charge of vanadium redox flow battery is 0%, because the battery is not charged, so the protection against short circuit is not necessary. The packing instruction P801 of UN 2794 is too strict for vanadium redox flow battery, the additional provisions in P801 is not applicable to it. The weight of electrolyte in vanadium redox flow battery is at least hundreds of kilograms, so the limited quantities and excepted quantities of UN 2794 is not applicable to it. Therefore, the requirements of UN 2794 are not suitable to transport vanadium redox flow battery.

9. According to special provision 301, UN 3363 only applies to machinery or apparatus containing dangerous goods as a residue or an integral element of the machinery or apparatus, and the quantity of dangerous goods in machinery or apparatus shall not exceed the quantity specified in Column 7a of the Dangerous Goods List of chapter 3.2 for each item of dangerous goods contained. Apparently, UN 3363 is applied to machinery or apparatus containing small quantity of dangerous goods. The net weight of electrolyte in vanadium redox flow battery is usually hundreds of kilograms. Therefore, it is not appropriate to transport vanadium redox flow battery as UN 3363.

10. In Dangerous Goods List of Model Regulations, UN 3547 applies to ARTICLES CONTAINING CORROSIVE SUBSTANCE, N.O.S. There are two Packing instructions P006 and LP03 in UN3547. According to P006, articles may be transported unpackaged or on pallets when the dangerous goods are afforded equivalent protection by the article in which they are contained. In LP03, the instruction does not allow articles to be transported unpackaged or on pallets. In section 1.2.1 of Model Regulations, large packaging means packaging which exceed 400 kg net mass or 450 litre capacity but has a volume of not more than 3 m<sup>3</sup>. According to section 6.1.1, the “P” packing instructions apply to packages whose net mass do not exceed 400 kg or packages for liquids with a capacity not exceeding 450 litre. There is confusion that if the net mass of a packaging exceeds 450 L/400 kg, is it correct that the article be transported unpackaged or on pallets in accordance with P006? The net weight of electrolyte in vanadium redox flow battery usually exceeds 450 litre. Is it possible to transport unpackaged vanadium redox flow battery as UN 3547?

## Conclusion

11. In order to consider the new type of vanadium redox flow battery and lay down its suitable transport condition, it is proposed to add a special provision to UN 2794 or amend the instruction of LP03.

## Proposal

12. Option 1:

Add a special provision SPXXX to UN 2794, as follows:

XXX This provision applies to vanadium redox flow battery which electrolyte belongs to class 8 other than any other classes. If the battery is not charged, the protection against short circuit is not needed. If the battery is constructed and designed so that the receptacles containing the dangerous goods are afforded adequate protection, an outer packaging is not required. The stacking on the battery is forbidden.

or

13. Option2:

Add a sentence in the end of LP03, as follows:

LP03	PACKING INSTRUCTION	LP03
	This instruction applies to UN Nos. 3537, 3538, 3540, 3541, 3546, 3547 and 3548.	
	(1) The following large packagings are authorized, provided that the general provisions of 4.1.1 and 4.1.3 are met: Rigid large packagings conforming to the packing group II performance level made of: steel (50A); aluminium (50B); metal other than steel or aluminium (50N); rigid plastics (50H); natural wood (50C); plywood (50D);	

reconstituted wood (50F);

rigid fiberboard (50G).

(2) Additionally, the following conditions shall be met:

(a) Receptacles within articles containing liquids or solids shall be constructed of suitable materials and secured in the article in such a way that, under normal conditions of transport, they cannot break, be punctured or leak their contents into the article itself or the outer packaging;

(b) Receptacles containing liquids with closures shall be packed with their closures correctly oriented. The receptacles shall in addition conform to the internal pressure test provisions of 6.1.5.5;

(c) Receptacles that are liable to break or be punctured easily, such as those made of glass, porcelain or stoneware or of certain plastics materials shall be properly secured. Any leakage of the contents shall not substantially impair the protective properties of the article or of the outer packaging;

(d) Receptacles within articles containing gases shall meet the requirements of Section 4.1.6 and Chapter 6.2 as appropriate or be capable of providing an equivalent level of protection as packing instructions P200 or P208; and

(e) Where there is no receptacle within the article, the article shall fully enclose the dangerous substances and prevent their release under normal conditions of transport.

(3) Articles shall be packed to prevent movement and inadvertent operation during normal conditions of transport.

(4) Articles may be transported unpackaged or on pallets when the dangerous goods are afforded equivalent protection to that provided by chapter 6.6 by the article in which they are contained.