

**Committee of Experts on the Transport of Dangerous Goods
and on the Globally Harmonized System of Classification
and Labelling of Chemicals**

7 September 2018

**Sub-Committee of Experts on the
Transport of Dangerous Goods**

Fifty-fourth session

Geneva, 26 November-5 December 2018

Item 7 (d) of the provisional agenda

**Issues relating to the Globally Harmonized System
of Classification and Labelling of Chemicals: use of
the Manual of Tests and Criteria in the context of
the GHS**

**Sub-Committee of Experts on the Globally Harmonized
System of Classification and Labelling of Chemicals**

Thirty-sixth session

Geneva, 5-7 July 2018

Item 3 (a) of the provisional agenda

**Classification criteria and related hazard
communication: Work of the Sub-Committee of
Experts on the Transport of Dangerous Goods (TDG)
on matters of interest to the GHS Sub-Committee**

**Use of the Manual of Tests and Criteria in the context of the
GHS**

**Transmitted by the Chairman of the Working Group on Explosives of
the Sub-Committee of Experts on the Transport of Dangerous Goods
(TDG Sub-Committee) on behalf of the Working Group**

1. Document ST/SG/AC.10/C.3/2018/88–ST/SG/AC.10/C.4/2018/26 contains the list of amendments to section 28 of the Manual of Tests and Criteria to include the determination of the SAPT, recommended for adoption by the TDG and GHS sub-committees.
2. This document contains the text of Part II section 28 of the sixth revised edition of the Manual of Tests and Criteria, as amended by ST/SG/AC.10/C.3/2018/88–ST/SG/AC.10/C.4/2018/26. All the proposed amendments are indicated: inserted text is shown in blue (**inserted**); deleted text is shown in red, strikethrough (**deleted**).

SECTION 28

TEST SERIES H

28.1 Introduction

This test series contains test methods for the determination of the self-accelerating decomposition temperature (SADT) and the self-accelerating polymerization temperature (SAPT). The SADT is defined as the lowest temperature at which self-accelerating decomposition may occur with a substance in the packaging as used in transport. The SAPT is defined as the lowest temperature at which self-accelerating polymerization may occur with a substance in the packaging. The SADT and SAPT are ~~is-a~~ measures of the combined effect of the ambient temperature, ~~decomposition~~ reaction kinetics, package size and the heat transfer properties of the substance and its packaging. To assist in interpreting the results, models can be used in which the main resistance to heat flow is:

- (a) At the boundary i.e. packaging (Semenov model);
- (b) Within the substance (Frank-Kamenetskii model); or
- (c) A combination of these (Thomas model).

The text should be used in conjunction with the temperature control requirements given in sub-section 2.5.3.4 of the Model Regulations.

References: *N.N. Semenov, Z. Physik, 48, 1928, 571.*
D.A. Frank-Kamenetskii, Zhur. Fiz. Khim., 13, 1939, 738.
P.H. Thomas, Trans. Faraday Soc., 54, 1958, 60.

28.2 Test methods

28.2.1 Test series H comprises tests and criteria concerning the thermal stability of substances at transport temperatures or concerning the determination of whether a substance meets the definition of a self-reactive substance or a polymerizing substance.

28.2.2 Each test involves either storage at a fixed external temperature and observation of any reaction initiated or storage under near adiabatic conditions and measurement of the rate of heat generation versus temperature. The test methods included in test series H are given in Table 28.1. Each of the methods listed is applicable to solids, liquids, pastes and dispersions.

Table 28.1: TEST METHODS FOR TEST SERIES H

Test code	Name of test	Section
H.1	United States SADT test ^a	28.4.1
H.2	Adiabatic storage test (AST) ^b	28.4.2
H.3	Isothermal storage test (IST)	28.4.3
H.4	Heat accumulation storage test ^c	28.4.4

^a Recommended test for substances transported in packagings.

^b Recommended test for substances transported in packagings, IBCs or tanks.

^c Recommended test for substances transported in packagings, IBCs or small tanks.

The list of tests is not exhaustive; other tests may be used provided that they give the correct SADT or SAPT of the substance as packaged for transport.

28.2.3 When temperature control is necessary (see Table 28.2) (~~SADT \leq 50 °C for organic peroxides, SADT \leq 55 °C for self-reactive substances~~), the control and emergency temperatures ~~may~~ should be derived from the SADT or SAPT using Table 28.23.

Table 28.2: CRITERIA FOR TEMPERATURE CONTROL

Type of substance	Criterion for temperature control
Self-reactive substance	SADT \leq 55 °C
Organic peroxide Type B and C	SADT \leq 50 °C
Organic peroxide Type D showing medium effect when heated under confinement ¹	SADT \leq 50 °C
Organic peroxides Type D showing low or no effect when heated under confinement ¹	SADT \leq 45 °C
Organic peroxides Type E and F	SADT \leq 45 °C
Polymerizing substance in packaging or IBC	SAPT \leq 50 °C
Polymerizing substance in portable tank	SAPT \leq 45 °C

¹ As determined by test series E as prescribed in this Manual of Tests and Criteria, Part II

Table 28.23: DERIVATION OF CONTROL AND EMERGENCY TEMPERATURES

Type of receptacle	SADT/SAPT ^a	Control temperature	Emergency temperature
Single packagings and IBCs	\leq 20 °C	20 °C SADT/SAPT	below 10 °C SADT/SAPT
	over 20 °C to 35 °C	15 °C SADT/SAPT	below 10 °C SADT/SAPT
	over 35 °C	10 °C SADT/SAPT	below 5 °C SADT/SAPT
Portable tanks	\leq 45 \leq 50 °C	10 °C SADT/SAPT	below 5 °C SADT/SAPT

^a i.e. the SADT/SAPT of the substance as packaged for transport.

28.2.4 If a substance is being tested to determine whether it is a self-reactive substance ~~of Division 4.1~~, a test of series H, or a suitable alternative test, should be performed to determine if its SADT would be less than or equal to 75 °C when transported in a 50 kg package.

28.2.5 If a substance is being tested to determine whether it is a polymerizing substance, a test of series H, or a suitable alternative test, should be performed to determine if its SAPT would be less than or equal to 75 °C in its packaging, IBC or portable tank.

28.2.56 The results obtained for the largest commercial package are applicable to smaller packages of similar construction and material provided that the heat transfer per unit mass is no smaller than from the larger package.

28.3 Test conditions

28.3.1 For organic peroxides and self-reactive substances the preliminary procedure (see section 20.3) should be performed and the effect of heating under confinement (test series E) determined before performing SADT tests. *Safety precautions should be taken which allow for the possibility of catastrophic failure of the test vessel and for the hazards arising from the ignition of secondary fuel-air mixtures and the evolution of toxic decomposition products. Substances liable to detonate should only be tested with special precautions.*

28.3.2 The test selected should be conducted in a manner which is representative, both in size and material, of the package to be transported. For transport in metal packagings, IBCs or tanks, it may be necessary to include a representative amount of the metal in the sample tested i.e. representative of both the metal(s) and the area of contact.

28.3.3 *Extra care should be taken when handling samples which have been tested since changes may have occurred rendering the substance more unstable and more sensitive. Tested samples should be destroyed as soon as possible after the test.*

28.3.4 Samples which have been tested at a particular temperature and are apparently unreacted may be used again, for screening purposes only, provided extra care is taken. Fresh samples should be used for the actual determination of the SADT or SAPT.

28.3.5 If the complete package is not tested, the heat loss data used for the determination of the SADT or SAPT should be representative of the package, IBC or tank offered for transport. The heat loss per unit of mass of the package, IBC or tank may be determined by calculation (taking account of the quantity of substance, dimensions of the package, heat transfer in the substance and the heat transfer through the packaging to the environment) or by measuring the half-time of cooling of the package filled with the substance or another substance having similar physical properties. The heat loss per unit mass, L (W/kg.K), can be calculated from the half-time of cooling, $t_{1/2}$ (s), and the specific heat, C_p (J/kg.K), of the substance using the formula:

$$L = \ln 2 \times \left(\frac{C_p}{t_{1/2}} \right)$$

28.3.6 The half-time of cooling can be determined by measuring the period of time in which the temperature difference between the sample and surroundings is decreased by a factor of 2. For example, for liquids, the packaging may be filled with dibutyl phthalate or dimethyl phthalate and this heated to about 80 °C. Water should not be used as erratic results may be obtained through evaporation / condensation. The temperature drop is measured at the centre of the package over the temperature range which includes the expected SADT or SAPT. For scaling, it may be necessary continuously to monitor the temperature of the substance and surroundings and then use linear regression to obtain the coefficients of the equation:

$$\ln \{T - T_a\} = c_o + c \times t$$

where: T = substance temperature (°C);
 T_a = ambient temperature (°C);
 c_o = $\ln\{\text{Initial substance temperature} - \text{initial ambient temperature}\}$; and
 c = L/C_p ;
 t = time (s).

28.3.7 Examples of the heat loss characteristics of some typical packages are given in Table 28.3. The actual value obtained will depend on the shape, wall thickness, surface coating etc. of the packaging.

Table 28.3: HEAT LOSS PER UNIT MASS FROM PACKAGES, IBCs AND TANKS

Type of receptacle	Normal capacity (litres)	Filling	Heat loss per unit mass (L) (mW/K.kg)
<i>For liquids:</i>			
1A1	50	47.5 kg DMP ^a	63
1H1	50	47.5 kg DMP ^a	94
1H1	200	200 kg water	56
3H1 (black)	60	47.5 kg DMP ^a	105
6HG2	30	35.0 kg DMP ^a	69
IBC 31 HA1	500	500 kg water	51
Tank	3 400	3 400 kg water	18 ^b
Tank container (insulated)	20 000	14 150 kg isododecane	1.7
<i>For solids:</i>			
1G	38	28.0 kg DCHP ^c	35
1G	50	37.0 kg DCHP ^c	29
1G	110	85.0 kg DCHP ^c	22
4G	50	32.0 kg DCHP ^c	27

^a DMP = dimethyl phthalate.

^b Calculated using a heat transfer coefficient of 5 W/m².K.

^c Dicyclohexyl phthalate (solid).

28.4 Series H test prescriptions

28.4.1 *Test H.1: United States SADT test*

28.4.1.1 *Introduction*

This method determines the minimum constant temperature air environment at which self-accelerating~~auto-accelerative~~ decomposition occurs for a substance in a specific package. Packages of up to 2250 litres may be tested by this method. An indication of the explosion hazard from the decomposition or polymerization reaction can also be obtained.

28.4.1.2 *Apparatus and materials*

28.4.1.2.1 The test substance and packaging should be representative of that intended for commercial use. The packaging forms an essential part of the test.

28.4.1.2.2 The apparatus consists of a test chamber in which the air surrounding the package under test can be maintained at a constant temperature for a period of at least ten days.

28.4.1.2.3 The test chamber should be constructed such that:

- (a) It is well insulated;
- (b) Thermostatically controlled air circulation is provided so as to maintain a uniform air temperature within ± 2 °C of the desired temperature; and
- (c) The minimum separation distance from the package to the wall is 100 mm.

Any type of oven may be used provided that it is capable of meeting the temperature control requirements and will not ignite any decomposition products. Examples of a suitable small-package and large-package oven are given in 28.4.1.2.4 and 28.4.1.2.5 respectively.

28.4.1.2.4 A small-package oven may be constructed from an open head 220 litre steel drum. This will readily accommodate packages of up to 25 litres capacity. Construction details are shown in Figure 28.4.1.1. Larger packages may be tested as long as a 100 mm clearance between the package and the oven wall is maintained.

28.4.1.2.5 An expendable large-package oven may be made from 50 mm × 100 mm lumber formed into a cubic frame 1.2 m on each side, which is lined inside and out with 6 mm thick waterproof plywood and insulated all around with 100 mm fibreglass insulation. Construction details are shown in Figure 28.4.1.2. The frame should be hinged on one side to permit loading and unloading of test drums. The floor should be provided with 50 mm × 100 mm lumber on edge, spaced 200 mm on centres to keep the test container off the floor and allow free air circulation around the package. Cleats should run normal to the door to permit a fork-lift to move the drums. A circulating fan should be located on the side opposite the door. The air flow should be from the upper corner of oven to the fan discharge at the diagonally opposite lower corner. An electric heater of 2.5 kW is suitable for heating the air. Thermocouples should be placed in the air intake and outflow ducts as well as the top, middle and bottom of the oven. For substances with an SADT or SPT below ambient temperature, the test should be performed in a cooling chamber or solid carbon dioxide should be used for cooling the oven.

28.4.1.2.6 The package should be equipped with a thermowell which positions the thermocouple at the package mid-point. The thermowell may be constructed of glass, stainless steel or other suitable material but should be introduced in a manner which does not reduce package strength or venting capability.

28.4.1.2.7 Continuous temperature-measuring and recording equipment, which is protected from fire and explosion hazards, is required.

28.4.1.2.8 ***The tests should be performed in an area which provides adequate protection from fire and explosion hazards, and from toxic fumes. A safety distance, e.g. 90 m, from public roads and occupied buildings is recommended. If there may be toxic fumes, longer safety distances may be required.***

28.4.1.3 *Procedure*

28.4.1.3.1 The package is weighed. A thermocouple is inserted in the package to be tested such that the temperature in the centre of the sample can be monitored. If the required oven temperature is below ambient, the oven is switched on and the inside of the oven cooled to the desired temperature before placing the package in the oven. If the required oven temperature is at or above ambient temperature, the package is inserted in the oven at ambient temperature and the oven then switched on. There should be a minimum clearance of 100 mm between the package and the sides of the oven.

28.4.1.3.2 The sample is heated and the temperature of the sample and test chamber continuously monitored. The time is noted at which the sample temperature reaches a temperature 2 °C below the test chamber temperature. The test is then continued for a further seven days or until the sample temperature rises to 6 °C or more above the test chamber temperature if this occurs sooner. Note the time taken for the sample to rise from the 2 °C below the test chamber temperature to its maximum temperature.

28.4.1.3.3 When the test is completed, cool the sample and remove it from the test chamber. Note the variation of temperature with time. If the package remains intact, note the percentage mass loss and determine any changes in composition. Dispose of the sample as soon as possible.

28.4.1.3.4 If the temperature of the sample does not exceed the oven temperature by 6 °C or more then repeat the test with a new sample in an oven at a 5 °C higher temperature. The ~~self-accelerating decomposition temperature (SADT or SAPT)~~ is defined as the lowest oven temperature at which the sample temperature exceeds the oven temperature by 6 °C or more. If the substance is being tested to determine if temperature control is necessary, perform sufficient tests to determine the SADT or SAPT to the nearest 5 °C or to determine if the SADT or SAPT is greater than or equal to 60 °C. If the substance is being tested to determine if it meets the SADT criterion for a self-reactive substance, perform sufficient tests to determine if the SADT for a 50 kg package is 75 °C or less. *If the substance is being tested to determine if it meets the SAPT criterion for a polymerizing substance, perform sufficient tests to determine if the SAPT in the packaging as used is 75 °C or less.*

28.4.1.4 *Test criteria and method of assessing results*

28.4.1.4.1 The SADT or SAPT is reported as the lowest temperature at which the sample exceeds the oven temperature by 6 °C or more. If the sample temperature does not exceed the oven temperature by 6 °C or more in any test, the SADT or SAPT is recorded as being greater than the highest oven temperature used.

28.4.1.5 *Examples of results*

Substance	Sample mass (kg)	Packaging	SADT/SAPT (°C)
tert-Amyl peroxybenzoate	18.2	6HG2, 22.8 litres	65
tert-Butyl peroxyacetate (60%)	7.2	6HG2, 22.8 litres	75
Dibenzoyl peroxide	0.45	1G	70
Di-(4-tert-butylcyclohexyl) peroxydicarbonate	43	1G	40
2,5-Diethoxy-4-morpholinobenzene-diazonium zinc chloride (66%)	30	1G, 50 litres	50
2-(N-ethoxycarbonyl-N-phenylamino)-3-methoxy-4-(N-methyl-N-cyclohexyl-amino)benzenediazonium zinc chloride (62 %)	10	6HG1, 25 litres	50

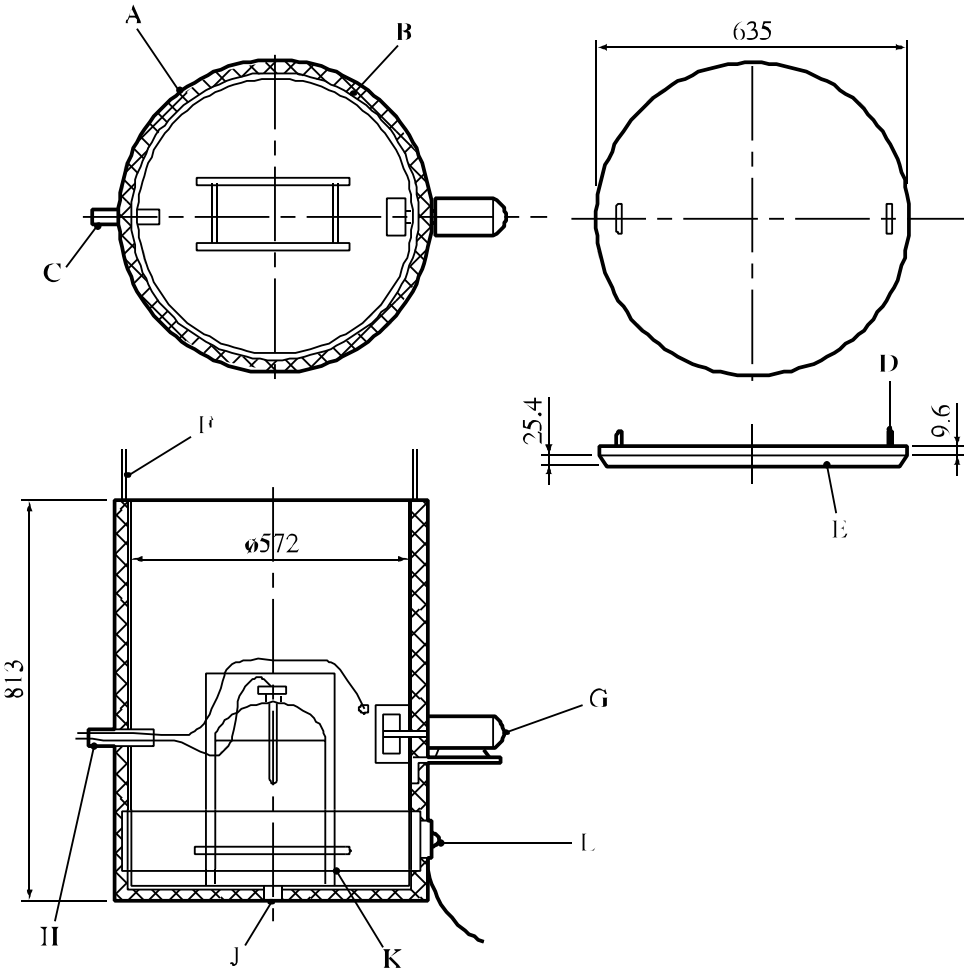

-
- | | |
|-------------------------------|------------------------------------|
| (A) Insulation 25 mm thick | (B) 220 litres open top drum |
| (C) 19 mm pipe | (D) 9.6 mm eye bolt in steel cover |
| (E) Insulation on steel cover | (F) 3 mm control cable |
| (G) Fan | (H) Thermocouples and controls |
| (J) Drain | (K) 25 mm angle stand |
| (L) 2 kW drum heater | |
-

Figure 28.4.1.1: SMALL PACKAGE OVEN

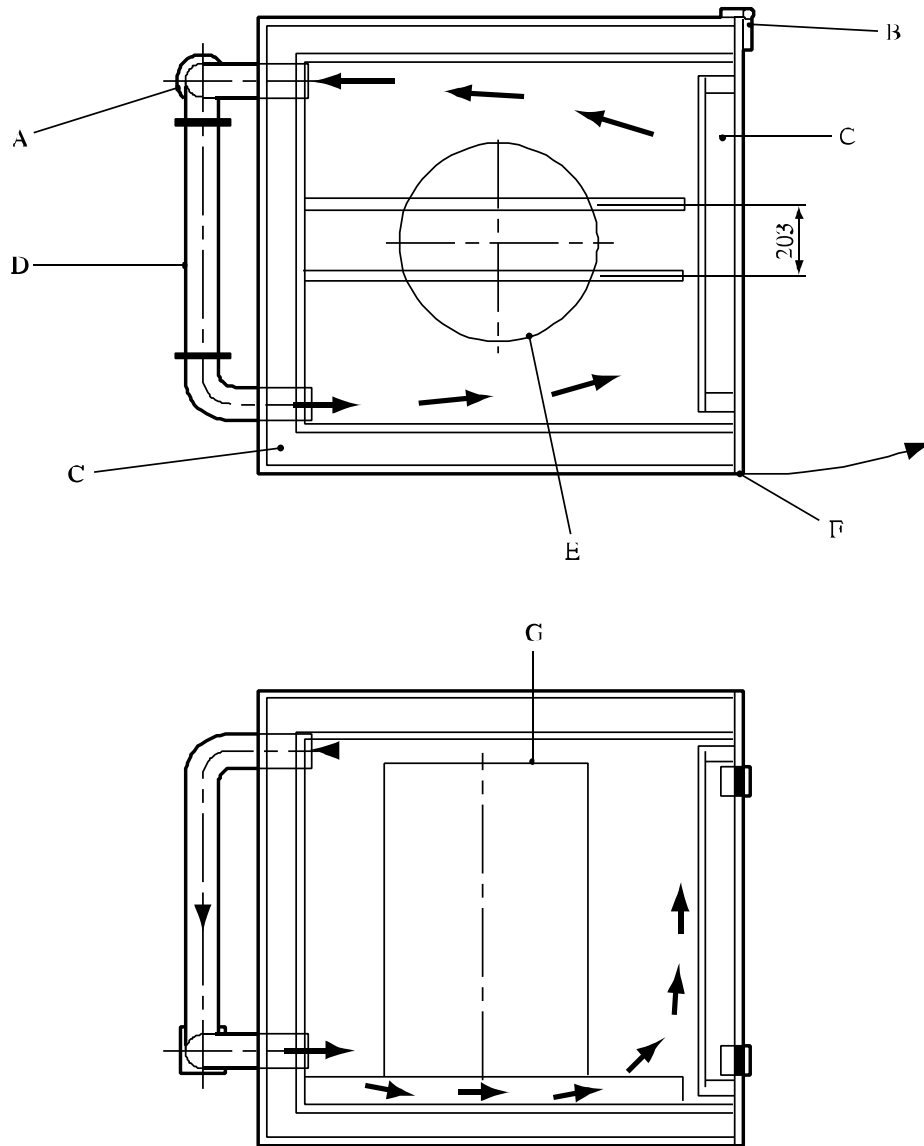

-
- | | |
|---------------------------------|----------------|
| (A) Fan | (B) Hinges (2) |
| (C) Insulation | (D) Heater |
| (E) Drum | (F) Latch |
| (G) Drum (e.g. 0.58 m x 0.89 m) | |
-

Figure 28.4.1.2: LARGE PACKAGE OVEN (top view and side view)

28.4.2 *Test H.2: Adiabatic storage test*

28.4.2.1 *Introduction*

28.4.2.1.1 This test method determines the rate of heat generation produced by a reacting substance as a function of temperature. The heat generation parameters obtained are used with the heat loss data relating to the package to determine the SADT *or* SAPT of a substance in its packaging. The method is appropriate for every type of packaging, including IBCs and tanks.

28.4.2.1.2 Measurements can be performed in the temperature range from -20 °C to 220 °C. The smallest temperature rise that can be detected corresponds to a rate of heat generation of 15 mW/kg. The upper limit is determined by the capacity of the cooling system to safely cool the substance (up to 500 W/kg if water is used as the coolant). Although the test is not perfectly adiabatic, the heat losses are less than 10 mW. The maximum error is 30% at 15 mW/kg and 10% from 100 mW/kg to 10 W/kg.

28.4.2.1.3 If the cooling system is activated at a stage where the rate of heat generation exceeds the cooling capacity, an explosion may occur. ***The test site should therefore be carefully selected to reduce to a minimum the possible hazards from an explosion and of a possible subsequent gas explosion of the decomposition products (secondary explosion).***

28.4.2.2 *Apparatus and materials*

28.4.2.2.1 The apparatus consists of a glass Dewar vessel (1.0 or 1.5 litre) to contain the sample, an insulated oven with a differential control system to keep the temperature in the oven to within 0.1 °C of the sample temperature and an inert lid for the Dewar vessel. In special cases, sample holders of other construction materials may have to be used. An inert heating coil and cooling tube pass through the lid into the sample. Pressure build-up in the Dewar vessel is prevented by a 2 m long PTFE capillary tube which passes through the insulated lid. A constant power heating unit is used for internal heating of the substance to a pre-set temperature or for calibration. Internal heating and cooling may be stopped or started automatically at pre-set temperatures. In addition to the cooling system, a secondary safety device is fitted which disconnects the power supply to the oven at a pre-set temperature. A schematic drawing of the AST is given in Figure 28.4.2.1.

28.4.2.2.2 The temperature of the substance is measured at its centre by means of thermocouples or platinum resistance sensors placed in a steel or glass tube. The temperature of the surrounding air is measured at the same height as the sample temperature, also with thermocouples or platinum resistance sensors. Continuous temperature measuring and recording equipment is required to monitor the temperature of substance and the air in the oven. This equipment should be protected from fire and explosion. For substances with an SADT *or* SAPT below ambient temperature, the test should be performed in a cooling chamber or solid carbon dioxide should be used for cooling the oven.

28.4.2.3 *Procedure*

28.4.2.3.1 Calibration procedure

The calibration procedure is as follows:

- (a) Fill the Dewar vessel with sodium chloride, dibutyl phthalate or with a suitable oil and place it in the vessel holder of the AST oven;
- (b) Heat the sample in 20 °C steps using the internal heating system at a known power rating, e.g. 0.333 or 1.000 W, and determine the heat losses at 40 °C, 60 °C, 80 °C and 100 °C;
- (c) Use the data to determine the heat capacity of the Dewar vessel using the method given in 28.4.2.4.

28.4.2.3.2 Test procedure

The test procedure is as follows:

- (a) Fill the Dewar vessel with the weighed sample, including a representative amount of packaging material (if metal), and place it in the vessel holder of the AST oven;
- (b) Start the temperature monitoring and then increase the sample temperature using the internal heater to a pre-set temperature at which detectable self-heating may occur. The specific heat of the substance can be calculated from the temperature rise, heating time and heating power;
- (c) Stop the internal heating and monitor the temperature. If no temperature rise due to self-heating is observed within 24 hours, increase the temperature by 5 °C. Repeat this procedure until self-heating is detected;
- (d) When self-heating is detected, the sample is allowed to heat up under adiabatic conditions to a pre-set temperature where the rate of heat generation is less than the cooling capacity, upon which the cooling system is activated;
- (e) On cooling, determine the loss in mass, if any, and determine the change in composition (if desired).

28.4.2.4 *Test criteria and method of assessing results*

28.4.2.4.1 Calculate the rate of temperature drop, A (°C/h), of the Dewar vessel at the different temperatures used in the calibration procedure. Plot a graph through these values in order to allow determination of the rate of temperature drop at any temperature.

28.4.2.4.2 Calculate the heat capacity, H (J/°C), of the Dewar vessel using the formula:

$$H = \frac{3600 \times E_1}{A + B} - (M_1 \times Cp_1)$$

where: E_1 = power applied to the internal heater (W)
A = rate of temperature drop at the temperature of calculation (°C/h)
B = slope of the curve on internal heating (calibration substance) at the temperature of calculation (°C/h)
 M_1 = mass of calibration substance (kg)
 Cp_1 = specific heat of calibration substance (J/kg.°C)

28.4.2.4.3 Determine the heat loss, K (W), using:

$$K = \frac{A \times (H + M_1 \times Cp_1)}{3600}$$

at each desired temperature and draw a graph through these values.

28.4.2.4.4 Calculate the specific heat, Cp_2 (J/kg.°C) of the substance using:

$$Cp_2 = \frac{3600 \times (E_2 + K)}{C \times M_2} - \frac{H}{M_2}$$

where: E_2 = power applied to the internal heater (W)
 C = slope of the curve on internal heating (sample) at the temperature of calculation (°C/h)
 M_2 = mass of sample (kg)

28.4.2.4.5 Calculate the heat generation, Q_T (W/kg), of the substance at intervals of 5 °C using the following formula for each temperature:

$$Q_T = \frac{(M_2 \times Cp_2 + H) \times \frac{D}{3600} - K}{M_2}$$

where: D = slope of the curve during the self-heating at the temperature of calculation (°C/h)

28.4.2.4.6 Plot the calculated rates of heat generation per unit of mass as a function of the temperature in a graph with linear scales and draw the best-fit curve through the plotted points. Determine the heat losses per unit of mass, L (W/kg.°C) of the specific package, IBC or tank (see 28.3.5). Draw a straight line of gradient L tangential to the heat generation curve. The intersection of the straight line and the abscissa is the critical ambient temperature i.e. the highest temperature at which the substance as packaged does not show self-accelerating decomposition. The SADT or SAPT is the critical ambient temperature (°C) rounded to the next higher multiple of 5 °C. An example is given in Figure 28.4.2.2.

28.4.2.5 *Examples of results*

Substance	Mass (kg)	Packaging	Heat loss per unit mass (mW/kg.K)	SADT/SAPT (°C)
Azodicarbonamide	30	1G	100	> 75
tert-Butyl peroxybenzoate	25	6HG2	70	55
tert-Butyl peroxy-2-ethylhexanoate	25	6HG2	70	40
tert-Butyl peroxy-pivalate	25	6HG2	70	25

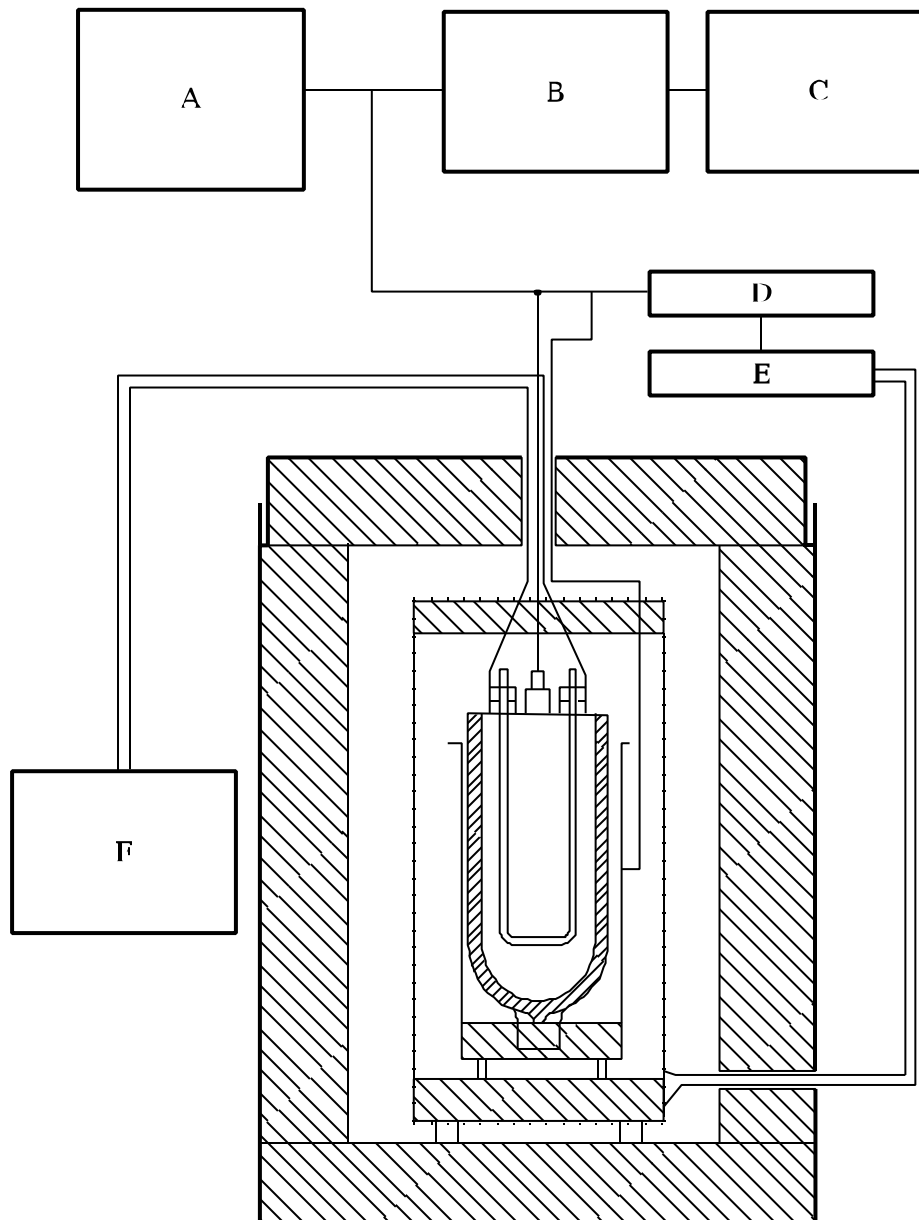

-
- (A) Multi-point recorder and temperature controller (10 mV)
 - (B) External zero set
 - (C) Recorder set for greatest accuracy
 - (D) Control
 - (E) Relay
 - (F) Internal pre-heater
-

Figure 28.4.2.1: ADIABATIC STORAGE TEST

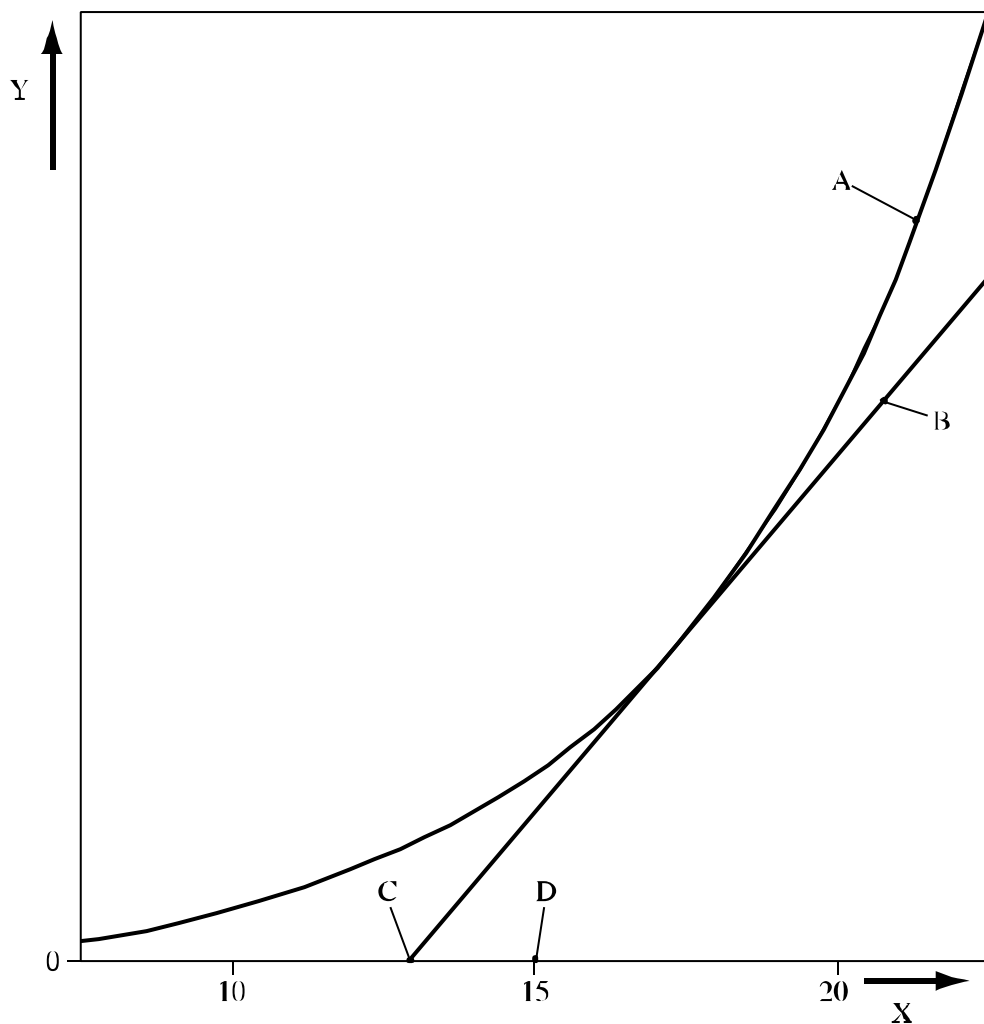

- (A) Heat generation curve
- (B) Line with gradient equal to the rate of heat loss and tangential to the heat generation curve
- (C) Critical ambient temperature (intercept of heat loss line with the abscissa)
- (D) ~~Self-accelerating decomposition temperature (SADT or SAPT)~~ - critical ambient temperature rounded up to next higher multiple of 5 °C
- (X) Temperature
- (Y) Heat flow (generation or loss) per unit mass

Figure 28.4.2.2: EXAMPLE OF DETERMINATION OF SADT OR SAPT

28.4.3 *Test H.3: Isothermal storage test (IST)*

28.4.3.1 *Introduction*

28.4.3.1.1 This method determines the rate of heat generation produced by reacting or decomposing substances as a function of time at constant temperature. The heat generation parameters obtained are used with the heat loss data relating to the package to determine the SADT or SAPT of a substance in its packaging. The method is appropriate for every type of packaging including IBCs and tanks. Some substances may show an increase in the rate of heat generation with increasing decomposition (e.g. due to autocatalysis or induced decomposition). This property is also taken into account by this test method.

28.4.3.1.2 Measurements can be performed in the temperature range of -20 °C to 200 °C. Heat generation values can be measured from 5 mW/kg to 5 W/kg. The thermal resistance between the sample holder and aluminium block via the heat flow meters is about 0.1 W/°C. The apparatus is able to measure rates of heat generation from 15 mW/kg to 1 500 mW/kg with a maximum error of 30% at 15 mW/kg and 5% from 100 to 1 500 mW/kg.

28.4.3.1.3 The robust construction of the apparatus, the relatively small sample size and the well-defined operating conditions enable the test to be performed in an ordinary laboratory. The effects of a thermal explosion, e.g. fragmentation of the sample holder and generation of pressure, should be contained within the apparatus.

28.4.3.2 *Apparatus and materials*

28.4.3.2.1 The apparatus consists of an air-insulated heat sink (an aluminium block) which is kept at a constant temperature by means of controlled heating. A cryostat is used to maintain temperatures below 40 °C. The heat controller is capable of maintaining the temperature to within 0.2 °C of the set temperature. The temperature of the heat sink is measured with a platinum-resistance sensor. The two holes drilled in the block contain heat flow meters (e.g. Peltier elements). A schematic drawing of the IST is given in Figure 28.4.3.1. For substances with an SADT or SAPT below ambient temperature, the test should be performed in a cooling chamber or solid carbon dioxide should be used for cooling the oven.

28.4.3.2.2 Holders are placed on both heat flow meters: one with the sample and one with an inert substance. Both holders are identical and have a volume of 70 cm³. The amount of substance in each holder is about 20 g. The holders are made of glass or stainless steel. The steel must be compatible with the test substance. When using a glass holder, it is provided with a long capillary tube which prevents pressure build-up in the holder and evaporation of the sample.

28.4.3.2.3 The voltage difference resulting from the difference in heat flow from sample holder to the heat sink and inert substance holder to the heat sink is continuously recorded as a function of time (differential measurement) by a recorder or computer.

28.4.3.3 *Procedure*

28.4.3.3.1 Calibration procedure

Before a measurement can be performed, the blank signal and the sensitivity of the heat flow meter need to be determined by the following calibration procedure.

- (a) Set the IST at the selected test temperature;
- (b) Insert a heating coil in the sample holder. Fill the sample and reference holders with inert material (e.g. sodium chloride or milled glass beads) ensuring that the heating coil is completely covered with material. Place both holders in the IST;

- (c) Determine the blank signal (the output of the recorder when no electric power is applied to the heating coil);
- (d) Determine the sensitivity of the heat flow meter using two or three different electrical heating powers which lie within the expected range of heat generation of the sample to be tested.

28.4.3.3.2 Test procedure

The test procedure is as follows:

- (a) Set the IST for the desired test temperature;
- (b) Fill the sample holder with the weighed sample and with a representative quantity of packaging material (if metal) and insert the holder into the apparatus. The amount of sample should be sufficient to give a rate of heat generation between 5 mW to 1 500 mW per kg of substance;
- (c) Start monitoring the rate of heat production. The results from the first 12 hours of the test should not be used because this period is required for temperature equilibration. The duration of each test depends on the test temperature and on the rate of heat production. The test should last for at least 24 hours after the 12 hour equilibration period but can then be stopped if the rate of heat generation is falling from the maximum or if the rate of heat generation is greater than 1.5 W/kg;
- (d) At the end of the test the change in sample mass should be determined;
- (e) The test is repeated with new samples at temperature intervals of 5 °C so that there are seven results with a maximum heat generation rate between 15 and 1 500 mW/kg.

28.4.3.4 *Test criteria and method of assessing results*

28.4.3.4.1 Calculate the sensitivity, S (mW/mV), of the instrument at the various electrical powers used in the calibration procedure using the following formula:

$$S = \frac{P}{U_d - U_b}$$

where: P = electric power (mW)
 U_d = dummy signal (mV)
 U_b = blank signal (mV)

28.4.3.4.2 Use these values and the test data to calculate the maximum rate of heat generation, Q (mW/kg), at the different test temperatures using the formula:

$$Q = \frac{(U_s - U_b) \times S}{M}$$

where: U_s = sample signal (mV)
M = mass (kg)

28.4.3.4.3 Plot the calculated maximum rate of heat generation per unit of mass as a function of the test temperature on a graph with linear scales and draw the best-fit curve through the plotted points. Determine the heat losses per unit of mass, L (W/kg.°C) of the specific package, IBC or tank (see 28.3.5). Draw a straight line of gradient L tangential to the heat generation curve. The intersection of the straight line and the abscissa is the critical ambient temperature i.e. the highest temperature at which the substance as packaged does not show self-accelerating decomposition. The SADT or SAPT is the critical ambient temperature (°C) rounded to the next higher multiple of 5 °C. An example is given in Figure 28.4.3.2.

28.4.3.5 *Examples of results*

Substance	Mass (kg)	Packaging	Heat loss per unit mass (mW/kg.K)	SADT/SAPT (°C)
Azodicarbonamide	30	1G	100	> 75
tert-Butyl peroxybenzoate	25	6HG2	70	55
tert-Butyl peroxy-2-ethylhexanoate	25	6HG2	70	40
tert-Butyl peroxy-pivalate	25	6HG2	70	25
2,5-Diethoxy-4-morpholinobenzenediazonium zinc chloride (90%)	25	1G	150	45
2,5-Diethoxy-4-morpholinobenzenediazonium tetrafluoroborate (97%)	25	1G	15	55
2,5-Diethoxy-4-(phenylsulphonyl)-benzenediazonium zinc chloride (67%)	25	1G	15	50
2-(N-ethoxycarbonyl-N-phenylamino)-3-methoxy-4-(N-methyl-N-cyclohexylamino)-benzenediazonium zinc chloride (62%)	25	1G	15	45
3-Methyl-4-(pyrrolidin-1-yl) benzenediazonium tetrafluoroborate (95%)	25	1G	15	55

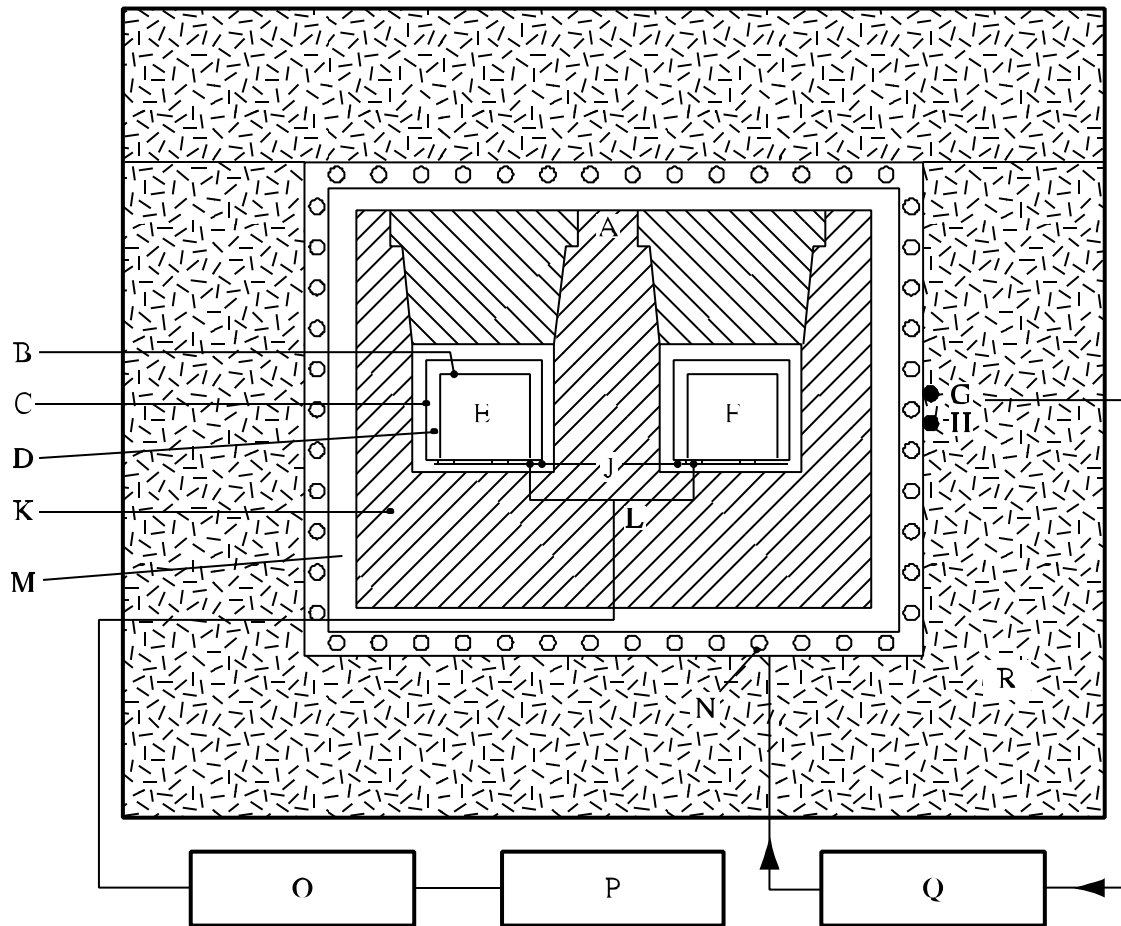

- | | |
|--|---|
| (A) Platinum resistance thermometer | (B) Sample vessel |
| (C) Cylindrical holder | (D) Air spaces |
| (E) Sample | (F) Inert material |
| (G) Platinum resistance sensor for temperature control | (H) Platinum resistance sensor for safety control |
| (J) Peltier elements | (K) Aluminium block |
| (L) Electric circuit | (M) Air space |
| (N) Heating wires | (O) Amplifier |
| (P) Recorder | (Q) Temperature controller |
| (R) Glass wool | |

Figure 28.4.3.1: ISOTHERMAL STORAGE TEST

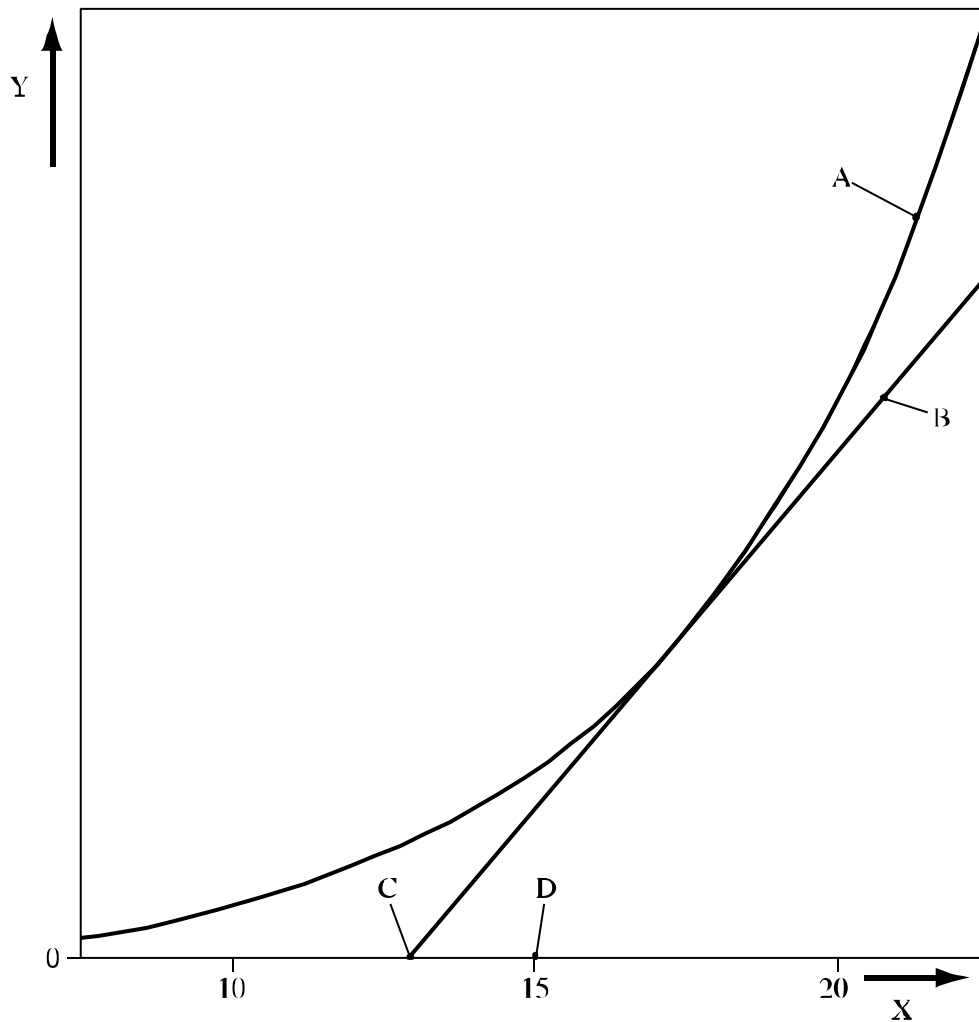

-
- (A) Heat generation curve
 - (B) Line with gradient equal to the rate of heat loss and tangential to the heat generation curve
 - (C) Critical ambient temperature (intercept of heat loss line with the abscissa)
 - (D) ~~Self accelerating decomposition temperature (SADT or SAPT)~~ - critical ambient temperature rounded up to next higher multiple of 5 °C
 - (X) Temperature
 - (Y) Heat flow (generation or loss) per unit mass
-

Figure 28.4.3.2: EXAMPLE OF DETERMINATION OF SADT OR SAPT

28.4.4 *Test H.4: Heat accumulation storage test*

28.4.4.1 *Introduction*

28.4.4.1.1 This method determines the minimum constant air environment temperature at which thermally unstable substances undergo exothermic decomposition at conditions representative of the substance when packaged as for transport. The method is based on the Semenov theory of thermal explosion i.e. the main resistance to heat flow is considered to be at the vessel walls. The method can be used for the determination of the SADT or SAPT of a substance in its packaging, including IBCs and small tanks (up to 2 m³).

28.4.4.1.2 The effectiveness of the method depends on selecting a Dewar vessel with heat loss per unit mass characteristics similar to the package offered for transport.

28.4.4.2 *Apparatus and materials*

28.4.4.2.1 The experimental equipment consists of a suitable test chamber, appropriate Dewar vessels with closures, temperature probes and measuring equipment.

28.4.4.2.2 ***The test should be performed in a test cell capable of withstanding fire and overpressure and, preferably, should be fitted with a pressure relief system e.g. a blow out panel.*** The recording system should be housed in a separate observation area.

28.4.4.2.3 For tests at temperatures up to 75 °C, a double walled metal chamber (ca. 250 mm inner diameter, 320 mm outer diameter and 480 mm high made from 1.5 to 2.0 mm thick stainless steel sheet) is used with fluid from a temperature-controlled circulating bath passed between the walls at the desired temperature. The test chamber is loosely closed by an insulated lid (e.g. made from 10 mm thick polyvinyl chloride). The temperature control should allow the desired temperature for a liquid inert sample in the Dewar vessel to be maintained with a deviation of not more than ± 1 °C for up to 10 days.

28.4.4.2.4 Alternatively, and particularly for tests at temperatures above 75 °C, a thermostatically controlled drying oven (which may be fan-assisted) large enough to allow air circulation on all sides of the Dewar vessel may be used. The air temperature in the oven should be controlled so that the desired temperature for a liquid inert sample in the Dewar vessel can be maintained with a deviation of not more than ± 1 °C for up to 10 days. The air temperature in the oven should be measured and recorded. It is recommended that the door of the oven be fitted with a magnetic catch or replaced by a loosely fitting insulated cover. The oven may be protected by an appropriate steel liner and the Dewar vessel housed in a wire mesh cage.

28.4.4.2.5 For tests at sub-ambient temperatures, a double walled chamber (e.g. a freezer) of suitable size provided with a loose door or lid (e.g. with a magnetic closure) may be used. The temperature of the air in the chamber should be controlled to ± 1 °C of the set temperature.

28.4.4.2.6 Dewar vessels, with their closure system, are used with heat loss characteristics which are representative of the maximum size of package offered for transport. The closure of the Dewar vessel should be inert. Particularly for solids, cork or rubber bungs may be used. A closure system for use with liquids with low or medium volatility is illustrated in Figure 28.4.4.1. Samples which are highly volatile at the test temperature should be tested in a pressure-tight metal vessel fitted with a pressure relief valve. The pressure vessel is placed in the Dewar vessel and the effect of the heat capacity of the metal vessel taken into account by calculation.

28.4.4.2.7 The heat loss characteristics of the system used, i.e. Dewar vessel and closure, should be established (see 28.3.6) prior to performance of the test. Since the closure system has a significant effect on the heat loss characteristics, these can be adjusted to some extent by varying the closure system. In order to achieve the required level of sensitivity, Dewar vessels with sample capacities below 0.5 litres should not be used.

28.4.4.2.8 Dewar vessels, filled with 400 ml of substance, with a heat loss of 80 to 100 mW/kg.K are normally suitable for representing a 50 kg package. For larger packages, IBCs or small tanks larger Dewar vessels with lower heat losses per unit mass should be used. For example, spherical 1 litre Dewar vessels having heat loss characteristics in the range 16 to 34 mW/kg.K may be suitable for IBCs and small tanks.

28.4.4.3 *Procedure*

28.4.4.3.1 Set the test chamber at the selected storage temperature. Fill the Dewar vessel, to 80% of its capacity, with the substance under test and note the mass of the sample. Solids should be moderately compressed. Insert the temperature probe into the centre of the sample. Seal the lid of the Dewar in place and insert the Dewar vessel in the test chamber, connect the temperature recording system and close the test chamber.

28.4.4.3.2 The sample is heated and the temperature of the sample and test chamber continuously monitored. The time is noted at which the sample temperature reaches a temperature 2 °C below the test chamber temperature. The test is then continued for a further seven days or until the sample temperature rises to 6 °C or more above the test chamber temperature if this occurs sooner. Note the time taken for the sample to rise from 2 °C below the test chamber temperature to its maximum temperature.

28.4.4.3.3 If the sample survives, cool and remove it from the test chamber and carefully dispose of it as soon as possible. The percentage mass loss and change in composition may be determined.

28.4.4.3.4 Repeat the test with fresh samples, varying the storage temperature in 5 °C steps. If the substance is being tested to determine if temperature control is necessary, perform sufficient tests to determine the SADT or SAPT to the nearest 5 °C or to determine if the SADT or SAPT is greater than or equal to 60 °C. If the substance is being tested to determine if it meets the SADT or SAPT criterion for a self-reactive substance, perform sufficient tests to determine if the SADT for a 50 kg package is 75 °C or less. *If the substance is being tested to determine if it meets the SAPT criterion for a polymerizing substance, perform sufficient tests to determine if the SAPT in the packaging as used is 75 °C or less.*

28.4.4.4 *Test criteria and method of assessing results*

28.4.4.4.1 The SADT or SAPT is reported as the lowest temperature at which the sample undergoes exceeds the test chamber temperature by 6 °C or more. If the sample temperature does not exceed the test chamber temperature by 6 °C or more in any test, the SADT or SAPT is recorded as being greater than the highest storage temperature used.

28.4.4.5 *Examples of results*

Substance	Sample mass (kg)	Dewar heat loss (mW/kg.K)	SADT/SAP T (°C)
Azodicarbonamide	0.28	74	> 75
Azodicarbonamide, 90% with 10% activator	0.21	70	55
2,2'-Azodi(isobutyronitrile)	0.18	62	50
Benzene-1,3-disulphohydrazide, 50%	0.52	81	70
tert-Butyl hydroperoxide, 80% with 12% di-tert-butyl peroxide	0.30	72	100 ^a
tert-Butyl peroxyneodecanoate, 40%	0.42	65	25
tert-Butyl peroxy-3,5,5-trimethylhexanoate	0.38	79	60
Dibenzoyl peroxide, 50%	0.25	91	60
Di-(4-tert-butylcyclohexyl) peroxydicarbonate	0.19	79	45
2,2-Di-(tert-butylperoxy)butane, 50%	0.31	88	80
Di-(2-ethylhexyl) peroxydicarbonate	0.39	64	0
2,5-Diethoxy-4-morpholinobenzenediazonium zinc chloride (66%)	0.25	58	45
Diisotridecyl peroxydicarbonate	0.38	80	10
Peroxyacetic acid, 15%, with 14% hydrogen peroxide (type F)	1.00	33	> 50 ^b

^a *In a pressure vessel contained with a 2 litres Dewar vessel.*

^b *In a spherical, 1 litre Dewar vessel.*

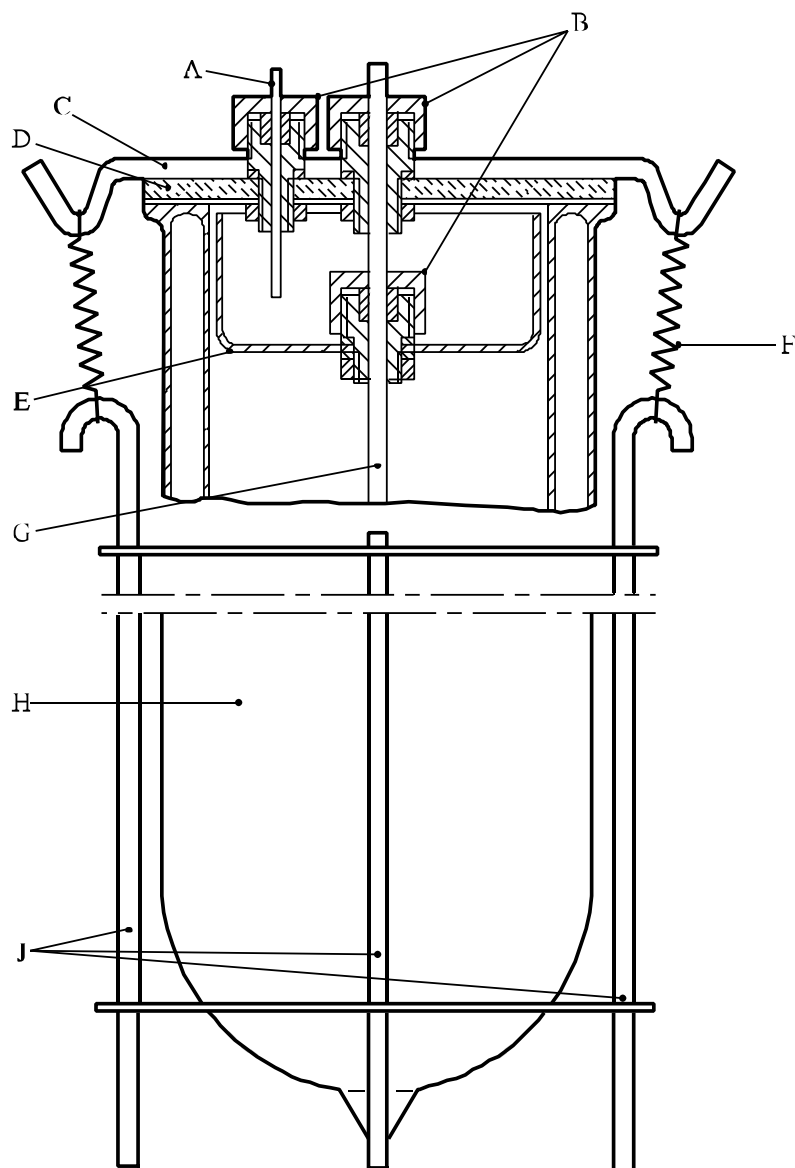

-
- | | |
|----------------------------|--|
| (A) PTFE capillary tube | (B) Special screw fittings (PTFE or Al) with O-ring seal |
| (C) Metal strip | (D) Glass lid |
| (E) Glass beaker base | (F) Spring |
| (G) Glass protective tube | (H) Dewar vessel |
| (J) Steel retaining device | |
-

Figure 28.4.4.1: DEWAR VESSEL WITH CLOSURE FOR TESTING LIQUIDS AND WETTED SOLID