



Economic and Social Council

Distr.: General
6 April 2017

Original: English

Economic Commission for Europe

Inland Transport Committee

World Forum for Harmonization of Vehicle Regulations

172nd session

Geneva, 20-23 June 2017

Item 4.8.2 of the provisional agenda

**1958 Agreement: Consideration of draft amendments
to existing Regulations submitted by GRRF**

Proposal for Supplement 7 to the 01 series of amendments to Regulation No. 55 (Mechanical coupling)

Submitted by the Working Party on Brakes and Running Gear*

The text reproduced below was adopted by the Working Party on Brakes and Running Gear (GRRF) at its eighty-third session (ECE/TRANS/WP.29/GRRF/83, para. 19). It is based. It is submitted to the World Forum ECE/TRANS/WP.29/GRRF/2017/3 as amended by para. 19 and Annex III to the report for Harmonization of Vehicle Regulations (WP.29) and to the Administrative Committee (AC.1) for consideration at their June 2017 sessions.

* In accordance with the programme of work of the Inland Transport Committee for 2016–2017 (ECE/TRANS/254, para. 159 and ECE/TRANS/2016/28/Add.1, cluster 3.1), the World Forum will develop, harmonize and update Regulations in order to enhance the performance of vehicles. The present document is submitted in conformity with that mandate.

GE.17-05583(E)



* 1 7 0 5 5 8 3 *

Please recycle



Supplement 7 to the 01 series of amendments to Regulation No. 55 (Mechanical coupling)

Insert a new paragraph 1.2.1.1., to read:

"1.2.1.1. For the purpose of this Regulation a dolly is defined as a towing trailer designed for the sole purpose to tow a semi-trailer."

Paragraph 2.11., amend to read:

"2.11. The characteristic values D, D_c, S, V and A_v are defined and verified as:"

Paragraph 2.11.1., amend to read:

"2.11.1. The D and D_c value are characteristic performance values for the horizontal forces of the coupling equipment verified as described in Annex 6 to this Regulation."

Paragraph 2.11.2. amend to read:

"2.11.2. The U value is a characteristic performance value for the vertically imposed mass, in tonnes, on the fifth wheel coupling. This performance value shall be verified as described in Annex 6 to this Regulation."

Paragraph 2.11.3. amend to read:

"2.11.3. The S value is a characteristic performance value for the vertically imposed mass, in kilograms, to the coupling from a center axle trailer under static conditions. This performance value shall be verified as described in Annex 6 to this Regulation."

Paragraph 2.11.4., amend to read:

"2.11.4. The V value is a characteristic performance value of the amplitude of the vertical force imposed on the coupling by a center axle trailer. This performance value shall be verified as described in Annex 6 to this Regulation."

Insert a new paragraph 2.11.5., to read:

"2.11.5. The A_v value is a characteristic performance value for hinged drawbars that sets maximum permitted axle mass in tonnes of the front steered axle group of a full trailer. This performance value shall be verified as described in Annex 6 to this Regulation."

Insert a new paragraph 2.11.6. to read:

"2.11.6. To each of the characteristic performance value D, D_c, U, V and S there are corresponding application requirement values. Those requirements values are determined according to Annex 8 to this Regulation."

Paragraph 2.12., amend to read:

"2.12. Symbols and definitions used in Annex 6 and Annex 8 to this Regulation.

A_v = maximum permitted axle mass in tonnes of the front steered axle group of a full trailer – see paragraph 2.11.5.

C = mass of centre axle trailer in tonnes – see Annex 8, paragraph 2.1. to this Regulation.

D = D-value in kN - see paragraph 2.11.1. of this Regulation.

- D_c = D_c -value in kN for centre axle trailers - see paragraph 2.11.1. of this Regulation.
- R = mass of towed vehicle in tonnes - see Annex 8, paragraph 2.1. to this Regulation.
- T = mass of towing vehicle in tonnes - see Annex 8, paragraph 2.1. to this Regulation.
- F_a = static lifting force in kN.
- F_h = horizontal component of test force in longitudinal axis of vehicle in kN.
- F_s = vertical component of test force in kN.
- S = static vertical mass in kg. - See paragraph 2.11.3. of this Regulation.
- U = fifth wheel imposed vertical mass in tonnes. – See paragraph 2.11.2. of this Regulation.
- V = V -value in kN - see paragraph 2.11.4. of this Regulation.
- a = equivalent vertical acceleration factor at the coupling point of centre axle trailers depending on the type of suspension of the rear axle(s) of the towing vehicle - see Annex 8, paragraph 2.2. to this Regulation.
..."

Paragraph 2.16., amend to read:

- "2.16. *"Secondary coupling device"* means a chain, wire rope, etc., fitted a coupling device, capable in the event of separation of the main coupling, of ensuring that the trailer remains connected to the towing vehicle and that there is some residual steering action."

Paragraph 3.2.3., amend to read:

- "3.2.3. A statement of the values of D , D_c , S , V and U as applicable and as defined in paragraph 2.11.

For towing devices intended for M_1 or N_1 vehicle, a statement of the maximum permissible towing vehicle and trailer masses and the maximum permissible static vertical imposed load on the towing device as advised by the manufacturer of the towing vehicle; if the value for the maximum permissible towable mass is zero or no value declared by vehicle manufacturer, the application for approval shall be refused."

Paragraph 4.8. (former), shall be renumbered as paragraph 4.10.

Insert a new paragraph 4.8. to read:

- "4.8. Towing brackets / drawbeams which are intended to tow trailers up to 3.5t shall incorporate attachment points, to which either secondary couplings or devices necessary to enable the trailer to be guided and/or stopped automatically in the event of separation of the main coupling, may be attached. Other than for detachable units, as an alternative, an attachment point may be integrated to coupling component fitted to the towing bracket/drawbeam. The installation and operating instructions specified in 4.6. shall include all the information for the correct use these attachment points.
- 4.8.1. The attachment points for a secondary coupling and/or breakaway cable shall be positioned such that when in use, the secondary coupling or breakaway

cable does not restrict the normal articulation of the coupling or interfere with the normal inertia braking system operation. A single attachment point shall be positioned within 100 mm of a vertical plane passing through the center of articulation of the coupling. If this is not practicable, two attachment points shall be provided, one on each side of the vertical center line and equidistant from the center line by a maximum of 250 mm. The attachment point(s) shall be as rearward and as high as practicable.

4.8.2. The attachment points above shall comply with the requirement defined in paragraph 3.1.8. of Annex 6."

Insert a new paragraph 4.9., to read:

"4.9. Coupling heads/ coupling drawbar eyes, intended to be fitted to un-braked O₁ trailers, shall be fitted with a secondary coupling device or at least attachment point(s) to permit the connection of a secondary coupling device(s).

4.9.1. The attachment point(s) shall be positioned such that when in use, the secondary coupling device(s) does not restrict the normal articulation of the coupling.

4.9.2. The attachment point(s) above shall comply with the requirement defined in paragraph 3.2.4. of Annex 6."

Paragraph 5.3.5., amend to read:

"5.3.5. A statement of the characteristic performance values of D, D_c, S, V and U as applicable and as defined in paragraph 2.11."

Paragraph 5.3.5.1., amend to read:

"5.3.5.1. The characteristic performance values of the coupling equipment installed on the vehicle shall be verified according to Annex 8 to this Regulation applying the maximum permissible towing vehicle, trailer and combination masses."

Annex 2,

Add a new item 6. to read:

"6. Maximum permissible masses"

Item 6. (former), renumber and amend to read:

"6.1. Two-vehicle combinations
 Maximum permissible vehicle mass: kg
 Distribution of maximum permissible vehicle mass between the axles:

 Maximum permissible towable trailer mass: kg
 Maximum permissible static mass on coupling ball: kg"

Add a new item 6.2. to read:

"6.2. Multi vehicle combinations (according to Annex 8)
 Maximum permissible combination mass: kg
 Maximum permissible vehicle mass: kg
 Distribution of maximum permissible vehicle mass between the axles:

 Maximum permissible towable mass..... kg
 Limiting V-value (as applicable) kN"

Item 7., amend to read:

- "7. Performance values of coupling equipment installed:
 D:..... kN D_c:..... kN S:..... kg
 U:..... tonnes V:..... kN
 In case of a towing trailer, performance values of the coupling equipment installed at the rear:
 D:..... kN D_c:..... kN S:..... kg
 U:..... tonnes V:..... kN"

Annex 5,

Paragraphs 1.6. and 1.6.1., shall be deleted:

Paragraphs 1.7. and 1.8. (former) shall be renumbered as paragraphs 1.6. and 1.7.

Paragraph 2.1. amend to read:

- "2.1. Coupling heads of Class B50 shall be designed so that they can be used safely with the coupling balls described in paragraph 1. of this annex and thereby retain the prescribed characteristics.
 Coupling heads shall be designed in such a way that safe coupling is ensured, also taking into account the wear of the coupling devices."

Figure 12, dimension sleeve bore diameter, amend as follow:

For "Ø06H8" read "Ø60H8"

Figure 17, amend to read:

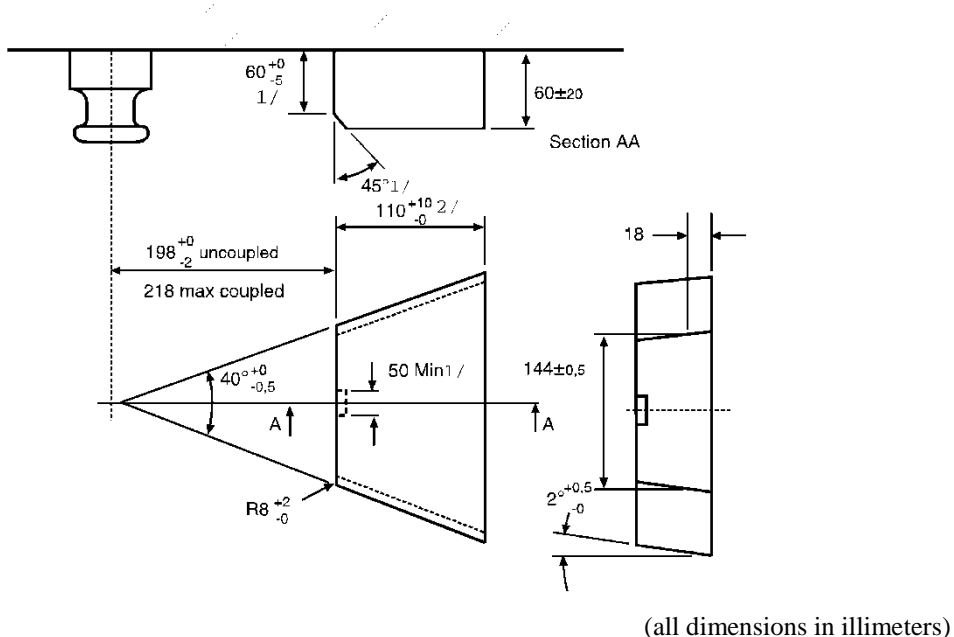

Annex 6,

Paragraph 1.1., amend to read:

- "1.1. Samples of coupling devices shall be tested for both strength and function. Tests shall be performed in relation to worst case conditions.

Theoretical assessment may be carried out to determine worst case conditions. Physical testing shall be carried out wherever possible but unless stated otherwise the Type Approval Authority or Technical Service may waive a physical strength test if the simple design of a component makes a theoretical assessment possible.

In all cases, theoretical assessments shall ensure the same quality of results as with dynamic or static testing. In cases of doubt it is the results of physical testing that are overriding.

See also paragraph 4.10. of this Regulation."

Paragraph 3.1.8., amend to read:

"3.1.8. The attachment points for the secondary coupling referred to paragraph 4.8. shall withstand a horizontal static force equivalent to 2D with a maximum of 15 kN. Where there is a separate attachment point for a breakaway cable this shall withstand a horizontal static force equivalent to D."

Paragraph 3.2.4., amend to read:

"3.2.4. The secondary coupling device(s) attachment point(s) referred to in paragraph 4.9. shall withstand a static force equivalent to 2D with a maximum of 15 kN"

Paragraph 3.6.1., amend to read:

"3.6.1. Drawbars shall be tested in the same way as drawbar eyes (see para. 3.4.). The Type Approval Authority or Technical Service may waive an endurance test if the simple design of a component makes a theoretical assessment of its strength possible. The design forces for the theoretical verification of the drawbar of centre axle trailers with a mass, C, of up to and including 3.5 tonnes shall be taken from ISO 7641/1:1983. The design forces for the theoretical verification of drawbars for centre axle trailers having a mass, C, over 3.5 tonnes shall be calculated as follows:

$$F_{sp} = (g \times S/1000) + V$$

Where the force amplitude V is that defined in paragraph 2.11.4. of this Regulation.

The permissible stresses based on the design masses for trailers having a total mass, C, over 3.5 tonnes shall be in accordance with paragraph 5.3. of ISO 7641/1:1983. For bent drawbars (e. g. swan neck) and for the drawbars of full trailers, the horizontal force component $F_{hp} = 1.0 \times D$ shall be taken into consideration."

Insert a new Annex 8, to read:

"Annex 8

Verification procedure for vehicle with respect to coupling equipment installed

1. General

The objective of this annex is to provide a procedure and acceptance criterion to verify that the characteristic performance values of the coupling equipment

installed on the vehicle to be approved are sufficient to sustain the maximum towable mass and other technical characteristics of the vehicle / combination.

1.1 Verification procedure and acceptance criteria

The performance value requirements shall be calculated using the relevant formulae of paragraphs 2 and 3 of this annex, applying the maximum permissible towing vehicle, trailer and combination masses which are specified by the vehicle manufacturer in the Annex 2 to this Regulation.

The acceptance criteria are fulfilled:

- (a) If the calculated performance value requirements are not higher than the characteristic performance values of the coupling equipment,
- (b) If, in case of a drawbar coupling not fulfilling the above criteria, the calculated performance value requirements and the limiting V-value specified by the vehicle manufacturer fulfill all the criteria specified in paragraph 4 of this annex.

2. Calculation formulae applicable to Two-vehicle combinations

2.1. Horizontal forces

For mechanical coupling devices and components not designed to support imposed vertical loads, the value is:

$$D = g \frac{T * R}{T + R} \text{ kN}$$

For mechanical coupling devices and components for center axle trailers as defined in 2.13, the value is:

$$D_C = g \frac{T * C}{T + C} \text{ kN}$$

For fifth wheel couplings of Class G, fifth wheel coupling pins of Class H and mounting plates of Class J, as defined in paragraph 2.6., the value is:

$$D = g \frac{0.6 * T * R}{T + R - U} \text{ kN}$$

where:

T is the technically permissible maximum mass of the towing vehicle, in tonnes. Where relevant, this includes the vertical load imposed by a center axle trailer¹.

R is the technically permissible maximum mass, in tonnes, of a trailer with drawbar free to move in a vertical plane, or of a semitrailer¹.

C is the mass, in tonnes, transmitted to the ground by the axle or axles of the center axle trailer, as defined in paragraph 2.13., when coupled to the towing vehicle and loaded to the technically permissible maximum mass¹. For Category O1 and O2 center axle trailers² the technically permissible

¹ The mass T and R and the technically permissible maximum mass, may be greater than the permissible maximum mass prescribed by national legislation.

² See definitions in Regulation No. 13 annexed to the 1958 Agreement concerning the Adoption of Uniform Technical Prescriptions for Wheeled Vehicles, Equipment and Parts which can be Fitted and/or be Used on Wheeled Vehicles and the Conditions for Reciprocal Recognition of Approvals Granted on the Basis of these Prescriptions. The definition is also contained in Annex 7 to the Consolidated Resolution on the Construction of Vehicles (R.E.3) (document ECE/TRANS/WP.29/78/Rev.4).

maximum mass will be that declared by the manufacturer of the towing vehicle.

Towable mass: R or C (as applicable)

2.2. Vertical forces from center axle trailer

The vertical force imposed on the coupling by the center axle trailer of technically permissible maximum mass greater than 3.5 tonnes is:

$$V = \frac{a \cdot C \cdot X^2}{L^2} \text{ kN} \quad (\text{See the Note below})$$

where:

C is as defined in paragraph 2.1. of this Annex

a is an equivalent vertical acceleration at the coupling depending on the type of suspension system of the rear axle of the towing vehicle.

For air suspension (or suspension systems with equivalent damping characteristics)

$$a = 1.8 \text{ m/s}^2$$

For other types of suspension:

$$a = 2.4 \text{ m/s}^2$$

X is the length of the loading area of the trailer, in meters (see Figure 27)

L is the distance from the center of the drawbar eye to the center of the axle assembly, in meters (see Figure 27)

Note: $\frac{X^2}{L^2} \geq 1.0$ (If less than 1.0, the value of 1.0 shall be used)

Figure 27

Dimensions of the center axle trailer

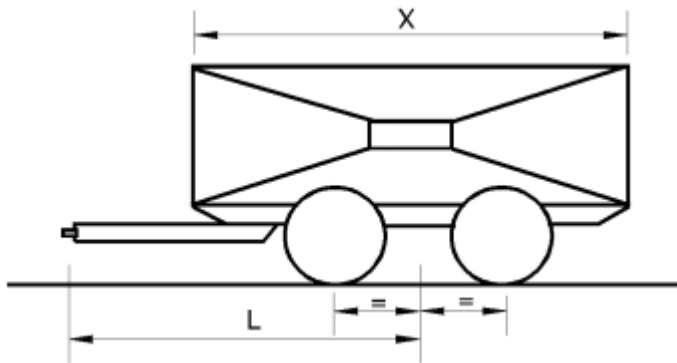

Towable mass: C

3. Calculation formulae applicable to Multi-vehicle combinations

3.1. Combination 1:

Description: Rigid truck + Dolly + Semitrailer

Masses [tonnes]:

M₁ = total axle load of rigid truck as coupled

M₂ = total axle load of dolly and semitrailer as coupled

M₃ = total axle load of dolly as coupled

M_4 = total axle load of rigid truck as coupled plus tare weight of dolly

M_5 = support load at king-pin of semitrailer

M_6 = M_5 + total axle load of semitrailer as coupled

Total combination mass = $M_1 + M_2$

Towable mass of the rigid truck: M_2

Towable mass of the dolly: M_6

Dimensions:

L = distance from drawbar eye to center of dolly axle group [m]

Coupling capability requirement:

Clevis coupling: $D = g \frac{M_1 * M_2}{M_1 + M_2} \dagger$ $V = \text{Max}(\frac{5.4}{L}; 5 \frac{M_3}{L}) \dagger$

Fifth wheel: $D = 0.5g \frac{M_4(M_6 + 0.08M_4)}{M_4 + M_6 - M_5}$

† Dolly with rigid drawbar:

This calculated D-value requirement shall be lower than the certified D_C -value performance of coupling equipment used.

Dolly with hinged drawbar:

This calculated D-value requirement shall be lower than the certified D-value performance of coupling equipment used. With a hinged drawbar there is no V-value requirement.

3.2. Combination 2:

Description: Tractor + Semitrailer + center axle trailer

Masses [tonnes]:

M_1 = total axle load of tractor as coupled (including support load from semitrailer)

M_2 = total axle load of center axle trailer as coupled

M_3 = total axle load of tractor and semitrailer as coupled

M_4 = support load at king-pin of semitrailer

M_5 = M_4 + total axle load of semitrailer and center axle trailer as coupled

Total combination mass = $M_2 + M_3$

Towable mass of the tractor: M_5

Towable mass of the semitrailer: M_2

Dimensions:

L = distance from drawbar eye to center of center axle trailer axle group [m]

X = length of loaded area of center axle trailer [m]

$a = 2.4$ [m/s^2] for semitrailer with steel suspension; 1.8 [m/s^2] for semitrailer with air suspension

Coupling capability requirement:

Clevis coupling on semitrailer: $D_c = 0.65g \frac{M_3 * M_2}{M_3 + M_2}$ $V = a \frac{X^2}{L^2} M_2$

$$\text{Fifth wheel: } D = 0.5g \frac{M_5(M_1 + 0,08M_5)}{M_1 + M_5 - M_4}$$

Note: $\frac{x^2}{L^2} \geq 1.0$ (If less than 1.0, the value of 1.0 shall be used)

3.3. Combination 3:

Description: Tractor + Semitrailer + Dolly + Semitrailer

Masses [tonnes]:

M_1 = total axle load of tractor as coupled (including support load from first semitrailer)

M_2 = total axle load of tractor and first semitrailer as coupled

$M_3 = M_4$ + total axle load of second semitrailer as coupled

M_4 = total axle load of dolly as coupled (including support load from second semitrailer)

$M_5 = M_2$ + tare weight of dolly

M_6 = support load at king-pin of first semitrailer

M_7 = support load at king-pin of second semitrailer

$M_8 = M_7$ + total axle load of second semitrailer as coupled

$M_9 = M_6$ + total axle load of first semitrailer as coupled + M_3

Total combination mass = $M_2 + M_3$

Towable mass of the tractor: M_9

Towable mass of the first semitrailer: M_3

Towable mass of the dolly: M_8

Dimensions:

L = distance from drawbar eye to center of dolly axle group [m]

Coupling capability requirement:

Clevis coupling on first semitrailer:

$$D = 0.65g \frac{M_2 * M_3}{M_2 + M_3} \dagger$$

$$V = \text{Max}\left(\frac{5^4}{L}; 5 \frac{M_4}{L}\right) \dagger$$

Fifth wheel: $D = \text{Max}(D_1; D_2)$, with:

$$D_1 = 0.5g \frac{M_5(M_8 + 0,08M_5)}{M_5 + M_8 - M_7}$$

$$D_2 = 0.5g \frac{M_9(M_1 + 0,08M_9)}{M_9 + M_1 - M_6}$$

† Dolly with rigid drawbar:

This calculated D-value requirement shall be lower than the certified D_C -value performance of coupling equipment used.

Dolly with hinged drawbar:

This calculated D-value requirement shall be lower than the certified D-value performance of coupling equipment used. With a hinged drawbar there is no V-value requirement.

3.4. Combination 4:

Description: Rigid truck + center axle trailer + center axle trailer

Masses [tonnes]:

 M_1 = total axle load of rigid truck as coupled M_2 = total axle load of first center axle trailer as coupled M_3 = total axle load of second center axle trailer as coupled $M_4 = M_2 + M_3$ $M_5 = M_1 + M_2$ Towable mass of the rigid truck: M_4 Towable mass of the first center axle trailer: M_3 Total combination mass = $M_1 + M_2 + M_3$

Dimensions:

 L_1 = distance from drawbar eye to center of the axle group of the first center axle trailer [m] L_2 = distance from drawbar eye to center of the axle group of the second center axle trailer [m] X_1 = length of loaded area of the first center axle trailer [m] X_2 = length of loaded area of the second center axle trailer [m] T_1 = distance from center of axle group to coupling point of clevis coupling in rear end of first center axle trailer [m] $a = 2.4$ [m/s²] for semitrailer with steel suspension; 1.8 [m/s²] for semitrailer with air suspension

Coupling capability requirement:

Clevis couplings: $D_c = 0.9g \frac{M_1 * M_4}{M_1 + M_4}$

$$V = V_1$$

$$V_2 = a \frac{X_2^2}{L_2^2} M_3$$

$$V_1 = \sqrt{\left(a \frac{X_1^2}{L_1^2} M_2\right)^2 + \left(\frac{T_1^2}{L_1^2} V_2\right)^2}$$

Note: $\frac{X_1^2}{L_1^2} \geq 1$ $\frac{X_2^2}{L_2^2} \geq 1$ (If less than 1.0, the value of 1.0 shall be used)

3.5. Combination 5:

Description: Tractor + Link-trailer* + Semitrailer

Masses [tonnes]:

 M_1 = total axle load of tractor as coupled (including support load from link-trailer) M_2 = support load at king-pin of link-trailer

$M_3 = M_2 + \text{total axle load of link-trailer and semitrailer as coupled}$

$M_4 = \text{total axle load of link-trailer and semitrailer as coupled}$

$M_5 = \text{support load at king-pin of semitrailer}$

$M_6 = M_5 + \text{total axle load of semitrailer}$

Total combination mass = $M_1 + M_4$

Towable mass of the tractor: M_3

Towable mass of the linktrailer: M_6

Coupling capability requirement:

Fifth wheel:
$$D = 0.5g \frac{M_3(M_1 + 0.08M_3)}{M_1 + M_3 - M_2}$$

* Link-trailer is a semitrailer equipped with a fifth wheel in its rear end enabling a second semitrailer to be towed.

4. Performance extension

The designations D_{cert} , D_{C-cert} , V_{cert} and S_{cert} used below in this paragraph designate certified performance values of the coupling component under consideration. The designation D_{C-req} , V_{req} and S_{req} designate vehicle combination performance value requirements as calculated in accordance with the rules in this annex. They are to be evaluated against certified performance values.

4.1. Clevis coupling systems including drawbeams and drawbar eyes

For each combination of certified performance values a diagram as shown in the Figure 28 may be drawn. Calculated performance value requirements D_{C-req} and V_{req} that would fall in the hatched area of the diagram are allowed to be operated in road traffic.

S_{req} shall always be below or equal to 1000 kg.

Figure 28

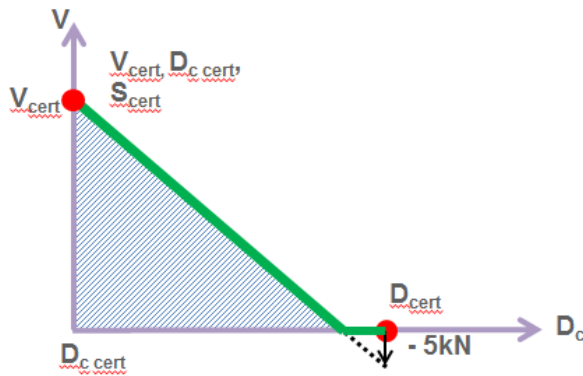

4.2. If the calculated performance value requirements fall within the hatched area of figure 28, the towable mass is verified with a limiting V-value. For the combination concerned the limiting V-value overrules the certified V-value of the coupling equipment installed.

4.2.1. The limiting V-value is given by a point on the sloping line in figure 28. This point corresponds to the D_c -value requirement calculated for the towable mass."

