



---

## Committee of Experts on the Transport of Dangerous Goods and on the Globally Harmonized System of Classification and Labelling of Chemicals

### Sub-Committee of Experts on the Transport of Dangerous Goods

#### Fiftieth session

Geneva, 28 November-6 December 2016

Item 2 (a) of the provisional agenda

**Recommendations made by the Sub-Committee  
 on its forty-seventh, forty-eighth  
 and forty-ninth sessions and pending issues:  
 review of draft amendments already  
 adopted during the biennium**

### Consolidated list of adopted texts

#### Note by the secretariat<sup>1</sup>

This document contains a consolidated list of texts adopted by the Sub-Committee of Experts at its forty-seventh, forty-eighth and forty-ninth sessions, as follows:

	<i>Page</i>
Part I. Draft amendments to the sixth revised edition of the Recommendations on the Transport of Dangerous Goods, Manual of Tests and Criteria (ST/SG/AC.10/11/Rev.6).....	2
Part II. Draft amendments to the nineteenth revised edition of the Recommendations on the Transport of Dangerous Goods, Model Regulations (ST/SG/AC.10/1/Rev.19).....	11

---

<sup>1</sup> In accordance with the programme of work of the Sub-Committee for 2015–2016 approved by the Committee at its seventh session (see ST/SG/AC.10/C.3/92, paragraph 95 and ST/SG/AC.10/42, para. 15).

## Part I

### **Draft amendments to the sixth revised edition of the Recommendations on the Transport of Dangerous Goods, Manual of Tests and Criteria (ST/SG/AC.10/11/Rev.6)**

#### **Section 1**

1.1.2 Amend the second sentence to read as follows: “It therefore assumes technical competence on the part of the testing body.”.

*(Reference document: ST/SG/AC.10/C.3/98/Add.1)*

#### **Section 11**

11.5.1.2.1 (d) Replace “ $30 \pm 3$  MPa” by “ $29 \text{ MPa} \pm 4 \text{ MPa}$ ”.

*(Reference document: ST/SG/AC.10/C.3/98/Add.1)*

#### **Section 12**

12.5.1.2.1 (d) Replace “ $30 \pm 3$  MPa” by “ $29 \text{ MPa} \pm 4 \text{ MPa}$ ”.

*(Reference document: ST/SG/AC.10/C.3/98/Add.1)*

#### **Section 18**

18.6.1.2.1 (d) Replace “ $30 \pm 3$  MPa” by “ $29 \text{ MPa} \pm 4 \text{ MPa}$ ”.

*(Reference document: ST/SG/AC.10/C.3/98/Add.1)*

#### **Section 25**

25.4.1.2.1 (d) Replace “ $30 \pm 3$  MPa” by “ $29 \text{ MPa} \pm 4 \text{ MPa}$ ”.

*(Reference document: ST/SG/AC.10/C.3/98/Add.1)*

#### **Section 33**

[33.2.1.4.4.1 Amend the last sentence to read as follows: “Powders of metals or metal alloys should be classified when they can be ignited and the reaction spreads over the whole length (100 mm) of the sample in 10 minutes or less.”].

[33.2.1.4.4.2 Amend the last sentence to read as follows: “Packing group II should be assigned to powders of metals or metal alloys if the zone of reaction spreads over the whole length (100 mm) of the sample in five minutes or less.”].

[33.2.1.4.4.3 Amend the last sentence to read as follows: “Packing group III should be assigned to metal powders if the reaction spreads over the whole length (100 mm) of the sample in more than five minutes but not more than ten minutes.”].

*(Reference document: ST/SG/AC.10/C.3/98/Add.1)*

## Section 38

38.3.2.1 At the end, add the new following sentence: “A cell or battery that is an integral part of the equipment it is intended to power that is transported only when installed in the equipment, may be tested in accordance with the applicable tests when installed in the equipment.”.

*(Reference document: ST/SG/AC.10/C.3/98/Add.1)*

38.3.2.3 Amend the definition of “Disassembly” to read as follows:

“*Disassembly* means a rupture of the cell or battery case where solid components are ejected.

**NOTE:** *During cell or component cell testing, ejection of internal components is acceptable. Energy of ejected components shall be limited and can be measured as follows:*

(a) *It will not penetrate a wire mesh screen (annealed aluminium wire with a diameter of 0.25 mm and grid density of 6 to 7 wires per cm) placed 25 cm away from the cell; or*

(b) *It can be measured by a method demonstrated to be equivalent to the one described in sub-paragraph (a) above.”.*

*(Reference document: ST/SG/AC.10/C.3/98/Add.1)*

38.3.3 (b) In (i), replace “ten” by “five”. Add a new paragraph (ii) to read as follows and renumber the following paragraphs consequently: “Five cells after 25 cycles ending in fully charged states;”. In paragraph (iv) (previously (iii)), replace “50” by “25”.

*(Reference document: ST/SG/AC.10/C.3/98/Add.1)*

38.3.3 (c) In paragraph (iii), after “rated capacity” add “and five cells after 25 cycles ending in fully charged states;”. In paragraph (iv), after “rated capacity” add “and five cells after 25 cycles ending in fully charged states;”.

*(Reference document: ST/SG/AC.10/C.3/98/Add.1)*

38.3.3 (d) In paragraph (ii), replace “50” by “25”.

*(Reference document: ST/SG/AC.10/C.3/98/Add.1)*

38.3.3 (e) In paragraphs (v) and (vi), replace “50” by “25”.

*(Reference document: ST/SG/AC.10/C.3/98/Add.1)*

38.3.3 Add the following new 38.3.3.1

“38.3.3.1 Provisions 38.3.2.1 and 38.3.3 are summarized in the following table

Table 38.3.2: Summary table of required tests for primary cells and batteries

Primary cells and batteries											
		T.1	T.2	T.3	T.4	T.5	T.6	T.7	T.8	Sum <sup>c</sup>	
Cells not transported separately	undischarged state						5			20	
	fully discharged state						5		10		
Cells	undischarged state	10					5				40
	fully discharged state	10					5		10		
Single cell batteries <sup>a</sup>	undischarged state	10					5				40
	fully discharged state	10					5		10		
Small batteries	undischarged state	4									8
	fully discharged state	4									
Large Batteries	undischarged state	4									8
	fully discharged state	4									
Batteries assembled with tested batteries ≤ 500 g Li	undischarged state			1						1	
Batteries assembled with tested batteries > 500 g <sup>b</sup> Li										0	

<sup>a.</sup> A single cell battery containing one tested cell does not require testing unless a change in cell design could result in the failure of any test.

<sup>b.</sup> If the assembled battery is of a type that has been verified as preventing:

- (i) Overcharge;
- (ii) Short circuits; and
- (iii) Over discharge between the batteries.

<sup>c.</sup> The sum represents the number of tests required, not the number of cells or batteries tested.

**Table 38.3.3: Summary table of required tests for rechargeable cells and batteries**

Rechargeable cells and batteries											
		T.1	T.2	T.3	T.4	T.5	T.6	T.7 <sup>a</sup>	T.8	Sum <sup>d</sup>	
Cells not transported separately from a battery	first cycle, 50% charged state						5			30	
	25th cycle, 50% charged state						5				
	first cycle, fully discharged state								10		
	25th cycle, fully discharged state								10		
Cells	first cycle, fully charged state	5									40
	25th cycle, fully charged state	5									
	first cycle, 50% charged state						5				
	25th cycle, 50% charged state						5				
	first cycle, fully discharged state								10		
	25th cycle, fully discharged state								10		
Single cell batteries <sup>b</sup>	first cycle, fully charged state	5						4			48
	25th cycle, fully charged state	5									
	first cycle, 50% charged state						5				
	25th cycle, 50% charged state						5				
	25th cycle, fully charged state							4			
	first cycle, fully discharged state								10		
	25th cycle, fully discharged state								10		
Small batteries	first cycle, fully charged state	4						4		16	
	25th cycle, fully charged state	4						4			
Large batteries	first cycle, fully charged state	2						2		8	
	25th cycle, fully charged state	2						2			
Batteries assembled with tested batteries ≤ 6 200 Wh or ≤500g Li	fully charged state			1				1		2	
Batteries assembled with tested batteries > 6 200 Wh or >500g Li <sup>c</sup>										0	

<sup>a</sup> Batteries or single cell batteries not equipped with battery overcharge protection that are designed for use only as a component in another battery or in equipment, which affords such protection, are not subject to the requirements of this test;

<sup>b</sup> Except for the T.7 Overcharge test, a single cell battery containing one tested cell does not require testing unless a change in cell design could result in the failure of any test;

<sup>c</sup> *If the assembled battery is of a type that has been verified as preventing:*

- (i) *Overcharge;*
- (ii) *Short circuits; and*
- (iii) *Over discharge between the batteries.*

<sup>d</sup> *the sum represents the number of tests required, not the number of cells or batteries tested.”.*

*(Reference document: ST/SG/AC.10/C.3/98/Add.1)*

## **Section 51**

51.2.2 At the end of the sentence, before the indents, add “, in that state”.

51.2.2 (a) Amend to read as follows:

“(a) They are intended to produce a practical explosive or pyrotechnic effect;”.

51.2.2 (b) Replace “or their corrected burning” by “or the corrected burning”.

51.2.2 (c) Replace “Their exothermic” by “The exothermic”.

*(Reference document: ST/SG/AC.10/C.3/98/Add.1)*

## **Appendix 6**

Amend section 2.3 to read as follows:

“2.3 The remarks 1.1.2 from section 1 «General introduction» are emphasized that technical competence on the part of the testing body is assumed.”.

*(Reference document: ST/SG/AC.10/C.3/98/Add.1)*

Insert a section 5.2 to read as follows:

“5.2 Substances which may be polymerizing substances (Division 4.1)

Provided that the substance is not intended for polymerization, the classification procedure for polymerizing substances need not be applied if:

- (a) The chemical structure of the substance contains no double or triple bonds or strained rings; or
- (b) The compound contains double or triple bonds or strained rings, and the molecular mass M(CHON) counting only the elements C, H, O and N is more than 150; or
- (c) The compound is solid with a melting point above 50 °C.”.

Re-number existing sections 5.2 and 5.3 as 5.3 and 5.4.

*(Reference documents: ST/SG/AC.10/C.3/96/Add.1)*

## **Appendix 7**

Amend the title of the appendix to read as follows: “FLASH COMPOSITION TESTS”. Insert a new subtitle to read: “1. HSL Flash Composition Test”. Re-number existing paragraphs accordingly.

In 1.1 (former 1), after “fireworks, that are used” insert “in waterfalls, or”. In the second sentence, replace “lifting” by “propellant”.

In 1.2.2 (former 2.2), replace “vessel is closed by an aluminium bursting” by “vessel is closed by a brass or aluminium bursting”. In the last sentence, after “lead washer” insert “or a washer of a suitable deformable material (for example, polyoxymethylene)”.

In 1.4 (former 4), after “used in waterfalls,” insert “or to produce an aural effect,”. Replace “lifting” by “propellant”. Amend the table to read as follows:

Composition (mass %)	Use or effect	Mean time for a pressure rise from 690 to 2 070 kPa (ms)	Result
Potassium perchlorate/Aluminium (77/23)	Aural (report)	0.48	Flash composition
Potassium perchlorate/ Barium nitrate/ Aluminium /Magnalium (20/20/45/15)	Aural (report)	2.15	Flash composition
Potassium perchlorate /Potassium benzoate (71/29)	Aural (whistle)	0.89	Flash composition
Potassium perchlorate /Potassium hydrogen terephthalate /Titanium (62/25/13)	Aural (whistle)	1.67	Flash composition
Potassium perchlorate /Aluminium (P2000)/Aluminium (P50) (53/16/31)	Waterfall	2.73	Flash composition
Potassium perchlorate /Aluminium (P2000)/Aluminium (P50)/ Antimony sulphide (50/15/30/5)	Waterfall	1.19	Flash composition
Potassium perchlorate/Charcoal (80/20)	Bursting	0.85	Flash composition
Potassium perchlorate/Charcoal (60/40)	Bursting	2.80	Flash composition
Potassium perchlorate/Charcoal (50/50)	Bursting	9.26	Not flash composition
Potassium perchlorate/ Potassium nitrate /Charcoal (53/26/21)	Bursting	1.09	Flash composition
Potassium perchlorate/ Potassium nitrate /Charcoal (53/26/21) (Cottonseed core)	Bursting	7.39	Not flash composition
Potassium perchlorate/Charcoal /Aluminium (59/23/18)	Bursting	1.14	Flash composition

Insert a new section 2 to read as follows:

## **“2. US Flash Composition Test**

### **2.1 Introduction**

This test may be used to determine if pyrotechnic substances in powder form or as pyrotechnic units as presented in fireworks that are used in waterfalls, or to produce an aural effect or used as a bursting charge or propellant charge, may be considered a “flash composition” for the purposes of the default fireworks classification table in 2.1.3.5.5 of the Model Regulations.

### **2.2 Apparatus and materials**

The experimental set up consists of:

A cardboard or fibreboard sample tube with a minimum inside diameter of 25 mm and a maximum height of 154 mm with a maximum wall thickness of 3.8 mm, closed at the base with a thin cardboard or paperboard disk, plug or cap just sufficient to retain the sample;

A 1.0 mm thick 160 × 160 mm witness plate consisting of steel conforming to specification S235JR (EN10025) or ST37-2 (DIN17100) or SPCC (JIS G 3141) or

equivalent having a stretch limit (or rupture strength) of 185-355 N/mm<sup>2</sup>, an ultimate tensile strength of 336 - 379 N/mm<sup>2</sup> and a percentage elongation after fracture of 26-46% ;

An electric igniter, e.g. a fuse head, with lead wires of at least 30 cm in length;

A mild steel confinement sleeve (weighing approximately 3 kg) having an outside diameter of 63 mm and a minimum length of 165 mm with a flat-bottomed round bore whose interior dimensions for diameter and depth are 38 mm and 155 mm, respectively, and a notch or groove cut into one radius of the open end sufficient to allow the igniter lead wires to pass through (the steel sleeve might be provided with a rugged steel handle for easier handling);

A steel ring of approximately 50 mm height with an inner diameter of 95 mm; and

A solid metal base, e.g. a plate of approximately 25 mm in thickness and 150 mm square.

### **2.3 Procedure**

2.3.1 Prior to testing, the pyrotechnic substance is stored for at least 24 hours in a desiccator at a temperature of 20-30 °C. Twenty-five (25) g net mass of the pyrotechnic substance to be tested as a loose powder or granulated or coated onto any substrate, is pre-weighed and then poured carefully into a fibreboard sample tube with the bottom end closed with a cardboard or paperboard disk, cap or plug. After filling, the top cardboard or paperboard disk, cap or plug might be inserted lightly to protect the sample from spillage during transport to the test stand. The height of the sample substance in the tube will vary depending on its density. The sample should be first consolidated by lightly tapping the tube on a non-sparking surface. The final density of the pyrotechnic substance in the tube should be as close as possible to the density achieved when contained in a fireworks device.

2.3.2 The witness plate is placed on the supporting ring. If present, the paperboard or cardboard top disk, cap or plug of the fibreboard sample tube is removed and the electric igniter is inserted into the top of the pyrotechnic substance to be tested and visually positioned to an approximate depth of 10 mm. The paperboard or cardboard top disk, cap or plug is then inserted or re-inserted, fixing the igniter's position in the fibreboard sample tube and the depth of its match head. The lead wires are bent over and down along the sidewall and bent away at the bottom. The sample tube is placed vertically and centred on the witness plate. The steel sleeve is placed over the fibreboard sample tube. The igniter lead wires are positioned to pass through the slotted groove in the bottom edge of the steel confining sleeve and will be ready to attach to the firing circuit apparatus. Finally, the alignment of the steel sleeve and the witness plate is corrected so that their centres are aligned with the centre of the steel ring. See Figure A7.10 as an example of the test set-up. The cardboard or paperboard disk, cap or plug at the bottom end of the sample tube should be placed properly to avoid air gap between the witness plate and the bottom end of the substance to be tested.

2.3.3 The electric igniter is then initiated from a safe position. After initiation and a suitable interval the witness plate is recovered and examined. The test should be performed 3 times unless a positive result is obtained earlier.

### **2.4 Test criteria and method of assessing results**

The result is considered positive “+” and the pyrotechnic substances in powder form or as pyrotechnic units as presented in the fireworks, that are used in waterfalls, or to produce an aural effect, or used as a bursting charge or lifting charge, is to be considered as flash composition if:

- (a) In any trial the witness plate is torn, perforated, pierced or penetrated; or;



(b) The average of the maximum depths of indented witness plates from all three trials exceeds 15 mm.

#### Examples of results

Composition (mass %)	Use or effect	Observation of witness plate or averaged depth of indentation (mm)	Result
Potassium perchlorate/Aluminium (77/23)	Aural (report)	Pierced	Flash composition
Potassium perchlorate/Barium nitrate/Aluminium/Magnalium (20/20/45/15)	Aural (report)	11.3	Not flash composition
Potassium perchlorate/Potassium benzoate (71/29)	Aural (whistle)	Pierced	Flash composition
Potassium perchlorate/Potassium hydrogen terephthalate /Titanium (62/25/13)	Aural (whistle)	Pierced	Flash composition
Potassium perchlorate/Aluminium (P2000)/Aluminium (P50) (53/16/31)	Waterfall	Pierced	Flash composition
Potassium perchlorate/Aluminium (P2000)/Aluminium (P50)/Antimony sulphide (50/15/30/5)	Waterfall	Pierced	Flash composition
Potassium perchlorate/Charcoal (80/20)	Bursting	Pierced	Flash composition
Potassium perchlorate/Charcoal (60/40)	Bursting	17.7	Flash composition
Potassium perchlorate/Charcoal (50/50)	Bursting	6.7	Not flash composition
Potassium perchlorate/Potassium nitrate /Charcoal (53/26/21)	Bursting	Torn	Flash composition
Potassium perchlorate/Potassium nitrate /Charcoal (53/26/21) (Cottonseed core)	Bursting	12.7	Not flash composition
Potassium perchlorate/Charcoal/Aluminium (59/23/18)	Bursting	Pierced	Flash composition

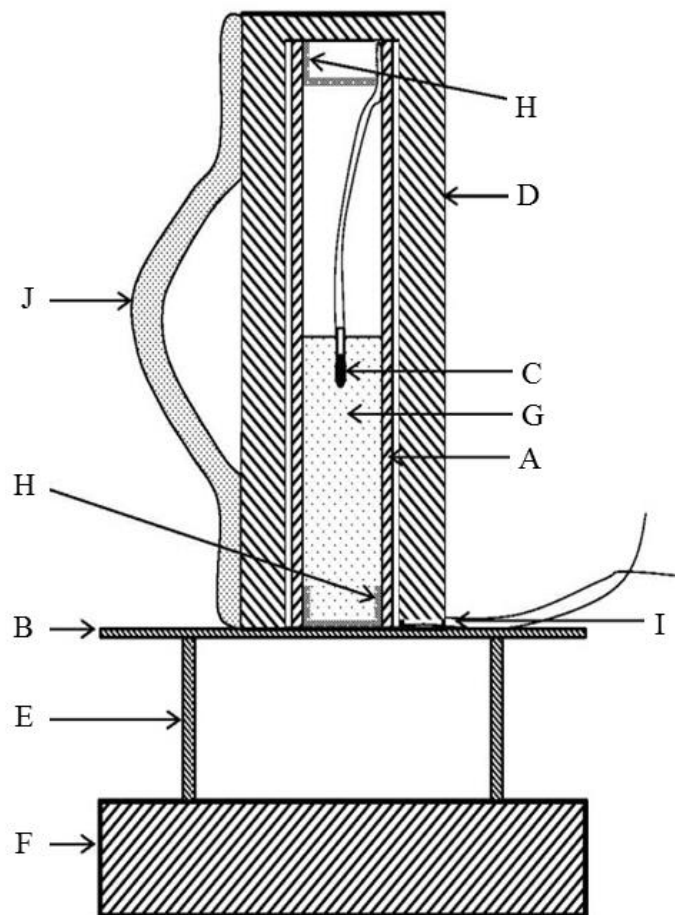

- |   |   |
|---|---|
| (A) Cardboard or fibreboard sample tube | (B) Steel witness plate                       |
| (C) Electric igniter                    | (D) Mild steel confinement sleeve             |
| (E) Steel ring                          | (F) Solid metal base                          |
| (G) Substance to be tested              | (H) Cardboard or paperboard disk, cap or plug |
| (I) Groove in sleeve for igniter wires  | (J) Handle welded on (optional)               |

**Figure A7.10”.**

*(Reference documents: ST/SG/AC.10/C.3/96/Add.1)*

## Part II

### **Draft amendments to the nineteenth revised edition of the Recommendations on the Transport of Dangerous Goods, Model Regulations (ST/SG/AC.10/1/Rev.19)**

#### **Recommendations**

Paragraph 6 In the first sentence, replace “risk” by “hazard”.

Paragraph 11 In the first sentence, replace “risk” by “hazard”.

Paragraph 12 In the first sentence, replace “potential risk” by “[potential] hazard”.

*(Reference document: ST/SG/AC.10/C.3/98/Add.1)*

#### **Chapter 1.3**

1.3.2 (iii) The amendment does not apply to the English version.

*(Reference document: ST/SG/AC.10/C.3/98/Add.1, consequential amendment)*

#### **Chapter 1.4**

1.4.3.1.5 In the first sentence, replace “subsidiary risks” by “subsidiary hazards”.

*(Reference document: ST/SG/AC.10/C.3/98/Add.1)*

[1.4.3.2.1 At the end, insert the following note:

*“NOTE: In addition to the security provisions of these Regulations, competent authorities may implement further security provisions for reasons other than safety of dangerous goods during transport. In order to not impede international and multimodal transport by different explosives security markings, it is recommended that such markings be formatted consistent with an internationally harmonized standard (e.g. European Union Commission Directive 2008/43/EC).”.]*

*(Reference document: ST/SG/AC.10/C.3/98/Add.1)*

#### **Chapter 1.5**

1.5.1.1 The amendment does not apply to the English version.

*(Reference document: ST/SG/AC.10/C.3/98/Add.1, consequential amendment)*

1.5.1.2 The amendment does not apply to the English version.

*(Reference document: ST/SG/AC.10/C.3/98/Add.1, consequential amendment)*

Figure 1, 1.5.2, Replace “subsidiary risk(s)” by “subsidiary hazard(s)”.

*(Reference document: ST/SG/AC.10/C.3/98/Add.1)*

1.5.5.1 In the first sentence, replace “subsidiary risk” by “subsidiary hazard”.

*(Reference document: ST/SG/AC.10/C.3/98/Add.1)*

## Chapter 2.0

2.0.0.2 In the second indent, replace “risk(s)” by “hazard(s)”. The amendment to the second indent does not apply to the English version.

*(Reference document: ST/SG/AC.10/C.3/98/Add.1)*

2.0.1.1 The amendment does not apply to the English version.

*(Reference document: ST/SG/AC.10/C.3/98/Add.1, consequential amendment)*

2.0.1.4 The amendment does not apply to the English version.

*(Reference document: ST/SG/AC.10/C.3/98/Add.1, consequential amendment)*

2.0.1.5 In the end of the last sentence, replace “risk(s)” by “hazard(s)”.

*(Reference document: ST/SG/AC.10/C.3/98/Add.1)*

2.0.1.6 In the end of the last sentence, replace “risk(s)” by “hazard(s)”.

*(Reference document: ST/SG/AC.10/C.3/98/Add.1)*

2.0.2.1 The amendment does not apply to the English version.

*(Reference document: ST/SG/AC.10/C.3/98/Add.1, consequential amendment)*

2.0.2.2 In the second paragraph, replace “risk(s)” by “hazard(s)”.

*(Reference document: ST/SG/AC.10/C.3/98/Add.1)*

2.0.2.5 (c) Replace “risk(s)” by “hazard(s)”.

*(Reference document: ST/SG/AC.10/C.3/98/Add.1)*

2.0.2.9 At the end, replace “risk(s)” by “hazard(s)”.

*(Reference document: ST/SG/AC.10/C.3/98/Add.1)*

2.0.3.1 In the first sentence, replace “one risk” by “one hazard”. In the second sentence, replace “multiple risks” by “multiple hazards”.

*(Reference document: ST/SG/AC.10/C.3/98/Add.1)*

2.0.3.2 In the first sentence, replace “risk” by “hazard”.

*(Reference document: ST/SG/AC.10/C.3/98/Add.1)*

## Chapter 2.1

The amendment to Note 4 after the heading does not apply to the English version.

*(Reference document: ST/SG/AC.10/C.3/98/Add.1, consequential amendment)*

Figure 2.1.1 The amendment does not apply to the English version.

*(Reference document: ST/SG/AC.10/C.3/98/Add.1, consequential amendment)*

2.1.1.1 (a) The amendment does not apply to the English version.

*(Reference document: ST/SG/AC.10/C.3/98/Add.1, consequential amendment)*

2.1.1.4 (a) to (f) The amendment does not apply to the English version.

*(Reference document: ST/SG/AC.10/C.3/98/Add.1, consequential amendment)*

2.1.1.4 (f) In the Note, replace “risk” by “hazard”.

*(Reference document: ST/SG/AC.10/C.3/98/Add.1)*

2.1.2.1 The amendment does not apply to the English version.

*(Reference document: ST/SG/AC.10/C.3/98/Add.1, consequential amendment)*

2.1.2.1.1 In the first column of the table, for Compatibility Group L, replace “risk” by “hazard”.

*(Reference document: ST/SG/AC.10/C.3/98/Add.1)*

2.1.2.1.2 The amendment does not apply to the English version.

*(Reference document: ST/SG/AC.10/C.3/98/Add.1, consequential amendment)*

2.1.3.1.2 (c) In the Note, replace “risk” by “hazard” twice.

*(Reference document: ST/SG/AC.10/C.3/98/Add.1)*

2.1.3.2.1 The amendment does not apply to the English version.

*(Reference document: ST/SG/AC.10/C.3/98/Add.1, consequential amendment)*

2.1.3.3.1 The amendment does not apply to the English version.

*(Reference document: ST/SG/AC.10/C.3/98/Add.1, consequential amendment)*

2.1.3.4 The amendment does not apply to the English version.

*(Reference document: ST/SG/AC.10/C.3/98/Add.1, consequential amendment)*

2.1.3.4.1 The amendment does not apply to the English version.

*(Reference document: ST/SG/AC.10/C.3/98/Add.1, consequential amendment)*

2.1.3.4.2 The amendment does not apply to the English version.

*(Reference document: ST/SG/AC.10/C.3/98/Add.1, consequential amendment)*

2.1.3.5 The amendment does not apply to the English version.

*(Reference document: ST/SG/AC.10/C.3/98/Add.1, consequential amendment)*

2.1.3.5.1 The amendment to the first sentence does not apply to the English version.

*(Reference document: ST/SG/AC.10/C.3/98/Add.1, consequential amendment)*

2.1.3.5.1 (a) Replace “giving a positive result when tested in one of the HSL Flash composition tests in Appendix 7 of the Manual of Tests and Criteria” by “containing flash composition (see Note 2 of 2.1.3.5.5)”.

*(Reference document: ST/SG/AC.10/C.3/96/Add.1)*

2.1.3.5.2 The amendment to Note 2 does not apply to the English version.

*(Reference document: ST/SG/AC.10/C.3/98/Add.1, consequential amendment)*

2.1.3.5.3 The amendment does not apply to the English version.

*(Reference document: ST/SG/AC.10/C.3/98/Add.1, consequential amendment)*

2.1.3.5.5 Amend Note 2 to read as follows:

**“NOTE 2:** “Flash composition” in this table refers to pyrotechnic substances in powder form or as pyrotechnic units as presented in the firework that are used in waterfalls, or to produce an aural effect or used as a bursting charge, or propellant charge unless:

(a) The time taken for the pressure rise in the HSL Flash Composition Test in Appendix 7 of the Manual of Tests and Criteria is demonstrated to be more than 6 ms for 0.5 g of pyrotechnic substance; or

(b) The pyrotechnic substance gives a negative “-” result in the US Flash Composition Test in Appendix 7 of the Manual of Tests and Criteria.”.

*(Reference document: ST/SG/AC.10/C.3/96/Add.1)*

2.1.3.5.5 In the table, amend the entry for “waterfall” as follows: For classification 1.1G, amend the entry under “Specification” to read: “containing flash composition regardless of the results of Test Series 6 (see 2.1.3.5.1 (a))”. For classification 1.3G, amend the entry under “Specification” to read: “not containing flash composition”.

*(Reference document: ST/SG/AC.10/C.3/96/Add.1)*

2.1.3.5.5 The amendment to the entry for “low hazard fireworks and novelties” does not apply to the English version.

*(Reference document: ST/SG/AC.10/C.3/98/Add.1, consequential amendment)*

2.1.3.6.3 In the last sentence, replace “risk(s)” by “hazard(s)”.

*(Reference document: ST/SG/AC.10/C.3/98/Add.1)*

2.1.3.6.4 In Note 2, at the end of the sentence, replace “risk” by “hazard”.

*(Reference document: ST/SG/AC.10/C.3/98/Add.1)*

2.1.3.7.4 (f) The amendment does not apply to the English version.

*(Reference document: ST/SG/AC.10/C.3/98/Add.1, consequential amendment)*

## **Chapter 2.2**

2.2.2.1 The amendment does not apply to the English version.

*(Reference document: ST/SG/AC.10/C.3/98/Add.1, consequential amendment)*

2.2.2.1 (c) In the first sentence, replace “risk” by “hazard”.

*(Reference document: ST/SG/AC.10/C.3/98/Add.1)*

2.2.2.1 (c) (i) The amendment does not apply to the English version.

*(Reference document: ST/SG/AC.10/C.3/98/Add.1, consequential amendment)*

2.2.2.2 The amendment does not apply to the English version.

*(Reference document: ST/SG/AC.10/C.3/98/Add.1, consequential amendment)*

2.2.3 (c) In the first sentence, replace “risk” by “hazard”.

*(Reference document: ST/SG/AC.10/C.3/98/Add.1)*

## Chapter 2.3

2.3.2.1 Replace “risk” by “hazard” (twice).

(Reference document: ST/SG/AC.10/C.3/98/Add.1)

2.3.2.1.1 Replace “risk” by “hazard”.

(Reference document: ST/SG/AC.10/C.3/98/Add.1)

2.3.2.1.2 Replace “risk(s)” by “hazard(s)” twice.

(Reference document: ST/SG/AC.10/C.3/98/Add.1)

## Chapter 2.4

In the Introductory notes, in Note 3, replace “additional subsidiary risk” by “additional subsidiary hazard”.

(Reference document: ST/SG/AC.10/C.3/98/Add.1)

2.4.2.3.2.2 At the end of the paragraph, replace “subsidiary risk(s)” by “subsidiary hazard(s)”.

(Reference document: ST/SG/AC.10/C.3/98/Add.1)

2.4.2.3.2.3 In remark (2) after the table, replace “risk” by “hazard”.

(Reference document: ST/SG/AC.10/C.3/98/Add.1)

2.4.2.3.2.3 At the end of the first paragraph, add a new sentence to read as follows: “The formulations listed in packing instruction IBC520 of 4.1.4.2 and in portable tank instruction T23 of 4.2.5.2.6 may also be transported in packagings of OP8 (see packing instruction P520 of 4.1.4.1), with the same control- and emergency temperatures, if applicable.”.

(Reference document: ST/SG/AC.10/C.3/96/Add.1)

2.4.2.3.2.3 Add a new entry to read as follows:

<i>SELF-REACTIVE SUBSTANCE</i>	<i>Concentration (%)</i>	<i>Packing method</i>	<i>Control temperature (°C)</i>	<i>Emergency temperature (°C)</i>	<i>UN generic entry</i>	<i>Remarks</i>
Phosphorothioic acid, O-[(cyanophenyl methylene) azanyl] O,O-diethyl ester	82-91 (Z isomer)	OP8			3227	(10)

(Reference document: ST/SG/AC.10/C.3/96/Add.1)

After the table, add a new remark (10) to read as follows:

“(10) This entry applies to the technical mixture in n-butanol within the specified concentration limits of the (Z) isomer.”.

(Reference document: ST/SG/AC.10/C.3/96/Add.1)

2.4.2.3.3.2 (b) In the first sentence, replace “risk” by “hazard”.

(Reference document: ST/SG/AC.10/C.3/98/Add.1)

2.4.2.3.3.2 (c) In the first sentence, replace “risk” by “hazard”.

(Reference document: ST/SG/AC.10/C.3/98/Add.1)

2.4.3.1.1 (a) The amendment does not apply to the English version.

(Reference document: ST/SG/AC.10/C.3/98/Add.1, consequential amendment)

## Chapter 2.5

2.5.2.1.2 Replace “risks” by “hazards”.

(Reference document: ST/SG/AC.10/C.3/98/Add.1)

2.5.3.2.3 In the second sentence, replace “risks” by “hazards”.

(Reference document: ST/SG/AC.10/C.3/98/Add.1)

2.5.3.2.4 In the Table header, last column, replace “risks” by “hazards”.

(Reference document: ST/SG/AC.10/C.3/98/Add.1)

2.5.3.2.4 In Table Notes 3, 13, 18 and 27, replace “risk” by “hazard”.

(Reference document: ST/SG/AC.10/C.3/98/Add.1)

2.5.3.2.4 At the end of the first paragraph, add a new sentence to read as follows: «The formulations listed in packing instruction IBC520 of 4.1.4.2 and in portable tank instruction T23 of 4.2.5.2.6 may also be transported in packagings of OP8 (see packing instruction P520 of 4.1.4.1), with the same control- and emergency temperatures, if applicable.».

(Reference document: ST/SG/AC.10/C.3/96/Add.1)

2.5.3.2.4 Insert the following new entries:

<i>Organic peroxide</i>	(2)	(3)	(4)	(5)	(6)	(7)	(8)	(9)	(10)	(11)
DIISOBUTYRYL PEROXIDE	≤ 42 (as a stable dispersion in water)					OP8	-20	-10	3119	
DI-(4-tert-BUTYLCYCLOHEXYL) PEROXYDICARBONATE	≤42 (as a paste)					OP7	35	40	3116	
1-PHENYLETHYL HYDROPEROXIDE	≤38		≥62			OP8			3109	

(Reference document: ST/SG/AC.10/C.3/96/Add.1)

2.5.3.3.2 (b) In the first sentence, replace “risk” by “hazard”.

(Reference document: ST/SG/AC.10/C.3/98/Add.1)

2.5.3.3.2 (c) Replace “risk” by “hazard”.

(Reference document: ST/SG/AC.10/C.3/98/Add.1)

## Chapter 2.6

2.6.2.2.1 The amendment does not apply to the English version.

(Reference document: ST/SG/AC.10/C.3/98/Add.1, consequential amendment)

2.6.2.2.1 (a), (b) and (c) Replace “risk” by “hazard”.

(Reference document: ST/SG/AC.10/C.3/98/Add.1)



2.6.2.4.1 In the second sentence, replace “risks” by “hazards”.

(Reference document: ST/SG/AC.10/C.3/98/Add.1)

2.6.2.4.3 Replace “risks” by “hazards”.

(Reference document: ST/SG/AC.10/C.3/98/Add.1)

## Chapter 2.8

[Amend Chapter 2.8 to read as follows:

“CHAPTER 2.8

CLASS 8 – CORROSIVE SUBSTANCES

### 2.8.1 Definition and general provisions

2.8.1.1 *Corrosive substances* are substances which, by chemical action, will cause irreversible damage to the skin, or, in the case of leakage, will materially damage, or even destroy, other goods or the means of transport.

2.8.1.2 For substances and mixtures that are corrosive to skin, general classification provisions are provided in section 2.8.2. [Skin corrosion refers to the production of irreversible damage to the skin, namely, visible necrosis through the epidermis and into the dermis occurring after exposure to a substance or mixture.] [A substance is corrosive to skin when it leads to the destruction of skin tissue, namely, visible necrosis through the epidermis and into the dermis, in at least one tested animal after exposure for up to 4 hours.]

2.8.1.3 Liquids and solids which may become liquid during transport, which are judged not to be skin corrosive shall still be considered for their potential to cause corrosion to certain metal surfaces in accordance with the criteria in 2.8.3.3 (c) (ii).

### 2.8.2 General classification provisions

2.8.2.1 Substances and mixtures of Class 8 are divided among the three packing groups according to their degree of danger in transport:

- (a) *Packing group I* is assigned to very dangerous substances and mixtures;
- (b) *Packing group II* is assigned to substances and mixtures presenting medium danger;
- (c) *Packing group III* is assigned to substances and mixtures that present minor danger.

2.8.2.2 Allocation of substances listed in the Dangerous Goods List in Chapter 3.2 to the packing groups in Class 8 has been made on the basis of experience taking into account such additional factors as inhalation risk (see 2.8.2.4) and reactivity with water (including the formation of dangerous decomposition products).

2.8.2.3 New substances and mixtures can be assigned to packing groups on the basis of the length of time of contact necessary to produce [full thickness destruction of human skin] in accordance with the criteria in 2.8.3. Alternatively, for mixtures, the criteria in 2.8.4 can be used.

2.8.2.4 A substance or mixture meeting the criteria of Class 8 having an inhalation toxicity of dusts and mists (LC<sub>50</sub>) in the range of packing group I, but toxicity through oral

ingestion or dermal contact only in the range of packing group III or less, shall be allocated to Class 8 (see note under 2.6.2.2.4.1).

### **2.8.3 Packing group assignment for substances and mixtures**

2.8.3.1 Existing human and animal data including information from single or repeated exposure shall be the first line of evaluation, as they give information directly relevant to effects on the skin.

2.8.3.2 In assigning the packing group in accordance with 2.8.2.3, account shall be taken of human experience in instances of accidental exposure. In the absence of human experience the grouping shall be based on data obtained from experiments in accordance with OECD Test Guideline 404<sup>2</sup> or 435<sup>3</sup>. A substance or mixture which is determined not to be corrosive in accordance with OECD Test Guideline 430<sup>4</sup> or 431<sup>5</sup> may be considered not to be corrosive to skin for the purposes of these Regulations without further testing.

2.8.3.3 Packing groups are assigned to corrosive substances in accordance with the following criteria (see table 2.8.3.4):

- (a) Packing group I is assigned to substances that cause [full thickness destruction] of intact skin tissue within an observation period up to 60 minutes starting after the exposure time of three minutes or less;
- (b) Packing group II is assigned to substances that cause [full thickness destruction] of intact skin tissue within an observation period up to 14 days starting after the exposure time of more than three minutes but not more than 60 minutes;
- (c) Packing group III is assigned to substances that:
  - (i) Cause [full thickness destruction] of intact skin tissue within an observation period up to 14 days starting after the exposure time of more than 60 minutes but not more than 4 hours; or
  - (ii) are judged not to cause [full thickness destruction] of intact skin tissue but which exhibit a corrosion rate on either steel or aluminium surfaces exceeding 6.25 mm a year at a test temperature of 55 °C when tested on both materials. For the purposes of testing steel, type S235JR+CR (1.0037 resp. St 37-2), S275J2G3+CR (1.0144 resp. St 44-3), ISO 3574 or Unified Numbering System (UNS) G10200 or a similar type or SAE 1020, and for testing aluminium, non-clad, types 7075-T6 or AZ5GU-T6 shall be used. An acceptable test is prescribed in the Manual of Tests and Criteria, Part III, Section 37.

*NOTE: Where an initial test on either steel or aluminium indicates the substance being tested is corrosive the follow up test on the other metal is not required.*

---

<sup>2</sup> [OECD Guideline for the testing of chemicals No. 404 «Acute Dermal Irritation/Corrosion» 2015]

<sup>3</sup> [OECD Guideline for the testing of chemicals No. 435 «In Vitro Membrane Barrier Test Method for Skin Corrosion» 2015]

<sup>4</sup> [OECD Guideline for the testing of chemicals No. 430 «In Vitro Skin Corrosion: Transcutaneous Electrical Resistance Test (TER)» 2015]

<sup>5</sup> [OECD Guideline for the testing of chemicals No. 431 «In Vitro Skin Corrosion: Human Skin Model Test» 2015]

**Table 2.8.3.4: Table summarizing the criteria in 2.8.3.3**

Packing Group	Exposure Time	Observation Period	Effect
I	< 3 min	≤ 60 min	[full thickness destruction] of intact skin
II	> 3 min ≤ 1 h	≤ 14 d	[full thickness destruction] of intact skin
III	> 1 h ≤ 4 h	≤ 14 d	[full thickness destruction] of intact skin
III	-	-	Corrosion rate on either steel or aluminium surfaces exceeding 6.25 mm a year at a test temperature of 55 °C when tested on both materials

## 2.8.4 Alternative packing group assignment methods for mixtures: Step-wise approach

### 2.8.4.1 General provisions

2.8.4.1.1 For mixtures it is necessary to obtain or derive information that allows the criteria to be applied to the mixture for the purpose of classification and assignment of packing groups. The approach to classification and assignment of packing groups is tiered, and is dependent upon the amount of information available for the mixture itself, for similar mixtures and/or for its ingredients. The flow chart of Figure 2.8.4.1 below outlines the process to be followed:

**Figure 2.8.4.1: Step-wise approach to classify and assign packing group of corrosive mixtures**

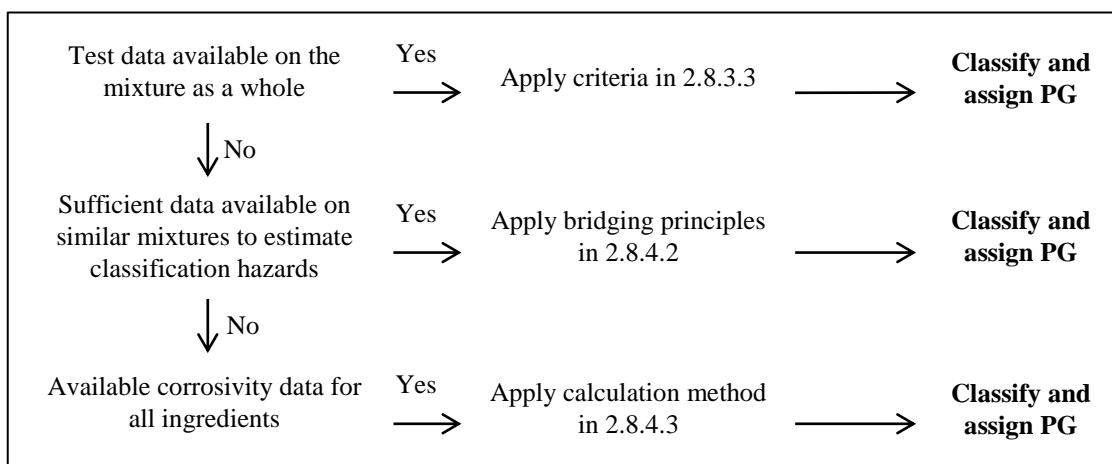

### 2.8.4.2 Bridging principles

2.8.4.2.1 Where a mixture has not been tested to determine its skin corrosion potential, but there are sufficient data on both the individual ingredients and similar tested mixtures to adequately classify and assign a packing group for the mixture, these data will be used in accordance with the following bridging principles. This ensures that the classification process uses the available data to the greatest extent possible in characterizing the hazards of the mixture.

- (a) **Dilution:** If a tested mixture is diluted with a diluent which does not meet the criteria for Class 8 and does not affect the packing group of other ingredients, then the new diluted mixture may be assigned to the same packing group as the original tested mixture.

**NOTE:** in certain cases, diluting a mixture or substance may lead to an increase in the corrosive properties. If this is the case, this bridging principle cannot be used.

(b) **Batching:** The skin corrosion potential of a tested production batch of a mixture can be assumed to be substantially equivalent to that of another untested production batch of the same commercial product when produced by or under the control of the same manufacturer, unless there is reason to believe there is significant variation such that the skin corrosion potential of the untested batch has changed. If the latter occurs, a new classification is necessary.

(c) **Concentration of mixtures of packing group I:** If a tested mixture meeting the criteria for inclusion in packing group I is concentrated, the more concentrated untested mixture may be assigned to packing group I without additional testing.

(d) **Interpolation within one packing group:** For three mixtures (A, B and C) with identical ingredients, where mixtures A and B have been tested and are in the same skin corrosion packing group, and where untested mixture C has the same Class 8 ingredients as mixtures A and B but has concentrations of Class 8 ingredients intermediate to the concentrations in mixtures A and B, then mixture C is assumed to be in the same skin corrosion packing group as A and B.

(e) **Substantially similar mixtures:** Given the following:

- (i) Two mixtures: (A+B) and (C+B);
- (ii) The concentration of ingredient B is the same in both mixtures;
- (iii) The concentration of ingredient A in mixture (A+B) equals the concentration of ingredient C in mixture (C+B);
- (iv) Data on skin corrosion for A and C are available and substantially equivalent, i.e. they are the same skin corrosion packing group and do not affect the skin corrosion potential of B.

If mixture (A+B) or (C+B) is already classified based on test data, then the other mixture may be assigned to the same packing group.

#### 2.8.4.3 *Calculation method based on the classification of the substances*

2.8.4.3.1 Where a mixture has not been tested to determine its skin corrosion potential, nor is sufficient data available on similar mixtures, the corrosive properties of the substances in the mixture shall be considered to classify and assign a packing group. This is possible when all substances in the mixture (i.e. present in concentrations of >1%) are considered for classification in accordance with [Chapter 2].

Applying the calculation method is only allowed if there are no synergistic effects that make the mixture more corrosive than the sum of its substances. This restriction applies only if packing group II or III would be assigned to the mixture.

2.8.4.3.2 When using the calculation method, all Class 8 ingredients present at a concentration of  $\geq 1\%$  shall be taken into account, or  $<1\%$  if these ingredients are still relevant for classifying the mixture to be corrosive to skin.

2.8.4.3.3 To determine whether a mixture containing corrosive substances shall be considered a corrosive mixture and to assign a packing group, the calculation method in the flow chart in Figure 2.8.4.3 shall be applied. When a specific concentration limit is

assigned to a substance following its entry in the Dangerous Goods List or in a Special Provision, this limit shall be used instead of the generic limits in Figure 2.8.4.3. for that substance.

[insert example/explanation on specific concentration limits here]

**Figure 2.8.4.3: Calculation method**

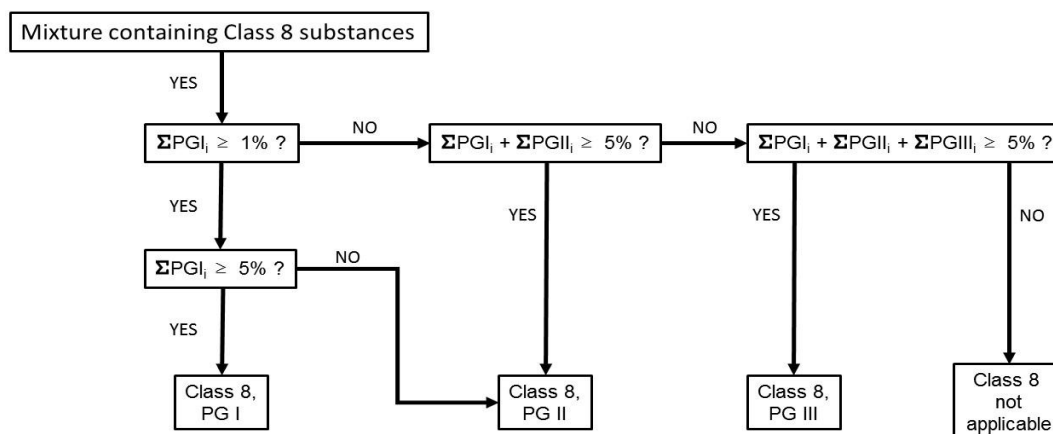

### 2.8.5 Substances not accepted for transport

Chemically unstable substances of Class 8 shall not be accepted for transport unless the necessary precautions have been taken to prevent the possibility of a dangerous decomposition or polymerization under normal conditions of transport. For the precautions necessary to prevent polymerization, see special provision 386 of Chapter 3.3. To this end particular care shall be taken to ensure that receptacles and tanks do not contain any substances liable to promote these reactions.]

(Reference document: ST/SG/AC.10/C.3/98/Add.1)

## Chapter 2.9

2.9.2 The amendment does not apply to the English version.

(Reference document: ST/SG/AC.10/C.3/98/Add.1, consequential amendment)

2.9.4 Add the following new paragraph f):

“f) lithium batteries, containing both primary lithium metal cells and rechargeable lithium ion cells, that are not designed to be externally charged (see special provision 387 of Chapter 3.3) shall meet the following conditions:

- i) The rechargeable lithium ion cells can only be charged from the primary lithium metal cells;
- ii) Overcharge of the rechargeable lithium ion cells is precluded by design;
- iii) The battery has been tested as a lithium primary battery;

iv) Component cells of the battery shall be of a type proved to meet the respective testing requirements of the Manual of Tests and Criteria, part III, sub-section 38.3.”.

(Reference document: ST/SG/AC.10/C.3/98/Add.1)

### Chapter 3.1

3.1.1.2 At the end of the last sentence, replace “risks” by “hazards”.

(Reference document: ST/SG/AC.10/C.3/98/Add.1)

3.1.2.8.1.1 The amendment does not apply to the English version.

(Reference document: ST/SG/AC.10/C.3/98/Add.1, consequential amendment)

3.1.2.8.1.2 In the last sentence, replace “risk” by “hazard” (twice).

(Reference document: ST/SG/AC.10/C.3/98/Add.1)

3.1.3.2 Amend the first sentence to read as follows: “When a combination of several distinct proper shipping names are listed under a single UN number, and these are separated by “and” or ”or” in lower case or are punctuated by commas, only the most appropriate shall be shown in the transport document or package marks.”.

Delete the second sentence.

(Reference document: ST/SG/AC.10/C.3/98/Add.1)

3.1.3.2 (c) Replace “risk(s)” by “hazard(s)”.

(Reference document: ST/SG/AC.10/C.3/98/Add.1)

3.1.3.3 Replace “subsidiary risk(s)” by “subsidiary hazard(s)”.

(Reference document: ST/SG/AC.10/C.3/98/Add.1)

### Chapter 3.2

3.2.1 In the description of Column 4, replace “risk” by “hazard” and “risks” by “hazards”.

(Reference document: ST/SG/AC.10/C.3/98/Add.1)

#### Dangerous goods list

For the heading of column 4, replace “risk” by “hazard”.

(Reference document: ST/SG/AC.10/C.3/98/Add.1)

For UN Nos. 0349, 0367, 0384 and 0481, insert “347” in Column 6.

(Reference document: ST/SG/AC.10/C.3/98/Add.1)

For UN Nos. 1363, 1386, 1398, 1435, 2071, 2216, 2217 and 2793, in column (10), insert “BK2”

(Reference document: ST/SG/AC.10/C.3/96/Add.1)

For UN 1945, in Column (6), add “293”.

(Reference document: ST/SG/AC.10/C.3/98/Add.1)

For UN Nos. 3090, 3091, 3480 and 3481, in column (6) insert “387”.

(Reference document: ST/SG/AC.10/C.3/96/Add.1)

For UN 3166, delete “312”, “380” and “385” in Column (6).

(Reference document: ST/SG/AC.10/C.3/98/Add.1)

For UN 3166 and UN 3171, insert “388” in Column (6).

(Reference document: ST/SG/AC.10/C.3/98/Add.1)

For UN 3171, delete “240” in Column (6).

(Reference document: ST/SG/AC.10/C.3/98/Add.1)

For UN 3302 in column (2) add at the end of the designation “, STABILIZED” and in Column (6), add “386”.

(Reference document: ST/SG/AC.10/C.3/98/Add.1)

For UN No. 3316, delete the entry corresponding to packing group III. In the remaining entry, in column (5), delete “II”.

(Reference document: ST/SG/AC.10/C.3/96/Add.1)

Add the following new entries:

(1)	(2)	(3)	(4)	(5)	(6)	(7a)	(7b)	(8)	(9)	(10)	(11)
3535	TOXIC SOLID, FLAMMABLE, INORGANIC, N.O.S.	6.1	4.1	I	274	0	E5	P002 IBC99		T6	TP33
3535	TOXIC SOLID, FLAMMABLE, INORGANIC, N.O.S.	6.1	4.1	II	274	500 g	E4	P002 IBC08	B2, B4	T3	TP33
3536	LITHIUM BATTERIES INSTALLED IN CARGO TRANSPORT UNIT lithium ion batteries or lithium metal batteries	9			389	E0	0				

(Reference documents: ST/SG/AC.10/C.3/96/Add.1 and ST/SG/AC.10/C.3/98/Add.1)

## Alphabetical Index

In column “Name and description” of the Alphabetical Index of Substances and Articles for the entry “2-DIMETHYLAMINOETHYL ACRYLATE” add at the end “, STABILIZED”.

(Reference document: ST/SG/AC.10/C.3/98/Add.1)

Add the following new entries:

TOXIC SOLID, FLAMMABLE, INORGANIC, N.O.S.	6.1	3535
LITHIUM BATTERIES INSTALLED IN CARGO TRANSPORT UNIT lithium ion batteries or lithium metal batteries	9	3536

(Consequential amendment)

### Chapter 3.3

Special provision 23           The amendment does not apply to the English version.

*(Reference document: ST/SG/AC.10/C.3/98/Add.1, consequential amendment)*

Special provision 61           The amendment does not apply to the English version.

*(Reference document: ST/SG/AC.10/C.3/98/Add.1, consequential amendment)*

Special provision 63           In the introductory text, replace “risk(s)” by “hazard(s)”. In (e) and (g), replace “risk” by “hazard”.

*(Reference document: ST/SG/AC.10/C.3/98/Add.1)*

Special provision 122          Replace “risk(s)” by “hazard(s)”.

*(Reference document: ST/SG/AC.10/C.3/98/Add.1)*

Special provision 133          Replace “risk” by “hazard”.

*(Reference document: ST/SG/AC.10/C.3/98/Add.1)*

Special provision 172          In (a) and (b), replace “risk” by “hazard” 3 times. In (c), replace “risk(s)” by “hazard(s)”.

*(Reference document: ST/SG/AC.10/C.3/98/Add.1)*

Special provision 181          Replace “risk” by “hazard”.

*(Reference document: ST/SG/AC.10/C.3/98/Add.1)*

Special provision 188 (d)      Replace “protection against contact with conductive materials” by “protection against contact with electrically conductive material”.

*(Reference document: ST/SG/AC.10/C.3/98/Add.1)*

Special provision 188 (f)      At the end, add two new sentences to read as follows: «When packages are placed in an overpack, the lithium battery mark shall either be clearly visible or be reproduced on the outside of the overpack and the overpack shall be marked with the word “OVERPACK”. The lettering of the “OVERPACK” mark shall be at least 12 mm high.».

Existing note becomes Note 1. Add the following new Note 2:

**“NOTE 2:** *Packages containing lithium batteries packed in conformity with the provisions of Part 4, Chapter 11, packing instructions 965 or 968, Section IB of the ICAO Technical Instructions for the Safe Transport of Dangerous Goods by Air that bear the mark as shown in 5.2.1.9 (lithium battery mark) and the label shown in 5.2.2.2.2, Model No.9A shall be deemed to meet the provisions of this special provision.”.*

*(Reference document: ST/SG/AC.10/C.3/96/Add.1 and ST/SG/AC.10/C.3/98/Add.1)*

Special provision 188 (i)      At the end of the second paragraph, add the following sentence: «As used in this special provision “equipment” means apparatus for which the lithium cells or batteries will provide electrical power for its operation.».

*(Reference document: ST/SG/AC.10/C.3/96/Add.1)*

Special provision 199          The amendment does not apply to the English version.

*(Reference document: ST/SG/AC.10/C.3/98/Add.1, consequential amendment)*

Special provision 204          Replace “risk” by “hazard” three times.

*(Reference document: ST/SG/AC.10/C.3/98/Add.1)*



Delete special provisions 240, 312, 380 and 385 and add:

“240 *(Deleted)*”

“312 *(Deleted)*”

“380 *(Deleted)*”

“385 *(Deleted)*”

*(Reference document: ST/SG/AC.10/C.3/98/Add.1)*

Special provision 251 In the first paragraph, replace the last sentence by:

“Such kits shall only contain dangerous goods that are permitted as:

- (a) Excepted quantities not exceeding the quantity indicated by the code in column (7b) of the Dangerous Goods List of Chapter 3.2, provided that the net quantity per inner packaging and net quantity per package are as prescribed in 3.5.1.2 and 3.5.1.3; or;
- (b) Limited quantities as indicated in column (7a) of the Dangerous Goods List of Chapter 3.2, provided that the net quantity per inner packaging does not exceed 250 ml or 250 g.”.

In the second paragraph, delete the last sentence.

In the third paragraph, insert a first sentence to read as follows:

“For the purposes of completion of the dangerous goods transport document as set out in 5.4.1.4.1, the packing group shown on the document shall be the most stringent packing group assigned to any individual substance in the kit.”.

*(Reference document: ST/SG/AC.10/C.3/96/Add.1)*

Special provision 271 Replace “risk” by “hazard”.

*(Reference document: ST/SG/AC.10/C.3/98/Add.1)*

Special provision 280 The amendment does not apply to the English version.

*(Reference document: ST/SG/AC.10/C.3/98/Add.1, consequential amendment)*

Special Provision 290 (b) In (a) and (b), replace “risk” by “hazard”.

*(Reference document: ST/SG/AC.10/C.3/98/Add.1)*

Special Provision 293 (b) After “Safety matches are”, insert “matches that”.

*(Reference document: ST/SG/AC.10/C.3/98/Add.1)*

Special provision 296 The amendment does not apply to the English version.

*(Reference document: ST/SG/AC.10/C.3/98/Add.1, consequential amendment)*

Special provision 303 The amendment does not apply to the English version.

*(Reference document: ST/SG/AC.10/C.3/98/Add.1, consequential amendment)*

Special provision 310 In the first paragraph, replace “cells and batteries” by “cells or batteries”, twice.

*(Reference document: ST/SG/AC.10/C.3/94)*

Special Provision 339 (b) The amendment does not apply to the English version.

*(Reference document: ST/SG/AC.10/C.3/98/Add.1, consequential amendment)*

Special Provision 361 (b) The amendment does not apply to the English version.

*(Reference document: ST/SG/AC.10/C.3/98/Add.1, consequential amendment)*

Special provision 362 (b) Replace “risk” by “hazard”.

*(Reference document: ST/SG/AC.10/C.3/98/Add.1)*

Special provision 362 (c) Replace “risk” by “hazard”.

*(Reference document: ST/SG/AC.10/C.3/98/Add.1)*

Special provision 363 Add the following new introductory sentence: “This entry may only be used when the conditions of this special provision are met. No other requirements of these Regulations apply.”.

*(Reference document: ST/SG/AC.10/C.3/98/Add.1)*

Special provision 363 (f) Replace the last sentence by the following text:

“However, lithium batteries shall meet the provisions of 2.9.4, except that 2.9.4 (a) does not apply when pre-production prototype batteries or batteries of a small production run, consisting of not more than 100 batteries, are installed in machinery or engines.

Where a lithium battery installed in a machinery or an engine is damaged or defective, the machinery or engine shall be transported as defined by the competent authority.”.

*(Reference document: ST/SG/AC.10/C.3/98/Add.1)*

Special provision 363 Delete the first sub-paragraph under (g). Renumber existing (i) to (vi) under current (g) as (g) to (l). Add a new sub-paragraph (m) to read as follows:

“(m) The requirements specified in packing instruction P005 of 4.1.4.1 shall be met.”.

*(Reference document: ST/SG/AC.10/C.3/98/Add.1)*

Special Provision 369 In the first paragraph, replace “risks” by “hazards”. In the third paragraph, replace “risk” by “hazard”.

*(Reference document: ST/SG/AC.10/C.3/98/Add.1)*

3.3.1 Add the following new special provisions:

“387 Lithium batteries in conformity with 2.9.4 (f) containing both primary lithium metal cells and rechargeable lithium ion cells shall be assigned to UN Nos. 3090 or 3091 as appropriate. When such batteries are transported in accordance with special provision 188, the total lithium content of all lithium metal cells contained in the battery shall not exceed 1.5 g and the total capacity of all lithium ion cells contained in the battery shall not exceed 10 Wh.”.

*(Reference document: ST/SG/AC.10/C.3/98/Add.1)*

“388 Entry UN 3166 applies to vehicles powered by flammable liquid or gas internal combustion engines or fuel cells.

Vehicles powered by a fuel cell engine shall be consigned under the entries UN No. 3166 VEHICLE, FUEL CELL, FLAMMABLE GAS POWERED or UN No. 3166 VEHICLE, FUEL CELL, FLAMMABLE LIQUID POWERED, as appropriate. These entries include hybrid electric vehicles powered by both a fuel cell and an internal combustion engine with wet batteries, sodium batteries, lithium metal batteries or lithium ion batteries, transported with the battery(ies) installed.

Other vehicles which contain an internal combustion engine shall be consigned under the entries UN 3166 VEHICLE, FLAMMABLE GAS POWERED or UN 3166 VEHICLE, FLAMMABLE LIQUID POWERED, as appropriate. These entries include hybrid electric vehicles powered by both an internal combustion engine and wet batteries, sodium

batteries, lithium metal batteries or lithium ion batteries, transported with the battery(ies) installed.

If a vehicle is powered by a flammable liquid and a flammable gas internal combustion engine, it shall be assigned to UN 3166 VEHICLE, FLAMMABLE GAS POWERED.

Entry UN 3171 only applies to vehicles powered by wet batteries, sodium batteries, lithium metal batteries or lithium ion batteries and equipment powered by wet batteries or sodium batteries transported with these batteries installed.

For the purpose of this special provision, vehicles are self-propelled apparatus designed to carry one or more persons or goods. Examples of such vehicles are cars, motorcycles, scooters, three- and four-wheeled vehicles or motorcycles, trucks, locomotives, bicycles (pedal cycles with a motor) and other vehicles of this type (e.g. self-balancing vehicles or vehicles not equipped with at least one seating position), wheelchairs, lawn tractors, self-propelled farming and construction equipment, boats and aircraft. This includes vehicles transported in a packaging. In this case some parts of the vehicle may be detached from its frame to fit into the packaging.

Examples of equipment are lawnmowers, cleaning machines or model boats and model aircraft. Equipment powered by lithium metal batteries or lithium ion batteries shall be consigned under the entries UN 3091 LITHIUM METAL BATTERIES CONTAINED IN EQUIPMENT or UN 3091 LITHIUM METAL BATTERIES PACKED WITH EQUIPMENT or UN 3481 LITHIUM ION BATTERIES CONTAINED IN EQUIPMENT or UN 3481 LITHIUM ION BATTERIES PACKED WITH EQUIPMENT, as appropriate.

Dangerous goods, such as batteries, airbags, fire extinguishers, compressed gas accumulators, safety devices and other integral components of the vehicle that are necessary for the operation of the vehicle or for the safety of its operator or passengers, shall be securely installed in the vehicle and are not otherwise subject to these Regulations. However, lithium batteries shall meet the provisions of 2.9.4, except that 2.9.4 (a) does not apply when pre-production prototype batteries or batteries of a small production run, consisting of not more than 100 batteries, are installed in vehicles or equipment.

Where a lithium battery installed in a vehicle or equipment is damaged or defective, the vehicle or equipment shall be transported as defined by the competent authority.”.

*(Reference document: ST/SG/AC.10/C.3/98/Add.1)*

“389 This entry only applies to lithium ion batteries or lithium metal batteries installed in a cargo transport unit and designed only to provide power external to the cargo transport unit. The lithium batteries shall meet the requirements of 2.9.4 (a) to (e) and contain the necessary systems to prevent overcharge and over discharge between the batteries.

The batteries shall be securely attached to the interior structure of the cargo transport unit (e.g., by means of placement in racks, cabinets, etc.) in such a manner as to prevent short circuits, accidental operation, and significant movement relative to the cargo transport unit under the shocks, loadings and vibrations normally incident to transport. Dangerous goods necessary for the safe and proper operation of the cargo transport unit (e.g., fire extinguishing systems and air conditioning systems), shall be properly secured to or installed in the cargo transport unit and are not otherwise subject to these Regulations. Dangerous goods not necessary for the safe and proper operation of the cargo transport unit shall not be transported within the cargo transport unit.

The batteries inside the cargo transport unit are not subject to marking or labelling requirements. The cargo transport unit shall display the UN number in accordance with 5.3.2.1.2 and be placarded on two opposing sides in accordance with 5.3.1.1.2.”.

*(Reference document: ST/SG/AC.10/C.3/98/Add.1)*

## Chapter 3.5

3.5.4.1 The amendment does not apply to the English version.

*(Reference document: ST/SG/AC.10/C.3/98/Add.1, consequential amendment)*

## Appendix A

In the List of generic and N.O.S. proper shipping names, header, column 2, replace “risk” by “hazard”.

*(Reference document: ST/SG/AC.10/C.3/98/Add.1)*

## Appendix B

In the definition of “Initiation, means of”, in (2), replace “significant risk” by “significant hazard”.

The other amendments do not apply to the English text.

*(Reference document: ST/SG/AC.10/C.3/98/Add.1, consequential amendment)*

## Chapter 4.1

4.1.1.11 The amendment does not apply to the English version.

*(Reference document: ST/SG/AC.10/C.3/98/Add.1, consequential amendment)*

4.1.4.1, packing instruction P101 Replace “The State’s distinguishing sign for motor vehicles in international traffic” by “The distinguishing sign used on vehicles in international road traffic<sup>a</sup>”.

Table note a reads as follows:

<sup>a</sup> *Distinguishing sign of the State of registration used on motor vehicles and trailers in international road traffic, e.g. in accordance with the Geneva Convention on Road Traffic of 1949 or the Vienna Convention on Road Traffic of 1968.”.*

*(Reference document: ST/SG/AC.10/C.3/98/Add.1)*

4.1.4.1, packing instruction P200 In the header of column 4 of tables 1, 2 and 3, replace “risk” by “hazard”.

*(Reference document: ST/SG/AC.10/C.3/98/Add.1)*

4.1.4.1, packing instruction P200, paragraph (3) (e), amend as follows:

In the first paragraph, replace “liquid phase” by “liquefied gas”.

In subparagraph (i), replace “liquid component” by “liquefied gas”.

In subparagraph (iv), replace “liquid component” by “liquefied gas”.

In subparagraph (v), replace “liquid component” by “liquefied gas”.

In the last paragraph, replace “liquid component” by “liquid phase”.

*(Reference document: ST/SG/AC.10/C.3/96/Add.1)*

4.1.4.1, packing instruction P203, (7) Replace “risk” by “hazard”.

*(Reference document: ST/SG/AC.10/C.3/98/Add.1)*

4.1.4.1, packing instruction P206 (3)

In the first paragraph, replace “liquid phase” by “liquefied gas”.

In subparagraph (i), replace “liquid component” by “liquefied gas”.

In subparagraph (iv), replace “liquid component” by “liquefied gas”.

In subparagraph (v), replace “liquid component” by “liquefied gas”.

In the last paragraph, replace “liquid component” by “liquid phase”.

*(Reference document: ST/SG/AC.10/C.3/98/Add.1)*

4.1.4.1, packing instruction P208 In Table 1, header, column 4, replace “risk” by “hazard”.

*(Reference document: ST/SG/AC.10/C.3/98/Add.1)*

4.1.4.1, packing instruction P520, additional requirement 4 Replace “risk” by “hazard”.

*(Reference document:*

4.1.4.1, packing instruction P801, additional requirement 2 Replace “non-conductive” by “electrically non-conductive”.

*(Reference document: ST/SG/AC.10/C.3/98/Add.1)*

4.1.4.1, packing instruction P901 Under “Additional requirements”, delete “not exceed either 250 ml or 250 g and shall”.

*(Reference document: ST/SG/AC.10/C.3/96/Add.1)*

4.1.4.1, packing instruction P903 Before the introductory sentence that starts «The following packagings...», insert a new sentence to read as follows: «For the purpose of this packing instruction, “equipment” means apparatus for which the lithium cells or batteries will provide electrical power for its operation.».

*(Reference document: ST/SG/AC.10/C.3/96/Add.1)*

4.1.4.1, packing instruction P903 (3) Delete the last sentence.

*(Reference document: ST/SG/AC.10/C.3/96/Add.1)*

4.1.4.1, packing instruction P906 (2) Replace “devices” by “articles”.

*(Reference document: ST/SG/AC.10/C.3/96/Add.1)*

4.1.4.1, packing instruction P908 In paragraphs 2 and 4, replace “non-conductive” by “electrically non-conductive”.

*(Reference document: ST/SG/AC.10/C.3/98/Add.1)*

4.1.4.1, packing instruction P909 In paragraphs 1 (c) and 2 (b), in the fourth indent of additional requirement 2 and in additional requirement 3, replace “non-conductive” by “electrically non-conductive”.

*(Reference document: ST/SG/AC.10/C.3/98/Add.1)*

4.1.4.1, packing instruction P910 In paragraphs (1) (c), (1) (d), (2) (c), and fourth indent of the additional requirements, replace “non-conductive” by “electrically non-conductive”.

*(Reference document: ST/SG/AC.10/C.3/98/Add.1)*

4.1.4.1, packing instruction P910 In the introductory sentence, replace “cells and batteries” by “cells or batteries”, twice.

(Reference document: ST/SG/AC.10/C.3/94)

4.1.4.2, packing instruction IBC520 In the second line, after «4.1.7.2.», insert a new sentence to read as follows: «The formulations listed below may also be transported in packagings of OP8 (see packing instruction P520 of 4.1.4.1), with the same control- and emergency temperatures, if applicable.».

(Reference document: ST/SG/AC.10/C.3/96/Add.1)

4.1.4.2, packing instruction IBC520 For UN No. 3109, under the entry «tert-Butyl hydroperoxide, not more than 72% solution with water», add a new line to read:

Type of IBC	Maximum quantity (litres)	Control temperature	Emergency Temperature
31HA1	1 000		

(Reference document: ST/SG/AC.10/C.3/96/Add.1)

4.1.4.2, packing instruction IBC 520 Add the following new entries:

UN No.	Organic peroxide	Type of IBC	Maximum quantity (litres)	Control temperature	Emergency Temperature
3109	2,5-Dimethyl-2,5-di(tert-butylperoxy)hexane, not more than 52% in diluent type A	31HA1	1000		
3109	3,6,9-Triethyl-3,6,9-trimethyl-1,4,7-triperoxonane not more than 27% in a diluent type A	31HA1	1000		
3119	tert-Amyl peroxy-2-ethylhexanoate, not more than 62% in a diluent type A	31HA1	1000	+15 C	+20 C

(Reference document: ST/SG/AC.10/C.3/96/Add.1)

4.1.4.3, packing instruction LP902 Under “Packaged articles”, replace “Packagings conforming to the packing group III performance level.” by:

“Rigid large packagings conforming to the packing group III performance level, made of:

- steel (50A)
- aluminium (50B)
- metal other than steel or aluminium (50N)
- rigid plastics (50H)
- natural wood (50C)
- plywood (50D)
- reconstituted wood (50F)
- rigid fibreboard (50G)”.

(Reference document: ST/SG/AC.10/C.3/98/Add.1)

4.1.4.3, packing instruction LP904 In paragraphs 2 and 4, replace “non-conductive” by “electrically non-conductive”.

(Reference document: ST/SG/AC.10/C.3/98/Add.1)

4.1.5.12 The amendment does not apply to the English version.

(Reference document: ST/SG/AC.10/C.3/98/Add.1, consequential amendment)

4.1.6.1.4 In the third sentence, replace “risk” by “hazard”.

(Reference document: ST/SG/AC.10/C.3/98/Add.1)

4.1.8.1 The amendment does not apply to the English version.

(Reference document: ST/SG/AC.10/C.3/98/Add.1, consequential amendment)

4.1.9.1.5 Replace “risk” by “hazard” (twice).

(Reference document: ST/SG/AC.10/C.3/98/Add.1)

## Chapter 4.2

4.2.1.19.1 Replace “risk” by “hazard”.

(Reference document: ST/SG/AC.10/C.3/98/Add.1)

4.2.5.2.6, Portable tank instruction T23 In the first line after the title, add a new sentence to read as follows: «The formulations listed below may also be transported in packagings of OP8 (see packing instruction P520 of 4.1.4.1), with the same control and emergency temperatures, if applicable.».

(Reference document: ST/SG/AC.10/C.3/96/Add.1)

4.2.5.2.6, Portable tank instruction T23, footnote (d) Replace “risk” by “hazard”.

(Reference document: ST/SG/AC.10/C.3/98/Add.1)

## Chapter 4.3

4.3.1.12 The amendment does not apply to the English version.

(Reference document: ST/SG/AC.10/C.3/98/Add.1, consequential amendment)

## Chapter 5.1

5.1.1 At the end, add the following Note:

**“NOTE:** In accordance with the GHS, a GHS pictogram not required by these Regulations should only appear in transport as part of a complete GHS label and not independently (see GHS 1.4.10.4.4).”.

(Reference document: ST/SG/AC.10/C.3/96/Add.1)

5.1.4 Replace “risk” by “hazard” twice.

(Reference document: ST/SG/AC.10/C.3/98/Add.1)

## Chapter 5.2

5.2.2.1.1 Replace “risks” by “hazards” and “risk” by “hazard”.

(Reference document: ST/SG/AC.10/C.3/98/Add.1)

5.2.2.1.2 Replace “risk” by “hazard” 6 times.

(Reference document: ST/SG/AC.10/C.3/98/Add.1)

5.2.2.1.3 Replace “risk” by “hazard” 3 times.

*(Reference document: ST/SG/AC.10/C.3/98/Add.1)*

5.2.2.1.3.1 Replace “risk” by “hazard” twice.

*(Reference document: ST/SG/AC.10/C.3/98/Add.1)*

5.2.2.1.4 Replace “risk(s)” by “hazard(s)” 2 times and “risk” by “hazard” (twice).

*(Reference document: ST/SG/AC.10/C.3/98/Add.1)*

5.2.2.1.5 Replace “risk” by “hazard”.

*(Reference document: ST/SG/AC.10/C.3/98/Add.1)*

5.2.2.1.6 (c) Replace “risk” by “hazard”.

*(Reference document: ST/SG/AC.10/C.3/98/Add.1)*

5.2.2.1.9 Replace “risk” by “hazard”.

*(Reference document: ST/SG/AC.10/C.3/98/Add.1)*

5.2.2.1.10 Replace “risk” by “hazard” 4 times.

*(Reference document: ST/SG/AC.10/C.3/98/Add.1)*

5.2.2.1.11 Replace “risk” by “hazard”.

*(Reference document: ST/SG/AC.10/C.3/98/Add.1)*

5.2.2.2.1.1.3 In the first sentence, after “the dimensions may be reduced” add “proportionally”. Delete the second and third sentences (“The line inside the edge shall remain 5 mm to the edge of the label. The minimum width of the line inside the edge shall remain 2 mm.”).

*(Reference document: ST/SG/AC.10/C.3/96/Add.1)*

5.2.2.2.1.2 In the first sentence, insert ““Gas cylinders – Precautionary labels”” after “ISO 7225:2005” and delete it in the second sentence.

*(Reference document: ST/SG/AC.10/C.3/98/Add.1, consequential amendment)*

5.2.2.2.1.3 The amendment does not apply to the English version.

*(Reference document: ST/SG/AC.10/C.3/98/Add.1, consequential amendment)*





5.2.2.2.1.5 Replace “risk” by “hazard”.



*(Reference document: ST/SG/AC.10/C.3/98/Add.1)*



5.2.2.2.2 Amend to read as follows:



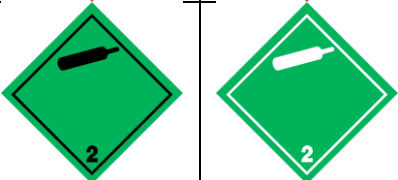

“5.2.2.2.2 Specimen labels



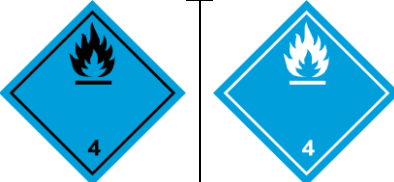





Label model No.	Division or Category	Symbol and symbol colour	Background	Figure in bottom corner (and figure colour)	Specimen labels	Note
<b>Class 1: Explosive substances or articles</b>						
1	Divisions 1.1, 1.2, 1.3	Exploding bomb: black	Orange	1 (black)		** Place for division – to be left blank if explosive is the subsidiary hazard * Place for compatibility group – to be left blank if explosive is the subsidiary hazard
1.4	Division 1.4	1.4: black Numerals shall be about 30 mm in height and be about 5 mm thick (for a label measuring 100 mm × 100 mm)	Orange	1 (black)		* Place for compatibility group
1.5	Division 1.5	1.5: black Numerals shall be about 30 mm in height and be about 5 mm thick (for a label measuring 100 mm × 100 mm)	Orange	1 (black)		* Place for compatibility group
1.6	Division 1.6	1.6: black Numerals shall be about 30 mm in height and be about 5 mm thick (for a label measuring 100 mm × 100 mm)	Orange	1 (black)		* Place for compatibility group

Label model No.	Division or Category	Symbol and symbol colour	Background	Figure in bottom corner (and figure colour)	Specimen labels	Note
<b>Class 2: Gases</b>						
2.1	Division 2.1: Flammable gases (except as provided for in 5.2.2.2.1.6 d))	Flame: black or white	Red	2 (black or white)		-
2.2	Division 2.2: Non-flammable, non-toxic gases	Gas cylinder: black or white	Green	2 (black or white)		-
2.3	Division 2.3: Toxic gases	Skull and crossbones: black	White	2 (black)		-

Label model No.	Division or Category	Symbol and symbol colour	Background	Figure in bottom corner (and figure colour)	Specimen labels	Note
<b>Class 3: Flammable liquids</b>						
3	-	Flame: black or white	Red	3 (black or white)		-
<b>Class 4</b>						
4.1	Division 4.1: Flammable solids, self-reactive substances, solid desensitized explosives and polymerizing substances	Flame: black	White with 7 vertical red stripes	4 (black)		-
4.2	Division 4.2: Substances liable to spontaneous combustion	Flame: black	Upper half white, lower half red	4 (black)		-
4.3	Division 4.3: Substances which, in contact with water emit flammable gases	Flame: black or white	Blue	4 (black or white)		-

Label model No.	Division or Category	Symbol and symbol colour	Background	Figure in bottom corner (and figure colour)	Specimen labels	Note
<b>Class 5</b>						
5.1	Division 5.1: Oxidizing substances	Flame over circle: black	Yellow	5.1 (black)		-
5.2	Division 5.2: Organic peroxides	Flame: black or white	Upper half red, lower half yellow	5.2 (black)		-
<b>Class 6</b>						
6.1	Division 6.1: Toxic substances	Skull and crossbones: black	White	6 (black)		-
6.2	Division 6.2: Infectious substances	Three crescents superimposed on a circle: black	White	6 (black)		The lower half of the label may bear the inscriptions: "INFECTIOUS SUBSTANCE" and "In the case of damage or leakage immediately notify Public Health Authority" in black colour

Label model No.	Division or Category	Symbol and symbol colour	Background	Figure in bottom corner (and figure colour)	Specimen labels	Note
<b>Class 7: Radioactive material</b>						
7A	Category I	Trefoil: black	White	7 (black)		Text (mandatory), black in lower half of label: “RADIOACTIVE” “CONTENTS ...” “ACTIVITY ...” One red vertical bar shall follow the word: “RADIOACTIVE”
7B	Category II	Trefoil: black	Upper half yellow with white border, lower half white	7 (black)		Text (mandatory), black in lower half of label: “RADIOACTIVE” “CONTENTS ...” “ACTIVITY ...” In a black outlined box: “TRANSPORT INDEX”; Two red vertical bars shall follow the word: “RADIOACTIVE”
7C	Category III	Trefoil: black	Upper half yellow with white border, lower half white	7 (black)		Text (mandatory), black in lower half of label: “RADIOACTIVE” “CONTENTS ...” “ACTIVITY ...” In a black outlined box: “TRANSPORT INDEX”. Three red vertical bars shall follow the word: “RADIOACTIVE”
7E	Fissile material	-	White	7 (black)		Text (mandatory): black in upper half of label: “FISSILE”; In a black outlined box in the lower half of label: “CRITICALITY SAFETY INDEX”

Label model No.	Division or Category	Symbol and symbol colour	Background	Figure in bottom corner (and figure colour)	Specimen labels	Note
<b>Class 8: Corrosive substances</b>						
8	-	Liquids, spilling from two glass vessels and attacking a hand and a metal: black	Upper half white, lower half black with white border	8 (white)		-
<b>Class 9: Miscellaneous dangerous substances and articles, including environmentally hazardous substances</b>						
9	-	7 vertical stripes in upper half: black	White	9 underlined (black)		-
9A	-	7 vertical stripes in upper half: black; battery group, one broken and emitting flame in lower half: black	White	9 underlined (black)		-

”.

## Chapter 5.3

Amend the title of Chapter 5.3 to read as follows: “PLACARDING AND MARKING OF CARGO TRANSPORT UNITS AND BULK CONTAINERS”.

(Reference document: *ST/SG/AC.10/C.3/98/Add.1*)

5.3.1.1.2 In the first sentence, replace “risks” by “hazards” and after “transport unit” add “and bulk container”. In the second sentence, in (b), replace “risks” by “hazards” and after “transport unit” add “and bulk container”.

(Reference document: *ST/SG/AC.10/C.3/98/Add.1*)

5.3.1.1.3 In the first sentence, replace “risks” by “hazards” and “risk” by “hazard”. In the second sentence, replace “risk” by “hazard” twice.

(Reference document: *ST/SG/AC.10/C.3/98/Add.1*)

5.3.2.3.1 After “transport unit” add “or bulk container” (twice).

(Reference document: *ST/SG/AC.10/C.3/98/Add.1*)

5.3.2.3.2 After “cargo transport units” add “and bulk containers”.

(Reference document: *ST/SG/AC.10/C.3/98/Add.1*)

## Chapter 5.4

5.4.1.4.1 (c) The amendment does not apply to the English version.

(Reference document: *ST/SG/AC.10/C.3/98/Add.1, consequential amendment*)

5.4.1.4.1 (d) Replace “risk” by “hazard”.

(Reference document: *ST/SG/AC.10/C.3/98/Add.1*)

[5.4.1.5.5 In the heading, after “Self-reactive substances”, insert “, *polymerizing substances*”. In the text, after the words “self-reactive substances”, insert “and polymerizing substances”.]

(Reference document: *ST/SG/AC.10/C.3/96/Add.1*)

5.4.1.5.5.1 Replace “risk” by “hazard”.

(Reference document: *ST/SG/AC.10/C.3/98/Add.1*)

5.4.1.5.10 In the second paragraph, replace “the distinguishing sign for motor vehicles in international traffic” by “the distinguishing sign used on vehicles in international road traffic<sup>3</sup>”, with footnote 3 reading as follows:

“<sup>3</sup> Distinguishing sign of the State of registration used on motor vehicles and trailers in international road traffic, e.g. in accordance with the Geneva Convention on Road Traffic of 1949 or the Vienna Convention on Road Traffic of 1968”.

For Chapter 5.4, renumber subsequent footnotes accordingly.

(Reference document: *ST/SG/AC.10/C.3/98/Add.1*)

## Chapter 6.1

In the heading of the chapter, delete “(OTHER THAN FOR DIVISION 6.2 SUBSTANCES)”.

(Reference document: ST/SG/AC.10/C.3/94)

6.1.1.1 (a) (i) Replace “(subsidiary risks)” by “(subsidiary hazards)”.

(Reference document: ST/SG/AC.10/C.3/98/Add.1)

6.1.1.1 Add a new sub-paragraph (e) to read as follows:

“(e) Packagings for Division 6.2 infectious substances of Category A.”.

(Reference document: ST/SG/AC.10/C.3/94)

6.1.3, Nota 3 The amendment does not apply to the English version.

(Reference document: ST/SG/AC.10/C.3/98/Add.1, consequential amendment)

6.1.3.1 (f) Replace “indicated by the distinguishing sign for motor vehicles in international traffic” by “indicated by the distinguishing sign used on vehicles in international road traffic<sup>2</sup>”.

6.1.3.8 (h) Replace “indicated by the distinguishing sign for motor vehicles in international traffic” by “indicated by the distinguishing sign used on vehicles in international road traffic<sup>2</sup>”.

Footnote 2 reads as follows: “<sup>2</sup> Distinguishing sign of the State of registration used on motor vehicles and trailers in international road traffic, e.g. in accordance with the Geneva Convention on Road Traffic of 1949 or the Vienna Convention on Road Traffic of 1968.”.

(Reference document: ST/SG/AC.10/C.3/98/Add.1)

6.1.5.7 Under item 8, add the following sentence at the end: “For plastics packagings subject to the internal pressure test in 6.1.5.5, the temperature of the water used.”.

(Reference document: ST/SG/AC.10/C.3/98/Add.1)

## Chapter 6.2

6.2.1.6.1 (d) Replace the existing Note 2 with the following:

**NOTE 2:** For seamless steel cylinders and tubes the check of 6.2.1.6.1 (b) and hydraulic pressure test of 6.2.1.6.1 (d) may be replaced by a procedure conforming to ISO 16148:2016 ‘Gas cylinders – Refillable seamless steel gas cylinders and tubes – Acoustic emission examination (AT) and follow-up ultrasonic examination (UT) for periodic inspection and testing’.

(Reference document: ST/SG/AC.10/C.3/98/Add.1)

6.2.1.6.1 (d) In Note 3, replace “The hydraulic pressure test may be replaced” by “The check of 6.2.1.6.1 (b) and the hydraulic pressure test of 6.2.1.6.1 (d) may be replaced”.

(Reference document: ST/SG/AC.10/C.3/98/Add.1)

6.2.2.1.1 In the table, for “ISO 11118:1999”, in the column “Applicable for manufacture”, replace “Until further notice” by “Until 31 December 2020”.

6.2.2.1.1 In the table, after “ISO 11118:1999”, insert a new line to read as follows:

ISO 11118:2015	Gas cylinders – Non-refillable metallic gas cylinders – Specification and test methods	Until further notice
----------------	--	----------------------

(Reference document: ST/SG/AC.10/C.3/96/Add.1)

6.2.2.1.2 In the table, for “ISO 11120:1999”, in the column “Applicable for manufacture”, replace “Until further notice” by “Until 31 December 2022”.



6.2.2.1.2 In the table, after “ISO 11120:1999”, insert a new line to read as follows:

ISO 11120:2015	Gas cylinders – Refillable seamless steel tubes of water capacity between 150 l and 3 000 l – Design, construction and testing	Until further notice
----------------	--	----------------------

(Reference document: ST/SG/AC.10/C.3/96/Add.1)

6.2.2.1 Insert a new paragraph 6.2.2.1.8 to read as follows.

“6.2.2.1.8 The following standards apply for the design, construction and initial inspection and test of UN pressure drums, except that inspection requirements related to the conformity assessment system and approval shall be in accordance with 6.2.2.5:

Reference	Title	Applicable for Manufacture
ISO 21172-1:2015	Gas cylinders – Welded steel pressure drums up to 3 000 litres capacity for the transport of gases – Design and construction – Part 1: Capacities up to 1 000 litres <i>NOTE: Irrespective section 6.3.3.4 of this standard, welded steel gas pressure drums with dished ends convex to pressure may be used for the transport of corrosive substances provided all applicable requirements of these Regulations are met.</i>	Until further notice
ISO 4706: 2008	Gas cylinders – Refillable welded steel cylinders – Test pressure 60 bar and below;	Until further notice
ISO 18172-1:2007	Gas cylinders – Refillable welded stainless steel cylinders – Part 1: Test pressure 6 MPa and below	Until further notice

(Reference document: ST/SG/AC.10/C.3/96/Add.1 and ST/SG/AC.10/C.3/98/Add.1)

6.2.2.3 In the first table, for “ISO 13340:2001”, in the column “Applicable for manufacture”, replace “Until further notice” by “Until 31 December 2020”.

(Reference document: ST/SG/AC.10/C.3/96/Add.1)

6.2.2.3 In the first table, insert a new final row reading as follows:

ISO 17871:2015	Gas cylinders – Quick-release cylinders valves- Specification and type testing	Until further notice
----------------	--	----------------------

(Reference document: ST/SG/AC.10/C.3/98/Add.1)

6.2.2.3 In the first table, insert the following row at the end:

ISO 14246:2014	Gas cylinders – Cylinder valves – Manufacturing tests and examination	Until further notice
----------------	---	----------------------

(Reference document: ST/SG/AC.10/C.3/94)

6.2.2.4 Amend the end of the introductory sentence to read: “...testing of UN cylinders and their closures.”.

Move the last row of the table into a new table, after the existing one, with the same headings and a new introductory sentence to read: “The following standard applies to the periodic inspection and testing of UN metal hydride storage systems.”.

(Reference document: ST/SG/AC.10/C.3/94)

6.2.2.4 In the table, for “ISO 11623:2002”, in column “Applicable”, replace “Until further notice” by “Until 31 December 2020”. After the row for “ISO 11623:2002” insert the following new row:

ISO 11623:2015	Gas cylinders – Composite construction – Periodic inspection and testing	Until further notice
----------------	--	----------------------

(Reference document: ST/SG/AC.10/C.3/98/Add.1)

6.2.2.4 At the end of the first table, insert the following row:

ISO 22434:2006	Transportable gas cylinders – Inspection and maintenance of cylinder valves <b>NOTE:</b> <i>These requirements may be met at times other than at the periodic inspection and test of UN cylinders</i>	Until further notice
----------------	--	----------------------

(Reference document: ST/SG/AC.10/C.3/94)

6.2.2.7.2 (c) Replace “indicated by the distinguishing signs for motor vehicles in international traffic” by: “the distinguishing sign used on vehicles in international road traffic<sup>2</sup>”.

6.2.2.7.4 Under subparagraph (m), insert a new Note to read as follows:

**“NOTE:** *Information on marks that may be used for identifying threads for cylinders is given in ISO/TR 11364, Gas cylinders – Compilation of national and international valve stem/gas cylinder neck threads and their identification and marking system.”.*

(Reference document: ST/SG/AC.10/C.3/94)

6.2.2.7.4 (n) Replace “indicated by the distinguishing signs for motor vehicles in international traffic<sup>3</sup>” by: “the distinguishing sign used on vehicles in international road traffic<sup>2</sup>”.

(Reference document: ST/SG/AC.10/C.3/98/Add.1)

6.2.2.7.7 (a) Replace “indicated by the distinguishing signs of motor vehicles in international traffic<sup>3</sup>” by: “the distinguishing sign used on vehicles in international road traffic<sup>2</sup>”.

(Reference document: ST/SG/AC.10/C.3/98/Add.1)

6.2.2.9.2 (c) and (h) Replace “indicated by the distinguishing signs of motor vehicles in international traffic<sup>3</sup>” by: “the distinguishing sign used on vehicles in international road traffic<sup>2</sup>”.

(Reference document: ST/SG/AC.10/C.3/98/Add.1)

6.2.2.9.4 (a) Replace “indicated by the distinguishing signs of motor vehicles in international traffic<sup>3</sup>” by: “the distinguishing sign used on vehicles in international road traffic<sup>2</sup>”.

Footnote 2 reads as follow:

<sup>2</sup> Distinguishing sign of the State of registration used on motor vehicles and trailers in international road traffic, e.g. in accordance with the Geneva Convention on Road Traffic of 1949 or the Vienna Convention on Road Traffic of 1968”.

(Reference document: ST/SG/AC.10/C.3/98/Add.1)

6.2.4.3 Renumber footnote 2 as footnote 3

(Reference document: ST/SG/AC.10/C.3/98/Add.1)

## Chapter 6.3

6.3.4.2 (e) Replace “indicated by the distinguishing sign for motor vehicles in international traffic<sup>2</sup>” by: “the distinguishing sign used on vehicles in international road traffic<sup>1</sup>”.

Footnote 1 reads as follows: “<sup>1</sup> Distinguishing sign of the State of registration used on motor vehicles and trailers in international road traffic, e.g. in accordance with the Geneva Convention on Road Traffic of 1949 or the Vienna Convention on Road Traffic of 1968”.

(Reference document: ST/SG/AC.10/C.3/98/Add.1)

## Chapter 6.4

6.4.23.11 (a) In paragraph (a), replace “the international vehicle registration identification code<sup>1</sup>” by “the distinguishing sign used on vehicles in international road traffic<sup>1</sup>”.

Amend footnote 1 to read as follows: “<sup>1</sup> Distinguishing sign of the State of registration used on motor vehicles and trailers in international road traffic, e.g. in accordance with the Geneva Convention on Road Traffic of 1949 or the Vienna Convention on Road Traffic of 1968.”.

(Reference document: ST/SG/AC.10/C.3/98/Add.1)

## Chapter 6.5

6.5.2.1.1 (e) Replace “indicated by the distinguishing sign for motor vehicles in international traffic<sup>2</sup>” by: “the distinguishing sign used on vehicles in international road traffic<sup>1</sup>”.

Footnote 1 reads as follows: “<sup>1</sup> Distinguishing sign of the State of registration used on motor vehicles and trailers in international road traffic, e.g. in accordance with the Geneva Convention on Road Traffic of 1949 or the Vienna Convention on Road Traffic of 1968”

(Reference document: ST/SG/AC.10/C.3/98/Add.1)

6.5.6.9.3 Amend the last paragraph to read as follows:

“The same IBC or a different IBC of the same design may be used for each drop.”

(Reference document: ST/SG/AC.10/C.3/98/Add.1)

6.5.6.14.1 Under item 8, add the following sentence: “For rigid plastics and composite IBCs subject to the hydraulic pressure test in 6.5.6.8, the temperature of the water used.”.

(Reference document: ST/SG/AC.10/C.3/98/Add.1)

## Chapter 6.6

6.6.3.1 (e) Replace indicated by the distinguishing sign for motor vehicles in international traffic<sup>2</sup>” by “indicated by the distinguishing sign used on vehicles in international road traffic<sup>1</sup>”.

Footnote 1 should read as follows: “<sup>1</sup> *Distinguishing sign of the State of registration used on motor vehicles and trailers in international road traffic, e.g. in accordance with the Geneva Convention on Road Traffic of 1949 or the Vienna Convention on Road Traffic of 1968.*”

(Reference document: ST/SG/AC.10/C.3/98/Add.1)

## Chapter 6.7

6.7.2.2.16 The amendment does not apply to the English version.

(Reference document: ST/SG/AC.10/C.3/98/Add.1, consequential amendment)

6.7.2.18.1 In the fourth sentence, replace “i.e. the distinguishing sign for use in international traffic as prescribed by the Convention on Road Traffic, Vienna 1968” by “indicated by the distinguishing sign used on vehicles in international road traffic<sup>2</sup>”.

6.7.3.14.1 In the fourth sentence, replace “i.e. the distinguishing sign for use in international traffic, as prescribed by the Convention on Road Traffic, Vienna 1968” by “indicated by the distinguishing sign used on vehicles in international road traffic<sup>2</sup>”.

6.7.4.13.1 In the fourth sentence, replace “i.e. the distinguishing sign for use in international traffic as presented by the Convention on Road Traffic, Vienna 1968” by “indicated by the distinguishing sign for use in international road traffic<sup>2</sup>”.

6.7.5.11.1 In the fourth sentence, replace “i.e. the distinguishing sign for use in international traffic, as prescribed by the Convention on Road Traffic, Vienna 1968” by “indicated by the distinguishing sign used on vehicles in international road traffic<sup>2</sup>”.

Footnote 2 should read as follows: “<sup>2</sup> *Distinguishing sign of the State of registration used on motor vehicles and trailers in international road traffic, e.g. in accordance with the Geneva Convention on Road Traffic of 1949 or the Vienna Convention on Road Traffic of 1968.*”.

Under chapter 7.2, renumber the following footnotes accordingly.

(Reference document: ST/SG/AC.10/C.3/98/Add.1)

## Chapter 6.8

6.8.5.1 (e) Replace “indicated by the distinguishing signs for motor vehicles in international traffic” by: “the distinguishing signs used on vehicles in international road traffic<sup>2</sup>”.

Footnote 2 reads as follows: “<sup>2</sup> *Distinguishing sign of the State of registration used on motor vehicles and trailers in international road traffic, e.g. in accordance with the Geneva Convention on Road Traffic of 1949 or the Vienna Convention on Road Traffic of 1968.*”.

(Reference document: ST/SG/AC.10/C.3/98/Add.1)

## Chapter 7.1

7.1.2.3 (c) Replace “risk” by “hazard” (three times).

(Reference document: ST/SG/AC.10/C.3/98/Add.1)

7.1.5.1 The amendment does not apply to the English version.

(Reference document: ST/SG/AC.10/C.3/98/Add.1, consequential amendment)

---