



Economic and Social Council

Distr.: General
4 April 2014

Original: English

Committee of Experts on the Transport of Dangerous Goods and on the Globally Harmonized System of Classification and Labelling of Chemicals

Sub-Committee of Experts on the Transport of Dangerous Goods

Forty-fifth session

Geneva, 23 June – 2 July 2014

Item 2 (b) of the provisional agenda

Explosives and related matters: review of test series 6

Manual of Tests and Criteria

Proposed field-portable gas fuel UN 6(c) test assembly

Transmitted by the expert from the United States of America¹

Background

1. At the previous session of the Sub-Committee of Experts on the Transport of Dangerous Goods, the United States of America described research in the development of a practical and field-portable gas fuel UN test 6(c) assembly (see informal document INF.47, 44th session).
2. According to the current Manual of Tests and Criteria section 16.6.1.3 procedure for conducting the Test 6(c) external fire (bonfire test): “Suitable methods of heating include a wood fire using a lattice of wooden laths, a liquid or gas fuel fire, that produces a flame temperature of at least 800 °C”. Furthermore, section 16.6.1.3.4 states that: “If gas is to be used as a fuel, the burning area must extend beyond the packaging or unpackaged articles to a distance of 1.0 m in every direction. The gas must be supplied in such a manner to ensure the fire is evenly distributed around the packages. The gas reservoir should be large enough to keep the fire burning for at least 30 minutes. Ignition of the gas may be accomplished either by remotely ignited pyrotechnics or by remote release of the gas adjacent to a pre-existing source of ignition.”

¹ In accordance with the programme of work of the Sub-Committee for 2013-2014 approved by the Committee at its sixth session (refer to ST/SG/AC.10/C.3/84, para. 86 and ST/SG/AC.10/40, para. 14).

Discussion

3. Much type 6(c) testing is still conducted with wood-fuel, even though there are advantages of using a gas fuel over a wood fuel fire such as sustainable constant temperature and less post-test clean-up. Similarly, there are advantages using gas fuel over liquid fuel including lack of heavy black smoke and less temperature variability.
4. The proposed gas fuel burner assembly is approximately 2.5 square meters (m²) when complete and fabricated of carbon steel with inlets for gas at either end. A 32 minute field trial was conducted to demonstrate the feasibility and other possible benefits such as lower thermal flux noise from fuel. In order to maintain constant flame temperature of approximately 800°C for the 32 minutes, twelve (12) cylinders surrounded with a sufficiently sized ambient temperature water bath were used. The trial consumed approximately 8.3-8.4 kg/min (16.9-17.1 l/min) over all 12 cylinders or approximately 0.7 kg/min (1.4 l/min) per cylinder. This trial was instrumented with thermal flux gauges and successfully met the general criteria for a gas fuelled 6(c) fire as detailed in paragraph 2.
5. An additional trial was conducted with propellant to see if thermal flux measurements obtained using a gas-fed 6(c) bonfire test would prove advantageous when compared to other fuels (liquid and wood) Two packages of propellant were placed on the test stand and thermal flux gauges were positioned at 5, 10, and 15 m away from two adjacent sides of the fire. The results of this trial indicate that there may be some advantage to utilizing a gas fed fire for determining thermal irradiance of a material.
6. The annex to this paper includes diagrams for the prototype field-portable Test 6(c) gas fuel burner assembly. The Sub-Committee is invited to review the information provided and to provide any comments on the adequacy of the test apparatus and procedure in applying the Manual of Tests and Criteria Test Series 6(c) directly to Mr. Brian Vos at brian.vos@dot.gov.

Annex

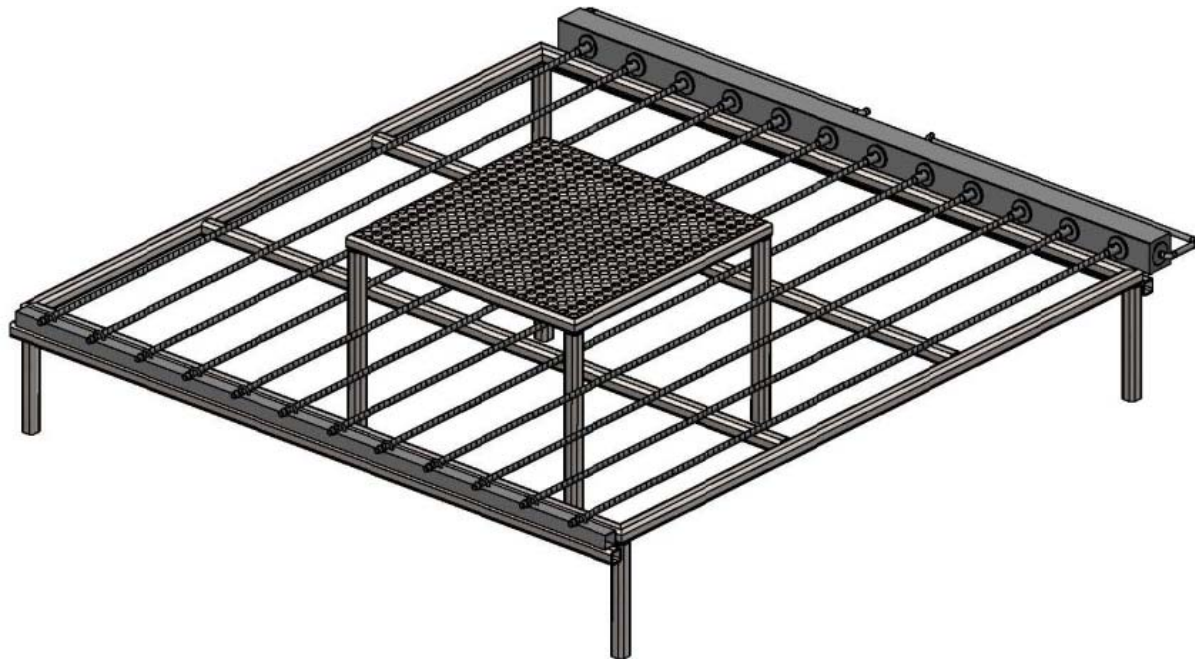

Figure 1: Proposed USA gas-fueled Test 6c burner assembly

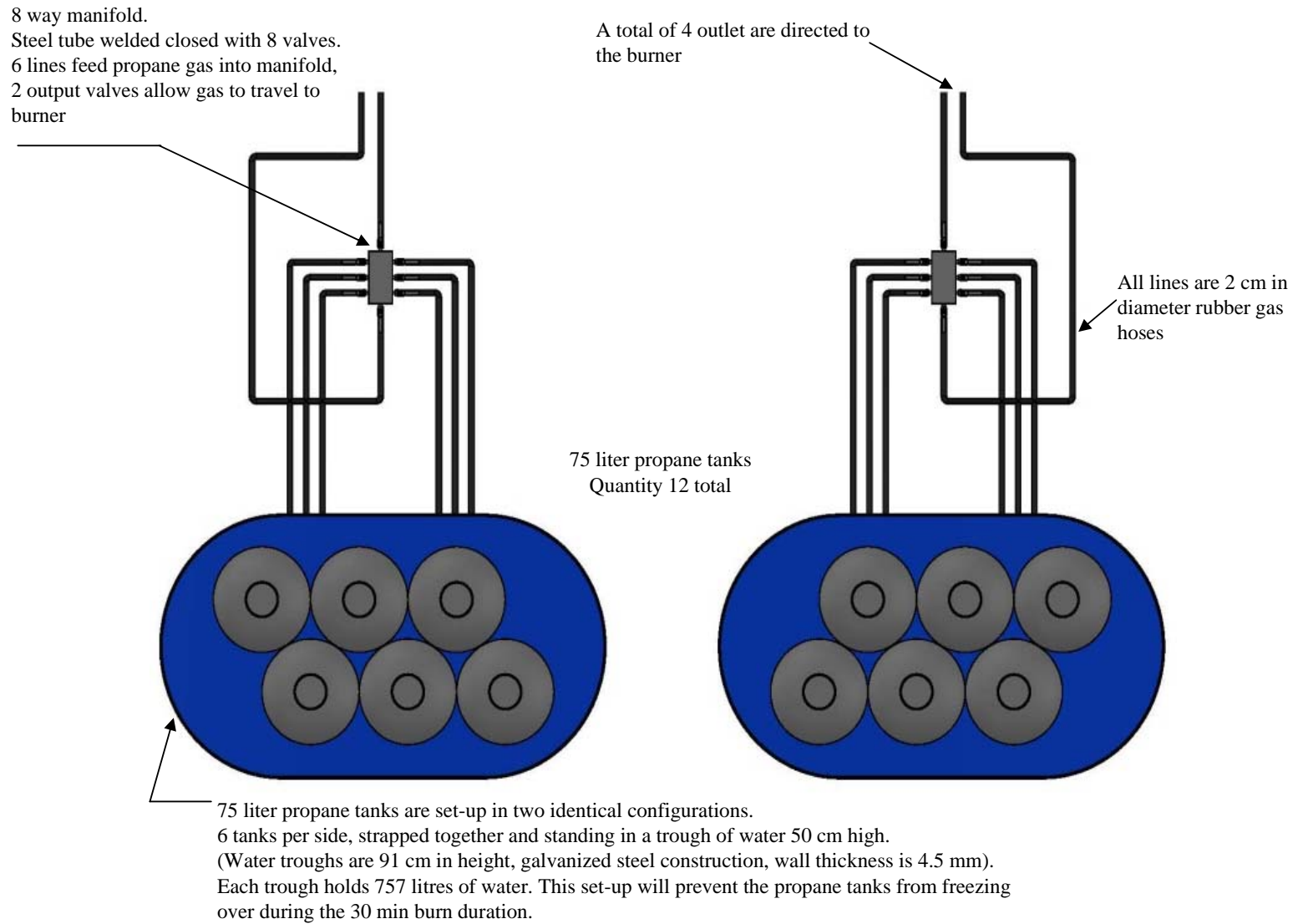
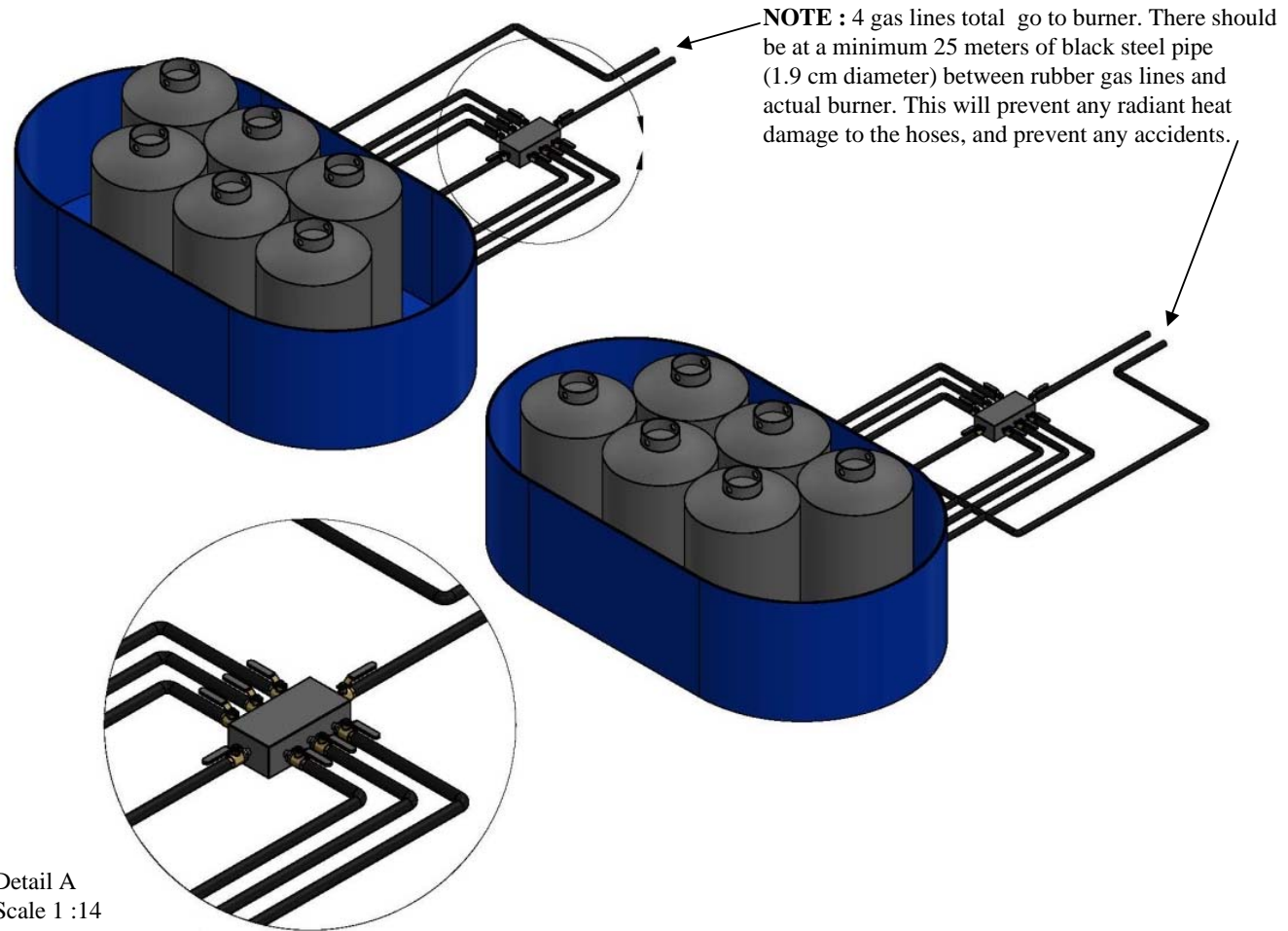

Figure 2: Proposed USA gas-fueled Test 6c

Propane source and distribution



**Figure 3: Proposed USA gas-fueled Test 6c burner assembly
Propane source and distribution**

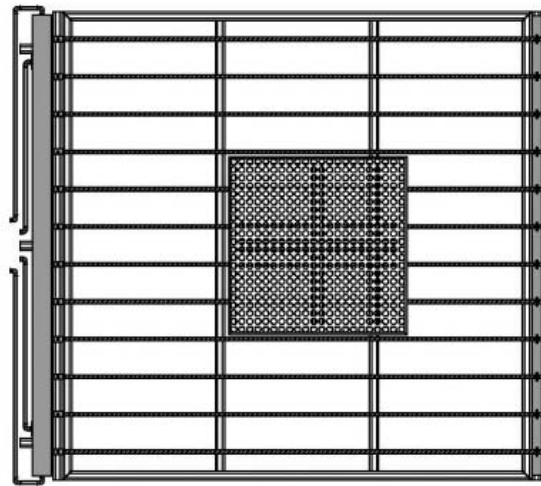
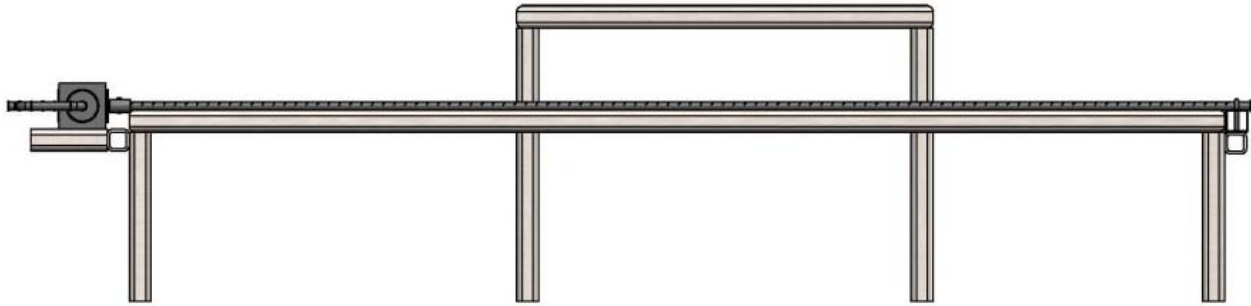
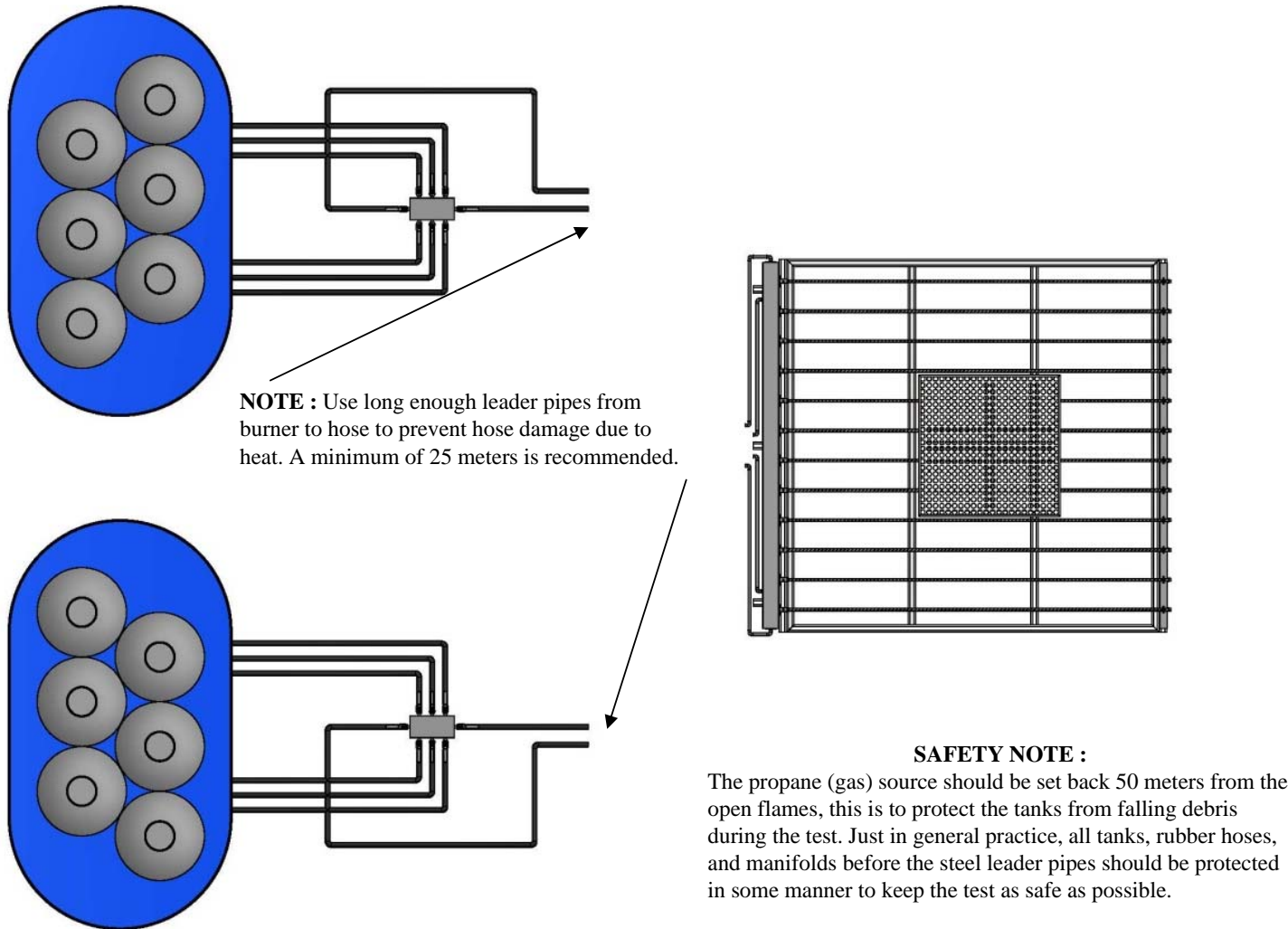
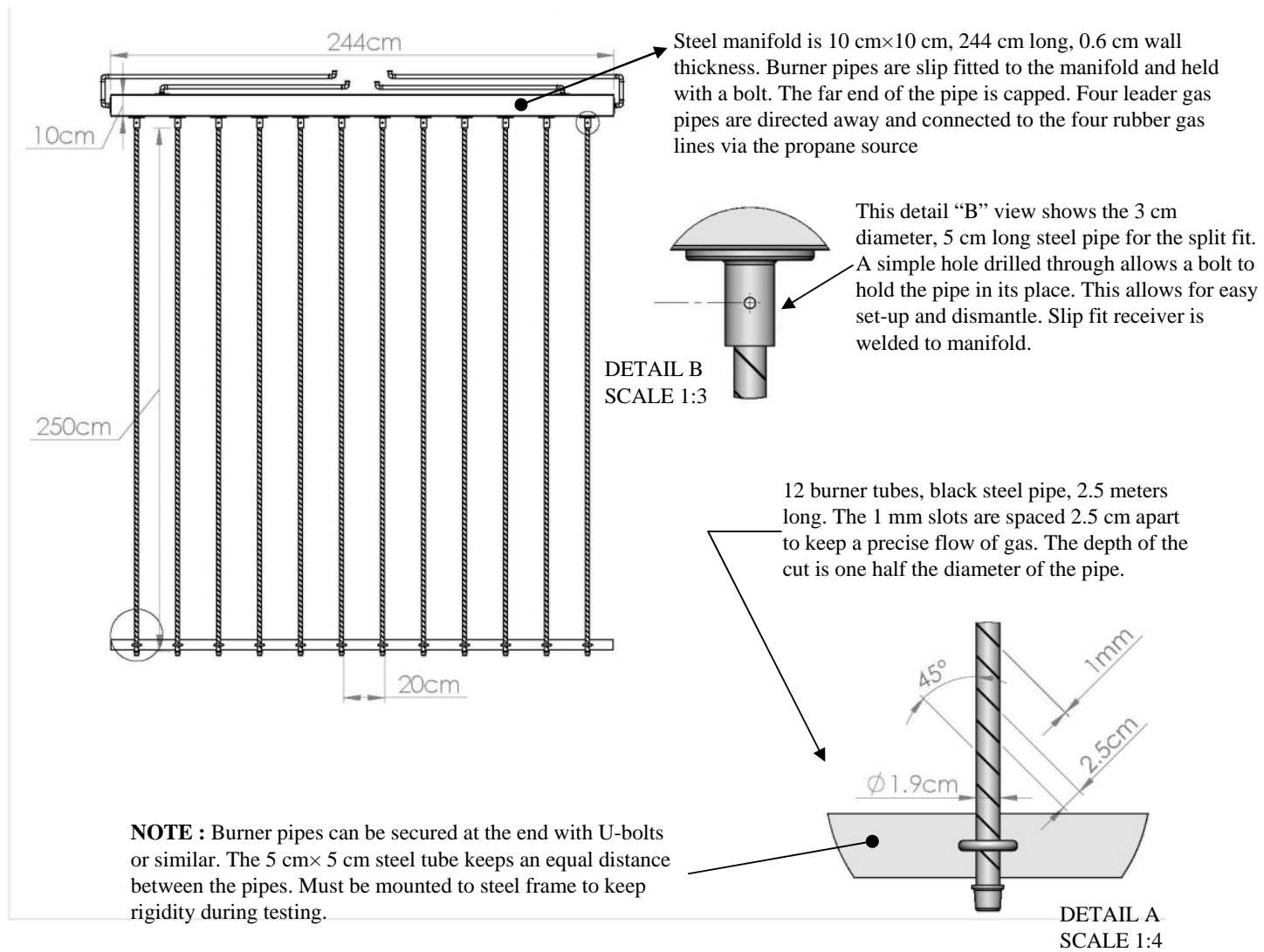

Figure 5: Proposed USA gas-fueled Test 6c burner assembly

Burner assembly



**Figure 6: Proposed USA gas-fueled Test 6c burner assembly
Propane and burner assembly**



**Figure 7: Proposed USA gas-fueled Test 6c burner assembly
Burner construction**

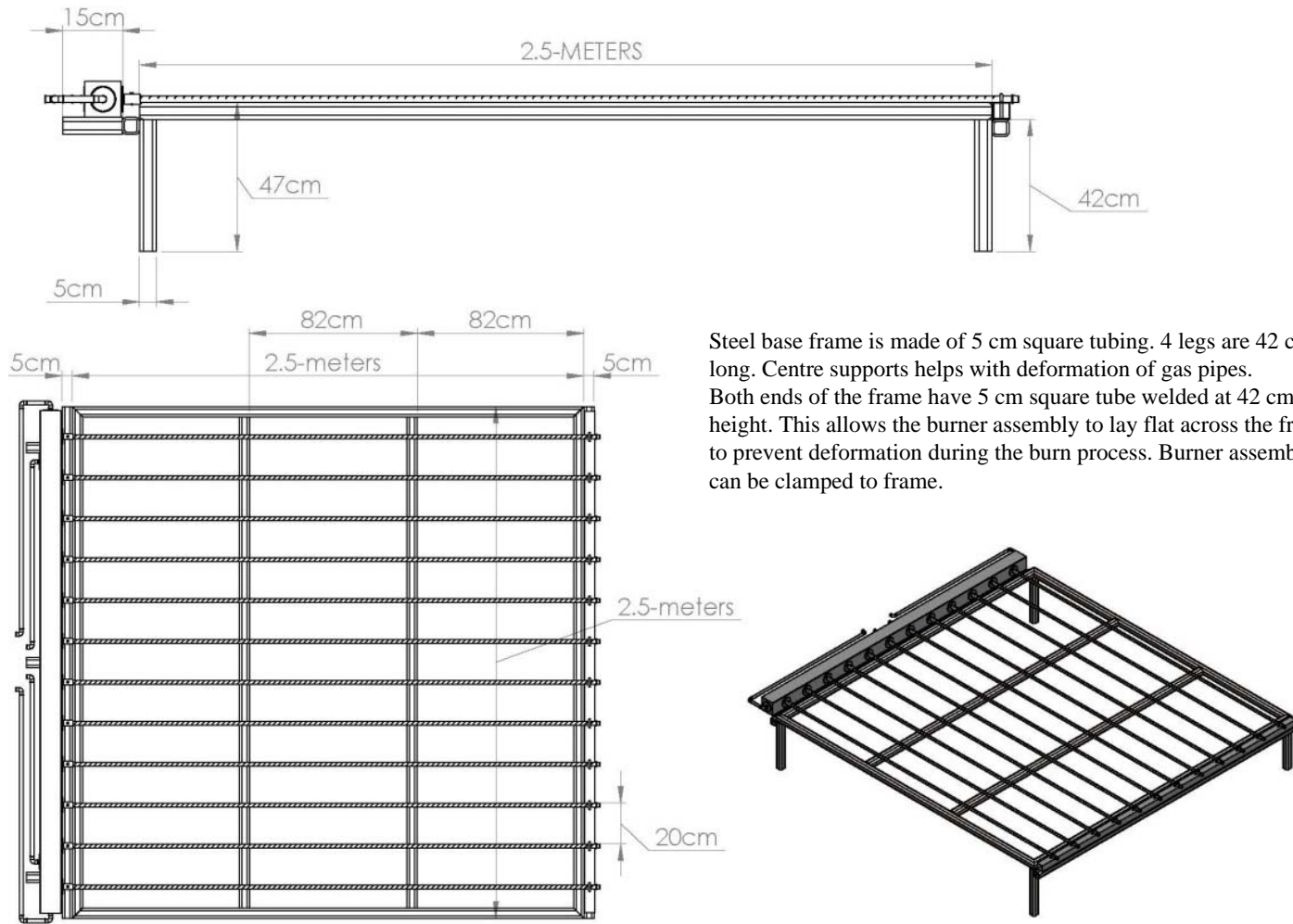

Figure 8: Proposed USA gas-fueled Test 6c burner assembly Base frame