



Economic and Social Council

Distr.: General
23 July 2013

Original: English

Economic Commission for Europe

Inland Transport Committee

World Forum for Harmonization of Vehicle Regulations

161st session

Geneva, 12-15 November 2013

Item 4.8.10. of the provisional agenda

**1958 Agreement – Consideration of draft amendments
to existing Regulations submitted by GRSP**

Proposal for Supplement 2 to Regulation No. 129 on Enhanced Child Restraint Systems (ECRS)

Submitted by the Working Party on Passive Safety*

The text reproduced below was adopted by the Working Party on Passive Safety (GRSP) at its fifty-third session (ECE/TRANS/WP.29/GRSP/53, para. 44). It is based on ECE/TRANS/WP.29/GRSP/2013/12 as amended by Annex VII to the report. It is submitted to the World Forum for Harmonization of Vehicle Regulations (WP.29) and to the Administrative Committee AC.1 for consideration.

* In accordance with the programme of work of the Inland Transport Committee for 2010–2014 (ECE/TRANS/208, para. 106 and ECE/TRANS/2010/8, programme activity 02.4), the World Forum will develop, harmonize and update regulations in order to enhance the performance of vehicles. The present document is submitted in conformity with that mandate.

List of Annexes,

Insert a reference to a new Annex 21, to read:

" 21 Load application devices"

Paragraph 2.30., amend to read:

"2.30. "Lap strap" means a strap which, either in the form of a complete belt or in the form of a component of such a belt passes across the front of, and restrains, directly or not, the child's pelvis."

Paragraph 3.2.1., amend to read:

"3.2.1. A technical description of the child restraint system ... , declaration on toxicity (para. 6.3.1.1.) and flammability (para. 6.3.1.2.), the drawings shall show the position intended for a single approval number and additional symbol(s) in relation to the circle of the approval mark;"

Paragraph 4.5., the figure, amend to read:

"4.5. In the case of ...
Minimum label size 40 x 40 mm

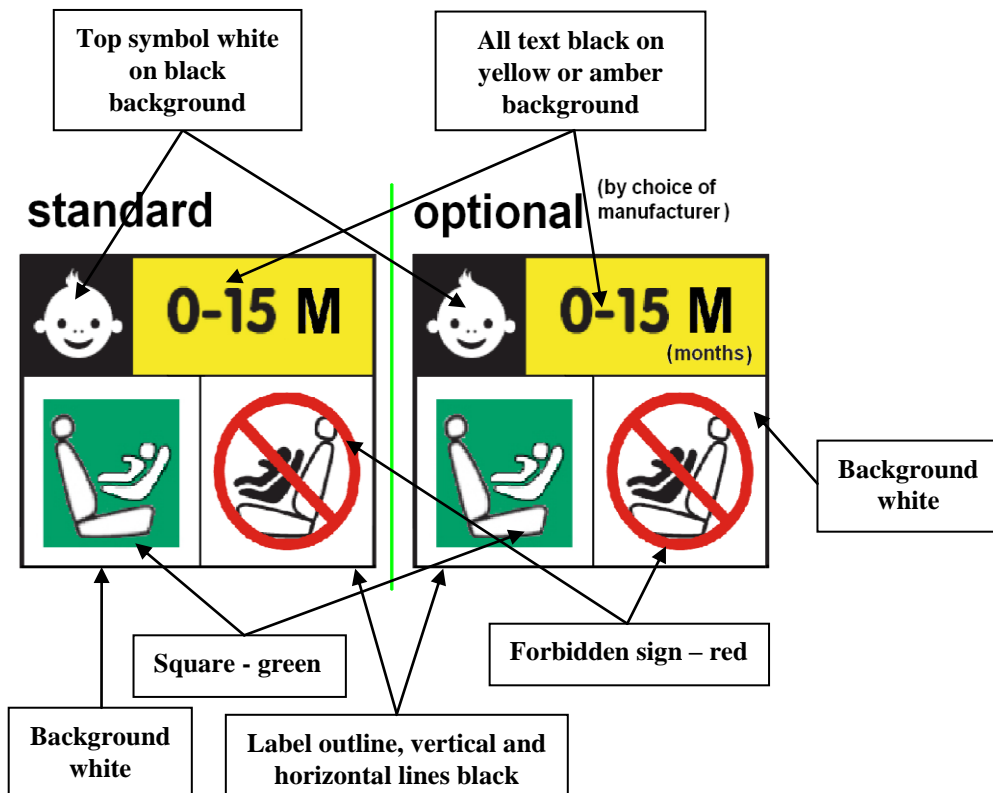

Paragraph 4.8., amend to read

"4.8. Additional Marking

...

(c) The position ...

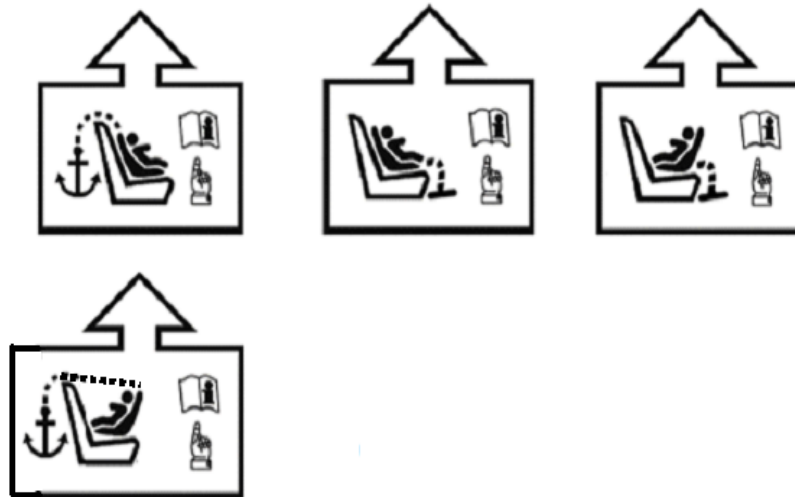

(d) ..."

Paragraph 5.4.1.2., amend to read:

"5.4.1.2. An approval number, the words "Regulation No." followed by the number of this Regulation, a slash and the series of amendment ("Regulation No. XXX/XX");"

Paragraph 5.4.2.1., amend to read:

"5.4.2.1. The words "i-Size universal ISOFIX" or "specific vehicle ISOFIX" depending on the category of Child Restraint System;"

Paragraph 6.2.1.4., amend to read:

"6.2.1.4. To prevent submarining, either by impact or through restlessness, a crotch strap shall be required on all forward-facing restraints incorporating an integral harness belt system."

Paragraph 6.2.1.5., amend to read:

"6.2.1.5. All restraint devices utilizing a "lap strap" must positively guide the "lap strap" to ensure that the loads transmitted by the "lap strap" are transmitted through the pelvis. The assembly shall not ... collision;"

Insert new paragraphs 6.2.1.7. and 6.2.1.8., to read:

"6.2.1.7. With the crotch strap attached and in its longest position if adjustable, it shall not be possible to adjust the lap strap to lie above the pelvis of both the smallest and largest dummy within the mass groups covered by the approval. For all forward-facing restraints, it shall not be possible to adjust the lap strap to lie above the pelvis of both the smallest and largest dummy within the mass groups covered by the approval.

6.2.1.8. During the dynamic test, as prescribed in paragraph 8.1.3., the lap belt shall not pass fully beyond the pelvic structure of the dummy during the period prior to maximum horizontal head excursion. An assessment shall be carried out using high speed video imaging."

Paragraphs 6.3.1.1. and 6.3.1.2., amend to read:

"6.3.1.1. The child restraint system ... of EN 71-3:1994/A1:2000/AC. Tests confirming the validity of the declaration may be carried out at the discretion of the test authority.

6.3.1.2. The child restraint system ... of EN 71-2:2011. Tests confirming the validity of the declaration may be carried out at the discretion of the test authority."

Paragraphs 6.3.5. to 6.3.5.3., amend to read:

"6.3.5. i-Size child restraint system support-leg and support-leg foot requirements

...

The orientation ... fixture(s):

- (a) The X' axis shall be parallel to the child restraint fixture (CRF)¹ bottom surface and in the median longitudinal plane of the CRF;
- (b) The Y' axis shall be perpendicular to the median longitudinal plane;
- (c) The Z' axis shall be perpendicular to the CRF bottom surface.

In fulfilling the ...

6.3.5.1. Support-leg and support-leg foot geometrical requirements

The support leg, ... is defined as follows:

- (a) In width by two planes parallel to the X'-Z' plane separated by 200 mm, and centered around the origin; and
- (b) In length by two planes parallel to the Z'-Y' plane and positioned at distances of 585 mm and 695 mm forward of the origin along the X' axis; and
- (c) In height by a plane parallel to the X'-Y' plane, positioned at a distance of 70 mm above the origin and measured perpendicular to the X'-Y' plane. Rigid, non-adjustable parts of the support leg shall not extend beyond a plane parallel to the X'-Y' plane, positioned at a distance of 285 mm below the origin and perpendicular to the X'-Y' plane.

6.3.5.2. Support-leg foot adjustability requirements

The support-leg ... 20 mm.

The support leg foot assessment volume is defined as follows:

- (a) In width by two planes parallel to the X'-Z' plane, separated by 200 mm, and centered around the origin; and
- (b) In length by two planes parallel to the Z'-Y' plane and positioned at distances of 585 mm and 695 mm forward of the origin along the X' axis; and
- (c) In height by two planes parallel to the X'-Y' plane positioned at distances of 285 mm and 540 mm below the origin along the X' axis.

It shall be permissible for the support-leg to be adjustable beyond the height limits in the Z' direction (as indicated by key 6 in figure 3 of Annex 19), providing that no parts extend beyond the limiting planes in the X' and Y' directions.

6.3.5.3. Support-leg foot dimensions

The dimensions ...

- (b) Minimum outside dimensions shall be 30 mm in the X' and Y' ..."

¹ Child restraint fixture (CRF) as defined in Regulation No. 16 (Safety-belts)

Paragraph 6.6.2.1., amend to read:

"6.6.2.1. For all devices with backrests, the areas defined in Annex 14 to this Regulation, when tested according to Annex 13, shall give a peak acceleration of less than 60g. This requirement applies also to areas of impact shields which are in the head strike area."

Paragraph 6.6.2.2., amend to read:

"6.6.2.2. In the case of child restraint systems with permanent mechanically attached adjustable head support devices, in which the height of either the adult safety belt or of the child harness is directly controlled by the adjustable head support, it is not necessary to demand energy absorption in areas as defined in Annex 18, which are not contactable by the manikin's head, i.e. behind the head support."

Paragraph 6.6.3.1., amend to read:

"6.6.3.1. The child restraint system shall be tested as prescribed in paragraph 7.1.2.; at no point during the whole test shall the manikin be fully ejected from the device. In addition when the test seat is in the upside down position, the dummy's head shall not move more than 300 mm from its original position in a vertical direction relative to the test seat."

Paragraph 6.7.3.2.6., amend to read:

"6.7.3.2.6. The strap shall be repeatedly withdrawn from the retractor and allowed to retract, in the conditions prescribed in paragraph 7.2.4.2., until 40,000 cycles have been completed. The retractor shall then be subjected to the temperature test operation requirements given in paragraph 7.2.7. and corrosion test described in paragraph 7.1.1. and to the dust-resistance test described in paragraph 7.2.4.5."

Insert new paragraphs 6.7.5.1. and 6.7.5.2., to read:

"6.7.5.1. ISOFIX attachments and latching indicators shall be capable of withstanding repeated operations and shall, before the dynamic test prescribed in paragraph 7.1.3., undergo a test comprising 2000 ± 5 opening and closing cycles under normal conditions of use."

6.7.5.2. ISOFIX attachments shall have a locking mechanism which complies with the requirements specified in (a) or (b) as follows:

- (a) Release of the locking mechanism of the complete seat, shall require two consecutive actions, the first of which should be maintained while the second is carried out; or
- (b) The ISOFIX attachment opening force shall be at least 50 N when tested as prescribed in paragraph 7.2.8. below."

Paragraph 7.1.2.1., amend to read:

"7.1.2.1. The manikin shall be equipped with either of the load application devices as appropriate, and described in Annex 21. Place the manikin in the restraints installed in accordance with this Regulation and taking into account the manufacturer's instructions and with the standard slack as specified in paragraph 7.1.3.5., applied for all systems identically."

Paragraph 7.1.2.2., amend to read:

"7.1.2.2. The restraint shall be fastened to the test bench or vehicle seat. The whole child restraint system shall be rotated around a horizontal axis contained in the median longitudinal plane of the child restraint system through an angle

of $540^\circ \pm 5^\circ$ at a speed of 2-5 degrees/second and stopped in this position. For the purposes of this test, devices intended for use in specific cars may be attached to the test bench described in Annex 6."

Insert new paragraphs 7.1.2.3. to 7.1.2.5., to read:

"7.1.2.3. At this static inverted position, a mass equivalent to four times that of the dummy shall be applied vertically downwards in a plane perpendicular to the axis of rotation in addition to the dummy utilizing the load application device described in Annex 21. The load shall be applied in a gradual controlled manner at a rate not exceeding gravitational acceleration or 400mm/min. Maintain the prescribed maximum load for a duration of 30 -0/+5 seconds.

7.1.2.4. Remove the load at a rate not exceeding 400 mm/min and measure displacement.

7.1.2.5. Rotate the whole seat for 180° to return to the starting position."

Paragraph 7.1.2.3.(former), renumber as paragraph 7.1.2.6. and amend to read:

"7.1.2.6. This test cycle shall be carried out again rotating in the reverse direction. With the rotational axis in the horizontal plane and at 90° to that of the two earlier tests, the procedure shall be repeated in the two directions of rotation."

Paragraph 7.1.2.4.(former), renumber as paragraph 7.1.2.7. and amend to read:

"7.1.2.7. These tests shall be carried out using both the smallest and the largest appropriate dummy of the size range for which the restraining device is intended. Any adjustment of the dummy or child restraint systems during the complete test cycle is not allowed."

Paragraph 7.1.2.5. (former), renumber as paragraph 7.1.2.8.

Paragraph 7.1.3.5.2.1., amend to read:

"7.1.3.5.2.1. Installation of a child restraint system on the test bench.

...

The dummy ... The resulting height of the spacer is listed in the table below for the different dummy sizes. The board should follow as closely as possible the curvature of the chair and its lower end should be at the height of the dummy's hip joint.

..."

Paragraph 7.2.1.3.2., amend to read:

"7.2.1.3.2. Annex 16 shows a typical device ..."

Insert new paragraphs 7.2.8. to 7.2.8.5., to read:

"7.2.8. The complete seat, or the component fitted with ISOFIX attachments (e.g. ISOFIX base) if it has a release button, is attached rigidly to a test rig in such a way that ISOFIX connectors are vertically aligned as shown in Figure 3. A 6 mm diameter bar, 350 mm long, shall be attached to the ISOFIX connectors. A mass of 5 kg shall be attached to the extremities of the bar.

7.2.8.1. An opening force shall be applied to the release button or handle along a fixed axis running parallel to the initial direction of motion of the button/handle; the geometric centre applies to that part of the surface of the ISOFIX attachment to which the release pressure is to be applied.

7.2.8.2. The ISOFIX attachment opening force shall be applied using a dynamometer or similar device in the normal manner and direction as indicated in the

manufacturers user manual. The contact end shall be a polished metal hemisphere with radius 2.5 ± 0.1 mm for a release button or a polished metal hook with a radius of 25 mm.

- 7.2.8.3. If the design of the child restraint prevents the application of the procedure described in paragraphs 7.2.8.1. and 7.2.8.2., an alternative method may be applied with the agreement of the Technical Service carrying out the test.
- 7.2.8.4. The ISOFIX attachment opening force to be measured shall be that needed to disengage the first connector.
- 7.2.8.5. The test shall be carried out on a new seat, and repeated on a seat that has been subjected to the cycling procedure specified in paragraph 6.7.5.1.

Figure 3

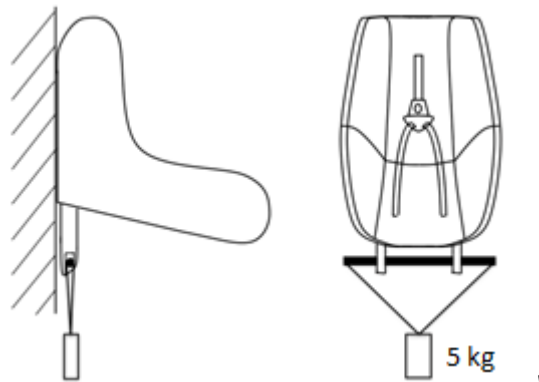

Paragraph 9.2., amend to read

"9.2. Qualifying the production of child restraint systems

The production of each new approved type of child restraint system of categories i-Size and specific to vehicle shall be subjected to production qualification tests. Additional qualifications of production may be prescribed following paragraph 11.1.3.

For this purpose..."

Insert a new paragraph 11.1.3., to read:

- "11.1.3. If a further test report is required, compare the horizontal head excursion result with the worst case from all results previously recorded:
- (a) If the excursion is greater, then new production qualification testing must be carried out;
 - (b) If the excursion is less, production qualification tests do not need to be carried out."

Paragraph 11.1.3.(former), renumber as paragraph 11.4.

Annex 2, amend to read:

"Annex 2

Arrangements of the approval mark

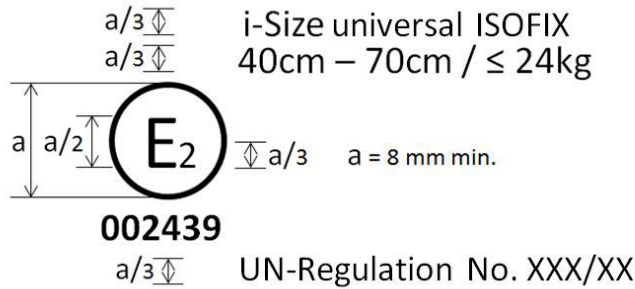

The child restraint system bearing the above approval mark is a device capable of being fitted in any i-size compatible vehicle seating position and of being used for the 40 cm to 70 cm size range and mass limit of 24 kg; it is approved in France (E2) under the number 002439. The approval number indicates that the approval was granted in accordance with the requirements of the Regulation concerning the approval of enhanced Child Restraint Systems used onboard of motor vehicles as amended by the 00 series of amendments. In addition the name of the regulation has to be identified on the approval mark followed by the series of amendment according to which the approval has been granted.

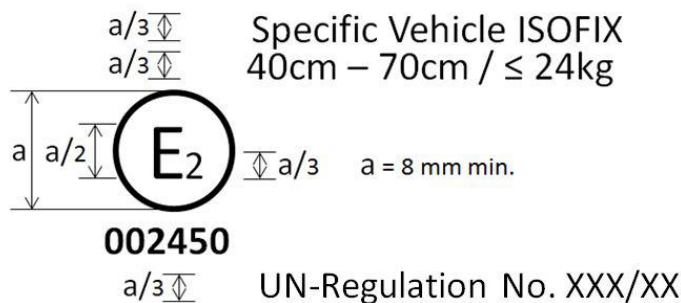

The child restraint system bearing the above approval mark is a device not capable of being fitted in every vehicle and of being used for the 40 cm to 70 cm size range and mass limit of 24 kg; it is approved in France (E2) under the number 002450. The approval number indicates that the approval was granted in accordance with the requirements of the Regulation concerning the approval of specific vehicle ISOFIX child restraint systems used on board of motor vehicles as amended by the 00 series of amendments. In addition, the name of the regulation has to be identified on the approval mark followed by the series of amendment according to which the approval has been granted.

Note: the approval..."

Annex 6 - Appendix 1,

Figures 1 and 2, amend to read:

"Figure 1

Dimensions of the seat and the seat cushions

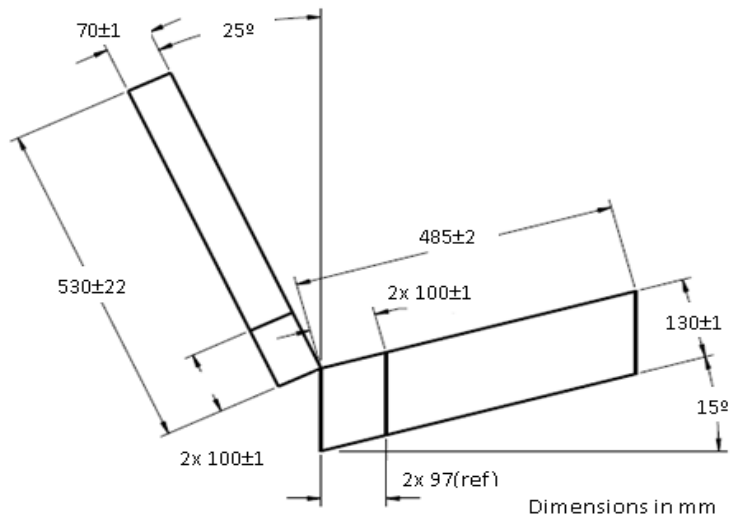
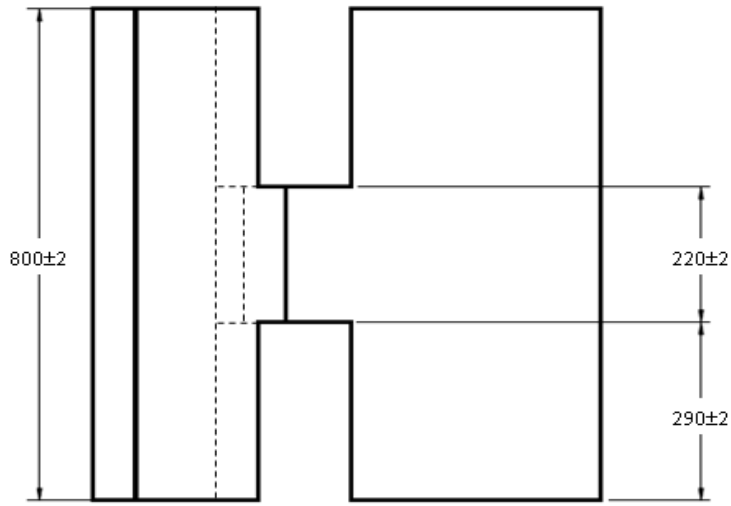

Figure 2
Dimensions of the aluminum bottom-plate

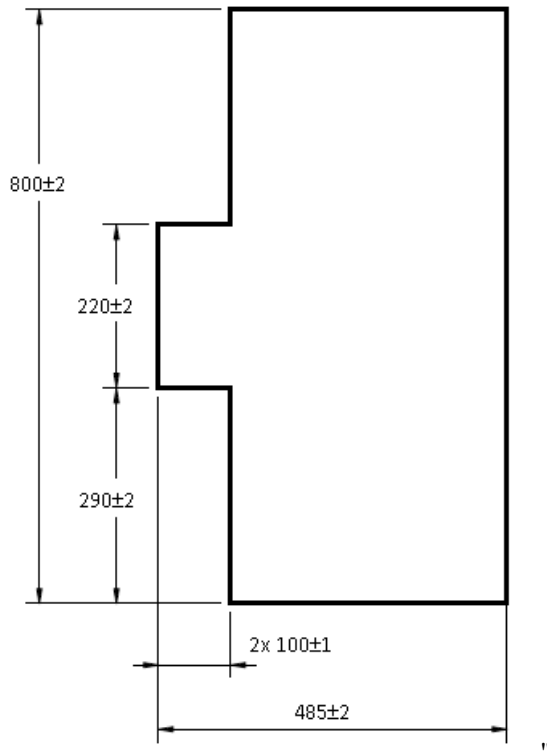
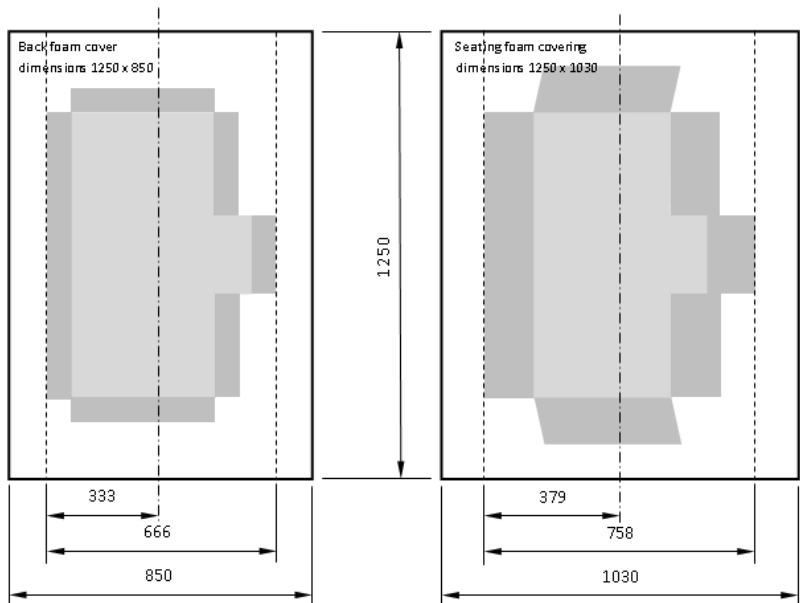

Figure 3, shall be deleted

Figure 4 (former), renumber as Figure 3 and amend to read:

"Figure 3
Dimensions of the cover material (dimensions in mm)



Annex 13,

Paragraphs 3.1. and 3.2., amend to read:

- "3.1. The child restraint shall be placed in the region of impact on a rigid flat surface, whose minimum dimensions are 500 x 500 mm, so that the direction of impact is perpendicular to the inner surface of the child restraint system in the area of impact."

Paragraph 3.3. (former), renumber as paragraph 3.2.

Annex 14, paragraph 1, amend to read:

- "1. Place the device on the test seat described in Annex 6. Reclinable devices shall be set in the most upright position. Place the smallest manikin in the device in accordance with the manufacturer's instructions. Mark a point "A" on the backrest on the same horizontal level as the shoulder of the smallest manikin at a point 2 cm inside the outer edge of the arm. All internal surfaces above the horizontal plane passing through point A, shall be tested in accordance with Annex 17. This area shall include the backrest and side wings, including the inner edges (zone of radius) of the side wings. In the case of carrycot devices where a symmetrical installation of the dummy is not possible according to the device and manufacturer instructions, the area complying with Annex 17 shall be all internal surfaces above a point "A", as previously defined, in the head direction, when measured with this dummy in the carrycot in its worst position consistent with the manufacturer instructions and the carrycot positioned on the test bench.

If a symmetrical installation of the dummy in the carrycot may be possible, the whole inner area shall comply with Annex 13."

Annex 17,

Paragraphs 1.2.1., the reference to footnote ¹ shall be deleted.

Paragraphs 1.3., the reference to footnote ² and footnote ² shall be deleted.

Annex 19, amend to read:

"Annex 19

Assessment volumes for i-size support-legs and support-leg feet

Figure 1
Side view of the support leg dimension assessment volume

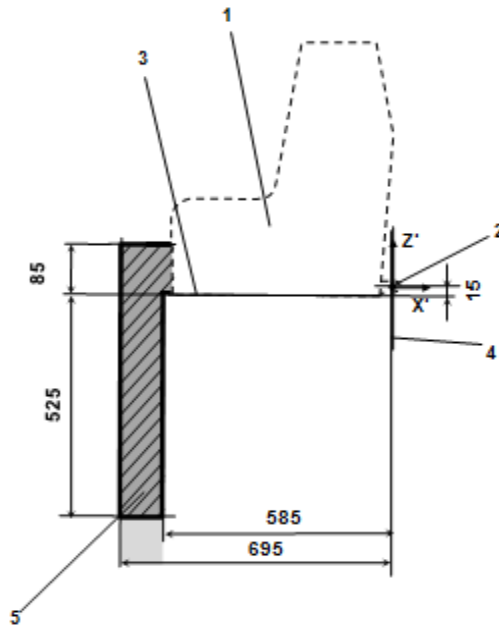

Key:

1. Child Restraint Fixture (CRF).
2. ISOFIX low anchorages bar.
3. Plane formed by the bottom surface of the CRF, which is parallel to and 15 mm below the X'-Y' plane of the coordinate system.
4. Z'-Y' plane of the coordinate system.
5. Upper part of the support-leg dimension assessment volume, which shows the dimensional limitations in X' and Y' direction, the upper height limit in Z' direction, as well as the lower height limitation in Z' direction for rigid, not in Z' direction adjustable support leg components.

Note:

1. Drawing not to scale.

Figure 2
3D view of the support leg dimension assessment volume

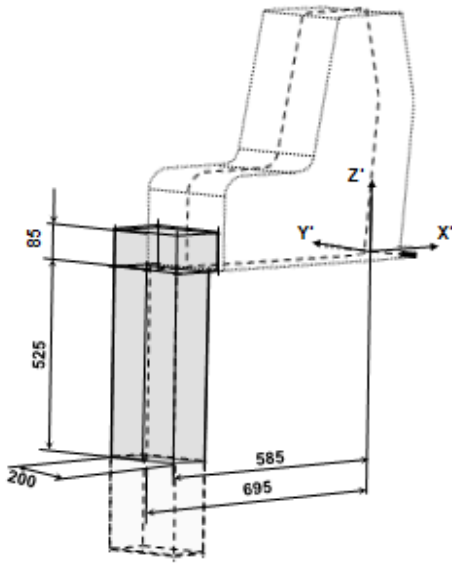

Note:

1. Drawing not to scale.

Figure 3
Side view of the support leg foot assessment volume

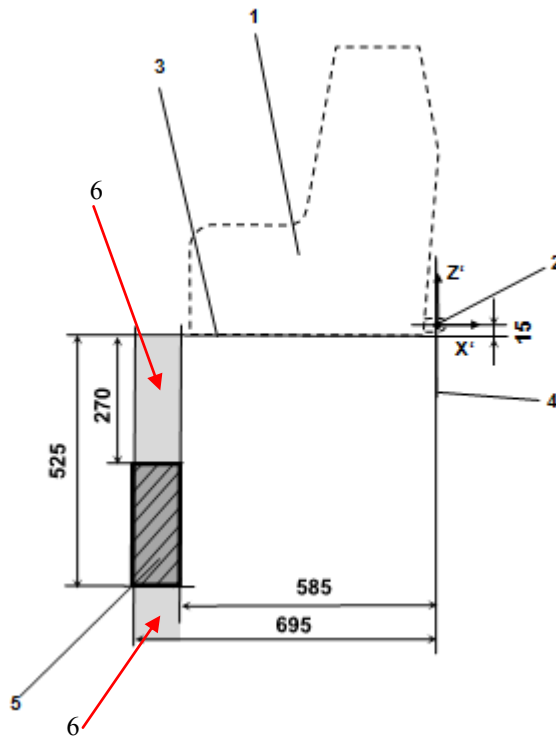

Key:

1. Child Restraint Fixture (CRF)
2. ISOFIX low anchorages bar
3. Plane formed by the bottom surface of the CRF, which is parallel to and 15 mm below the X'-Y' plane of the coordinate system
4. Z'-Y' plane of the coordinate system
5. Support-leg foot assessment volume, which shows the required adjustment range of the support-leg foot in Z' directions, as well as the dimensional limitations in X' and Y' direction
6. Additional volumes shows the additional permissible adjustment range in Z' direction for the support-leg foot

Note:

1. Drawing not to scale.

Figure 4
3D view ..."

Insert new Annex 21, to read:

"Annex 21

Load application device I

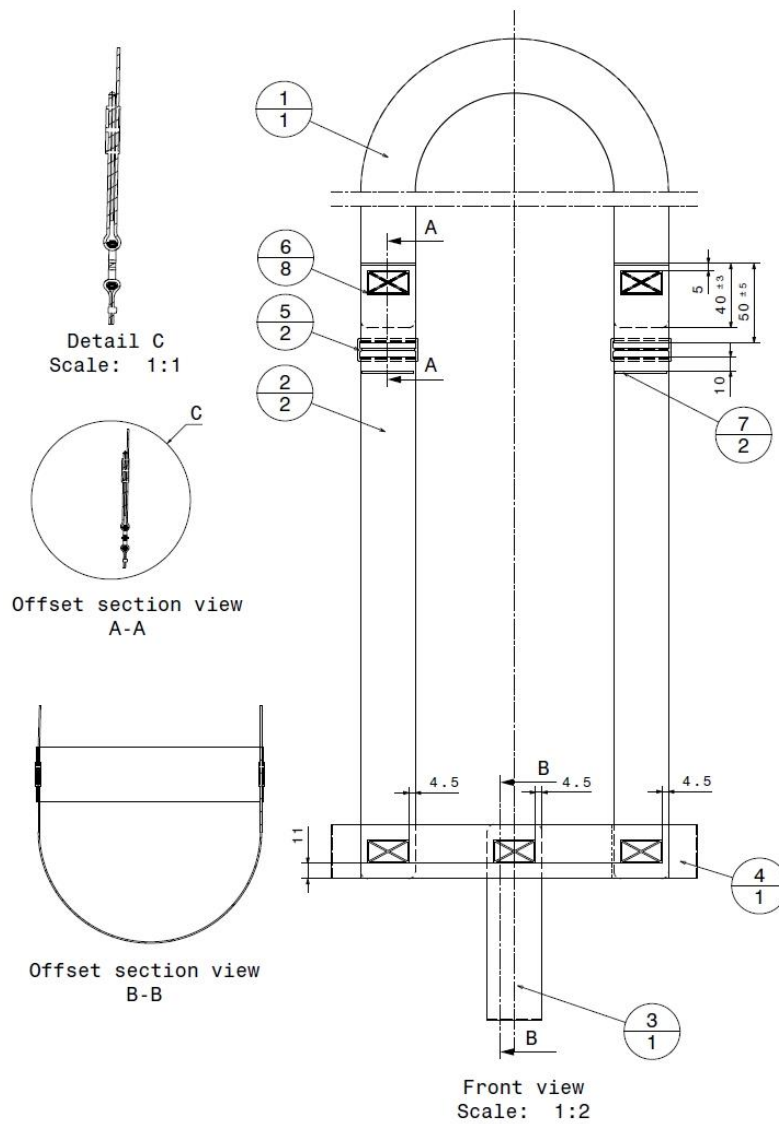

No.	Part Number	Name	Information	Quantity
1	PV000009.1	Head belt – 39 mm	-	1
2	PV000009.2	Shoulder belt lh-rh – 39 mm	-	2
3	PV000009.3	Crotch belt – 39 mm	-	1
4	PV000009.4	Hip belt – 39 mm	-	1
5	102 18 31	Stitch pattern (30 x 17)	Stich: 77, thread: 30, colour: SABA grey	8
6	PV000009.5	Plastic buckle		2
7	PV000009.6	Stitch pattern (2 x 37)	Stich: 77, thread: 30, colour: SABA grey	2

Strech lenght	(+/- 5 mm)					
	Dummy Q 0	Q 1	Q 1,5	Q 3	Q 6	Q 10
Head belt	1 000 mm	1 000 mm	1 000 mm	1 200 mm	1 200 mm	1 200 mm
Shoulder belt	750 mm	850 mm	950 mm	1 000 mm	1 100 mm	1 300 mm
Crotch belt	300 mm	350 mm	400 mm	400 mm	450 mm	570 mm
Hip belt	400 mm	500 mm	550 mm	600 mm	700 mm	800 mm
Dimension X	120 mm	130 mm	140 mm	140 mm	150 mm	1 600 mm

Belt			
Width	Thickness	Expansion	Fastness
39 mm +/- 1 mm	1 mm +/- 0,1 mm	5,5 – 6,5 %	Min. 15 000 N

Stich pattern	Min. required force
12 x 12 mm	3,5 kN
30 x 12 mm	5,3 kN
30 x 17 mm	5,3 kN
30 x 30 mm	7,0 kN

all belt radius = 5 mm

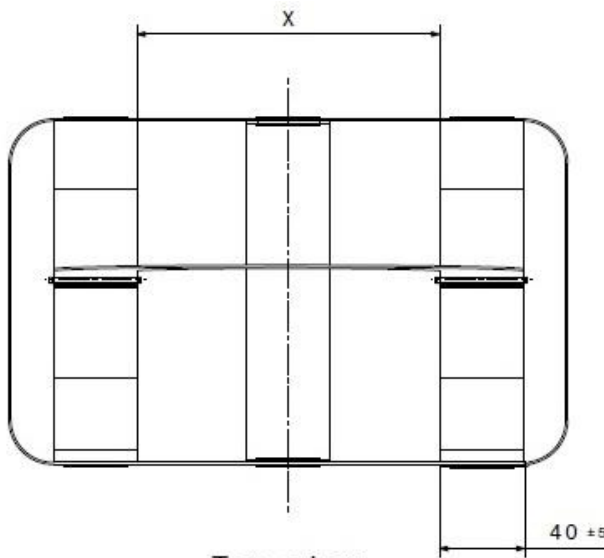

Top view
Scale:1:2



Isometric view
Scale:1:10

Load application device II

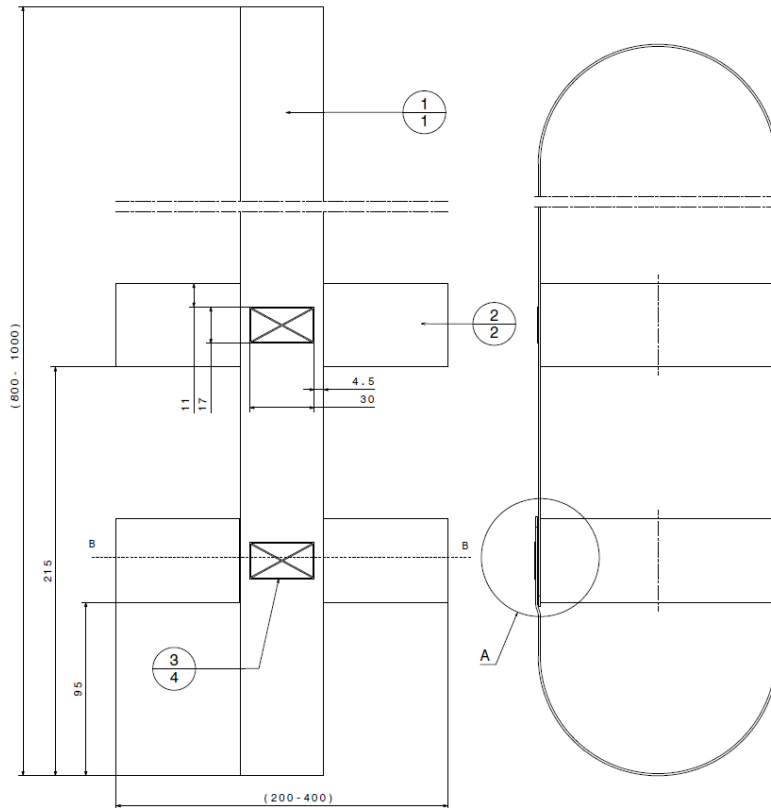

No.	Name	Information	Quantity
1	Main belt – 39 mm	-	1
2	Hip belt (upper/lower)– 39 mm	-	2
3	Stitch pattern (30 x 17)	Stich: 77, thread: 30-	4

Strech lenght	(± 5 mm)					
	Q 0	Q 1	Q 1,5	Q 3	Q 6	Q 10
Main belt (A)	1 740 mm	1 850 mm	1 900 mm	2 000 mm	2 000 mm	2 100 mm
Hip belt (B)	530 mm	560 mm	600 mm	630 mm	660 mm	700 mm
Lower dimension (C)	125 mm	150 mm	150 mm	170 mm	200 mm	200 mm
Mid dimension (D)	270 mm	300 mm	350 mm	380 mm	380 mm	400 mm

Belt	Width	Thickness	Expansion	Fastness
	39 mm ± 1 mm	1 mm ± 0,1 mm	5,5 – 6,5 %	Min. 15 000 N

Stich pattern	Min. required force
12 x 12 mm	3,5 kN
30 x 12 mm	5,3 kN
30 x 17 mm	5,3 kN
30 x 30 mm	7,0 kN

all belt radius = 5 mm

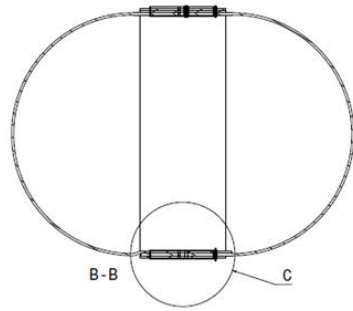
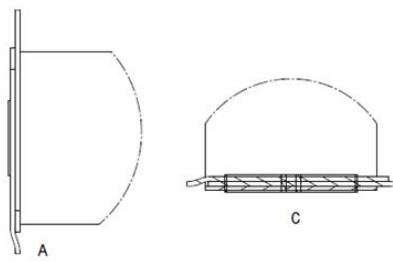

Top view
Scale:1:2



Isometric view
Scale:1:10 "