

Committee of Experts on the Transport of Dangerous Goods and on the Globally Harmonized System of Classification and Labelling of Chemicals

Sub-Committee of Experts on the Transport of Dangerous Goods

3 September 2013

Forty-fourth session

Geneva, 25 November – 4 December 2013

Item 11 of the provisional agenda

Other business

Review of the Manual of Tests and Criteria

Transmitted by the Chairman of the Working Group on Explosives

Introduction

1. In document ST/SG/AC.10/C.3/2013/43 proposals for the improvement of Test Series A, C and E and the corresponding tests in Test Series 1, 2, 8 and Appendix 7 are given. This informal document gives the proposal changes to the current text of the Manual of Tests and Criteria highlighted with “track changes”. The full text is given on the next pages.
 2. In order to keep the size of this document manageable the description of Test 1(c)(i), Test 2(c)(i), Appendix 7, Tests 1(b), Test 2(b) and Test 8(c) is not reproduced in this document. The applicable sections are specifically mentioned in document .../C.3/2013/43.
 3. Comprehensive changes to all tests involved will either be given in the Annex to the report of the Working Group on Explosives on the 45th session or will be the subject of a separate paper for the 46th session.
-

SECTION 11

TEST SERIES 1

11.1 Introduction

11.1.1 The question "Is it an explosive substance?" (box 4 of Figure 10.2) is answered on the basis of ~~national and international definitions of an explosive substance and~~ the results of three types of test to assess possible explosive effects. The question in box 4 is answered "yes" if a "+" is obtained in any of the three types of test.

11.2 Test methods

Test Series 1 is comprised of three types of test:

- Type 1 (a): for determining propagation of detonation;
- Type 1 (b): for determining the effect of heating under confinement; and
- Type 1 (c): for determining the effect of ignition under confinement

The test methods currently used are listed in Table 11.1.

Table 11.1: TEST METHODS FOR TEST SERIES 1

| Test code | Name of Test | Section |
|------------|---------------------------------|---------|
| 1 (a) | UN gap test ^a | 11.4.1 |
| 1 (b) | Koenen test ^a | 11.5.1 |
| 1 (c) (i) | Time/pressure test ^a | 11.6.1 |
| 1 (c) (ii) | Internal ignition test | 11.6.2 |

^a *Recommended test*

11.3 Test conditions

11.3.1 As the apparent density of the substance has an important effect on the results from the type 1 (a) test, it should always be recorded. The apparent density of solids should be determined from measurement of the tube volume and sample mass.

11.3.2 If a mixture can separate out during transport, handling and storage, the test should be performed with the initiator in contact with the potentially most explosive part, if known.

11.3.3 The tests should be performed at ambient temperature unless the substance is to be transported under conditions where it may change its physical state or density.

11.3.4 If a liquid is being considered for transport in tank-containers, or intermediate bulk containers with a capacity exceeding 450 litres, a cavitated version of the type 1 (a) test should be performed (see special provision 26 of Chapter 3.3 of the Model Regulations).

11.3.5 For organic substances and mixtures of organic substances with a decomposition energy of 800 J/g or more, test 1 (a) need not be performed if the outcome of the ballistic mortar Mk.IIIId test (F.1), or the ballistic mortar test (F.2) or the BAM Trauzl test (F.3) with initiation by a standard No. 8 detonator (see Appendix 1) is "No". In this case, the result of test 1 (a) is deemed to be "-". If the outcome of the F.1 or F.2 or F.3 test is "Low" or "Not low", the result of test 1 (a) shall be deemed "+". In this case, a "-" can only be obtained by performing test 1 (a).

11.4 Series 1 type (a) test prescription

11.4.1 Test 1 (a): UN gap test

11.4.1.1 Introduction

This test is used to measure the ability of a substance, under confinement in a steel tube, to propagate a detonation by subjecting it to the detonation from a booster charge.

11.4.1.2 Apparatus and materials

11.4.1.2.1 Solids

The apparatus for solids is shown in Figure 11.4.1.1. The test sample is contained in a ~~cold-drawn~~, seamless, carbon steel tube with an external diameter of 48 ± 2 mm, a wall thickness of 4.0 ± 0.1 mm and a length of 400 ± 5 mm. If the test substance may react with the steel, the inside of the tube may be coated with fluorocarbon resin. The bottom of the tube is closed with ~~a plastics two layers of 0.08 mm thick polythene~~ sheet pulled tightly (so that it plastically deforms) over the bottom of the tube and held tightly in place ~~with rubber bands and insulating tape. For samples which affect polythene, polytetrafluoroethylene sheet can be used. The plastics sheet shall be compatible with the substance under test.~~ The booster charge consists of 160 g RDX/wax (95/5) or PETN/TNT (50/50), 50 ± 1 mm in diameter with a density of $1\ 600 \pm 50$ kg/m³ giving a length of about 50 mm. The ~~RDX/wax~~ charges may be pressed in one or more pieces, as long as the total charge is within the specifications, ~~and the PETN/TNT charge is cast. A mild steel witness plate, 150 ± 10 mm square and 3.2 ± 0.2 mm thick, is mounted at the upper end of the steel tube and separated from it by spacers 1.6 ± 0.2 mm thick.~~

11.4.1.2.2 Liquids

The apparatus for liquids is the same as that for solids. When a cavitated version of the test is performed (see 11.3.4), one of the methods of cavitation given in Appendix 3 may be used.

11.4.1.3 Procedure

11.4.1.3.1 The sample is loaded to the top of the steel tube. Solid samples are loaded to the density attained by tapping the tube until further settling becomes imperceptible. The sample mass is determined and, if solid, the apparent density calculated using the measured internal volume of the tube. ~~The density should be as close as possible to the shipping density.~~

11.4.1.3.2 The tube is placed in a vertical position and the booster charge is placed in direct contact with the sheet which seals the bottom of the tube. The detonator is fixed in place against the booster charge and initiated. Two tests should be performed unless detonation of the substance is observed.

11.4.1.4 Test criteria and method of assessing results

The test results are assessed on ~~the basis of the type of fragmentation length~~ length of the tube ~~and on whether a hole is punched through the witness plate~~. The test giving the most severe assessment should be used for classification. The test result is considered "+" and the substance to propagate detonation if:

~~————— The tube is fragmented completely.;~~ ~~or~~

~~————— A hole is punched through the witness plate.~~

Any other result is considered "-" and the substance is not able to propagate a detonation.

| Substances | Apparent density (kg/m³) | Fragmentation length (cm) | Witness plate | Result |
|---------------------------------|--|----------------------------------|----------------------|---------------|
| Ammonium nitrate, prills | 800 | 40 | Domed | + |
| Ammonium nitrate, 200 µm | 540 | 40 | Holed | + |
| Ammonium nitrate/fuel oil, 94/6 | 880 | 40 | Holed | + |
| Ammonium perchlorate, 200 µm | 1 190 | 40 | Holed | + |
| Nitromethane | 1 130 | 40 | Holed | + |
| Nitromethane/methanol, 55/45 | 970 | 20 | Domed | - |
| PETN/lactose, 20/80 | 880 | 40 | Holed | + |
| PETN/lactose, 10/90 | 830 | 17 | No damage | - |
| TNT, cast | 1 510 | 40 | Holed | + |
| TNT, flaked | 710 | 40 | Holed | + |
| Water | 1 000 | <40 | Domed | - |

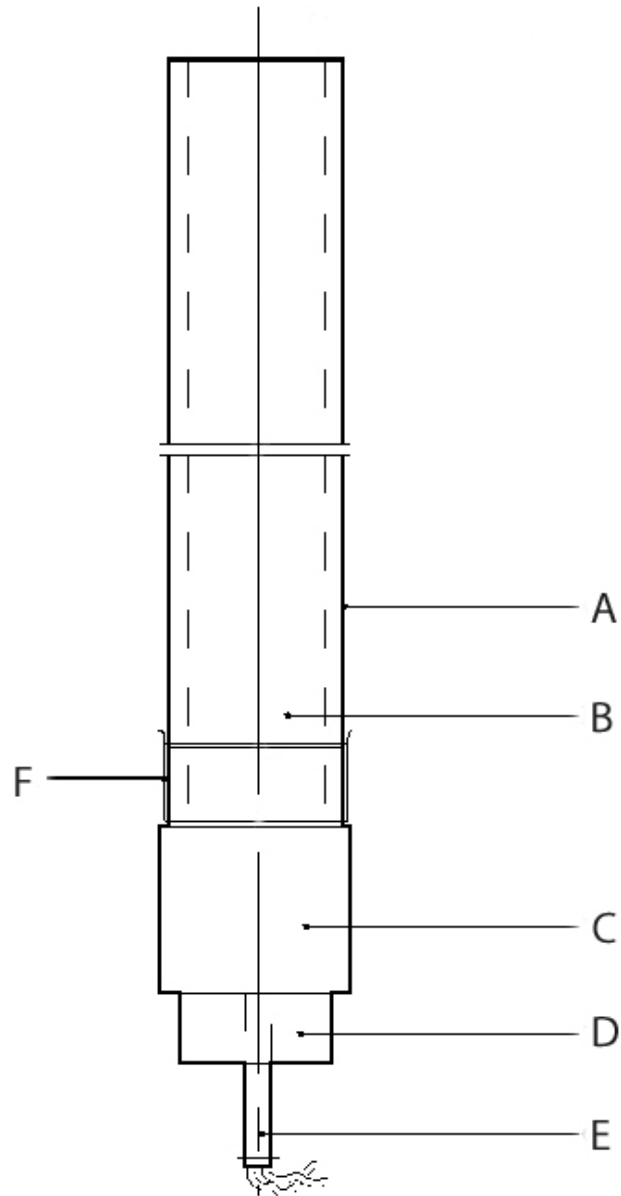

| | | | |
|-----------------|---|-----------------|--|
| (A) | Spacers | (B) | Witness plate |
| (CA) | Steel tube | (DB) | Substance under investigation |
| (EC) | RDX/wax or PETN/TNT booster charge | (FD) | Detonator holder |
| (GE) | Detonator | (HF) | Plastics membrane |

Figure 11.4.1.1: UN GAP TEST

SECTION 12

TEST SERIES 2

12.1 Introduction

12.1.1 The question "Is the substance too insensitive for inclusion in Class 1?" (box 6 of Figure 10.2) is answered on the basis of three types of test to assess possible explosive effects. The question in box 6 is answered "no" if a "+" is obtained in any of the three types of test.

12.2 Test methods

Test Series 2 comprises three types of test:

Type 2 (a): for determining sensitivity to shock;

Type 2 (b): for determining the effect of heating under confinement; and

Type 2 (c): for determining the effect of ignition under confinement

The test methods currently used are listed in table 12.1.

Table 12.1: TEST METHODS FOR TEST SERIES 2

| Test code | Name of Test | Section |
|------------|---------------------------------|---------|
| 2 (a) | UN gap test ^a | 12.4.1 |
| 2 (b) | Koenen test ^a | 12.5.1 |
| 2 (c) (i) | Time/pressure test ^a | 12.6.1 |
| 2 (c) (ii) | Internal ignition test | 12.6.2 |

^a *Recommended test.*

12.3 Test conditions

12.3.1 As the apparent density of the substance has an important effect on the results from the type 2 (a) test, it should always be recorded. The apparent density of solids should be determined from measurement of the tube volume and sample mass.

12.3.2 If a mixture can separate out during transport, the test should be performed with the initiator in contact with the potentially most explosive part if known.

12.3.3 The tests should be performed at ambient temperature unless the substance is to be transported under conditions where it may change its physical state or density.

12.3.4 For organic substances and mixtures of organic substances with a decomposition energy of 800 J/g or more, test 2 (a) need not be performed if the outcome of the ballistic mortar Mk.III d test (F.1), or the ballistic mortar test (F.2) or the BAM Trauzl test (F.3) with initiation by a standard No. 8 detonator (see Appendix 1) is "No". In this case, the result of test 2 (a) is deemed to be "-". If the outcome of the F.1 or F.2 or F.3 test is "Low" or "Not low", the result of test 2 (a) shall be deemed "+". In this case, a "-" can only be obtained by performing test 2 (a).

12.4 Series 2 type (a) test prescription

12.4.1 Test 2 (a): UN gap test

12.4.1.1 Introduction

This test is used to measure the sensitivity of a substance, under confinement in a steel tube, to detonative shock.

12.4.1.2 Apparatus and materials

The apparatus is shown in Figure 12.4.1.1. The test sample is contained in ~~a cold-drawn,~~ seamless, carbon steel tube with an external diameter of 48 ± 2 mm, a wall thickness of 4.0 ± 0.1 mm and a length of 400 ± 5 mm. If the test substance may react with the steel, the inside of the tube may be coated with fluorocarbon resin. The bottom of the tube is closed with ~~a plastics two layers of 0.08 mm thick polythene sheet pulled tightly (so that it plastically deforms) over the bottom of the tube and held tightly in place with rubber bands and insulating tape. For samples which affect polythene, polytetrafluoroethylene sheet can be used. The plastics sheet shall be compatible with the substance under test.~~ The booster charge consists of 160 g RDX/wax (95/5) or PETN/TNT (50/50), 50 ± 1 mm in diameter with a density of $1\,600 \pm 50$ kg/m³ giving a length of about 50 mm. The ~~RDX/wax charges~~ may be pressed in one or more pieces, as long as the total charge is within the specifications, ~~and the PETN/TNT charge is cast.~~ A polymethyl methacrylate (PMMA) spacer is required of diameter 50 ± 1 mm and length 50 ± 1 mm. ~~A mild steel witness plate, 150 ± 10 mm square and 3.2 ± 0.2 mm thick, is mounted at the upper end of the steel tube and separated from it by spacers 1.6 ± 0.2 mm thick.~~

12.4.1.3 Procedure

12.4.1.3.1 The sample is loaded to the top of the steel tube. Solid samples are loaded to the density attained by tapping the tube until further settling becomes imperceptible. The sample mass is determined and, if solid, the apparent density calculated using the measured internal volume of the tube. ~~The density should be as close as possible to the shipping density.~~

12.4.1.3.2 The tube is placed in a vertical position and the PMMA spacer placed in direct contact with the sheet which seals the bottom of the tube. After positioning the booster charge in contact with the PMMA spacer, the detonator is fixed in place against the bottom of the booster charge and initiated. Two tests should be performed unless detonation of the substance is observed.

12.4.1.4 Test criteria and method of assessing results

The test results are assessed on the ~~basis of the type of fragmentation~~ length of the tube ~~and whether the witness plate is holed.~~ The test giving the most severe assessment should be used for classification. The test result is considered "+" and the substance is considered to be sensitive to shock if:

~~_____~~ (a) ~~The tube is fragmented completely, or~~

~~_____~~ (b) ~~The witness plate is holed.~~

Any other result is considered "-" and the substance is considered to be not sensitive to detonative shock.

| Substances | Apparent density (kg/m³) | Fragmentation length (cm) | Witness plate | Result |
|---------------------------------|--|----------------------------------|----------------------|---------------|
| Ammonium nitrate, prills | 800 | 25 | Domed | - |
| Ammonium nitrate, 200 µm | 540 | 40 | Holed | + |
| Ammonium nitrate/fuel oil, 94/6 | 880 | 40 | Holed | + |
| Ammonium perchlorate, 200 µm | 1 190 | 0 | No damage | - |
| Nitromethane | 1 130 | 0 | No damage | - |
| PETN/lactose, 20/80 | 880 | 40 | Holed | + |
| TNT, cast | 1 510 | 20 | No damage | - |
| TNT, flaked | 710 | 40 | Holed | + |

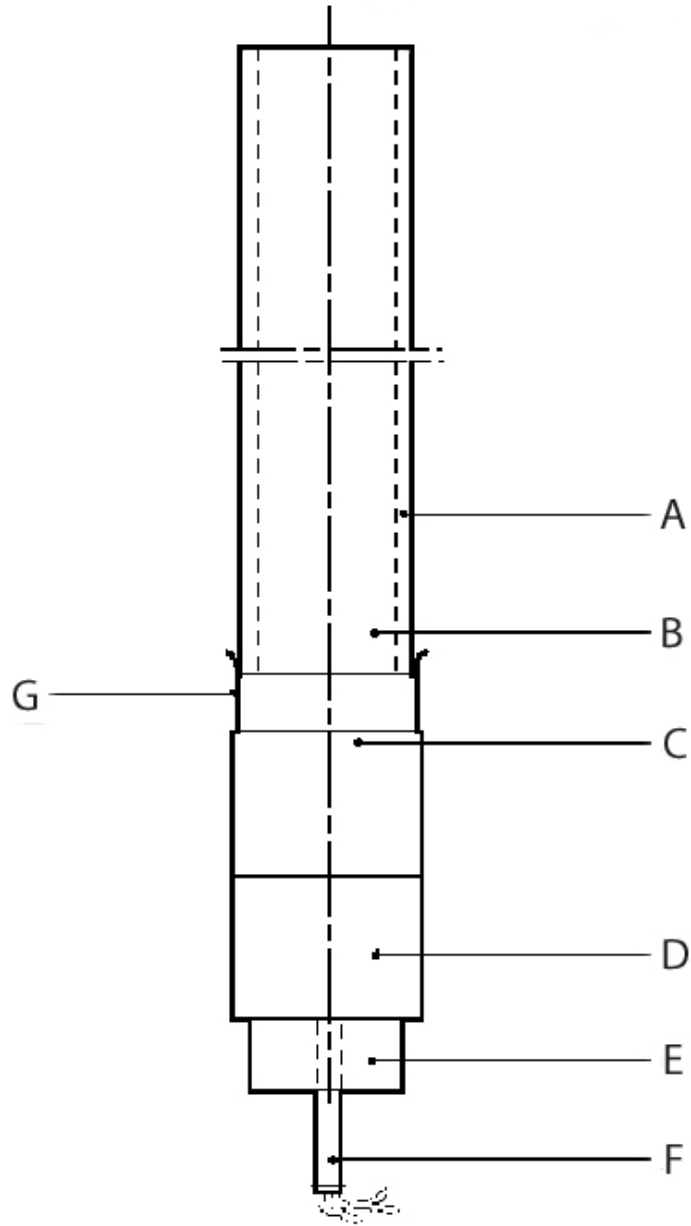

| | |
|--------------------------------------|---|
| (A) (A) Spacers | (B) (B) Witness plate |
| (C) (C) Steel tube | (D) (D) Substance under investigation |
| (E) (E) PMMA spacer | (F) (F) RDX/wax or PETN/TNT booster charge |
| (G) (G) Detonator holder | (H) (H) Detonator |
| (I) (I) Plastics membrane | |

Figure 12.4.1.1: UN GAP TEST

SECTION 21

TEST SERIES A

21.1 Introduction

20.1.1 Test series A comprises ~~laboratory~~ tests and criteria concerning propagation of detonation as requested in box 1 of Figure 20.1.

21.2 Test methods

21.1.2 The question "Does it propagate a detonation?" (box 1 of Figure 20.1) is answered on the basis of the results of one of the test methods in Table 21.1. If a liquid is being considered for transport in tank-containers or IBCs with a capacity exceeding 450 litres, a cavitated version of a Series A test ~~may~~ should be ~~performed~~used (see Appendix 3).

Table 21.1: TEST METHODS FOR TEST SERIES A

| Test code | Name of test | Section |
|----------------|--------------------------------------|-------------------|
| A.1 | BAM 50/60 steel tube test | 21.4.1 |
| A.2 | TNO 50/70 steel tube test | 21.4.2 |
| A.5 | UN gap test | 21.4.3 |
| A.6 | UN detonation test ^a | 21.4.4 |

^a *Recommended test*

All tests are considered to be equivalent and only one test method has to be used.

21.2.2 For organic peroxides and self-reactive substances, a combination of a test for explosive power (any test of series F except test F.5 for peroxides, and any test of series F except tests F.4 and F.5 for self-reactive substances) with two tests for the effects of heating under confinement may be used as a screening procedure for assessing the ability to propagate a detonation. A test of series A need not be performed if:

- (a) A "No" result is obtained from the explosive power test; and
- (b) A "No" or "Low" result is obtained from test E.2 and either test E.1 or E.3.

For transport in packages (excluding IBCs), if the screening procedure indicates that a Series A test is not needed, the question in box 1 is answered with a "No". However, if the substance is being considered for transport in tank containers or IBCs, or for exemption, then a series A test is required unless the result of a series A test on a formulation of the substance with a higher concentration and the same physical state is "No".

21.3 Test conditions

21.3.1 As the apparent density of the substance has an important effect on the results from series A tests, it should always be recorded. The apparent density of solids should be determined from measurement of the tube volume and sample mass.

21.3.2 If a mixture can separate out during transport, the test should be performed with the initiator in contact with the potentially most explosive part if known.

21.3.3 The tests should be performed at ambient temperature unless the substance is to be transported under conditions where it may change its physical state or density. Organic peroxides and self-reactive substances which require temperature control should be tested at the control temperature if below ambient temperature.

21.3.4 The preliminary procedure should be performed before performing these tests (see section 20.3).

21.3.5 When a fresh batch of steel tubes is used, calibration tests using water (for tests on liquids) and an inert, organic solid (for tests on solids) should be performed to determine the average blank fragmentation length. The "No" / "Partial" criteria should be set to 1.5 times the average blank fragmentation length.

21.4 Series A test prescriptions**21.4.1 Test A.1: BAM 50/60 steel tube test (to be checked by BAM)**21.4.1.1 *Introduction*

This test is used to measure the ability of a substance to propagate a detonation by subjecting it to a detonating booster charge under confinement in a steel tube. It may be used to answer the question in box 1 of Figure 20.1.

21.4.1.2 *Apparatus and materials*

A seamless drawn steel tube of 500 mm length, 60 mm external diameter and 5 mm wall-thickness (e.g. according to DIN 2448) should be used, made from steel St 37.0 with tensile strength of 350 to 480 N.mm⁻² (e.g. according to DIN 1629). The tube is closed by a malleable cast iron screwing cap or by an appropriate plastic cap, put over the open end of the tube. The booster consists of a cylindrical pellet of 50 g RDX/wax (95/5) compressed to a pressure of 1 500 bar and with dimensions shown in Figure 21.4.1.1. The upper part of the booster has an axial recess of 7 mm diameter and 20 mm depth which accepts a detonator of sufficient strength to initiate the booster reliably. Substances which may react dangerously with steel St. 37.0 are tested in tubes with an internal polythene coating¹.

21.4.1.3 *Procedure*

21.4.1.3.1 Normally, the steel tube is filled with the substance as received, the sample mass determined and, if solid, the apparent density calculated using the measured internal tube volume. However, lumps are crushed and paste-like or gel-type substances are carefully packed to eliminate voids. In all cases, the final density of the substance in the tube should be as close as possible to its shipping density. The booster is placed centrally in the upper end of the tube, so that it is surrounded by the substance. When liquids are tested, the booster is separated from the liquid by wrapping it in a thin foil of aluminium or an appropriate plastic material. The wrapped booster is then attached to the malleable iron cap by means of thin wires passing through four additional drillings in the cap. The cap is carefully screwed onto the tube and the detonator inserted into the booster through the central hole in the screw cap. The detonator is then initiated.

21.4.1.3.2 At least two tests, which may be instrumented (e.g. by a continuous velocity probe), are performed unless detonation of the substance is observed. An instrumented third test may be necessary if no conclusion can be drawn from two uninstrumented tests.

21.4.1.4 *Test criteria and method of assessing results*

21.4.1.4.1 The test results are assessed on the basis of:

- (a) The type of fragmentation of the tube;
- (b) The completeness of the reaction of the substance; and
- (c) If the occasion arises, the measured rate of propagation in the substance.

The test giving the most severe assessment should be used for classification.

¹ In special cases, pure aluminium or steel 1.4571 according to DIN 17440 may be used as tube material.

21.4.1.4.2 The test criteria are as follows:

- "Yes":
- The tube is fragmented completely; or
 - The tube is fragmented at both ends; or
 - A velocity measurement shows that the rate of propagation in the non-fragmented part of the tube is constant and above the velocity of sound in the substance.
- "Partial":
- The tube is fragmented only at the initiator end and the average tube fragmentation length (average over two tests) is greater than 1.5 times the average fragmentation length found with an inert material having the same physical state; and
 - A significant portion of unreacted substance remains or a velocity measurement shows that the rate of propagation in the non-fragmented part of the tube is lower than the velocity of sound in the substance.
- "No":
- The tube is fragmented only at the initiator end and the average fragmentation length (average of two tests) not more than 1.5 times the average fragmentation length found with an inert material having the same physical state; and
 - A significant portion of unreacted substance remains or a velocity measurement shows that the rate of propagation in the non-fragmented part of the tube is lower than the velocity of sound in the substance.

| Substances | Apparent density (km/m ³) | Fragmented length (cm) | Result |
|--|---------------------------------------|------------------------|------------------|
| Azodicarbonamide | 627 | 15 | No |
| 2,2'-Azodi(2,4-dimethylvaleronitrile) | 793 | 16 | No |
| Benzene-1,3-disulphohydrazide | 640 | 50 | Yes |
| Benzene sulphohydrazide | 630 | 17 | No |
| tert-Butyl peroxybenzoate | - | 30 | Partial |
| tert-Butyl peroxy-2-ethylhexanoate | - | 18 | No |
| 3-Chloroperoxybenzoic acid, not more than 86% with 3-chlorobenzoic acid | 610 | 24, 6 ^a | Yes |
| Cumyl hydroperoxide, 84% in cumene | - | 15 | No |
| Cyclohexanone peroxide(s) | 620 | 50 | Yes |
| 2-Diazo-1-naphthol-5-sulphochloride | 690 | 20 | No ^b |
| Dibenzoyl peroxide | 730 | 30, 12 ^a | Yes |
| Dibenzoyl peroxide, 75% with water | 740 | 20 | No |
| Di-tert-butyl peroxide | - | 16 | No |
| Dicetyl peroxydicarbonate | 590 | 13 | No |
| Dicumyl peroxide | 520 | 14 | No |
| Diisopropyl peroxydicarbonate | 790 | 50 | Yes |
| Dilauroyl peroxide | 580 | 25 | Partial |
| Dimyristyl peroxydicarbonate | 460 | 20 | No |
| Dimyristyl peroxydicarbonate, 42% stable dispersion in water | - | 15 | No |
| N,N'-Dinitrosopentamethylene tetramine, 90% with mineral oil | 590 | 50 | Yes ^c |
| N,N'-Dinitrosopentamethylene tetramine, 80% with 17% inorganic solid and 3% mineral oil | 500 | 50 | Yes |
| N,N'-Dinitrosopentamethylene tetramine, 75% with 15% calcium carbonate and 10% mineral oil | - | 26 | Partial |
| <i>Inert substances:</i> | | | |
| Air | | 8 | |
| Dimethyl phthalate | | 13 | |
| Icing sugar | 682 | 14 | |
| Sand | | 13 | |
| Water | | 14 | |

^a *Both ends fragmented.*

^b *Substance completely reacted by deflagration.*

^c *Detonation velocity 3 040 m/s.*

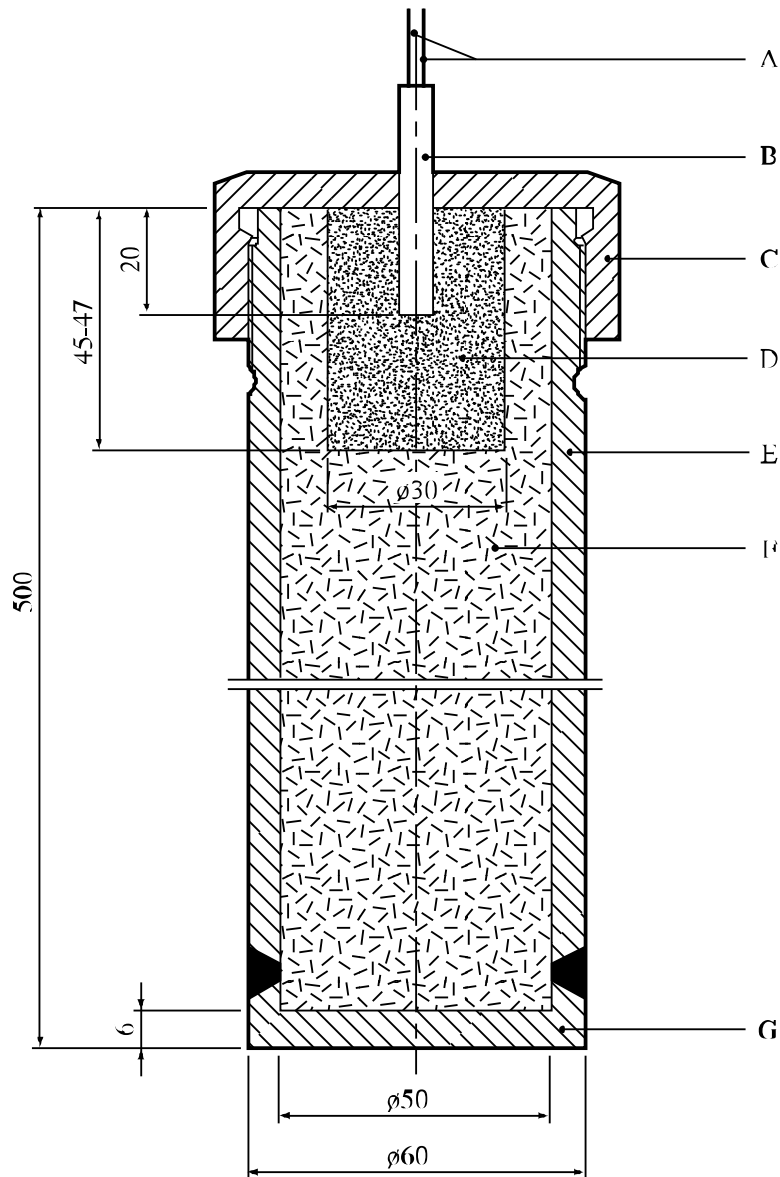

- (A) Detonator wires
- (B) Detonator inserted 20 mm into the booster charge
- (C) Screw cap of malleable cast iron or a plastics cap
- (D) Booster charge of RDX/wax (95/5) with 30 mm diameter and length of approximately 46 mm
- (E) Steel tube 500 mm long with internal diameter 50 mm, external diameter 60 mm
- (F) Substance under test
- (G) Welded steel based 6 mm thick

Figure 21.4.1.1: BAM 50/60 STEEL TUBE TEST

21.4.3 *Test A.5: UN gap test*

21.4.3.1 *Introduction*

This test is used to measure the ability of a substance to propagate a detonation by subjecting it to a detonating booster charge under confinement in a steel tube. It may be used to answer the question in box 1 of Figure 20.1.

21.4.3.2 *Apparatus and materials*

The apparatus is shown in Figure 21.4.3.1. The test sample is contained in ~~an annealed cold-drawn~~, seamless, carbon steel tube with an external diameter of 48 ± 2 mm, a wall thickness of 4.0 ± 0.1 mm and a length of 400 ± 5 mm. If the test substance may react with the steel, the inside of the tube may be coated with fluorocarbon resin. The bottom of the tube is closed with ~~a plastics two layers of 0.08 mm thick polythene~~ sheet pulled tightly (so that it plastically deforms) over the bottom of the tube and held tightly in place ~~with rubber bands and insulating tape. For samples which affect polythene, polytetrafluoroethylene sheet can be used. The plastics sheet shall be compatible with the substance under test.~~ The booster charge consists of 160 g RDX/wax (95/5) or PETN/TNT (50/50), 50 ± 1 mm in diameter with a density of $1\,600 \pm 50$ kg/m³ giving a length of about 50 mm. The ~~RDX/wax~~ charges may be pressed in one or more pieces, as long as the total charge is within the specifications, ~~and the PETN/TNT charge is cast. A mild steel witness plate, 150 ± 10 mm square and 3.2 ± 0.2 mm thick, is mounted at the upper end of the steel tube and separated from it by spacers 1.6 ± 0.2 mm thick.~~

21.4.3.3 *Procedure*

21.4.3.3.1 The sample is loaded to the top of the steel tube. Solid samples are loaded to the density attained by tapping the tube until further settling becomes imperceptible. The sample mass is determined and, if solid, the apparent density calculated using the measured internal volume of the tube. ~~The density should be as close as possible to the shipping density.~~

21.4.3.3.2 The tube is placed in a vertical position and the booster charge is placed in direct contact with the sheet which seals the bottom of the tube. The detonator is fixed in place against the booster charge and initiated. Two tests should be performed unless detonation of the substance is observed.

21.4.3.4 *Test criteria and method of assessing results*

21.4.3.4.1 The test results are assessed on the basis of the fragmentation pattern of the tube. ~~The witness plate is used only to provide supplemental information on the violence of the reaction.~~ The test giving the most severe assessment should be used for classification.

21.4.3.4.2 The test criteria are as follows:

- "Yes": - The tube is fragmented over its entire length.
- "Partial": - The tube is not fragmented over its entire length but the average tube fragmentation (average over the two tests) is greater than 1.5 times the average fragmentation length found with an inert material with the same physical state.
- "No": - The tube is not fragmented over its entire length and the average tube fragmentation (average over the two tests) is not more than 1.5 times the average fragmentation length found with an inert material with the same physical state.

21.4.3.5 *Examples of results*

| Substance | Apparent density (kg/m³) | Fragmented length (cm) | Result |
|--|--|-----------------------------------|---------------|
| 2,2'-Azodi(isobutyronitrile) | 366 | 40 | Yes |
| tert-Butyl peroxybenzoate | | 25 | Partial |
| tert-Butyl peroxy-2-ethylhexanoate | | 25 | Partial |
| Dibenzoyl peroxide, 75% with water | 685 | 40 | Yes |
| 2,5-Di-(tert-butylperoxy)-2,5-dimethylhexyne-3 | | 34 | Partial |
| Dilauroyl peroxide | 564 | 28 | No |

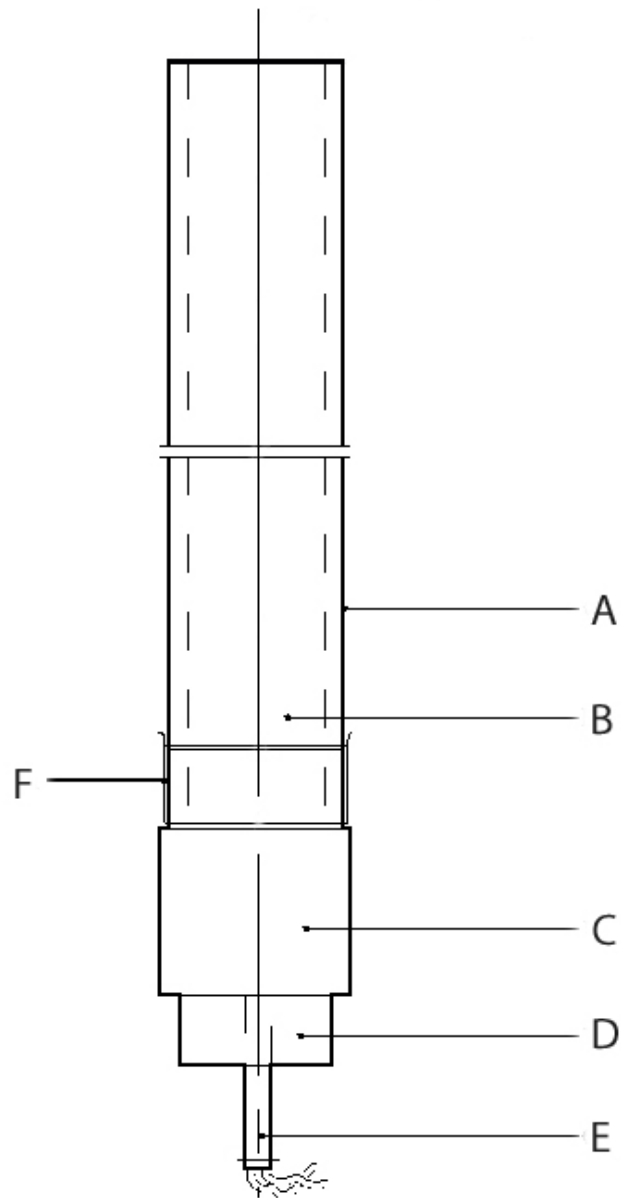

| | | | |
|-----------------|------------------------------------|-----------------|--------------------------|
| (A) | Spacers | (B) | Witness plate |
| (CA) | Steel tube | (DB) | Substance under test |
| (EC) | RDX/wax or PETN/TNT booster charge | (FD) | Detonator holder |
| (GE) | Detonator | (HF) | Plastics sheet |

Figure 21.4.3.1: UN GAP TEST

21.4.4 Test A.6: UN detonation test21.4.4.1 *Introduction*

This test is used to measure the ability of a substance to propagate a detonation by subjecting it to a detonating booster charge under confinement in a steel tube. It may be used to answer the question in box 1 of Figure 20.1.

21.4.4.2 *Apparatus and materials*

The apparatus is shown in Figure 21.4.4.1 and is identical for solids and liquids. The test sample is contained in an annealed cold drawn, seamless, carbon steel tube with an external diameter of 60 ± 1 mm, a wall thickness of 5 ± 1 mm and a length of 500 ± 5 mm. If the test substance may react with the steel, the inside of the tube may be coated with fluorocarbon resin. The bottom of the tube is closed with a plastics two layers of 0.08 mm thick polythene sheet held tightly in place ~~with rubber bands and insulating tape. For samples which affect polythene, polytetrafluoroethylene sheet can be used. The plastics sheet shall be compatible with the substance under test.~~ The booster charge is a 200 g RDX/wax (95/5) or PETN/TNT (50/50), 60 ± 1 mm in diameter and about 45 mm long with a density of $1\,600 \pm 50$ kg/m³. The ~~RDX/wax charges~~ may be pressed in one or more pieces as long as the total charge is within the specifications ~~and the PETN/TNT charge is cast.~~ The tube may be instrumented, e.g. by a continuous wire velocity probe, to measure the velocity of propagation in the substance. ~~Additional information on the explosive behaviour of the test sample can be gained by the use of a witness plate, as shown in Figure 21.4.4.1. The mild steel witness plate, 150 mm square and 3.2 mm thick, is mounted at the upper end of the tube and separated from it by spacers 1.6 mm thick.~~

21.4.4.3 *Procedure*

The sample is loaded to the top of the steel tube. Solid samples are loaded to the density attained by tapping the tube until further settling becomes imperceptible. The sample mass is determined and, if solid, the apparent density calculated. ~~The density should be as close as possible to the shipping density.~~ The tube is placed in a vertical position and the booster charge is placed in direct contact with the sheet which seals the bottom of the tube. The detonator is fixed in place against the booster charge and initiated. Two tests should be performed unless detonation of the substance is observed.

21.4.4.4 *Test criteria and method of assessing results*

~~_____~~ 21.4.4.4.1 The test results are assessed on the basis of ~~;~~

~~_____~~ ~~(a) The type of fragmentation of the tube;~~ and

~~_____~~ ~~(b) If the occasion arises, the measured rate of propagation in the substance.~~

The test giving the most severe assessment should be used for classification.

21.4.4.4.2 The test criteria are as follows:

- "Yes": - The tube is fragmented completely.
- "Partial": - The tube is not fragmented over its entire length but the average tube fragmentation (average over the two tests) is greater than 1.5 times the average fragmentation length found with an inert material with the same physical state.
- "No": - The tube is not fragmented over its entire length and the average tube fragmentation (average over the two tests) is not more than 1.5 times the average fragmentation length found with an inert material with the same physical state.

| Substance | Apparent density (kg/m³) | Fragmented length (cm) | Result |
|--|--|-----------------------------------|---------------|
| 2,2'-Azodi(isobutyronitrile) | 346 | 50 | Yes |
| tert-Butyl peroxybenzoate | | 28 | Partial |
| tert-Butyl peroxy-2-ethylhexanoate | | 23 | No |
| Dibenzoyl peroxide, 75% with water | 697 | 22 | No |
| 2,5-Di-(tert-butylperoxy)-2,5-dimethylhexyne-3 | 870 | 30 | Partial |
| Dilauroyl peroxide | 580 | 32 | Partial |

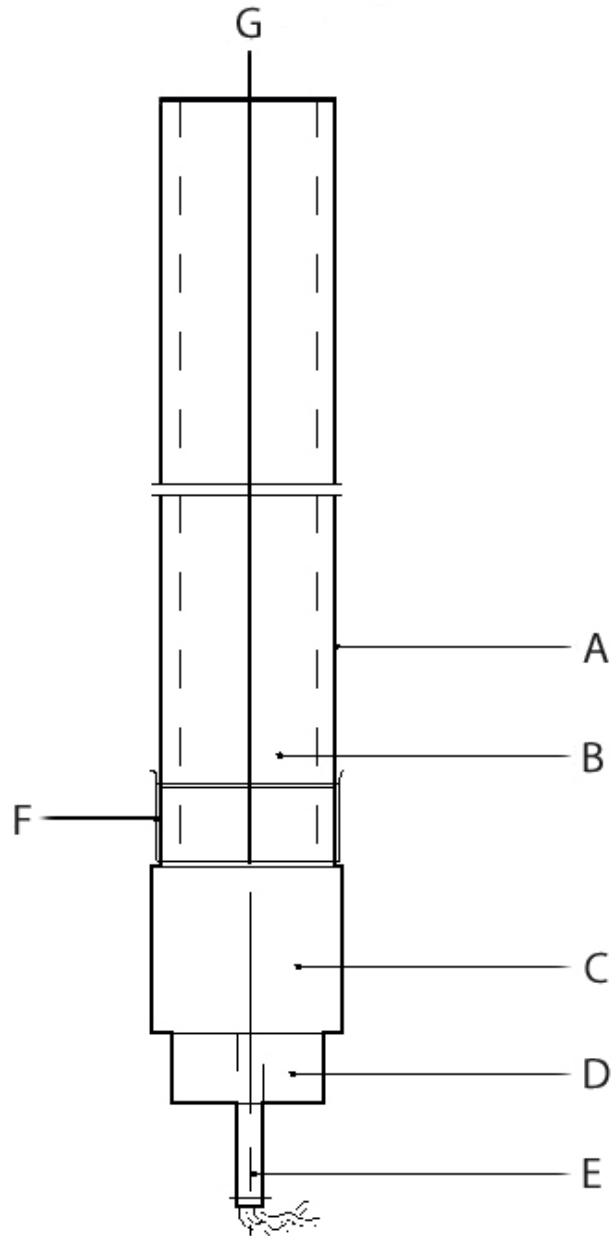

| | | | |
|----------------|------------------------------------|----------------|--------------------------|
| (A) | Spacers | (B) | Witness plate |
| (C) | Steel tube | (D) | Substance under test |
| (E) | RDX/wax or PETN/TNT booster charge | (F) | Detonator holder |
| (G) | Detonator | (H) | Plastics sheet |
| (I) | Velocity probe <u>(optional)</u> | | |

Figure 21.4.4.1: UN DETONATION TEST

SECTION 23

TEST SERIES C

23.1 Introduction

Test series C comprises laboratory tests and criteria concerning propagation of deflagration as requested in boxes 3, 4 and 5 of Figure 20.1.

23.2 Test methods

23.2.1 The question "Can it propagate a deflagration?" (boxes 3, 4 and 5 of Figure 20.1) is answered on the basis of the results of one, or if necessary both, of the test methods in Table 23.1.

Table 23.1: TEST METHODS FOR TEST SERIES C

| Test code | Name of test | Section |
|-----------|---------------------------------|---------|
| C.1 | Time/pressure test ^a | 23.4.1 |
| C.2 | Deflagration test ^a | 23.4.2 |

^a *Recommended test.*

23.2.2 The answer is "Yes, rapidly" if shown to be so by either test. The answer is "Yes, slowly" if the deflagration test result is "Yes, slowly" and the time/pressure test result is not "Yes, rapidly". The answer is "No" if the deflagration test result is "No" and the time/pressure test is not "Yes, rapidly".

23.3 Test conditions

23.3.1 *The preliminary procedure (see section 20.3) should be carried out before performing these tests.*

23.4 Series C test prescriptions**23.4.1 Test C.1: Time/pressure test**23.4.1.1 *Introduction*

This test is used to measure the ability of a substance¹ under confinement to propagate a deflagration. It may be used to answer the question in boxes 3, 4 and 5 of Figure 20.1.

23.4.1.2 *Apparatus and materials*

23.4.1.2.1 The time/pressure apparatus (Figure 23.4.1.1) consists of a cylindrical steel pressure vessel 89 mm in length and 60 mm in external diameter. Two flats are machined on opposite sides (reducing the cross-section of the vessel to 50 mm) to facilitate holding whilst fitting the firing plug and vent plug. The vessel, which has a bore of 20 mm diameter, is internally rebated at either end to a depth of 19 mm and threaded to accept 1" British Standard Pipe (BSP). A pressure take-off, in the form of a side-arm, is screwed into the curved face of the pressure vessel 35 mm from one end and at 90° to the machined flats. The socket for this is bored to a depth of 12 mm and threaded to accept the 1/2" BSP thread on the end of the side-arm. A washer is fitted to ensure a gas-tight seal. The side-arm extends 59 mm beyond the pressure vessel body and has a bore of 6 mm. The end of the side-arm is rebated and threaded to accept a diaphragm type pressure transducer. Any pressure-measuring device may be used provided that it is not affected by the hot gases or decomposition products and is capable of responding to rates of pressure rise of 690 to 2 070 kPa in not more than 5 ms.

23.4.1.2.2 The end of the pressure vessel furthest from the side-arm is closed with a firing plug which is fitted with two electrodes, one insulated from and the other earthed to the plug body. The other end of the pressure vessel is closed by an aluminium bursting disc 0.2 mm thick (bursting pressure approximately 2 200 kPa) held in place with a retaining plug which has a 20 mm bore. A deformable washer or rubber ring is used with both plugs to ensure a good seal. A support stand (Figure 23.4.1.2) holds the assembly in the correct attitude during use. This comprises a mild steel base plate measuring 235 mm × 184 mm × 6 mm and a 185 mm length of square hollow section (S.H.S.) 70 × 70 × 4 mm.

23.4.1.2.3 A section is cut from each of two opposite sides at one end of the length of S.H.S. so that a structure having two flat sided legs surmounted by an 86 mm length of intact box section results. The ends of these flat sides are cut at an angle of 60° to the horizontal and welded to the base plate.

23.4.1.2.4 A slot measuring 22 mm wide × 46 mm deep is machined in one side of the upper end of the base section such that when the pressure vessel assembly is lowered, firing plug end first, into the box section support, the side-arm is accommodated in this slot. A packing piece of steel 30 mm wide and 6 mm thick is welded to the lower internal face of the box section to act as a spacer. Two 7 mm thumb screws, tapped into the opposite face, serve to hold the pressure vessel firmly in place. Two 12 mm wide strips of 6 mm thick steel, welded to the side pieces abutting the base of the box section, support the pressure vessel from beneath.

23.4.1.2.5 The ignition system consists of an electric fusehead of the type commonly used in low tension detonators, or an insulated resistance wire, together with a 13 mm square piece of primed cambric. Fuseheads with equivalent properties may be used. Primed cambric consists of a linen fabric coated on both sides with a potassium nitrate/silicon/sulphurless gunpowder pyrotechnic composition².

23.4.1.2.6 The procedure for the preparation of the ignition assembly for solids starts with separation of the brass foil contacts of an electric fusehead from its insulator, (see Figure 23.4.1.3). The exposed portion of insulation is then cut off. The fusehead is then fixed onto the terminals of the firing plug by means of the brass contacts such that the tip of the fusehead is 13 mm above the surface of the firing plug. An approximately 13 mm square piece of primed cambric is pierced through the centre and positioned over the

¹ When testing liquids, variable results may be obtained because the substance may give two pressure peaks.

² Obtainable from the national contact for test details in United Kingdom (see Appendix 4).

attached fusehead around which it is then folded and secured with fine cotton thread. Alternatively, an insulated resistance wire can be used instead of a fusehead. The insulation is removed from the middle of the wire and the primed cambric is folded around the exposed resistance wire. The assembly is then fixed onto the terminals of the firing plug in the same way as mentioned for the fusehead.

23.4.1.2.7 For liquids samples, a single piece of thin PVC sheathing, or equivalent, is used to cover the primed cambric in such a way that the primed cambric is not in contact with the liquid sample. The leads of the resistance wire are then fixed onto the terminals of the firing plug such that the tip of the primed cambric is above the surface of the firing plug.

23.4.1.3 Procedure

23.4.1.3.1 The apparatus assembled, complete with pressure transducer but without the aluminium bursting disc in position, is supported firing plug end down. 5.0 g³ of the substance is introduced into the apparatus so as to be in contact with the ignition system. Normally no tamping is carried out when filling the apparatus unless it is necessary to use light tamping in order to get the 5.0 g charge into the vessel. If, even with light tamping, it is impossible to get all the 5.0 g of sample in, then the charge is fired after filling the vessel to capacity. Note should be taken of the charge weight used. The washer or rubber ring and aluminium bursting disc are placed in position and the retaining plug is screwed in tightly. The charged vessel is transferred to the firing support stand, bursting disc uppermost, which should be contained in a suitable, armoured fume cupboard or firing cell. A power source is connected to the external terminals of the firing plug and the charge is fired. The signal produced by the pressure transducer is recorded on a suitable data acquisition system which allows both evaluation and a permanent record of the time/pressure profile to be achieved.

23.4.1.3.2 The test is carried out three times. The time taken for the pressure to rise from 690 kPa to 2 070 kPa above atmospheric is noted. The shortest time interval should be used for classification.

23.4.1.4 Test criteria and method of assessing results

23.4.1.4.1 The test results are interpreted in terms of whether a gauge pressure of 2 070 kPa is reached and, if so, the time taken for the pressure to rise from 690 kPa to 2 070 kPa gauge.

23.4.1.4.2 The test criteria are as follows:

"Yes, rapidly": - The time for a pressure rise from 690 kPa to 2 070 kPa is less than 30 ms.

"Yes, slowly": - The time for a pressure rise from 690 kPa to 2 070 kPa is greater than or equal to 30 ms.

"No": - A pressure rise to 2 070 kPa above atmospheric is not achieved.

NOTE: *If necessary, the deflagration test, Test C.2, should be performed to distinguish between "Yes, slowly" and "No".*

³ *If preliminary safety-in-handling tests (e.g. heating in a flame) or burning tests (e.g. a series 3 type (d) test) indicate that a rapid reaction is likely to occur, then the sample size should be reduced to 0.5 g until the severity of the confined reaction is known. If it is necessary to use a 0.5 g sample size, the sample size is gradually increased until either a "Yes, rapidly" result is obtained or the test is performed with a 5.0 g sample.*

| Substance | Maximum pressure (kPa) | Time for a pressure rise from 690 to 2 070 kPa (ms) | Result |
|---|-------------------------------|--|---------------|
| Azodicarbonamide | > 2 070 | 63 | Yes, slowly |
| Azodicarbonamide, 67% with zinc oxide | > 2 070 | 21 | Yes, rapidly |
| 2,2'-Azodi(isobutyronitrile) | > 2 070 | 68 | Yes, slowly |
| 2,2'-Azodi(2-methylbutyronitrile) | > 2 070 | 384 | Yes, slowly |
| tert-Butyl hydroperoxide, 70% with water | 1 380 | - | No |
| tert-Butyl peroxybenzoate | > 2 070 | 2 500 | Yes, slowly |
| tert-Butyl peroxy-2-ethylhexanoate | > 2 070 | 4 000 | Yes, slowly |
| Cumyl hydroperoxide, 80% with cumene | < 690 ^a | - | No |
| 2-Diazo-1-naphthol-5-sulphohydrazide | > 2 070 | 14 | Yes, rapidly |
| Dibenzoyl peroxide | > 2 070 | 1 | Yes, rapidly |
| Di-tert-butyl peroxide | > 2 070 | 100 | Yes, slowly |
| Dicetyl peroxydicarbonate | < 690 | - | No |
| Dicumyl peroxide | < 690 ^a | - | No |
| Dicumyl peroxide, with 60% inert solid | < 690 ^a | - | No |
| 2,5-Diethoxy-4-morpholinobenzene-diazonium tetrafluoroborate, 97% | > 2 070 | 308 | Yes, slowly |
| Dilauroyl peroxide | 990 | - | No |
| 2,5-Dimethyl-2,5-di-(tert-butylperoxy)-hexyne-3 | > 2 070 | 70 | Yes, slowly |
| Magnesium monoperoxyphthalate hexahydrate, 85% with magnesium phthalate | 900 | - | No |
| 4-Nitrosophenol | > 2 070 | 498 | Yes, slowly |

^a *No ignition.*

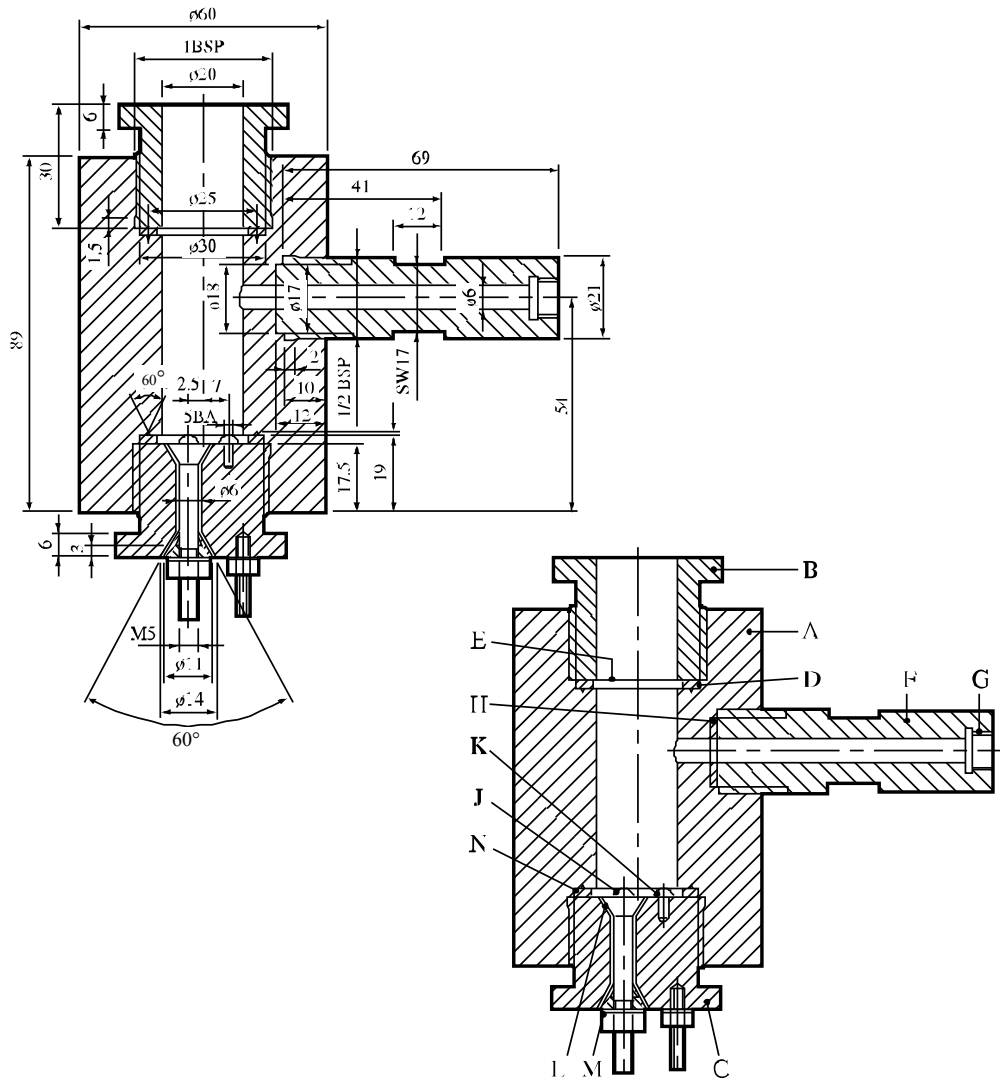

- | | | | |
|-----|----------------------------|-----|------------------------------|
| (A) | Pressure vessel body | (B) | Bursting disc retaining plug |
| (C) | Firing plug | (D) | Soft lead washer |
| (E) | Bursting disc | (F) | Side arm |
| (G) | Pressure transducer thread | (H) | Washer |
| (J) | Insulated Electrode | (K) | Earthed electrode |
| (L) | Insulation | (M) | Steel cone |
| (N) | Washer distorting groove | | |

Figure 23.4.1.1: APPARATUS

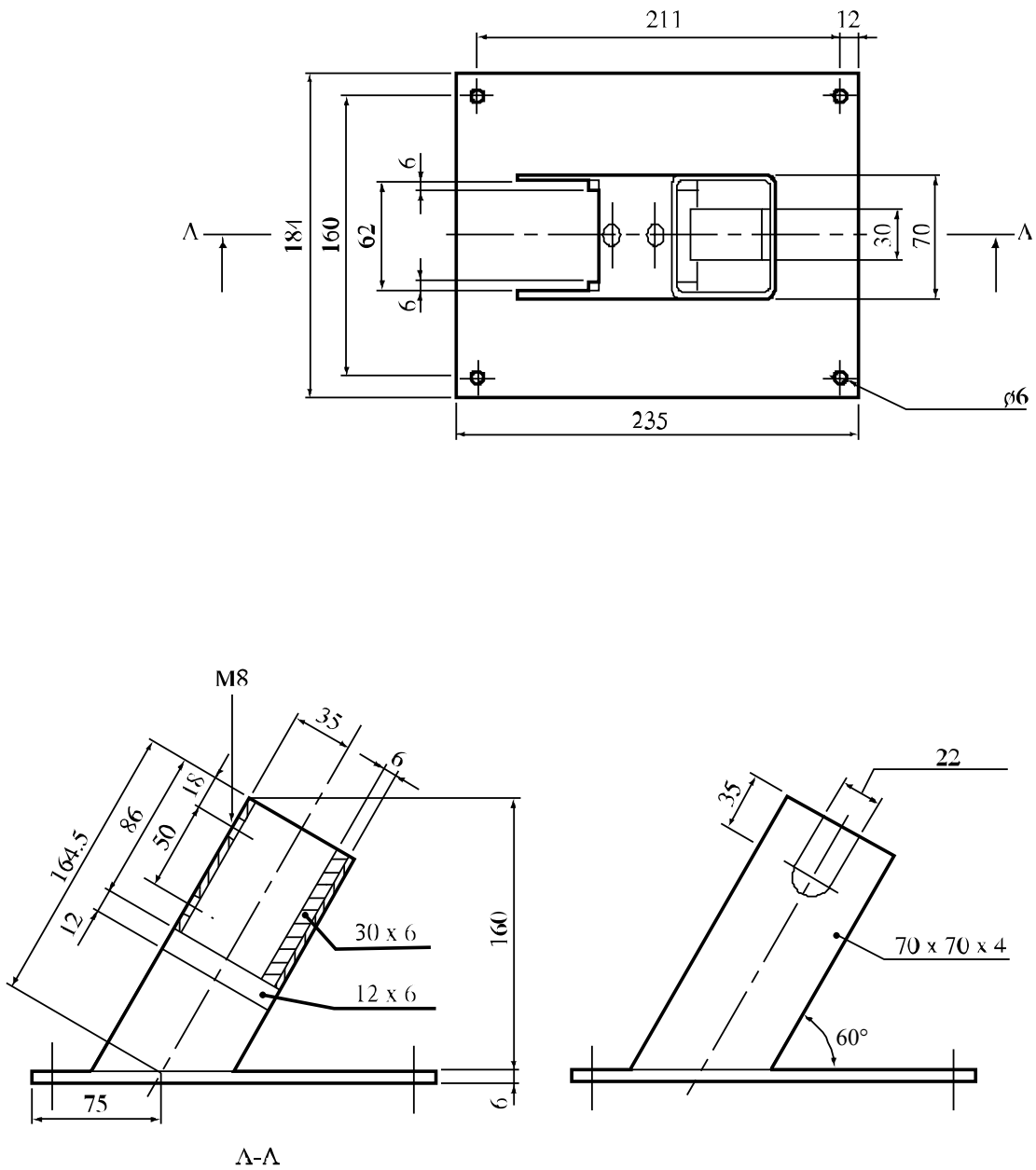
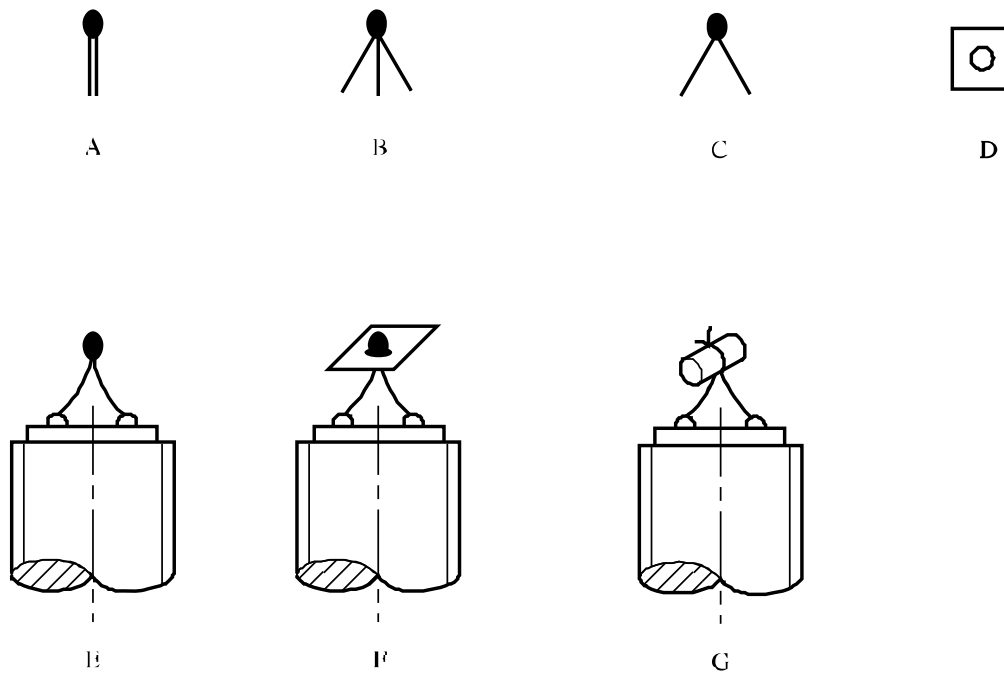
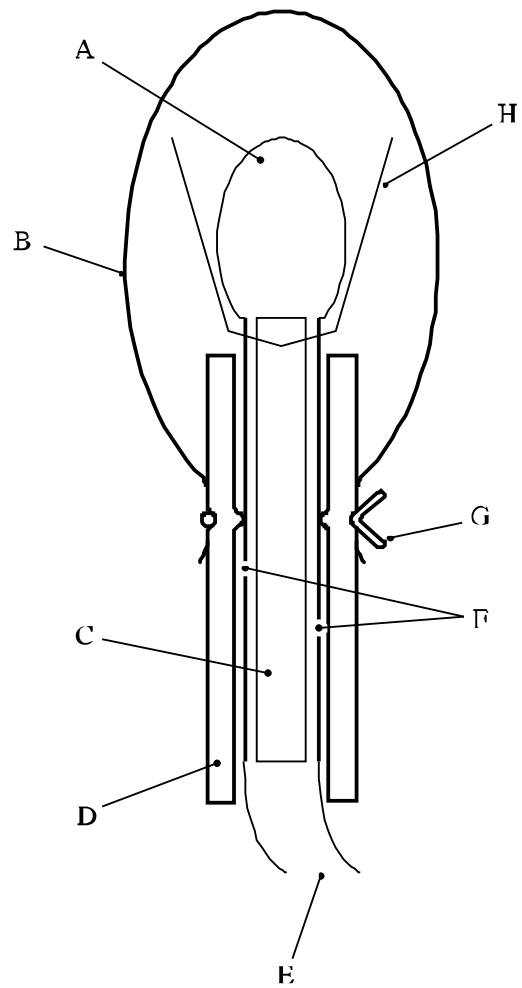

Figure 23.4.1.2: SUPPORT STAND



-
- (A) Electrically ignited fusehead as manufactured
 (B) Brass foil contacts parted from card insulator
 (C) Insulating card cut off
 (D) Primed cambric SR252 13 mm square with centre hole
 (E) Fusehead fixed to pins on firing plug
 (F) Cambric positioned on fusehead
 (G) Cambric folded around and tied with thread
-

Figure 23.4.1.3: IGNITION SYSTEM FOR SOLIDS



-
- | | |
|-----|--------------------------------|
| (A) | Fusehead |
| (B) | PVC sheath |
| (C) | Insulating card |
| (D) | Silicone rubber tubing |
| (E) | Firing leads |
| (F) | Foil contacts |
| (G) | Wire to make liquid-tight seal |
| (H) | Primed cambric |
-

Figure 23.4.1.4: IGNITION SYSTEM FOR LIQUIDS

23.4.2 *Test C.2: Deflagration test*

23.4.2.1 *Introduction*

This test is used to measure the ability of a substance to propagate a deflagration. It may be used to answer the question in boxes 3, 4 and 5 of Figure 20.1.

23.4.2.2 *Apparatus and materials*

23.4.2.2.1 The test is performed with a Dewar vessel (see Figure 23.4.2.1) which is provided with vertical observation windows on opposite sides. The windows are not necessary when using thermocouples to measure the deflagration rate. A timer with an accuracy of 1 second is used to measure the deflagration rate.

23.4.2.2.2 The Dewar vessel has a volume of about 300 cm³, an internal diameter of 48 ± 1 mm, an external diameter of 60 mm and a length between 180 and 200 mm. The half-time of cooling with water or other suitable material filled to a height of 20 mm below the rim (i.e. 265 cm³) of the Dewar vessel, closed by a tight fitting cork, should be longer than 5 hours. Horizontal graduation marks are drawn at 50 and 100 mm from the top of the Dewar vessel. The time it takes for the decomposition front to propagate from the 50 mm mark to the 100 mm mark yields the deflagration rate. A glass thermometer with an accuracy of 0.1 °C is used to measure the temperature of the test substance prior to ignition. Alternatively, the deflagration rate and sample temperature may be determined by using two thermocouples at distances of 50 mm and 100 mm from the top of the Dewar vessel.

23.4.2.2.3 Any gas flame with a flame length of at least 20 mm can be used for igniting the substance.

23.4.2.2.4 ***For personal protection, the test is performed in an explosion-proof fume-chamber or in a well-ventilated test-cell. The capacity of the exhaust fan shall be large enough to dilute the decomposition products to the extent that no explosive mixtures with air can be obtained. A shield is placed between the observer and the Dewar vessel.***

23.4.2.3 *Procedure*

23.4.2.3.1 ***If preliminary safety-in-handling tests (e.g. heating in a flame) or a small scale burning test (e.g. the series 3 type (d) test) indicate that a rapid reaction is likely to occur, exploratory tests in borosilicate glass tubes should be performed, with suitable safety precautions, prior to the Dewar vessel test.*** In this case, it is recommended that the test be performed in a 14 mm diameter tube first and subsequently in a 28 mm diameter tube. If the deflagration rate in any of these exploratory tests exceeds 5 mm/s, the substance can forthwith be classified as a rapidly deflagrating substance and the main test, using a Dewar vessel, can be omitted.

23.4.2.3.2 The Dewar vessel and the substance are brought to the emergency temperature as defined in the Model Regulations. If the substance is sufficiently stable as to require no emergency temperature, a test temperature of 50 °C is used. The Dewar vessel is filled to a height of 20 mm below the rim with the substance. Granular substances are filled into the Dewar vessel in such a way that the bulk density of the substance will be comparable with that in transport and there are no lumps.

23.4.2.3.3 Pasty materials are introduced into the Dewar vessel in such a way that no air pockets will be present in the sample to be tested. The height of filling shall be about 20 mm below the rim of the Dewar vessel. The mass and the temperature of the substance are recorded. The Dewar vessel is placed in the test-cell or fume-chamber behind a shield, after which the substance is heated at the top by means of a gas burner. At the moment when ignition is observed or, alternatively, if no ignition occurs within five minutes, the gas burner is removed and extinguished. The period of time that is required for the reaction zone to pass the distance between the two marks is measured with the timer. If the reaction stops before reaching the lower mark, the substance is considered to be non-deflagrative. The test is performed in duplicate and the shortest time interval is used for the calculation of the deflagration rate. Alternatively, the rate may be determined by locating thermocouples down the centre of the Dewar at distances 50 mm and 100 mm from

the top of the Dewar vessel. The thermocouple outputs are monitored continuously. The passage of the reaction front causes a steep increase in output. The time between the increases in output is determined.

23.4.2.4 *Test criteria and method of assessing results*

23.4.2.4.1 The test results are interpreted in terms of whether a reaction zone will propagate downwards through the substance and, if so, the rate of propagation. The participation of oxygen from the air in the reaction at the sample surface is negligible after the reaction zone has propagated over a distance of 30 mm. The reaction zone will extinguish if the substance does not deflagrate under the test conditions. The propagation velocity of the reaction zone (deflagration rate) is a measure of the susceptibility of the substance to deflagration under atmospheric pressure.

23.4.2.4.2 The test criteria are as follows:

- "Yes, rapidly": - the deflagration rate is greater than 5.0 mm/s.
- "Yes, slowly": - the deflagration rate is less than or equal to 5.0 mm/s and greater than or equal to 0.35 mm/s.
- "No": - the deflagration rate is less than 0.35 mm/s or the reaction stops before reaching the lower mark.

NOTE: *The time/pressure test, test C.1, is carried out if "Yes, rapidly" is not obtained.*

23.4.2.5 *Examples of results*

| Substance | Sample mass (g) | Temperature (°C) | Propagation rate (mm/s) | Result |
|--|------------------------|-------------------------|--------------------------------|---------------|
| Azodicarbonamide | 174 | 50 | 0.35 | Yes, slowly |
| 2,2'-Azodi(isobutyronitrile) | 101 | 45 | ^a | No |
| tert-Butyl peroxybenzoate | 276 | 50 | 0.65 | Yes, slowly |
| tert-Butyl peroxy-2-ethylhexanoate | 237 | 25 | 0.74 | Yes, slowly |
| tert-Butyl peroxy-3,5,5-trimethylhexanoate, 75% in solvent | 238 | 50 | 0.27 | No |
| Cumyl hydroperoxide, 80% with cumene | 273 | 50 | 0.12 | No |
| Dibenzoyl peroxide | 158 | 20 | 100 ^b | Yes, rapidly |
| Di-tert-butyl peroxide | 212 | 50 | 0.27 | No |
| Di-(4-tert-butylcyclohexyl) peroxydicarbonate | 123 | 35 | 4.3 | Yes, slowly |
| Dicetyl peroxydicarbonate | 159 | 35 | No ignition | No |
| Dicumyl peroxide | 292 | 50 | No ignition | No |
| Dicyclohexyl peroxydicarbonate | - | 26 | 26 | Yes, rapidly |
| Dicyclohexyl peroxydicarbonate, 90% with water | - | 15 | 13 | Yes, rapidly |
| Dilauroyl peroxide | 130 | 45 | No ignition | No |
| Dilauroyl peroxide, 42% stable dispersion in water | 265 | 45 | No ignition | No |
| 2,5-Dimethyl-2,5-di-(tert-butylperoxy)-hexyne-3 | 235 | 50 | 2.9 | Yes, slowly |
| 2,5-Dimethyl-2,5-di-(benzoylperoxy)-hexane | 231 | 50 | 6.9 | Yes, rapidly |
| 4-Nitrosophenol | 130 | 35 | 0.90 | Yes, slowly |

^a *Pulsating flame followed by extinguishing of flame; no stable propagation under test conditions.*

^b *Performed with an exploratory test using a glass tube with a diameter of 14 mm at 20 °C instead of 50 °C.*

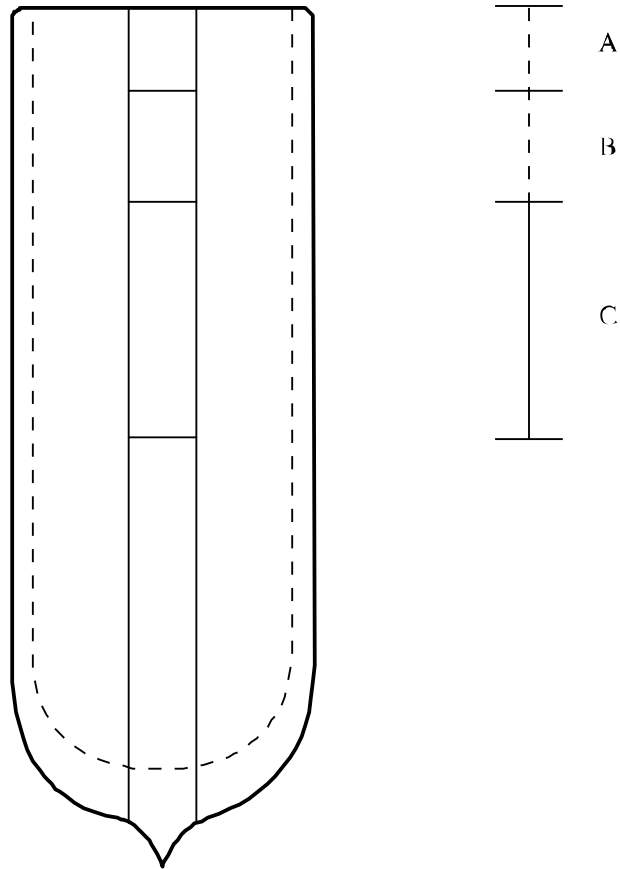

-
- (A) Height of filling 20 mm below rim
 - (B) 30 mm region for deflagration to be established
 - (C) 50 mm region for measuring the deflagration rate
-

Figure 23.4.2.1: DEWAR VESSEL WITH OBSERVATION WINDOWS

SECTION 25

TEST SERIES E

25.1 Introduction

25.1.1 Test series E comprises laboratory tests and criteria concerning the determination of the effect of heating under defined confinement as requested in boxes 7, 8, 9 and 13 of Figure 20.1.

25.2 Test methods

25.2.1 The question "What is the effect of heating it under defined confinement?" (boxes 7, 8, 9 and 13 of Figure 20.1) is answered on the basis of combinations of the results from the test methods in Table 25.1.

Table 25.1: TEST METHODS FOR TEST SERIES E

| Test code | Name of test | Section |
|-----------|---|---------|
| E.1 | Koenen test ^a | 25.4.1 |
| E.2 | Dutch pressure vessel test ^b | 25.4.2 |
| E.3 | USA pressure vessel test | 25.4.3 |

^a *Recommended test for self-reactive substances in combination with one of the other tests.*

^b *Recommended test for organic peroxides in combination with one of the other tests.*

25.2.2 The combination of the Koenen test and either the Dutch pressure vessel or USA pressure vessel test should be used for self-reactive substances. The combination of the Dutch pressure vessel test and either the Koenen test or the USA pressure vessel test should be used for organic peroxides. For classification, the highest hazard rating should be applied.

25.3 Test conditions

25.3.1 *The preliminary procedure (see section 20.3) should be carried out before performing these tests.*

25.4 Series E test prescriptions

25.4.1 Test E.1: Koenen test

25.4.1.1 Introduction

This test is used to determine the sensitiveness of substances to the effect of intense heat under high confinement. It may be used, in conjunction with an additional heating under confinement test, to answer the question in boxes 7, 8, 9 and 13 of Figure 20.1.

25.4.1.2 Apparatus and materials

25.4.1.2.1 The apparatus consists of a non-reusable steel tube, with its re-usable closing device, installed in a heating and protective device. The tube is deep drawn from sheet steel conforming to specification DC04 (EN 10027-1), or equivalent A620 (AISI/SAE/ASTM), or equivalent SPCCEN (JIS G 3141). (to be checked) The dimensions are given in Figure 25.4.1.1. The open end of the tube is flanged. The closing plate with an orifice, through which the gases from the decomposition of the test substance escape, is made from heat-resisting chrome steel. For classification the following diameter holes shall be used: 1.0 - 1.5 - 2.0 - 2.5 - 3.0 - 5.0 - 8.0 - 12.0 - 20.0 mm. In addition, other diameters can be used for hazard assessment. The dimensions of the threaded collar and the nut (closing device) are given in Figure 25.4.1.1.

For quality control of the steel tubes, 1% of the tubes from each production lot shall be subjected to quality control and the following data shall be verified:

- (a) The mass of the tubes shall be 26.5 ± 1.5 g (to be checked), tubes to be used in one test sequence shall not differ in mass by more than 1 g;
- (b) The length of the tubes shall be 75 ± 0.5 mm (to be checked);
- (c) The wall thickness of the tubes measured 20 mm from the bottom of the tube shall be 0.5 ± 0.05 mm (to be checked); and
- (d) The bursting pressure as determined by quasi-static load through an incompressible fluid shall be 30 ± 3 MPa (to be checked).

25.4.1.2.2 Heating is provided by propane, from an industrial cylinder fitted with pressure regulator, via a flow meter and distributed by a manifold to the four burners. Other fuel gases may be used provided the specified heating rate is obtained. The gas pressure is regulated to give a heating rate of 3.3 ± 0.3 K/s when measured by the calibration procedure. Calibration involves heating a tube (fitted with a 1.5 mm orifice plate) filled with 27 cm³ of dibutyl phthalate (to be replaced by other liquid). The time taken for the temperature of the liquid (measured with a 1 mm diameter thermocouple centrally placed 43 mm below the rim of the tube) to rise from 135 °C to 285 °C is recorded and the heating rate calculated.

25.4.1.2.3 Because the tube is likely to be destroyed in the test, heating is undertaken in a protective welded box, the construction and dimensions of which are given in Figure 25.4.1.2. The tube is suspended between two rods placed through holes drilled in opposite walls of the box. The arrangement of the burners is given in Figure 25.4.1.2. The burners are lit simultaneously by a pilot flame or an electrical ignition device. **The test apparatus is placed in a protected area.** Measures should be taken to ensure that the burner flames are not affected by any draughts. Provision should be made for extracting any gases or smoke resulting from the test.

25.4.1.3 Procedure

25.4.1.3.1 Normally substances are tested as received although in certain cases it may be necessary to test the substance after crushing it. For solids, the tube is filled according to the next procedure. Fill the tube to a level of maximally 45 mm from the top and tamp¹ the substance with 80 N force applied to the total cross-section of the tube. Then add one or two further increments with 80 N tamping and adjust the level of the substance in the tube adjusted to 15 mm from the top by addition or subtraction of material as required. Determine the total mass used to fill the tube to this level and use this amount of solid for each trial filling being performed in two or three increments, each compressed by whatever force is necessary. (This may be facilitated by the use of spacing rings.) Liquids and gels are loaded into the tube to a height of 60 mm taking particular care with gels to prevent the formation of voids. The threaded collar is slipped onto the tube from below, the appropriate orifice plate is inserted and the nut tightened by hand after applying some molybdenum disulphide based lubricant. It is essential to check that none of the substance is trapped between the flange and the plate, or in the threads.

25.4.1.3.2 With orifice plates from 1.0 mm to 8.0 mm diameter, nuts with an orifice of 10.0 mm diameter should be used; if the diameter of the orifice is above 8.0 mm, that of the nut should be 20.0 mm. Each tube is used for one trial only. The orifice plates, threaded collars and nuts may be used again provided they are undamaged.

25.4.1.3.3 The tube is placed in a rigidly mounted vice and the nut tightened with a spanner. The tube is then suspended between the two rods in the protective box. The test area is vacated, the gas supply turned on and the burners lit. The time to reaction and duration of reaction can provide additional information useful in interpreting the results. If rupture of the tube does not occur, heating is continued for at least five minutes before the trial is finished. After each trial the fragments of the tube, if any, should be collected and weighed.

25.4.1.3.4 The following effects are differentiated:

- "O": Tube unchanged;
- "A": Bottom of tube bulged out;
- "B": Bottom and wall of the tube bulged out;
- "C": Bottom of tube split;
- "D": Wall of tube split;
- "E": Tube split into two² fragments;
- "F": Tube fragmented into three² or more mainly large pieces which in some cases may be connected with each other by a narrow strip;
- "G": Tube fragmented into many mainly small pieces, closing device undamaged; and
- "H": Tube fragmented into many very small pieces, closing device bulged out or fragmented.

Examples for the effect types "D", "E" and "F" are shown in Figure 25.4.1.3. If a trial results in any of the effects "O" to "E", the result is regarded as "no explosion". If a trial gives the effect "F", "G" or "H", the result is evaluated as "explosion".

25.4.1.3.5 The series of trials is started with a single trial using an orifice plate with a certain diameter. If, in this trial, the result "explosion" is observed, the series is continued with single trials at increasing diameters until only negative results in three tests are obtained at the same level. If in the first trial "no explosion" occurs, the series is continued with single trials using plates with the decreasing diameters and finally 1.0 mm until, at one of these diameters, the result "explosion" is obtained. Subsequently, trials are carried out at increasing diameters until only negative results in three tests are obtained at the same diameter. The limiting diameter of a substance is the largest diameter of the orifice at which the result "explosion" is

¹ **For reasons of safety, e.g. the substance is impact and/or friction sensitive, the substance need not be tamped.** In cases where the physical form of the sample can be changed by compression or compression of the sample is not related to the transport conditions, e.g. for fibrous materials, more representative filling procedures may be used.

² The upper part of the tube remained in the closing device is counted as one fragment.

obtained. If no "explosion" is obtained with a diameter of 1.0 mm, the limiting diameter is recorded as being less than 1.0 mm.

25.4.1.4 *Test criteria and method of assessing results*

25.4.1.4.1 The test criteria are as follows:

- "Violent": - The limiting diameter is greater than or equal to 2.0 mm.
- "Medium": - The limiting diameter is equal to 1.5 mm.
- "Low": - The limiting diameter is equal to or less than 1.0 mm and the effect in any test is different from type "O".
- "No": - The limiting diameter is less than 1.0 mm and the effect in all tests is of type "O".

25.4.1.5 *Examples of results*

| Substance | Sample mass (g) | Limiting diameter (mm) | Type of fragmentation ^a | Result |
|--|-----------------|------------------------|------------------------------------|---------|
| Azodicarbonamide | 20.0 | 1.5 | "F" | Medium |
| Azodicarbonamide, 67% with zinc oxide | 24.0 | 1.5 | "F" | Medium |
| 2,2'-Azodi(2,4-dimethylvaleronitrile) | 17.5 | < 1.0 | "O" | No |
| 2,2'-Azodi(isobutyronitrile) | 15.0 | 3.0 | "F" | Violent |
| Benzene-1,3-disulphohydrazide | | 12.0 | "F" | Violent |
| Benzene-1,3-disulphohydrazide, 70% with mineral oil | | 2.0 | "F" | Violent |
| Benzene sulphohydrazide | 18.5 | 1.0 | "F" | Low |
| tert-Butyl peroxybenzoate | 26.0 | 3.5 | "F" | Violent |
| tert-Butyl peroxy-2-ethylhexanoate | 24.2 | 2.0 | "F" | Violent |
| Cumyl hydroperoxide, 84.1% in cumene | 27.5 | 1.0 | "F" | Low |
| 2-Diazo-1-naphthol-5-sulphochloride | 19.0 | 2.5 | "F" | Violent |
| Dibenzoyl peroxide | 17.5 | 10.0 | "F" | Violent |
| Dibenzoyl peroxide, 75% with water | 20.0 | 2.5 | "F" | Violent |
| Di-tert-butyl peroxide, | 21.5 | <1.0 | "O" | No |
| Dicetyl peroxydicarbonate | 16.0 | <1.0 | "O" | No |
| 2,4-Dichlorobenzoyl peroxide | 21.0 | 6.0 ^b | "F" | Violent |
| Dicumyl peroxide | 18.0 | <1.0 | "O" | No |
| Diisopropyl peroxydicarbonate | 21.0 | 8.0 | "F" | Violent |
| Dilauroyl peroxide | 14.0 | <1.0 | "O" | No |
| 2,5-Dimethyl-2,5-di(tert-butylperoxy)-hexane | 23.0 | 1.5 | "F" | Medium |
| Dimyristyl peroxydicarbonate | 16.0 | <1.0 | "O" | No |
| N,N'-Dinitroso-N,N'-dimethyl-terephthalamide 70%, with mineral oil | 18.0 | 4.0 | "F" | Violent |
| Diperoxy isophthalic acid | 18.0 | 24.0 | "H" | Violent |
| Disuccinic acid peroxide | 18.0 | 6.0 | "F" | Violent |
| 4-Nitrosophenol | 17.0 | < 1.0 | "A" | Low |

^a *At the limiting diameter.*

^b *With a sample mass of 13 g the limiting diameter is < 1.0 mm*

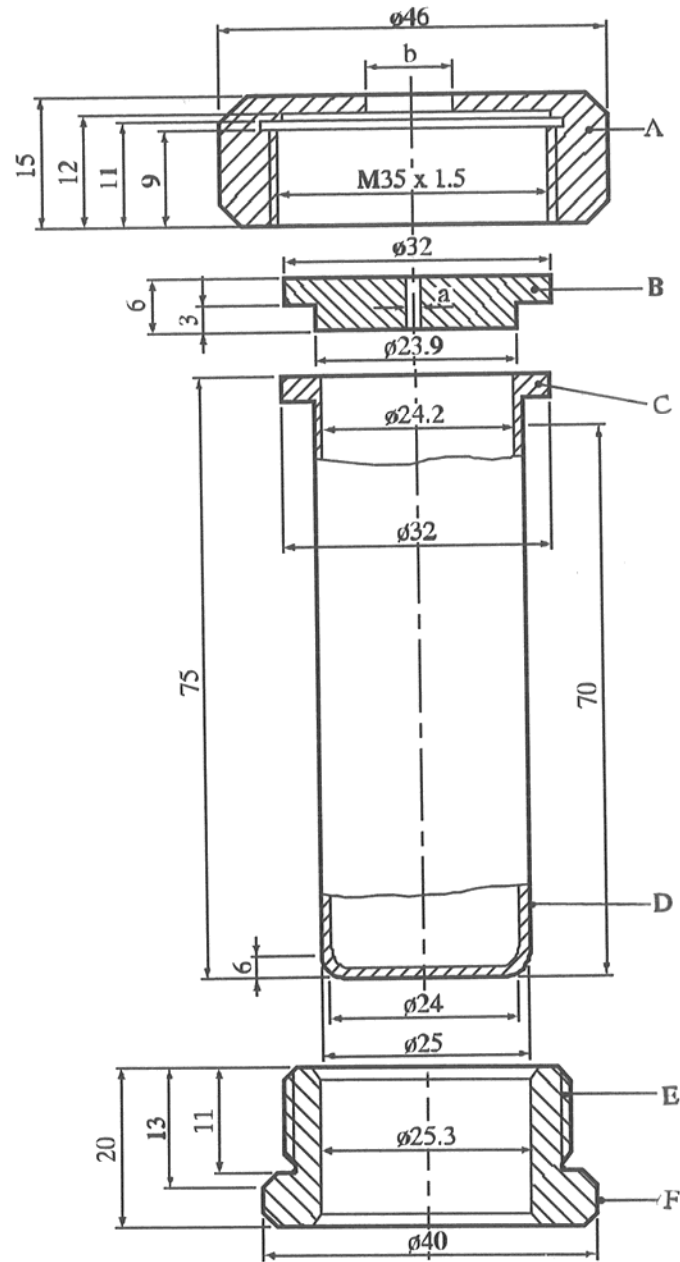

- (A) Nut ($b = 10.0$ or 20.0 mm) with flats for size 41 spanner
 (B) Orifice plate ($a = 1.0$ to 20.0 mm diameter)
 (C) Flange Threaded collar
 (D) Tube Flats for size 36 spanner
 (E) Threaded collar Flange
 (F) Flats for size 36 spanner Tube

Figure 25.4.1.1: TEST TUBE ASSEMBLY

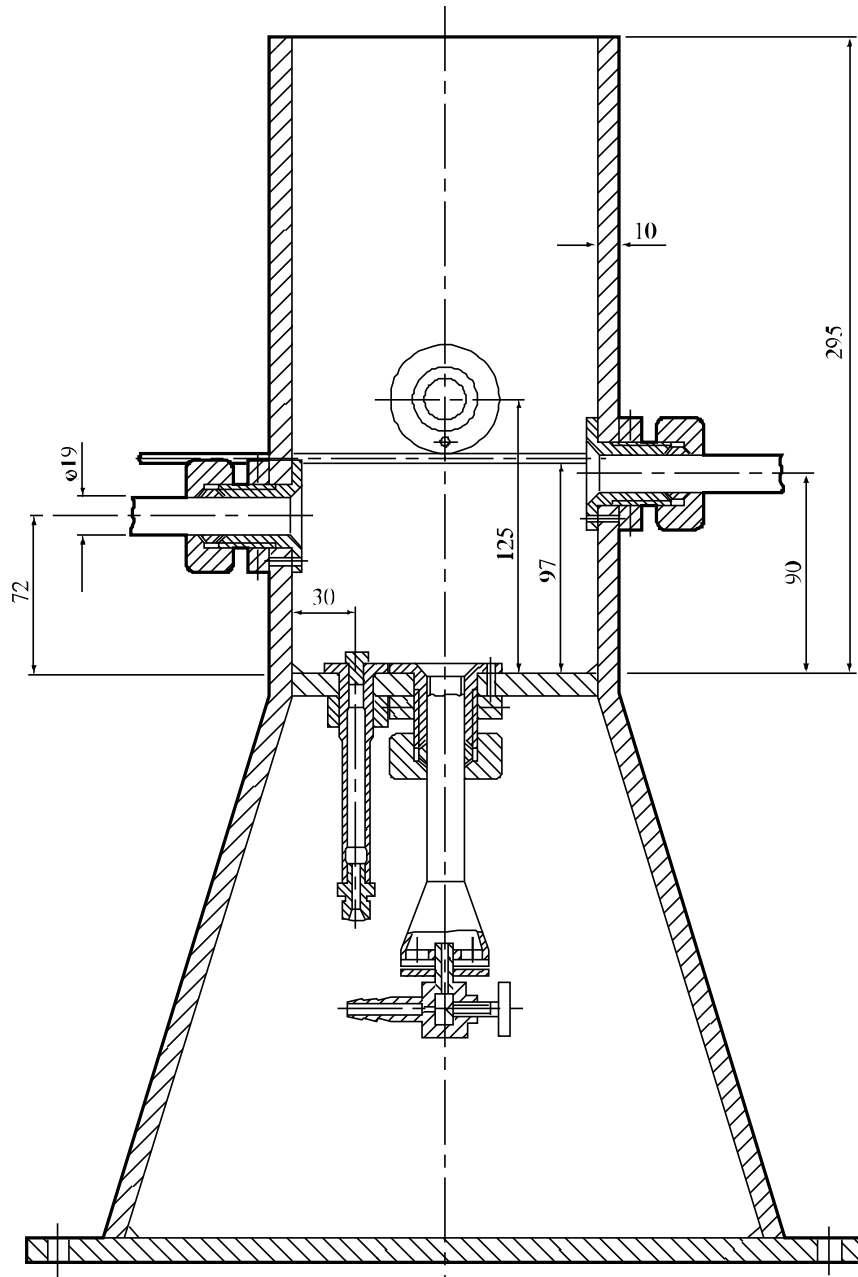

Figure 25.4.1.2: HEATING AND PROTECTIVE DEVICE

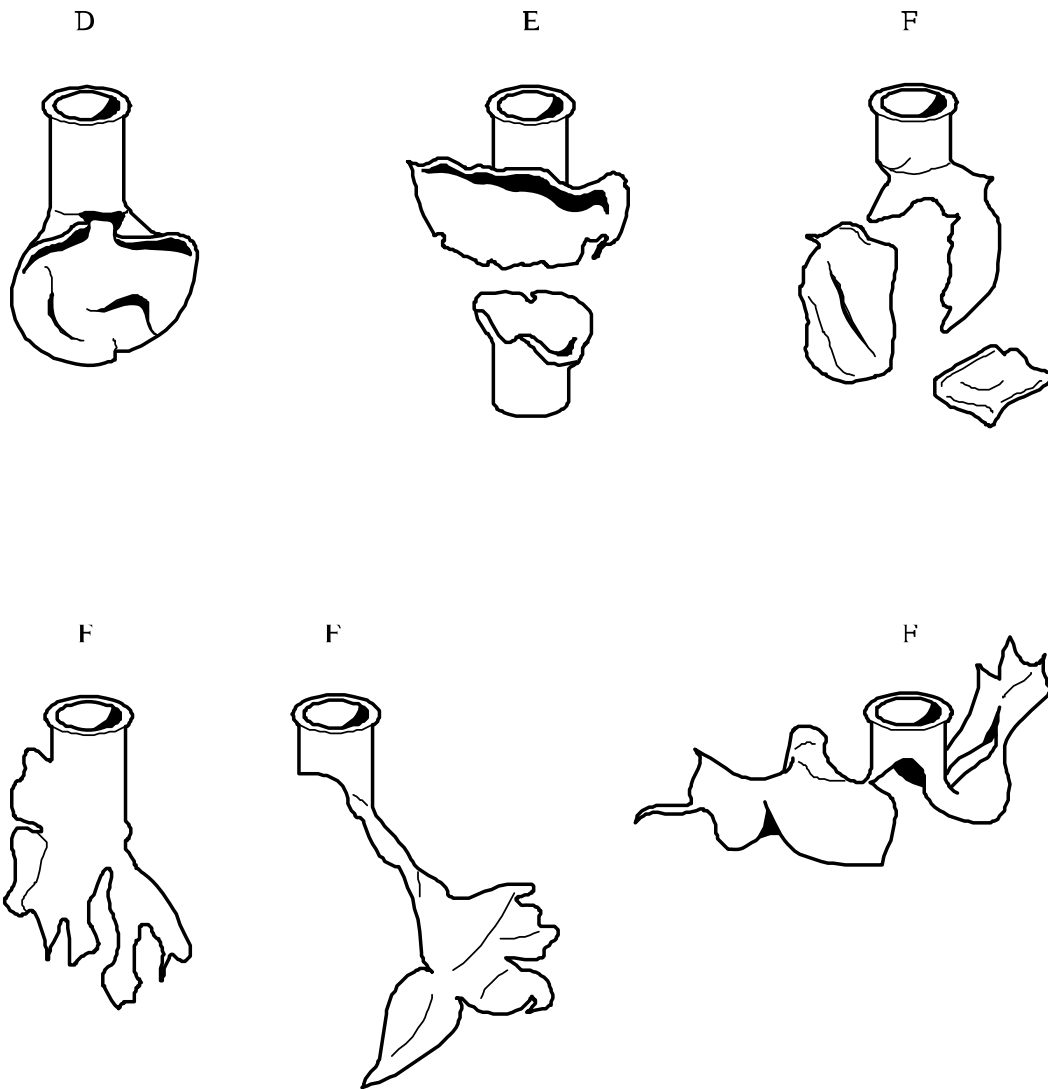

Figure 25.4.1.3: EXAMPLES OF EFFECT TYPES D, E AND F

25.4.2 *Test E.2: Dutch pressure vessel test*

25.4.2.1 *Introduction*

This test is used to determine the sensitiveness of substances to the effect of intense heat under defined confinement. It may be used, in conjunction with an additional heating under confinement test, to answer the question in boxes 7, 8, 9 and 13 of Figure 20.1.

25.4.2.2 *Apparatus and materials*

25.4.2.2.1 Description of the pressure vessel

Figure 25.4.2.1 shows the apparatus used. The vessel is made of stainless steel, type AISI 316. 8 aperture discs are used, the diameters of the orifices being: 1.0 - 2.0 - 3.5 - 6.0 - 9.0 - 12.0 - 16.0 and 24.0 mm. In addition other diameters may be used for hazard assessment. These discs have a thickness of $2.0 \text{ mm} \pm 0.2 \text{ mm}$. The bursting discs are 38 mm diameter aluminium discs rated to burst at $620 \pm 60 \text{ kPa}$ at $22 \text{ }^\circ\text{C}$ (see Figure 25.4.2.2).

25.4.2.2.2 Heating device

The pressure vessel is heated by technical-grade butane taken from a cylinder fitted with a pressure regulator. A Teclu burner is used. Other gases may be used, with a suitable burner, provided that a heating rate of $3.5 \pm 0.3 \text{ K/s}$ is obtained. The heating rate should be checked by heating 10 g of dibutyl phthalate (to be replaced by other liquid) in the pressure vessel and measuring its temperature. The time taken for the temperature of the oil to rise from $50 \text{ }^\circ\text{C}$ to $200 \text{ }^\circ\text{C}$ is recorded and the heating rate calculated.

25.4.2.3 *Procedure*

25.4.2.3.1 For a normal test, 10.0 g of the substance should be placed in the vessel. The bottom of the vessel should be evenly covered with the substance. The bursting disc, the selected orifice plate and retaining ring are then put in place. The wing nuts are tightened by hand and the box nut with a spanner. The bursting disc is covered by enough water to keep it at a low temperature. The pressure vessel is placed on a tripod (with an inside ring diameter of 67 mm) which may be placed inside a protective cylinder. The ring at the middle of the vessel rests on the tripod.

25.4.2.3.2 The burner is lit, the flow of gas is set to the required rate and the flow of air adjusted so that the colour of the flame is blue and the inner cone of the flame light blue. The tripod should be of such a height that the inner cone just touches the bottom of the vessel. The burner is then placed under the vessel through an opening in the protective casing. ***The test area should be very well ventilated and entry prohibited during the test.*** The vessel is observed from outside the test area either by mirrors or by an aperture in the wall fitted with armoured glass. The time to reaction and duration of reaction can provide additional information useful in interpreting the results. Finally the receptacle is cooled in water and cleaned.

25.4.2.3.3 The series of trials is started with a single trial using an orifice plate with a certain diameter. If there is no rupture of the disc with this orifice, experiments are performed with single trial using plates with decreasing diameters until rupture of the disc occurs. In cases where no disc rupture is observed with an orifice of 1.0 mm, the next test with an orifice of 1.0 mm is carried out with 50.0 g of the substance instead of 10.0 g. If still no rupture of the disc is observed the experiment is repeated until three successive experiments without rupture are obtained. In the event of rupture of the disc, the experiments are repeated at the next higher level (10 g instead of 50 g or next higher diameter of the orifice) until the level is found at which there are no ruptures in three successive experiments.

25.4.2.4 *Test criteria and method of assessing results*

25.4.2.4.1 The relative degree of sensitivity of a substance to heating in a pressure vessel is expressed by the limiting diameter. This being the orifice with the largest diameter in millimetres with which, in three tests, the bursting disc is broken at least once, while having remained unbroken during three tests with the next larger diameter.

25.4.2.4.2 The test criteria are as follows:

- "Violent": - Rupture of the disc with an orifice of 9.0 mm or greater and a sample mass of 10.0 g.
- "Medium": - No rupture of the disc with an orifice of 9.0 mm but rupture of the disc with an orifice of 3.5 mm or larger but smaller than 9.0 mm and a sample mass of 10.0 g.
- "Low": - No rupture of the disc with an orifice of 3.5 mm and a sample mass of 10.0 g but rupture of the disc with an orifice of 1.0 mm or larger but smaller than 3.5 mm and a sample mass of 10.0 g or rupture of the disc with an orifice of 1.0 mm and a sample mass of 50.0 g.
- "No": - No rupture of the disc with an orifice of 1.0 mm and a sample mass of 50.0 g.

25.4.2.5 *Examples of results*

| Substance | Limiting diameter (mm) | Result |
|--|------------------------|---------|
| Azodicarbonamide | 1.5 | Low |
| 2,2'-Azodi-(2,4-dimethylvaleronitrile) | 6.0 | Medium |
| 2,2'-Azodi(isobutyronitrile) | 5.5 | Medium |
| 2,2'-Azodi(2-methylbutyronitrile) | 6.0 | Medium |
| tert-Butyl peroxybenzoate | 9.0 | Violent |
| tert-Butyl peroxy-2-ethylhexanoate | 6.0 | Medium |
| Cumyl hydroperoxide, 80% with cumene | 1.0 | Low |
| Dibenzoyl peroxide, 75% with water | 6.0 | Medium |
| Di-tert-butyl peroxide | 3.5 | Medium |
| Dicetyl peroxydicarbonate | 1.0 | Low |
| Dicumyl peroxide | 3.5 | Medium |
| 2,5-Diethoxy-4-morpholinobenzenediazonium zinc chloride, 90% | < 1.0 ^a | No |
| 2,5-Diethoxy-4-morpholinobenzenediazonium tetrafluoroborate, 97% | < 1.0 | No |
| 2,5-Diethoxy-4-(phenylsulphonyl)-benzenediazonium zinc chloride, 67% | < 1.0 ^a | No |
| Dilauroyl peroxide | 2.0 | Low |
| Dilauroyl peroxide, 42%, stable dispersion in water | < 1.0 ^a | No |
| 3-Methyl-4-(pyrrolidin-1-yl)benzenediazonium tetrafluoroborate, 95% | < 1.0 ^a | No |
| 4-Nitrosophenol | 1.0 ^a | Low |

^a Test carried out with a 50 g sample.

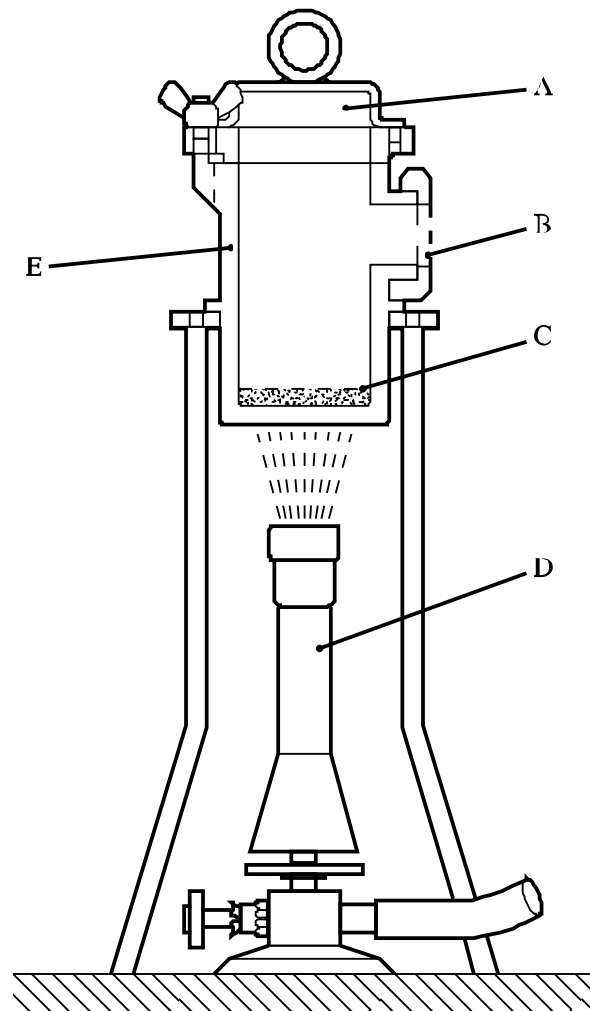

-
- (A) Bursting disc
 - (B) Orifice plate
 - (C) Test sample (10 g or 50 g)
 - (D) Teclu burner
 - (E) Pressure vessel with an internal diameter of 50 mm and internal height of 94.5 mm
-

Figure 25.4.2.1: DUTCH PRESSURE VESSEL TEST

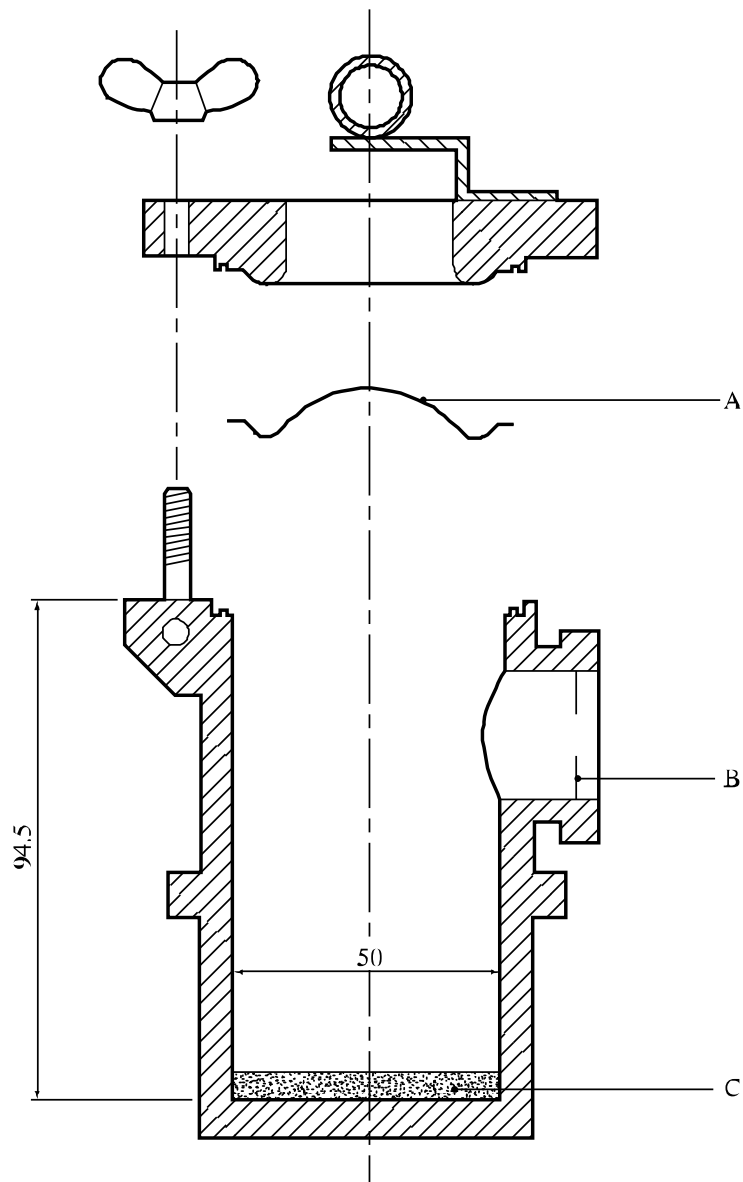

- (A) Bursting disc
- (B) Orifice plate
- (C) Test sample

Figure 25.4.2.2: BURSTING DISC ASSEMBLY

25.4.3 *Test E.3: United States pressure vessel test to be checked by regular users of this test.*

25.4.3.1 *Introduction*

This test is used to determine the sensitiveness of substances to the effect of intense heat under defined confinement. It may be used, in conjunction with an additional heating under confinement test, to answer the question in boxes 7, 8, 9 and 13 of Figure 20.1.

25.4.3.2 *Apparatus and materials*

The following apparatus and materials are used:

- (a) Test-vessel: 316 stainless steel cylindrical pressure vessel (see Figure 25.4.3.1);
- (b) Pressure vessel holder (see Figure 25.4.3.2);
- (c) Electrical heater (e.g. 700 W);
- (d) Sample holder: aluminium cup 28 mm × 30 mm;
- (e) Rupture discs: 38 mm aluminium rupture discs rated 620 ± 50 kPa at 22 °C;
- (f) 2 mm thick orifice plates with the following orifice diameters (mm): 1.0, 1.2, 2.0, 3.0, 3.5, 5.0, 6.0, 8.0, 9.0, 12.0, 16.0 and 24.0.

25.4.3.3 *Procedure*

25.4.3.3.1 The general assembly of the apparatus is shown in Figure 25.4.3.1. The heating rate should be checked by heating 5.0 g of dibutyl phthalate in a sample cup in the pressure vessel and measuring the temperature of the dibutyl phthalate. The time taken for the temperature of the dibutyl phthalate to rise from 50 °C to 200 °C is recorded and the heating rate calculated. The heating rate should be 0.5 ± 0.1 K/s. An orifice plate, with an orifice diameter larger than the expected vent needed to cause rupture, is selected and inserted into the side port.

25.4.3.3.2 A 5.0 g sample of the substance to be tested is weighed accurately into an aluminium cup. The cup is then lowered and positioned with the aid of forceps in the centre of the pressure vessel. The rupture disc is positioned and secured tightly by the flange bolts. Water is poured over the rupture disc to keep the disc relatively cool. The heating is switched on to the correct setting at least 30 minutes prior to the start of the test. The test-vessel is inserted into the pressure vessel holder onto the heater. This plate holder prevents the test-vessel from falling over. It also prevents escaping vent vapours from reaching the hot plate. The time to decomposition is noted.

25.4.3.3.3 If the disc does not rupture, the experiment is repeated using a smaller orifice diameter until rupture of the disc occurs. In the event of a rupture of the disc, the experiment is repeated at the next higher diameter of the orifice until the level is found at which there are no ruptures in three successive experiments.

25.4.3.4 *Test criteria and method of assessing results*

25.4.3.4.1 The smallest orifice diameter which does not cause a rupture disc to burst during decomposition is designated as the USA-PVT number. This value is used as a measure of the effects of heating a substance under defined confinement. USA-PVT ratings for all substances are based on the same test conditions and heating rate.

25.4.3.4.2 The effect of heating under confinement of the substance is defined by the following criteria:

"Violent": - Substances having USA-PVT numbers 9.0 to 24.0.

- "Medium": - Substances having USA-PVT numbers 3.5 to 8.0.
- "Low": - Substances having USA-PVT numbers 1.2 to 3.0.
- "No": - Substances having USA-PVT number 1.0.

25.4.3.5 *Examples of results*

| Substance | USA-PVT No | Result |
|--|-------------------|---------------|
| tert-Butyl hydroperoxide, 70% with water | 1.0 | No |
| tert-Butyl peroxy acetate, 75% in solution | 8.0 | Medium |
| tert-Butyl peroxybenzoate | 8.0 | Medium |
| tert-Butyl peroxy isopropyl carbonate, 75% in solution | 2.0 | Low |
| tert-Butyl peroxy pivalate, 75% in solution | 4.5 ^a | Medium |
| Cumyl hydroperoxide, 85% with cumene | 1.0 | No |
| Dibenzoyl peroxide | 18.0 ^a | Violent |
| Di-tert-butyl peroxide | 1.0 | No |
| Dicumyl peroxide | 2.0 | Low |
| Dicumyl peroxide, with 60% inert solid | 1.0 | No |
| Dilauroyl peroxide | 6.0 | Medium |
| 2,5-Dimethyl-2,5-di-(tert-butylperoxy) hexyne-3 | 9.0 | Violent |

^a *Intermediate diameters, no longer used.*

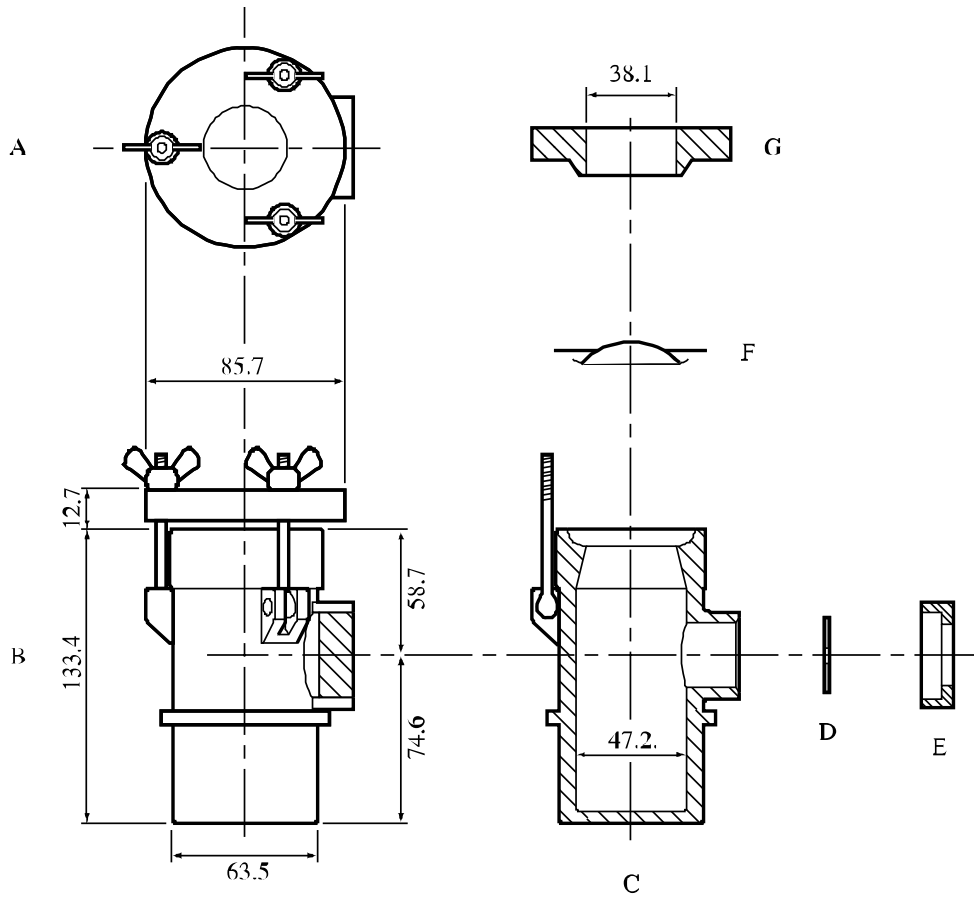

- (A) Top view of lid
- (B) Side view of assembly
- (C) Body of pressure vessel
- (D) Orifice plate
- (E) Orifice plate retaining nut
- (F) Bursting disc
- (G) Cap

Figure 25.4.3.1: UNITED STATES PRESSURE VESSEL TEST

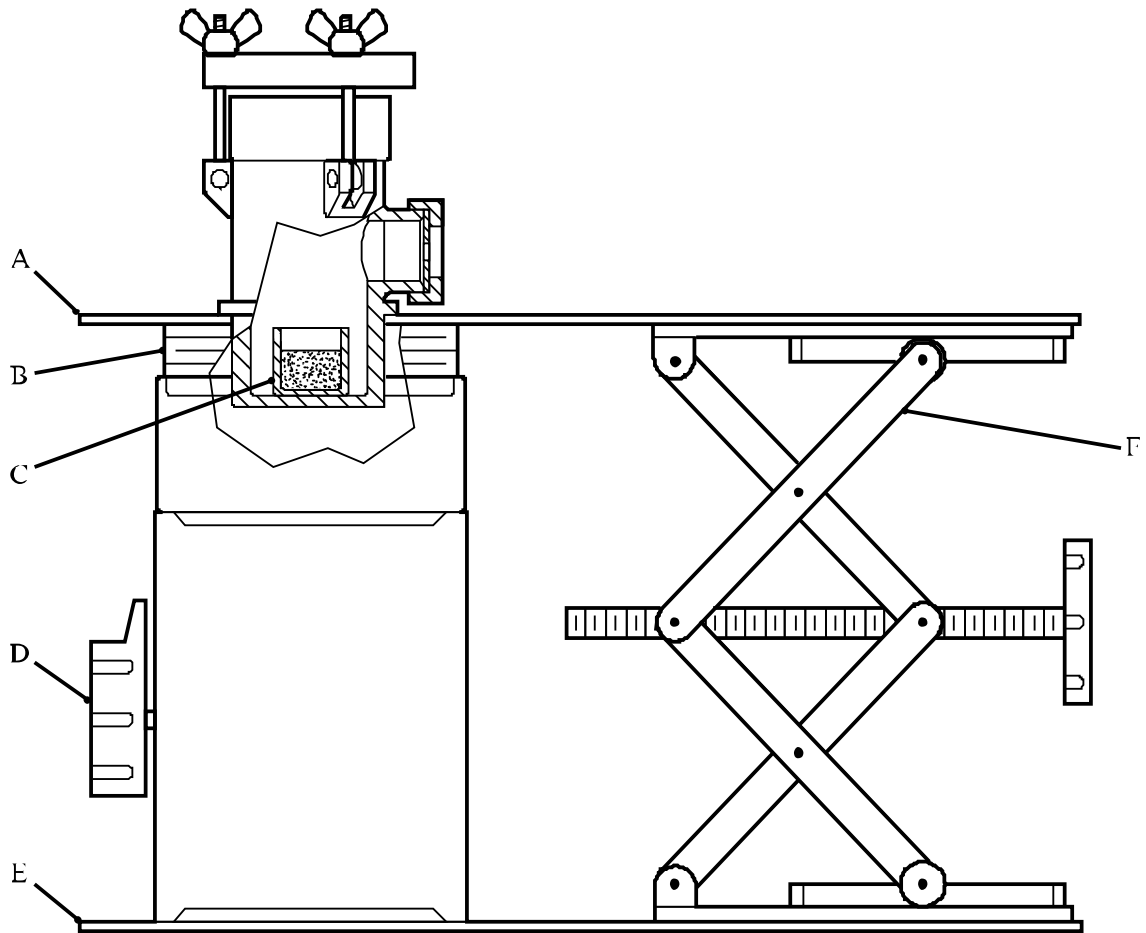

- (A) Shield
- (B) Thermal insulation
- (C) Sample cup
- (D) Electrical heater
- (E) Base
- (F) Laboratory jack

Figure 25.4.3.2: TEST APPARATUS AND STAND (side view)