

Informal document GRSP-52-28
(52nd GRSP, 11 - 14 May 2012,
agenda item 14)

**52nd GRSP, 11 – 14 Decemer 2012,
agenda item 14**

Regulation No. 29 – 03 series of amendments

Background

The scope for the Informal Group on Truck Cab Strength was

- To develop testing procedures for trucks of categories N2 with a gross vehicle mass exceeding 7.5 ton and for categories N3.
- To leave testing procedures for trucks of categories N1 and N2 with a gross vehicle mass not exceeding 7.5 ton unchanged.

Test for all categories

- "*Test A*" means a frontal impact test intended to evaluate the resistance of a cab in frontal impact accident.
- "*Test B*" means an impact test to the A-pillars of the cab intended to evaluate the resistance of a cab in a 90° rollover accident with subsequent impact.
- "*Test C*" means a cab roof strength test intended to evaluate the resistance of a cab in a 180° rollover accident.

Front impact test (test A)

Vehicle of category N₁, N₂, N₃

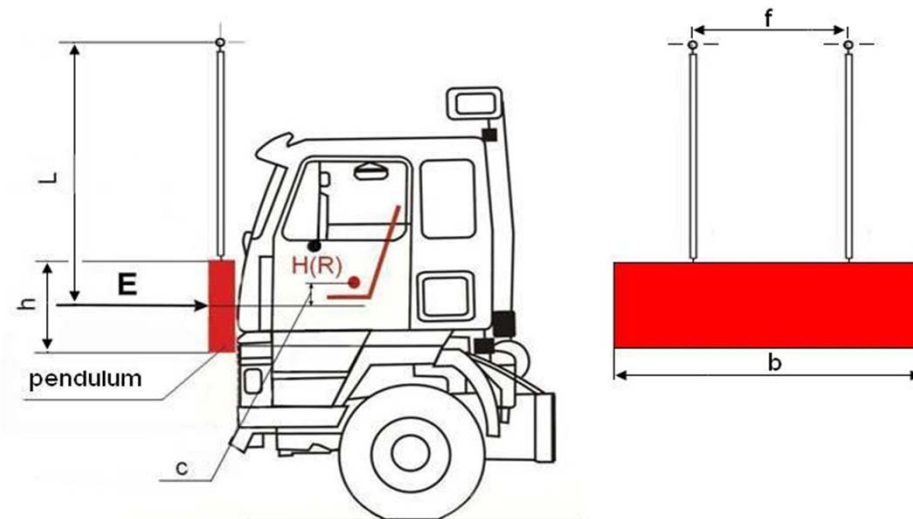

Front pillar impact test (Test B)

Vehicles of category N_2
with a gross vehicle mass
exceeding 7.5 t and of
category N_3

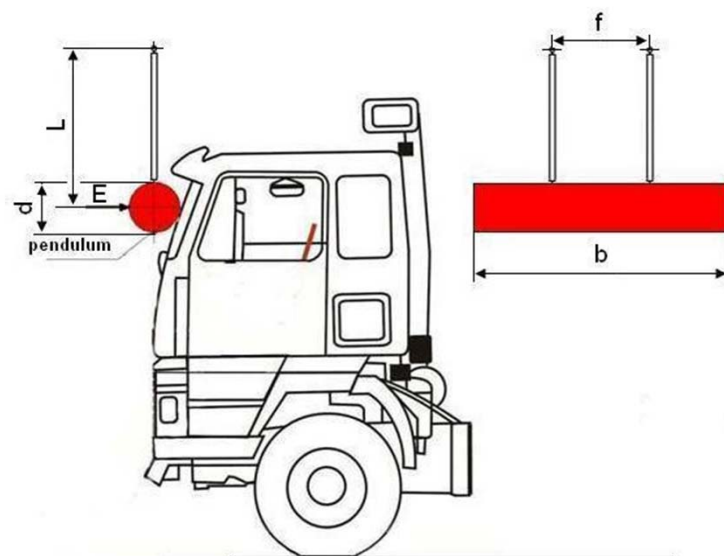

Roof strength test (Test C)

Vehicle of category N_1 , N_2 , N_3

The loading device face shall cover the whole area of the cab roof.

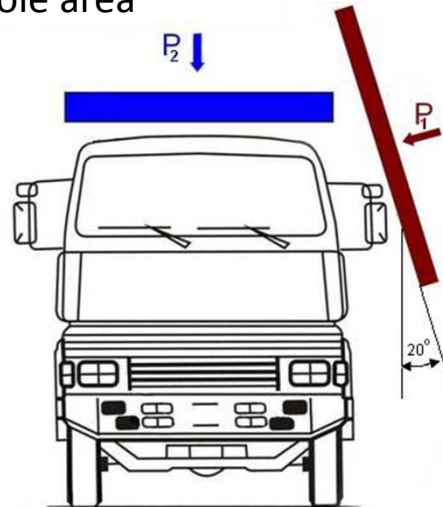

Dynamic pre-loading of vehicles of category N_2 with a gross vehicle mass exceeding 7.5 t and of category N_3

Proposal for amending GRSP/2012/19

Amend to read:

1. Scope

This Regulation applies to vehicles **of category N₃ and vehicles of category N₂ with a gross vehicle mass exceeding 7.5 t** with separate driver's cab and to **vehicles of category N₁ and vehicles of category N₂ with a gross vehicle mass not exceeding 7.5 t** of ~~category N~~ with regard to the protection of the occupants of the cab.