

**Economic and Social Council**Distr.: General  
14 June 2012

Original: English

---

**Economic Commission for Europe**

Inland Transport Committee

**World Forum for Harmonization of Vehicle Regulations****Working Party on Noise****Fifty-sixth session**

Geneva, 3–5 September 2012

Item 7(b) of the provisional agenda

**Collective amendments—Regulation Nos. 9 and 63****Proposal for the 02 series of amendments to Regulation No. 63 (Uniform provisions concerning the approval of two-wheeled mopeds with regard to noise)****Submitted by the experts of the International Motorcycle Manufacturers Association \***

The text reproduced below was prepared by the expert of the International Motorcycle Manufacturers Association (IMMA) as a consolidated version of the UN Regulation and aligning the test methods to those introduced into UN Regulation No. 41. This proposal is based on a document without symbol (GRB–55–03) distributed during the forty-fifth session of the Working Party on Noise (GRB) (ECE/TRANS/WP.29/GRB/53, para. 19). The modifications to the text of the UN Regulation are marked in bold for new or strikethrough for deleted characters.

---

\* In accordance with the programme of work of the Inland Transport Committee for 2010–2014 (ECE/TRANS/2010/8, programme activity 02.4), the World Forum will develop, harmonize and update Regulations in order to enhance the performance of vehicles. The present document is submitted in conformity with that mandate.

# I. Proposal

## Regulation No. 63

### Uniform provisions concerning the approval of two-wheeled mopeds with regard to noise

#### Contents

	<i>Page</i>
1. Scope .....	3
2. Definitions .....	3
3. Application for approval .....	4
4. Markings .....	4
5. Approval .....	5
6. Specifications .....	6
7. Modification <b>and extension of the approval</b> of the moped <b>or of the type of exhaust or silencing system</b> .....	7
8. Conformity of production.....	7
9. Penalties for non-conformity of production .....	7
10. Transitional provisions.....	8
11. Production definitely discontinued.....	8
12. Names and addresses of Technical Services responsible for conducting approval tests <sup>8</sup> and of <b>Type Approval Authorities</b> .....	8
<b>Annexes</b>	
1. <del>Communication concerning the approval or extension or refusal or withdrawal of approval or production definitely discontinued of a moped type with regard to noise, pursuant to Regulation No. 63</del> .....	10
2. Arrangements of the approval mark .....	12
3. Methods and instruments for measuring the noise made by mopeds .....	13
4. Maximum sound level limits (new mopeds) .....	28
5. Test track specifications .....	29

## 1. Scope

This Regulation applies to vehicles of category L<sub>1</sub><sup>1</sup> with regard to noise.

## 2. Definitions

For the purposes of this Regulation,

- 2.1. "*Approval of a moped*" means the approval of a moped type with regard to noise and the original exhaust system as a technical component of a two-wheeled type of moped;
- 2.2. "*Moped type*" means a category of mopeds which do not differ in such essential respects as:
- 2.2.1. the type of engine (two stroke or four stroke; with reciprocating or rotary pistons; number and capacity of cylinders; number and type of carburettors or injection systems; arrangement of valves; maximum net power and corresponding engine speed).
- For rotary piston engines, the cubic capacity should be taken to be double of the volume of the chamber;
- 2.2.2. number and ratios of gears;
- 2.2.3. the number, type and arrangement of exhaust systems;
- 2.2.3.1. "*Exhaust or silencing system*" means a complete set of components necessary for limiting the noise made by the engine of the moped and its exhaust
- 2.2.3.2. "*Original exhaust or silencing system*" means a system of the type fitted to the vehicle on approval or extension of approval. It may be original or a replacement.
- 2.2.3.3. "*Non-original exhaust or silencing system*" means a system of a type different from that fitted to the vehicle on approval or extension of approval. It may be used only as a replacement exhaust or silencing system.
- 2.3. "*Exhaust or silencing system*" means a complete set of components necessary for limiting the noise made by a moped and its exhaust;
- 2.4. "*Silencing systems of different types*" means silencing systems which differ in such essential respects as:
- 2.4.1. that their components bear different trade names or marks;
- 2.4.2. that the characteristics of the materials constituting a component are different or that the components differ in shape or size;
- 2.4.3. that the operating principles of at least one component are different;
- 2.4.4. that their components are assembled differently;

---

<sup>1</sup> As defined in the Consolidated resolution on the Construction of vehicles (R.E.3), **document ECE/TRANS/WP.29/78/Rev.2, para.2.**

- 2.5. "Exhaust system component" means one of the individual constituent parts which, when assembled, constitute the exhaust system (e.g, exhaust pipes, silencer) and, where applicable, the intake device (air filter).

If the engine is fitted with an intake device (air filter and/or an intake noise absorber essential in order to ensure conformity with noise level limits), this device shall be considered to be a component of the same importance as the exhaust system proper, and be included in the list referred to in paragraph 3.2.2. and carry the markings prescribed in paragraph 4.1.

### 3. Application for approval

- 3.1. The application for approval of a moped type with regard to noise made by mopeds shall be submitted by its manufacturer or by his duly accredited representative.
- 3.2. It shall be accompanied by the undermentioned documents in triplicate and the following particulars:
- 3.2.1. a description of the moped type with regard to the items mentioned in paragraph 2.2. above. The numbers and/or symbols identifying the engine type and the moped type shall be specified;
- 3.2.2. a list of the components, duly identified, constituting the exhaust or silencing system;
- 3.2.3. a drawing of the assembled exhaust or silencing system and an indication of its position on the moped;
- 3.2.4. detailed drawings of each component to enable it to be easily located and identified, and a specification of the materials used.
- 3.3. At the request of the technical service responsible for conducting approval tests, the moped manufacturer shall, in addition, submit a sample of the exhaust or silencing system.
- 3.4. A moped representative of the moped type to be approved shall be submitted to the technical service responsible for conducting approval tests.

### 4. Markings

- 4.1. The components of the exhaust or silencing system shall bear **at least the following identifications:**
- 4.1.1. the trade name or mark of the manufacturer of the exhaust or silencing system and of its components; ~~and~~
- 4.1.2. the trade description given by the manufacturer.
- 4.1.3. ~~All packagings of original replacements for exhaust silencing systems shall be marked "original part" and bear clearly legible make and type references.~~  
**The identifying part numbers; and**
- 4.1.4. **For all original silencers, the "E" mark followed by the identification of the country which granted the component type approval.**
- 4.1.5. **Any packing of original replacement exhaust or silencing systems shall be marked legibly with the words "original part" and the make and type**

references integrated together with the "E" mark and also the reference to the country of origin.

4.1.6. Such markings shall be indelible, clearly legible and visible, in the position on which it is to be located on the moped.

4.2. ~~Such markings shall be clearly legible and be indelible.~~

## 5. Approval

5.1. If the moped submitted for approval pursuant to paragraph 3 of this Regulation meets the requirements of paragraphs 6. and 7. ~~below~~, approval of that moped type with regard to noise shall be granted.

5.2. An approval number shall be assigned to each type approved. Its first two digits ~~(at present 01 for the 01 series of amendments entering into force on ...)~~ shall indicate the series of amendments incorporating the most recent major technical amendments made to the Regulation at the time of issue of the approval. The same Contracting Party may not assign the same number to the same moped type equipped with another type **of exhaust or** silencing system, or to another moped type.

5.3. Notice of approval or of refusal of approval of a moped type pursuant to this Regulation shall be communicated to the Parties to the Agreement which apply this Regulation, by means of a form conforming to the model in Annex 1 ~~to this Regulation~~ and of drawings of the exhaust or silencing system supplied by the applicant for approval, in a format not exceeding A4 (210 x 297 mm) or folded to that format and on an appropriate scale.

5.4. There shall be affixed, conspicuously and in a readily accessible place specified on the approval form, to every moped conforming to a moped type approved under this Regulation an international approval mark consisting of:

5.4.1. a circle surrounding the letter "E" followed by the distinguishing number of the country which has granted approval;<sup>2</sup>

5.4.2. the number of this Regulation, followed by the letter "R", a dash and the approval number to the right of the circle prescribed in paragraph 5.4.1.

5.5. If the moped conforms to a moped type approved, under one or more Regulations annexed to the Agreement, in the country which has granted approval under this Regulation, the symbol prescribed in paragraph 5.4.1. need not be repeated; in such a case the Regulation and approval numbers and the additional symbols of all the Regulations under which approval has been granted in the country which has granted approval under this Regulation shall be placed in vertical **columns** to the right of the symbol prescribed in paragraph 5.4.1.

5.6. The approval mark shall be clearly legible and be indelible.

5.7. The approval mark shall be placed close to or on the moped data plate.

5.8. Annex 2 ~~to this Regulation~~ gives arrangements of approval marks.

<sup>2</sup> The distinguish numbers of the Contracting Parties to the 1958 Agreement are reproduced in Annex 3 to Consolidated Resolution on the Construction of Vehicles (R.E.3), document ECE/TRANS/WP.29/78/Rev.2.

## 6. Specifications

- 6.1 General specifications
- 6.1.1. The moped, its engine and its exhaust or silencing system shall be so designed, constructed and assembled as to enable the moped, in normal use, despite the vibration to which it may be subjected, to comply with the provisions of this Regulation.
- 6.1.2. The **exhaust** or silencing system shall be so designed, constructed and assembled as to be able to resist the corrosive action to which it is exposed.
- 6.1.3. The following information shall be provided on the moped in an easily accessible but not necessarily immediately visible location:**
- (a) **The manufacturer's name;**
  - (b) **The target engine speed and the final result of the stationary test as defined in paragraph 3.2. of Annex 3 to this Regulation.**
- 6.2. Specifications regarding sound levels
- 6.2.1. Methods of measurement
- 6.2.1.1. The noise made by the moped type submitted for approval shall be measured by the two methods described in Annex 3 ~~to this Regulation~~ for the moped in motion and for the moped when stationary. <sup>3</sup> **In the case of a moped with an internal combustion engine that does not operate when the moped is stationary, the emitted noise shall only be measured in motion.**
- 6.2.1.2. The two values measured in accordance with the provisions of paragraph 6.2.1.1. ~~above~~ shall be entered in the test report and on a form conforming to the model in Annex 1 ~~to this Regulation~~.
- 6.2.1.3. The sound level measured by the method described in Annex 3, paragraph 3.1. ~~to this Regulation~~ when the moped is in motion shall not exceed the limits prescribed (for new mopeds and new exhaust or silencing systems) in Annex 4 ~~to this Regulation~~ for the category to which the moped belongs.
- 6.3. Additional prescriptions related to tamperability and manually adjustable multi-mode exhaust or silencing systems**
- 6.3.1. **All exhaust or silencing systems shall be constructed in a way that does not easily permit removal of baffles, exit-cones and other parts whose primary function is as part of the silencing/expansion chambers. Where incorporation of such a part is unavoidable, its method of attachment shall be such that removal is not easily facilitated (e.g. with conventional threaded fixings) and should also be attached so that removal causes permanent/irrecoverable damage to the assembly.**
- 6.3.2. **Exhaust or silencing systems with multiple, manually adjustable operating modes shall meet all requirements in all operating modes. The reported noise levels shall be those resulting from the mode with the highest noise levels.**
- 6.3.3. **The moped manufacturer shall not intentionally alter, adjust, or introduce any device or procedure solely for the purpose of fulfilling the**

---

<sup>3</sup> A test is made on a stationary moped in order to provide a reference value for administrations which use this method to check mopeds in use

noise emission requirements of this Regulation, which will not be operational during typical on-road operation.

## 7. Modifications and extension of the approval of the moped type or of the type of exhaust or silencing system(s)

- 7.1. Every modification of the moped type or of the exhaust or silencing system shall be notified to the **Type Approval Authority** which approved the moped type. The said **Authority** may then either:
- 7.1.1. consider that the modifications made are unlikely to have appreciable adverse effects; or
- 7.1.2. require a further test report from the technical service responsible for conducting the tests.
- 7.2. Confirmation or refusal of approval, specifying the alterations, shall be communicated by the procedure specified in paragraph 5.3. ~~above~~ to the Parties to the Agreement which apply this Regulation.
- 7.3. The competent authority which issued the approval extension shall assign a serial number to the extension and shall so notify the other Parties to the 1958 Agreement applying this Regulation, by means of a communication form conforming to the model in Annex 1 ~~to this Regulation~~.

## 8. Conformity of production

The conformity of production procedures shall comply with those set out in the Agreement, Appendix 2 (E/ECE/324-E/ECE/TRANS/505/Rev.2), with the following requirements:

- 8.1. Every moped bearing an approval mark as prescribed under this Regulation shall conform to the moped type approved, be fitted with the exhaust or silencing system with which it was approved and satisfy the requirements of paragraph 6. ~~above~~.
- 8.2. In order to verify conformity as prescribed in paragraph 8.1. ~~above~~, a moped, bearing the approval mark required by this Regulation, shall be taken from the series. Production shall be deemed to conform to the requirements of this Regulation if the level measured by the method described in Annex 3, paragraph 3.1. does not exceed by more than 3 dB(A) the value measured during type approval nor by more than 1 dB(A) the limits prescribed in Annex 4 ~~to this Regulation~~.

## 9. Penalties for non-conformity of production

- 9.1. The approval granted in respect of a moped type pursuant to this Regulation may be withdrawn if the requirements laid down in paragraph 8.1. ~~above~~ are not complied with, or if the moped has failed to pass the tests provided for in paragraph 8.2. ~~above~~.
- 9.2. If a Party to the Agreement which applies this Regulation withdraws an approval it has previously granted, it shall forthwith so notify the other

Parties to the 1958 Agreement applying this Regulation, by means of a communication form conforming to the model in Annex 1 ~~of this Regulation~~.

## **10. Transitional provisions**

- 10.1. As from the official date of entry into force of the **02** series of amendments, no Contracting Parties applying this Regulation shall refuse to grant ECE approval under this Regulation as amended by the **02** series of amendments.
- 10.2. As from the date of entry into force of the **02** series of amendments, Contracting Parties applying this Regulation shall grant ECE approvals only if the moped type to be approved meets the requirements of this Regulation as amended by the **02** series of amendments.
- 10.3. Contracting Parties applying this Regulation shall not refuse to grant extensions of approval in accordance with the preceding series of amendments to this Regulation.
- 10.4. Contracting Parties applying this Regulation shall continue to grant approvals to those types of mopeds which conform to the requirements of this Regulation as amended by the preceding series of amendments until the entry into force of the **02** series of amendments.
- 10.5. ECE approvals granted under this Regulation before the entry into force of the **02** series of amendments and all extensions of such approvals, including those granted subsequently under a preceding series of amendments to this Regulation, shall remain valid indefinitely. When the moped type approved under the preceding series of amendments meets the requirements of this Regulation as amended by the **02** series of amendments, the Contracting Party which granted the approval shall so notify the other Contracting Parties applying this Regulation.
- 10.6. No Contracting Party applying this Regulation shall refuse national type approval of a moped type approved under the **02** series of amendments to this Regulation or meeting the requirements thereof.
- 10.7. As from **dd mm yyyy** Contracting Parties applying this Regulation may refuse first national registration (first entry into service) of a moped which does not meet the requirements of the **02** series of amendments to this Regulation

## **11. Production definitely discontinued**

If the holder of the approval completely ceases production of a type of moped approved in accordance with this Regulation, he shall so inform the authority which granted the approval which in turn shall notify the other Parties to the 1958 Agreement applying this Regulation, by means of a copy of the communication form conforming to the model in Annex 1 ~~to this Regulation~~.

## **12. Names and addresses of technical services conducting approval tests and of Type Approval Authorities**

The Parties to the Agreement which apply this Regulation shall communicate to the United Nations Secretariat the names and addresses of the technical



services responsible for conducting approval tests and of the **Type Approval Authorities** which grant approval and to which forms certifying approval or extension or refusal or withdrawal of approval or production definitely discontinued, issued in other countries, are to be sent.

# Annex 1

## Communication

(maximum format: A4 (210 x 297 mm))

issued by: Name of administration:  
 .....  
 .....  
 .....



concerning:<sup>2</sup> APPROVAL GRANTED  
 APPROVAL EXTENDED  
 APPROVAL REFUSED  
 APPROVAL WITHDRAWN  
 PRODUCTION DEFINITELY DISCONTINUED

of a vehicle type with regard to its noise emission pursuant ECE to Regulation No. 63

Approval No. .... Extension No. ....

1. Trade name or mark of the moped .....
2. Moped type .....
3. Variant(s) (if applicable): .....
4. Version(s) (if applicable): .....
5. Name and address of manufacturer: .....
6. Name and address of manufacturer's representative (if applicable): .....
7. Type(s) of original exhaust system(s): .....
8. Type(s) of intake device(s) (if required in order to ensure conformity with noise-level limits): .....
9. **Type** of engine<sup>3</sup> .....
10. Cycles: 2-stroke or 4-stroke (if applicable)<sup>2</sup> .....
11. Cylinder capacity .....
- 11.1. Bore .....mm
- 11.2. Stroke.....mm
12. Engine power (state how measured) .....
13. Engine speed at which maximum power is developed ..... min-1

<sup>1</sup> Distinguishing numed/withdrawn approval (see approval provisions in the Regulation).

<sup>2</sup> Strike out what does not apply

<sup>3</sup> If a non-conventional engine is used, this should be stated.

- 
14. Number of gears .....
- 14.1. gears used .....
- 14.2. final drive ratio(s) .....
15. Type and dimensions of tyres .....
16. Maximum permissible gross weight .....kg
17. Maximum design speed (as indicated by the manufacturer).....km/h
18. For stationary moped test: location and orientation of the microphone (by reference to diagrams in appendix to annex 3)
19. Sound levels:.....
- Moped in motion .....dB(A)
- at approach speed (Line A-A') of ..... km/h,
- rotation speed of the engine ..... (**min-1**)
- Moped stationary ..... dB(A)
- with engine running at ..... (**min-1**)
20. Deviations in calibration of sound- level meter .....
21. Moped submitted for approval on .....
22. Technical service responsible for conducting approval tests .....
23. Date of report issued by that service .....
24. Number of report issued by that service .....
25. Approval granted/refused/extended/withdrawn <sup>2</sup> .....
26. Position of approval mark on the moped .....
27. Place .....
28. Date.....
29. Signature .....
- 30 The following documents, bearing the approval number shown above, are annexed to this communication
- (a) drawings, diagrams and plans of the engine and of the exhaust or silencing system;
- (b) photographs of the engine and of the exhaust or silencing system;
- (c) list of duly identified components constituting the exhaust or silencing system.

## Annex 2

### Arrangements of the approval mark

Model A

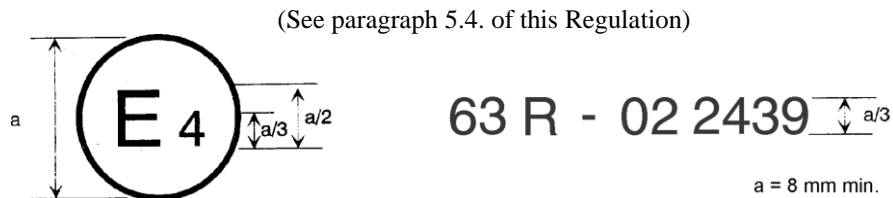

The above approval mark affixed to a vehicle shows that the vehicle type concerned has, with regard to its noise emission, been approved in the Netherlands (E 4) pursuant to Regulation No. 63 under approval No. 022439. The approval number indicates that the approval was granted according to the requirements of Regulation No. 63 as amended by the 02 series of amendments.

Model B

(See paragraph 5.5. of this Regulation)

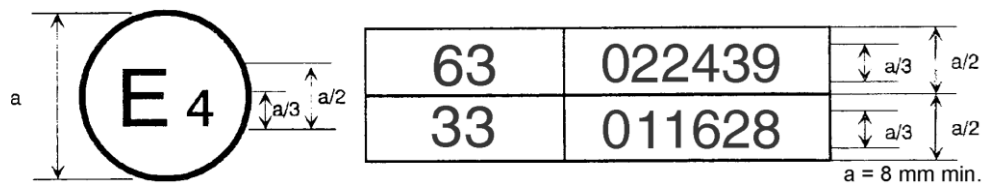

The above approval mark affixed to a vehicle shows that the vehicle type concerned has been approved in the Netherlands (E 4) pursuant to Regulation Nos. 63 and 33.<sup>1</sup> The approval numbers indicate that, at the dates when the respective approvals were given, Regulation No. 63 included the 02 series of amendments and Regulation No. 33 has also been amended by the 01 series of amendments.

<sup>1</sup> The second number is given merely as an example.

## Annex 3

### Methods and instruments for measuring the noise made by mopeds

#### 1. Measuring instruments

##### 1.1. Acoustic measurements

~~1.1.1. The apparatus used for measuring the sound level shall be a precision sound-level meter of the type described in International Electrotechnical Commission (IEC) publication No. 179 "Precision sound level meters", second edition~~

~~1.1.2. Measurements shall be carried out using the "fast" response of the sound-level meter and the "A" weighting also described in that publication.~~

##### 1.1.1. General

The apparatus used for measuring the sound pressure level shall be a sound level meter or equivalent measuring system meeting the requirements of Class 1 instruments (inclusive of the recommended windscreen, if used). These requirements are described in IEC 61672 1:2002. Measurements shall be carried out using the time weighting "F" of the acoustic measuring instrument and the "A" frequency weighting curve also described in IEC 61672-1:2002. When using a system that includes periodic monitoring of the A-weighted sound pressure level, a reading should be made at a time interval not greater than 30 ms. The instruments shall be maintained and calibrated in accordance with the instructions of the instrument manufacturer.

~~1.1.3. At the beginning and end of each series of measurements the sound-level meter shall be calibrated in accordance with the manufacturer's instructions, using an appropriate sound source (e.g. pistonphone).~~

##### 1.1.2. Calibration

At the beginning and at the end of every measurement session, the entire acoustic measuring system shall be checked by means of a sound calibrator that fulfils the requirements of Class 1 sound calibrators according to IEC 60942:2003. Without any further adjustment, the difference between the readings shall be less than or equal to 0.5 dB(A). If this value is exceeded, the results of the measurements obtained after the previous satisfactory check shall be discarded.

##### 1.1.3. Compliance with requirements

Compliance of the sound calibrator with the requirements of IEC 60942:2003 shall be verified once a year. Compliance of the instrumentation system with the requirements of IEC 61672-1:2002 shall be verified at least every 2 years. All compliance testing shall be conducted by a laboratory which is authorized to perform calibrations traceable to the appropriate standards.

~~1.1.4. If the errors of the sound level meter obtained from these calibrations change by more than 1 dB during a series of measurements, the test shall be considered invalid.~~

1.2. ~~Speed measurements~~ **Instrumentation for speed measurements**

~~Engine revolution and the speed of the moped on the test track shall be determined to within  $\pm 3\%$ .~~

**The rotational speed of the engine shall be measured with an instrument meeting specification limits of at least  $\pm 2$  per cent or better at the engine speeds required for the measurements being performed.**

**The road speed of the vehicle shall be measured with instruments meeting specification limits of at least  $\pm 0.5$  km/h when using continuous measuring devices. If testing uses independent measurements of speed, this instrumentation shall meet specification limits of at least  $\pm 0.2$  km/h.<sup>1</sup>**

1.5. **Meteorological instrumentation**

**The meteorological instrumentation used to monitor the environmental conditions during the test shall meet the following specifications:**

**$\pm 1$  °C or less for a temperature measuring device;**

**$\pm 1.0$  m/s for a wind speed measuring device;**

**$\pm 5$  hPa for a barometric pressure measuring device;**

**$\pm 5$  per cent for a relative humidity measuring device.**

## 2. Conditions of measurement

2.1. Site

2.1.1. The test site shall consist of a central acceleration track surrounded by a substantially level test area. The test track shall be level; the track surface shall be dry and so designed that rolling noise remains low.

On the test site, free sound field conditions shall be maintained to within 1 dB between the sound source placed in the middle of the acceleration section and the microphone. This condition shall be deemed to be met if there are no large sound reflecting objects such as hedges, rocks, bridges or buildings within 50 metres of the centre of the acceleration section.

No obstacle likely to affect the sound field shall be close to the microphone and no one shall come between the microphone and the sound source. The observer taking the measurements shall take up position so as to avoid influencing the metre readings.

2.1.2. The surface of the test track shall conform to the requirements of Annex 5.

2.1.3. Miscellaneous

<sup>1</sup> Independent measurements of speed are when two or more separate devices will determine the values of vAA' and vBB'. A continuous measuring device such as radar will determine all required speed information with one device.

Measurements shall not be made in poor weather conditions. ~~Precautions shall be taken to ensure that readings are not influenced by wind gusts.~~ **The tests shall not be carried out if the wind speed, including gusts, exceeds 5 m/s during the sound-measurement interval.**

For measurement purposes, the weighted sound-level (A) of sound sources on the test vehicle and the sound-level produced by the effect of the wind shall be at least 10 dB(A) below the noise-level produced by the vehicle. The microphone may be fitted with a suitable wind guard, provided that its influence on the sensitivity and directional characteristics of the microphone are taken into account.

If the difference between ambient and measured noise-levels is between 10 and 16 dB(A), the appropriate figure shall be subtracted from the value recorded by the sound-level metre, in accordance with the following graph: 15 dB(A), in order to calculate the test result the appropriate correction shall be subtracted from the readings on the sound level meter, **as given in Table 1.**

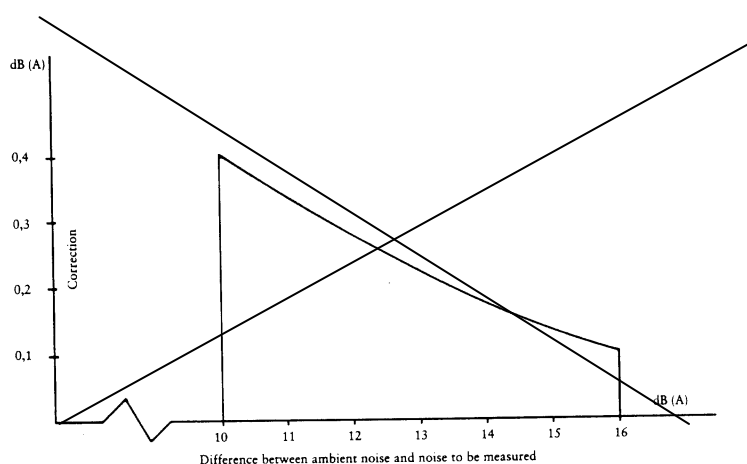

Table 1  
**Correction applied to individual measured test value**

Background sound pressure level difference to measured sound pressure level, in dB	10	11	12	13	14	≥ 15
Correction, in dB(A)	0.5	0.4	0.3	0.2	0.1	0.0

## 2.2. Moped

- 2.2.1. The combined mass of the driver and test equipment used on the moped shall not be more than 90 kg nor less than 70 kg. Weights shall be placed on the moped if the 70 kg minimum is not reached. While measurements are being taken, the moped shall be equipped as for normal road use (with coolant, lubricants, fuel, tool kit, spare wheel and driver).

- 2.2.2. ~~The tyres of the moped shall be of the correct size and shall be inflated to the prescribed pressure(s) for the moped in its unladen condition.~~

**Tyre selection and condition**

**The tyres shall be appropriate for the moped and shall be inflated to the pressure recommended by the moped manufacturer for the test mass of the moped.**

**The tyres shall be selected by the moped manufacturer, and correspond to one of the tyre sizes and types designated for the moped by the moped manufacturer. The minimum tread depth shall be at least 80 per cent of the full tread depth.**

- 2.2.3. Before the measurements are started, the engine shall be brought to its normal operating conditions as regards:
- 2.2.3.1. temperatures
  - 2.2.3.2. tuning
  - 2.2.3.3. fuel
  - 2.2.3.4. sparking plugs, carburettor(s), etc., (as appropriate).
- 2.2.4. If the moped is equipped with devices which are not necessary for its propulsion, but which are used whilst the moped is in normal service on the road, those devices shall be in operation in accordance with the specifications of the manufacturer.

### **3. Methods of testing**

- 3.1. Measurement of noise of mopeds in motion
- 3.1.1. General conditions of test
    - 3.1.1.1. At least two measurements shall be made on each side of the moped.  
  
Preliminary measurements may be made for adjustment purposes, but shall be disregarded.
    - 3.1.1.2. ~~The microphone shall be situated 1.2 m ± 0.1 m above ground level at a distance of 7.5 m ± 0.2 m from the path of the moped's centre line, measured along the perpendicular PP' to that line (see appendix, fig. 1).~~  
  
**The distance of the microphone positions from the line CC', on the microphone line PP', perpendicular to the reference line CC' on the test track (see appendix, figure 1), shall be 7.5 ± 0.05 m.**  
  
**The microphones shall be located 1.2 ± 0.02 m above the ground level. The reference direction for free-field conditions (see IEC 61672-1:2002) shall be horizontal and directed perpendicularly towards the path of the moped line CC'.**
    - 3.1.1.3. Two lines, AA' and BB', parallel to the microphone line PP' and situated respectively 10 m forward and 10 m rearward of that line shall be marked out on the test track. The moped shall approach line AA' at an initial steady speed as specified below. When the front of the moped reaches line AA' the throttle shall be fully opened as quickly as practically possible and kept in



that position until the rear of the moped reaches line BB'; the throttle ~~must~~ **shall** then be returned as quickly as possible to the idle position.

For all measurements, the moped shall be driven in a straight line along the test track in such a way that the track of the median longitudinal plane of the moped is as close as possible to the line CC'.

3.1.1.4. The maximum sound value recorded at each measurement shall constitute the result of the measurement. The measurements shall be considered valid if the difference between the two consecutive measurements on the same side of the moped is not more than 2 dB(A).

3.1.2. Determination of the approach speed

3.1.2.1. Approach speed

The moped shall approach the line AA' at a steady speed equal to its maximum speed if the latter is below or equal to 30 km/h. If the maximum speed is above 30 km/h, the vehicle shall approach AA' at a steady speed of 30 km/h.

3.1.2.2. If the moped is fitted with a manually-operated gearbox, the highest gear shall be selected which enables it to pass over the line AA' with an engine speed above or equal to one half the engine speed at which the engine produces its maximum power.

3.1.2.3. If the moped is fitted with automatic transmission, it shall be driven at the speeds indicated in 3.1.2.1.

3.2. Measurement of noise emitted by stationary mopeds (conditions and method of measurement for testing vehicles in service).

In addition, in order to facilitate subsequent testing of mopeds in service, the sound pressure level shall be measured close to the outlet of the exhaust (silencing) system, in accordance with the following requirements, and the reading shall be recorded in the test report prepared for the issue of the document referred to in Annex 1.

The measurements shall be made using a precision sound-level metre conforming to the requirements of paragraph 1 **of Annex 3**.

3.2.1. ~~Measurement of noise emitted by stationary mopeds~~ Test site - local conditions (see appendix, figure 2)

3.2.1.1. Measurements shall be made on a stationary moped in an area which does not present a great deal of disturbance to the sound field.

3.2.1.2. Every open space shall be considered as a suitable test site if it consists of a flat area covered with concrete, asphalt or some other hard material having a high reflective capacity, excluding compressed or other earth surfaces, in which one can trace a rectangle whose sides are at least ~~three metres~~ **3 m** from the extremities of the moped and inside which there is no noticeable obstacle; in particular, the moped shall not be positioned at a distance of less than 1 m from a pavement edge when the exhaust noise is measured.

3.2.1.3. Nobody shall be in the measurement area, except the observer and the driver, whose presence ~~must~~ **shall** have no influence on the meter reading.

3.2.2. Disturbance noise and wind interference

The ambient noise levels at each measuring point shall be at least 10 dB(A) below the levels measured during the tests at the same points.

3.2.3. Measuring method

3.2.3.1. Nature and number of measurements

The maximum sound level expressed in A-weighted decibels (dB(A)) shall be measured during the period of operation laid down in paragraph 3.2.3.3.2.1. ~~below.~~

At least three measurements shall be taken at each measuring point.

3.2.3.2. Position and preparation of the moped

Before the measurements are started, the moped engine shall be brought to its normal operating temperature. If the moped is equipped with automatic fans, no adjustment shall be made to them during the measurement of the noise level.

While measurements are being made, the gear lever shall be in neutral. If the transmission cannot be disconnected, the drive wheel of the moped should be allowed to run under no-load conditions by, for example, placing the moped on its stand.

3.2.3.3. Measuring of noise in proximity to the exhaust (~~see appendix, figure.2~~)

3.2.3.3.1. Position of the microphone

~~3.2.3.3.1.1. The height of the microphone above the ground must be equal to that of the outlet pipe of the exhaust gases, but in any event shall be limited to a minimum value of 0.2 m.~~

~~3.2.3.3.1.2. The microphone must be pointed towards the orifice of the gas flow and located at a distance of 0.5 m from the orifice.~~

~~3.2.3.3.1.3. Its axis of maximum sensitivity must be parallel to the ground and must make an angle of  $45 \pm 100$  with the vertical plane containing the direction of the gas flow. The instructions of the manufacturer of the sound level meter with regard to this axis must be respected. In relation to this plane, the microphone shall be placed in such a way as to obtain the maximum distance from the longitudinal median plane of the moped; in case of doubt, the position which gives the maximum distance from the contour of the moped shall be selected.~~

~~3.2.3.3.1.4. In the case of an exhaust provided with two or more outlets spaced less than 0.3 m apart, only one measurement is made; the microphone position is related to the outlet nearest to the external side of the moped or, when such outlet does not exist, to the outlet which is the highest above the ground.~~

~~3.2.3.3.1.5. For mopeds having an exhaust provided with outlets spaced more than 0.3 m apart, one measurement is made for each outlet as if it were the only one, and the highest level is noted.~~

**The microphone shall be located at a distance of  $0.5 \pm 0.01$  m from the reference point of the exhaust pipe defined in Figure 4 and at an angle of  $45 \pm 5^\circ$  to the vertical plane containing the flow axis of the pipe termination. The microphone shall be at the height of the reference point, but not less than 0.2 m from the ground surface. The reference axis of the microphone shall lie in a plane parallel to the ground surface and shall be directed towards the reference point on the exhaust outlet.**

The reference point shall be the highest point satisfying the following conditions:

- (a) The reference point shall be at the end of the exhaust pipe,
- (b) The reference point shall be on the vertical plane containing the exhaust outlet centre and the flow axis of the exhaust pipe termination.

If two microphone positions are possible, the location farthest laterally from the moped longitudinal centreline shall be used. If the flow axis of the exhaust outlet pipe is at  $90^\circ \pm 5^\circ$  to the moped longitudinal centreline, the microphone shall be located at the point that is the furthest from the engine.

If a moped has two or more exhaust outlets spaced less than 0.3 m apart and connected to a single silencer, only one measurement shall be made.

The microphone shall be located relative to the outlet the farthest from the moped's longitudinal centreline, or, when such outlet does not exist, to the outlet that is highest above the ground.

For mopeds having an exhaust provided with outlets spaced more than 0.3 m apart, one measurement is made for each outlet as if it were the only one, and the highest sound pressure level shall be noted. For the purpose of roadside checking, the reference point may be moved to the outer surface of the moped body.

3.2.3.3.2. Operating conditions of the engine

3.2.3.3.2.1. Engine speed shall be held steady at one of the following values:

$\frac{1}{2} S$ , if  $S$  exceeds 5,000 ~~rpm~~,  $\text{min}^{-1}$

$\frac{3}{4} S$ , if  $S$  does not exceed 5,000 ~~rpm~~,  $\text{min}^{-1}$

where  $S$  is the engine speed at which the engine produces its maximum power.

**For a moped which cannot reach, in a stationary test, the target engine speed defined above, 95 per cent of the maximum engine speed reachable in a stationary test shall be used instead as target engine speed.**

3.2.3.3.2.2. ~~When the constant engine speed is reached, the throttle shall be returned swiftly to the idle position. The sound level shall be measured during a period of operation consisting of a brief maintenance of the constant engine speed and throughout the deceleration period.~~

The engine speed shall be gradually increased from idle to the target engine speed and held constant within a tolerance band of  $\pm 5$  per cent. Then the throttle control shall be rapidly released and the engine speed shall be returned to idle. The sound pressure level shall be measured during a period consisting of constant engine speed of at least 1 s and throughout the entire deceleration period. The maximum sound level meter reading shall be taken as the test value.

A measurement shall be valid only if the test engine speed did not deviate from the target engine speed by more than the specified tolerance of  $\pm 5$  per cent for at least 1 s.

3.2.3.3.2.3. Multi-mode exhaust system

**Mopeds equipped with a multiple mode, manually adjustable exhaust system shall be tested in all modes.**

**3.2.3.3.3. Result**

~~The values rounded off to the nearest whole decibel, shall be read from the measuring apparatus. If the figure following the decimal point is between 0 and 4, the total is rounded down and if between 5 and 9, it is rounded up.~~

~~Only values which are obtained from three consecutive measurements which do not differ by more than 2 dB(A) shall be accepted.~~

~~The highest of the three measurements will constitute the test result.~~

**3.2.3.3.3.1. Measurements shall be made at the microphone location(s) prescribed above. The maximum A-weighted sound pressure level indicated during the test shall be noted, retaining one significant figure behind the decimal place (e.g. 92.45 shall be noted as to 92.5 while 92.44 shall be noted as to 92.4). The test shall be repeated until three consecutive measurements that are within 2.0 dB(A) of each other are obtained at each outlet.**

**The result for a given outlet is the arithmetic average of the three valid measurements, mathematically rounded to the nearest integer value (e.g. 92.5 shall be noted as to 93 while 92.4 shall be noted as to 92).**

**3.2.3.3.3.2. For mopeds equipped with multiple exhaust outlets, the reported sound pressure level shall be for the outlet having the highest average sound pressure level.**

**3.2.3.3.3.3. For mopeds equipped with a multi-mode exhaust system and a manual exhaust mode control the reported sound pressure level shall be for the mode having the highest average sound pressure level.**

## **4. Interpretation of results for vehicles in motion**

The values taken shall be rounded off to the nearest whole decibel. If the figure following the decimal point is between 0 and 4, the total is rounded down and if between 5 and 9, it is rounded up.

Only the values of readings obtained from two consecutive measurements made on the same side of the vehicle and not differing by more than 2 dB(A) shall be accepted.

To allow for lack of precision in the readings, the result of each measurement shall be taken as equal to the value obtained, less 1 dB(A).

If the average of the four readings does not exceed the maximum permissible level for the category to which the tested vehicle belongs, the limit specified in paragraph 6.2.1.3. shall be deemed as being complied with. This average value shall constitute the test result.

Figure 1.  
Measuring positions for vehicles in motion

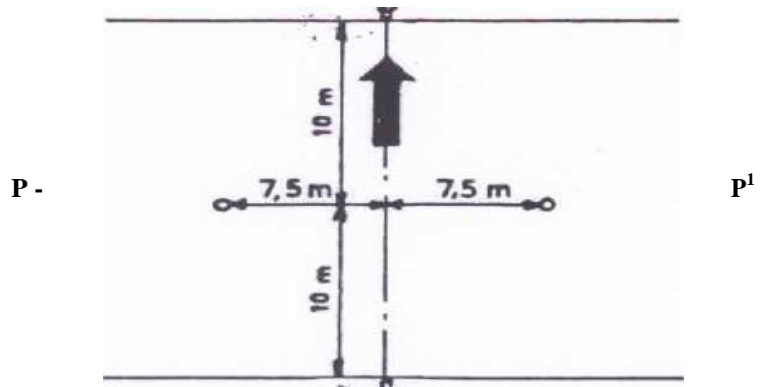
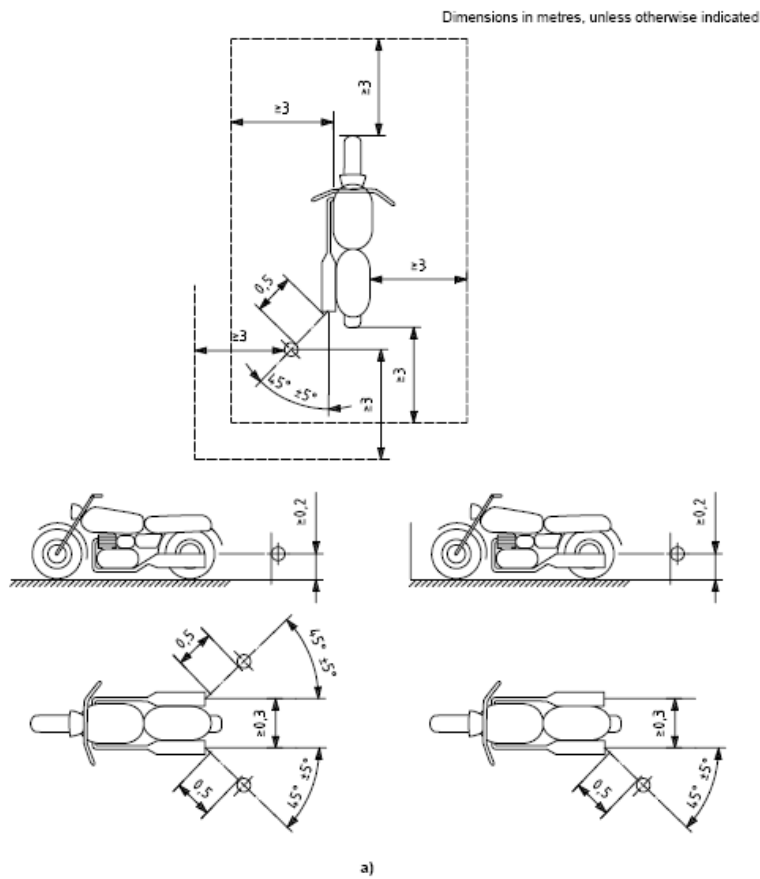

Figure 2.  
Measuring positions for stationary mopeds



## 5. Original exhaust (silencing) system

- 5.1. Requirements for silencers containing absorbent fibrous materials.
- 5.1.1. Fibrous absorbent material ~~must~~ **shall** be asbestos-free and may be used in the construction of silencers only if suitable devices ensure that the fibrous absorbent material is kept in place for the whole time that the silencer is being used and it meets the requirements of any one of sections 5.1.2., 5.1.3. or 5.1.4.
- 5.1.2. After removal of the fibrous material, the sound level ~~must~~ **shall** conform to the requirements of Annex 4.
- 5.1.3. The fibrous absorbent material may not be placed in those parts of the silencer through which the exhaust gases pass and ~~must~~ **shall** conform to the following requirements:
- 5.1.3.1. The material shall be heated at a temperature of  $650 \pm 5^\circ \text{C}$  for four hours in a furnace without reduction in the average length, diameter or bulk density of the fibre;
- 5.1.3.2. After heating at  $650 \pm 5^\circ \text{C}$  for one hour in a furnace, at least 98% **per cent** of the material ~~must~~ **shall** be retained in a sieve of nominal aperture size 250  $\mu\text{m}$  conforming to ISO ~~standard 3310/1: 1990~~ **standard 2599 2559:2000**;
- 5.1.3.3. The loss in weight of the material ~~must~~ **shall** not exceed 10.5% **per cent** after soaking for 24 hours at  $90 \pm 5^\circ \text{C}$  in a synthetic condensate of the following composition:
- 1 N hydrobromic acid (HBr) 10 ml
- 1 N sulphuric acid ( $\text{H}_2\text{SO}_4$ ) 10 ml
- Distilled water to make up to 1,000 ml
- ~~Note:~~The material ~~must~~ **shall** be washed in distilled water and dried for one hour at  $105^\circ \text{C}$  before weighing.
- 5.1.4. Before the system is tested in accordance with paragraph 3.1., it ~~must~~ **shall** be put into a normal state for road use by one of the following methods:
- 5.1.4.1. Conditioning by continuous road operation.
- 5.1.4.1.1. The minimum distance to be completed during conditioning shall be 2,000 km.
- 5.1.4.1.2. 50 % **per cent**  $\pm$  10 % **per cent** of this conditioning cycle shall consist of town driving and the remainder of long-distance runs; the continuous road cycle may be replaced by a corresponding test-track programme.
- 5.1.4.1.3. The two speed regimes ~~must~~ **shall** be alternated at least six times.
- 5.1.4.1.4. The complete test programme ~~must~~ **shall** include a minimum of 10 breaks of at least three hours' duration in order to reproduce the effects of cooling and condensation.
- 5.1.4.2. Conditioning by pulsation.
- 5.1.4.2.1. The exhaust system or components thereof ~~must~~ **shall** be fitted to the moped or to the engine.

In the former case, the moped ~~must~~ **shall** be mounted on a roller dynamometer. In the second case, the engine ~~must~~ **shall** be mounted on a test bench.

The test apparatus, a detailed diagram of which is shown in figure 3, shall be fitted at the outlet of the exhaust system. Any other apparatus providing equivalent results shall be acceptable.

- 5.1.4.2.2. The test equipment ~~must~~ **shall** be adjusted so that the flow of exhaust gases is alternately interrupted and restored 2,500 times by a rapid-action valve.
- 5.1.4.2.3. The valve ~~must~~ **shall** open when the exhaust gas back-pressure, measured at least 100 mm downstream of the intake flange, reaches a value of between ~~0.35 and 0.40 bar~~ **35 and 40 kPa**. Should such a figure be unattainable because of the engine characteristics, the valve ~~must~~ **shall** open when the gas back-pressure reaches a level equivalent to 90% **per cent** of the maximum that can be measured before the engine stops. It ~~must~~ **shall** close when this pressure does not differ by more than 10% **per cent** from its stabilized value with the valve open.
- 5.1.4.2.4. The time-delay switch ~~must~~ **shall** be set for the duration of exhaust gases calculated on the basis of the requirements of paragraph 5.1.4.2.3. ~~above~~.
- 5.1.4.2.5. Engine speed ~~must~~ **shall** be 75% **per cent** of the speed (S) at which the engine develops maximum power.
- 5.1.4.2.6. The power indicated by the dynamometer ~~must~~ **shall** be 50% **per cent** of the full-throttle power measured at 75% **per cent** of engine speed (S).
- 5.1.4.2.7. Any drainage holes ~~must~~ **shall** be closed off during the test.
- 5.1.4.2.8. The entire test ~~must~~ **shall** be completed within 48 hours. If necessary, a cooling period ~~must~~ **shall** be allowed after each hour.
- 5.1.4.3. Conditioning on a test bench
  - 5.1.4.3.1. The exhaust system ~~must~~ **shall** be fitted to an engine representative of the type fitted to the moped for which the system is designed, and mounted on a test bench.
  - 5.1.4.3.2. Conditioning shall consist of three cycles.
  - 5.1.4.3.3. Each test-bench cycle ~~must~~ **shall** be followed by a break of at least six hours in order to reproduce the effects of cooling and condensation.

- 5.1.4.3.4. Each test-bench cycle shall consist of six phases. The engine conditions for and the duration of each phase shall be:

<i>Phase</i>	<i>Conditions</i>	<i>Duration of phase in minutes</i>
1	Idling	6
2	25 % load at 75 % <i>S</i>	40
3	50 % load at 75 % <i>S</i>	40
4	100 % load at 75 % <i>S</i>	30
5	50 % load at 100 % <i>S</i>	12
6	25 % load at 100 % <i>S</i>	22
	Total time	2 hrs-30 mins

- 5.1.4.3.5. During this conditioning procedure, at the request of the manufacturer, the engine and the silencer may be cooled in order that the temperature recorded at a point not more than 100 mm from the exhaust gas outlet does not exceed that measured when the moped is running at 75% **per cent** of *S* in top gear. The engine and/or moped speeds shall be determined to within  $\pm 3\%$  **per cent**.

5.2. Diagram and markings

- 5.2.1. The diagram and a dimensioned cross section of the silencer shall be annexed to the document mentioned in Annex 1.

~~5.2.2. All original silencing systems shall be marked with clearly legible and indelible make and type references.~~

~~5.2.3. Any packaging of original replacements for exhaust or silencing systems shall be marked legibly with the words "original part" and the make and type reference integrated together with the "E" mark and also the reference of the country of origin.~~

5.3. Intake silencers

If the engine intake has to be fitted with an air filter and/or intake silencer in order to comply with the permissible sound level, the filter and/or silencer shall be regarded as part of the silencer and the requirements of paragraphs 5.1. and 5.2. shall also be applicable to them.



### Annex 3 – Appendix

Measuring positions for mopeds in motion

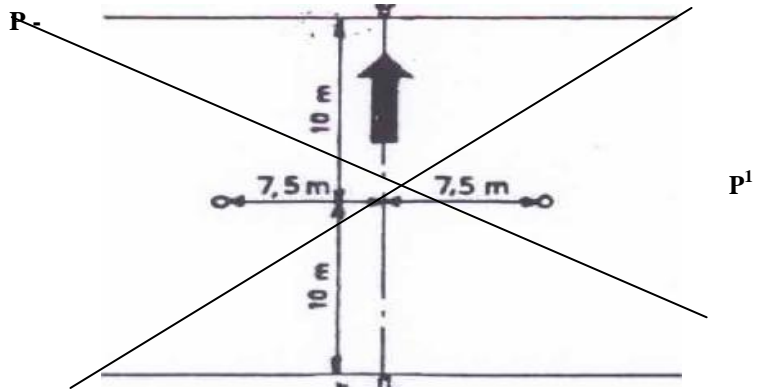

Fig-1

Measuring positions for stationary mopeds

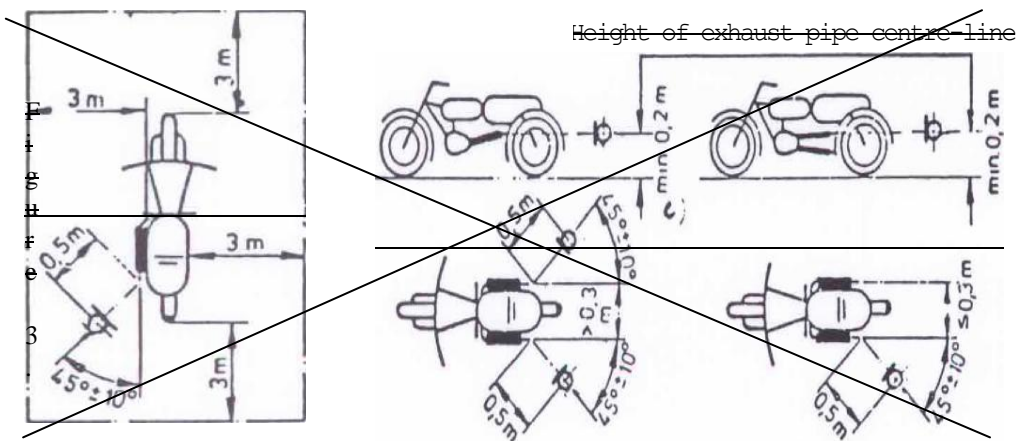
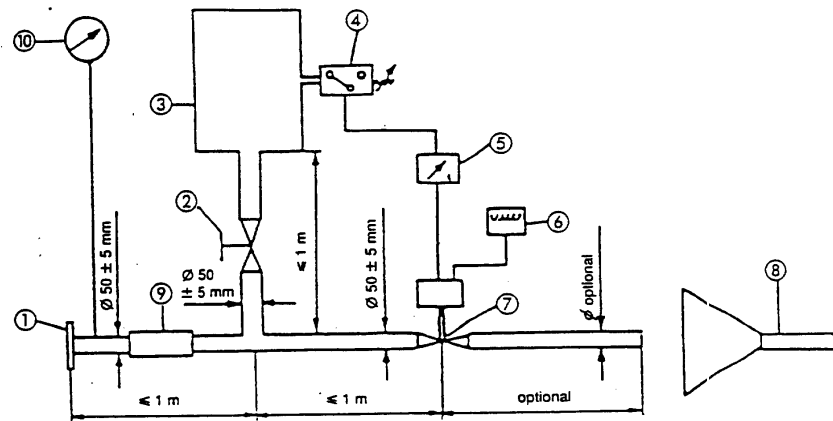

Fig-2

Figure 3  
Test apparatus for conditioning by pulsation



1. Inlet flange or sleeve for connection to the rear of the test exhaust system.
2. Hand-operated regulating valve.
3. Compensating reservoir with a maximum capacity of 40 l and a filling time of not less than one second.
4. Pressure switch with an operating range of ~~0.05 to 2.5 bar~~ **5 to 250 kPa**.
5. Time delay switch.
6. Pulse counter.
7. Quick-acting valve, such as exhaust brake valve 60 mm in diameter, operated by a pneumatic cylinder with an output of 120 N at ~~4 bar~~ **400 kPa**. The response time, both when opening and closing, ~~must~~ **shall** not exceed 0.5 seconds.
8. Exhaust gas evacuation.
9. Flexible pipe.
10. Pressure gauge

Figure 4.  
Reference point

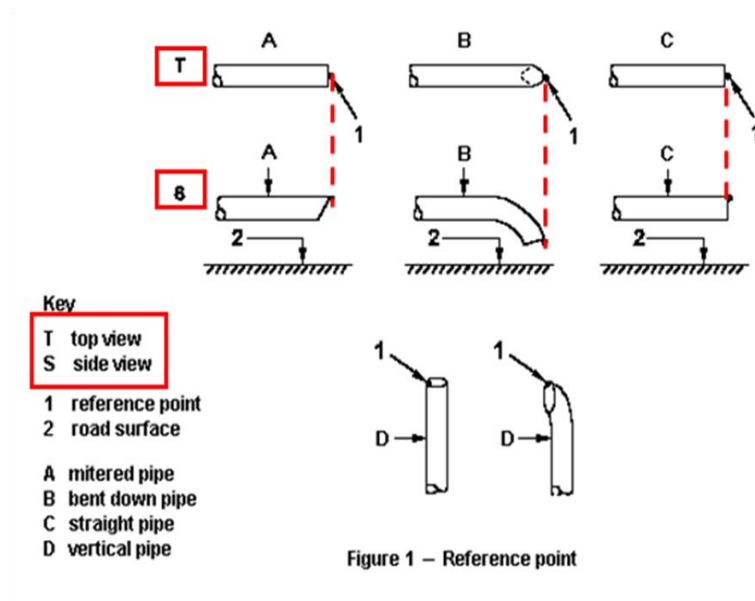

## Annex 4

### Maximum sound level limits (new mopeds)

<i>Category of two-wheeled mopeds</i>	<i>Maximum noise-level values in dB(A)</i>
≤ 25 km/h	66
> 25 km/h	71

## Annex 5

### Test track specifications

#### 1. Introduction

This Annex describes the specifications relating to the physical characteristics and the laying of the test track. These specifications based on a special standard <sup>1</sup> describe the required physical characteristics as well as the test methods for these characteristics.

#### 2. Required characteristics of the surface

A surface is considered to conform to this standard provided that the texture and voids content or sound absorption coefficient have been measured and found to fulfill [all] the requirements of paragraphs 2.1. to 2.4. ~~below~~ and provided that the design requirements (paragraph 3.2.) have been met.

##### 2.1. Residual voids content

The residual voids content,  $V_C$ , of the test track paving mixture shall not exceed **8% per cent**. For the measurement procedure, see paragraph 4.1.

##### 2.2. Sound absorption coefficient

If the surface fails to conform to the residual voids content requirement, the surface is acceptable only if its sound absorption coefficient,  $\alpha \leq 0.10$ . For the measurement procedure, see paragraph 4.2. The requirement of paragraphs 2.1. and 2.2. is met also if only sound absorption has been measured and found to be  $\alpha \leq 0.10$ .

Note: The most relevant characteristic is the sound absorption, although the residual voids content is more familiar among road constructors. However, sound absorption needs to be measured only if the surface fails to comply with the voids requirement. This is because the latter is connected with relatively large uncertainties in terms of both measurements and relevance and some surfaces therefore may be rejected erroneously when the voids measurement only is used as a basis.

##### 2.3. Texture depth

The texture depth (TD) measured according to the volumetric method (see paragraph 4.3. ~~below~~) shall be:

$$TD \geq 0.4 \text{ mm}$$

##### 2.4. Homogeneity of the surface

Every practical effort shall be made to ensure that the surface is made to be as homogeneous as possible within the test area. This includes the texture and

<sup>1</sup> ISO 10844:1994

voids content, but it should also be observed that if the rolling process results in more effective rolling at some places than at others, the texture may be different and unevenness causing bumps may also occur.

#### 2.5. Period of testing

In order to check whether the surface continues to conform to the texture and voids content or sound absorption requirements stipulated in this standard, periodic testing of the surface shall be done at the following intervals:

(a) For residual voids content or sound absorption:

when the surface is new; if the surface meets the requirements when new, no further periodical testing is required. ~~If it does not meet the requirement when it is new, it may do so later because surfaces tend to become clogged and compacted with time.~~

(b) For texture depth (TD):

when the surface is new; when the noise testing starts (NB Note: not before ~~four~~ 4 weeks after laying); then every 12 months.

### 3. Test surface design

#### 3.1. Area

When designing the test track layout it is important to ensure that, as a minimum requirement, the area traversed by the vehicles running through the test strip is covered with the specified test material with suitable margins for safe and practical driving. This will require the width of the track to be at least 3 m and the length of the track to extend beyond lines AA and BB by at least 10 m at either end. Figure 1 shows a plan of a suitable test site and indicates the minimum area which shall be machine laid and machine compacted with the specified test surface material. According to Annex 3, paragraph 3.1.1.1., measurements have to be made on each side of the vehicle. This can be done either by measuring with two microphone locations (one on each side of the track) and driving in one direction, or measuring with a microphone only on one side of the track but driving the vehicle in two directions. If the ~~former~~ **latter** method is used, then there are no surface requirements on that side of the track where there is no microphone.

Figure 1  
**Minimum requirement for test surface area. The shaded part is the "Test Area".**

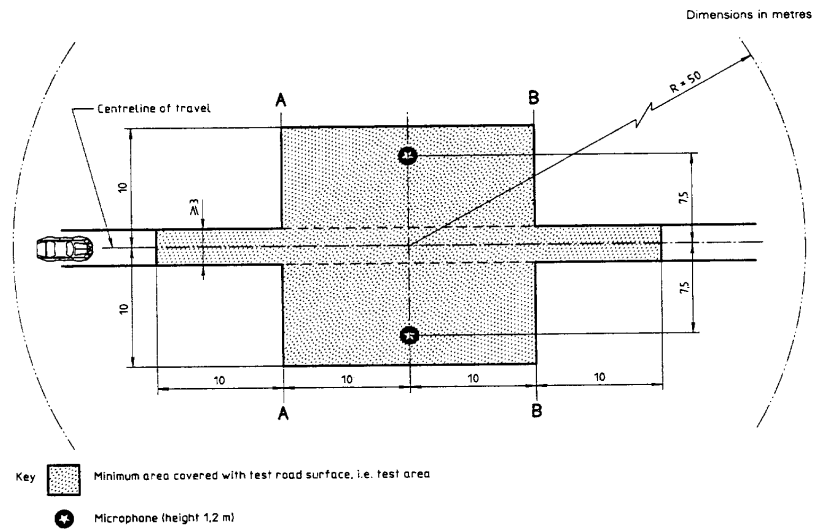

NOTE — There shall be no large acoustically reflective objects within this radius.

### 3.2. Design and preparation of the surface

3.2.1. Basic design requirements; the test surface shall meet four design requirements:

3.2.1.1. It shall be a dense asphaltic concrete;

3.2.1.2. The maximum chipping size shall be 8 mm (tolerances allow from 6.3 to 10 mm);

3.2.1.3. The thickness of the wearing course shall be  $\geq 30$  mm;

3.2.1.4. The binder shall be a straight penetration grade bitumen without modification.

### 3.2.2. Design guidelines

As a guide to the surface constructor, an aggregate grading curve which will give desired characteristics is shown in Figure 2. In addition, Table 1 gives some guidelines for obtaining the desired texture and durability. The grading curve fits the following formula:

$$P (\% \text{ passing}) = 100 \cdot (d/d_{\max})^{1/2}$$

where:

- $d$  = square mesh sieve size, in mm
- $d_{\max}$  = 8 mm for the mean curve
- $d_{\max}$  = 10 mm for the lower tolerance curve
- $d_{\max}$  = 6.3 mm for the upper tolerance curve

Figure 2  
Grading curve of the aggregate in the asphaltic mix with tolerances.

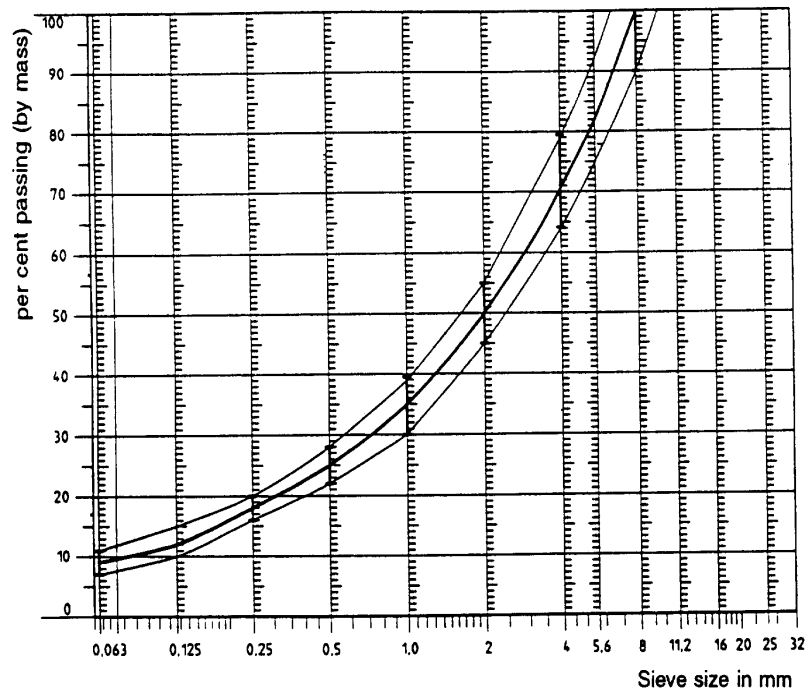

In addition to the above, the following recommendations are given:

- (a) The sand fraction ( $0.063 \text{ mm} < \text{square mesh sieve size} < 2 \text{ mm}$ ) shall include no more than 55 % **per cent** natural sand and at least 45 % **per cent** crushed sand;
- (b) The base and sub-base shall ensure a good stability and evenness, according to best road construction practice;
- (c) The chippings shall be crushed (100 % **per cent** crushed faces) and of a material with a high resistance to crushing;
- (d) The chippings used in the mix shall be washed;
- (e) No extra chippings shall be added onto the surface;
- (f) The binder hardness expressed as PEN value shall be 40-60, 60-80 or even 80-100 depending on the climatic conditions of the country. The rule is that as hard a binder as possible shall be used, provided this is consistent with common practice;
- (g) The temperature of the mix before rolling shall be chosen so as to achieve by subsequent rolling the required voids content. In order to increase the probability of satisfying the specifications of paragraphs 2.1. to 2.4. ~~above~~, the compactness shall be studied not only by an appropriate choice of mixing temperature, but also by an appropriate number of passings and by the choice of compacting vehicle.



Table 1  
Design guidelines

<i>Quantity</i>	<i>Target values</i>		<i>Tolerances</i>
	<i>by total mass of mix</i>	<i>by mass of the aggregate</i>	
Mass of stones, square mesh sieve (SM) > 2 mm	47.6 %	50.5 %	±5
Mass of sand 0.063 < SM < 2 mm	38.0 %	40.2 %	±5
Mass of filler SM < 0.063 mm	8.8 %	9.3 %	±2
Mass of binder (bitumen)	5.8 %	N.A.	±0.5
Max. chipping size	8 mm		6.3 – 10
Binder hardness	(see paragraph 3.2.2. (f))		–
Polished stone value (PSV)	> 50		–
Compactness, relative to Marshall compactness	98 %		–

## 4. Test method

### 4.1. Measurement of the residual voids content

For the purpose of this measurement, cores have to be taken from the track in at least four different positions which are equally distributed in the test area between lines AA and BB (see Figure 1). In order to avoid inhomogeneity and unevenness in the wheel tracks, cores should not be taken in wheel tracks themselves, but close to them. Two cores (minimum) should be taken close to the wheel tracks and one core (minimum) should be taken approximately midway between the wheel tracks and each microphone location.

If there is a suspicion that the condition of homogeneity is not met (see paragraph 2.4.), cores shall be taken from more locations within the test area. The residual voids content has to be determined for each core, then the average value from all cores shall be calculated and compared with the requirement of paragraph 2.1. In addition, no single core shall have a voids value which is higher than 10% **per cent**. The test surface constructor is reminded of the problem which may arise when the test area is heated by pipes or electrical wires and cores ~~must~~ **shall** be taken from this area. Such installations ~~must~~ **shall** be carefully planned with respect to future core drilling locations. It is recommended that a few locations of size approximately 200 x 300 mm should be left where there are no wires/pipes or where the latter are located deep enough in order not to be damaged by cores taken from the surface layer.

### 4.2. Sound absorption coefficient

The sound absorption coefficient (normal incidence) shall be measured by the impedance tube method using the procedure specified in ISO/DIS 10 534: **1994** "Acoustics - Determination of sound absorption coefficient and impedance by a tube method".

Regarding test specimens, the same requirements shall be followed as regarding the residual voids content (see paragraph 4.1).

The sound absorption shall be measured in the range between 400 Hz and 800 Hz and in the range between 800 Hz and 1,600 Hz (at least at the centre frequencies of third octave bands) and the maximum values shall be identified for both of these frequency ranges.

Then these values, for all test cores, shall be averaged to constitute the final result.

4.3. Volumetric macrotexture measurement

For the purpose of this standard, texture depth measurements shall be made on at least 10 positions evenly spaced along the wheel tracks of the test strip and the average value taken to compare with the specified minimum texture depth. For the description of the procedure see standard ISO 10844:1994.

## 5. Stability in time and maintenance

5.1. Age influence

In common with any other surfaces, it is expected that the tyre/road noise level measured on the test surface may increase slightly during the first 6-12 months after construction.

The surface will achieve its required characteristics not earlier than four weeks after construction. ~~The influence of age on the noise from trucks is generally less than on noise from cars.~~

The stability over time is determined mainly by the polishing and compaction by vehicles driving on the surface. It shall be periodically checked as stated in paragraph 2.5.

5.2. Maintenance of the surface

Loose debris or dust which could significantly reduce the effective texture depth ~~must~~ **shall** be removed from the surface. In countries with winter climates, salt is sometimes used for de-icing. Salt may alter the surface temporarily or even permanently in such a way as to increase noise, and is therefore not recommended.

5.3. Repaving the test area

If it is necessary to repave the test track, it is usually unnecessary to repave more than the test strip (of 3 m width in Figure 1) where vehicles are driving, provided the test area outside the strip met the requirement of residual voids content or sound absorption when it was measured.

## 6. Documentation of the test surface and of tests performed on it

6.1. Documentation of the test surface

The following data shall be given in a document describing the test surface:

6.1.1. The location of the test track.

6.1.2. Type of binder, binder hardness, type of aggregate, maximum theoretical density of the concrete ( $D_R$ ), thickness of the wearing course and grading curve determined from cores from the test track.

6.1.3. Method of compaction (e.g. type of roller, roller mass, number of passes).

- 6.1.4. Temperature of the mix, temperature of the ambient air and wind speed during laying of the surface.
- 6.1.5. Date when the surface was laid and name of the contractor.
- 6.1.6. All test results or at least the latest test result, including:
  - 6.1.6.1. The residual voids content of each core;
  - 6.1.6.2. The locations in the test area from where the cores for voids measurements have been taken;
  - 6.1.6.3. The sound absorption coefficient of each core (if measured). Specify the results both for each core and each frequency range, as well as the overall average;
  - 6.1.6.4. The locations in the test area from where the cores for absorption measurement have been taken;
  - 6.1.6.5. Texture depth, including the number of tests and standard deviation;
  - 6.1.6.6. The institution responsible for **the** tests according to paragraphs 6.1.6.1. and 6.1.6.2. and the type of equipment used;
  - 6.1.6.7. Date of the test(s) and date when the cores were taken from the test track.
- 6.2. Documentation of vehicle noise tests conducted on the surface  
 In the document describing the vehicle noise test(s) it should be stated whether all the requirements of this standard were fulfilled or not. Reference shall be given to a document according to paragraph 6.1. describing the results which verify this.

## II. Justification

1. These proposed amendments to UN Regulation No. 9 comprise a consolidate version of the UN Regulation and align the test methods to those introduced into UN Regulation No. 41.
2. This revision incorporates:
  - Amendment 1 to the 01 series of amendments, Addendum 62 - Date of entry into force: 8 March 1999.
  - Corrigendum 1 to Amendment 1 to the 01 series of amendments, Addendum 62 - Date of entry into force: 6 August 1999.
  - Corrigendum 2 to Amendment 1 to the 01 series of amendments, Addendum 62 - Date of entry into force: 5 June 2001.
  - Amendment 2, Supplement 1 to the 01 series of amendments, Addendum 62 - Date of entry into force: 10 October 2006.