



Economic and Social Council

Distr.: General
24 August 2012

Original: English

Economic Commission for Europe

Inland Transport Committee

World Forum for Harmonization of Vehicle Regulations

158th session

Geneva, 13-16 November 2012

Item 4.8.10 of the provisional agenda

1958 Agreement – Consideration of draft amendments to existing Regulations submitted by GRSG

Proposal for the 01 series of amendments to Regulation No. 125 (Forward field of vision of drivers)

Submitted by the Working Party on General Safety Provisions*

The text reproduced below was adopted by the Working Party on General Safety Provisions (GRSG) at its 102nd session. It is based on ECE/TRANS/WP.29/GRSG/2012/10, as reproduced in Annex IX to the report (ECE/TRANS7WP.29/GRSG/81, para. 28). It is submitted to the World Forum for Harmonization of Vehicle Regulations (WP.29) and to the Administrative Committee AC.1 for consideration.

* In accordance with the programme of work of the Inland Transport Committee for 2010–2014 (ECE/TRANS/208, para. 106 and ECE/TRANS/2010/8, programme activity 02.4), the World Forum will develop, harmonize and update regulations in order to enhance the performance of vehicles. The present document is submitted in conformity with that mandate.

The table of contents, amend to read:

"Regulation

1. Scope

...

11. Names and addresses of Technical Services responsible for conducting approval tests, and of Type Approval Authority

12. Transitional Provisions"

The text of the Regulation,

Paragraph 4.2., amend to read:

"4.2. An approval number shall be assigned to each type approved. Its first two digits (at present 01 for the Regulation in its current form) shall indicate the series of amendments incorporating"

Insert a new paragraph 5.1.4., including new figures 1 and 2, to read:

"5.1.4. In the case where the height of V2 above the ground exceeds 1,650 mm, the following requirement shall be met:

A 1,200 mm tall cylindrical object with a diameter of 300 mm that is situated inside the space bounded by a vertical plane located 2,000 mm in front of the vehicle, a vertical plane located 2,300 mm in front of the vehicle, a vertical plane located 400 mm from the driver's side of the vehicle, and a vertical plane located 600 mm from the opposite side of the vehicle shall be at least partially visible when viewed directly from V2 (see figure 1), regardless of where the object is within that space, unless it is invisible due to a blind spot(s) created by the A pillars, windscreen wipers, or steering wheel.

If the driver's seat is located in the central driving position of the vehicle, the 1,200 mm tall cylindrical object shall be situated inside the space bounded by a vertical plane located 2,000 mm in front of the vehicle, a vertical plane located 2,300 mm in front of the vehicle, a vertical plane located 500 mm from the side of the vehicle (see figure 2).

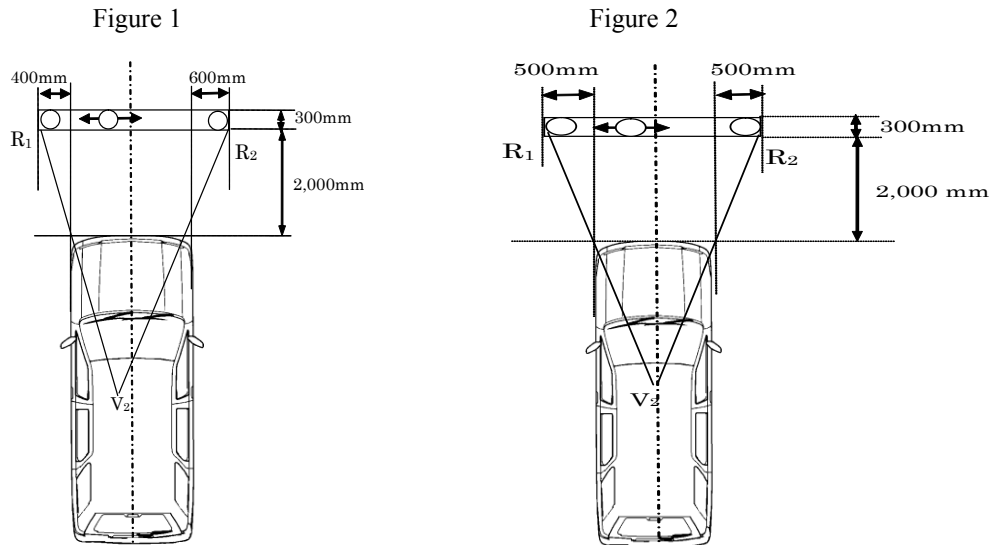

Insert new paragraphs 12.1. to 12.5., to read:

- "12. Transitional Provisions
- 12.1. As from the official date of entry into force of the 01 series of amendments, no Contracting Party applying this Regulation shall refuse to grant approval under this Regulation as amended by the 01 series of amendments.
- 12.2. As from 24 months after the date of entry into force of the 01 series of amendments to this Regulation, Contracting Parties applying this Regulation shall grant approvals only if the vehicle type to be approved meets the requirements of this Regulation as amended by the 01 series of amendments.
- 12.3. Contracting Parties applying this Regulation shall not refuse to grant extensions of approvals for existing types which have been granted according to the original version of this Regulation.
- 12.4. Even after the entry into force of the 01 series of amendments to this Regulation, type approvals of the vehicles to the original version of this Regulation shall remain valid. Contracting Parties applying this Regulation shall continue to accept them.
- 12.5. Notwithstanding the transitional provisions above, Contracting Parties whose application of this Regulation comes into force after the date of entry into force of the 01 series of amendments are not obliged to accept approvals which were granted in accordance with the original version of this Regulation."

Annex 2, amend to read:

"Annex 2

Arrangements of approval marks

(See paragraphs 4.4. to 4.4.2. of this Regulation)

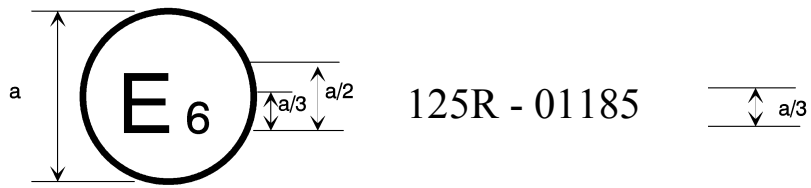

a = 8 mm min

The above approval mark affixed to a vehicle shows that the vehicle type concerned has been approved in Belgium (E6) with regard to the driver's forward field of vision pursuant to Regulation No. 125. The first two digits of the approval number indicate that the approval was granted in accordance with the requirements of Regulation No. 125 as amended by the 01 series of amendments."
