

**Amendments agreed to ECE/TRANS/WP.29/GRSP/2010/38
during the 48th session of GRSP**

**Draft new Regulation on uniform provisions concerning the
approval of enhanced Child Restraint Systems used onboard
of motor vehicles**

Contents

	<i>Page</i>
1. Scope	4
2. Definitions.....	4
3. Application for approval	11
4. Markings	11
5. Approval.....	13
6. General specifications	15
7. Tests	35
8. Test reports of type approval and of production qualification	50
9. Production qualification	50
10. Conformity of production and routine tests.....	51
11. Modification and extension of approval of a Child Restraint System	52
12. Penalties for non-conformity of production	52
13. Production definitely discontinued.....	52
14. Information for users	53
15. Transitional Provisions.....	54
16. Names and addresses of technical services responsible for conducting approval tests and of administrative departments	55
 Annexes	
1. Communication	56
2. Arrangements of the approval mark	58
3. Arrangement of apparatus for dust resistance test.....	59
4. Corrosion Test.....	60
5. Abrasion and microslip test.....	62
6. Description of Trolley	65

Appendix 1	71
Appendix 2 — Arrangement and use of anchorages on the test trolley	75
Appendix 3 — Lateral impact and door panel description	76
7. Curve of trolleys deceleration or acceleration, as function of time	77
Appendix 1 — Frontal impact	78
Appendix 2 — Rear impact	79
Appendix 3 — Lateral impact	80
Appendix 4	82
8. Description of manikins	84
9. Frontal impact test against a barrier	89
10. Rear impact test procedure	91
12. Type approval scheme (flow chart ISO 9002:2000)	94
13. Control of conformity of production	96
14. Test of energy absorbing material	100
15. Method of defining head impact area of devices with headrests and for rearward-facing devices defining the minimum size of side wings	102
16. Description of conditioning of adjusters mounted directly on child restraints	103
17. Typical buckle strength test device	104
18. Dynamic crash test installation	105
19. Geometrical dimensions of  -Size Child Restraint Systems	106

Deleted: . 11. . Lateral impact test procedure . . 93*

1. Scope

This Regulation applies (in its Phase 1) to Integral Universal ISOFIX Child Restraint Systems ($\text{\textcircled{1}}$ -Size) for child occupants of power driven vehicles.

2. Definitions

For the purposes of this Regulation,

- 2.1. “*Child Restraint System*” [CRS] means a device offering the child occupant the possibility to sit on, to sit in and/or to lay in. It is so designed as to diminish the risk of injury to the wearer, in the event of a collision or of abrupt deceleration of the vehicle, by limiting the mobility of the child’s body.
- 2.2. “*Child restraint type*” means Child Restraint System which does not differ in such essential respects as:
the category and orientation (as defined in paragraph 2.11.) in which the restraint is intended to be used;
the geometry of the Child Restraint System.
- 2.3. “ $\text{\textcircled{1}}$ -Size” (Integral Universal ISOFIX Child Restraint Systems) is a category indication for a Child Restraint System meaning it is for use in all $\text{\textcircled{1}}$ -Size ready vehicles, not necessarily on all vehicle positions, approved according to Regulation No. 16 including its suitability for such a category of Child Restraint System.
- 2.4. “*Integral*” is a class indication for the retention of the child occupant in the Child Restraint System, meaning that the child is restrained only by means that make part of the Child Restraint System (strap harness, shield, etc.), not by means directly connected to the vehicle.
- 2.5. “*ISOFIX*” is a **system** for the retention of the child occupant in the child restraint system, meaning that the child has to be restrained not only by means making part of this child restraint system but the retention of the child is dependent upon other means directly connected to the vehicle.
- 2.6. “*ISOFIX*” is an indication for the system of connection of a Child Restraint System to vehicles. It is based on two vehicle anchorages and two corresponding attachments on the Child Restraint System **and a means to limit the pitch rotation of the Child Restraint System.**
- 2.6. “**NON-ISOFIX**” is an indication for the system of connection of a child restraint system to vehicles meaning that for its fixation no use is made of the ISOFIX anchorage. “*ISOFIX Universal*” is a **system** for the connection of a Child Restraint System to vehicles. It is based on two vehicle anchorages and two corresponding attachments on the Child Restraint System in conjunction with an anti-rotation device meant, **comprising a top-tether or support-leg**, to limit the pitch rotation of the Child Restraint System, attached to, or supported by, the corresponding vehicle **structure to limit this pitch rotation.** All three vehicle anchorages and the vehicle **contact** area are to be approved according Regulation No. 14.

- 2.7. “*Specific vehicle ISOFIX or ‘built in’*” is an indication for the system of connection of a Child Restraint System to specific vehicle types. **All vehicle anchorages are to be approved according to Regulation No. 14. It is also an indication for Child Restraint Systems including dashboard as a vehicle contact zone.**
- 2.8. “Size” is a stature indication, for a Child Restraint System ~~providing information for which range of child occupants it is meant. It is primarily, based on standing height of children in order to facilitate proper use, but also limited by a maximum mass to provide manufacturers information that is related to expect maximum loads. Child restraint systems may cover any size range provided that all requirements are fulfilled.~~
- 2.9. “*Orientation*” is the indication that a Child Restraint System can be used forward-facing and/or rearward-facing, the following distinction is made:
- (a) forward-facing means facing in the normal direction of travel of the vehicle;
 - (b) rearward-facing means facing in the direction opposite to the normal direction of travel of the vehicle;
 - (c) lateral-facing means facing perpendicular to the normal direction of travel of the vehicle.
- 2.10. “*Special Needs Restraint*” is a Child Restraint System designed for children who have special needs as a result of either a physical or mental disability; this device may in particular permit additional restraining devices for any part of the child, but it must contain as a minimum a primary means of restraint which complies with the requirements of this Regulation.
- 2.11. “*ISOFIX anchorage system*” means a system made up of 2 ISOFIX low anchorages fulfilling the requirements of Regulation No. 14 which is designed for attaching an ISOFIX Child Restraint System in conjunction with an anti-rotation device.
- 2.11.1. “*ISOFIX low anchorage*” means one 6 mm diameter rigid round horizontal bar, extending from vehicle or seat structure to accept and restrain an ISOFIX Child Restraint System with ISOFIX attachments.
- 2.11.2. “*ISOFIX attachment*” means one of the two connections, fulfilling the requirement of paragraph [6.3.2.] of this Regulation, extending from the ISOFIX Child Restraint System structure, and compatible with an ISOFIX low anchorage.
- 2.12. “*Anti-rotation device*” means a device intended to limit the rotation of the Child Restraint System during an impact consisting of:
- (a) a top-tether strap; or
 - (b) a support-leg.

Meeting the requirements of this Regulation and fitted to ISOFIX anchorages system and ISOFIX top tether anchorages ~~or~~ vehicle **contact** area meeting the requirements of Regulation No. 14.

“Anti-rotation device” for a specific vehicle ISOFIX Child Restraint System consists of either a top tether or a support-leg approved according to this regulation as mentioned above or any other means intended to limit the rotation of the restraint during a frontal impact.

- 2.13. “*ISOFIX top tether strap*” means a webbing strap (or equivalent) which extends from the top of an ISOFIX Child Restraint System to the ISOFIX top tether anchorage, and which is equipped with an adjustment device, a tension-relieving device, and an ISOFIX top tether connector.
- 2.13.1. “*ISOFIX top tether anchorage*” means a feature fulfilling the requirements of Regulation No. 14, such as a bar, located in a defined zone, designed to accept an ISOFIX top tether connector and transfer its restraint force to the vehicle structure.
- 2.13.2. “*ISOFIX top tether connector*” means a device intended to be attached to an ISOFIX top tether anchorage.
- 2.13.3. “*ISOFIX top tether hook*” means an ISOFIX top tether connector typically used to attach an ISOFIX top tether strap to an ISOFIX top tether anchorage as defined in figure 3 of Regulation No. 14.
- 2.13.4. “*ISOFIX top tether attachment*” is a device to secure the ISOFIX top tether strap to the ISOFIX Child Restraint System.
- 2.13.5. “*Tension relieving device*” means a system which allows to release the device that adjusts and maintains the tension in the ISOFIX top tether strap.
- 2.13.6. “*Support-leg*” means a permanent **part** to a Child Restraint System creating a compressive load path between the Child Restraint System and a vehicle structure in order to **provide an anti-rotation device for the Child Restraint System** during deceleration ~~a support-leg must have a pushing surface with a minimum size. A support-leg is composed of a foot and a leg and is adjustable length with a minimum and a maximum size.~~
- 2.13.7. “*Support-leg foot*” means **the surface of the support-leg of the Child Restraint System intended (by design) to be in contact with the vehicle floor and intended to transmit — a part of — the Child Restraint System loading during a frontal impact to the vehicle body structure.**
- 2.13.8. “*Support-leg foot contact surface*” means **the surface of the support-leg foot physically in contact with the vehicle floor, designed to spread the loads on the vehicle floor.**
- 2.13.9. “*Support-leg contact volume*” means **the volume defined by X, Y and Z dimensions. The support-leg must stay within the X and Z dimensions. The support-leg is only able to reach positions outside of this volume in Z direction.**
- 2.13.10. “*Support-leg adjustment capability*” means **the adjustment of the support-leg foot in dimensions X and Y and Z that a Child Restraint System with support-leg must have.**
- 2.13.11. “*Support-leg centre axis*” means **the natural axis in Z or close to Z, which forms the centreline of the support-leg. The support-leg centre axis of a split support-leg can therefore lie outside the physical support-leg.**

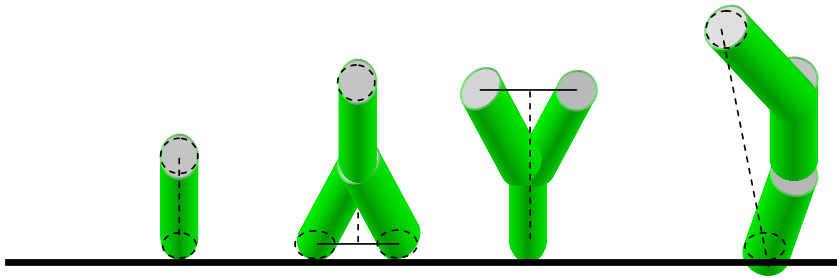

- 2.13.12. “*Vehicle contact volume*” means a volume defined in (X, Y, Z) in relation to the ISOFIX anchor points, where the reception area must lie fully inside.
- 2.13.13. “*Vehicle contact area*” means the part of the car floor intended to withstand the compression forces introduced by a CRS support-leg foot.
- 2.13.14. “*CRF pitch angle*” is the angle between the bottom surface of the fixture “ISO/F2 (B) as defined in Regulation No. 16 (annex 17, appendix 2, figure 2) and the horizontal Z plane of the vehicle as defined in Regulation No. 14 (annex 4, appendix 2), with the fixture installed in the vehicle as defined in Regulation No. 16 (annex 17, appendix 2).

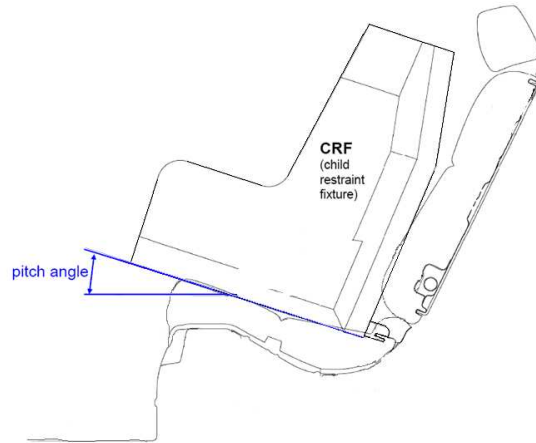

- 2.13.15. “*SFAD SL*” means the **Static Force Application Device** as defined in Regulation No. 14, annex 9, to be modified with the inclusion of a support-leg.
- 2.14. “*Vehicle seat fixture (VSF)*” means a fixture, according to ISOFIX size classes whose dimensions are given in figures 1 to 6 of Annex 17 Appendix 2 of Regulation No. 16, used by a Child Restraint System manufacturer to determine the appropriate dimensions of an ISOFIX Child Restraint System and the location of its ISOFIX attachments.
- 2.15. “*Child-safety chair*” means a Child Restraint System incorporating a chair in which the child is held.

- 2.16. “*Chair*” means a structure which is a constituent part of the Child Restraint System and is intended to accommodate a child in a seated position.
- 2.17. “*Chair support*” means that part of a Child Restraint System by which the chair can be raised.
- 2.18. “*Belt*” means a child restraint comprising a combination of straps with a securing buckle, adjusting devices and attachments.
- 2.19. “*Harness belt*” means a belt assembly comprising a lap belt, shoulder restraints and a crotch strap.
- 2.20. “*Y-shaped belt*” means a belt where the combination of straps is formed by a strap to be guided between the child’s legs and a strap for each shoulder.
- 2.21. “*Carry cot*” means a restraint system intended to accommodate and restrain the child in a supine or prone position with the child’s spine perpendicular to the median longitudinal plane of the vehicle. It is so designed as to distribute the restraining forces over the child’s head and body excluding its limbs in the event of a collision.
- 2.22. “*Carry-cot restraint*” means a device used to restrain a carry-cot to the structure of the vehicle.
- 2.23. “*Infant carrier*” means a restraint system intended to accommodate the child in a rearward-facing semi-recumbent position. It is so designed as to distribute the restraining forces over the child’s head and body excluding its limbs in the event of the frontal collision.
- 2.24. “*Child support*” means that part of a Child Restraint System by which the child can be raised within the Child Restraint System.
- 2.25. “*Impact shield*” means a device secured in front of the child and designed to distribute the restraining forces over the greater part of the height of the child’s body in the event of a frontal impact.
- 2.26. “*Strap*” means a flexible component designed to transmit forces.
- 2.27. “*Lap strap*” means a strap which, either in the form of a complete belt or in the form of a component of such a belt passes across the front of, and restrains, the child’s pelvic region.
- 2.28. “*Shoulder strap*” means that part of a belt which restrains the child’s upper torso.
- 2.29. “*Crotch strap*” means a strap (or divided straps, where two or more pieces of webbing make it) attached to the Child Restraint System and the lap strap and is so positioned as to pass between the child’s thighs; it is designed to prevent the child sliding under the lap belt in normal use and prevent the lap belt moving up off the pelvis in an impact.
- 2.30. “*Child-restraining strap*” means a strap which is a constituent part of the belt (harness) and restrains only the body of the child.
- 2.31. “*Buckle*” means a quick release device which enables the child to be held by the restraint or the restraint by the structure of the car and can be quickly opened. The buckle may incorporate the adjusting device.
- 2.32. “*Enclosed buckle release button*”, a buckle release button such that it must not be possible to release the buckle using a sphere having a diameter of 40 mm.

- 2.33. “*Non-enclosed buckle release button*”, a buckle release button such that it must be possible to release the buckle using a sphere having a diameter of 40 mm.
- 2.34. “*Adjusting device*” means a device enabling the belt or its attachments to be adjusted to the physique of the wearer. The adjusting device may either be part of the buckle or be a retractor or any other part of the belt.
- 2.35. “*Quick adjuster*” means an adjusting device which can be operated by one hand in one smooth movement.
- 2.36. “*Adjuster mounted directly on Child Restraint System*” means an adjuster for the harness belt which is directly mounted on the Child Restraint System, as opposed to being directly supported by the strap that it is designed to adjust.
- 2.37. “*Energy absorber*” means a device which is designed to dissipate energy independently of or jointly with the strap and forms part of a Child Restraint System.
- 2.38. “*Retractor*” means a device designed to accommodate a part or the whole of the strap of a Child Restraint System. The term covers the following devices:
- 2.38.1. “*Automatically-locking retractor*”, a retractor which allows extraction of the desired length of a strap and, when the buckle is fastened, automatically adjusts the strap to the wearer's physique, further extraction of the strap without voluntary intervention by the wearer being prevented.
- 2.38.2. “*Emergency-locking retractor*”, a retractor which does not restrict the strap wearer's freedom of movement in normal driving conditions. Such a device has length-adjusting devices which automatically adjust the strap to the wearer's physique, and a locking mechanism actuated in an emergency by:
- 2.38.2.1. deceleration of the vehicle, extraction of the strap from the retractor, or any other automatic means (single sensitivity);
- 2.38.2.2. a combination of any of these means (multiple sensitivity).
- 2.39. “*Inclined position*” means a special position of the chair which allows the child to recline.
- 2.40. “*Lying down/supine/prone position*” means a position where at least the child's head and body excluding its limbs are on a horizontal surface when at rest in the restraint.
- 2.41. “*Vehicle seat*” means a structure, which may or may not be integral with the vehicle structure, complete with trim and intended to seat one adult person. In this respect:
- “*Group of vehicle seats*” means either a bench seat or a plurality of seats which are separate but side by side (i.e. so fixed that the front anchorages of one seat are in line with the front or rear anchorages of another seat or on a line passing between those anchorages), each seat accommodating one or more seated adult persons.
- “*Vehicle bench seat*” means a structure complete with trim and intended to seat more than one adult person.
- “*Vehicle front seats*” means the group of seats situated foremost in the passenger compartment, i.e. having no other seat directly in front of them.

- “*Vehicle rear seats*” are fixed, forward-facing seats situated behind another group of vehicle seats.
- 2.42. “*Seat type*” means a category of adult seats which do not differ in such essential respects as the shape, dimensions and materials of the seat structure, the types and dimensions of the seat-lock adjustment and locking systems, and the type and dimensions of the adult safety-belt anchorage on the seat, of the seat anchorage, and of the affected parts of the vehicle structure.
- 2.43. “*Adjustment system*” means the complete device by which the vehicle seat or its parts can be adjusted to suit the physique of the seat’s adult occupant; this device may, in particular, permit longitudinal displacement, and/or vertical displacement, and/or angular displacement.
- 2.44. “*Vehicle seat anchorage*” means the system, including the affected parts of the vehicle structure, by which the adult seat as a whole is secured to the vehicle structure.
- 2.45. “*Displacement system*” means a device enabling the adult seat or one of its parts to be displaced angularly or longitudinally, without a fixed intermediate position, to facilitate the entry and exit of passengers and the loading and unloading of objects.
- 2.46. “*Locking system*” means a device ensuring that the adult seat and its parts are maintained in the position of use.
- 2.47. “*Seat bight*” means the area close to the intersection of the surfaces of the vehicle seat cushion and the **seat-back**.
- 2.48. “*ISOFIX position*” means a system which allows to install:
- (a) either an universal ISOFIX Child Restraint System as defined in Regulation No. 44;
 - (b) or a specific vehicle or a “built in” ISOFIX Child Restraint System as defined in Regulation No. 44.
- 2.49. “*Type approval test*”, means a test to determine the extent to which a Child Restraint System type submitted for approval is capable of satisfying the requirements.
- 2.50. “*Production qualification test (qualification of production test)*”, means a test to determine whether the manufacturer is able to produce a Child Restraint System in conformity with the Child Restraint Systems submitted for type approval.
- 2.51. “*Routine testing*” (or conformity of production testing), means the testing of a number of restraint systems selected from a single batch to verify the extent to which they satisfy the requirements.
- 2.52. “***Shoulder strap positioner***” means a device intended to maintain in normal transit conditions the appropriate shoulder strap position on the child’s torso by connecting the shoulder straps to one another in a releasable manner.

3. Application for Approval

- 3.1. The application for approval of a type of Child Restraint System shall be submitted by the holder of the trade mark or by his duly accredited representative, and follow the type approval scheme described in Annex 12.
- 3.2. The application for approval, relating to each type of Child Restraint System, shall be accompanied by:
 - 3.2.1. A technical description of the Child Restraint System, specifying the straps and other materials used, **predicted and reproducible behaviour of load limiting devices**, and accompanied by drawings of the parts making up the Child Restraint System and in the case of retractors, installation instructions for these retractors and their sensing devices, declaration on toxicity (paragraph 6.1.3.) and flammability (paragraph 6.1.4.), the drawings must show the position intended for the approval number and additional symbol(s) in relation to the circle of the approval mark;
 - 3.2.2. samples of the Child Restraint System requested by the Technical Service Responsible for conducting the test;
 - 3.2.3. a 10-metre length of each type of strap used in the Child Restraint System; and
 - 3.2.4. instructions and details of packaging in accordance with paragraph 14 below.
- 3.3. The Approval Authority of a Contracting Party must verify, before granting type approval the existence of satisfactory arrangements and procedures for ensuring effective control so that Child Restraint Systems, equipment or parts when in production conform to the approved type.

4. Markings

- 4.1. The samples of Child Restraint Systems submitted for approval in conformity with the provisions of paragraphs 3.2.2. and 3.2.3. above shall be clearly and indelibly marked with the manufacturer's name, initials or trade mark.
- 4.2. The Child Restraint System, except the strap(s) or harness, shall be marked clearly and indelibly with the year of production.
- 4.3. The orientation of the Child Restraint System relative to the vehicle must be clearly indicated on the product.

The marking defined in this paragraph shall be visible with the Child Restraint System in the vehicle, with the child in the Child Restraint System.
- 4.4. On the visible inner surface (including the side wing beside the child's head) in the approximate area where the child's head rests within the Child Restraint System, rearward facing restraints shall have the following label permanently attached (the text information shown is a minimum).

[This label shall be provided in the language(s) of the country where the device is sold. **To be harmonized with that provided by Regulation No. 94]**

Label minimum size: 60 x 120 mm.

The label shall be stitched to the cover around its entire perimeter and/or permanently bonded to the cover over its entire back surface. Any other form

of attachment that is permanent and not liable to removal from the product or to becoming obscured is acceptable. Flag type labels are specifically prohibited.

If sections of the restraint or any accessories supplied by the Child Restraint System manufacturer are able to obscure the label an additional label is required. One warning label shall be permanently visible in all situations when the restraint is prepared for use in any configuration.

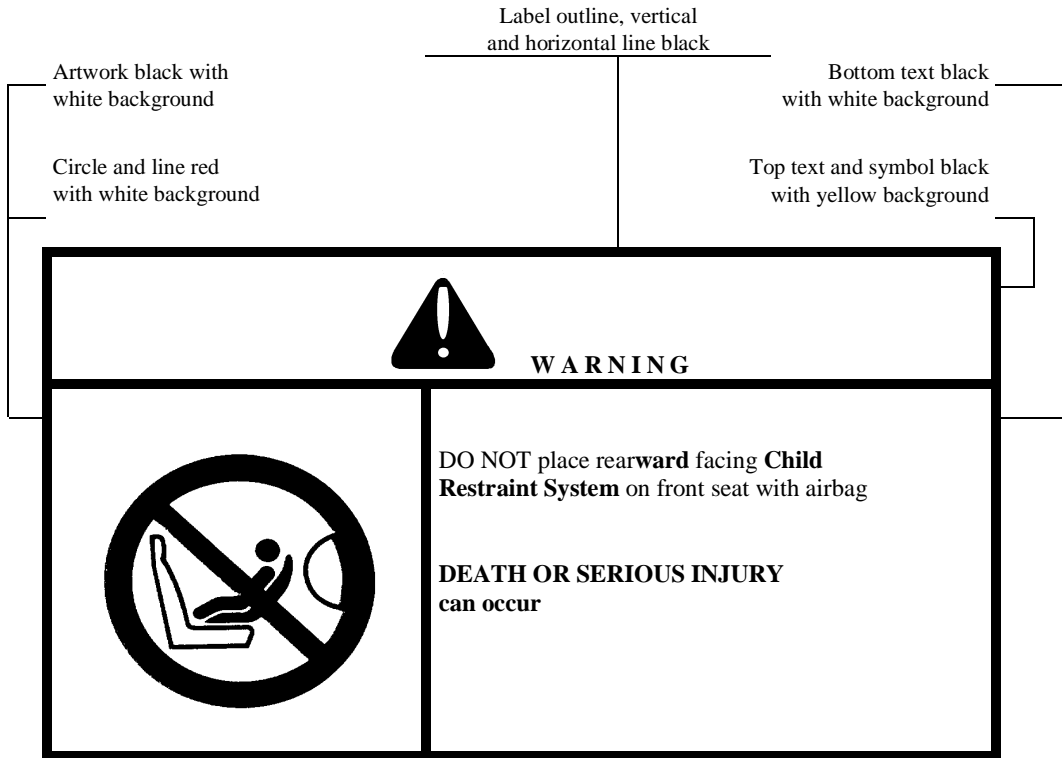

- 4.5. In the case of **Child Restraint Systems** that can be used forward facing and ~~rear-facing~~, include the words:
 “IMPORTANT - DO NOT USE FORWARD FACING BEFORE THE CHILD'S AGE EXCEEDS 15 months (Refer to instructions)”.
- 4.6. **ℓ**-Size Marking.
 The following information must be permanently visible to someone installing the **Child Restraint System** in a vehicle:
- 4.6.1. the **ℓ**-Size logo. As a minimum, a symbol consisting of a circle with a diameter of minimum 13 mm and containing a pictogram, the pictogram shall contrast with the background of the circle. The pictogram shall be clearly visible either by means of contrast colors or by adequate relief if it is molded or embossed;



[-Size]

- 4.6.2. the size range of the **Child Restraint System stature in centimeters**;
- 4.6.3. the maximum occupant mass allowed for the **Child Restraint System mass limit in kilograms**.
- 4.7. The following information may be conveyed by pictograms and/or text. The marking must indicate:
 - (a) The essential relevant steps needed for making the **Child Restraint System** ready for installation. For example, the method of extending the ISOFIX **attachment** must be explained.
 - (b) The position, function, and interpretation of any indicator must be explained.
 - (c) The position and if necessary the routing of top tethers, or other means of limiting **Child Restraint System** rotation requiring action by the user, must be indicated using one of the following symbols as appropriate.

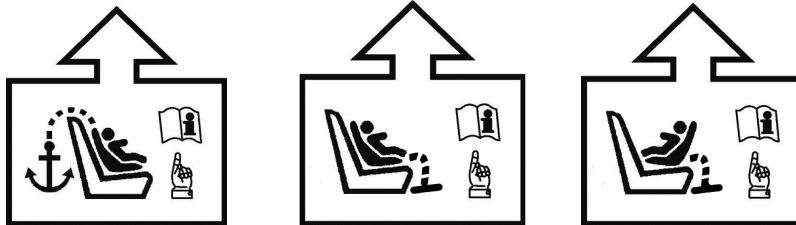

- (d) The adjustment of ISOFIX latches and the top tether, or other means of limiting **Child Restraint System** rotation, requiring action of the user must be indicated.
- (e) The marking must be permanently attached and be visible to a user installing the **Child Restraint System**.
- (f) Where necessary reference should be made to the Child Restraint System user instructions and to the location of that document using the symbol below.



5. Approval

- 5.1. Each sample submitted in conformity with paragraphs 3.2.2. and 3.2.3. above shall meet the specifications set forth in paragraphs 6. to 7. of this Regulation in every respect before approval can be granted.

- 5.2. An approval number shall be assigned to each type approved. Its first two digits (at present 00 corresponding to the 00 series of amendments which entered into force on XXX) shall indicate the series of amendments incorporating the most recent major technical amendments made to the Regulation at the time of issue of the approval. The same Contracting Party shall not assign the same number to another type of Child Restraint System covered by this Regulation.
- 5.3. Notice of approval or of extension or refusal of approval of a Child Restraint System pursuant to this Regulation shall be communicated to the Parties to the Agreement which apply this Regulation by means of a form conforming to the model in Annex 1 to this Regulation.
- 5.4. In addition to the marks prescribed in paragraph 4. above, the following particulars shall be affixed in a suitable space to every Child Restraint System conforming to a type approved under this Regulation:
- 5.4.1. An international approval mark consisting of:
- 5.4.1.1. a circle surrounding the letter “E” followed by the distinguishing number of the country which has granted approval;¹
- 5.4.1.2. an approval number;
- 5.4.2. the following additional symbols:
- 5.4.2.1. the word(s) **Ⓢ**-Size or **integral “specific vehicle” ISOFIX** depending on the category of Child Restraint System;
- 5.4.2.2. the size range for which the Child Restraint System has been designed;
- 5.4.2.3. the symbol “Y”, in the case of a device containing a crotch strap, in conformity with the requirements of this Regulation;
- 5.4.2.4. the symbol “S” in the case of a **Ⓢ**-Size Special Needs Restraint”.
- 5.5. Annex 2 to this Regulation gives an example of the arrangement of the approval mark.

¹ 1 for Germany, 2 for France, 3 for Italy, 4 for the Netherlands, 5 for Sweden, 6 for Belgium, 7 for Hungary, 8 for the Czech Republic, 9 for Spain, 10 for Serbia and Montenegro, 11 for the United Kingdom, 12 for Austria, 13 for Luxembourg, 14 for Switzerland, 15 (vacant), 16 for Norway, 17 for Finland, 18 for Denmark, 19 for Romania, 20 for Poland, 21 for Portugal, 22 for the Russian Federation, 23 for Greece, 24 for Ireland, 25 for Croatia, 26 for Slovenia, 27 for Slovakia, 28 for Belarus, 29 for Estonia, 30 (vacant), 31 for Bosnia and Herzegovina, 32 for Latvia, 33 (vacant), 34 for Bulgaria, 35 (vacant), 36 for Lithuania, 37 for Turkey, 38 (vacant), 39 for Azerbaijan, 40 for The former Yugoslav Republic of Macedonia, 41 (vacant), 42 for the European Union (Approvals are granted by its Member States using their respective ECE symbol), 43 for Japan, 44 (vacant), 45 for Australia, 46 for Ukraine, 47 for South Africa, 48 for New Zealand, 49 for Cyprus, 50 for Malta, 51 for the Republic of Korea, 52 for Malaysia, 53 for Thailand, 54 and 55 (vacant), 56 for Montenegro, 57 (vacant) and 58 for Tunisia. Subsequent numbers shall be assigned to other countries in the chronological order in which they ratify or accede to the Agreement Concerning the Adoption of Uniform Technical Prescriptions for Wheeled Vehicles, Equipment and Parts which can be Fitted and/or be Used on Wheeled Vehicles and the Conditions for Reciprocal Recognition of Approvals Granted on the Basis of these Prescriptions, and the numbers thus assigned shall be communicated by the Secretary-General of the United Nations to the Contracting Parties to the Agreement.

- 5.6. The particulars referred to in paragraph 5.4. above shall be clearly legible and be indelible, and may be affixed either by means of a label or by direct marking. The label or marking shall be resistant to wear.
- 5.7. The labels referred to in paragraph 5.6. above may be issued either by the authority which has granted the approval or, subject to that authority's authorization, by the manufacturer.

6. General Specifications

- 6.1. Positioning and securing on the vehicle.
 - 6.1.1. The use of Child Restraint Systems in the $\text{\textcircled{C}}$ -Size category is permitted in $\text{\textcircled{C}}$ -Size ready vehicles, if the Child Restraint Systems are fitted in conformity with the vehicle manufacturer's instructions.

The use of Child Restraint Systems in the **Integral "Specific Vehicle" ISOFIX** category is permitted ~~Child Restraint Systems~~ in all **ISOFIX** positions and also in the luggage area, if the restraints are fitted in conformity with the vehicle manufacturer's instructions.
 - 6.1.2. According to the category which it belongs to, **see table 1**, the Child Restraint System shall be secured to the vehicle structure or to the vehicle seat structure:
 - 6.1.2.1. For $\text{\textcircled{C}}$ -Size category, by means of two ISOFIX attachments with the addition of an anti-rotation device for forward and rearward-facing Child Restraint System
 - 6.1.2.2. For the "Integral Specific Vehicle ISOFIX" category: by means of the ISOFIX attachments designed by the manufacturer of the Child Restraint System, secured to ISOFIX anchorage system designed by the vehicle manufacturer.

Table 1
Possible configurations for type approval

Orientation	Category	
	$\text{\textcircled{C}}$ -Size CRS	Integral Specific Vehicle ISOFIX CRS
Lateral facing (Carry-cot)	A	A
Rearward facing	A	A
Forward facing (integral)	A	A

With:
CRS: Child Restraint System
A: Applicable

- 6.1.3. ~~The child restraint system manufacturer has to declare in written form that the toxicity of materials used in the manufacture of restraint systems and accessible to the restrained child is in conformity with the relevant parts of~~

CEN Safety of Toys, part 3 (June 1982) . Tests confirming the validity of the declaration may be carried out at the discretion of the test authority.

- ~~6.1.4. The child restraint system manufacturer has to declare in written form that the flammability of materials used to manufacture the restraint system is in conformity with the relevant paragraphs of the ECE Consolidated Resolution on the Construction of Vehicles (R.E.3) (document TRANS/WP.29/78/Rev.1, paragraph 1.20.). Tests confirming the validity of the declaration may be carried out at the discretion of the test authority.~~

~~The child restraint system manufacturer has to declare in written form that the flammability of materials used to manufacture the restraint system is in conformity with the relevant paragraphs of EN 71 Part 2. Tests confirming the validity of the declaration may be carried out at the discretion of the test authority.~~

- 6.1.3. For children under the age of 15 or 18 months only **lateral facing** or rearward facing Child Restraint System must be used. The use of rearward facing Child Restraint System is authorised for any age.

6.2. Configuration of the Child Restraint System

- 6.2.1. The configuration of the Child Restraint System shall be such that:

- 6.2.1.1. the restraint of the child shall give the required protection in any intended position of the Child Restraint System; ~~for “ \oplus Size~~

For “Special Needs Restraints” the primary means of restraint shall give the required protection in any intended position of the Child Restraint System without the use of the additional restraining devices which may be present;

- 6.2.1.2. the child is easily and quickly restrained and removed; in the case of a Child Restraint System in which the child is restrained by means of a harness belt or a Y-shaped belt without a retractor each shoulder restraint and lap strap shall be capable of movement relative to each other during the procedure prescribed in paragraph 6.7.1.4.; in these cases the belt assembly of the Child Restraint System may be designed with two or more connecting parts.

For “Special Needs Restraints” it is recognized that the additional restraining devices will restrict the speed by which a child can be restrained and removed. However, the additional devices shall be designed to release quickly so far as possible;

- 6.2.1.3. if it is possible to change the inclination of the Child Restraint System, this change in inclination shall not require manual readjustment of any other part of the Child Restraint System. A deliberate hand-action is required in order to change the inclination of the Child Restraint System;

- 6.2.1.4. to prevent submarining, either by impact or through restlessness, a crotch strap shall be required on all forward-facing restraints incorporating an integral harness belt system. With the crotch strap attached and in its longest position, if adjustable, it shall not be possible to adjust the lap strap to lie above the pelvis of the **manikin**;

- 6.2.1.5. the assembly shall not subject weak parts of the child’s body (abdomen, crotch, etc.) to excessive stresses. The design shall be such that compression loads shall not be imposed on the crown of the child’s head in the event of a collision;

- 6.2.1.6. all straps of the restraint shall be so placed that they cannot cause discomfort to the wearer in normal use or assume a dangerous configuration. The distance between the shoulder-straps in the vicinity of the neck should be at least the width of the neck of the appropriate manikin.
- 6.2.2. The Child Restraint System shall be so designed and installed as:
 - 6.2.2.1. not to exhibit sharp edges or protrusions liable to cause damage to vehicle-seat covers or to occupant's clothing;
 - 6.2.2.2. to ensure that its rigid parts do not, at **any point** where they are in contact with straps, exhibit sharp edges capable of abrading the straps.
 - 6.2.3. ~~Any components that are not designed to be removable shall not be detached without specific tools. Any components intended to be removable for maintenance or adjustment shall be designed to prevent any risk of incorrect assembly and use. Any separable part shall need special tools to be detached or fixed, as well as the disassembly and assembly processes have to be explained in detail on the user guides. The harness must be adjusted to the child dimension without disassembling it.~~
 - 6.2.4. "Special Needs Restraints" may have additional restraining devices; these shall be designed to avoid any risk of incorrect assembly, and **ensure** that their means of release and mode of operation is immediately obvious to a rescuer in an emergency.
 - 6.2.5. A Child Restraint System may be designed for use in any range of size specified by the manufacturer, provided that it is able to satisfy the requirements laid down in this Regulation.
 - 6.2.6. Child Restraint Systems incorporating inflatable elements shall be so designed that the conditions of use (pressure, temperature, humidity) have no influence on their ability to comply with the requirements of this Regulation.
- 6.3. ~~Size~~ Child Restraint System specifications
 - 6.3.1. **Material**
 - 6.3.1.1. **The Child Restraint System manufacturer must declare in written form that the toxicity of materials used in the manufacture of restraint systems and accessible to the restrained child is in conformity with the relevant parts of EN 71.2009 Part 3 [CEN Safety of Toys, part 3 (June 1982)].² Tests confirming the validity of the declaration may be carried out at the discretion of the test authority.**
 - 6.3.1.2. **The Child Restraint System manufacturer must declare in written form that the flammability of materials used to manufacture the restraint system is in conformity with the relevant paragraphs of EN 71.2009 Part 2. Tests confirming the validity of the declaration may be carried out at the discretion of the test authority.**
 - 6.3.2. General characteristics
 - 6.3.2.1. **Internal geometric characteristics**

Deleted: [Proposal 1:¶
 . Any components, which contribute to the restraint of the child, shall be designed to avoid any risk of incorrect assembly and use. Any separable parts, which contribute to the restraint of the child, shall need special tools to be detached or fixed. Any separable parts, which contribute to the restraint of the child, shall need special tools to be detached or fixed unless it is designed to avoid any risk of incorrect assembly and use

Deleted: Proposal 2:¶

Deleted: so

Deleted: as to avoid any risk

Deleted:]

² The address to obtain the relevant CEN standards is: CEN, 2 rue Bréderode, B.P. 5, B-1000 Brussels, Belgium.

The Technical Service conducting the approval tests shall verify that the internal dimensions of the Child Restraint System conform to the requirements of Annex 19. For any size within the size range declared by the manufacturer the minimum dimensions of shoulder breadth, hip breadth and sitting height must be fulfilled together with the minimum and maximum dimensions of shoulder height.

6.3.2.2. External dimensions

The maximum dimensions for width, height and depth of the Child Restraint System and the locations of the ISOFIX anchorages system with which its attachments must engage are defined for the ISOFIX Child Restraint System manufacturer by the Vehicle Seat Fixture (VSF) as defined in paragraph 2.14. of this Regulation.

- (a) $\textcircled{1}$ -Size Forward facing Child Restraint Systems must fit in ISO/F2x envelope dimensions for a **reduced**-height forward-facing toddler CRS (height **650** mm) ISOFIX SIZE CLASS **B1**.
- (b) $\textcircled{1}$ -Size Rearward facing Child Restraint Systems must fit in ISO/R2 envelope dimensions for a reduced-size rearward-facing toddler CRS ISOFIX SIZE CLASS D.
- (c) “**Integral Specific** vehicle” ISOFIX Child Restraint Systems could fit in any ISO envelope dimensions.

6.3.2.3. Mass

The mass of an **integral ISOFIX Child Restraint System** ($\textcircled{1}$ -Size **Child Restraint System included**) combined with the mass of the **largest** child intended to use the Child Restraint System shall not exceed 33 ~~for 37~~kg.

6.3.3. ISOFIX Attachments

6.3.3.1. Type

ISOFIX Attachments may be according to examples shown in figure 0 (a), or other appropriate designs that are part of a rigid mechanism having provision for adjustment, the nature of which is determined by the ISOFIX Child Restraint System manufacturer.

Figure 0 (a)

Key

- 1 ISOFIX Child Restraint System attachment — example 1
- 2 ISOFIX Child Restraint System attachment — example 2

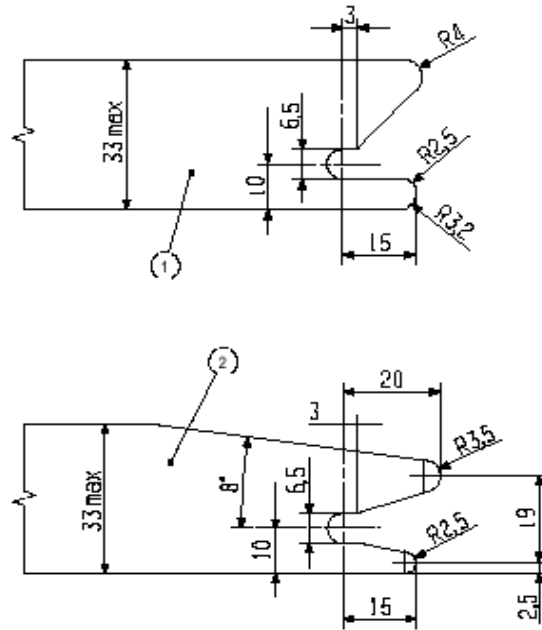

Dimensions in mm

6.3.3.2. Dimensions

Dimensions for the portion of the ISOFIX Child Restraint System attachment that engages the ISOFIX anchorage system must not exceed the maximum dimensions given by the envelope in figure 0 (b).

Figure 0 (b)

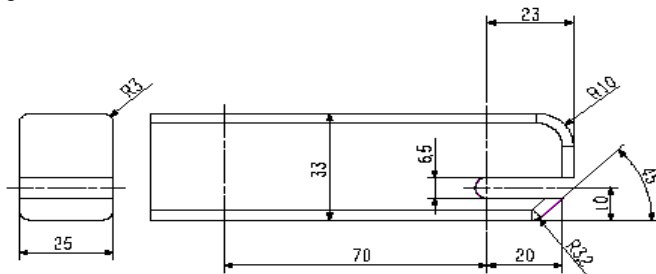

Dimensions in mm

6.3.3.3. Partial latching indication

The ISOFIX Child Restraint System shall incorporate means by which there is a clear indication that both of the ISOFIX attachments are completely latched with the corresponding ISOFIX lower anchorages. The indication means may be audible, tactile or visual or a combination of two or more. In case of visual indication it must be detectable under all normal lighting conditions.

6.3.4. ISOFIX Child Restraint System top tether strap specifications

6.3.4.1. Top tether connector

The top tether connector should be ISOFIX top tether hook as shown in figure 0 (c), or similar devices that fit within the envelope given by figure 0 (c).

6.3.4.2. ISOFIX Top tether strap features

The ISOFIX top tether strap shall be supported by webbing (or its equivalent), having a provision for adjustment and release of tension.

6.3.4.2.1. ISOFIX Top tether strap length

ISOFIX Child Restraint System top tether strap length shall be at least 2,000 mm.

6.3.4.2.2. No-slack indicator

The ISOFIX top tether strap or the ISOFIX **Child Restraint System** shall be equipped with a device that will indicate that all slack has been removed from the strap. The device may be part of adjustment and tension relieving device.

6.3.4.2.3. Dimensions

Engagement dimensions for ISOFIX top tether hooks are shown in figure 0 (c).

Figure 0 (c)

ISOFIX Top tether connector (hook type) dimensions

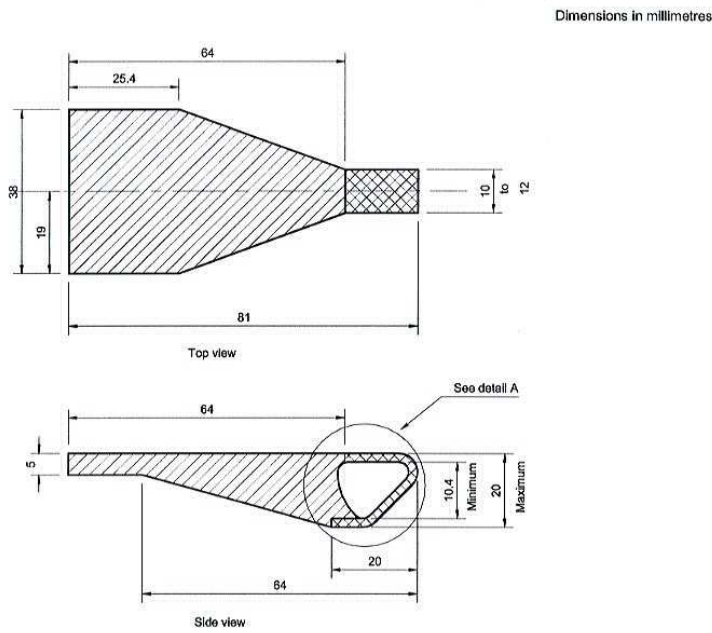

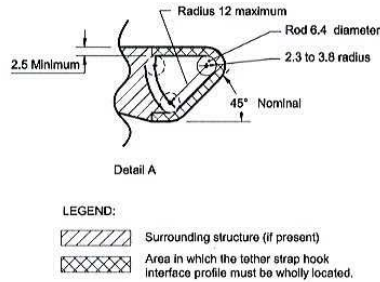

6.3.5. Child Restraint System support-leg and support-leg foot requirements

In paragraph 6.3.4. and its sub paragraphs, all measurements are given in relation to the ISOFIX attachments. The (X,Y,Z) origin is located in the middle between the two ISOFIX attachments and on the centre line of the corresponding ISOFIX anchorage bars. The X direction is horizontal and parallel to the Child Restraint System bottom surface, and the Z direction is vertical and perpendicular to the Child Restraint System bottom surface (see figure 0(d)). The Y direction is the transverse direction of the Child Restraint System and parallel to the corresponding ISOFIX anchorage bars in the vehicle.

For the requirements in this chapter, the Child Restraint System shall be installed as instructed in the user manual of the Child Restraint System. The storage position of the support-leg is excluded from these requirements.

6.3.5.1. Support-leg contact volume requirements

Where the Child Restraint System is fitted with a support-leg, its support-leg foot must meet the following requirements (see figure 0(d)):

- (a) The complete support-leg foot must lie fully inside the support-leg contact volume in the X and Y directions.
- (b) The support-leg must be adjustable, so that the support-leg foot contact surface must reach at least from Zlong to Zshort.
- (c) Zshort is [190] mm from the origin as defined in §6.3.4, measured in the Z direction.
- (d) Zlong is [490] mm from the origin as defined in §6.3.4, measured in the Z direction.
- (e) The adjustment capability of the support-leg must allow the support-leg foot to reach multiple positions between Zlong to Zshort with maximum incremental steps of 20 mm between the positions. A support-leg which allows continuous adjustment from Zlong to Zshort is also considered to meet this criterion.
- (f) An adjustment capability of the support-leg foot in the Z direction above and below the support-leg contact volume (see figure XY below; “Allowed zone”) is explicitly allowed.
- (g) Xshort must be [620] mm or more, from the origin as defined in §6.3.4., measured in the X direction.

- (h) X_{long} must be [820] mm or less, from the origin as defined in §6.3.4, measured in the X direction.
- (i) It is not a requirement for the support-leg foot to have adjustment possibilities in the X direction.
- (j) The support-leg foot is not allowed to have either a fixed position, or adjustable positions that lie outside the support-leg contact volume in the X direction (as indicated in figure XY below with a shaded grey color; “Not allowed zone”).
- (k) The contact volume is centered with respect to the XZ plane passing through the origin, as defined in §6.3.4, and its width in the Y direction is 200 mm.

Figure 0(d)

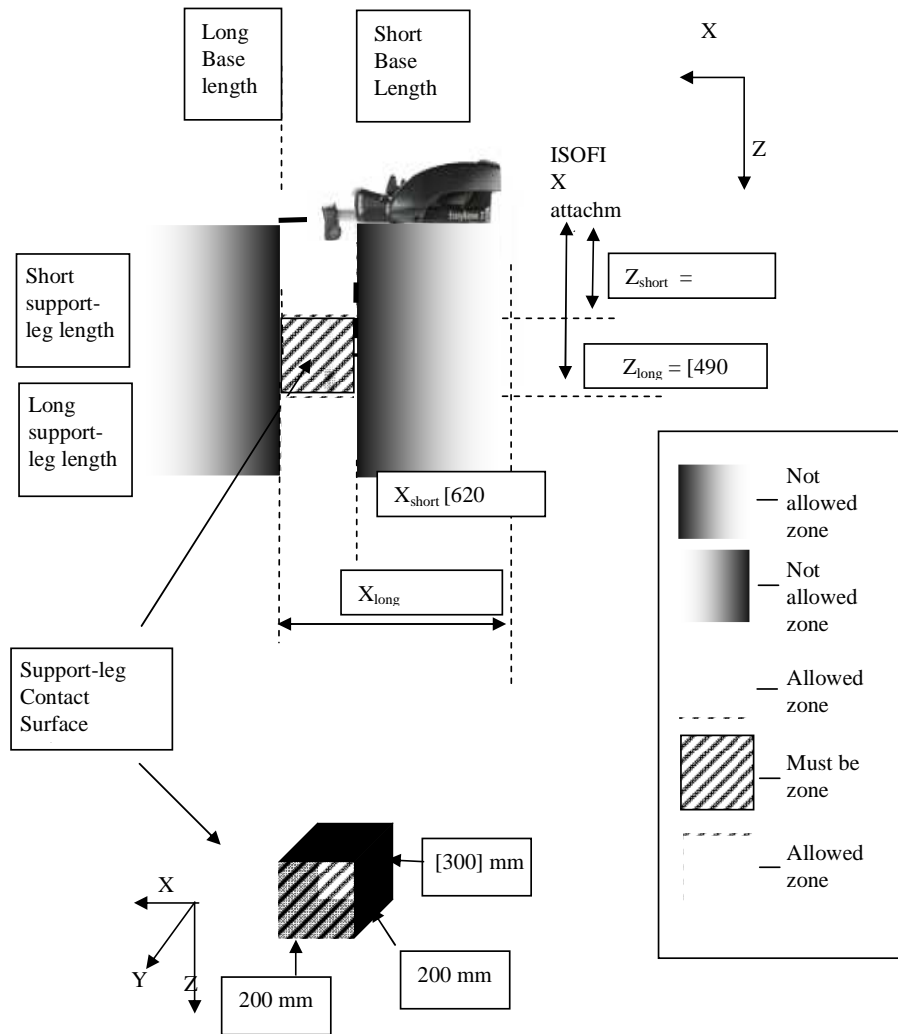

6.3.5.2. Vehicle jig for the support-leg

A jig is designed (see figure 0(e)) to check if the support-leg foot of the Child Restraint System meets the requirements defined in paragraph 6.3.4.1. A computer simulation may be used to check the dimensions defined in §6.3.4.1 is also considered to be satisfactory.

An **①**-Size Child Restraint System with a support-leg adjusted at any possible position, as checked by the jig, must meet the requirements of §6.3.4.1.

Figure 0(e)

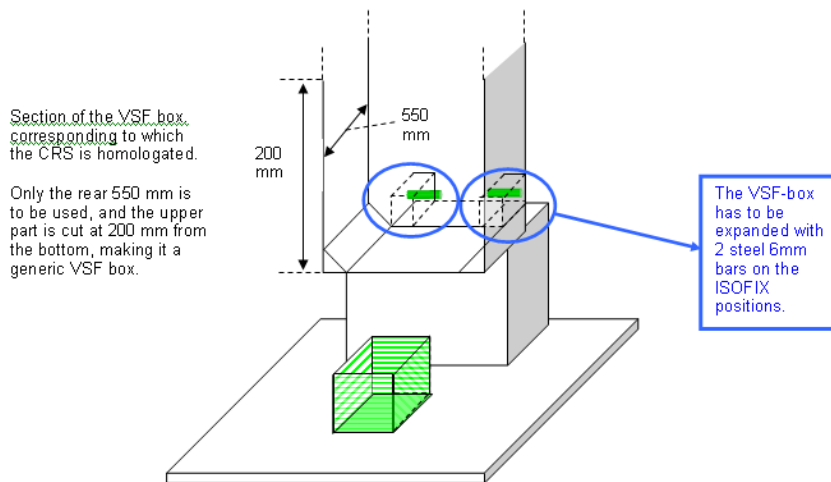

6.3.5.3. Support-leg foot dimensions

The dimensions of the support-leg foot must meet the following requirements:

- (a) **Minimal support-leg contact surface shall be 2500mm², measured as a projected surface 10 mm above the lower edge of the support-leg foot (see figure 0(f)).**
- (b) **Minimum outside dimensions are 30 mm in the X and Y directions, and maximum dimensions are limited by the contact volume.**
- (c) **Minimum radius of the edges of the support-leg foot shall be 3.2 mm.**

Figure 0(f)

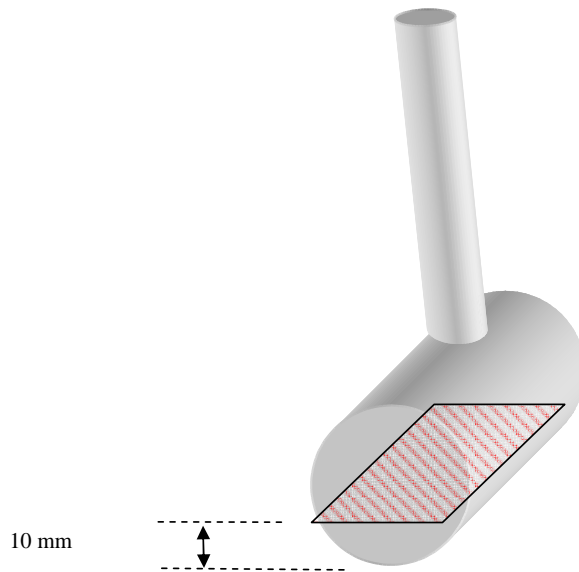

- 6.4. Control of Markings
- 6.4.1. The Technical Service conducting the approval tests shall verify that the markings conform to the requirements of paragraph 4.
- 6.5. Control of Instructions on Installation and the Instructions for Use
- 6.5.1. The Technical Service conducting the approval tests shall verify that the instructions on installation and the instructions for use conform to paragraph 13.
- 6.6. Provisions applicable to the assembled Child Restraint System
- 6.6.1. Resistance to corrosion
- 6.6.1.1. A complete Child Restraint System, or the parts thereof that are liable to corrosion, shall be subject to the corrosion test specified in paragraph 7.1.1. below.
- 6.6.1.2. After the corrosion test as prescribed in paragraphs 7.1.1.1. and 7.1.1.2., no signs of deterioration likely to impair the proper functioning of the Child Restraint System, and no significant corrosion, shall be visible to the unaided eye of a qualified observer.
- 6.6.2. Energy absorption
- 6.6.2.1. For all devices with backrests there shall be internal surfaces, defined in Annex 15 to this Regulation, comprising material with a peak acceleration of less than 60g when measured in accordance with Annex 14 to this Regulation. This requirement applies also to areas of impact shields which are in the head strike area.

- 6.6.2.2. In the case of Child Restraint Systems with permanent mechanically attached adjustable head support devices, in which the height of the child harness is directly controlled by the adjustable head support, it is not necessary to demand energy absorbing material in areas as defined in Annex 15, which are not contactable by the manikin’s head, i.e. behind the head support.
- 6.6.3. Overturning
- 6.6.3.1. The Child Restraint System shall be tested as prescribed in paragraph 7.1.2.; the manikin shall not fall out of the device and, when the test seat is in the upside down position the manikin's head shall not move more than 300 mm from its original position in a vertical direction relative to the test seat.
- ~~6.6.4. Geometrical characteristics~~
~~The Technical Service conducting the approval tests shall verify that the dimensions of the child restraint system conform to the requirements of table 1. For any size within the size range declared by the manufacturer the minimum dimensions of shoulder breadth, hip breadth and sitting height must be fulfilled together with the minimum and maximum dimensions of shoulder height.~~
 (Delete former table 2)
- 6.6.4. Dynamic test
- 6.6.4.1. General: the Child Restraint System shall be subjected to dynamic tests, in accordance with **Table 2**, in conformity with paragraph 7.1.3.-below:

Table 2

Application of different criteria depending of test set up

Frontal Impact				Rear Impact		Side-Lateral Impact	
Test on trolley+ Standard chair-seat		Test in car body		Test on trolley+ Standard chair-seat	Test in car body	Test on trolley+ Standard chair-seat	
Forward facing	Rearward and Lateral facing	Forward facing	Rearward and Lateral facing	Rearward and Lateral facing	Rearward and Lateral facing	Forward Facing	Rearward and Lateral facing

Note: Standard seat means test seat or test bench

- 6.6.4.1.1. ~~Ⓢ~~-Size ~~child-restraint system~~ **Child Restraint Systems** category shall be tested on the test trolley by means of the test seat prescribed in Annex 6, and in conformity with paragraph 7.1.3.1.;
- ~~6.6.4.1.2. Child Restraint Systems of the ~~Ⓢ~~-Size ~~Integral~~ “specific vehicle” **ISOFIX** category shall be tested with each vehicle model for which the Child Restraint System is intended. The Technical Service responsible for conducting the test may reduce the number of vehicle models tested if they do not differ greatly in the aspects listed in paragraph 6.6.4.1.2.3. The Child Restraint System may be tested in one of the following ways:~~
- 6.6.4.1.2.1. on a complete vehicle, as prescribed in paragraph 7.1.3.3.;

Deleted: [

- 6.6.4.1.2.2. in a vehicle body shell on the test trolley, as prescribed in paragraph 7.1.3., except for lateral impact ; or
- 6.6.4.1.2.3. in sufficient parts of the vehicle body shell to be representative of the vehicle structure and impact surfaces. If the Child Restraint System is intended for use in the rear seat, these shall include the back of the front seat, the rear seat, the floor pan, the B and C pillars and the roof. If the Child Restraint System is intended for use in the front seat, the parts shall include the dashboard, the A pillars, the windscreen, any levers or knobs installed in the floor or on a console, the front seat, the floor pan and the roof. The Technical Service responsible for conducting the test may permit items to be excluded if they are found to be superfluous. Testing shall be as prescribed in paragraph 7.1.3.2., except for lateral impact.
- 6.6.4.1.3. The dynamic test shall be performed on Child Restraint Systems which have not previously been under load.
- 6.6.4.1.4. If a ~~⊕~~-Size **Integral** “specific vehicle” **ISOFIX** Child Restraint System is installed in the area behind the rearmost forward facing adult seat positions (for example, the luggage area), one test with the largest ~~dummy/dummies~~ **manikin/manikins, as allowed by the Child Restraint System,** on a complete vehicle as prescribed in paragraph 7.1.3.3.3. shall be performed. The other tests, including the conformity of production, may be done as prescribed in paragraph 7.1.3.3.2., ~~if at the request of the manufacturer – so wishes.~~
- 6.6.4.1.5. In the case of a “Special Needs Restraint” every dynamic test specified by this Regulation for the range of size specified by the manufacturer shall be performed twice: first, using the primary means of restraint and second, with all restraining devices in use. In these tests, special attention shall be given to the requirements in paragraphs 6.2.1.5. and 6.2.1.6.
- 6.6.4.1.6. In the case of an ~~⊕~~-Size Child Restraint System making use of an anti-rotation device, the dynamic test shall be carried out as follows:
- 6.6.4.1.6.1. With the anti-rotation device in use, and
- 6.6.4.1.6.2. Without the anti-rotation device in use, unless ~~special device a mechanism~~ **a mechanism** is provided to prevent ~~non incorrect~~ **incorrect** use of the anti-rotation device.
- 6.6.4.2. During the dynamic tests, no part of the Child Restraint System ~~actually helping to keep,~~ **keeping** the child in position, shall break, and no buckles or locking system or displacement system shall release. ~~It is permissible for parts~~ **Parts** of the seat ~~to may~~ **may** deform provided ~~in doing so~~ it does not directly affect the integrity of the seat to protect the occupant.
- 6.6.4.3. ~~Dummy-Manikin~~ **Dummy-Manikin** criteria for frontal and rear impact **only for phase 2.**
- ~~[6.6.5.3.1. Abdominal penetration: during the frontal impact the “Resultant of Fx and Fz” measured in the lower lumbar spine shall not exceed [xx] per cent of the lap belt force; this ratio shall be measured instantaneous with respect to time.]~~
- 6.6.4.3.1. Injury assessment criteria for frontal and rear impact **as in table 3.**

Deleted:]

Table 3

Criterion	Abbreviation	Unit	Q0	Q1	Q1,5	Q3	Q6
Head Impact Criterion (only in case of contact during in-vehicle testing)	HIC (15)		523-671 600	491-629 600	578-741 600	780-1000 800	1083-1389 800
Head Acceleration 3ms	A head 3ms	g	85-75	72-75	76-75	81-80	89-80
Upper Neck Tension Force	Fz	N			For monitoring purpose only		
Upper Neck Flexion Moment	My	Nm			For monitoring purpose only		
Chest Deflection Only for phase 2	D chest	mm	NA	40	38	36	33
Chest Acceleration 3 ms	A chest 3ms	g	55	55	55	55	55

6.6.4.4. Manikin’s head displacement for frontal and rear impact

6.6.4.4.1. Child Restraint Systems of the ³ -Size category:

6.6.4.4.1.1. Forward facing Child Restraint Systems:

Head excursion: no part of the head of the manikin shall pass beyond the planes BA, ~~and~~ DA and DE as defined in figure 1 below. This shall be judged up to 300 ms or the moment that the manikin has come to a definitive standstill whatever occurs first.

6.6.4.4.1.2. **If a test is conducted according to the paragraph 6.6.4.1.6.2, a tolerance of +10 per cent is applicable to the head excursion value ~~distance~~ between Cr point and plane AB.**

Formatted: English U.S.

Deleted: To be reviewed within 3 years following entry into force of this regulation (Refers to EEVC WG12 values)

Formatted: English U.S.

Formatted: English U.S.

Formatted: Font: (Default) Times New Roman Bold, Complex Script Font: Times New Roman Bold, Superscript

Deleted: To be reviewed within 3 years following entry into force of this regulation (Refers to EEVC WG12 values)

Formatted: English U.S.

Formatted: English U.S.

Deleted: [

Deleted: .]

³ To be reviewed within 3 years following entry into force of this regulation (Refers to EEVC WG12 values)

Formatted: English U.S.

Figure 1
Arrangement for testing a forward-facing device

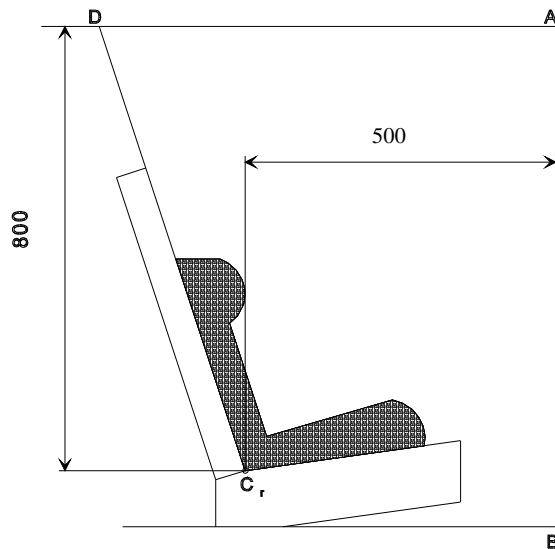

Dimensions in mm

6.6.4.4.1.2. Rearward-facing Child Restraint Systems and carrycots:

[6.6.4.4.1.2.1. Head exposure: during the dynamic tests the head ~~must remain fully contained within the child restraint [shell / system] (i.e. the top of the dummy's head must not be exposed exceed the protective shell of the CRS or (options to the possibility of direct contact with surfaces of the vehicle) be selected during evaluation phase) a marker on the dummy's head (side view) must not show a complete [black circle] (side view camera).] *to be deleted (see annex 19).*~~

Formatted: English U.S.

Formatted: English U.S.

Formatted: English U.S.

6.6.4.4.1.2.2. Head excursion: no part of the head of the manikin shall pass beyond the planes FD, FG and DE, as shown in figure 2 below. This shall be judged up to 300 ms or the moment that the manikin has come to a definitive standstill whatever occurs first.

In the case there is a contact of such a Child Restraint System with the 100 mm diameter bar and all injury assessment and manikin's head displacement criteria are met, there shall be one further dynamic test (front impact) with the heaviest ~~dummy manikin~~ intended for the given range of size indication and without the 100 mm diameter bar; the requirements for this test are that all criteria other than forward displacement shall be met.

Figure 2
Arrangement for testing a rearward-facing device, not supported by the dashboard

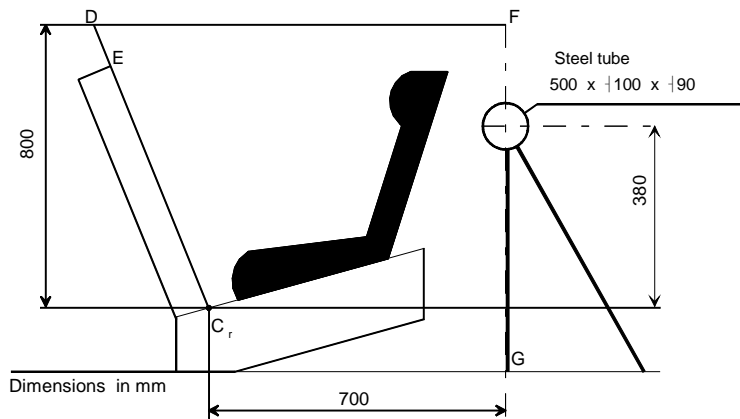

6.6.4.4.2. Child Restraint Systems of the “~~Q~~”-Size specific vehicle” category: when tested in a complete vehicle or a vehicle body shell, the head shall not come into contact with any part of the vehicle. However, if there is contact, the head impact criterion HIC and the Head Acceleration 3ms shall be used as assessment criteria. In tests with complete vehicles it shall be possible to remove the manikins from the Child Restraint System without the use of tools after the test.

6.6.4.4.3. ~~Dummy~~ **During the dynamic tests, no part of the Child Restraint System restraining the child in position shall fail. This includes buckles, locking systems and reclining systems, except where identified as a load limiting device. Any load limiting device must be identified in the manufacturers’ technical descriptions as defined in paragraph 3.2.1.**

Formatted: English U.S.
 Formatted: English U.S.
 Formatted: English U.S.
 Formatted: English U.S.
 Formatted: English U.S.

6.6.4.5. **Manikin criteria for lateral impact for forward and rearward facing Child Restraint System.**

6.6.4.5.1. Main injury assessment criterion — Head containment

During the loading phase of lateral impact testing, up to 80 ms, side protection shall always be positioned at the level at the ~~dummy’s~~ **manikin’s** head centre of gravity perpendicular to the direction of the door intrusion. ~~This containment will be assessed by a video analysis. Front on and overhead camera views are assessed.~~ Head containment will be assessed by the following criteria:

- (a) No head contact with the door panel.
- (b) Head must not exceed a **vertical plane identified by a red line** on top of the door (top view camera).

~~6.6.4.5.2. During the dynamic tests, no part of the Child Restraint System actually helping to keep restraining the child in position shall break, and no fail. This includes buckles, locking system or displacement system shall release. It is permissible for parts of systems and reclining systems, except where these are identified as a load limiting device and perform as predicted. Any load limiting device must be identified in the seat to deform provided in doing so it does not directly affect the integrity of the seat to protect the~~

Deleted: [(c) . Head must not exceed the side wing of the CRS or (options to be selected during evaluation phase) marker on dummies head (side view) must not show a complete black circle (side view camera).] **To be redefined.**
 . [A figure will describe head containment criteria]¶

occupant manufacturers' technical descriptions as defined in paragraph 3.2.1.

6.6.4.5.3. Additional Injury assessment criteria for lateral [To take into account energy absorbing HIC (36ms) or resultant head acceleration (3ms) should be considered. Values to be established after evaluation program.]

Criterion	Abbreviation	Unit	Q0	Q1	Q1,5	Q3	Q6
Head Impact Criterion	HIC (15)		600	600	600	800	800
Head Acceleration 3ms	A head 3ms	g	75	75	75	80	80

Upper Neck Tension Force Fz N For monitoring purpose only

Upper Neck Flexion Moment Mx Nm For monitoring purpose only

6.6.5. Resistance to temperature

6.6.5.1. Buckle assemblies, retractors, adjusters and lock-off devices that are liable to be affected by temperature, shall be subject to the temperature test specified in paragraph 7.2.7. below.

6.6.5.2. After the temperature test as prescribed in paragraph 7.2.7.1., no signs of deterioration likely to impair the proper functioning of the restraint of the child, shall be visible to the unaided eye of a qualified observer. The dynamic tests should then be performed.

6.7. Provisions applicable to individual components of the restraint

6.7.1. Buckle

6.7.1.1. The buckle shall be so designed as to preclude any possibility of incorrect manipulation. This means, inter/alia, that it must not be possible for the buckle to be left in a partially closed position; it must not be possible to exchange the buckle parts inadvertently when the buckle is being locked; the buckle must only lock when all parts are engaged. Wherever the buckle is in contact with the child, it shall not be narrower than the minimum width of strap as specified in paragraph 6.7.4.1.1. below. This paragraph is not applicable to belt assemblies already approved according to Regulation No. 16 or any equivalent standard in force. In the case of a "Special Needs Restraint" only the buckle on the primary means of restraint need comply with the requirements of paragraphs 6.7.1.2. to 6.7.1.8. inclusive.

6.7.1.2. The buckle, even when not under tension, shall remain closed whatever its position. It shall be easy to operate and to grasp. It shall be possible to open it by pressure on a button or on a similar device.

The surface to which this pressure must be applied must have, in the position of actual unlocking and when projected into a plane perpendicular to the button's initial direction of motion:

- (a) for enclosed devices, an area of not less than 4.5 cm² with a width of not less than 15 mm;

Formatted: English U.S.

Deleted: [

Deleted: To be reviewed within 3 years following entry into force of this regulation (Refers to EEVC WG12 values)

Deleted:]

Formatted: English U.S.

Formatted: English U.S.

Deleted: [

Formatted: Font: (Default) Times New Roman Bold, Complex Script Font: Times New Roman Bold, Subscript

Deleted: To be reviewed within 3 years following entry into force of this regulation (Refers to EEVC WG12 values)]

Formatted: English U.S.

Deleted: 6.6.4.6. . . Manikin criteria for lateral impact for lateral facing Child Restraint System (carry-cot)¶
 . To be defined¶

⁴ To be reviewed within 3 years following entry into force of this regulation (Refers to EEVC WG12 values)

Formatted: Font: (Default) Times New Roman Bold, Complex Script Font: Times New Roman Bold,

Formatted: English U.S.

- (b) for non-enclosed devices, an area of 2.5 cm² and a width of not less than 10 mm. The width shall be the smaller of the two dimensions forming the prescribed area and shall be measured rectangular to the direction of movement of the release button.
- 6.7.1.3. The buckle release area shall be coloured red. No other part of the buckle shall be of this colour.
- 6.7.1.4. It shall be possible to release the child from the restraint by a single operation on a single buckle. It is allowed to remove the child together with devices such as infant carrier/carry-cot/carry-cot restraints if the Child Restraint System can be released by operation of a maximum of two release buttons.
- 6.7.1.4.1. Shoulder strap positioner
 - ~~A clip connection between the shoulder straps of a harness belt is deemed not to comply with the single operation requirement given in paragraph 6.7.1.4. above.~~
 - If a shoulder strap positioner is provided, it shall be designed so as to prevent incorrect manipulation. It must not be possible to use the device in a manner which would cause the shoulder straps to twist. It must be possible to fasten the device in no more than one action. The force required to fasten the device must not exceed 15N.**
- 6.7.1.4.2. **The shoulder strap positioner shall be easy to operate and to grasp. It shall be possible to open it in one simple action, but it shall be difficult for the child occupant to manipulate the release mechanism. The force required to release the device must not exceed 15N.**
- 6.7.1.4.3. **The shoulder strap positioner must not exceed 60mm in height.**
- 6.7.1.5. Opening of the buckle shall enable the child to be removed independently of the “chair”, “chair support” or “impact shield”, if fitted, and if the device includes a crotch strap the crotch strap shall be released by operation of the same buckle.
- 6.7.1.6. The buckle shall be capable of withstanding the temperature test operation requirements given in paragraph 7.2.7. and repeated operation, and shall, before the dynamic test prescribed in paragraph 7.1.3. undergo a test comprising 5,000 ± 5 opening and closing cycles under normal conditions for use.
- 6.7.1.7. The buckle shall be subjected to the following tests of opening:
 - 6.7.1.7.1. Test under load
 - 6.7.1.7.1.1. A Child Restraint System having already undergone the dynamic test prescribed in paragraph 7.1.3. below shall be used for this test.
 - 6.7.1.7.1.2. The force required to open the buckle in the test prescribed in paragraph 7.2.1.1. shall not exceed 80 N.
 - 6.7.1.7.2. No-load test
 - 6.7.1.7.2.1. A buckle which has not previously been subjected to a load shall be used for this test. The force needed to open the buckle when it is not under load shall be in the range of 40–80 N in the tests prescribed in paragraph 7.2.1.2.
- 6.7.1.8. Strength

- 6.7.1.8.1. During the test in accordance with paragraph 7.2.1.3.2. no part of the buckle or the adjacent straps or adjusters shall break or be detached.
- 6.7.1.8.2. Depending of the mass limit declared by the manufacturer, a harness buckle shall withstand:
 - 6.7.1.8.2.1. 4 kN, if the mass limit is less or equal to 13 kg;
 - 6.7.1.8.2.2. 10 kN, if the mass limit is greater than 13 kg.
- 6.7.1.8.3. The competent authority may dispense with the buckle strength test if information already available renders the test superfluous.
- 6.7.2. Adjusting device
 - 6.7.2.1. The range of adjustment shall be sufficient to permit correct adjustment of the Child Restraint System with all size for which the device is intended and to permit satisfactory installation in all D -Size compatible vehicles.
 - 6.7.2.2. All adjusting devices shall be of the “quick adjuster” type.
 - 6.7.2.3. Devices of the “quick adjuster” type shall be easy to reach when the Child Restraint System is correctly installed and the child or manikin is in position.
 - 6.7.2.4. A device of the “quick adjuster” type shall be easily adjustable to the child's physique. In particular, in a test performed in accordance with paragraph 7.2.2.1., the force required to operate a manual adjusting device shall not exceed 50 N.
 - 6.7.2.5. Two samples of the child-restraint system adjusting devices shall be tested as prescribed by the temperature test operation requirements given in paragraph 7.2.7.1. and paragraph 7.2.3. below.
 - 6.7.2.5.1. The amount of strap slip shall not exceed 25 mm for one adjusting device or 40 mm for all adjusting devices.
 - 6.7.2.6. The device must not break or become detached when tested as prescribed in paragraph 7.2.2.1.
 - 6.7.2.7. An adjuster mounted directly on the Child Restraint System shall be capable of withstanding repeated operation and shall, before the dynamic test prescribed in paragraph 7.1.3. undergo a test comprising $5,000 \pm 5$ cycles as specified in paragraph 7.2.3.
- 6.7.3. Retractors
 - 6.7.3.1. Automatically-locking retractors
 - 6.7.3.1.1. The strap equipped with an automatically-locking retractor shall not unwind by more than 30 mm between locking positions of the retractor. After a rearward movement of the wearer the strap must either remain in its initial position or return to that position automatically on subsequent forward movement of the wearer.
 - 6.7.3.1.2. If the retractor is part of a lap belt, the retracting force of the strap shall be not less than 7 N as measured in the free length between the manikin and the retractor as prescribed in paragraph 7.2.4.1. below. If the retractor is part of a chest restraint, the retracting force of the strap shall be not less than 2 N or more than 7 N as similarly measured. If the strap passes through a guide or pulley, the retracting force shall be measured in the free length between the manikin and the guide or pulley. If the assembly incorporates a device,

manually or automatically operated, that prevents the strap from being completely retracted, that device shall not be in operation when these measurements are effected.

- 6.7.3.1.3. The strap shall be repeatedly withdrawn from the retractor and allowed to retract, in the conditions prescribed in paragraph 7.2.4.2. below, until 5,000 cycles have been completed. The retractor shall then be subjected to the temperature test operation requirements given in paragraph 7.2.7.1. and corrosion test described in paragraph 7.1.1. and the dust-resistance test described in paragraph 7.2.4.5. It shall then satisfactorily complete a further 5,000 cycles of withdrawal and retraction. After the above tests the retractor shall continue to operate correctly and to meet the requirements of paragraphs 6.7.3.1.1. and 6.7.3.1.2. above.
- 6.7.3.2. Emergency-locking retractors
- 6.7.3.2.1. An emergency-locking retractor shall when tested as prescribed in paragraph 7.2.4.3. satisfy the conditions below:
- 6.7.3.2.1.1. it shall be locked when the deceleration of the vehicle reaches 0.45 g;
- 6.7.3.2.1.2. it shall not lock for strap accelerations of less than 0.8 g as measured in the axis of strap extraction;
- 6.7.3.2.1.3. it shall not lock when its sensing device is tilted by not more than 12° in any direction from the installation position specified by its manufacturer;
- 6.7.3.2.1.4. it shall lock when its sensing device is tilted by more than 27° in any direction from the installation position specified by its manufacturer.
- 6.7.3.2.2. Where the operation of a retractor depends on an external signal or power source, the design shall ensure that the retractor locks automatically upon failure or interruption of that signal or power source.
- 6.7.3.2.3. A multiple-sensitivity emergency-locking retractor shall meet the requirements set out above. In addition, if one of the sensitivity factors relates to strap extraction, locking must have occurred at a strap acceleration of 1.5 g as measured in the axis of strap extraction.
- 6.7.3.2.4. In the tests referred to in paragraphs 6.7.3.2.1.1. and 6.7.3.2.3. above, the amount of strap extraction occurring before the retractor locks shall not exceed 50 mm, starting at the length of unwinding specified in paragraph 7.2.4.3.1. In the test referred to in paragraph 6.7.3.2.1.2. above, locking shall not occur during the 50 mm of strap extraction starting at the length of unwinding specified in paragraph 7.2.4.3.1. below.
- 6.7.3.2.5. If the retractor is part of a lap belt, the retracting force of the strap shall be not less than 7 N as measured in the free length between the manikin and the retractor as prescribed in paragraph 7.2.4.1. If the retractor is part of a chest restraint, the retracting force of the strap shall be not less than 2 N or more than 7 N as similarly measured. If the strap passes through a guide or pulley, the retracting force shall be measured in the free length between the manikin and the guide or pulley. If the assembly incorporates a device, manually or automatically operated, that prevents the strap from being completely retracted, that device shall not be in operation when these measurements are effected.
- 6.7.3.2.6. The strap shall be repeatedly withdrawn from the retractor and allowed to retract, in the conditions prescribed in paragraph 7.2.4.2., until 40,000 cycles

have been completed. The retractor shall then be subjected to the temperature test operation requirements given in paragraph 7.2.4.1. and corrosion test described in paragraph 8.1.1 and to the dust-resistance test described in paragraph 7.2.4.5. It shall then satisfactorily complete a further 5,000 cycles of withdrawal and retraction (making 45,000 in all). After the above tests the retractor shall continue to operate correctly and to meet the requirements of paragraphs 6.7.3.2.1. to 6.7.3.2.5. above.

- 6.7.4. Straps
- 6.7.4.1. Width
 - 6.7.4.1.1. The minimum width at the child-restraint straps which contact the ~~dummy~~ **manikin** shall be 25 mm. These dimensions shall be measured during the strap strength test prescribed in paragraph 7.2.5.1., without stopping the machine and under a load equal to 75 per cent of the breaking load of the strap.
 - 6.7.4.2. Strength after room conditioning
 - 6.7.4.2.1. On two sample straps conditioned as prescribed in paragraph 7.2.5.2.1., the breaking load of the strap shall be determined as prescribed in paragraph 7.2.5.1.2. below.
 - 6.7.4.2.2. The difference between the breaking loads of the two samples shall not exceed 10 per cent of the greater of the two breaking loads measured.
 - 6.7.4.3. Strength after special conditioning
 - 6.7.4.3.1. On two straps conditioned as prescribed in one of the provisions of paragraph 7.2.5.2. (except paragraph 7.2.5.2.1.), the breaking load of the strap shall be not less than 75 per cent of the average of the loads determined in the test referred to in paragraph 7.2.5.1. below.
 - 6.7.4.3.2. In addition, the breaking load shall be not less than 3.6 kN for the restraints of -Size Child Restraint Systems.
 - 6.7.4.3.3. The competent authority may dispense with one or more of these tests if the composition of the material used, or information already available, renders the test or tests superfluous.
 - 6.7.4.3.4. The abrasion conditioning procedure of type 1 defined in paragraph 7.2.5.2.6. shall only be performed when the microslip test defined in paragraph 7.2.3. below gives a result above 50 per cent of the limit prescribed in paragraph 6.7.2.5.1. above.
 - 6.7.4.4. It shall not be possible to pull the complete strap through any adjusters, buckles or anchoring points.
- 6.7.5. ISOFIX attachment specifications

“ISOFIX attachments” and latching indicators shall be capable of withstanding repeated operations and shall, before the dynamic test prescribed in paragraph 7.1.3., undergo a test comprising 2000 ± 5 opening and closing cycles under normal conditions of use.
- 6.8. Classification
 - 6.8.1. Child Restraint Systems may cover any size range provided that the requirements for the whole range are fulfilled. ~~Moreover the size range has to~~

be indicated on the child restraint system and at least the shoulder heights belonging to this size range must be clearly visible for the user.]

7. Tests

7.1. Tests of the assembled Child Restraint System

7.1.1. Corrosion

7.1.1.1. The metal items of the Child Restraint System shall be positioned in a test chamber as prescribed in Annex 4. In the case of a Child Restraint System incorporating a retractor, the strap shall be unwound to full length less 100 ± 3 mm. Except for short interruptions that may be necessary, for example, to check and replenish the salt solution, the exposure test shall proceed continuously for a period of 50 ± 0.5 hours.

7.1.1.2. On completion of the exposure test the metal items of the Child Restraint System shall be gently washed, or dipped, in clean running water with a temperature not higher than 38°C to remove any salt deposit that may have formed and then allowed to dry at room temperature of 18 to 25°C for 24 ± 1 hours before inspection in accordance with paragraph 6.6.1.2. above.

7.1.2. Overturning

7.1.2.1. The manikin shall be placed in the restraints installed in accordance with this Regulation and taking into account the manufacturer's instructions and with the standard slack as specified in paragraph 7.1.3.5.

7.1.2.2. The restraint shall be fastened to the test ~~seat-bench~~ or vehicle seat. The whole ~~seat-Child Restraint System~~ shall be rotated around a horizontal axis contained in the median longitudinal plane of the **Child Restraint System** ~~seat~~ through an angle of 360° at a speed of 2-5 degrees/second. For the purposes of this test, devices intended for use in specific cars may be attached to the test ~~seat-bench~~ described in Annex 6.

7.1.2.3. This test shall be carried out again rotating in the reverse direction after having repositioned, if necessary, the manikin in its initial position. With the rotational axis in the horizontal plane and at 90° to that of the two earlier tests, the procedure shall be repeated in the two directions of rotation.

7.1.2.4. These tests shall be carried out using both the smallest and the largest appropriate manikin of the size range for which the restraining device is intended.

7.1.3. Dynamic tests for frontal, rear and ~~side-lateral~~ impact

7.1.3.1. Tests on the trolley and test ~~seat-bench~~

7.1.3.1.1. Frontal and rear impact

7.1.3.1.1.1. The trolley and test ~~seat-bench~~ used in the dynamic test shall meet the requirements of Annex 6 to this Regulation, and the dynamic crash test installation procedure is to be in accordance with Annex 18.

7.1.3.1.1.2. The trolley shall remain horizontal throughout deceleration or acceleration.

7.1.3.1.1.3. **The test bench shall be rotated 180° when testing in compliance with the requirements of the rear impact test.**

Deleted: [

Deleted:]

7.1.3.1.1.4. When testing a rearward-facing Child Restraint System intended for use in the front seating position, the vehicle facia shall be represented by a rigid bar attached to the trolley in such a way that all the energy absorption takes place in the Child Restraint System.

7.1.3.1.1.5. Deceleration or acceleration devices

The applicant shall choose to use one of the two following devices:

7.1.3.1.1.5.1. Deceleration test device:

The deceleration of the trolley shall be achieved by using the apparatus prescribed in Annex 6 to this Regulation or any other device giving equivalent results. This apparatus shall be capable of the performance specified in paragraph 7.1.3.4. and hereafter specified:

Calibration procedure:

The deceleration curve of the trolley, in the case of Child Restraint System tests performed in accordance with paragraph 7.1.3.1., ballasted with inert masses up to 55 kg in order to reproduce one occupied Child Restraint System, and in the case of Child Restraint System tests in a vehicle body shell performed in accordance with paragraph 7.1.3.2., where the trolley is ballasted with the vehicle structure and inert masses up to [x times] 55 kg reproducing the number of [x] occupied Child Restraint Systems, must remain, in the case of frontal impact, within the hatched area of the graph in Annex 7, Appendix 1 of this Regulation, and, in the case of rear impact, within the hatched area of the graph in Annex 7, Appendix 2 of this Regulation.

During calibration of the stopping device, the stopping distance shall be 650 ± 30 mm for frontal impact, and 275 ± 20 mm for rear impact.

Dynamic testing conditions during testing:

For frontal and rear impact the deceleration shall be achieved with the apparatus calibrated as stated above, however:

- (a) The deceleration curve shall not have a more than 3 ms time duration exceedance of the lower borders of the performance requirements;
- (b) If the tests above were performed at a higher speed and/or the deceleration curve has exceeded the upper level of the hatched area and the Child Restraint System meets the requirements, the test shall be considered satisfactory.

7.1.3.1.1.5.2. Acceleration test device

Dynamic testing conditions:

For frontal impact, the trolley shall be so propelled that, during the test, its total velocity change ΔV is $52 + 0 - 2$ km/h and its acceleration curve is within the hatched area of the graph in Annex 7, Appendix 1 and stay above the segment defined by the coordinates (5g, 10ms) and (9g, 20ms). The start of the impact (T0) is defined, according to ISO 17 373 for a level of acceleration of 0.5g.

For rear impact, the trolley shall be so propelled that, during the test, its total velocity change ΔV is $32 + 2 - 0$ km/h and its acceleration curve is within the hatched area of the graph in Annex 7, Appendix 2 and stay above the segment defined by the coordinates (5g, 5ms) and (10g, 10ms). The start of

the impact (T0) is defined, according to ISO 17 373 for a level of acceleration of 0.5g.

Despite the fulfilment of the above requirements, the Technical Service shall use a mass of trolley (equipped with its ~~seat~~**test bench**), as specified in paragraph 1. of Annex 6, superior to 380 kg.

However, if the tests above were performed at a higher speed and/or the acceleration curve has exceeded the upper level of the hatched area and the child restraint meets the requirements, the test shall be considered satisfactory.

- 7.1.3.1.1.6. The following measurements shall be made:
- 7.1.3.1.1.6.1. the trolley speed immediately before impact (only for deceleration sleds, needed for stopping distance calculation);
 - 7.1.3.1.1.6.2. the stopping distance (only for deceleration sleds), which may be calculated by double integration of the recorded sled deceleration;
 - 7.1.3.1.1.6.3. the displacement of the manikin's head in the vertical and horizontal direction of the tests with all Q-dummies necessary for the given -Size indication for at least the first 300 ms;
 - 7.1.3.1.1.6.4. the parameters required to perform the injury assessment against the criteria as mentioned in paragraph 6.6.4.3.1. for at least the first 300 ms;
 - 7.1.3.1.1.6.5. the trolley acceleration or deceleration for at least the first 300 ms.
 - 7.1.3.1.1.7. After impact, the child restraint shall be inspected visually, without opening the buckle, to determine whether there has been any failure or breakage.
- 7.1.3.1.2. Rear impact
- 7.1.3.1.2.1. The test seat shall be rotated 180° when testing in compliance with the requirements of the rear impact test.
 - 7.1.3.1.2.2. When testing a rearward-facing child restraint intended for use in the front seating position, the vehicle fascia shall be represented by a rigid bar attached to the trolley in such a way that all the energy absorption takes place in the child restraint.
 - 7.1.3.1.2.3. The deceleration conditions shall satisfy the requirements of paragraph 7.1.3.1.1.3.1.
The acceleration conditions shall satisfy the requirements of paragraph 7.1.3.1.1.3.2.
 - 7.1.3.1.2.4. The measurements to be made shall be similar to those listed in paragraphs 7.1.3.1.1.4. to 7.1.3.1.1.5. above.
- 7.1.3.1.3. Lateral impact
- 7.1.3.1.3.1. The test ~~seat~~**bench** shall be rotated 90° when testing in compliance with the requirements of the lateral impact test.
 - 7.1.3.1.3.2. The lower ISOFIX anchorages should be movable in the Y direction to avoid damage of the attachments and to the test equipment. The ISOFIX anchorages are [individually] fixed to a sliding system allowing a movement ~~up to [X] of 200 mm -0 mm +50 mm.~~

- 7.1.3.1.3.3. The lateral impact loading to the CRS is generated by a door panel as defined in Annex 6. The stiffness and strength of the door panel shall be sufficient to avoid excessive oscillation or significant deformation during lateral dynamic test. The surface of the panel is covered with padding as specified in Annex 7, **Appendix 4**.
- 7.1.3.1.3.4. The test rig shall reproduce a relative velocity between the door panel and the test bench in compliance with Annex 7 Appendix 3. The initial relative velocity between the door panel and the bench is [7.3] m/s +/- 0.2 m/s. The maximum intrusion depth of the door panel is defined in Annex 7 Appendix 3. The relative velocity between the door panel and the test bench shall not be affected by contact with the CRS and shall remain within the corridor defined in Annex 7, appendix 3.
- 7.1.3.1.3.5. The CRS is tested in its most upright position.
- 7.1.3.1.3.6. At time t_0 defined Annex 7 Appendix 3, the ~~dummy~~ **manikin** must be in its initial position as defined in Annex 18.
- 7.1.3.2. Test on trolley and vehicle body shell
- 7.1.3.2.1. Frontal impact
- 7.1.3.2.1.1. The method used to secure the vehicle during the test shall not be such as to strengthen the anchorages of the vehicle seats, adult safety belts and any additional anchorages required to secure the child restraint or to lessen the normal deformation of the structure. No part of the vehicle shall be present which, by limiting the movement of the manikin, would reduce the load imposed on the child restraint during the test. The parts of the structure eliminated may be replaced by parts of equivalent strength, provided they do not hinder the movement of the manikin.
- 7.1.3.2.1.2. A securing device shall be regarded as satisfactory if it produces no effect on an area extending over the whole width of the structure and if the vehicle or structure is blocked or fixed in front at a distance of not less than 500 mm from the anchorage of the restraint system. At the rear the structure shall be secured at a sufficient distance behind the anchorages to ensure that all requirements of paragraph 7.1.3.2.1.1. above are fulfilled.
- 7.1.3.2.1.3. The vehicle seat and Child Restraint System shall be fitted and shall be placed in a position chosen by the Technical Service conducting approval tests to give the most adverse conditions in respect of strength, compatible with installing the manikin in the vehicle. The position of the vehicle seat-back and Child Restraint System shall be stated in the report. The vehicle seat-back, if adjustable for inclination, shall be locked as specified by the manufacturer or, in the absence of any specification, at an actual seat-back angle as near as possible to 25°.
- 7.1.3.2.1.4. Unless the instructions for fitting and use require otherwise, the front seat shall be placed in the most forward normally used position for child restraints intended for use in the front seating position, and in the rearmost normally used position for child restraints intended for use in the rear seating position.
- 7.1.3.2.1.5. The deceleration conditions shall satisfy the requirements of paragraph 7.1.3.4. below. The test ~~seat~~ **bench** will be the seat of the actual vehicle.
- 7.1.3.2.1.6. The following measurements shall be made:

- 7.1.3.2.1.6.1. the trolley speed immediately before impact (only for deceleration sleds, needed for stopping distance calculation);
- 7.1.3.2.1.6.2. the stopping distance (only for deceleration sleds), which may be calculated by double integration of the recorded sled deceleration;
- 7.1.3.2.1.6.3. any contact of the manikin's head with the interior of the vehicle body shell;
- 7.1.3.2.1.6.4. the parameters required to perform the injury assessment against the criteria as mentioned in paragraph 6.6.4.3.1. for at least the first 300 ms;
- 7.1.3.2.1.6.5. the trolley and vehicle body shell acceleration or deceleration for at least the first 300 ms.
- 7.1.3.2.1.7. After impact, the child restraint shall be inspected visually, without opening the buckle, to determine whether there has been any failure.
- 7.1.3.2.2. Rear impact
 - 7.1.3.2.2.1. For rear impact tests the vehicle body shell shall be rotated 180° on the test trolley.
 - 7.1.3.2.2.2. Same requirements as for frontal impact.
- 7.1.3.3. Test with complete vehicle
 - 7.1.3.3.1. The deceleration conditions shall satisfy the requirements of paragraph 7.1.3.4. below.
 - 7.1.3.3.2. For frontal impact tests the procedure shall be that set out in Annex 9 to this Regulation.
 - 7.1.3.3.3. For rear impact tests the procedure shall be that set out in Annex 10 to this Regulation.
 - 7.1.3.3.5. The following measurements shall be made:
 - 7.1.3.3.5.1. the speed of the vehicle/impactor immediately before impact (only for deceleration sleds, needed for stopping distance calculation);
 - 7.1.3.3.5.2. any contact of the manikin's head with the interior of the vehicle;
 - 7.1.3.3.5.3. the parameters required to perform the injury assessment against the criteria as mentioned in paragraph 6.6.4.3.1. for at least the first 300 ms.
 - 7.1.3.3.6. The front seats, if adjustable for inclination, shall be locked as specified by the manufacturer or, in the absence of any specification, at an actual seat-back angle as near as possible to 25°.
 - 7.1.3.3.7. After impact, the child restraint shall be inspected visually, without opening the buckle, to determine whether there has been any failure or breakage.
- 7.1.3.4. The conditions for dynamic test are summarized in the table below 4:

Deleted: 7.1.3.3.4. . For side lateral impact tests the procedure shall be that set out in Annex 11 to this Regulation.¶

Table 4

Test	Frontal Impact				Rear Impact			Lateral Impact		
	Restraint	Speed km/h	Test Pulse No.	Stopping distance during test (mm)	Speed km/h	Test pulse No.	Stopping distance during test (mm)	Speed km/h	Test pulse No.	Stopping distance during test (mm) [Maximum intrusion]

Trolley with test	forward facing	50+0 -2	1	650±50	30+2 -0 N.A.	2 N.A.	275±25 N.A.	26 +/- 1	3	[300]
	rearward facing	50+0 -2	1	650±50	30+2 -0	2	275±25	26 +/- 1	3	[300]
Seat bench	Lateral facing	50+0 -2	1	650±50	30+2 -0	2	275±25	TBD	TBD	TBD

Legend:

Test Pulse No. 1 – As prescribed in Annex 7 / Appendix 1 – frontal impact.

Test Pulse No. 2 – As prescribed in Annex 7 / Appendix 2 – rear impact.

Test Pulse No. 3 – As prescribed in Annex 7 / Appendix 3 – lateral impact

TBD: to be defined**N.A.: non applicable**

7.1.3.5. Dynamic test manikins

7.1.3.5.1. The Child Restraint System shall be tested using the manikins prescribed in Annex 8 to this Regulation.

7.1.3.5.2. Installation of the manikin for frontal and rear impacts

7.1.3.5.2.1. {The manikin shall be placed so that the gap is between the rear of the manikin and the restraint. In the case of carry-cots the manikin is placed in a straight horizontal position as close as possible to the centre line of the carry-cot-}

7.1.3.5.2.2. Place the Child Restraint System on the test ~~seat~~ **bench**.

Place the manikin in the Child Restraint System, such that:

[- the ~~dummy~~ **manikin**'s head is horizontal following the ...- the arms of the ~~dummy~~ **manikin** are placed following the ...]

Place a hinged board or a similar flexible **spacer** device 2.5 cm thick and 6 cm wide and of length equal to the shoulder height (sitting (Annex 8) less the ~~hip centre height (sitting, in Annex 8) popliteus height plus half of thigh height sitting (Annex 8)~~ relevant to the manikin size being tested between the manikin and the ~~seat~~ **seat-back** of the chair. The **resulting length of the spacer is listed in the table below for the different manikin sizes. The board should follow as closely as possible the curvature of the chair and its lower end should be at the height of the manikin's hip joint.**

	Q0	Q1	Q1.5	Q3	Q6	[Q10] (design targets)
	Dimensions in [mm]					
Height of spacer device for positioning of manikin		229±2	237±2	250±2	270±2	359±2

Adjust the belt in accordance with the manufacturer's instructions, but to a tension of 250 ± 25 N above the adjuster force, with a deflection angle of the strap at the adjuster of $45 \pm 5^\circ$, or alternatively, the angle prescribed by the manufacturer.

Complete the installation of the **Child Restraint System** to the test seat **bench** in accordance with Annex 18 to this Regulation.

Remove the flexible device.

This only applies to harness restraints and to restraints where the child is restrained by the adult three-point belt and where a lock-off device is used and does not apply to child restraining straps connected directly to a retractor.

7.1.3.5.2.3. The longitudinal plane passing through the centre line of the ~~dummy~~ **manikin** shall be set midway between the two lower belt anchorages, however note shall also be taken of paragraph 7.1.3.2.1.3.

7.1.3.5.3. Installation of the manikin for ~~side~~ **lateral** impact

7.1.3.5.3.1. Key parameters to be controlled:

- (a) Exact alignment of ~~dummy~~ **manikin** centre line with CRS centre line and CRS centre line with the centreline of the bench.
- (b) Pre impact stability of the ~~dummy~~ **manikin**.
- (c) Arm position in relation to the torso.

7.1.3.5.3.2. Installation is in general similar to that for frontal impact e.g. harness tension 250 N with spacer and ~~dummy~~ **manikin** shall be pushed toward the **seat-back** after removing the spacer.

CRS and ~~dummy~~ **manikin** centrelines aligned with bench centre line.

Arms shall be positioned symmetrical. Elbows **have** to be positioned in such a way that the upper arms are aligned with the sternum.

Hands shall be positioned on the thighs.

Legs shall be positioned parallel or at least symmetrical.

CRS and ~~dummy~~ **manikin** shall be kept stable until t_0 to be checked by markers at ~~dummy~~ **manikin**, CRS and sled. Any mean used to stabilise the ~~dummy~~ **manikin** before t_0 shall not influence the ~~dummy~~ **manikin** kinematics after t_0 .

[A figure is to be added here to illustrate dummy installation for side impact.]

• Explanation arm position

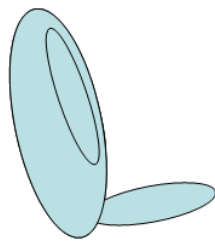

Upper arms are aligned with sternum

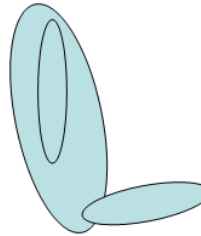

Upper arms are not aligned with sternum

7.1.3.6. **①**-Size indication

The manikin(s) that are used in testing will be the nominator for the **①**-Size indication that the child restraint may carry, in the following way:

The dynamic tests shall be conducted with the largest ~~dummy~~ **manikin** and the smallest ~~dummy~~ **manikin** defined in the following tables for according to the size **range** indication of the test CRS.

Table 6

Selection criteria for the smallest ~~dummy~~ manikin according to the ~~minimum size range indication~~:

<i>Minimum size indication</i>	≤ 60	60 < x ≤ 75	75 < x ≤ 87	87 < x ≤ 105	105 < x ≤ 125	>125
Manikin	Q0	Q1	Q1.5	Q3	Q6	Q10

In case of substantial modification of the **Child Restraint System** installation between different sizes (e.g., convertible **Child Restraint System**) or if the size range cover more than [3 or 4] size ranges the relevant intermediate ~~dummy~~ **manikin** according to the manufacturers advice shall be tested in addition to the ~~two dummies~~ **manikin** (s) defined above.

7.1.3.6.1. If the Child Restraint System is designed for two or more children, one test shall be carried out with the heaviest manikins occupying all seating positions. A second test with the lightest and the heaviest manikins specified above shall be carried out. The tests shall be conducted using the test seat **bench** as shown in Annex 6, Appendix 3, figure 3. The laboratory conducting the tests may, if it deems it advisable, add a third test with any combination of manikins or empty seat positions.

7.1.3.6.2. If the **①**-Size Child Restraint System uses a top tether, one test shall be carried out with the smallest **manikin** with the shorter distance of the top tether (anchorage point G1). A second test shall be carried out with the heavier ~~dummy~~ **manikin** with the longer distance of the top tether (anchorage point G2). Adjust the top tether to achieve a tension load of 50 ± 5 N. For ~~side-lateral~~ impact the ISOFIX child restraint must be tested with **only** the shorter distance of the top tether.

7.1.3.6.3. If the **①**-Size Child Restraint System uses a support-leg, as an anti-rotation device the hereafter mentioned dynamic tests shall be carried out as follows:

- (a) The tests for frontal impact shall be conducted with the support-leg adjusted to its maximum adjustment compatible with the positioning of the trolley floor pan. The tests for rear impact shall be conducted with the worst case position selected by the Technical Service. During the tests the support-leg shall be supported by the trolley floor pan as described in Annex 6, Appendix 3, figure 2.
- (b) In the case of support-legs out of the plane of symmetry, the worst case shall be selected by the Technical Service for the test.
- (c) In the case of "~~①~~ **Size-integral** specific vehicle **ISOFIX**" category, the support-leg shall be adjusted as specified by the Child Restraint System manufacturer.

- (d) The leg length of a support-leg must be adjustable in such a way that it is able to cover the complete span of floor pan levels that are allowed for in Regulation No. 16, Annex 17 for car seats to be approved for the installation -Size Child Restraints Systems.
- 7.1.3.6.4. The test specified in paragraph 6.6.4.1.6.2. need only be carried out with the largest manikin for which the child restraint is designed.
- 7.2. Tests of individual components
- 7.2.1. Buckle
- 7.2.1.1. Opening test under load
- 7.2.1.1.1. A child restraint already having been subjected to the dynamic test specified in paragraph 7.1.3. shall be used for this test.
- 7.2.1.1.2. The child restraint shall be removed from the test trolley or the vehicle without opening the buckle. A tension of 200 ± 2 N shall be applied to the buckle. If the buckle is attached to a rigid part, the force shall be applied reproducing the angle formed between the buckle and that rigid part during the dynamic test.
- 7.2.1.1.3. A load shall be applied at a speed of 400 ± 20 mm/min to the geometric centre of the buckle-release button along a fixed axis running parallel to the initial direction of motion of the button; the geometric centre applies to that part of the surface of the buckle to which the release pressure is to be applied. The buckle shall be secured against a rigid support during the application of the opening force.
- 7.2.1.1.4. The buckle opening force shall be applied, using a dynamometer or similar device in the manner and direction of normal use. The contact end shall be a polished metal hemisphere with radius 2.5 ± 0.1 mm.
- 7.2.1.1.5. The buckle opening force shall be measured and any failure noted.
- 7.2.1.2. Opening test under zero load
- 7.2.1.2.1. A buckle assembly which has not previously been subjected to a load shall be mounted and positioned under a "no load" condition.
- 7.2.1.2.2. The method of measuring the buckle opening force shall be as prescribed in paragraphs 7.2.1.1.3. and 7.2.1.1.4.
- 7.2.1.2.3. The buckle opening force shall be measured.
- 7.2.1.3. Strength test
- 7.2.1.3.1. For the strength test two samples have to be used. All adjusters, except for adjusters mounted directly on a child restraint are included in the test.
- 7.2.1.3.2. Annex 17 shows a typical device for a buckle strength test. The buckle is placed on the upper round plate (A) within the relief. All adjacent straps have a length of at least 250 mm and are arranged hanging down from the upper plate respective to their position at the buckle. The free strap ends are then wound round the lower round plate (B) until they come out at the plate's inner opening. All straps have to be vertical between A and B. The round clamping plate (C) is then lightly clamped against the lower face of (B), still allowing a certain strap movement between them. With a small force at the tensile machine the straps are tensioned and pulled between (B) and (C) until all straps are loaded respective to their arrangement. The buckle must stay free

from plate (A) or any parts at (A) during this operation and the test itself. (B) and (C) are then clamped firmly together and the tensile force is increased at a traverse speed of 100 ± 20 mm/min until the required values are reached.

- 7.2.2. Adjusting device
- 7.2.2.1. Ease of adjustment
- 7.2.2.1.1. When testing a manual adjusting device, the strap shall be drawn steadily through the adjusting device, having regard for the normal conditions of use, at a rate of 100 ± 20 mm/min and the maximum force measured to the nearest integer value of N after the first 25 ± 5 mm of strap movement.
- 7.2.2.1.2. The test shall be carried out in both directions of strap travel through the device, the strap being subjected to the full travel cycle 10 times prior to the measurement.
- 7.2.3. Microslip test (see Annex 5, figure 3)
- 7.2.3.1. The components or devices to be subjected to the microslip test shall be kept for a minimum of 24 hours before testing in an atmosphere having a temperature of $20 \pm 5^\circ\text{C}$ and a relative humidity of 65 ± 5 per cent. The test shall be carried out at a temperature between 15 and 30°C .
- 7.2.3.2. The free end of the strap shall be arranged in the same configuration as when the device is in use in the vehicle, and shall not be attached to any other part.
- 7.2.3.3. The adjusting device shall be placed on a vertical piece of strap one end of which bears a load of 50 ± 0.5 N (guided in a manner which prevents the load from swinging and the strap from twisting). The free end of the strap from the adjusting device shall be mounted vertically upwards or downwards as it is in the vehicle. The other end shall pass over a deflector roller with its horizontal axis parallel to the plane of the section of strap supporting the load, the section passing over the roller being horizontal.
- 7.2.3.4. The device being tested shall be arranged in such a way that its centre, in the highest position to which it can be raised, is 300 ± 5 mm from a support table, and the load of 50 N shall be 100 ± 5 mm from that support table.
- 7.2.3.5. 20 ± 2 pre-test cycles shall then be completed and $1,000 \pm 5$ cycles shall then be completed at a frequency of 30 ± 10 cycles per minute, the total amplitude being 300 ± 20 mm or as specified in paragraph 7.2.5.2.6.2. The 50 N load shall be applied only during the time corresponding to a shift of 100 ± 20 mm for each half period. Microslip shall be measured from the position at the end of the 20 pre-test cycles.
- 7.2.4. Retractor
- 7.2.4.1. Retracting force
- 7.2.4.1.1. The retracting forces shall be measured with the safety belt assembly, fitted to a manikin as for the dynamic test prescribed in paragraph 7.1.3. The strap tension shall be measured at the point of contact with (but just clear of) the manikin while the strap is being retracted at the approximate rate of 0.6 m/min.
- 7.2.4.2. Durability of retractor mechanism
- 7.2.4.2.1. The strap shall be withdrawn and allowed to retract for the required number of cycles at a rate of not more than 30 cycles per minute. In the case of emergency-locking retractors, a jolt to lock the retractor shall be introduced

at each fifth cycle. The jolts occur in equal numbers at each of five different extractions, namely, 90, 80, 75, 70 and 65 per cent of the total length of the strap on the retractor. However, where the length of the strap exceeds 900 mm the above percentage shall be related to the final 900 mm of strap which can be withdrawn from the retractor.

- 7.2.4.3. Locking of emergency-locking retractors
- 7.2.4.3.1. The retractor shall be tested once for locking, when the strap has been unwound to its full length less 300 ± 3 mm.
- 7.2.4.3.2. In the case of a retractor actuated by strap movement, the extraction shall be in the direction in which it normally occurs when the retractor is installed in a vehicle.
- 7.2.4.3.3. When retractors are being tested for sensitivity to vehicle accelerations, they shall be tested at the above extraction length in both directions along two mutually perpendicular axes which are horizontal if the retractors are to be installed in a vehicle as specified by the child restraint manufacturer. When this position is not specified, the testing authority shall consult the child restraint manufacturer. One of these test directions shall be chosen by the Technical Service conducting the approval tests to give the most adverse conditions with respect to actuation of the locking mechanism.
- 7.2.4.3.4. The design of the apparatus used shall be such that the required acceleration is given at an average rate of increase of acceleration of at least 25 g/s.⁵
- 7.2.4.3.5. For testing compliance with the requirements of paragraphs 6.7.3.2.1.3. and 6.7.3.2.1.4. the retractor shall be mounted on a horizontal table and the table tilted at a speed not exceeding 2° per second until locking has occurred. The test shall be repeated with tilting in other directions to ensure that the requirements are fulfilled.
- 7.2.4.4. Corrosion test
- 7.2.4.4.1. The corrosion test is described in paragraph 7.1.1. above.
- 7.2.4.5. Dust resistance test
- 7.2.4.5.1. The retractor shall be positioned in a test chamber as described in Annex 3 to this Regulation. It shall be mounted in an orientation similar to that in which it is mounted in the vehicle. The test chamber shall contain dust as specified in paragraph 7.2.4.5.2. below. A length of 500 mm of the strap shall be extracted from the retractor and kept extracted, except that it shall be subjected to 10 complete cycles of retraction and withdrawal within one or two minutes after each agitation of the dust. For a period of five hours, the dust shall be agitated every 20 minutes for five seconds by compressed air free of oil and moisture at a gauge pressure of 5.5 ± 0.5 bars entering through an orifice 1.5 ± 0.1 mm in diameter.
- 7.2.4.5.2. The dust used in the test described in paragraph 7.2.4.5.1. shall consist of about 1 kg of dry quartz. The particle size distribution shall be as follows:
- (a) passing 150 µm aperture, 104 µm wire diameter: 99 to 100 per cent;
 - (b) passing 105 µm aperture, 64 µm wire diameter: 76 to 86 per cent;

⁵ g = 9.81 m/s².

- (c) passing 75 µm aperture, 52 µm wire diameter: 60 to 70 per cent.
- 7.2.5. Static test for straps
 - 7.2.5.1. Strap strength test
 - 7.2.5.1.1. Each test shall be carried out on two new samples of strap, conditioned as specified in paragraph 6.7.4.
 - 7.2.5.1.2. Each strap shall be gripped between the clamps of a tensile strength-testing machine. The clamps shall be so designed as to avoid breakage of the strap at or near them. The speed of traverse shall be 100 ± 20 mm/min. The free length of the specimen between the clamps of the machine at the start of the test shall be $200 \text{ mm} \pm 40 \text{ mm}$.
 - 7.2.5.1.2.1. The tension shall be increased until the strap breaks and the breaking load noted.
 - 7.2.5.1.3. If the strap slips or breaks at or within 10 mm of either of the clamps, the test shall be invalid and a new test shall be carried out on another specimen.
 - 7.2.5.2. Samples out from straps, as referred to in paragraph 3.2.3., shall be conditioned as follows:
 - 7.2.5.2.1. Room conditioning
 - 7.2.5.2.1.1. The strap shall be kept for 24 ± 1 hours in an atmosphere having a temperature of $23 \pm 5^\circ \text{C}$ and a relative humidity of 50 ± 10 per cent. If the test is not carried out immediately after conditioning, the specimen shall be placed in a hermetically closed receptacle until the test begins. The breaking load shall be determined within five minutes after removal of the strap from the conditioning atmosphere or from the receptacle.
 - 7.2.5.2.2. Light conditioning
 - 7.2.5.2.2.1. The provisions of Recommendation ISO/105-B02 (1978), shall apply. The strap shall be exposed to light for the time necessary to produce fading of Standard Blue Dye No. 7 to a contrast equal to Grade 4 on the grey scale.
 - 7.2.5.2.2.2. After exposure, the strap shall be kept for a minimum of 24 hours in an atmosphere having a temperature of $23^\circ \pm 5^\circ \text{C}$ and a relative humidity of 50 ± 10 per cent. The breaking load shall be determined within five minutes after the removal of the strap from the conditioning installation.
 - 7.2.5.2.3. Cold conditioning
 - 7.2.5.2.3.1. The strap shall be kept for a minimum of 24 hours in an atmosphere having a temperature of $23 \pm 5^\circ \text{C}$ and a relative humidity of 50 ± 10 per cent.
 - 7.2.5.2.3.2. The strap shall then be kept for 90 ± 5 minutes on a plain surface in a low-temperature chamber in which the air temperature is $-30 \pm 5^\circ \text{C}$. It shall then be folded and the fold shall be loaded with a weight of 2 ± 0.2 kg previously cooled to $-30 \pm 5^\circ \text{C}$. When the strap has been kept under load for 30 ± 5 minutes in the same low-temperature chamber, the weight shall be removed and the breaking load shall be measured within five minutes after removal of the strap from the low-temperature chamber.
 - 7.2.5.2.4. Heat conditioning
 - 7.2.5.2.4.1. The strap shall be kept for 180 ± 10 minutes in a heating-cabinet atmosphere having a temperature of $60 \pm 5^\circ \text{C}$ and a relative humidity 65 ± 5 per cent.

- 7.2.5.2.4.2. The breaking load shall be determined within five minutes after removal of the strap from the heating cabinet.
- 7.2.5.2.5. Exposure to water
 - 7.2.5.2.5.1. The strap shall be kept fully immersed for 180 ± 10 minutes in distilled water, at a temperature of 20 ± 5 °C, to which a trace of wetting agent has been added. Any wetting agent suitable for the fibre being tested may be used.
 - 7.2.5.2.5.2. The breaking load shall be determined within 10 minutes after removal of the strap from the water.
- 7.2.5.2.6. Abrasion conditioning
 - 7.2.5.2.6.1. The components or devices to be submitted to the abrasion test shall be kept for a minimum of 24 hours before testing in an atmosphere having a temperature of 23 ± 5 °C and a relative humidity of 50 ± 10 per cent. The room temperature during the testing shall be between 15° and 30 °C.
 - 7.2.5.2.6.2. The table below sets out the general conditions for each test:

Table 8

	<i>Load (N)</i>	<i>Cycles per minute</i>	<i>Cycles (No.)</i>
Type 1 procedure	10 ± 0.1	30 ± 10	$1,000 \pm 5$
Type 2 procedure	5 ± 0.05	30 ± 10	$5,000 \pm 5$

Where there is insufficient strap to test over 300 mm of shift, the test may be applied over a shorter length subject to a minimum of 100 mm.

- 7.2.5.2.6.3. Particular test conditions
 - 7.2.5.2.6.3.1. Type 1 procedure: for cases where the strap slides through the quick adjusting device. The 10 N load shall be vertically and permanently applied on one of the straps. The other strap, set horizontally, shall be attached to a device, giving the webbing a back and forth motion. The adjusting device shall be so placed that the horizontal strap of the webbing remains under tension (see Annex 5, figure 1).
 - 7.2.5.2.6.3.2. Type 2 procedure: for cases where the strap changes direction in passing through a rigid part. During this test, the angles of both webbing straps shall be as shown in Annex 5, figure 2. The 5 N load shall be permanently applied. For cases where the strap changes direction more than once in passing through a rigid part, the load of 5 N may be increased so as to achieve the prescribed 300 mm of strap movement through that rigid part.
- 7.2.6. Conditioning test for adjusters mounted directly on a child restraint

Install the largest ~~dummy~~ **manikin** for which the restraint is intended, as if for the dynamic test, including the standard slack as specified in paragraph 7.1.3.5. Mark a reference line on the webbing where the free end of the webbing enters the adjuster.

Remove the ~~dummy~~ **manikin** and place the restraint in the conditioning rig shown in figure 1, Annex 16.

The webbing must be cycled for a total distance of not less than 150 mm through the adjuster. This movement shall be such that at least 100 mm of

webbing on the side of the reference line towards the free end of the webbing and the remainder of the moving distance (approx. 50 mm) on the integral harness side of the reference line moves through the adjuster.

If the length of webbing from the reference line to the free end of the webbing is insufficient for the movement described above, the 150 mm of movement through the adjuster shall be from the fully extended harness position.

The frequency of cycling shall be 10 ± 1 cycles/minute, with a velocity on "B" of 150 ± 10 mm/sec.

7.2.7. Temperature test

7.2.7.1. The components specified in paragraph 6.6.5.1. shall be exposed to an environment over a water surface within a closed space, the environment having a temperature of not less than 80 °C, for a continuous period of not less than 24 hours and then cooled in an environment having a temperature not exceeding 23°C. The cooling period shall immediately be followed by three consecutive 24 hour cycles with each cycle comprising the following consecutive sequences:

- (a) an environment having a temperature of not less than 100°C shall be maintained for a continuous period of 6 hours and this environment shall be attained within 80 minutes of commencement of the cycle; then
- (b) an environment having a temperature of not more than 0°C shall be maintained for a continuous period of 6 hours and this environment shall be attained within 90 minutes; then
- (c) an environment having a temperature of not more than 23°C shall be maintained during the remainder of the 24 hour cycle.

7.3. Certification of Test Bench Cushion

[Remark: the contents of paragraph 7.3. will be replaced by the certification derived from the work done by NPACS.]

[7.3.1. The test **bench** seat cushion shall be certified when new to establish initial values for impact penetration and peak deceleration, and then after every 50 dynamic tests or at least every month, whichever is the sooner, or before each test if the test rig is used frequently.

7.3.2. The certification and measuring procedures shall correspond to those specified in the latest version of ISO 6487; the measuring equipment shall correspond to the specification of a data channel with a channel filter class (CFC) 60.

Using the test device defined in Annex 14 to this Regulation, conducts 3 tests, 150 ± 5 mm from the front edge of the cushion on the centre line and at 150 ± 5 mm in each direction from the centre line.

Place the device vertically on a flat rigid surface. Lower the impact mass until it contacts the surface and set the penetration marker to the zero position. Place the device vertically above the test point, raise the mass 500 ± 5 mm and allow it to fall freely to make impact on the **test bench** seat **cushion** surface. Record the penetration and the deceleration curve.

- 7.3.3. The peak values recorded shall not deviate by more than 15 per cent from the initial values.]
- 7.4. Registration of dynamic behaviour
- 7.4.1. In order to determine the behaviour of the manikin and its displacements, all dynamic tests shall be registered according to the following conditions:
 - 7.4.1.1. Filming and recording conditions:
 - (a) The frequency shall be at least 1000 frames per second;
 - (b) the test shall be recorded on video or digital data carrier over at least the first 300 ms.
 - 7.4.1.2. Estimation of uncertainty:

Testing laboratories shall have and shall apply procedures for estimating uncertainty of measurement of the displacement of the manikin's head. The uncertainty shall be within ± 25 mm.

Examples of international standards of such procedure are EA-4/02 of the European Accreditation Organization or ISO 5725:1994 or the General Uncertainty Measurement (GUM) method.
- 7.5. The measuring procedures shall correspond to those defined in **the latest version** of ISO 6487: 2002. The channel frequency class shall be:

Table 9

<i>Type of measurement</i>	<i>CFC(F_H)</i>	<i>Cut-off frequency (F_N)</i>
Trolley acceleration	600	see ISO 6487:2002 Annex A
Belt loads	600	see ISO 6487:2002 Annex A
Chest acceleration	600	see ISO 6487:2002 Annex A
Head acceleration	1000	[1650]
Upper neck force	600	
Upper neck moment	600	
Chest deflection	600	

The sampling rate should be a minimum of 10 times the channel frequency class (i.e. in installations with channel frequency class of 1000, this corresponds to a minimum sampling rate of 10000 samples per second per channel).

8. Test Reports of Type Approval and of Production Qualification

- 8.1. The test report shall record the results of all tests and measurements including the following test data:
 - (a) the type of device used for the test (acceleration or deceleration device);
 - (b) the total velocity change;
 - (c) the trolley speed immediately before impact only for deceleration sleds;

- (d) the acceleration or deceleration curve during all the velocity change of the trolley and at least 300 ms;
- (e) the time (in ms) when the head of the manikin reaches its maximum displacement during the performance of the dynamic test;
- (f) the place occupied by the buckle during the tests, if it can be varied;
- (g) any failure or breakage;
- (h) the following ~~dummy~~ **manikin** criteria: HIC, Head Acceleration 3ms, Upper Neck Tension Force, Upper Neck Moment, Thorax Chest Deflection and Lower Lumbar Load Cell Force; and
- (i) the lap belt force.

Remark: the list of data above could be replaced by the requirement that the test report must be formulated according a harmonized test report given in Annex [X].

- 8.2. If provisions relating to anchorages contained in Annex 6, Appendix 3, to this Regulation have not been respected, the test report shall describe how the child restraint is installed and shall specify important angles and dimensions.
- 8.3. When the child restraint is tested in a vehicle or vehicle structure, the test report shall specify the manner of attaching the vehicle structure to the trolley, the position of the ~~Child Restraint~~ **Child Restraint System** and vehicle seat and the inclination of the vehicle seat-back.
- 8.4. The test reports of type approval and of production qualification shall record the verification of markings and of instructions on installation and use.

9. Production Qualification

- 9.1. In order to make sure that the manufacturer's production system is satisfactory, the Technical Service, which conducted the type approval tests, must carry out tests to qualify production in accordance with paragraph 9.2.

- 9.2. Qualifying the production of Child Restraint Systems

The production of each new approved type of Child Restraint System must be subjected to production qualification tests.

For this purpose, a random sample of 5 Child Restraint Systems will be taken from the first production batch.

The first production batch is considered to be the production of the first block containing a minimum of 50 Child Restraint Systems and a maximum of 5.000 Child Restraint Systems.

- 9.2.1. Dynamic tests for frontal and rear impact
 - 9.2.1.1. Five Child Restraint Systems must be subjected to the dynamic test described in paragraph 7.1.3. The Technical Service that conducted the type approval tests shall choose the conditions that produced the maximum horizontal head excursion during the type approval dynamic tests, excluding the conditions described in paragraph 6.6.4.1.6.2. above. All the five Child Restraint Systems shall be tested under the same conditions.

- 9.2.1.2. For each test described in paragraph 9.2.1.1., the injury criteria described in paragraph 6.6.4.3.1.; and
for forward facing the head excursion described in paragraph 6.6.4.4.1.1.;
for rearward facing and carrycots the head exposure described in paragraph 6.6.4.4.1.2.1. and head excursion described in 6.6.4.4.1.2.2.;
shall be measured.
- 9.2.1.3. The maximum head excursion results shall comply with the following two conditions:
- 9.2.1.3.1. No value shall exceed 1.05 L, and
X + S shall not exceed L
Where: L = the limit value prescribed
X = the mean of the values
S = the standard deviation of the values.
- 9.2.1.3.2. The injury criteria results shall comply with the requirements of paragraph 6.6.4.3.1. and, in addition, the X + S condition in paragraph 9.2.1.3.1. shall be applied to the 3 ms clipped injury criteria results (as defined in paragraph 6.6.4.3.1.) and recorded for information only.
- 9.2.2. Dynamic tests for lateral impact
- 9.2.3. Control of Markings
- 9.2.3.1. The Technical Service that conducted the approval tests shall verify that the markings conform to the requirements of paragraph 4.
- 9.2.3.2. Control of Instructions on Installation and the Instructions for Use.
- 9.2.3.3. The Technical Service that conducted the approval tests shall verify that the instructions on installation and the instructions for use conform to paragraph 14.

10. Conformity of Production and Routine Tests

The conformity of production procedures shall comply with those set out in the Agreement, Appendix 2 (E/ECE/324-E/ECE/TRANS/505/Rev.2), with the following requirements:

- 10.1. Any Child Restraint System approved to this Regulation shall be so manufactured as to conform to the type approved by meeting the requirements set forth in paragraphs 6. to 7. above.
- 10.2. The minimum requirements for conformity of production control procedures set forth in Annex 13 to this Regulation shall be complied with.
- 10.3. The authority which has granted type approval may at any time verify the conformity control methods applied in each production facility. The normal frequency of these verifications shall be twice a year.

11. Modification and extension of Approval of a Child Restraint System

- 11.1. Every modification of a child restraint shall be notified to the administrative department which approved the child restraint. The department may then either:
- 11.1.1. consider that the modifications made are unlikely to have an appreciable adverse effect and that in any case the child restraint still complies with the requirements; or
- 11.1.2. require a further test report from the Technical Service responsible for conducting the tests.
- 11.2. Confirmation or refusal of approval, specifying the alterations, shall be communicated by the procedure specified in paragraph 5.3. above to the Parties to the Agreement applying this Regulation.
- 11.3. The competent authority issuing the extension of approval shall assign a series number for such an extension and inform thereof the other Parties to the 1958 Agreement applying this Regulation by means of a communication form conforming to the model in Annex 1 to this Regulation.

12. Penalties for Non-Conformity of Production

- 12.1. The approval granted in respect of a child restraint pursuant to this Regulation may be withdrawn if a child restraint bearing the particulars referred to in paragraph 5.4. fails to pass the random checks described in paragraph 9. or does not conform to the type approved.
- 12.2. If a Party to the Agreement which applies this Regulation withdraws an approval it has previously granted, it shall forthwith so notify the other Contracting Parties applying this Regulation by means of a communication form conforming to the model in Annex 1 to this Regulation.

13. Production Definitely Discontinued

- 13.1. If the holder of the approval completely ceases to manufacture a specific type of child restraint under this Regulation, he shall inform thereof the authority which granted the approval. Upon receiving the relevant communication, that authority shall inform the other Parties to the Agreement which apply this Regulation by means of a communication form conforming to the model in Annex 1 to this Regulation.

14. Information for Users

- 14.1. Each child restraint shall be accompanied by instructions in the language of the country where the device is sold with the following content:
- 14.2. Instructions on installation shall include the following points:
- 14.2.1. For “-Size” category Child Restraint Systems the following label shall be clearly visible at the point of sale without removing the packing:

Notice

This is a “**i**-Size” Child Restraint System. It is approved to Regulation [No. X], for ~~general use in vehicles and it will fit all~~, “**i**-Size compatible” vehicle ~~car seats~~. **seating positions as indicated by vehicle manufacturers in the vehicle users’ manual.**

A ~~correct~~ **Child Restraint System will fit is likely in at least one of the ISOFIX positions detailed in the vehicle handbook**, if the vehicle manufacturer has declared that the vehicle is “**i**-Size compatible” ~~in the ISOFIX positions detailed in the vehicle handbook.~~”.

This Child Restraint System has been classified as “**i**-Size” under more stringent conditions than those which applied to earlier designs which do not carry this notice.

If in doubt, consult either the child restraint manufacturer or the retailer.

- 14.2.2. for “**i**-Size Specific vehicle” category Child Restraint Systems information on the applicable vehicle shall be clearly visible at the point of sale without removing the packing;
- 14.2.3. the child restraint manufacturer shall provide information on the packing box as to the address to which the customer can write to obtain further information on fitting the child restraint in specific cars;
- 14.2.4. the method of installation illustrated by photographs and/or very clear drawings;
- 14.2.5. the user shall be advised that the rigid items and plastic parts of a child restraint must be so located and installed that they are not liable, during everyday use of the vehicle, to become trapped by a movable seat or in a door of the vehicle;
- 14.2.6. the user should be advised to use carry-cots perpendicular to the longitudinal axis of the vehicle;
- 14.2.7. in the case of rearward facing Child Restraint Systems the customer shall be advised not to use them in seating positions where there is an airbag installed. This information shall be clearly visible at the point of sale without removing the packaging;
- 14.2.8. for “**i**-Size Special Needs Restraints” the following information shall be clearly visible at the point of sale without removing the packing:

This “**i**-Size Special Needs Restraint” is designed to give extra support to children who have difficulty in sitting correctly in conventional seats. Always consult your doctor to make sure that this restraint system is suitable for your child.

- 14.3. The instructions for use shall include the following points:
 - 14.3.1. The “Size range” and the maximum occupant mass for which the device is intended;
 - 14.3.2. the method of use shall be shown by photographs and/or very clear drawings. In the case of seats that can be used both forward and rearward facing, clear warning must be given to keep the Child Restraint System rearward facing until the child’s age is greater than a stated limit, or some other dimensional criterion is exceeded;

- 14.3.3. the operation of the buckle and adjusting devices shall be explained clearly;
- 14.3.4. it shall be recommended that any straps holding the restraint to the vehicle should be tight, that any support-leg should be in contact with the vehicle floor, that any straps restraining the child should be adjusted to the child's body, and that straps should not be twisted;
- 14.3.5. the importance of ensuring that any lap strap is worn low down, so that the pelvis is firmly engaged, shall be stressed;
- 14.3.6. it shall be recommended that the device should be ~~changed~~ **replaced** when it has been subject to violent stresses in an accident;
- 14.3.7. instructions for cleaning shall be given;
- 14.3.8. a general warning shall be given to the user concerning the danger of making any alterations or additions to the device without the approval of the competent authority, and a danger of not following closely the installation instructions provided by the child restraint manufacturer;
- 14.3.9. when the chair is not provided with a textile cover, it shall be recommended that the chair should be kept away from sunlight, otherwise it may be too hot for the child's skin;
- 14.3.10. it shall be recommended that children are not left in their Child Restraint System unattended;
- 14.3.11. it shall be recommended that any luggage or other objects liable to cause injuries in the event of a collision shall be properly secured.
- 14.3.12. It shall be recommended that:
- 14.3.12.1. the Child Restraint System must not be used without the cover;
- 14.3.12.2. the **Child Restraint System seat** cover should not be replaced with any other than the one recommended by the manufacturer, because the cover constitutes an integral part of the restraint performance.
- 14.3.13. There shall be provisions made so that the instructions can be retained on the child restraint for its life period or in the vehicle handbook in the case of built-in restraints.
- 14.3.14. For an **Ⓢ**-Size Child Restraint System, the instruction for use must be given to read the car manufacturer's handbook.

15. Transitional Provisions

- 15.1. As from the date of entry into force of this Regulation, Contracting Parties applying this Regulation shall not:
- (a) Refuse to grant ECE approval for a type of Child Restraint System under this Regulation; or
- (b) Prohibit the sale or entry into service of a Child Restraint System
- if the Child Restraint System falls within the scope of this Regulation and complies with the requirements of this Regulation.

16. Names and Addresses of Technical Services Responsible for Conducting Approval Tests, and of Administrative Departments

The Parties to the 1958 Agreement applying this Regulation shall communicate to the United Nations Secretariat the names and addresses of the technical services responsible for conducting approval tests and of the administrative departments which grant approval and to which forms certifying approval or extension or refusal or withdrawal of approval, or production definitely discontinued, issued in other countries, are to be sent.

Formatted: English U.S.

Annexes

Annex 1

Communication

(Maximum format: A4 (210 x 297 mm))

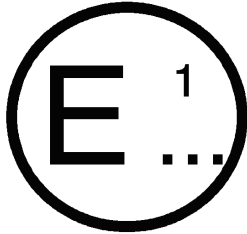

issued by:

Name of administration:

.....

- concerning: ²
- APPROVAL GRANTED
 - APPROVAL EXTENDED
 - APPROVAL REFUSED
 - APPROVAL WITHDRAWN
 - PRODUCTION DEFINITELY DISCONTINUED

of restraining devices for child occupants of power-driven vehicles, pursuant to Regulation No. 44.

Approval No.: Extension No.:

- [1.1. Forward-facing child restraint/rearward-facing child restraint/carry-cot;
- 1.2. Integral/~~non-integral~~ /partial/booster cushion;
- 1.3. Belt type:
 - (adult) three-point belt
 - (adult) lap belt/
 - special type belt/retractor;]
- 1.4. Other features: chair assembly/impact shield
- 2. Trade name or mark
- 3. Manufacturer's designation of the child restraint

¹ Distinguishing number of the country which has granted/extended/refused/withdrawn approval (see approval provisions in the Regulation).

² Strike out what does not apply.

4. Manufacturer's name
5. If applicable, name of his representative
6. Address
7. Submitted for approval on
8. Technical Service conducting approval tests
9. Type of device: deceleration/acceleration²
10. Date of test report issued by that service
11. Number of test report issued by that service
12. Approval granted/extended/refused/withdrawn²/ for use in Groups 0, 0+, I, II or III and for universal/semi-universal/restricted use or use in a specific vehicle or for use as a "special needs restraint", position in vehicle
13. Position and nature of the marking
14. Place
15. Date
16. Signature
17. The following documents, bearing the approval number shown above, are attached to this communication:
 - (a) drawings, diagrams and plans of the child restraint, including any retractor, chair assembly, impact shield fitted;
 - (b) drawings, diagrams and plans of the vehicle structure and the seat structure, as well as of the adjustment system and the attachments, including any energy absorber fitted;
 - (c) photographs of the child restraint and/or vehicle structure and seat structure;
 - (d) instructions for fitting and use;
 - (e) list of vehicle models for which the restraint is intended.

Annex 2

Arrangements of the Approval Mark

[To be defined]

The Child Restraint System bearing the above approval mark is a device capable of being fitted in any -size compatible vehicle and of being used for the [40cm-70cm] size range and mass limit of [24kg]; it is approved in France (E2) under the number [00xxx]. The approval number indicates that the approval was granted in accordance with the requirements of the Regulation concerning the approval of ~~{ISOFIX-integral/}~~ enhanced} Child Restraint Systems used onboard of motor vehicles as amended by the 00 series of amendments.

[To be defined]

The Child Restraint System bearing the above approval mark is a device not capable of being fitted in every vehicle and of being used for the [40cm to 70cm] size range and mass limit of [24kg]; it is approved in France (E2) under the number 002450. The approval number indicates that the approval was granted in accordance with the requirements of the Regulation concerning the approval of [ISOFIX Integral/ Enhanced] Child Restraint Systems used onboard of motor vehicles as amended by the 00 series of amendments. The symbol “Y” indicates that the system contains a crotch strap.

Note: The approval number and additional symbol(s) must be placed close to the circle and either above or below the “E” or to left or right of it. The digits of the approval number must be on the same side of the “E” and oriented in the same direction. The additional symbol(s) must be diametrically opposite the approval number. The use of Roman numerals as approval numbers should be avoided so as to prevent any confusion with other symbols.

Annex 3

Arrangement of Apparatus for Dust Resistance Test

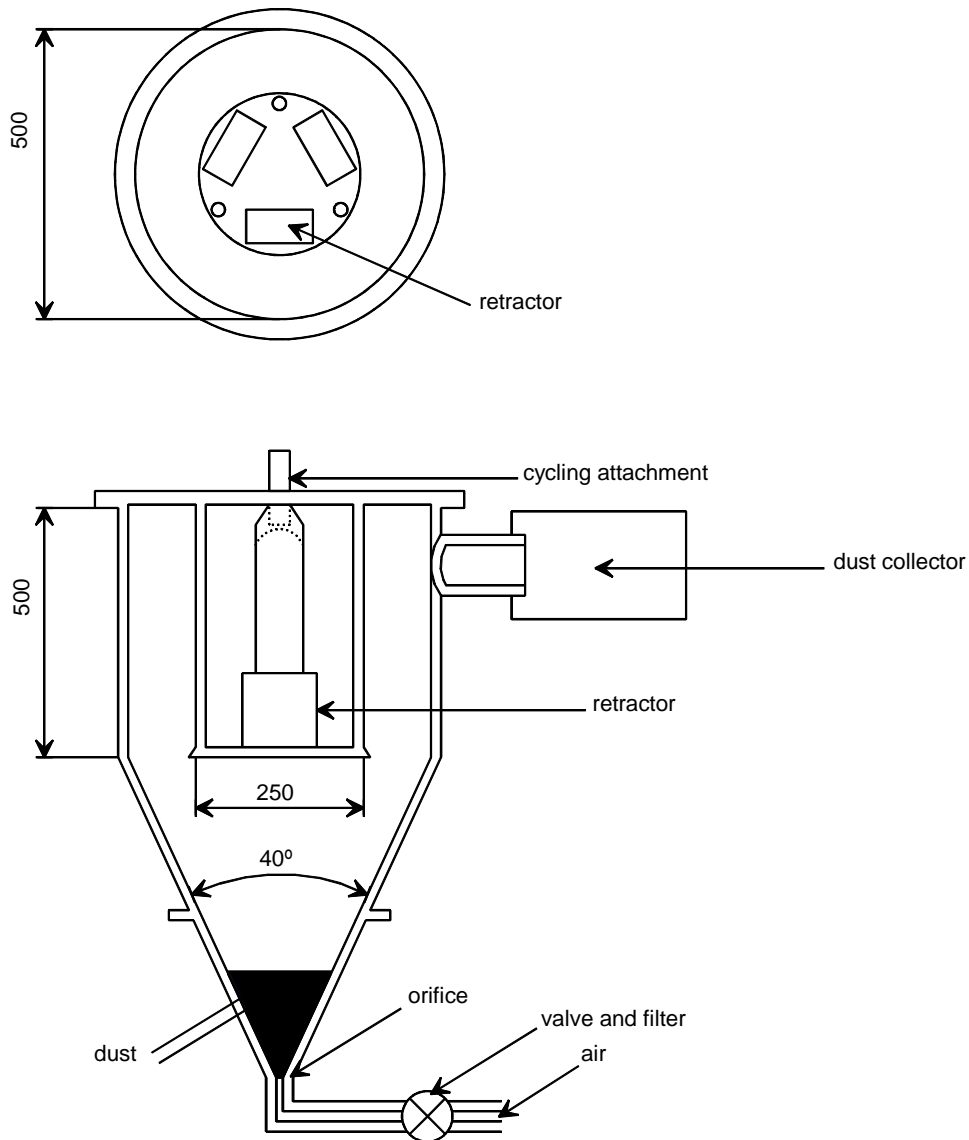

Annex 4

Corrosion Test

1. Test apparatus
 - 1.1. The apparatus shall consist of a mist chamber, a salt solution reservoir, a supply of suitably conditioned compressed air, one or more atomizing nozzles, sample supports, provision for heating the chamber, and necessary means of control. The size and detailed construction of the apparatus shall be optional, provided that the test conditions are met.
 - 1.2. It is important to ensure that drops of solution accumulated on the ceiling or cover of the chamber do not fall on test samples.
 - 1.3. Drops of solution which fall from test samples shall not be returned to the reservoir for respraying.
 - 1.4. The apparatus shall not be constructed of materials that will affect the corrosiveness of the mist.
2. Location of test samples in the mist cabinet
 - 2.1. Samples, except retractors, shall be supported or suspended between 15° and 30° from the vertical and preferably parallel to the principal direction of horizontal flow of mist through the chamber, based upon the dominant surface being tested.
 - 2.2. Retractors shall be supported or suspended so that the axes of the reel for storing the strap shall be perpendicular to the principal direction of horizontal flow of mist through the chamber. The strap opening in the retractor shall also be facing in this principal direction.
 - 2.3. Each sample shall be so placed as to permit free settling of mist on all samples.
 - 2.4. Each sample shall be so placed as to prevent salt solution from one sample dripping on to any other sample.
3. Salt solution
 - 3.1. The salt solution shall be prepared by dissolving 5 ± 1 parts by mass of sodium chloride in 95 parts of distilled water. The salt shall be sodium chloride substantially free of nickel and copper and containing not more than 0.1 per cent of sodium iodide and not more than 0.3 per cent of total impurities in the dry state.
 - 3.2. The solution shall be such that, when atomized at 35°C, the collected solution is in the pH range of 6.5 to 7.2.
4. Compressed air
 - 4.1. The compressed air supply to the nozzle or nozzles for atomizing the salt solution shall be free of oil and dirt, and maintained at a pressure between 70 kN/m² and 170 kN/m².
5. Conditions in the mist chamber

- 5.1. The exposure zone of the mist chamber shall be maintained at $35 \pm 5^{\circ}\text{C}$. At least two clean mist collectors shall be placed within the exposure zone, so that no drops of solution from the test samples or any other sources are collected. The collectors shall be placed near the test samples, one as near as possible to any nozzle and one as far as possible from all nozzles. The mist shall be such that, for each 80 cm^2 of horizontal collecting area, from 1.0 to 2.0 ml of solution per hour, when measured over an average of at least 16 hours, is collected in each collector.
- 5.2. The nozzle or nozzles shall be directed or baffled, so that the spray does not impinge directly on the test samples.

Annex 5

Abrasion and Microslip Test

Figure 1
Procedure type 1

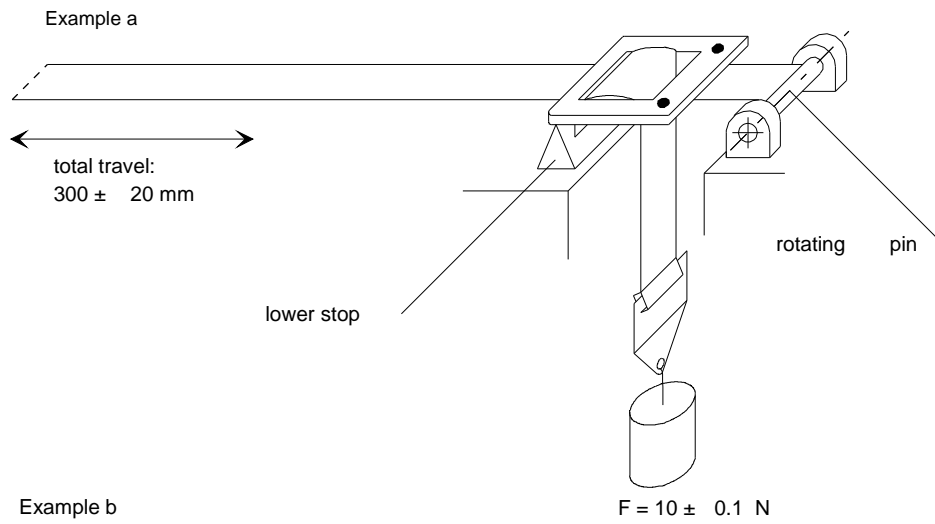
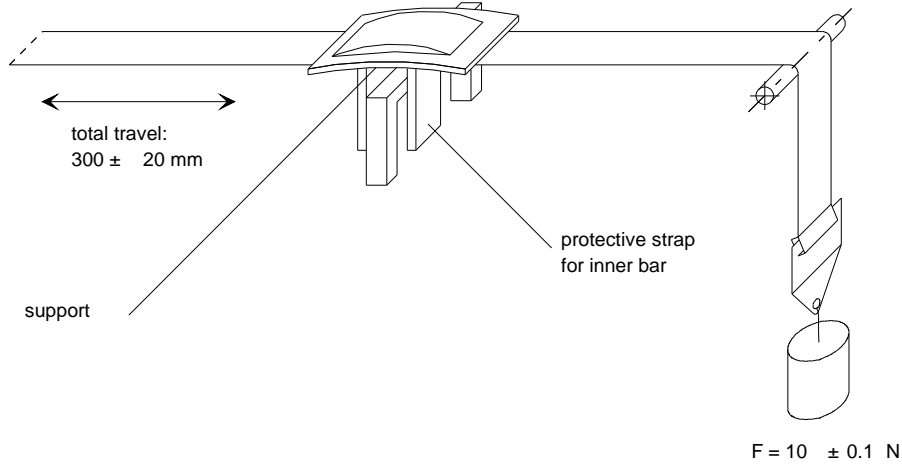

Example b
Examples of test arrangements corresponding
to the type of adjusting device

Figure 2
Procedure type 2

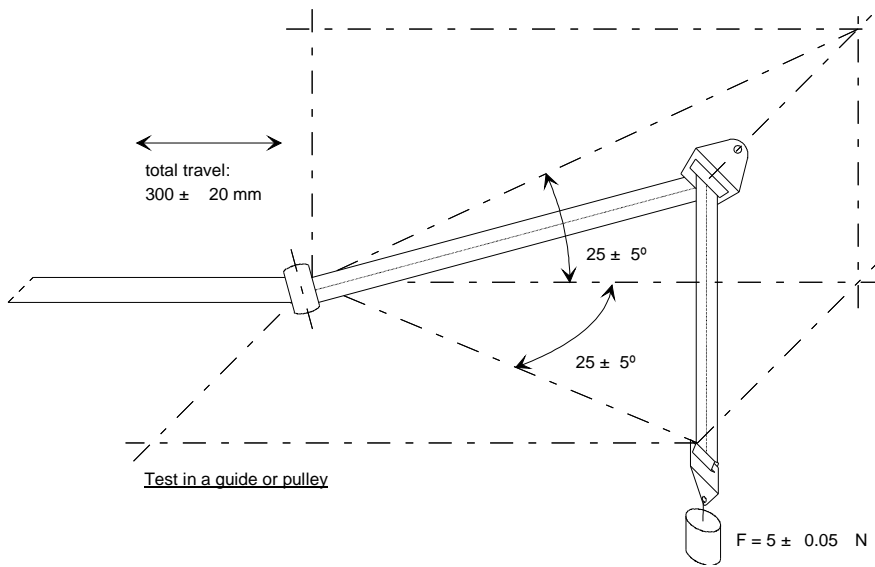
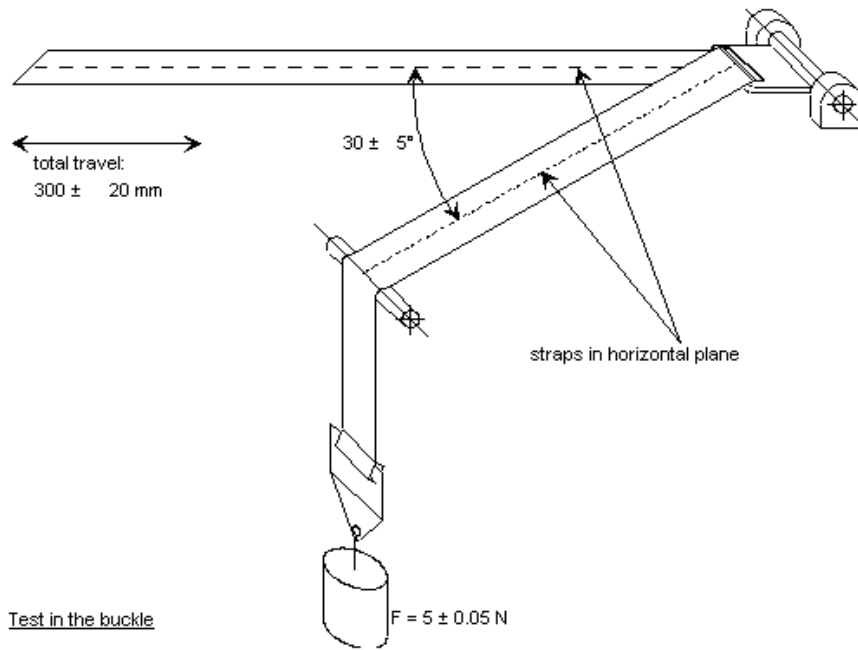
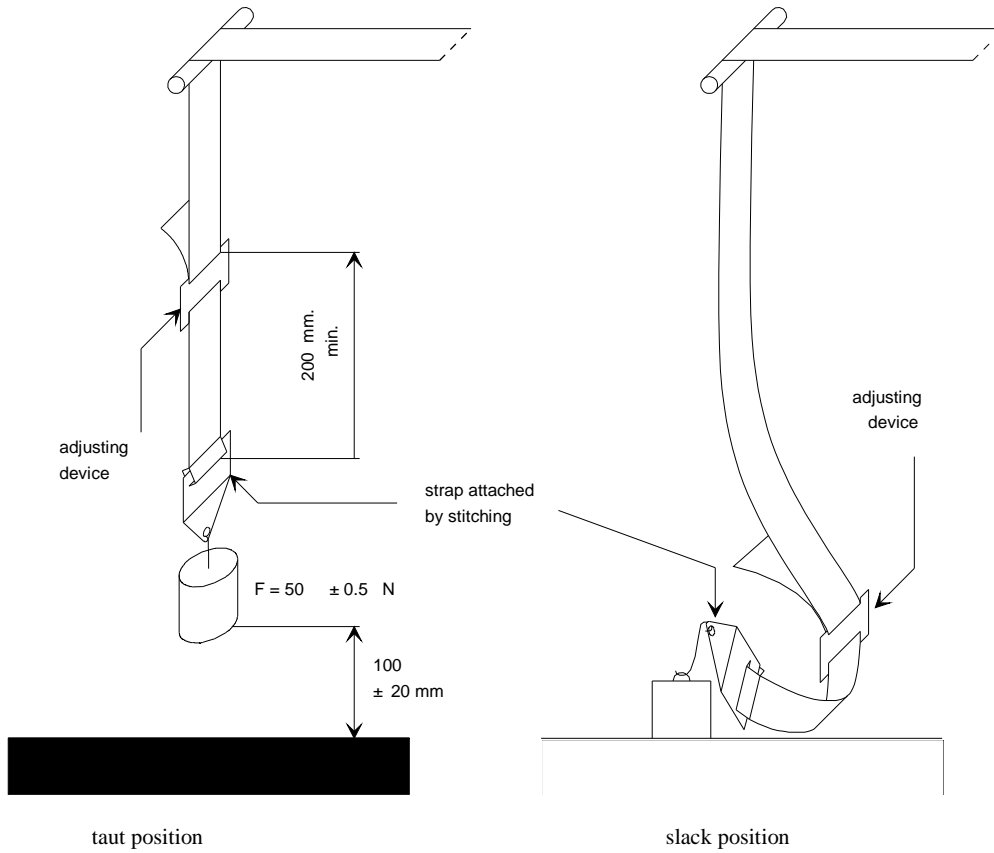

Figure 3
Microslip Test

Total travel: 300 ± 20 mm



The load of 50 N on the testing device shall be vertically guided in such a way as to prevent load-swing and twisting of the strap.

The attaching device shall be fixed to the load of 50 N in the same manner as in the vehicle.

Annex 6 [to be revised]

Description of Trolley

1. Trolley
 - 1.1. For tests on child restraints, the trolley, carrying the seat only, shall have a mass greater than 380 kg. For tests on Child Restraint Systems in the -Size ~~“vehicle-specific”~~ **“specific vehicle” ISOFIX** category, the trolley with the attached vehicle structure shall have a mass greater than 800 kg.
2. Calibration screen
 - 2.1. A calibration screen shall be attached firmly to the trolley with a movement limit line plainly marked on it to enable compliance with forward movement criteria to be determined from photographic records.
3. **Seat-Test bench**
 - 3.1. ~~The seat~~ **The test bench** shall be constructed as follows:
 - 3.1.1. a rigid back, fixed, dimensions of which are given in Appendix 1 to this annex. The lower part and the upper part are made of a 20 mm diameter tube;
 - 3.1.2. rigid seating, dimensions of which are given in Appendix 1 to this Annex. The rear part of the seating is made from a rigid sheet metal, the upper edge of which is a 20 mm diameter tube. The front part of the seating is also made of a 20 mm diameter tube;
 - 3.1.3. for access to the anchor brackets, openings shall be made at the rear of the **test bench seat** cushion ~~of the seat~~, as prescribed in Appendix 1 to this Annex;
 - 3.1.4. the width of the ~~seat~~ **test bench** shall be 800 mm;
 - 3.1.5. the back and the seating shall be covered with polyurethane foam, the characteristics of which are given in Table 1. The dimensions of the cushion are given in Appendix 1 to this annex;

Table 1

Density according to ISO 485 (kg/m ³)	43
Bearing strength according to ISO 2439B (N)	
p – 25 per cent	125
p – 40 per cent	155
Bearing strength factor according to ISO 3386 (kPa)	4
Elongation at rupture according to ISO 1798 (per cent)	180
Breaking strength according to ISO 1798 (kPa)	100
Compression set according to ISO 1856 (per cent)	3

- 3.1.6. the polyurethane foam shall be covered with a sun shade cloth, made of polyacrylate fibre, the characteristics of which are given in Table 2.

Table 2

Specific mass (g/m ²)	290
Breaking strength according to DIN 53587 on test specimen 50 mm wide:	
lengthwise (kg):	120
breadth wise (kg):	80

- 3.1.7. Covering the ~~seat~~ **test bench seat cushion** and the **test bench** seat back ¹ **cushion**
- 3.1.7.1. The **test bench seat cushion** ~~seat foam cushion~~ is produced out of a square foam block (800 x 575 x 135 mm) in such a way (see figure 1 of Appendix 1 to this Annex) that its shape resembles the shape of the aluminium bottom-plate specified in figure 2 of Appendix 1 to this Annex.
- 3.1.7.2. Six holes are drilled in the bottom-plate in order to fasten it to the trolley with bolts. The holes are drilled alongside the longest side of the plate, three on each side, their position being dependent on the construction of the trolley. Six bolts are put through the holes. It is recommended to glue the bolts on the plate with an appropriate adhesive. Afterwards, the bolts are fastened with nuts.
- 3.1.7.3. The cover material (1250 x 1200 mm, see figure 3 of Appendix 1 to this Annex) is cut across the width in such a way that it is not possible for the material to overlap after covering. There should be a gap of about 100 mm between the edges of the cover material. Therefore the material has to be cut at about 1200 mm.
- 3.1.7.4. The cover material is marked with two lines which run across the width. They are drawn 375 mm from the centreline of the cover material (see figure 3 of Appendix 1 to this Annex).
- 3.1.7.5. The **test bench seat cushion** ~~seat foam cushion~~ is placed upside down on the cover material with the aluminium bottom-plate on top.
- 3.1.7.6. On both sides the cover material is stretched until the lines drawn on it match the edges of the aluminium bottom-plate. At each bolt position, small incisions are made and the cover material is pulled over the bolts.
- 3.1.7.7. At the position of the grooves in the bottom-plate and in the foam, the cover material should be incised.
- 3.1.7.8. The cover is glued to the aluminium plate with flexible glue. The nuts have to be removed before gluing.
- 3.1.7.9. The flaps on the side are folded onto the plate and are glued as well.
- 3.1.7.10. The flaps in the grooves are folded inside and taped with a strong tape.
- 3.1.7.11. The flexible glue has to dry for at least 12 hours.

¹ Details of materials used in this process can be obtained from TNO (Research Institute for Road Vehicles), Schoemakerstraat 97, 2628 VK Delft, The Netherlands.

- 3.1.7.12. The **test bench seat-back cushion** is covered in exactly the same way as the **test bench seat cushion seat**, only the lines on the cover material (1250 x 850 mm) are drawn ~~320~~ **333** mm apart from the centreline of the material.
- 3.1.8. Line Cr is coincident with the intersection line between the top plane of the **test bench seat cushion seat** and the front lane of the **test bench seat-back cushion**.
- 3.2. Test of rearward-facing devices
- 3.2.1. A special frame shall be fitted on the trolley in order to support the child restraint **system** as shown in figure 1.
- 3.2.2. A steel tube shall be attached firmly to the trolley in such a way that a load of $5,000 \pm 50$ N applied horizontally to the centre of the tube does not cause a movement greater than 2 mm.
- 3.2.3. The dimensions of the tube shall be: 500 x 100 x 90 mm.

Figure 1
Arrangements for testing a rearward-facing device

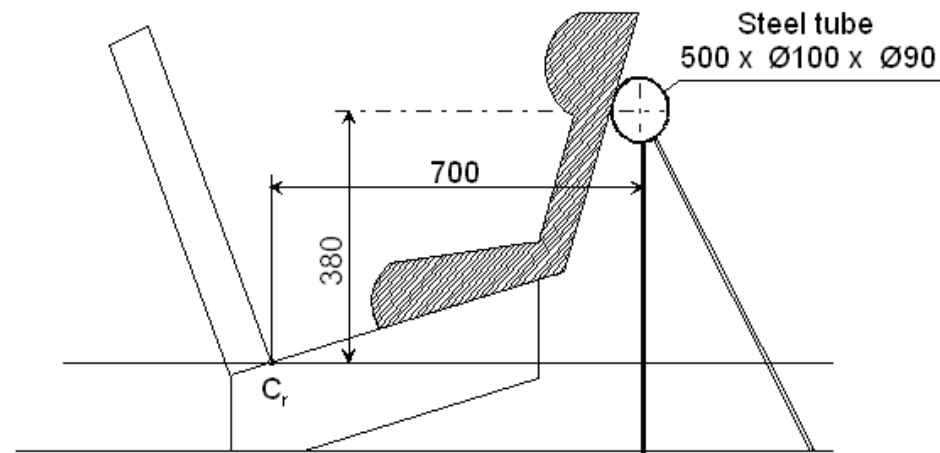

Dimension in mm

- 3.3. Trolley floor pan
- 3.3.1. The floor pan of the trolley shall be constructed of a flat sheet of metal of uniform thickness and material, see figure 2 of Appendix 3 to this Annex.
 - 3.3.1.1. The floor pan shall be rigidly mounted on the trolley. The height of the floor pan relative to the Cr axis projection point, dimension [X]² in figure 2, shall be adjusted to meet the requirements of paragraph 7.1.4.1.9.
 - 3.3.1.2. The floor pan shall be designed so that the surface hardness should not be below 120 HB, according to EN ISO 6506-1:1999.

² The dimension X shall be of 210 mm with an adjustment range of ± 70 mm.

- 3.3.1.3. The floor pan shall withstand an applied vertical concentrated load of 5 kN without causing a vertical movement greater than 2 mm referring to Cr axis and without any permanent deformation occurring.
- 3.3.1.4. The floor pan shall have a surface roughness not exceeding Ra 6,3 according to ISO 4287:1997.
- 3.3.1.5. The floor pan shall be designed so that no permanent deformation is occurring after a dynamic test of a Child Restraint System, according to this Regulation.
4. Stopping device
- 4.1. The device consists of two identical absorbers mounted in parallel.
- 4.2. If necessary, an additional absorber shall be used for each 200 kg increase in nominal mass. Each absorber shall comprise:
- 4.2.1. an outer casing formed from a steel tube;
- 4.2.2. a polyurethane energy-absorber tube;
- 4.2.3. a polished-steel olive-shaped knob penetrating into the absorber; and
- 4.2.4. a shaft and an impact plate.
- 4.3. The dimensions of the various parts of this absorber are shown in the diagram reproduced in Appendix 2 to this Annex.
- 4.4. The characteristics of the absorbing material are given in table 3 and table 4 of this Annex.
- 4.5. The stopping device assembly shall be maintained for at least 12 hours at a temperature between 15 ° and 25 °C before being used for the calibration tests described in Annex 7 to this Regulation. The stopping device shall, for each type of test, meet the performance requirements laid down in Annex 7, Appendices 1 and 2. For dynamic tests of a child restraint, the stopping device assembly shall be maintained for at least 12 hours at the same temperature, to within ± 2 °C, as that of the calibration test. Any other device giving equivalent results can be accepted.

Table 3
Characteristics of the Absorbing Material “A”³

<i>(ASTM Method 2000 (1980) unless otherwise stated)</i>	
Shore hardness A:	88 ± 2 at 20 ± 5 °C temperature
Breaking strength:	$R_o \geq 300$ kg/cm ²
Minimum elongation:	$A_o \geq 400$ per cent
Module at 100 per cent elongation:	≥ 70 kg/cm ²
Module at 300 per cent elongation:	≥ 130 kg/cm ²
Low temperature brittleness (ASTM)	5 hours at - 55 °C

³ The address to obtain the relevant ASTM standards is: ASTM, 1916 Race Street, Philadelphia, USA PA 19 103.

(ASTM Method 2000 (1980) unless otherwise stated)

Method D 736):

Compression set (Method B): 22 hours at 70 °C ≤ 45 per cent

Density at 25 °C: 1.08 to 1.12

Ageing in air (ASTM Method D 573 (1981)):

70 hours at 100 °C: Shore hardness: max. variation ± 3
 breaking strength: decrease < 10 per cent of R_o
 elongation: decrease < 10 per cent of A_o
 weight: decrease < 1 per cent

Immersion in oil (ASTM Method D 471 (1979) Oil No. 1):

70 hours at 100 °C: Shore hardness: max. variation ± 4
 breaking strength: decrease < 15 per cent of R_o
 elongation: decrease < 10 per cent of A_o
 volume: swelling < 5 per cent

Immersion in oil (ASTM Method D 471 (1979) Oil No. 3):

70 hours at 100 °C: breaking strength: decrease < 15 per cent of R_o
 elongation: decrease < 15 per cent of A_o
 volume: swelling < 20 per cent

Immersion in distilled water:

1 week at 70 °C: breaking strength: decrease < 35 per cent of R_o
 elongation: increase < 20 per cent of A_o

Table 4
Characteristics of the Absorbing Material "B"

ASTM Method 2000 (1980) unless otherwise stated

Shore hardness A:	88 ± 2 at 20 ± 5 °C temperature
Breaking strength:	R _o ≥ 300 kg/cm ²
Minimum elongation:	A _o ≥ 400 per cent
Module at 100 per cent elongation:	≥ 70 kg/cm ²
Module at 300 per cent elongation:	≥ 130 kg/cm ²
Low temperature brittleness (ASTM Method D 736):	5 hours at - 55 °C

ASTM Method 2000 (1980) unless otherwise stated

Compression set (Method B):	22 hours at 70 °C ≤ 45 per cent
Density at 25 °C:	1.08 to 1.12
Ageing in air (ASTM Method D 573 (1981)):	
70 hours at 100 °C:	Shore hardness: max. variation ± 4 breaking strength: decrease < 15 per cent of R _o elongation: decrease < 10 per cent of A _o volume: swelling < 5 per cent
Immersion in oil (ASTM Method D 471 (1979) Oil No. 3):	
70 hours at 100 °C:	breaking strength: decrease < 15 per cent of R _o elongation: decrease < 15 per cent of A _o volume: swelling < 20 per cent
Immersion in distilled water:	
1 week at 70°C	breaking strength: decrease < 35 per cent of R _o elongation: increase < 20 per cent of A _o

Annex 6

Appendix 1

Figure 1
Dimensions of the test bench seat and the test bench seat cushions

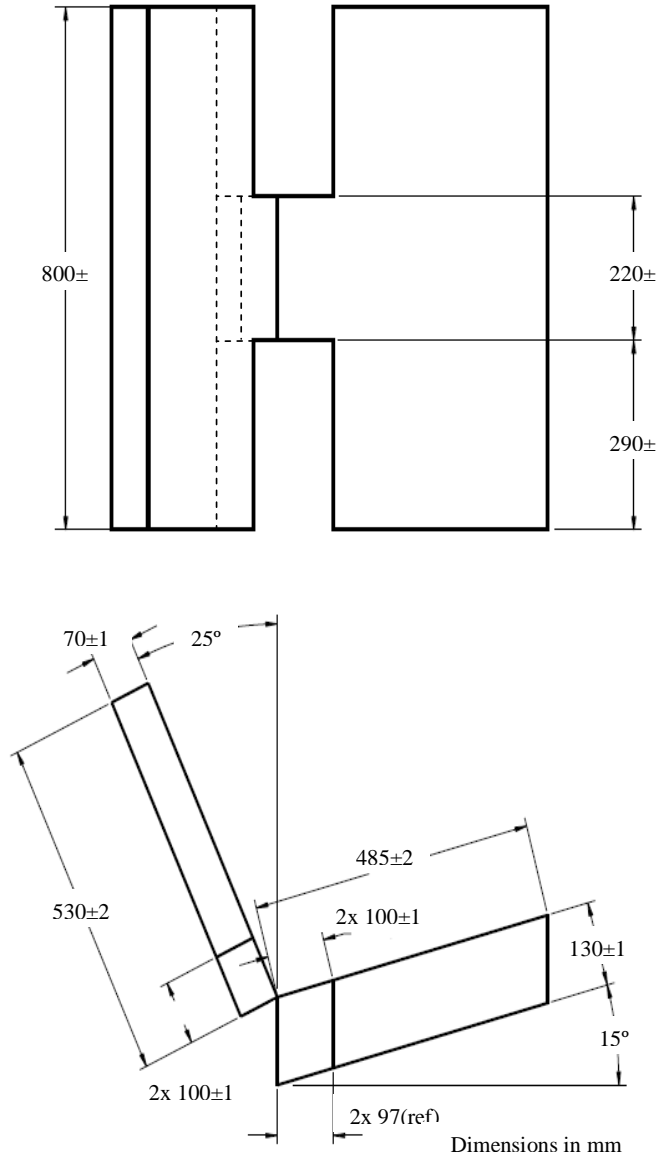

Figure 2
Dimensions of the aluminium bottom-plate

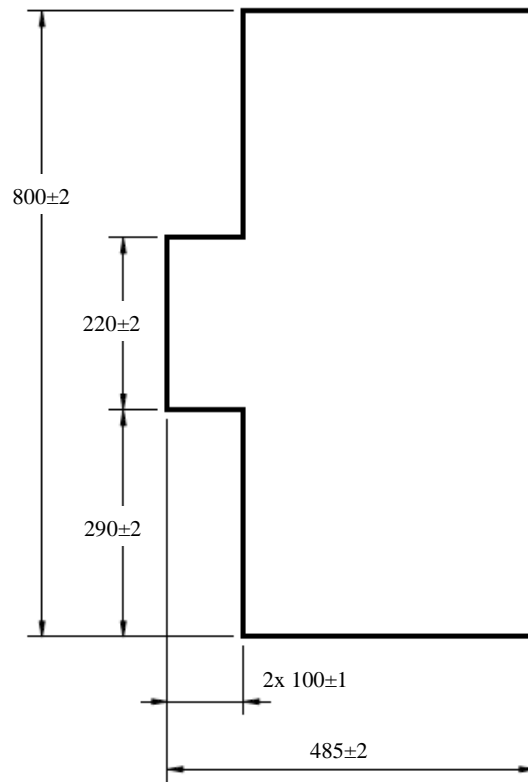

Figure 3
Dimensions of the cover material

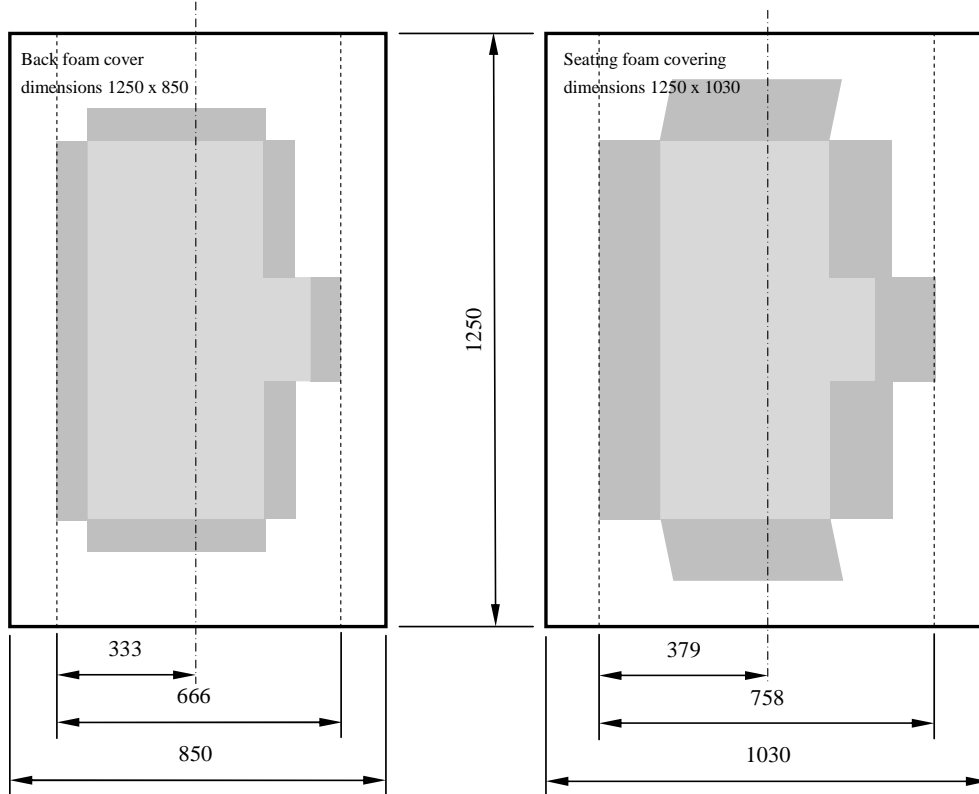
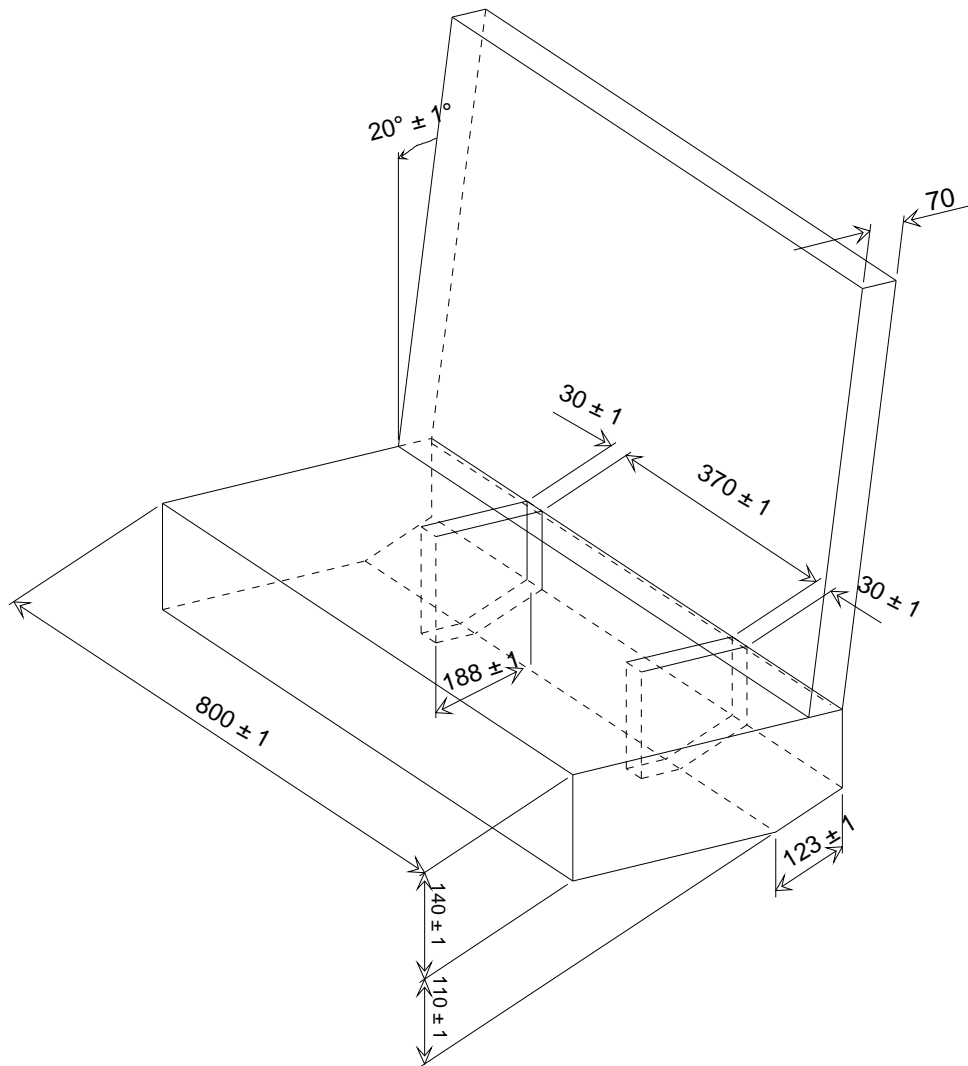

Figure 4
3-Dimensional view of test bench seat



Annex 6

Appendix 2

Arrangement and Use of Anchorages on the Test Trolley

1. The anchorages shall be positioned as shown in the figure below.
When attaching the standard anchorage plate to the anchorage points A and B or B0 the plates shall be mounted with the bolt in the transverse horizontal direction with the angled surface facing inboard and shall be free to rotate about the axis.
2. Child restraints in the “universal” and “restricted” categories shall use the following anchorage points:
 - 2.1. for child restraint using lap belts, points A and B;
 - 2.2. for child restraint using lap and diagonal belts, points A, B0 and C;
 - 2.3. for child restraints using ISOFIX attachment, rearmost point H1 and H2.
3. Anchorages A, B and/or (rearmost) H₁ H₂ and D shall be used for child restraints in the “semi-universal” category having only one additional upper anchorage.
4. Anchorages A, B and/or (rearmost) H₁ H₂, E and F shall be used for child restraints in the “semi-universal” category having only one additional upper anchorages.
5. Except in the case of point C (which represents the pillar loop position) the points, which correspond to the arrangement of the anchorages show where the ends of the belt are to be connected to the trolley or to the load transducer, as the case may be. The structure carrying the anchorages shall be rigid. The upper anchorages must not be displaced by more than 0.2 mm in the longitudinal direction when a load of 980 N is applied to them in that direction. The trolley shall be so constructed that no permanent deformation shall occur in the parts bearing the anchorages during the test.
6. For carry-cots, the points A₁ and/or B₁ can be used alternatively, as specified by the manufacturer of the restraint systems. A₁ and B₁ are located on a transverse line through R₁ at a distance of 350 mm from R₁.
7. For testing of child restraints with top tether, the anchorage G₁ or G₂ shall be used.
8. In the case of child restraints utilising a support-leg, the Technical Service shall select the anchorages to be used according to paragraphs 2., 3., 4. or 5. above and with the support-leg adjusted as specified in paragraph 7.1.3.6.3.

Annex 6

Appendix 3

Lateral impact and door panel description

1. Door panel Definition

The door panel geometry must be in line with the bench definition

Drawing to describe the door will be proposed in line with the NPACS Bench

Deletion of picture

2. Panel padding specification

2.1. General

The door panel is padded with 55 mm padding material, which has to comply with the performance criteria as described in paragraph 2.3. of this appendix realised in a test set up as described in paragraph 2.2. of this appendix. Finally an example for material meeting the requirements is described in paragraph 2.4. of this appendix.

2.2. Test procedure for the assessment of panel padding material

The test set up consists of a simple drop test using a spherical head form. The spherical head form has a diameter of 150 mm and a mass of 6 kg ($\pm 0,1$ kg). The impact speed is 4 m/s ($\pm 0,1$ m/s). The instrumentation should allow the assessment of the time of first contact between the impactor and the sample as well as the head form acceleration at least in direction of impact (Z-direction).

The material sample should have the dimensions of 400 X 400 mm. The sample should be impacted in its centre.

2.3. Performance criteria for the padding material

The time of first contact between sample material and head form (t_0) is 0 ms. The impactor acceleration shall not exceed 58 g.

Figure B.1

Corridor for the padding material

Deletion of Figure B.1

Key

1 Upper limit of 58 g

2 Lower limit for the maximum peak at 53 g (11 to 12 ms)

3 Upper limit for the decline of acceleration (15 g at 20,5 ms to 10 g at 21,5 ms)

4 Lower limit for the decline of acceleration (10 g at 20 ms to 7 g at 21 ms)

2.4. Example of material meeting the test requirements.

Using 35 mm rubber cell foam Polychloropren CR4271 at the side of the panel structure and 20 mm Styrodur C2500 on top guarantees to meet the requirements. The Styrodur needs to be replaced after each test.

Annex 7

Curve of trolley's deceleration or acceleration, as function of time

In all cases the calibration and measuring procedures shall correspond to those defined in the International Standard ISO 6487:~~2002~~; the measuring equipment shall correspond to the specification of a data channel with a channel frequency class (CFC) 60.

Annex 7

Appendix 1

[Curve of trolley's deceleration or acceleration, as function of time

Frontal Impact

<i>Definition of the different curves</i>		
Time (ms)	Acceleration (g)	
	Low corridor	High corridor
0	-	100
20	0	-
50	20	28
65	20	-
80	-	28
100	0	-
120	-	0

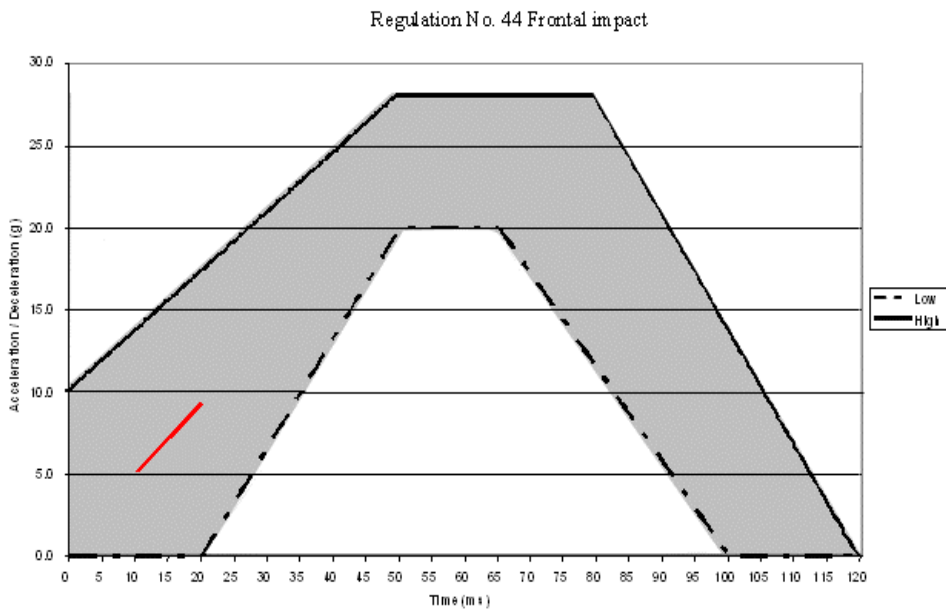

The additional segment (see paragraph 7.1.3.1.1.3.2.) applies only for the acceleration sled.] **Corridors to be revised.**

Annex 7

Appendix 2

[Curves of trolley's deceleration or acceleration, as function of time

Rear impact

<i>Definition of the different curves</i>		
Time (ms)	Acceleration (g)	
	Low corridor	High corridor
0	-	21
10	0	
10	7	-
20	14	-
37	14	-
52	7	-
52	0	
70	-	21
70	-	0

Regulation No. 44 Rear impact

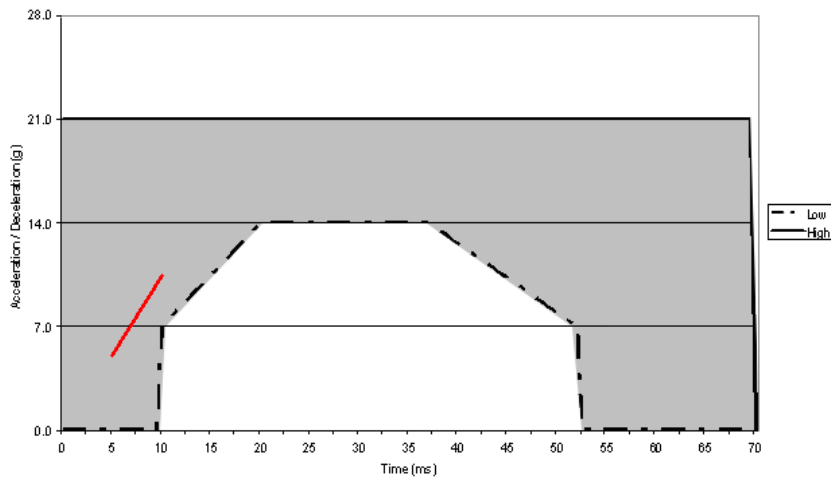

The additional segment (see paragraph 7.1.3.1.1.3.2.) applies only for the acceleration sled.]
Corridors to be revised.

Annex 7

[Appendix 3 -

Curve of relative velocity between trolley and door panel as function of time

Side Lateral Impact

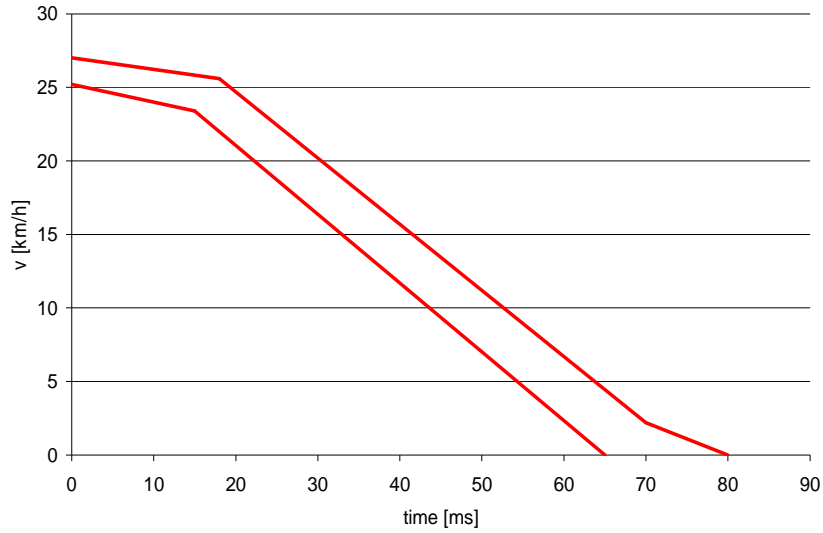

Definition of the different curves

Time (ms)	Door Bench Relative Velocity (m/s) Low corridor	Door Bench Relative Velocity (m/s) High corridor
0	7	7.5
15	6.5	-
18	-	7.1
18	-	-
65	0	-
70	-	0.6
80	-	0

Remark: The corridor must be defined on experiences of respective test labs.

Corridors to be revised.

Definition of Door maximum intrusion

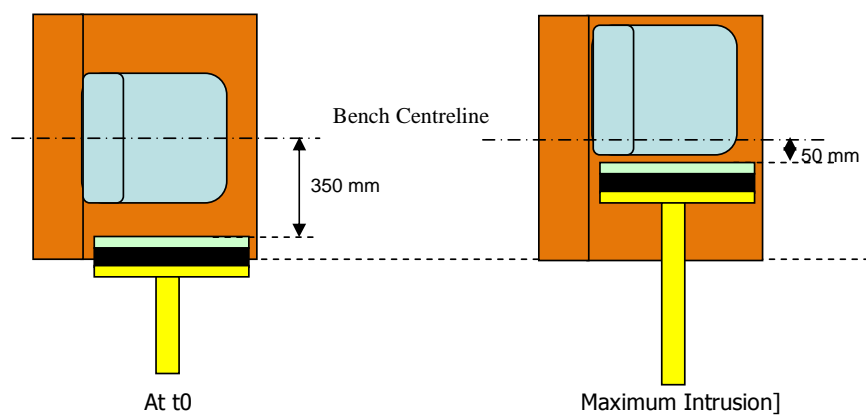

Annex 7

[Appendix 4

1. Door panel Definition

The door panel geometry must be in line with the bench definition.

Drawing to describe the door will be proposed in line with the NPACS Bench.
2. Panel padding specification
 - 2.1. General

The door panel is padded with 55 mm padding material, which has to comply with the performance criteria as described in Annex 6 Appendix 3 paragraph 2.3. realised in a test set up as described in Annex 6 Appendix 3 paragraph 2.2. Finally an example for material meeting the requirements is described in Annex 6 Appendix 3 paragraph 2.4.
 - 2.2. Test procedure for the assessment of panel padding material

The test set up consists of a simple drop test using a spherical head form. The spherical head form has a diameter of 150 mm and a mass of 6 kg (± 0.1 kg). The impact speed is 4 m/s (± 0.1 m/s). The instrumentation should allow the assessment of the time of first contact between the impactor and the sample as well as the head form acceleration at least in direction of impact (Z-direction).

The material sample should have the dimensions of 400 X 400 mm. The sample should be impacted in its centre.
 - 2.3. Performance criteria for the padding material

The time of first contact between sample material and head form (t_0) is 0 ms.

The impactor acceleration shall not exceed 58 g.

Figure for door definition is needed.

Figure B.1

Corridor for the padding material

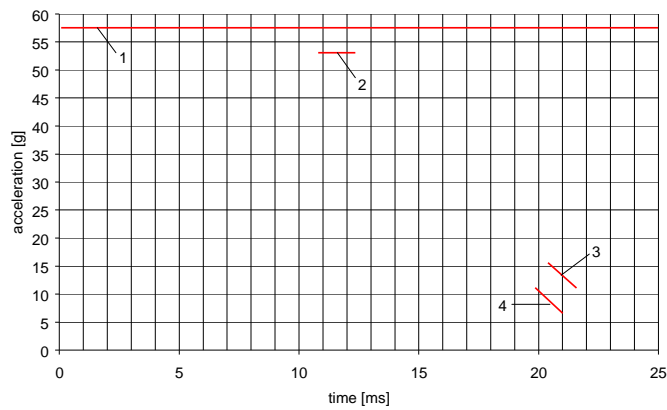

Key

- 1- Upper limit of 58 g
- 2- Lower limit for the maximum peak at 53 g (11 to 12 ms)
- 3- Upper limit for the decline of acceleration (15 g at 20,5 ms to 10 g at 21,5 ms)
- 4- Lower limit for the decline of acceleration (10 g at 20 ms to 7 g at 21 ms)

2.4. Example of material meeting the test requirements:

Using 35 mm rubber cell foam Polychloropren CR4271 at the side of the panel structure and 20 mm Styrodur C2500 on top guarantees to meet the requirements. The Styrodur needs to be replaced after each test.

Remark: [Styrodur C2000 is not available, but 2500 could be an acceptable alternative as it is available and used for current testing.]

[Overall test rig lay out]] **Corridors to be revised.**

Annex 8

Description of Manikins

1. General
 - 1.1. The manikins prescribed in this Regulation are described in this Annex, in technical drawing held by First Technology Safety Systems and in the user manuals delivered with the dummies.
 - 1.2. Alternative manikins may be used provided that:
 - 1.2.1. their equivalence can be demonstrated to the satisfaction of the competent authority, and
 - 1.2.2. their use is recorded in the test report, and in the communication form described in Annex 1 to this Regulation.
2. Description of the Manikins
 - 2.1. The dimensions and masses of the manikins called Q0, Q1, Q1.5, Q3 and Q6 [and Q10] described below are based on the anthropometry of 50th per centile children aged 0, 1, 1.5, 3 and 6 [and 10.5] years respectively.
 - 2.2. The manikins consist of a metal and plastic skeleton covered with plastic skinned foam parts to complete body components.
 - 2.3. For overview of the manikins, see below.

[To be defined]

Q-dummy family from left to right: Q1.5, Q3, Q0, Q6 and Q1 [Q10 ~~dummy~~ **manikin**, being under development, not yet shown]

3. Construction
 - 3.1. Head

The head is largely made from synthetics. The head cavity is large enough to allow use of several instruments, including linear accelerometers and angular velocity sensors.
 - 3.2. Neck

The neck is flexible and allows shear and bending in all directions. The segmented design allows a realistic rotational behaviour. The neck is equipped with low stretch neck-cord in order to prevent excessive elongation. The neck-cord is also designed to act as a safety cord in case of rubber failure. A six channel load cell can be mounted at the neck-head and neck-torso interface. The Q0, Q1 and Q1.5 cannot accommodate the load cell between neck and torso.
 - 3.3. Thorax

The thorax of the child is represented by a single rib-cage. The deformation can be measured with a string potentiometer in Q1 and Q1.5 and an IR-TRACC sensors in Q3 and Q6 [and Q10]. The shoulders are connected with a flexible joint to the thorax, allowing deformation forwards.
 - 3.4. Accelerometers can be mounted on the spine to measure linear accelerations. The Q0 thorax has a simplified layout with an integral foam part for the complete torso.
 - 3.5. Abdomen

The abdomen is foam covered with skin. Biomechanical data from children has been used to determine the required stiffness. The Q0 abdomen has a simplified layout with an integral foam part for the complete torso.
 - 3.6. Lumbar spine

The lumbar spine is a flexible rubber column, which allows shear and bending in all directions. A six channel load cell can be mounted between the lumbar spine and the pelvis, except for the Q0.
 - 3.7. Pelvis

The pelvis is constructed from a iliac-sacrum bone part covered with a plastic flesh outer contour simulation. In the bone part removable hip joints are inserted. An accelerometer array can be mounted in the pelvis. Special hip joints are available that allow to position the ~~dummy~~ **manikin** in a standing position. The Q0 pelvis has a simplified layout with an integral foam part for the complete torso.
 - 3.8. Legs

The legs are constructed with metal reinforced plastic bones cover with PVC skinned foam parts that represent the upper and lower flesh. The knee joints can be locked in any position. This feature can be used to facilitate positioning the ~~dummy~~ **manikin** in a standing position. (Note that the ~~dummy~~ **manikin** does not have the ability to stand without external support.) The Q0 legs have a simplified layout with one integral part per leg with a fixed angle at the knee.
 - 3.9. Arms

The arms are constructed with plastic bones cover with PVC skinned foam parts that represent the upper and lower flesh. The elbow joints can be locked in any position. The Q0 arms have a simplified layout with one integral part per leg with a fixed angle at the knee.

4. Main characteristics

4.1. Mass

Table 1
Q-dummy manikin mass distributions

	<i>Q0</i>	<i>Q1</i>	<i>Q1.5</i>	<i>Q3</i>	<i>Q6</i>	<i>Q10 Design targets</i>
	Mass in [kg]					
Head + Neck (incl. acc. mount)	1.10±0.10	2.41±0.10	2.80±0.10	3.17±0.10	3.94±0.10	[4.19]
Torso (incl. acc. mount and chest deflection sensor)	1.50±0.15	4.21±0.25	4.74±0.25	6.00±0.30	9.07±0.40	[14.85] (incl. suit)
Legs (together)	0.58±0.06	1.82±0.10	3.06±0.10	3.54±0.10	6.90±0.10	[12.50]
Arms (together)	0.28±0.03	0.89±0.10	1.20±0.10	1.48±0.10	2.49±0.10	[4.00]
Suit	0.27±0.05	0.27±0.05	0.30±0.05	0.40±0.10	0.55±0.10	(see torso)
Total	3.46±0.34	9.6±0.30	11.10±0.40	14.60±0.40	22.90±0.40	[35.50]

4.2. Principal dimensions

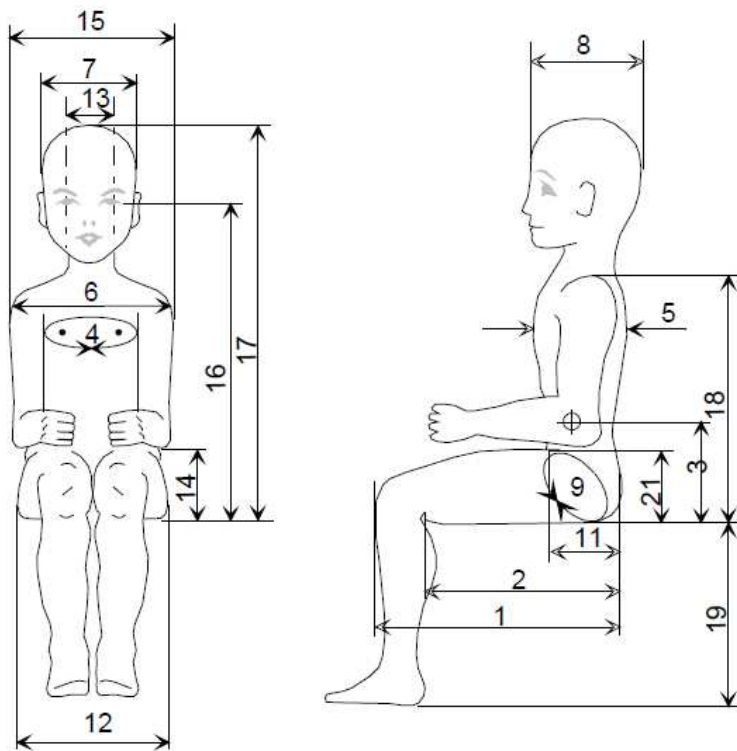

Figure 2 Main dimensions of manikin

Table 2- Q-dummy manikin dimensions

No.		Q0	Q1	Q1.5	Q3	Q6	[Q10]
							(design targets)
Dimensions in [mm]							
17	Seating height (head tilted forward)	355±9	479±9	499±9	544±9	601±9	< 748±9
18	Shoulder height (sitting)	225±7	298±7	309±7	329±7	362±7	473±7
	Stature (head tilted forward)	-	740±9	800±9	985±9	1143±9	< 1443±9
5	Chest depth	-	114±5	113±5	146±5	141±5	171±5
15	Shoulder width	230±7	227±7	227±7	259±7	305±7	338±7
12	Hip width	-	191±7	194±7	200±7	223±7	270±7
1	Back of buttocks to front of knees	130±5	211±5	235±5	305±5	366±5	488±5
2	Back of buttocks to popliteus	-	161±5	185±5	253±5	299±5	418±5
21	Thigh height, sitting		69	72	79	92	114
	Height of spacer device for positioning of manikin ¹⁾		229±2	237±2	250±2	270±2	359±2

1) See section 7.1.3.5.2.2: Height of spacer device (hinged board or similar flexible device) equals shoulder height sitting minus thigh height sitting.

Request FTSS: Please add relevant dimensions to be included (e.g. is neck width (13) relevant?)

1. Adjustments of joints

Joints should be adjusted according to procedures included in the Q-manikin manuals [as deposited to the secretariat of UNECE]

2. Instrumentation

Instrumentation in the Q-Dummy manikin's should be installed and calibration according to procedures included in the Q-manikin manuals [as deposited to the secretariat of UNECE]

Annex 9

Frontal Impact Test against a Barrier

- 1.1. Testing ground

The test area shall be large enough to accommodate the run-up track, barrier and technical installations necessary for the test. The last part of the track, for at least 5 m before the barrier, must be horizontal, flat and smooth.
- 1.2. Barrier

The barrier consists of a block of reinforced concrete not less than 3 m wide at the front and not less than 1.5 m high. The barrier must be of such thickness that it weighs at least 70 tonnes. The front face must be vertical, perpendicular to the axis of the run-up track, and covered with plywood boards 20 ± 1 mm thick in good condition. The barrier shall be either anchored in the ground or placed on the ground with, if necessary, additional arresting devices to limit its displacement. A barrier with different characteristics, but giving results at least equally conclusive, may likewise be used.
- 1.3. Propulsion of the vehicle

At the moment of impact, the vehicle must no longer be subjected to the action of any additional steering or propelling device or devices. It must reach the obstacle on a course perpendicular to the collision wall; the maximum lateral disalignment permitted between the vertical median line of the front of the vehicle and the vertical median line of the collision wall is ± 30 cm.
- 1.4. State of the vehicle
 - 1.4.1. The vehicle under test must either be fitted with all the normal components and equipment included in its unladen service weight or be in such a condition as to fulfil this requirement in so far as the components and equipment of concern to the passenger compartment and the distribution of the service weight of the vehicle as a whole are concerned.
 - 1.4.2. If the vehicle is driven by external means, the fuel installation must be filled to at least 90 per cent of its capacity, either with fuel or with a non-inflammable liquid, having a density and a viscosity close to those of the fuel normally used. All other systems (brake-fluid containers, radiator, etc.) must be empty.
 - 1.4.3. If the vehicle is driven by its own engine, the fuel tank must be at least 90 per cent full. All other liquid-holding tanks must be filled to capacity.
 - 1.4.4. If the manufacturer so requests, the Technical Service responsible for conducting the tests may allow the same vehicle as is used for tests prescribed by other Regulations (including tests capable of affecting its structure) to be used also for the tests prescribed by this Regulation.
- 1.5. Impact velocity

The impact velocity must be 50 \pm 2 km/h. However, if the test has been carried out at a higher impact velocity and the vehicle has satisfied the conditions prescribed, the test is considered satisfactory.

1.6. Measuring instruments

The instrument used to record the speed referred to in paragraph 1.5. above shall be accurate within 1 per cent.

Annex 10

Rear impact test procedure

1. Installations, procedures and measuring instruments
 - 1.1. Testing ground

The test area shall be large enough to accommodate the propulsion system of the impactor and to permit after-impact displacement of the vehicle impacted and installation of the test equipment. The part in which vehicle impact and displacement occur shall be horizontal. (The slope shall be less than 3 per cent measured over any length of one metre.)
 - 1.2. Impactor
 - 1.2.1. The impactor shall be of steel and of rigid construction.
 - 1.2.2. The impacting surface shall be flat and at least 2,500 mm wide and 800 mm high. Its edges shall be rounded to a radius of curvature of between 40 and 50 mm. It shall be clad with a layer of plywood 20 ± 1 mm thick.
 - 1.2.3. At the moment of impact the following requirements shall be met:
 - 1.2.3.1. the impacting surface shall be vertical and perpendicular to the median longitudinal plane of the impacted vehicle;
 - 1.2.3.2. the direction of movement of the impactor shall be substantially horizontal and parallel to the median longitudinal plane of the impacted vehicle;
 - 1.2.3.3. the maximum lateral deviation permitted between the median vertical line of the surface of the impactor and the median longitudinal plane of the impacted vehicle shall be 300 mm. In addition, the impacting surface shall extend over the entire width of the impacted vehicle;
 - 1.2.3.4. the ground clearance of the lower edge of the impacting surface shall be 175 ± 25 mm.
 - 1.3. Propulsion of the impactor

The impactor may either be secured to a carriage (moving barrier) or form part of a pendulum.
 - 1.4. Special provisions applicable where a moving barrier is used
 - 1.4.1. If the impactor is secured to a carriage (moving barrier) by a restraining element, the latter must be rigid and be incapable of being deformed by the impact; the carriage shall, at the moment of impact, be capable of moving freely and no longer be subject to the action of the propelling device.
 - 1.4.2. The combined mass of carriage and impactor shall be $1,100 \pm 20$ kg.
 - 1.5. Special provisions applicable where a pendulum is used
 - 1.5.1. The distance between the centre of the impacting surface and the axis of rotation of the pendulum shall be not less than 5 m.
 - 1.5.2. The impactor shall be freely suspended by rigid arms, rigidly secured to it. The pendulum so constituted shall be substantially incapable of being deformed by the impact.

- 1.5.3. A stopping device shall be incorporated in the pendulum to prevent any secondary impact by the impactor on the test vehicle.
- 1.5.4. At the moment of impact, the velocity of the centre of percussion of the pendulum shall be between 30 and 32 km/h.
- 1.5.5. The reduced mass “ m_r ” at the centre of percussion of the pendulum is defined as a function of the total mass “ m ”, of the distance “ a ”¹ between the centre of percussion and the axis of rotation, and of the distance “ l ” between the centre of gravity and the axis of rotation, by the following equation:

$$m_r = m \cdot \frac{l}{a}$$

- 1.5.6. The reduced mass “ m_r ” shall be $1,100 \pm 20$ kg.
- 1.6. General provisions relating to the mass and velocity of the impactor
If the test has been conducted at an impact velocity higher than those prescribed in paragraph 1.5.4. and/or with a mass greater than those prescribed in paragraphs 1.5.3. or 1.5.6., and the vehicle has met the requirements prescribed, the test shall be considered satisfactory.
- 1.7. State of the vehicle during the test
The vehicle being tested shall either be fitted with all the normal components and equipment included in its unladen service weight or be in such condition as to fulfil this requirement in so far as the distribution of the service weight of the vehicle as a whole is concerned.
- 1.8. The complete vehicle with the child restraint installed in accordance with the fitting instructions shall be placed on a hard, flat and level surface, with the handbrake off and in neutral gear. More than one child restraint may be tested in the same impact test.

¹ The distance “ a ” is equal to the length of the synchronous pendulum under consideration.

Deleted: Annex 11¶
 . Lateral impact test procedure¶
 [Text to be defined]
 wwwSection Break (Next Page)www

Annex 12

Type approval scheme (Flow Chart ISO 9002:2000)

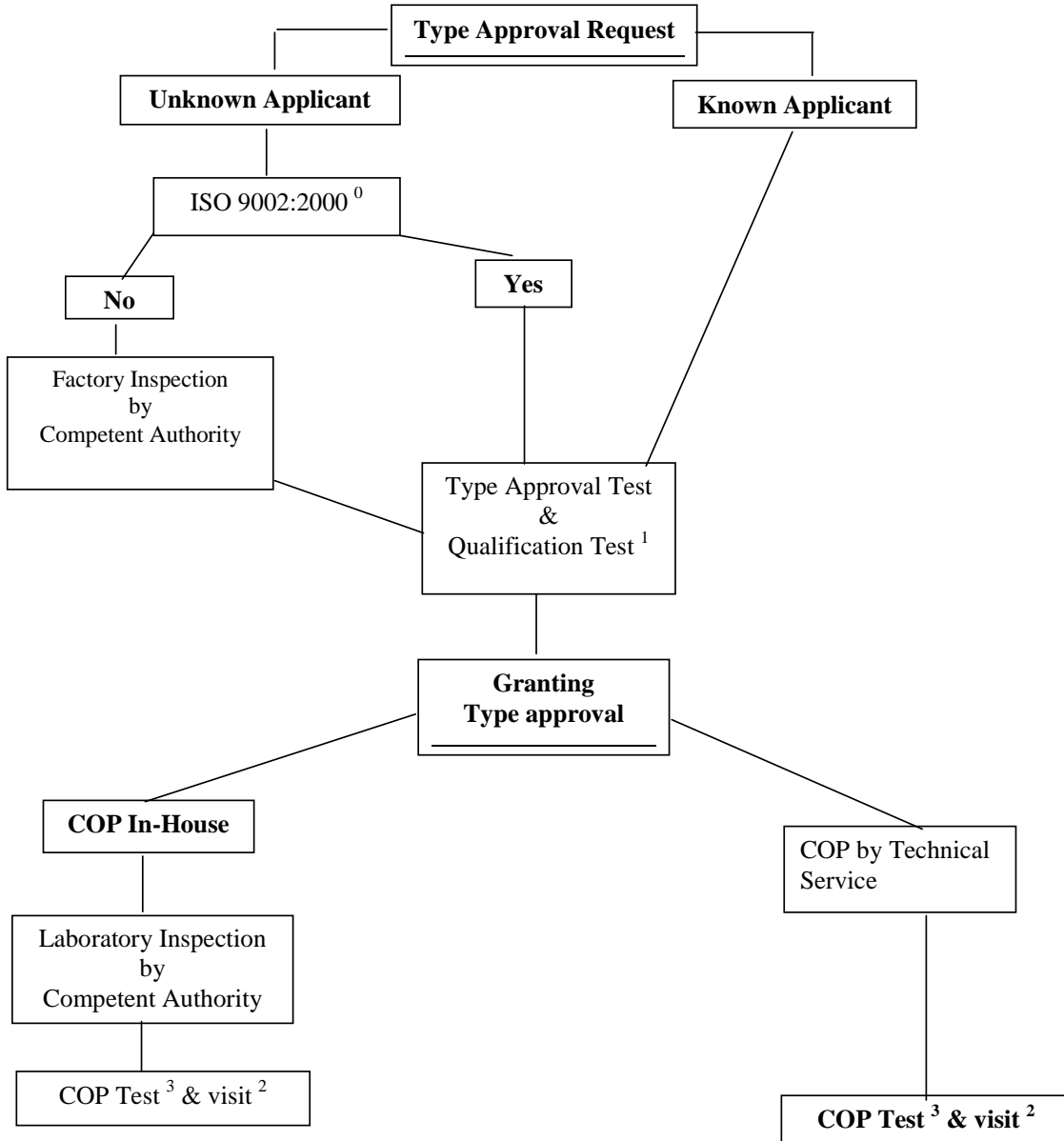

Notes:

0. or an equivalent standard to this one with the permissible exclusion of the requirements related to the concepts of design and development; point 7.3. "Customer satisfaction and continual improvement"

1. these tests shall be done by Technical Service
2. visit to the manufacturer for inspection and random sampling by the Authority or Technical Service
 - (a) if there is no ISO 9002:2000: 2 times a year
 - (b) if there is an ISO 9002:2000: 1 time a year
3. tests in accordance with Annex 13
 - (a) if there is no ISO 9002:2000:
 - (i) of the Authority or Technical Service during the visit of footnote 2a
 - (ii) of the manufacturer between the visits of footnote 2b
 - (b) if there is an ISO 9002:2000: taken by the manufacturer, procedure checked during visit of footnote 2b.

Annex 13

Control of conformity of production

1. Tests

Child Restraint Systems shall be required to demonstrate compliance with the requirements on which the following tests are based:
- 1.1. Verification of the locking threshold and durability of emergency locking retractors

According to the provisions of paragraph 7.2.4.3. in the most unfavourable direction as appropriate after having undergone the durability testing detailed in paragraphs 7.2.4.2., 7.2.4.4. and 7.2.4.5. as a requirement of paragraph 6.7.3.2.6.
- 1.2. Verification of the durability of automatically locking retractors

According to the provisions of paragraph 7.2.4.2. supplemented by the tests in paragraphs 7.2.4.4. and 7.2.4.5. as a requirement of paragraph 6.7.3.1.3.
- 1.3. Test for strength of straps after conditioning

According to the procedure described in paragraph 6.7.4.2. after conditioning according to the requirements of paragraphs 7.2.5.2.1. to 7.2.5.2.5.
- 1.3.1. Test for strength of straps after abrasion

According to the procedure described in paragraph 6.7.4.2. after conditioning according to the requirements described in paragraph 7.2.5.2.6.
- 1.4. Microslip test

According to the procedure described in paragraph 7.2.3. of this Regulation.
- 1.5. Energy absorption

According to the provisions of paragraph 6.6.2. of this Regulation.
- 1.6. Verification of the performance requirements of the Child Restraint System when subjected to the appropriate dynamic test:

According to the provisions set out in paragraph 7.1.3. with any buckle having been pre-conditioned according to the requirements of paragraph 6.7.16. such that the appropriate requirements of paragraph 6.6.4. (for the overall performance of the child restraint) and paragraph 6.7.1.7.1. (for the performance of any buckle under load) are complied with.
- 1.7. Temperature test

According to the provisions of paragraph 6.6.5. of this Regulation.
2. Test frequency and results
 - 2.1. The frequency of testing to the requirements of paragraphs 1.1. to 1.5. and 1.7. shall be on a statistically controlled and random basis in accordance with one of the regular quality assurance procedure, and must be conducted at least once per year.

2.2. Minimum conditions for the control of conformity of Child Restraint Systems of categories “Universal”, “Semi Universal” and “Restricted”, in relation to the dynamic tests according to paragraph 1.6.

In accordance with the relevant authorities, the holder of an approval will supervise the control of conformity following the method of batch control (paragraph 2.2.1.) or following the method of continuous control (paragraph 2.2.2.).

2.2.1. Batch control for the Child Restraint Systems

2.2.1.1. The holder of an approval must divide the Child Restraint Systems into batches which are as uniform as possible in regard to raw material or intermediate products involved in their manufacture (different colour of shell, different manufacture of harness) and in regard to production conditions. The numbers in a batch must not exceed 5000 units.

In agreement with the relevant authorities the tests can be carried out by the Technical Service authorities or under the responsibility of the holder of an approval.

2.2.1.2. A sample must be taken in each batch in accordance with the provisions of paragraph 2.2.1.4. from a minimum of 20 per cent of the batch quantity, which has to be produced of the actual batch.

2.2.1.3. The characteristics of the Child Restraint Systems and the number of dynamic tests to be conducted are given in paragraph 2.2.1.4.

2.2.1.4. In order to be accepted, a batch of Child Restraint Systems must satisfy the following conditions.

<i>Number in the batch</i>	<i>Number of samples/Child Restraint Systems characteristics</i>	<i>Combined number of samples</i>	<i>Acceptance criteria</i>	<i>Rejection criteria</i>	<i>Degree of control rigour</i>
N<500	1st = 1MH	1	0	-	Normal
	2nd = 1MH	2	1	2	
500<N<5000	1st = 1MH+1LH	2	0	2	Normal
	2nd = 1MH+1LH	4	1	2	
N<500	1st = 2MH	2	0	2	Strengthened
	2nd = 2MH	4	1	2	
500<N<5000	1st = 2MH+2LH	4	0	2	Strengthened
	2nd = 2MH+2LH	8	1	2	

Note:

MH signifies harder configuration (the least good results obtained in approval or extension of approval)

LH signifies a less hard configuration.

This dual sampling plan functions as follows:

For a normal control, if the first sample does not contain any defective units the batch is accepted without testing a second sample. If it contains two defective units the batch is rejected. Finally, if it contains one defective unit a second sample is extracted and it is the cumulative number, which must satisfy the condition of column 5 of the table above.

There is a change from normal control to strengthened control if, out of 5 consecutive batches, two are rejected. Normal control is resumed if 5 consecutive batches are accepted.
 If any batch is rejected, the production is considered to be non-conforming and the batch shall not be released.
 If two consecutive batches subjected to the strengthened control are rejected, the provisions of paragraph 13. are applied.

- 2.2.1.5. The control of Child Restraint Systems conformity is undertaken starting with the batch manufactured after the first batch which was subjected to production qualification.
- 2.2.1.6. The test results described in paragraph 2.2.1.4. shall not exceed L, where L is the limit value prescribed for each approval test.
- 2.2.2. Continuous control
 - 2.2.2.1. The holder of an approval shall be obliged to carry out continuous quality control of his manufacturing process on a statistical basis and by sampling. In agreement with the relevant authorities, the tests can be carried out by the Technical Service authorities or under the responsibility of the holder of an approval which is responsible for the traceability of the product.
 - 2.2.2.2. The samples must be taken in accordance with the provisions of paragraph 2.2.2.4.
 - 2.2.2.3. The characteristic of the Child Restraint Systems is taken at random and the tests to be carried out are described in paragraph 2.2.2.4.
 - 2.2.2.4. Control shall meet the following requirements:

<i>Child Restraint Systems taken</i>	<i>Degree of control rigour</i>
0.02 per cent means one Child Restraint System taken from every 5000 manufactured	Normal
0.05 per cent means one Child Restraint System taken from every 2000 manufactured	Strengthened

This dual sampling plan functions as follows:

If the Child Restraint System is considered to conform, the production conforms.

If the Child Restraint System does not meet the requirements, a second Child Restraint System shall be taken.

If the second Child Restraint System meets the requirements, the production conforms.

If both (the first and the second) Child Restraint Systems do not meet the requirements, the production does not conform and Child Restraint Systems that are likely to present the same failure shall be withdrawn and necessary steps shall be taken to re-establish the conformity of the production.

Strengthened control will replace normal control if, out of 10,000 Child Restraint Systems manufactured consecutively, the production has to be withdrawn twice.

Normal control is resumed if 10,000 Child Restraint Systems manufactured consecutively are considered to conform.

- If production subjected to the strengthened control has been withdrawn on two consecutive occasions, the provisions of paragraph 13. are applied.
- 2.2.2.5. The continuous control of Child Restraint Systems is undertaken starting after the production qualification.
- 2.2.2.6. The test results described in paragraph 2.2.2.4. shall not exceed L, where L is the limit value prescribed for each approval test.
- 2.3. For Q -Size “vehicle-specific” devices according to paragraph 2.1.2.4.1., the child restraint manufacturer may choose Conformity of Production procedures according to either paragraph 2.2., on a test ~~seat~~**bench**, or paragraphs 2.3.1. and 2.3.2., in a vehicle body shell.
- 2.3.1. For Q -Size “vehicle specific” devices, the following test frequencies shall apply once every 8 weeks:
- At each test all requirements according to paragraphs 6.6.4. and 6.7.1.7.1. must be fulfilled. If all tests during one year show satisfactory results, the manufacturer may, after agreement with the competent authority, reduce the frequencies as follows: once every 16 weeks.
- However, a minimum frequency of one test per year shall be permitted where annual production is 1,000 Child Restraint Systems or less.
- 2.3.2. Where a test sample fails a particular test to which it has been subjected, a further test to the same requirement shall be carried out on at least three other samples. In the case of dynamic tests if one of the latter fails, the production is considered to be non-conforming and the frequency shall be raised to the higher one if the lower one was used according to paragraph 2.3. and necessary steps shall be taken to re-establish the conformity of the production.
- 2.4. When production is found to be non-conforming according to paragraphs 2.2.1.4., 2.2.2.4. or 2.3.2. , the holder of the approval or his duly accredited representative shall:
- 2.4.1. Notify the Competent Authority which has granted type approval indicating what steps have been taken to re-establish the conformity of production.
- 2.5. The manufacturer must advise the competent authority on a quarterly basis, the volume of products produced against each approval number, providing a means of identifying which products correspond to that approval number.

Annex 14

Test of energy absorbing material

1. Headform
 - 1.1. The headform shall consist of a solid wooden hemisphere with an added smaller spherical segment as shown in figure A below. It shall be constructed so that it can be dropped freely along the axis marked and it shall have provision for mounting an accelerometer in order to measure the acceleration along the direction of fall.
 - 1.2. The headform shall have a total mass, including the accelerometer of 2.75 ± 0.05 kg.

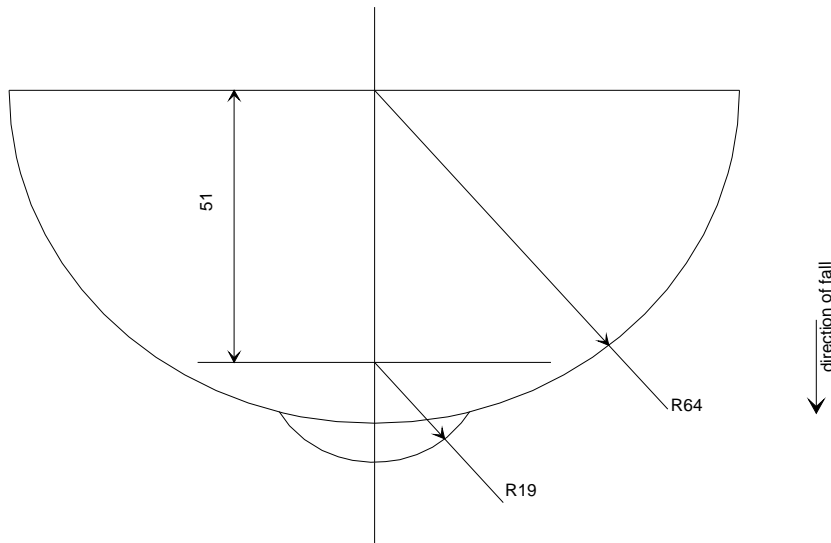

Figure A
Headform

2. Instrumentation

The acceleration shall be recorded during the test, using equipment in accordance with channel frequency class 1000 as specified in the latest version of ISO 6487.
3. Procedure
 - 3.3. The test shall be conducted on a completely assembled child restraint with a minimum of modification only where necessary to ensure access for the support (directly beneath the point of impact) and for the impactor device and such that there is minimal effect on the performance by the modification.
 - 3.4. The assembled child restraint shall be fully supported on its outer surface in the region of impact and be supported directly beneath the point of impact on a smooth rigid base, for example a solid concrete plinth.

- 3.5. Raise the headform to a height of 100 $-0/+5$ mm from the respective upper surfaces of the assembled child restraint to the lowest point on the headform, and allow it to fall. Record the acceleration experienced by the headform during impact.

Annex 15

Method of defining head impact area of devices with backrests and for rearward-facing devices defining the minimum size of side wings

1. Place the device on the test ~~seat-bench~~ described in Annex 6. Reclinable devices shall be set in the most upright position. Place the smallest manikin in the device in accordance with the manufacturer's instructions. Mark a point "A" on the backrest on the same horizontal level as the shoulder of the smallest manikin at a point 2 cm inside the outer edge of the arm. All internal surfaces above the horizontal plane passing through point A shall comprise special energy-absorbing material tested in accordance with Annex 14. This material shall cover the internal surfaces of the backrest and side wings, including the inner edges (zone of radius) of the side wings. The energy absorbing material may be an integral part of the Child ~~Seat~~ **Restraint System**. In the case of carry cot devices where a symmetrical installation of the ~~dummy-manikin~~ is not possible according to the device and manufacturer instructions, the lower limit of area at which material complying with Annex 14 shall be used, shall be all areas beyond ~~dummy's-manikin's~~ shoulder in the head direction, when measured with this ~~dummy-manikin~~ in the carry cot in its worst position consistent with the manufactures instructions and the carry cot positioned on the test bench.

If a symmetrical installation of the ~~dummy-manikin~~ in the carry-cot may be possible, the whole inner surfaces shall be covered with material complying with Annex 14; this material has to fulfill its purpose together with the inner side structure; the Technical Service may assess this aspect with further tests.

2. For rearward-facing devices there shall be side wings with a depth of minimum 90 mm measured from the median of the surface of the backrest. These side wings shall start at the horizontal plane passing through point "A" and continue to the top of the **Child Restraint System** seat-back. Starting from a point 90 mm below the top of the **Child Restraint System** seat-back, the depth of the side wing may be gradually reduced.

Annex 16

Description of conditioning of adjusters mounted directly on child restraints

Figure 1

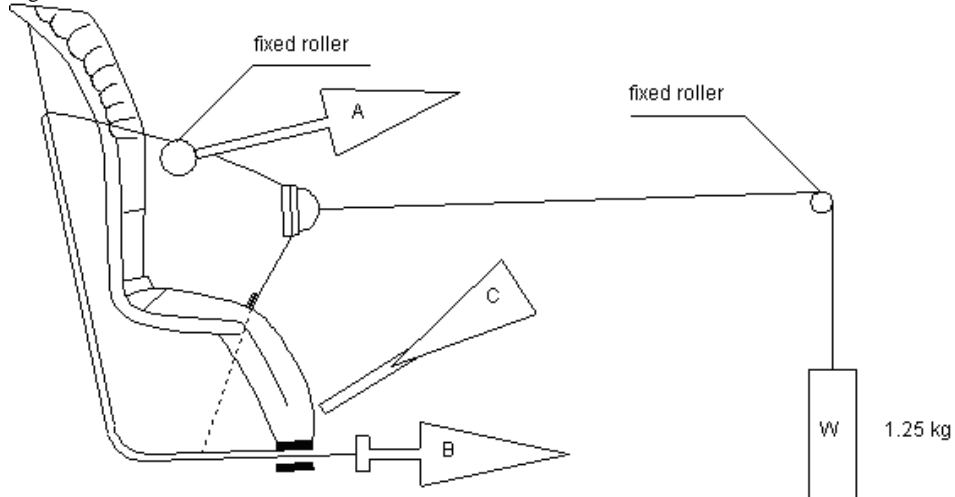

1. Method
 - 1.1. With the webbing set at the reference position described in paragraph 7.2.6., withdraw at least 50 mm of webbing from the integral harness by pulling on the free end of the webbing.
 - 1.2. Attach the adjusted part of the integral harness to the pulling device A.
 - 1.3. Activate the adjuster and pull at least 150 mm of webbing into the integral harness. This represents half of one cycle and puts pulling device A to the maximum webbing extraction position.
 - 1.4. Connect free end of webbing to pulling device B.
2. The cycle is:
 - 2.1. Pull B at least 150 mm whilst A exerts no tension on the integral harness.
 - 2.2. Activate the adjusters and pull A whilst B exerts no tension on the free end of the webbing.
 - 2.3. At the end of stroke, de-activate the adjuster.
 - 2.4. Repeat cycle as specified in paragraph 6.7.2.7.

Annex 17

Typical buckle strength test device

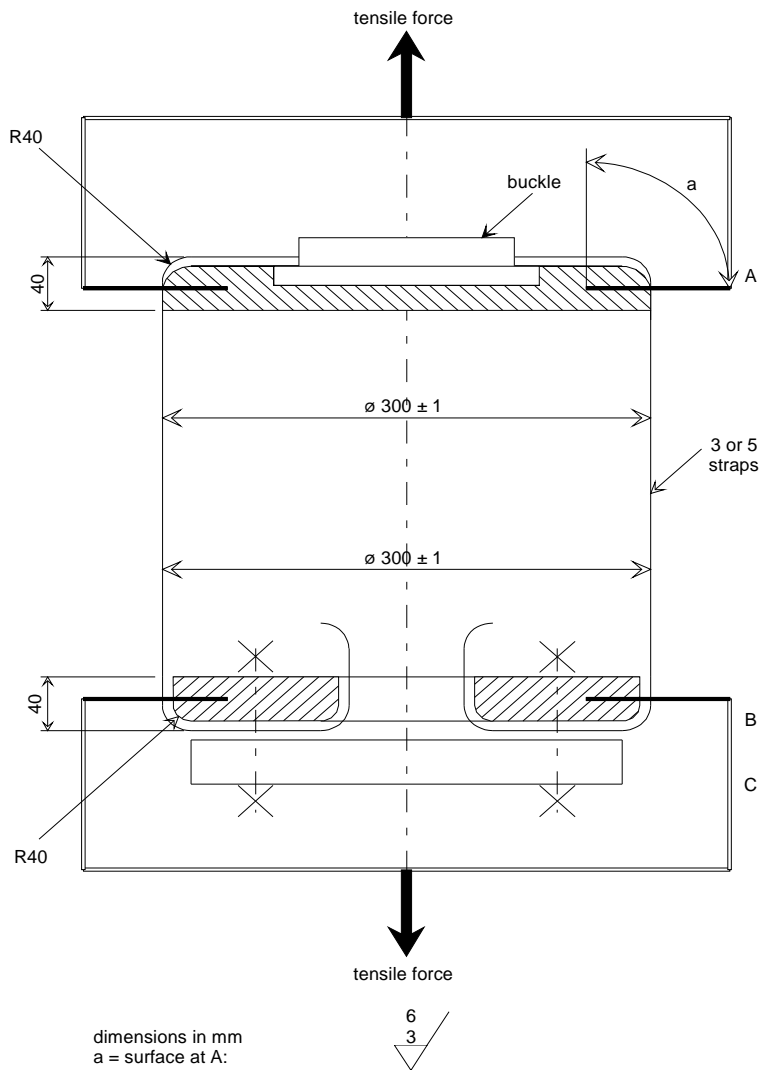

Annex 18

Dynamic crash test installation

[Figure to be defined]

1. Method
 - 1.1. ISOFIX attachment

For an ISOFIX Child Restraint System with adjustable position seat bight ISOFIX anchorages attach the unladen ISOFIX Child Restraint System onto the seat bight anchorages H1-H2 in the appropriate test position. Allow the ISOFIX child restraint latch mechanisms to pull the unladen ISOFIX Child Restraint System towards the seat bight. Apply an additional force of 135 ± 15 N in a plane parallel to the test bench seat cushion surface in the direction of the seat bight to overcome frictional forces between the ISOFIX Child Restraint System and the **test bench** seat cushion, assisting the self-tensioning effects of the latch mechanism. The force shall be applied on or equally about the centerline of the ISOFIX Child Restraint **System** and at a height not more than 100 mm above the test bench **seat** cushion surface. If needed, adjust the top tether to achieve a tension load of 50 ± 5 N.¹ Place appropriate test ~~dummy~~ **manikin** in child restraint when the ISOFIX Child Restraint System has been so adjusted.
 - 1.2. Because the foam of test **bench seat** cushion will compress after installation of the Child Restraint **System**, the dynamic test must be conducted no more than 10 minutes after installation as possible. To allow the **test bench seat** cushion to recover, the minimum period between two tests using the same **test bench seat** cushion shall be 20 minutes.

¹ In the case of restraints fitted with devices intended to increase the top tether tension, the test method shall be: install the ISOFIX child restraint system as required in this Annex and then apply the tensioner device as stated in the manufacturer's instructions. If the device cannot be applied due to excess tension then it is deemed to be an unacceptable device.

[Annex 19

Geometrical dimensions of @-Size Child Restraint Systems

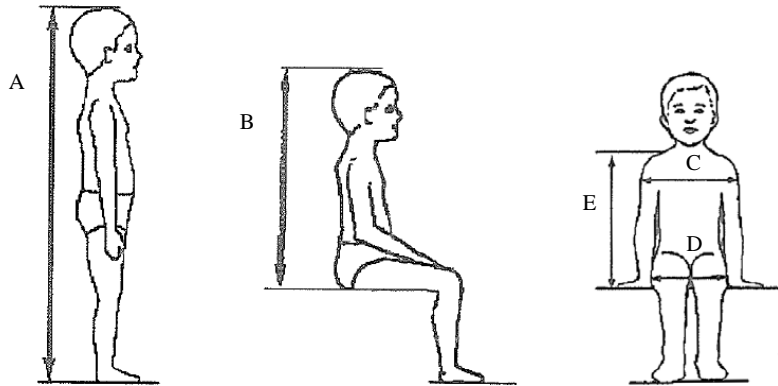

<i>Stature cm</i>	<i>Sitting height cm</i>	<i>Shoulder breadth cm</i>	<i>Hip breadth cm</i>	<i>Shoulder height cm</i>	
A	B	C	D	E	
	95%ile	95%ile	95%ile	5%ile	95%ile
40	NA	10.5	NA	TBD	TBD
45	NA	12.1	NA	TBD	TBD
50	NA	13.5	NA	TBD	TBD
55	NA	16.3	NA	TBD	TBD
60	45.0	18.0	17.6	TBD	TBD
65	45.0	19.3	17.0	28.8	29.2
70	48.0	21.9	18.9	28.4	29.9
75	49.5	25.4	20.5	28.4	31.0
80	51.8	27.0	21.4	29.3	32.7
85	53.6	27.4	22.2	30.7	34.3
90	55.2	28.4	22.2	31.8	35.2
95	57.7	28.9	23.0	30.8	36.2
100	60.1	29.0	23.1	32.6	37.2
105	62.6	29.7	24.9	33.5	39.2
110	64.3	30.4	26.6	34.2	40.0

<i>Stature cm</i>	<i>Sitting height cm</i>	<i>Shoulder breadth cm</i>	<i>Hip breadth cm</i>	<i>Shoulder height cm</i>	
A	B	C	D	E	
	95%ile	95%ile	95%ile	5%ile	95%ile
115	66.5	32.3	27.3	35.2	40.8
120	68.3	33.3	28.6	37.0	42.8
125	69.5	34.3	29.9	38.1	44.3
130	72.0	36.1	32.1	38.9	46.3
135	74.0	37.1	33.1	41.2	47.8
140	75.0	37.4	35.0	42.8	49.6
145	78.5	39.6	36.7	44.3	51.5
150	80.0	39.7	36.3	46.5	52.8

When measured under a contact force of 50 N with the device described in figure xx the following tolerances will be applied to the dimensions:

Minimum Sitting height: B-5%,

Minimum Shoulder breadth: C $_{-0}^{+2}$ cm

Minimum Hip breadth: D $_{-0}^{+2}$ cm

Minimum Shoulder height (5%ile): E1 $_{-2}^{+0}$ cm

Maximum shoulder height (95%ile): E2 $_{-0}^{+2}$ cm

Figure XX

