

Attachment 17**TECHNICAL STANDARD
FOR FUEL LEAKAGE IN COLLISIONS, ETC.**

1. Scope

This standard shall apply to the fuel tanks and fuel lines (gas containers, piping, and other devices on the hydrogen gas flow passage in the case of motor vehicles fueled by compressed hydrogen gas. Hereinafter the same.) of ordinary-sized motor vehicles exclusively for carriage of passengers, small-sized motor vehicles or mini-sized motor vehicles (except motor vehicles with a passenger capacity of 11 persons or more, motor vehicles with a gross vehicle weight of more than 2.8 tons, motor cycles with or without sidecars and mini-sized motor vehicles with caterpillar tracks and sleds).

2. Definitions

Those terms that appear in this technical standard have been defined as follows.

2-1 The “barrier” means a wall surface, against which a test vehicle is collided during frontal-impact tests.

2-2 The “impactor” means an impacting element which is collided against the rear-end of a test vehicle during rear-end impact tests.

3. Test procedure

3-1 Frontal-collision test

3-1-1 Test equipment

3-1-1-1 Barrier

The barrier shall be built of iron-reinforced concrete. Moreover, it shall be so constructed that it has sufficient weight and structure capable of withstanding the impacts caused by the test vehicle collision. The barrier face shall be 1.5 m or more in height and 3 m or more in width and right angle to the final approach path. In addition, the final approach path shall be flat and horizontal from the impacting surface of the barrier to a point about 5 m in front of the impacting surface.

Furthermore, the barrier frontal face shall be covered with about 20 mm-thick plywood board.

Moreover, it is permissible to install a steel sheet for the purpose of protecting the barrier or a load meter between the barrier and the plywood board.

3-1-2 Test vehicle conditions

3-1-2-1 The weight of the test vehicle shall be equivalent to or more than the vehicle weight. However, in the case of a motor vehicle equipped with spare tire and tools, etc., the test may be conducted with these accessories attached on the test vehicle.

3-1-2-2 As for those parts mounted on the test vehicle, it is permissible to use those other than genuine parts or to remove them, except for those parts with the possibility of interfering with the fuel tank and fuel line.

3-1-2-3 A fuel substitute liquid shall be used. This shall have such viscosity and specific gravity similar to those of the fuel used. In the case of motor vehicles fueled by compressed hydrogen gas, helium shall be used as substitute gas.

3-1-2-4 The fuel level of the fuel tank shall not be less than 90% of the rated fuel tank capacity. In the case of motor vehicles fueled by compressed hydrogen gas, the gas tank shall be filled with helium to 90% or more of the general-use pressure (referring to the general-use pressure in Paragraph 2-4 of Attachment 100 “Technical Standard for Fuel Systems of Motor Vehicles Fueled by Compressed Hydrogen Gas”).

3-1-2-5 It is permissible for systems other than the fuel tank and fuel lines to be empty.

3-1-2-6 In the case of motor vehicles fueled by compressed hydrogen gas, the main stop valve of the test vehicle and cutoff valves, etc. located in the downstream piping shall be kept open, immediately prior to the collision.

3-1-2-7 In the case of motor vehicles fueled by compressed hydrogen gas, without a system to close the main stop valve and other valves automatically at the time of the collision to shut off the fuel supply, the main stop valve and other valves shall be opened immediately if these valves are closed after the collision.

3-1-2-8 Motor vehicles fueled by compressed hydrogen gas, with a system

to close the main stop valve and other valves automatically at the time of the collision to shut off the fuel supply may be set in such a way that this system operates. In cases where the measurement of the pressure inside the gas container is interfered due to the fact that any valve is closed after the collision, it shall be opened when the pressure is measured, or a pressure sensor or a temperature sensor for the measurement shall be attached, as required.

3-1-3 Test procedure

The test vehicle shall be collided head-on against the frontal surface of the barrier at a speed of 50 ± 2 km/h. In this case, the lateral deviation between the median longitudinal plane of the test vehicle struck and the median plane of the barrier shall not exceed 300 mm. Also, measure the amount of fuel flowing out or dripping from various parts of the test vehicle to the outside. This measurement of the amount of fuel leakage shall be started as soon after the collision as possible and shall be performed for a period of 5 minutes. In the case of motor vehicles fueled by compressed hydrogen gas, the pressure and temperature of the gas shall be measured inside the gas container or at the upstream of the first pressure-reducing valve located downstream of the gas container, immediately before the collision and 60 minutes after the collision.

3-2 Rear-end collision test

3-2-1 Test equipment

3-2-1-1 Testing ground

The road surface on which the collision of the test vehicle and its movement take place shall be a dry, horizontal, flat paved road surface.

3-2-1-2 Impactor

The impactor shall be of steel and be of rigid construction. The impacting surface shall be flat. It shall measure at least at 800 mm in height and at least 2.5 m in width. Furthermore, its edges shall be rounded to a radius of 50 mm or less. In addition, its front face shall be covered with about 20 mm-thick plywood board. The ground clearance of the lower edge of the impacting surface shall be 175 ± 25 mm.

The impactor may either be secured to a carriage moving straight using the installation method prescribed in Paragraph 3-2-1-2-1 or be attached to a pendulum using the installation method prescribed in Paragraph 3-2-1-2-2.

3-2-1-2-1 Requirements for use of carriage

- (1) The carriage shall have adequate rigidity and shall not be deformed by the impact.
- (2) The carriage shall not be restrained during the collision. Moreover, upon completion of the collision, the carriage shall no longer have any further propelling force. The carriage may be equipped with a braking device to prevent re-collision.
- (3) The total mass of the carriage and impactor shall be $1,100 \pm 20$ kg.

3-2-1-2-2 Requirements for use of pendulum

- (1) The pendulum and the attached section of the pendulum impactor shall have adequate rigidity and shall not be deformed by the impact.
- (2) The distance between the centre of the impacting face and the axis of rotation of the pendulum shall be 5 m or more.
- (3) The reduced mass “Mr” at the centre of percussion of the pendulum shall be $1,100 \pm 20$ kg.

“Mr” is calculated by the equation below.

$$Mr = M \times L/A$$

where:

M : Total mass of pendulum (kg)

L : Distance between the centre of percussion and the axis of rotation (m)

A : Distance between the centre of gravity and the axis of rotation (m)

- (4) The pendulum shall be equipped with a braking device to prevent any secondary impact.

3-2-2 Speed measuring equipment

The speed measuring equipment used to measure the speed prescribed in Paragraph 3-2-3 shall be capable of measuring the speed of the impact with an accuracy of within one percent of the true value.

3-2-3 Test vehicle conditions

The same as with Paragraph 3-1-2.

3-2-4 Test procedure

With the test vehicle placed under the stationary state in the testing ground, the impactor shall be collided against the rear-end of the test vehicle horizontally and also in a direction parallel to the median longitudinal plane of the test vehicle at a speed of 50 ± 2 km/h. In this case, the lateral deviation between the median longitudinal plane of the test vehicle struck and the median plane of the impactor shall not exceed 300 mm. Also, measure the amount of fuel flowing out or dripping from various parts of the test vehicle to the outside. This measurement of the amount of fuel leakage shall be started as soon after the collision as possible and shall be performed for a duration of 5 minutes. In the case of motor vehicles fueled by compressed hydrogen gas, the pressure and temperature of the gas shall be measured inside the gas container or at the upstream of the first pressure-reducing valve located downstream of the gas container, immediately before the collision and 60 minutes after the collision.

4. Requirements

When subjected to the test prescribed in paragraphs 3-1 and 3-2 above, the amount of fuel flowing out or dripping from various parts of the test vehicle to the outside shall not exceed 30 g for the first one minute and also shall not exceed 150 g for a period of 5 minutes. In the case of motor vehicles fueled by compressed hydrogen gas, the rate of hydrogen gas leakage measured by the following procedure shall not exceed 131 NL per minute:

- (1) The helium gas pressure inside the gas container or at the upstream of the first pressure-reducing valve located downstream of the gas container, immediately before the measured collision and 60 minutes after the collision, shall be converted to the pressure at 0 °C.

$$P_0' = P_0 \times [273 / (273 + T_0)]$$

where:

P_0' : Helium gas pressure converted to pressure at 0 °C immediately before collision is conducted (MPa abs)

P_0 : Measured helium gas pressure immediately before collision is conducted (MPa abs)

T_0 : Measured helium gas temperature immediately before collision is conducted (°C)

$$P_{60}' = P_{60} \times [273 / (273 + T_{60})]$$

where:

P_{60}' : Helium gas pressure converted to pressure at 0 °C 60 minutes after collision (MPa abs)

P_{60} : Measured helium gas pressure 60 minutes after collision (MPa abs)

T_{60} : Measured helium gas temperature 60 minutes after collision (°C)

- (2) The gas density immediately before the collision is conducted and 60 minutes after the collision shall be calculated, respectively, using the pressure at 0 °C converted from the helium gas pressure inside the gas container or at the upstream of the first pressure-reducing valve located downstream of the gas container, immediately before the collision is conducted and 60 minutes after the collision, which have been obtained in Item (1).

$$\rho_0 = -0.00621 \times (P_0')^2 + 1.72 \times P_0' + 0.100$$

where:

ρ_0 : Helium gas density immediately before collision is conducted (kg/m³)

$$\rho_{60} = -0.00621 \times (P_{60}')^2 + 1.72 \times P_{60}' + 0.100$$

where:

ρ_{60} : Helium gas density 60 minutes after collision (kg/m³)

- (3) The helium gas volume immediately before the collision is conducted and 60 minutes after the collision shall be calculated, respectively, using the gas density obtained in Item (2), provided that the internal volume shall be the internal volume of the gas container in cases where the

helium gas pressure has been measured inside the gas container; and the internal volume of the gas container down to the upstream of the first pressure-reducing valve located downstream of the gas container in cases where the helium gas pressure has been measured at the upstream of the first pressure-reducing valve located downstream of the gas container.

$$Q_0 = \rho_0 \times V \times (22.4 / 4.00) \times 10^{-3}$$

where:

Q_0 : Helium gas volume immediately before collision is conducted (m³)

V : Internal volume (L)

$$Q_{60} = \rho_{60} \times V \times (22.4 / 4.00) \times 10^{-3}$$

where:

Q_{60} : Helium gas volume 60 minutes after collision (m³)

V : Internal volume (L)

- (4) The rate of helium gas leakage shall be calculated.

$$\Delta Q = (Q_0 - Q_{60}) \times 10^3$$

$$R_{He} = \Delta Q / 60$$

where:

ΔQ : Volume of helium gas leakage 60 minutes after collision (NL)

R_{He} : Rate of helium gas leakage (NL/min)

- (5) The rate of helium gas leakage shall be converted to the rate of hydrogen gas leakage.

$$R_H = 1.33 \times R_{He}$$

where:

R_H : Rate of hydrogen gas leakage (NL/min)

Attachment 38**MEASUREMENT PROCEDURE FOR
PROXIMITY STATIONARY NOISE LEVEL**

1. Scope

This measuring procedure shall apply to the measurement of the proximity stationary noise level of motor vehicles (except trailers) and motor driven cycles (hereinafter simply referred to as “motor vehicles” unless specifically specified).

2. Test Vehicle Conditions

The test vehicle shall be under the following conditions.

- (1) The test vehicle shall be in a serviced condition as set forth in the applicable maintenance service procedure.
- (2) The test vehicle shall be warmed up thoroughly by running it at appropriate speed.

3. Adjustment, etc. of Test Equipment, etc.

3-1 Noise measuring devices

3-1-1 Noise level meter, etc.

- (1) The noise measuring device refers to either of the following. The device shall be fully warmed up and calibrated before its use.
 - ① The noise level meter shall comply with the requirements set forth in the JIS C 1505-1988 “Precision Noise level meters”, or have the equivalent performance.
 - ② The sound level meter shall comply with the technical requirements prescribed in Item (4), Paragraph 1, Article 57 of the Enforcement Regulations for Road Vehicles Act.
- (2) The characteristics of the frequency compensating circuit shall be “A” characteristics.
- (3) The dynamic characteristics of the indicating mechanism shall be “fast dynamic characteristics (FAST)” if the noise level meter has the “fast dynamic characteristics (FAST).”

3-1-2 Engine tachometer

The engine tachometer shall be a tachometer other than that mounted on the test vehicle.

3-1-3 Automatic recording device

When an automatic recording device is used, the dynamic characteristics of the automatic recording device shall be in the same conditions as those specified in Item (3) of 3-1-1.

3-2 Microphone

The noise level meter microphone shall be placed in the positions and directions specified in each of the following Items given below. Moreover, the microphone must be equipped with a windscreen. The position of the microphone refers to the center position of the microphone's front side. If the microphone manufacturer gives special instructions regarding the direction of the microphone, such instructions shall be observed.

- (1) The position of the microphone shall be M1 in the Figure, a point 0.5 meter away from the outlet center of the exhaust pipe (in cases where the outlet of the exhaust pipe is directed upwards, from the outermost surface of the test vehicle which is nearest to the outlet on a vertical plane which is perpendicular to the longitudinal center line of the test vehicle and includes the outlet's center) on a vertical plane which includes the center of the exhaust pipe outlet and is intersected with a vertical plane, including the direction of the exhaust stream, at an angle of 45 ± 10 degrees outwards and backwards (in cases where the outlet of the exhaust pipe (hereinafter referred to as "the outlet") is directed upwards (referring to cases where the angle of the outlet to the vertical line is 30 degrees or less), M2 in Figure). Moreover, the height of the microphone shall be within ± 0.025 meters of the height of the outlet's center (0.2 meters above the ground level in cases where the height of the outlet's center is less than 0.2 meters above the ground level).
- (2) If any part of the test vehicle constitutes a hindrance and prevents the microphone from being installed at the position prescribed in the preceding Item, the position of the microphone shall be at a point which is 0.5 ± 0.025 meters from the outlet's center and is the nearest installable position to the point prescribed in the preceding Item (except those positions affected by the exhaust gas streams or positions whose height above ground is less than 0.2 meter).

- (3) If the microphone can not be installed physically at the measuring position specified in the preceding Item, the microphone shall be positioned at the nearest possible position (excluding positions whose height above ground is less than 0.2 meter) to the measuring position concerned at the height of the center of the exhaust pipe outlet, within the range outside the vertical plane which includes the center of the exhaust pipe outlet and is intersected with a vertical plane, including the direction of the exhaust stream, at an angle of 45 degrees outwards and backwards and 0.5 meters away from the exhaust pipe outlet's center.
- (4) The direction of the microphone shall be held horizontally and be pointing towards the outlet's center. However, if the outlet is directed upwards (including the one having the inclination where the direction of the exhaust stream does not exceed approx. 30 degrees in relation to the vertical line of the exhaust pipe concerned), the microphone shall be directed upward.
- (5) If the test vehicle has plural outlets and the distance between the centers of the respective outlets exceeds 0.3 meters, the microphone shall be installed with each center of the respective outlets as the measuring object. If the distance between the centers of the outlets is 0.3 meter or less, the microphone shall be installed with the rearmost outlet as the measuring object (in cases where the test vehicle has plural rearmost outlets, the outermost outlet; in cases where the test vehicle has plural rearmost and outermost outlets, the uppermost outlet). In this case, a section where the exhaust gas is leaking shall be regarded as the outlet of the exhaust pipe.

4. Noise measuring site

The noise measuring site for the measurement of the proximity stationary noise level shall be an almost-flat place free from conspicuous sound-reflecting bodies, such as walls and guard rails, in the range approx. 2 meters from the external of the motor vehicle and microphone.

5. Measuring method, etc.

The measurement of the proximity stationary noise level shall be performed by the procedure prescribed in each of the following Items given below.

5-1 Conditions of motor vehicles

The motor vehicle shall be in a stopped state. The shift position of the transmission shall be in neutral and the clutch shall be in the engaged condition.

In the case of motor vehicles with the transmission which has no neutral shift position, the driving wheels shall be cleared from the ground.

5-2 Measurement procedure

The measurement shall be conducted by running the engine of the test vehicle for about five seconds in a unloaded state within $\pm 100 \text{min}^{-1} \{\text{rpm}\}$ of the engine speed at which 75% (50%, in the case of small-sized motor vehicles and mini-sized motor vehicles (limited to motor cycles) and motor-driven cycles whose engine speed exceeds 5,000 rpm when the maximum engine output is delivered) of the maximum engine output is delivered. Then release the accelerator pedal suddenly or close the throttle valve suddenly. Make the measurement by recording the maximum value of the motor vehicle noise level during this operation. For engines whose revolution speed is unstable owing to their engine construction, it is only required that the mean value of the revolution speeds is within the aforesaid revolution speed range. Furthermore, the engine revolution speed shall be measured by a tachometer (not the tachometer, mounted on the test vehicle).

Figure

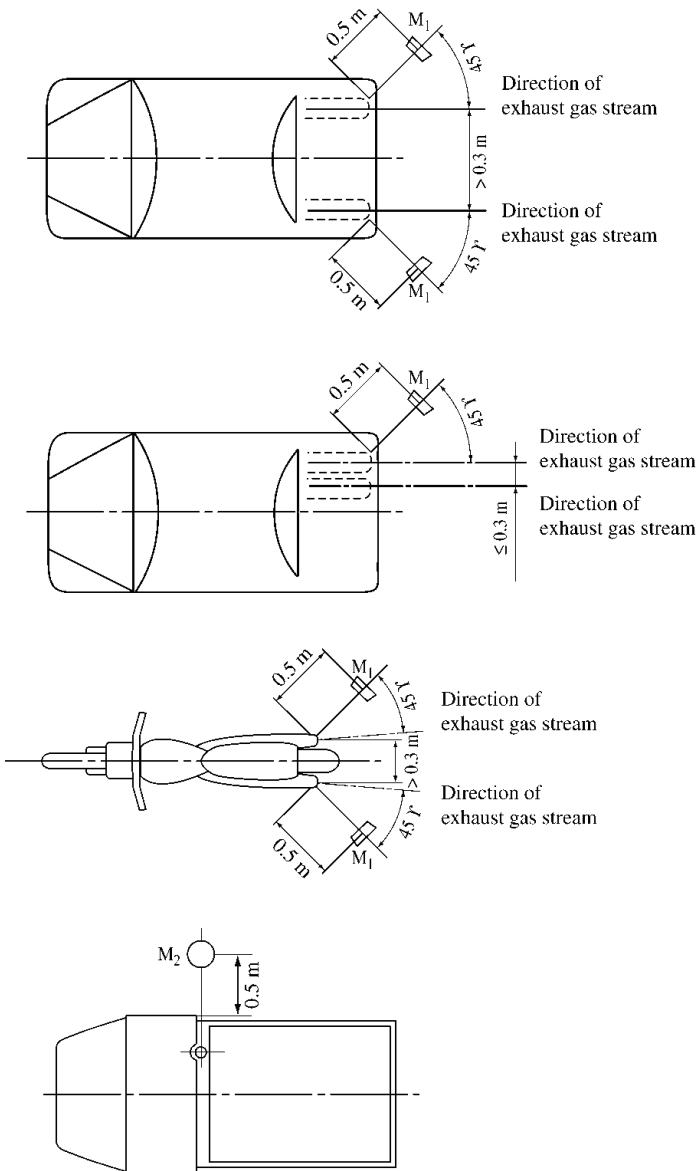

Case where the outlet of exhaust pipe is directed upwards

- M₁ : A point 0.5 ± 0.025 meter away from the outlet center on a vertical plane which includes the outlet's center and is intersected with a vertical plane, including the direction of the exhaust stream, at an angle of 45 ± 10 degrees outwards and backwards.
- M₂ : A point within 0.025 meters horizontally from the vertical line passing through a point 0.5 meter from the outermost surface of the test vehicle which is nearest to the outlet on a vertical plane which is perpendicular to the longitudinal center line of the test vehicle and includes the outlet's center.

Attachment 84**TECHNICAL STANDARD
FOR WINDSHIELD WIPING AND WASHING SYSTEMS
FOR PASSENGER MOTOR VEHICLES, ETC.**

1. Scope

This Technical Standard shall apply to the windshield wiping and washing systems of ordinary-sized vehicles used exclusively for carriage of passengers or a small-sized motor vehicles or mini-sized motor vehicles (except motor vehicles with a riding capacity of 11 persons or more, motor vehicles used for carriage of goods with a gross vehicle weight of more than 2.8 tons, motor vehicles which are used for carriage of goods and provided with a bulkhead between the driver's compartment and the passenger and freight accommodating compartments, thereby making it impossible for passengers to move across these compartments, motor vehicles used for carriage of goods with a riding capacity of three persons or less, motor cycles with or without sidecars, mini-sized motor vehicles with caterpillar tracks and sleds, motor vehicles with a maximum speed of less than 20 km/h, and trailers).

2. Definitions

2-1 "Cycle" means the forward and return movement of the windshield wiper.

2-2 "Zone A" and "Zone B" mean the respective areas that are determined in accordance with the Annex "Determining Procedure for Zones A and B" or the respective areas that are determined by means of plotting under conditions equivalent to the procedure above.

2-3 "Blade" means a part of the wiper that makes contact with the outside face of the glazed surface and wipes it.

2-4 "Arm" means a part of the wiper that holds the blade.

2-5 "Maximum speed" means the maximum speed posted in the Specification Table of the test vehicle, expressed in units of km/h.

2-6 "Having the injection capability" means that the windshield washing system concerned is capable of delivering a greater portion of the washing fluid to the section which is wiped by the windshield wiping system without leakage of the washing fluid from the hose when the washing system concerned is actuated by applying the test voltage or the pump operating force specified in

the right column of the Table 1 in accordance with the pump type of the washing system prescribed in the left column of the same table.

Table 1 Test voltage or pump operating force

Pump type	Test voltage or pump operating force
Electric type (12 V system)	12 ~ 14 V
Electric type (24 V system)	24 ~ 28 V
Hand-operated type	110 ~ 135 N
Foot-operated type	400 ~ 445 N

2-7 “Haying the plugging-withstanding characteristic” means that the windshield washing system concerned exhibits no detrimental defects, such as disconnected hoses, breakage or motor seizure, when the washing system is actuated at a rate of six frequencies in one minute (for at least 3 seconds each frequency), with all nozzles of the washing system plugged, by applying the test voltage or the pump operating force specified in the right column of the Table 1 in accordance with the pump type of the washing system pump prescribed in the left column of the same table.

2-8 “Washing fluid for low-temperature use” means a water solution, such as methyl alcohol, isopropyl alcohol or ethylene glycol.

2-9 “Manikin” means a manikin corresponding to a fiftieth percentile adult male which is provided for in JIS D 4607-1977 (Three Dimensional Manikins for Use in Defining Automobile Seating Accommodations) or ISO 6549-1980 (Road Vehicles Procedure for H-point Determination).

2-10 “R-point” means the hip point (pivotal axis of thigh) of a manikin or the equivalent design standard position set up on the seat when the manikin is seated in accordance with the seating procedure prescribed in JIS D 4607-1977 or ISO 6549-1980. In this case, the seats shall be adjusted to the following respective positions: in the case of a seat adjustable in a fore-and-aft direction, the rearmost position in design; in the case of a seat adjustable in an up-and-down direction, the lowest position; in the case of a seat, the angle of whose reclining section is adjustable, the design standard angle or the angular position at which the torso line (referring to a line representing the inclination of the torso) becomes as close to 25 degrees back from the vertical line as possible; and in the case of a seat having other adjusting mechanisms, the design standard position.

2-11 “Eyepoints” mean the two points which are located on a straight line which passes through a point 635 mm vertically above the R-point (hereinafter referred to as the “centre of eyepoints”) and is perpendicular to the central

plane of the motor vehicle. Furthermore, these two points, spaced 65 mm from each other, are located symmetrically in relation to the centre of the eyepoints.

2-12 “Fuel cell system” means a power generation system comprised of a fuel cell stack and an air supply system.

2-13 “Fuel cell stack” means a device which generates electricity directly by causing hydrogen to react chemically with oxygen.

3. Test Procedure

3-1 Windshield wiping system

3-1-1 General test conditions

- (1) The temperature of the test site shall be a normal temperature (between 5°C and 40°C), unless otherwise specified.
- (2) There shall be no specific rules for order in which the tests are to be carried out, except for the test of Paragraph 3-1-3, which shall be carried out last.

3-1-2 Sweep frequency test

The test shall be conducted, following the procedure given below:

- (1) Prior to the test, the outside face of the windshield of the test vehicle shall be cleaned so that no grease or foreign matter, etc. may remain on the glass surface.
- (2) Operate a water sprinkling system, until the test is completed, so that the entire outside face of the windshield is kept wet.
- (3) Start the engine (the fuel cell system in the case of fuel cell vehicles. Hereinafter referred to as the “power generation system”) of the test vehicle. The surrounding area of the engine of the test vehicle may be cooled by a cooling fan during the test. In this case, if the wiping system of the test vehicle is an electric type, the following conditions given below (except Item ① in the case of fuel cell vehicles) shall be satisfied:
 - ① The engine shall be in an unloaded state during the test. The revolution speed of the engine shall not exceed the speed calculated to be the speed at which the engine delivers its maximum power output (hereinafter the maximum output revolution speed)

multiplied by 0.3. In this case, if the test vehicle is equipped with an engine tachometer, the said tachometer may be used to measure the revolution speed of the engine.

- ② The headlamps of the test vehicle shall be turned ON and dipped;
 - ③ The controls of the air-conditioning devices (heating device, ventilating device and defroster, etc.) of the test vehicle shall be set to an operating position where maximum air flow is obtained. The devices shall be operated.
 - ④ If a defroster for the windshield glass, other than the air conditioning, is provided on the test vehicle, the device concerned shall be operated in such a way that its power consumption may become the maximum.
- (4) As a preliminary operation, operate the wiping system for at least 20 minutes at the lowest sweep frequency or speed (except the intermittent operation, hereinafter the same).

Then, set the wiping system to operate at the highest sweep frequency or speed. Measure the maximum sweep frequency per minute. (Here, one cycle is regarded as “one frequency.” Hereinafter the same.)

- (5) Next, switch the controls so that the wiping system operates at the lowest sweep frequency. Measure the minimum sweep frequency per minute. If the measured results fail to comply with the requirements provided for in Paragraph 4-1, it is permissible to measure the minimum sweep frequency with the wiping system set to the intermittent mode, provided that an intermittent mode wherein the sweep frequency is 10 frequencies or more per minute can be set in the wiping system.
- (6) Stop the operation of the wiping system. Confirm the blade position of the wiper.

3-1-3 Forced stalling test

The test shall be conducted, following the procedure given below:

- (1) Start the power generation system of the test vehicle. In this case, if the wiping system of the test vehicle is an electric type, the following conditions given below (except Item ① in the case of fuel cell vehicles) shall be satisfied:

- ① The engine shall be in an unloaded state during the test. The revolution speed of the engine shall not exceed a speed that is obtained when the maximum output revolution speed is multiplied by 0.3. In this case, if the test vehicle is equipped with an engine tachometer, the tachometer may be used to measure the revolution speed of the engine.
 - ② The headlamps of the test vehicle shall be turned ON and dipped;
 - ③ The controls of the air-conditioning devices (heating device, ventilating device and defroster, etc.) of the test vehicle shall be set to an operating position where maximum air flow is obtained. The devices shall be operated.
 - ④ If a defroster for the windshield glass, other than the air conditioning, is provided on the test vehicle, the device concerned shall be operated in such a way that its power consumption may become the maximum.
- (2) Operate the wiping system at the highest sweep frequency or speed. Restrain the wiper arm at the driver's seat side, for example, by seizing it by hand when the wiper is about to reverse its direction of movement after it has swung fully from the initial position. Hold the arm still for a duration of 15 seconds.
 - (3) Release the arm. Allow the wiping system to operate for a while and then turn it off. Confirm the blade position at this time. However, if a safety device (e.g. automatic circuit protecting device or circuit breaker) has been actuated and the operation of the wiping system stops while the arm was being seized, reset the safety device and allow the wiping system to operate for a while. Then turn off the wiping system. Confirm the blade position of the wiping system at this time.

3-1-4 Wiped area measurement test

The test shall be conducted, following the procedure given below:

- (1) Prior to the test, the outside face of the windshield of the test vehicle shall be cleaned and dried so that no grease or foreign matter, etc. may remain on the glass surface.
- (2) Draw contours of the Zones A and B on the inside face of the windshield.
- (3) Prepare a solution by mixing the components prescribed in the left

column of Table 2 in the respective volumetric ratio specified in the right column of the table. Apply this mixing solution evenly to the outside face of the windshield and allow the surface to dry. Or treat the outside face of the windshield, using a similar method.

Table 2 Components of mixing solution and volumetric ratio

Mixing solution components	Volumetric ratio (%)
Water having hardness of not more than 205 mg CaCO ₃ / l	92.5
Saturated salt water	5
Test dust of grade 7 or 8 test powder specified in JIS Z 8901, or test dust meeting requirements of Table 3 and Table 4	2.5

Table 3 Dust composition

Component	Mass ratio (%)
SiO ₂	67 ~ 69
Fe ₂ O ₃	3 ~ 5
Al ₂ O ₃	15 ~ 17
CaO	2 ~ 4
MgO	0.5 ~ 1.5
Total alkali	3 ~ 5
Ignition loss	2 ~ 3

Table 4 Mass distribution of grain size of coarse dust

Grain size (μm)	Mass distribution rate (%)
0 ~ 5	12 ± 2
5 ~ 10	12 ± 3
10 ~ 20	4 ± 3
20 ~ 40	23 ± 3
40 ~ 80	30 ± 3
80 ~ 200	9 ± 3

- (4) Start the power generation system of the test vehicle. In this case, if the wiping system of the test vehicle is of an electric type, the following conditions given below (except Item ① in the case of fuel cell vehicles) shall be satisfied:

① The engine shall be in an unloaded state during the test. The

revolution speed of the engine shall not exceed a speed that is obtained when the maximum output revolution speed is multiplied by 0.3. In this case, if the test vehicle is equipped with an engine tachometer, the tachometer may be used to measure the revolution speed of the engine.

- ② The headlamps of the test vehicle shall be turned ON and dipped;
 - ③ The controls of the air-conditioning devices (heating device, ventilating device and defroster, etc.) of the test vehicle shall be set to an operating position where maximum air flow is obtained. The devices shall be operated.
 - ④ If a defroster for the windshield glass, other than the air conditioning, is provided on the test vehicle, the device concerned shall be operated in such a way that its power consumption may become the maximum.
- (5) Operate the wiping system at the lowest sweep frequency for a duration not exceeding 10 cycles. In this case, water may be sprayed on the outside face of the windshield, using a spray, etc., but not to the extent that the dust is washed away by the force of the spray.
 - (6) Measure the area on the outside face of the windshield which can be perceived as having been wiped by the wiping system and which is enclosed by the respective contours of the Zones A and B in Item (2).

3-1-5 Low-temperature test

The test shall be conducted, following the procedure given below:

- (1) Prior to the test, the outside face of the windshield of the test vehicle shall be cleaned and dried so that no grease or foreign matter, etc. may remain on the glass surface.
- (2) The test vehicle, with the power generation system stopped, shall be conditioned in an environmental temperature of $-18 \pm 3^{\circ}\text{C}$ for at least 4 hours. However, if it is confirmed that the engine coolant and lubricant (the engine coolant, cooling oil or coolant of the fuel cell stack in the case of fuel cell vehicles) have stabilized at a temperature of $-18 \pm 3^{\circ}\text{C}$, this conditioning time may be shortened.
- (3) Start the power generation system of the test vehicle. However, the test may be conducted without operating the power generation system. In

this case, a voltage may be applied to the electrical system of the test vehicle by means of an external power supply. Moreover, if the wiping system of the test vehicle is of an electric type, the following conditions given below (except Item ① in the case of fuel cell vehicles) shall be satisfied:

- ① In cases where the engine of the test vehicle is operated, the engine shall be in an unloaded state during the test. The revolution speed of the engine shall not exceed a speed that is obtained when the maximum output revolution speed is multiplied by 0.3. However, this requirement shall not apply to cases where the revolution speed of the engine automatically rises owing to operation of an idle speed automatic adjusting device, etc. In this case, if the test vehicle is equipped with an engine tachometer, the tachometer may be used to measure the revolution speed of the engine.
 - ② In cases where voltage is applied to the electrical system of the test vehicle by means of an external power supply, the voltage concerned shall not exceed a voltage that is generated by the vehicle's own electric generator when the engine of the test vehicle is operated under the condition provided for in Item ① above. In the case of fuel cell vehicles, the voltage shall not exceed the voltage supplied during the normal running.
 - ③ The headlamps of the test vehicle shall be turned ON and dipped;
 - ④ The controls of the air-conditioning devices (heating device, ventilating device and defroster, etc.) of the test vehicle shall be set to an operating position whereby maximum air flow is obtained. The devices shall be operated.
 - ⑤ If a defroster for the windshield glass, other than the air conditioning, is provided on the test vehicle, the device concerned shall be operated in such a way that its power consumption may become the maximum.
- (4) Operate the wiping system at the highest sweep frequency for 2 minutes or more. Observe the operating conditions at this time.

3-1-6 Sweep performance test during high-speed running

The test shall be conducted, following the procedure given below. The test may be carried out by running the test vehicle on a proving ground or in a wind tunnel.

- (1) Prior to the test, the outside face of the windshield of the test vehicle shall be cleaned and dried so that no grease or foreign matter, etc. may remain on the glass surface.
- (2) Draw the contour of Zone A on the inside face of the windshield.
- (3) Prepare a solution by mixing the components prescribed in the left column of the Table 2 in the respective volumetric ratio specified in the right column of the table. Apply this mixing solution evenly to the outside face of the windshield (it is only required to include Zone A) and allow the surface to dry. Or treat the outside face of the windshield, using a similar method.
- (4) Run the test vehicle at a speed of $80\% V_{MAX}$ (referring to a speed that is obtained when the maximum speed is multiplied by 0.8. However, 120 shall be the upper limit) ± 5 km/h. Or place the test vehicle in a wind tunnel and set the relative wind velocity at the windshield to the same value as the running conditions prescribed above. Furthermore, in cases where the test vehicle is ran on a proving ground, the speedometer mounted on the test vehicle may be used to measure the vehicle speed. Also, in cases where the mean wind velocity in the running direction of the test vehicle exceeds 5 m/s, the running speed shall be adjusted so that the relative wind velocity at the windshield becomes a speed of $80\% V_{MAX} \pm 5$ km/h. In cases where the mean wind velocity in the direction perpendicular to the running direction of the test vehicle exceeds 5 m/s, in principle, no test shall be conducted. Moreover, in cases where the test is conducted by placing the test vehicle in a wind tunnel, a voltage may be applied to the electrical system of the test vehicle by means of an external power supply. In this case, the voltage concerned shall not exceed a voltage generated by the vehicle's own generator at a time when the test vehicle is running at a speed of $80\% V_{MAX} \pm 5$ km/h (the gear shift position of the transmission shall be the highest position suitable for running at a speed of $80\% V_{MAX} \pm 5$ km/h.). In the case of fuel cell vehicles, the voltage shall not exceed the voltage supplied to the electrical system of the windshield wipers when the test vehicle is running at a speed of $80\% V_{MAX} \pm 5$ km/h.
- (5) While the washing fluid (water) is being injected, operate the wiping system 5 cycles or more at the highest sweep frequency. At this time, visually observe the wiping condition of the wiping system from around the driver's seat.
- (6) Measure the area on the outside face of the windshield which can be

perceived as having been wiped by the wiping system and is enclosed by the contour of Zone A in Item (2).

3-2 Washing system

3-2-1 Test specimen

The test specimen will be a sample vehicle or a system in which the windshield washing system, wiping system, and windshield are mounted on a test bench in a way that is nominally used on the test vehicle. (The hoses and other equipment may be arranged in a coiled condition.)

3-2-2 General test conditions

The temperature of the test site shall be a normal temperature (between 5°C and 40°C), unless otherwise specified.

3-2-3 Washing capability test

The test shall be conducted, following the procedure given below:

- (1) Prior to the test, the outside face of the windshield of the test specimen shall be cleaned and dried so that no grease or foreign matter, etc. may remain on the glass surface.
- (2) Draw the contour of Zone A on the inside face of the windshield.
- (3) Prepare a solution by mixing the components prescribed in the left column of the Table 2 in the respective volumetric ratio specified in the right column of the table. Apply this mixing solution evenly to the outside face of the windshield and allow the surface to dry. Or treat the outside face of the windshield, using a similar method.
- (4) While the washing fluid (water) is being injected, operate the wiping system for a duration of not more than 10 cycles in succession.
If the wiping system is of a variable-frequency type, operate the wiping system at the highest sweep frequency. However, for a windshield washing system where the injection of the washing fluid (water) is interspersed with the wiper movement, the injection of the washing fluid may be suspended during the operation and afterwards the wiping system may be operated at the slowest sweep frequency.
- (5) Measure the area of the outside face of the windshield which can be perceived as having been washed and wiped by means of the windshield

washing system and wiping system and is enclosed by the contour of Zone A in Item (2). When evaluating the washing test results, the entire area (except for the section which can be perceived as an apparently non-washed section from around the eyepoints) shall be regarded as the washed area. Furthermore, the area covered by the dripping of the mixing solution occurring after the wiper operation shall not be regarded as a non-washed area.

3-2-4 Injection capability and plugging-withstanding tests

3-2-4-1 General rules

The tests prescribed in Paragraphs 3-2-4-2 through 3-2-4-7 shall be conducted on the same test specimen.

3-2-4-2 Plugging-withstanding test

Fill the reservoir of the washing system with water to the specified capacity. Place the washing system in an environmental temperature of $20 \pm 5^\circ\text{C}$ for a minimum of 4 hours. Afterward, verify the plugging-withstanding characteristic of the washing system. Next, verify the injection capability of the washing system.

3-2-4-3 Freezing strength test

The test shall be conducted, following the procedure given below:

- (1) Fill the reservoir of the washing system with water to the specified capacity. Place the washing system in an environmental temperature of $-18 \pm 3^\circ\text{C}$ for a minimum of 4 hours. Afterwards, operate the washing system at a rate of 6 times per minute (each time for at least 3 seconds).
- (2) Place the washing system in an environmental temperature of $20 \pm 5^\circ\text{C}$, until the ice in the washing system has completely thawed. Afterward, verify the injection capability of the washing system.

3-2-4-4 Freezing/thawing repetition test

The test shall be conducted, following the procedure given below:

- (1) Fill the reservoir of the washing system with water to the specified capacity. Place the washing system in an environmental temperature of

– $18 \pm 3^{\circ}\text{C}$ for a minimum of 4 hours so that all water in the reservoir of the washing system freezes.

- (2) Place the washing system in an environmental temperature of $20 \pm 5^{\circ}\text{C}$, until the ice in the washing system has completely thawed.
- (3) Repeat the freezing/thawing procedure provided for in Items (1) and (2) another 5 times. Afterward, verify the injection capability of the washing system.

3-2-4-5 Low-temperature operation test

Fill the reservoir of the washing system to the specified capacity with washing fluid for low-temperature use. Place the washing system in an environmental temperature of $-18 \pm 3^{\circ}\text{C}$ for a minimum of 4 hours. Then, verify the injection capability of the washing system at this environmental temperature.

3-2-4-6 High-temperature exposure test

The test shall be conducted, following the procedure given below:

- (1) Fill the reservoir of the washing system with water to the specified capacity. Place the washing system in an environmental temperature of $80 \pm 3^{\circ}\text{C}$ for a minimum of 8 hours.
- (2) Then, place the washing system in an environmental temperature of $20 \pm 5^{\circ}\text{C}$, until the water temperature has stabilized. Then, verify the injection capability of the washing system.

3-2-4-7 High-temperature operation test

Fill the reservoir of the washing system with water to the specified capacity. Place the washing system in an environmental temperature of $80 \pm 3^{\circ}\text{C}$ ($60 \pm 3^{\circ}\text{C}$, if no part of the washing system is located in the engine compartment) for a minimum of 8 hours. Then, verify the injection capability of the washing system at this environmental temperature.

4. Requirements

4-1 Wiping system

4-1-1 Sweep frequency test

When subjected to the test prescribed in Paragraph 3-1-2, the wiping system shall comply with the following requirements given below:

- (1) The maximum sweep frequency shall be 45 cycles or more per minute. Furthermore, the minimum sweep frequency shall be 10 cycles or more per minute.
- (2) The difference between the maximum sweep frequency and the minimum sweep frequency shall be 15 cycles or more per minute.
- (3) The blade position of the wiper shall automatically return to the initial position.

4-1-2 Forced stalling test

When subjected to the test prescribed in Paragraph 3-1-3, the wiping system shall continually function. Furthermore, when its operation stops, the blade position of the wiper shall automatically return to the initial position.

4-1-3 Wiped area measurement test

When subjected to the test prescribed in Paragraph 3-1-4, the area of the outside face of the windshield which can be perceived as having been wiped by means of the wiping system shall include 98% or more of Zone A and 80% or more of Zone B.

4-1-4 Low-temperature test

When subjected to the test prescribed in Paragraph 3-1-5, the wiping system shall function for at least 2 minutes.

4-1-5 Sweep performance test during high-speed running

When subjected to the test prescribed in Paragraph 3-1-6, the area of washing fluid in Zone A wiped by the wiping system, excluding parts missed owing to floating of the blade (except streaks of the washing fluid that remain during the wiping) shall include 98% or more of the area of Zone A.

4-2 Washing system

4-2-1 Washing capability test

When subjected to the test prescribed in Paragraph 3-2-3, the washing system shall be capable of delivering washing fluid in an adequate quantity so

that the area on the outside of the windshield which can be perceived as having been washed and wiped by the windshield washing system and wiping system is 60% or more of Zone A.

4-2-2 Injection capability and clogging-withstanding tests

When subjected to the respective tests prescribed in Paragraphs 3-2-4-2 through 3-2-4-7, the washing system shall have injection capability and plugging-withstanding characteristics (limited to the test in Paragraph 3-2-4-2 only).

ANNEX 1

**DETERMINING PROCEDURE
FOR “ZONE A” AND “ZONE B”**

1. Definitions

1-1 “Seatback angle” means the backward inclination angle of the torso reference line in the occupant seating condition. Therefore, the seatback angle means an angle of the torso line to the vertical line when the human manikin is seated in accordance with Paragraph 2-10 in this Technical Standard or the equivalent design standard angle.

1-2 “Point V1” and “Point V2” means the two representative vertical points when the results of distributions of eye positions of drivers are processed statistically. Point V1 and point V2 are those points which are determined when corrections in a fore-and-aft direction and in a vertical direction are made by the correction distance from the respective points that are determined as specified in Table 1 (hereinafter referred to as “the reference points”). Table 2 shows these correction distances in accordance with the seatback angle of the driver’s seat of the test vehicle.

Table 1 Positions of reference points

(Units: mm)

	Rearward of R-point	Vehicle outboard of R-point	Upward of R-point
Point V1	68	5	665
Point V2	68	5	589

Table 2 Correction distance from reference points

(Unit: mm)

Seat-back angle (degree)	Correction distance		Seat-back angle (degree)	Correction distance	
	Fore-and-aft direction	Up-and-down direction		Fore-and-aft direction	Up-and-down direction
5	- 186	+ 28	23	- 18	+ 5
6	- 177	+ 27	24	- 9	+ 3
7	- 167	+ 27	25	0	0
8	- 157	+ 27	26	+ 9	- 3
9	- 147	+ 26	27	+ 17	- 5
10	- 137	+ 25	28	+ 26	- 8
11	- 128	+ 24	29	+ 34	- 11
12	- 118	+ 23	30	+ 43	- 14
13	- 109	+ 22	31	+ 51	- 18
14	- 99	+ 21	32	+ 59	- 21
15	- 90	+ 20	33	+ 67	- 24
16	- 81	+ 18	34	+ 76	- 28
17	- 72	+ 17	35	+ 84	- 32
18	- 62	+ 15	36	+ 92	- 35
19	- 53	+ 13	37	+ 100	- 39
20	- 44	+ 11	38	+ 108	- 43
21	- 35	+ 9	39	+ 115	- 48
22	- 26	+ 7	40	+ 123	- 52

Note: Regarding prefixed signs of correction distances, the “+” sign represents a rearward direction or upward direction, whereas the “-” sign represents forward or downward direction.

2. Conditions of test vehicle

The conditions of the test vehicle shall mean conditions in which passengers of the riding capacity (assuming that the mass of each passenger of the riding capacity is 55 kg) are riding in the test vehicle in an unloaded state placed on a level floor or equivalent conditions. (In the case of a motor vehicle equipped with suspension units which make it possible to adjust the minimum ground clearance of the test vehicle, the suspension units shall be adjusted so that the minimum ground clearance is the design standard value.) Here, passengers are seated in the driver’s seat and, of other seats in parallel thereto, in the seat next to the side of the motor vehicle.

3. Determining procedure for “Zone A” and “Zone B”

3-1 Determining procedure for “Zone A”

In cases where the driver’s seat is located on the right side (including the centre) of the motor vehicle, Zone A means the area on the outside face of the windshield (limited only to the sections of the windshield which are not covered by glass retaining members or decorative members, and through which light can pass (hereinafter referred to as the “light transmitting section”) hereinafter the same) that is enclosed by the following four planes enumerated in Items (1) through (4) defined below. Furthermore, in cases where the driver’s seat is located at the left side, the “left side” shall read the “right side,” while the “right side” shall read the “left side” in the following Items (1) through (4).

- (1) A vertical plane passing through the point V1 and point V2 and at an angle of 13° to the right side of the longitudinal centre line of the motor vehicle;
- (2) A vertical plane passing through the point V1 and point V2 and at an angle of 20° to the left side of the longitudinal centre line of the motor vehicle;
- (3) A plane passing through the point V1 and at an upward angle of 3° from the horizontal plane;
- (4) A plane passing through the point V2 and at a downward angle of 1° from the horizontal plane.

3-2 Determining procedure for “Zone B”

In cases where the driver’s seat is located at the right side (including the centre) of the motor vehicle, Zone B means the area on the outside face of the windshield (except the sections within 25 mm from the outer edge of the light transmitting section of the windshield) that are enclosed by the following four planes enumerated in Items (1) through (4) defined below. Furthermore, in cases where the driver’s seat is located at the left side, the “left side” shall read the “right side,” while the “right side” shall read the “left side” in the following Items (1) through (4).

- (1) A vertical plane passing through the point V1 and point V2 and at an angle of 17° to the right side of the longitudinal centre line of the motor vehicle;
- (2) A plane symmetrical to the plane described in Item (1) in relation to the

vertical plane including the longitudinal centre line of the motor vehicle;

- (3) A plane passing through the point V1 and at an upward angle of 7° from the horizontal plane;
- (4) A plane passing through the point V2 and at a downward angle of 5° from the horizontal plane.

Attachment 86**TECHNICAL STANDARD
FOR DEFROSTING AND DEMISTING SYSTEMS**

1. Scope

This technical standard shall apply to the defrosting and demisting systems of an ordinary-sized motor vehicle used exclusively for carriage of passengers or a small-sized motor vehicle or a mini-sized motor vehicle (except motor vehicles with a riding capacity of 11 persons or more, motor cycles with or without sidecar, mini-sized motor vehicles with caterpillar and sled, motor vehicles with a maximum speed of less than 20 km/h and trailers).

2. Definitions

2-1 “Defrosting” means the elimination of frost or ice covering the glazed surface by the operation of the defrosting and demisting system (referring to the defroster set forth in Paragraph 2 of Article 45 of the Safety Regulations, not including the windshield wiper freeze preventing device. Hereinafter the same.) or the melting of the said frost or ice to such a degree that the windshield wipers can remove it or the removal of the said frost or ice by the windshield wipers.

2-2 “Defrosted area” means the area of the glazed surfaces having a dry surface or covered with frost or ice that has been melted by the operation of the defrosting system to such a degree that it can be removed by the windshield wipers or the area of the glazed surface from which the said frost or ice has been removed by the windshield wipers.

2-3 “Mist” means a film of minute water droplets which is formed when the water in the air is condensed on the inside face of the glazed surface.

2-4 “Demisting” means the elimination of the mist covering the inside face of the glaze surface by the operation of the demisting system.

2-5 “Demisted area” means the area of the glazed surfaces which has been demisted by the operation of the demisting system.

2-6 “Zone A” and “Zone B” mean the respective zones that are determined on the outside face of the windshield in accordance with the Annex, “Determining Procedure for Zones A and B,” of the Attachment 70, “Technical Standard for Windshield Wiping and Washing Systems for Passenger Motor Vehicles, etc.,” or the zones that are determined by means of plotting under

conditions equivalent to the procedure above.

2-7 “Human manikin” means a manikin corresponding to a fiftieth percentile adult male which is provided for in the JIS D 4607-1977 (Three Dimensional Manikins for Use in Defining Automobile Seating Accommodations) or the ISO 6549-1980 (Road Vehicles Procedure for H-point Determination).

2-8 “R-point” means the hip point (pivotal axis of thigh) of a human manikin or the equivalent design standard position set up on the seat when the human manikin is seated in accordance with the seating procedure prescribed in the JIS D 4607-1977 or ISO 6549-1980. In this case, the seats shall be adjusted to the following positions, respectively; in the case of a seat adjustable in a fore-and-aft direction, the rearmost position in design; in the case of a seat adjustable in an up-and-down direction, the lowest position; in the case of a seat, the angle of whose reclining section is adjustable, the design standard angle or the angular position at which the torso line (referring to a line representing the inclination of the torso) becomes as close to 25 degrees backward from the vertical line as possible; and in the case of a seat having other adjusting mechanisms, the design standard position.

2-9 “Fuel cell system” means a power generation system comprised of a fuel cell stack and an air supply system.

2-10 “Fuel cell stack” means a device which generates electricity directly by causing hydrogen to react chemically with oxygen.

3. Test Procedure

3-1 Defrosting performance test

3-1-1 General test conditions

- (1) The test shall be conducted in a low-temperature test chamber that is large enough to accommodate the test vehicle adequately and in which the chamber inner temperature is maintained at $-8 \pm 2^{\circ}\text{C}$. (This temperature shall be measured at a point not affected by the heat emitted from the test vehicle.) However, the test may be conducted in a test chamber whose temperature is maintained below the specified temperature.
- (2) A voltage may be applied by means of an external power supply device to the input terminal of the blower motor of the test vehicle during the test. However, the said voltage at the input terminal of the blower motor shall not exceed a voltage that is obtained when the nominal rating

voltage is multiplied by 1.2.

- (3) When the frost or ice that covered the outside face of the windshield glazed surface has melted during the test by means of the defrosting system, it is permissible to use the windshield wipers for the purpose of removing such melted frost or ice.

3-1-2 Conditions of test vehicle

- (1) Except for the fresh air inlet and outlet ports of the defrosting system, all of those devices of the test vehicle which can be opened or closed, such as the engine hood, doors, windows, luggage compartment, sunroof, canvas top and side vents, shall be in a closed state. Of those side windows at the driver's seat and seats parallel thereto, however, two windows may be opened, provided that the total height of the opened portions is within the upper limit of 25 mm.
- (2) The controls related to the air conditioner of the test vehicle shall be set to the following operating positions specified below:
 - ① Defroster mode;
 - ② Fresh air inlet or inner air recirculating mode;
 - ③ Maximum temperature;
 - ④ Maximum air flowrate.
- (3) If a defroster, other than the air conditioning, is provided, the device concerned shall be set to the operating position recommended by the manufacturer, etc.

3-1-3 Test procedure

The test shall be conducted, following the procedure given below.

- (1) Prior to the test, the outside face of the windshield of the test vehicle shall be cleaned and dried so that no grease or foreign matter, etc. may remain on the glaze surface.
- (2) Draw contours of the Zone A, a comparable zone of the windshield that is symmetrical with the Zone A in respect of the longitudinal centre line of the vehicle and Zone B on the inside face of the windshield.

- (3) The test vehicle, with the engine (the fuel cell system in the case of fuel cell vehicles. Hereinafter referred to as the “power generation system”) stopped, shall be soaked in the low-temperature test chamber whose temperature is kept at $-8 \pm 2^{\circ}\text{C}$ for at least 10 hours. However, if it is confirmed that the temperatures of the engine coolant and lubricant (the engine coolant, cooling oil or coolant of the fuel cell stack in the case of fuel cell vehicles) have stabilized at $-8 \pm 2^{\circ}\text{C}$, the soak time concerned may be shortened.
- (4) Apply an even and thin layer of ice whose ice mass is 44 mg/cm^2 per unit area over the entire outside face of the windshield by means of a waterspray gun whose operating pressure is $350 \pm 20 \text{ kPa}$. In this case, the spray nozzle of the waterspray gun shall be so adjusted that the maximum flowrate may be obtained. Furthermore, waterspray shall be applied from a point at a distance of between 200 and 250 mm from the outside face of the windshield. As regards a waterspray gun to be employed for the test, it shall have a nozzle of 1.7 mm diameter and a liquid flowrate of 0.395 r/min and capable of producing a spray pattern of approximately 300 mm width on the glazed surface when sprayed at a distance of approximately 200 mm from that surface, or it shall have an equivalent performance.
- (5) Again, the test vehicle, with the power generation system stopped, shall be placed in the low-temperature test chamber whose temperature is kept at $-8 \pm 2^{\circ}\text{C}$ for 30 to 40 minutes.
- (6) One or two inspectors shall enter the test vehicle and start the engine. (Here, the engine shall be in an unloaded state.) However, this engine starting may be performed by applying a voltage from the outside. In the case of fuel cell vehicles, either the fuel cell system is started or, when the test is conducted without operating the fuel cell system, a voltage, which does not exceed the voltage supplied during the normal running, is applied from the outside to the electrical system of the heat source of the defroster. Furthermore, the cooling air velocity in the test chamber shall be less than 2.2 m/s, when measured at a point approximately 300 mm forward of the lower edge of the windshield of the test vehicle and approximately at the same level as the mid-point of the windshield.
- (7) After the elapse of 5 minutes after the engine has started, the revolution speed of the engine shall not exceed a speed that is obtained when the engine speed at which the engine concerned delivers the maximum output (hereinafter the maximum output revolution speed) is multiplied by 0.5. (This provision shall not apply to fuel cell vehicles.) In this case, if the test vehicle is equipped with an engine tachometer, the said

tachometer may be used for the measurement of the revolution speed of the engine.

- (8) The inspector(s) shall draw the contour of the defrosted area on the inside face of the windshield when 20 minutes, 25 minutes and 40 minutes respectively have elapsed after the start of the power generation system or the start of the voltage application (hereinafter referred to as the “start of the power generation system, etc.”) according to Item (6). Furthermore, if all portions of the Zone B are defrosted within 40 minutes after the start of the power generation system, etc., the test may be terminated at this point.
- (9) After completion of the test, measure the areas of portions that are in the defrosted areas drawn in (8) and that are enclosed by the contours of the Zone A, the comparable zone of the windshield that is symmetrical with the Zone A in respect of the longitudinal centre line of the vehicle and Zone B in Item (2), respectively.

3-2 Demisting performance test

3-2-1 General test conditions

- (1) The test shall be conducted in a low-temperature test chamber that is large enough to accommodate the test vehicle adequately and in which the chamber inner temperature can be maintained at $-3 \pm 2^{\circ}\text{C}$ during the test. (This temperature shall be measured at a point not affected by the heat emitted from the test vehicle.) However, the test may be conducted in a test chamber whose temperature is maintained below the specified temperature.
- (2) A voltage may be applied by means of an external power supply device to the input terminal of the blower motor of the test vehicle during the test. However, the said voltage shall not exceed a voltage that is obtained when the nominal rating voltage is multiplied by 1.2.

3-2-2 Conditions of test vehicle

- (1) Except for the fresh air inlet and outlet ports of the demisting system, all of those devices of the test vehicle which can be opened or closed, such as the engine hood, doors, windows, luggage compartment, sunroof, canvas top and side vents, shall be in a closed state. Of those side windows at the driver’s seat and seats parallel thereto, however, two windows may be opened, provided that the total height of the opened portions is within the upper limit of 25 mm.

- (2) The controls related to the air conditioner of the test vehicle shall be set to the following operating positions specified below:
 - ① Defroster mode;
 - ② Fresh air inlet or inner air recirculating mode;
 - ③ Maximum temperature;
 - ④ Maximum air flowrate;
 - ⑤ Operation of the air conditioner stopped. However, cases where the operation of the air conditioner is interlocked with the demisting mode shall be excluded.
- (3) If a defroster, other than the air conditioning, is provided, the device concerned shall be set to the operating position recommended by the manufacturer, etc.

3-2-3 Test procedure

The test shall be conducted, following the procedure given below.

- (1) Prior to the test, the inside face of the windshield of the test vehicle shall be cleaned and dried so that no grease or foreign matter, etc. may remain on the glaze surface.
- (2) Draw contours of the Zones A and B on the outside face of the windshield.
- (3) The test vehicle, with the power generation system stopped, shall be preconditioned in the low-temperature test chamber whose temperature is kept at -3 ± 2 °C, until the engine coolant and lubricant (the engine coolant, cooling oil or coolant of the fuel cell stack in the case of fuel cell vehicles) have stabilized at the specified test temperature.
- (4) Place a steam generator provided for in the “Annex, Steam Generator” (hereinafter referred to as “the steam generator”) in such a way that its steam outlets in the longitudinal centre plane may come at a point 580 ± 80 mm above the R-point of the driver’s seat and the distance backward from the rear edge of the seatback of the driver’s seat adjusted to the design standard angle may be 200 mm or less. Furthermore, in the case of a motor vehicle having three rows or more of seats, another steam generator (hereinafter referred to as “the auxiliary steam generator”) may be placed so that its steam outlets in the longitudinal centre plane may

come at a point 580 ± 80 mm above the R-point of the driver's seat and at a point forward of the centre of the outboard seat in the third row. However, if it is impossible to position the steam generator or the auxiliary steam generator in the way described above because of the construction of the test vehicle, they may be positioned in the nearest convenient location to that prescribed above.

- (5) Operate the steam generator so that the steam generating rate per unit time may become $\{(70 \pm 5) \times (\text{Riding capacity})\}$ g/h. Furthermore, if the auxiliary steam generator is employed, the steam generating rate per unit time from a steam generator other than the auxiliary steam generator (hereinafter referred to as "the main steam generator") shall be $\{(70 \pm 5) \times (\text{Riding capacity} - \text{Riding capacity of seats at the third and following rows})\}$ g/h. Furthermore, the steam generating rate per unit time from the auxiliary steam generator shall be $\{(70 \pm 5) \times (\text{Riding capacity of seats at the third and following rows})\}$ g/h.
- (6) After the steam generator has been operating for 5 minutes, one or two inspectors shall enter the test vehicle. After this time onward, the steam generating rate per unit time of the steam generator shall be $\{(70 \pm 5) \times (\text{Riding capacity} - \text{Number of inspectors})\}$ g/h. Furthermore, if the auxiliary steam generator is employed, the steam generating rate per unit time from the main steam generator shall be $\{(70 \pm 5) \times (\text{Riding capacity} - \text{Riding capacity of seats at the third and following rows} - \text{Number of inspectors})\}$ g/h. Furthermore, the steam generating rate per unit time from the auxiliary steam generator shall be $\{(70 \pm 5) \times (\text{Riding capacity of seats at the third and following rows})\}$ g/h.
- (7) One minute after the inspector(s) have entered the test vehicle, start the engine. However, this engine starting may be performed by applying a voltage from the outside. In the case of fuel cell vehicles, either the fuel cell system is started or, when the test is conducted without operating the fuel cell system, a voltage, which does not exceed the voltage supplied during the normal running, is applied from the outside to the electrical system of the heat source of the defroster. Furthermore, the cooling air velocity in the test chamber shall be less than 2.2 m/s, when measured at a point approximately 300 mm forward of the lower edge of the windshield of the test vehicle and, approximately at the same level as the mid-point of the windshield.
- (8) The engine shall be in an unloaded state during the test. The revolution speed of the engine shall not exceed a speed that is obtained when the maximum output revolution speed is multiplied by 0.5. (This provision shall not apply to fuel cell vehicles.) In this case, if the test vehicle is

equipped with an engine tachometer, the said tachometer may be used for the measurement of the revolution speed of the engine.

- (9) Ten minutes after the start of the power generation system, etc. according to Item (7), the inspector(s) shall draw the contour of the demisted area on the outside face of the windshield. Furthermore, if all portions of the Zone B are demisted within 10 minutes after the start of the power generation system, etc., the test may be terminated at this point.
- (10) After completion of the test, measure the areas of portions that are in the demisted areas drawn in (9) and that are enclosed by the contours of the Zones A and B in Item (2), respectively.

4. Requirements

4-1 When subjected to the test of Paragraph 3-1, the defrosted area shall comply with the following requirements given below:

- (1) Twenty minutes after the start of the power generation system, etc. of the test vehicle, the defrosted area shall include 80% or more of the Zone A;
- (2) Twenty five minutes after the start of the power generation system, etc. of the test vehicle, the defrosted area shall include 80% or more of the comparable zone of the windshield that is symmetrical with the Zone A in respect of the longitudinal centre line of the vehicle;
- (3) Forty minutes after the start of the power generation system, etc. of the test vehicle, the defrosted area shall include 95% or more of the Zone B.

4-2 When subjected to the test of Paragraph 3-2, the demisted area shall comply with the following requirements given below:

- (1) Ten minutes after the start of the power generation system, etc. of the test vehicle, the demisted area shall include 90% or more of the Zone A.
- (2) Ten minutes after the start of the power generation system, etc. of the test vehicle, the demisted area shall include 80% or more of the Zone B.

ANNEX

STEAM GENERATOR

The steam generator to be employed for the demisting performance test of Paragraph 3-2 shall comply with the following constructional and performance requirements enumerated below:

- (1) The construction of the steam generator shall be similar to one indicated in the next illustration.
- (2) The heat loss at the boiling point of water in the steam generator shall not exceed 75 W in an ambient temperature of $-3 \pm 2^\circ\text{C}$.
- (3) The capacity shall be 2 liters or more.
- (4) The air delivery capacity of the centrifugal blower shall be 0.05 to 0.10 m^3/min at a static pressure of 50 Pa.
- (5) Six steam outlet holes, each measuring 6.0 to 6.5 mm in diameter, shall be provided around the top of the steam generator.
- (6) When filled with 1.5 liters or more of water, the steam generator shall be capable of generating steam in a stable manner at a rate of $\{(70 \pm 5) \times (\text{Riding capacity})\}$ g per hour.

Fig. Outline of Steam Generator

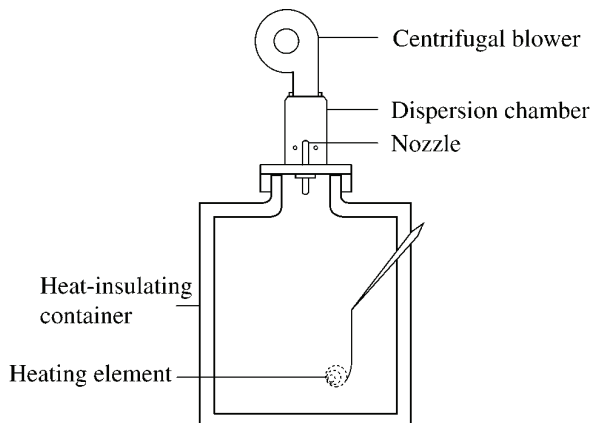

Attachment 100**TECHNICAL STANDARD FOR FUEL SYSTEMS OF
MOTOR VEHICLES FUELED BY COMPRESSED HYDROGEN GAS**

1. Scope

This Technical Standard shall apply to fuel systems (referring to the hydrogen system, fuel cell system, and other parts related to fuel as well as power generation by the fuel in fuel cell vehicles. Hereinafter the same.) of fuel cell vehicles fueled by compressed hydrogen gas (except motorcycles with or without sidecar).

2. Definitions

In addition to the definitions described in Article 1 of the Safety Regulations and Article 2 of the Announcement That Prescribes Details of Safety Regulations for Road Vehicles, the terms appearing in this Technical Standard shall be defined in the following Items 2-1 to 2-19.

2-1 “Hydrogen system” in fuel cell vehicles means devices related to filling, storage and supply of hydrogen gas in the line from the gas filling port to the inlet of the fuel cell stack, the components in the hydrogen circulation line where hydrogen returns from the outlet of the fuel cell stack to its inlet, as well as their controlling devices. In other motor vehicles, it means devices related to filling, storage and supply of hydrogen gas in the line from the gas filling port to the engine.

2-2 “Fuel cell system” means a power generation system comprised of hydrogen system, air-supply system, and fuel cell stack, as well as their controlling devices, including humidifiers for hydrogen gas and air, and temperature regulating device for the fuel cell stack.

2-3 “Fuel cell stack” means a device which generates power directly by causing hydrogen to react with oxygen.

2-4 “General-use pressure” means the highest pressure in the pressure commonly used.

2-5 “Pressure” means gauge pressure.

2-6 “Container main valve” means a valve attached directly to a gas container and shuts off the flow of hydrogen gas from the gas container.

2-7 “Main stop valve” means, among the container main valves, a valve that electromagnetically shuts off hydrogen gas supplied to the downstream of that valve.

2-8 “Container check valve” means, among the container main valves, a valve that prevents hydrogen gas from flowing backward from the gas container to the gas filling port.

2-9 “Container safety valve” means a valve, attached directly to the gas container, that is deployed only once to discharge hydrogen gas when the hydrogen gas temperature within the gas container rises abnormally high to the extent that the gas container may be damaged.

2-10 “Container attachments” mean a main stop valve, a container check valve and a container safety valve.

2-11 “Overflow prevention valve” means a valve that automatically shuts off hydrogen gas or regulates its flow when the flow of hydrogen gas from the gas container increases abnormally.

2-12 “Pressure reducing valve” means a valve that regulates pressure of hydrogen gas at designated levels.

2-13 “Safety device” means a device capable of preventing significant rise in pressure at the secondary side of the pressure-reducing valve.

2-14 “Pressure relief valve” means a valve that reduces pressure when the secondary pressure of the pressure reducing valve rises abnormally.

2-15 “Piping, etc.” mean components of the passage of hydrogen gas, excluding the fuel cell stack, engine, gas containers and container attachments.

2-16 “Gas filling port” means a connective opening installed on a vehicle for filling the gas container with hydrogen gas.

2-17 “Gas filling valve” means a valve for shutting off the flow of gas between the gas container and the gas filling port when the gas is not being filled.

2-18 “To purge” means to discharge a portion of hydrogen gas within the fuel cell system outside (excluding discharges from the container safety valve and pressure relief valve) by the control of the fuel cell system.

2-19 “Purge gas discharging section” means a discharging port for purged gas, usually having a pipe shape.

3. Requirements

3-1 Container attachments

3-1-1 Container attachments shall be attached directly to each gas container.

3-1-2 The main stop valve shall comply with each of the following Items 3-1-2-1 and 3-1-2-2.

3-1-2-1 The main stop valve that supplies and shuts off hydrogen gas shall be operable at the driver’s seat. The valve must operate without fail.

3-1-2-2 It shall be operated electromagnetically, and shall be closed automatically when the power source of its operation fails.

3-1-3 A container check valve shall be capable of preventing reverse flow at pressures ranging from the general-use pressure to the minimum pressure that is normally used.

3-1-4 Hydrogen gas discharged when the container safety valve is operated due to an abnormal rise in temperature of the gas container shall be emitted in the manners enumerated in each of the following Items 3-1-4-1 through 3-1-4-5.

3-1-4-1 Not emitting directly into the passenger compartment or luggage compartment;

3-1-4-2 Not emitting into the tyre housing;

3-1-4-3 Not emitting toward the exposed electrical terminals, electrical switches or other ignition sources;

3-1-4-4 Not emitting toward other gas containers; and

3-1-4-5 Not emitting toward the front of the motor vehicle.

3-2 Overflow prevention valve, etc.

3-2-1 Any of the devices that prevent one of the overflow enumerated in following Items 3-2-1-1 to 3-2-1-3 shall be provided.

3-2-1-1 An overflow prevention valve (installed on the main stop valve or in close proximity thereto);

3-2-1-2 A system consisting of a device that detects the pressure inside the gas container or piping, etc. and a main stop valve that shuts off the supply of hydrogen gas from the gas container when the aforementioned device detects an abnormal drop in pressure; and

3-2-1-3 A system consisting of a device that detects the flow rate of hydrogen gas inside the gas container or piping, etc. and a main stop valve that shuts off the supply of hydrogen gas from the gas container when the aforementioned device detects any abnormal rise in the flow rate.

3-3 Pressure-reducing valve

3-3-1 A pressure-reducing valve shall not be attached upstream of the main stop valve. However, this provision shall not apply to cases where the shut-off function is provided at the passage from the pressure-reducing valve to the atmosphere or where there is no passage leading to the atmosphere.

3-4 Safety device

3-4-1 A safety device capable of preventing significant rise in pressure at the secondary side of the pressure-reducing valve, that complies with the following Items 3-4-1-1 or 3-4-1-2, shall be provided. However, this provision shall not apply to cases where all components at the secondary side of the pressure-reducing valve (in cases where another pressure-reducing valve is provided at the secondary side, all components down to the pressure-reducing valve concerned) have pressure-resistant performance toward the pressure at the primary side of the pressure-reducing valve.

3-4-1-1 A pressure relief valve that operates at a pressure lower than the resistant pressure of the devices at the secondary side of the pressure-reducing valve when the pressure at the secondary side of the pressure-reducing valve exceeds the general-use pressure, and that has a discharge flow rate necessary for the protection of the devices at the secondary side.

3-4-1-2 A safety device consisting of a device that detects the pressure at the secondary side of the pressure-reducing valve, and a valve that shuts off the supply of hydrogen gas at the primary side of the pressure-reducing valve at a pressure lower than the resistant pressure of the devices at the secondary side of the pressure-reducing valve when the aforementioned device detects a

pressure higher than the general-use pressure.

3-4-2 Hydrogen gas discharged from the pressure relief valve shall be emitted in the manners enumerated in each of the following Items 3-4-2-1 through 3-4-2-3.

3-4-2-1 Not emitting directly into the passenger compartment or luggage compartment;

3-4-2-2 Not emitting into the tyre housing; and

3-4-2-3 Not emitting toward the exposed electrical terminals, electrical switches or other ignition sources.

3-5 Gas containers, piping, etc.

3-5-1 Gas containers, piping, etc. shall not be such one that is removed for filling the hydrogen gas.

3-5-2 Gas containers, piping, etc. shall not be provided in the passenger compartment, luggage compartment or other places where ventilation is not sufficient. However, this provision shall not apply to cases where the gas containers, piping, etc. are housed in a housing that complies with each of the following Items 3-5-2-1 through 3-5-2-3. (In the case of metal gas containers and gas containers with metal lining, it shall be acceptable if only the container attachments and their joint sections are housed.)

3-5-2-1 No gas leakage shall be present when subjected to the airtightness test of the housing pursuant to Paragraph 1 of Attached Sheet 1 "Airtightness and Ventilation Test."

3-5-2-2 A ventilation opening shall be provided for discharging leaked hydrogen gas. Furthermore, hydrogen gas shall be emitted in the manners enumerated in Items 3-5-2-2-1 through 3-5-2-2-3.

3-5-2-2-1 Not emitting directly into the passenger compartment or luggage compartment;

3-5-2-2-2 Not emitting toward the tyre housing; and

3-5-2-2-3 Not emitting toward the exposed electrical terminals, electrical switches or other ignition sources.

3-5-2-3 When subjected to the ventilation test of the housing pursuant to

Paragraph 2 of Attached Sheet 1 “Airtightness and Ventilation Test,” the time required for the gas concentration inside the housing to drop by 90% shall be within 180 seconds.

3-5-3 Gas containers and piping, etc. shall be securely installed so as to prevent shifting or damage while traveling, and sections thereof that is liable to damage shall be protected by covering. In the case where the natural frequency of the vertical, longitudinal and/or horizontal vibration of the gas container’s mounting part is 20 Hz or below, the part shall satisfy either of the Items 3-5-3-1 or 3-5-3-2 below in relation to the aforementioned vertical, longitudinal and/or horizontal vibration.

3-5-3-1 It shall meet the requirements of the Attached Sheet 18, “Technical Standards for Mounting Devices for Automotive-Use Fuel Gas Containers” (excluding the portion relating to the range of application).

3-5-3-2 It shall have the proven resistance against vibration equal to, or above, the resistance indicated in Item 3-5-3-1, calculated using the rate of acceleration measured by actual driving, including travel on rough road.

3-5-4 A gas container and container attachments in motor vehicles other than those for which Paragraph 3, Article 17 of the Safety Standards are applicable, shall be installed in a position where the horizontal distance from their front to the vehicle’s front end is not less than 420 mm on the line parallel to the vehicle’s median longitudinal line, and the horizontal distance from their rear to the vehicle’s rear end is not less than 300 mm on the line parallel to the vehicle’s median longitudinal line. The part attaching the gas container, when the container is filled with compressed hydrogen gas at the general-use pressure, must not be torn by acceleration toward the moving direction, indicated in Paragraphs 3-5-4-1 through 3-5-4-3 below for each type of motor vehicles. Conformity with the requirements as related to acceleration may be proven by calculation.

3-5-4-1 Motor vehicles used for carriage of goods with a gross vehicle weight of less than 3.5 t: $\pm 196 \text{ m/s}^2$

3-5-4-2 Motor vehicles exclusively for carriage of passengers, having a passenger capacity of 11 persons or more, with a gross vehicle weight of less than 5 t, or vehicles for carriage of goods with a gross vehicle weight of 3.5 t or more and less than 12 t: $\pm 98 \text{ m/s}^2$

3-5-4-3 Motor vehicles exclusively for carriage of passengers, having a passenger capacity of 11 persons or more, with a gross vehicle weight of 5 t or more, or vehicles for carriage of goods with a gross vehicle weight of 12 t

or more: $\pm 64.7 \text{ m/s}^2$

3-5-5 In cases where the test is conducted pursuant to Attachment 24 “Technical Standard for the Protection of the Occupants in the Event of a Lateral Collision” in order to judge the compliance with the said Technical Standard, based on the provisions of Paragraph 3 of Article 18 of the Safety Regulations, the said test shall be conducted according to Paragraphs 3-5-5-1 and 3-5-5-2, and motor vehicles whose seat is at a height of 700 mm or less above the ground (except motor vehicles used exclusively for carriage of passengers with a passenger capacity of 10 persons or more and motor vehicles similar in shape to motor vehicles used exclusively for carriage of passengers with a passenger capacity of 10 persons or more, motor vehicles used for the carriage of goods with a gross vehicle weight exceeding 3.5 t and motor vehicles similar in shape to motor vehicles used for the carriage of goods with a gross vehicle weight exceeding 3.5 t, three-wheeled motor vehicles, mini-sized motor vehicles with caterpillar tracks and sleds, large-sized special motor vehicles, small-sized special motor vehicles, and trailers) shall satisfy the requirements of Paragraph 3-5-5-3.

3-5-5-1 Conditions shall be in accordance with Paragraphs 3-5-5-1-1 through 3-5-5-1-4 given below:

3-5-5-1-1 The gas container shall be filled with helium to 90% or more of the specified general-use pressure.

3-5-5-1-2 The main stop valve and shut-off valves, etc. for hydrogen gas, located in the downstream gas piping, shall be kept open immediately prior to the collision.

3-5-5-1-3 Motor vehicles without a system to close the main stop valve and other valves automatically upon the collision to shut off the fuel supply shall open these valves immediately in the case when they were closed after the collision.

3-5-5-1-4 Motor vehicles having a system to close the main stop valve and other valves automatically upon the collision to shut off the fuel supply may be set in such a way that this system operates. In cases where the measurement of the pressure inside the gas container is interfered due to the fact that the valve is closed after the collision, it shall be opened when the pressure is measured or a pressure sensor or a temperature sensor for the measurement shall be attached, as required.

3-5-5-2 The pressure and temperature of the gas shall be measured inside the gas container or at the upstream of the first pressure-reducing valve

located downstream of the gas container, immediately before the collision and 60 minutes after the collision.

3-5-5-3 The rate of hydrogen gas leakage measured by the following procedure of Items 3-5-5-3-1 through 3-5-5-3-5 shall not exceed 131 NL per minute.

3-5-5-3-1 The helium gas pressure at the upstream of the first pressure-reducing valve within the gas container or the one located downstream of the gas container, immediately before the collision and 60 minutes after the collision, shall be converted to the pressure at 0°C.

$$P_0' = P_0 \times \{273 / (273 + T_0)\}$$

where:

P_0' : Helium gas pressure converted to pressure at 0 °C before collision (MPa abs)

P_0 : Measured helium gas pressure before collision (MPa abs)

T_0 : Measured helium gas temperature before collision (°C)

$$P_{60}' = P_{60} \times \{273 / (273 + T_{60})\}$$

where:

P_{60}' : Helium gas pressure converted to pressure at 0 °C 60 minutes after collision (MPa abs)

P_{60} : Measured helium gas pressure 60 minutes after collision (MPa abs)

T_{60} : Measured helium gas temperature 60 minutes after collision (°C)

3-5-5-3-2 The gas density before the collision and 60 minutes after the collision shall be calculated, respectively, using the pressure at 0°C converted from the helium gas pressure at the upstream of the first pressure-reducing valve within the gas container or the one located downstream of the gas container, immediately before the collision and 60 minutes after the collision, which have been obtained in Item 3-5-5-3-1.

$$\rho_0 = -0.00621 \times (P_0')^2 + 1.72 \times P_0' + 0.100$$

where:

$$\rho_0 \quad : \quad \text{Helium gas density before collision} \quad (\text{kg/m}^3)$$

$$\rho_{60} = -0.00621 \times (P_{60}')^2 + 1.72 \times P_{60}' + 0.100$$

where:

$$\rho_{60} \quad : \quad \text{Helium gas density 60 minutes after collision} \quad (\text{kg/m}^3)$$

3-5-5-3-3 The helium gas volume before the collision and 60 minutes after collision shall be calculated, respectively, using the gas density obtained in Item 3-5-5-3-2 above. However, the internal volume shall be the internal volume of the gas container in cases where the helium gas pressure has been measured inside the gas container; and the internal volume of the container down to the upstream of the first pressure-reducing valve located downstream of the gas container in cases where the helium gas pressure has been measured at the upstream of the first pressure-reducing valve located downstream of the gas container.

$$Q_0 = \rho_0 \times V \times (22.4 / 4.00) * 10^{-3}$$

where:

$$Q_0 \quad : \quad \text{Helium gas volume before collision} \quad (\text{m}^3)$$

$$V \quad : \quad \text{Internal volume} \quad (\text{L})$$

$$Q_{60} = \rho_{60} \times V \times (22.4 / 4.00) * 10^{-3}$$

where:

$$Q_{60} \quad : \quad \text{Helium gas volume 60 minutes after collision} \quad (\text{m}^3)$$

$$V \quad : \quad \text{Internal volume} \quad (\text{L})$$

3-5-5-3-4 The rate of helium gas leakage shall be calculated.

$$\Delta Q = (Q_0 - Q_{60}) \times 10^3$$

$$R_{He} = \Delta Q / 60$$

where:

ΔQ : Volume of helium gas leakage 60 minutes after collision (NL)

R_{He} : Rate of helium gas leakage (NL/min)

3-5-5-3-5 The rate of helium gas leakage shall be converted to the rate of hydrogen gas leakage.

$$R_H = 1.33 \times R_{He}$$

where:

R_H : Rate of hydrogen gas leakage (NL/min)

3-5-6 Container attachments must be installed at a distance not less than 200 mm from the vehicle's external end in the proximity (excluding rear end). The part attaching the gas container, when the container is filled with compressed hydrogen gas and at the general-use pressure, must not be torn by acceleration toward the horizontal direction perpendicular to the moving direction, indicated in Paragraph 3-5-6-1 or 3-5-6-2 below for each type of motor vehicles. Conformity with the requirements as related to acceleration may be proven by calculation. Moreover, the requirement of Paragraph 3-5-6-1 shall not apply to motor vehicles to which Paragraph 3-5-5 is applicable. Furthermore, with regard to the side where the test is conducted, it shall be permissible even if the container attachments are not installed at a distance not less than 200 mm from the vehicle's external end in the proximity (excluding the rear end).

3-5-6-1 Motor vehicles exclusively for carriage of passengers, having a passenger capacity of 9 persons or less, or vehicles for carriage of goods with a gross vehicle weight of less than 3.5 t: $\pm 78.4 \text{ m/s}^2$

3-5-6-2 Motor vehicles exclusively for carriage of passengers, having a passenger capacity of 10 persons or more, or vehicles for carriage of goods with a gross vehicle weight of 3.5 t or more: $\pm 49 \text{ m/s}^2$

3-5-7 Metal parts of the supporting fixtures for the piping shall not be in direct contact with the piping. However, this provision shall not apply to cases where the piping is soldered or welded to the supporting fixtures.

3-5-8 Gas piping with both ends secured shall have an appropriate bend at

its midpoint, and shall be supported at an interval of 1 m or less.

3-5-9 Gas containers, piping, etc. that may be affected significantly by the heat of the exhaust pipes, mufflers, etc., shall be protected by appropriate heat-insulating measures. Moreover, gas containers exposed to direct sunlight shall be provided with an adequate cover or other adequate sunshade.

3-6 Gas filling port

3-6-1 The gas filling port shall be provided with a gas filling valve having overflow prevention function.

3-6-2 A gas filling port shall comply with the requirements enumerated in each of the following Items 3-6-2-1 through 3-6-2-3.

3-6-2-1 The gas filling port shall be installed at a position where filling can be performed easily.

3-6-2-2 The gas filling port shall not be installed in the passenger compartment, luggage compartment and other places where ventilation is not sufficient.

3-6-2-3 The gas filling port shall be located at least 200 mm away from exposed electrical terminals, electrical switches, and other ignition sources.

3-7 Airtightness, etc. of piping, etc.

3-7-1 Piping, etc. shall be durable and sturdy, with airtightness from external atmosphere under general-use pressure, allowing no gas leakage when tested for airtightness of piping, etc. pursuant to Paragraph 3 of the Attached Sheet 1, "Airtightness and Ventilation Test".

3-7-2 Piping, etc. from the gas filling port to the first pressure-reducing valve in the downstream of the gas container shall be durable and sturdy, having, in addition to the requirement prescribed in 3-7-1 above, the pressure resistance 1.5 times the general-use pressure, taking into account the embrittlement caused by hydrogen.

3-8 Purge

3-8-1 In fuel cell vehicles that discharge gas containing hydrogen purged from the fuel cell system into the atmosphere, the purged gas in excess of 4% of hydrogen concentration shall not be discharged or leak to the atmosphere.

3-8-2 In fuel cell vehicles that discharge gas containing hydrogen purged from the fuel cell system into the atmosphere, as for the hydrogen concentration of the purged gas at time of discharge into the atmosphere, the maximum hydrogen concentration obtained according to the method specified in Attached Sheet 2 "Measurement of Hydrogen Concentration of Purged Gas at Time of Discharge" shall not exceed 4%.

3-9 Detection of hydrogen gas leakage, etc.

3-9-1 At least one detector of hydrogen gas leakage (hereinafter "hydrogen gas leakage detector") shall be installed at a position fitting for detection, such as the upper section of the area where the components (except one-piece piping) from the main stop valve to the fuel cell stack (the engine in a vehicle other than fuel cell vehicle) are installed. However, this provision shall not apply to the construction that comes under one of the following Items 3-9-1-1 or 3-9-1-2.

3-9-1-1 Construction in which the components (except one-piece piping) from the main stop valve to the fuel cell stack (the engine in a vehicle other than fuel cell vehicle) are installed in a space that is sufficiently open upward.

3-9-1-2 Construction in which hydrogen gas leaked from the components (except one-piece piping) from the main stop valve to the fuel cell stack (the engine in a vehicle other than fuel cell vehicle) will not stay, but will be led to the atmosphere by the method enumerated in the following items 3-9-1-2-1 through 3-9-1-2-3, and in which at least one hydrogen gas leakage detector is installed at an appropriate position of its passage.

3-9-1-2-1 It shall not be guided into the passenger compartment or luggage compartment;

3-9-1-2-2 It shall not be guided toward the tyre housing;

3-9-1-2-3 It shall not be guided toward exposed electrical terminals, electrical switches or other ignition sources.

3-9-2 A device shall be installed, that gives a warning to the driver that hydrogen gas is leaking when the hydrogen gas leakage detector detects hydrogen gas leakage.

3-9-3 A device shall be installed, that shuts off the supply of hydrogen gas when the hydrogen gas leakage detector detects hydrogen gas leakage.

3-9-4 The warning device shall be located at a position readily

recognizable by the driver.

3-9-5 When subjected to the tests according to Attached Table 3 “Test for Hydrogen Gas Leakage Detector, etc.,” the hydrogen gas leakage detector, device that gives a warning to the driver and device that shuts off the supply of hydrogen gas shall detect hydrogen gas, actuate the warning device, and shut off the supply of hydrogen gas. Moreover, if a motor vehicle is equipped with plural hydrogen systems, it shall be acceptable if the device shuts off the supply of hydrogen gas from the hydrogen system that is leaking hydrogen gas.

3-9-6 There shall be a device which gives a warning to the driver at the driver’s seat when an open wire or a short circuit takes place in the hydrogen gas leakage detector.

3-10 Pressure gauge and residual amount meter

3-10-1 The driver’s seat shall be provided with a pressure gauge indicating the pressure at the primary side of the first pressure-reducing valve, or a residual amount meter indicating the residual amount of hydrogen gas, calculated by adding the correction by the gas temperature to the pressure at the primary side of the first pressure-reducing valve.

Attached Sheet 1

AIRTIGHTNESS AND VENTILATION TEST

(Related to 3-5-2-1, 3-5-2-3 and 3-7-1 of this Technical Standard)

1. Airtightness test of housing

1-1 Test gas

The test gas shall be helium or carbon dioxide. (The same in Paragraph 2. below)

1-2 Test method

1-2-1 Insert a test gas induction hose, detector hose, and pressure gauge hose into the ventilation hole of the housing and completely seal the ventilation hole concerned.

1-2-2 Blow the test gas into the housing until the internal pressure of the container housing measures 10 kPa. Maintain this condition for 5 minutes.

1-2-3 Check gas leakage at each of the seal sections of the housing, using a gas detector.

2. Ventilation test of housing

2-1 Test method

After completion of the test of Paragraph 1.2, open all ventilation holes. Then, measure the change in test gas concentration in the housing at every 30 seconds. This measurement shall be continued for 20 minutes or until the gas concentration drops to 0%.

3. Airtightness test of piping, etc.

3-1 With the motor vehicle held stationary and the pressure applied to piping, etc., check to see if hydrogen gas leakage is present at confirmable sections of the piping, etc. from the high-pressure section to the fuel cell stack (the engine in vehicles other than fuel cell vehicles), using a gas detector or detector liquid, such as soap water.

Attached Sheet 2

**MEASUREMENT OF HYDROGEN CONCENTRATION OF
PURGED GAS AT TIME OF DISCHARGE**
(Related to 3-8-2 of this Technical Standard)

1. Measuring device

Devices for measuring hydrogen concentration ("measuring devices" in this Attached Sheet) shall be a contact-combustion type hydrogen detector having the capacity posted in the following table or any other detector of the equivalent capacity.

Table Capacity of contact-combustion type hydrogen detector

Item	Capacity
Range of detection	Hydrogen concentration 0 ~ 4%
Reading of hydrogen concentration	Reading should be possible at least to approximately 0.1 % of hydrogen concentration.
Indication error	±0.2% or below of hydrogen concentration
Measurement interval	100 millisecond (msec) or less

2. Measurement site

The measurement shall be conducted where it is little affected by wind.

3. Measurement method

3-1 Preparation for measurement

3-1-1 The fuel cell system of the test vehicle shall be warmed up thoroughly.

3-1-2 The measuring device shall be warmed up thoroughly before use.

3-1-3 Place the measuring section of the measuring device on the center line of the purged gas flow at the closest possible position within 100 mm from the purged gas discharge outlet.

3-1-4 If the fuel cell system stops automatically during the measurement, measures shall be taken so that the fuel cell system will not stop.

3-2 Measurement

Perform purging, following the procedure of 3-2-1 and 3-2-2 below. At this time, measure hydrogen concentration.

3-2-1 With the test motor vehicle in a stationary state, turn the ignition key switch to start the fuel cell system. Then, after a lapse of one minute or more, turn off the ignition key switch, and measure the hydrogen concentration during this period.

3-2-2 Continue the measurement of hydrogen concentration, until the purging is finished after the ignition key switch has been stopped.

4. Maximum hydrogen concentration

The maximum hydrogen concentration shall be the sum of the maximum value of the measured hydrogen concentration and the indication error of the measuring device.

Attached Sheet 3

TEST FOR HYDROGEN GAS LEAKAGE DETECTOR, ETC.

(Related to 3-9-5 of this Technical Standard)

1. Test conditions

1-1 Test vehicle

The test vehicle shall be in the condition given in Paragraphs 1-1-1 and 1-1-2 below.

1-1-1 Unless necessary for the discharge of test gas, the hood, luggage compartment lid, and doors shall be closed.

1-1-2 Components that are unlikely to affect test results need not be genuine parts.

1-2 Test gas

Mixture of air and hydrogen gas with $3.9\% \pm 0.1\%$ hydrogen concentration shall be used.

1-3 Test site

The test shall be conducted where it is little affected by wind.

2. Test method

2-1 Preparation for test

2-1-1 Start the fuel cell system of the test vehicle if the vehicle is a fuel cell vehicle, and warm it up thoroughly in a stationary state. If the vehicle is not a fuel cell vehicle, warm it up and keep it idling.

2-1-2 If necessary for blowing the test gas to the hydrogen gas leakage detector without fail, the following measures of Paragraphs 2-1-2-1 through 2-1-2-3 may be taken.

2-1-2-1 Attach a test gas induction hose to the hydrogen gas leakage detector.

2-1-2-2 Take measures to make the gas stay near the hydrogen gas leakage detector.

2-1-2-3 Remove the hydrogen gas leakage detector.

2-1-3 If the fuel cell system in a fuel cell vehicle stops automatically during the test, measures shall be taken so that the fuel cell system will not stop. If the test vehicle is not a fuel cell vehicle and is constructed to stop idling automatically, measures shall be taken so as to prevent the engine from stopping.

2-1-4 In cases where the operating conditions of the device to shut off hydrogen gas supply cannot be confirmed, confirmation may be performed by monitoring the operating signal or supply power of the shut-off valve.

2-2 Test

Blow test gas to the hydrogen gas leakage detector.

(Reference)

INSTALLATION OF HYDROGEN GAS LEAKAGE DETECTOR IN FUEL CELL VEHICLES

(Related to 3-9-1 of this Technical Standard)

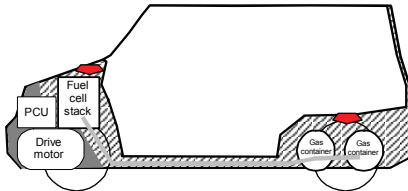
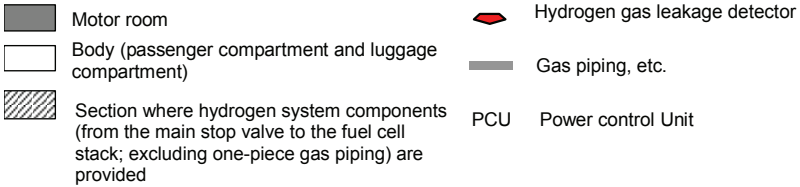

Example 1. Hydrogen system components installed in the motor room and under the floor of the body

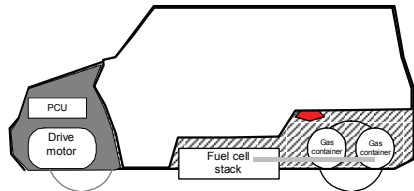

Example 2. Hydrogen system components installed under the floor of the body, separate from the motor room

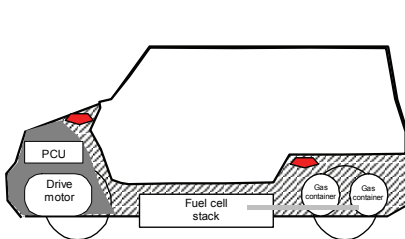

Example 3. Hydrogen system components installed under the floor of the body (two upward sections)

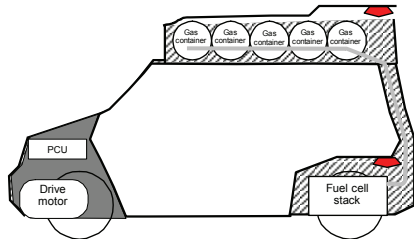

Example 4. Hydrogen system components installed at the roof and under the floor of the body

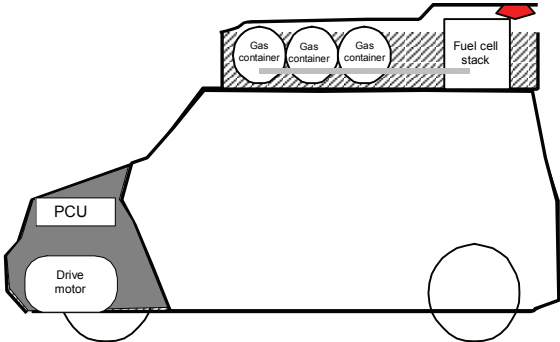

Example 5. Hydrogen system components installed at the roof

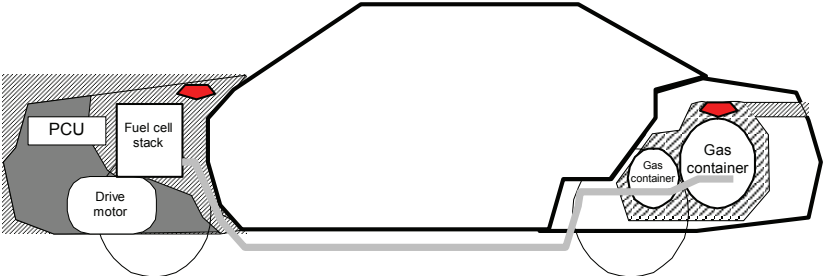

Example 6. Hydrogen system components installed in the motor room and in the housing in the luggage compartment

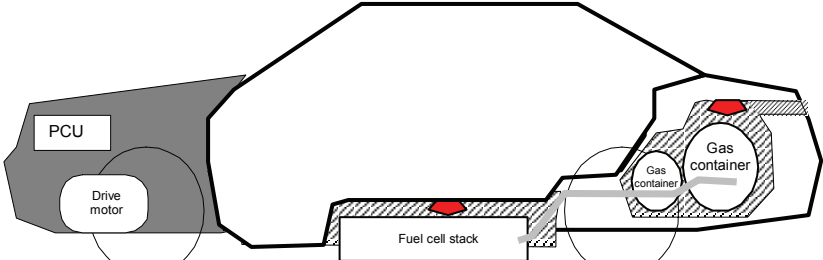

Example 7. Hydrogen system components installed under the floor of the body and in the housing in the luggage compartment

Attachment 101**TECHNICAL STANDARD FOR PROTECTION OF OCCUPANTS
AGAINST HIGH VOLTAGE IN FUEL CELL VEHICLES**

1. Scope

This technical standard shall stipulate the technical regulations in connection with protection against electrical shock for fuel cell vehicles (except motorcycles with or without sidecar) and shall apply to the entire power train (including the alternating current section) having a section where the operating voltage is DC 60V or greater.

However, this technical standard shall not apply to the section whose operating voltage is less than DC 60V, which is thoroughly insulated from the section whose operating voltage is DC 60V or greater and whose pole at one side, either positive or negative, is connected to the electrical chassis in electrical DC.

2. Definitions

In addition to the definitions described in Article 1 of the Safety Regulations, the terms appearing in this Technical Standard shall be defined in Paragraphs 2-1 through 2-15 given below:

2-1 The power train is an electric circuit containing the following items in Paragraphs 2-1-1 through 2-1-5.

2-1-1 Fuel cell stack

2-1-2 Drive battery

2-1-3 Electronic converter (referring to a device capable of controlling or converting power, such as electronic controller for drive motor and DC/DC converter)

2-1-4 Drive motor and associated wire harness, connector, etc.

2-1-5 Auxiliary devices related to running (e.g., heater, defroster, power steering, etc.)

2-2 The fuel cell stack is a device that directly generates electricity by causing hydrogen to react with oxygen.

2-3 The drive battery is an electrical power storage unit and its aggregate that are connected electrically for the purpose of supplying electric power related to the driving.

2-4 Direct contact refers to contact between the human body and energized components.

2-5 Energized components are conductive components whose purpose is to transmit electric current during normal applications.

2-6 Indirect contact refers to contact between the human body and exposed electroconductive components.

2-7 Exposed electroconductive components are conductive components (except conductive components, such as cooling devices in Paragraph 3-4) that do not normally conduct electricity, but may do so at the time of insulation failure, and that can be contacted easily without using tools. In this case, whether or not a component can be contacted easily shall be judged, in principle, by the confirmation method as to whether the construction of protection class IPXXB is provided or not.

2-8 Electrical circuit refers to an aggregate of connected energized components designed to facilitate the flow of electric current during normal operation.

2-9 Nominal voltage is the design voltage indicating the characteristics of an electrical circuit, specified by the vehicle manufacturer concerned.

2-10 Operating voltage is the maximum potential difference, specified by the vehicle manufacturer concerned, that might possibly arise between all conductive elements during normal operation or when the circuit is released.

2-11 Electrical chassis is an aggregate of electroconductive components that have been electrically connected to each other, whose potential is regarded as the standard.

2-12 The barrier refers to components placed so as to protect from energized components against direct contact from all conceivable directions of approach.

2-13 The enclosure is the component established to enclose internal units and protect against direct contact from all directions.

2-14 The service plug is a device for shutting off the electric circuit when

conducting checks and services of the fuel cell stack, drive battery, etc.

2-15 Protection class IPXXB and protection class IPXXD refer to those defined in Attached Sheet 1 “Protection Against Direct Contact with Energized Components.”

3. Requirements for Protection from Electrical Shock

3-1 Protection against direct contact

3-1-1 The protection against direct contact with energized components shall comply with Paragraphs 3-1-1-1 and 3-1-1-2 by such things as a solid insulator, barrier or enclosure, etc. These protective elements must be attached securely and be sturdy. Furthermore, it must not be possible to open, disassemble or remove these elements without tools.

3-1-1-1 For protection against energized components in the passenger compartment or cargo compartment, in all cases protection class IPXXD must be satisfied at the very least. However, in the case of the service plug that can be opened, disassembled and removed without tools, it is acceptable if protection class IPXXB is satisfied under a condition where it is opened, disassembled or removed without tools.

3-1-1-2 For protection against energized components other than those in the passenger compartment and cargo compartment, the protection class IPXXB must be satisfied.

3-1-2 Vehicle Marking

Barriers and enclosures installed for protection against direct contact shall be marked in the manner of the example given in Attached Sheet 2 “Warning Sign for Protection Against Electrical Shock.”

However, this provision shall not apply to barriers and enclosures which are not accessible, unless the parts are removed by means of tools or the motor vehicle is lifted by means of a jack.

3-2 Protection Against Indirect Contact

3-2-1 For protection against electrical shock which could arise from indirect contact, the exposed electroconductive components, such as the electroconductive barrier and enclosure must be connected securely to the electrical chassis in electrical DC so that no dangerous potentials are produced. This shall be accomplished either by connection with electrical

wire or ground cable, or by welding, or by connection using bolts, etc.

3-2-2 The resistance between the electrical chassis and all exposed electroconductive components shall be less than 0.1 ohm. This resistance shall be measured when there is current flow of at least 0.2 amperes. Such measurement is not required, however, when it is clearly evident that the DC electrical connection has been established adequately and securely by such means as welding.

3-3 Insulation Resistance

Insulation resistance (except the insulation resistance between the energized components and the electrical chassis of motor vehicles for which measures have been taken according to Paragraph 3-4-2, which will drop due to only the deterioration, etc. of the fuel cell stack refrigerant) between the energized components (except electroconductive sections that come in direct contact with the refrigerant to which Paragraph 3-4 applies) and the electrical chassis shall be 100 ohms or more per volt of nominal voltage when the measurement is conducted according to Attached Sheet 3 “Insulation Resistance Measurement Method” or a method equivalent to it. In this case, in vehicles where the insulation resistance between the energized components and the electrical chassis is monitored, if the vehicle is equipped with a device to warn the driver before insulation resistance has fallen to 100 ohms per volt of nominal voltage, and if it is confirmed that the said mechanism is in operation and the warning is not in operation, measurement is not required.

3-4 Protection Against Electrical Shock Due to Fuel Cell Stack Refrigerant

To prevent electrical shock due to the drop in insulation resistance caused by the deterioration, etc. of the fuel cell stack refrigerant, any one of the following measures prescribed in Paragraphs 3-4-1 through 3-4-3 must be taken for the electroconductive sections of the cooling device that come in direct contact with the refrigerant. In this case, the measures prescribed in Paragraphs 3-4-1 through 3-4-3 may be different, depending on the electroconductive materials that come in direct contact with the refrigerant.

3-4-1 Protection Against Contact with Electroconductive Materials That Are in Direct Contact with the Refrigerant

The measures complying with Paragraphs 3-1 and 3-3 in connection with energized components shall be taken for electroconductive materials coming in direct contact with the refrigerant. In this case, if the electroconductive barrier or enclosure is used, the measures complying with Paragraph 3-2 in connection with exposed electroconductive materials also

shall be taken.

3-4-2 Monitor of Drops in Insulation Resistance

The requirements of Paragraphs 3-4-2-1 through 3-4-2-3 below shall be satisfied.

3-4-2-1 There must be a device to monitor the insulation resistance between the electric circuit of the fuel cell stack and the electrical chassis and to warn the driver before the insulation resistance drops to 100 ohms per volt of nominal voltage. Its function shall be confirmed by the method prescribed in Attached Sheet 4 “Confirmation Method for Functions of Monitor of Drops in Insulation Resistance” or a method equivalent to it.

3-4-2-2 The device to warn the driver shall be such one that it can be confirmed that its function is in operation at the driver’s seat under a condition where the vehicle is in stationary state.

3-4-2-3 With regard to electroconductive materials that come in direct contact with the refrigerant, that can be easily contacted without using tools, measures complying with Paragraph 3-2 in connection with exposed electroconductive materials shall be taken.

3-4-3 Power Supply Cutoff Upon Electrical Leakage

Whenever there is a leakage of electrical current, there must be a mechanism to cutoff the power supply immediately before the current can reach a level dangerous to the human body. Moreover, it is satisfactory if the shutoff part is provided in such a way that only the energizing of refrigerant and electroconductive materials that are in direct contact with the refrigerant may be shut off.

Requirements of power supply shutoff at the time of the electric leakage and the confirmation method of function are prescribed in Attached Sheet 5 “Function Confirmation Method of Power Supply Shut-off at Time of Electric Leakage.” In this case, the confirmation may be conducted by a method equivalent to the method prescribed in the said Attached Sheet.

Attached Sheet 1**PROTECTION AGAINST DIRECT CONTACT WITH
ENERGIZED COMPONENTS**

1. General Provisions

Protection class IPXXB and protection class IPXXD against direct contact with energized components shall be prescribed in this Attached Sheet. Furthermore, this Attached Sheet shall apply to the power train whose operating voltage does not exceed AC 1000V and DC 1500V.

Moreover, in this Attached Sheet, the energized sections provided for in Paragraph 2-5 of the main text as well as the sections described in Paragraphs 1-1 and 1-2 below shall be regarded as the “energized component” when the evaluation is conducted.

1-1 Energized components that are protected only by varnish or paint;

However, this provision shall not apply to those where varnish or paint has been used for the purpose of insulation.

1-2 Energized components that are protected through oxidation treatment or similar treatment.

2. Test Conditions

The test vehicle shall be in a state where the starting device is stopped.

2-1 Proximity probe, etc.

2-1-1 As regards the proximity probe to be used for the confirmation of protection class, those prescribed according to the protection class shown in Table 1 shall be used.

2-1-2 In checking for the presence/absence of contact between proximity probe and energized components inside the barrier, enclosure, etc., using the signal display circuit method, a low-voltage power supply (40V or more, but not exceeding 50V) is connected in series to a suitable lamp and between the proximity probe and the energized components.

2-1-3 In the case of the signal display circuit method, sections provided for in Items 1-1 and 1-2 above shall be covered with electroconductive metal

foil and the said metal foil shall be connected electrically to regular energized components.

3. Test Methods

3-1 Using the force prescribed in the “Test force” column of Table 1, the proximity probe is pressed against the opening (referring to a gap or opening of the barrier, enclosure, etc. that already exists or can appear whenever the proximity probe is applied at the prescribed force) of the barrier, enclosure, etc.

3-1-2 If it is possible, the moveable parts in the enclosure are operated slowly.

3-1-3 When the proximity probe is inserted in whole or in part, it is applied to all sections where there is the possibility of contact. Then, confirmation shall be made as to whether or not there is contact (In the case of the signal display circuit method, the illumination condition of the lamp shall be confirmed (hereinafter the same in this Attached Sheet)). In this case, in conducting a test covering protection class IPXXB, the test shall be started with the articulated test needles in a straight line. Both joints must be bent sequentially until they are 90° against the axis of the node where the articulated test needles adjoin each other. Then, confirmation shall be made as to whether or not there is contact with all components where there is the possibility of contact.

4. Assessment Criteria

4-1 The proximity probe must not contact the energized component.

4-2 Moreover, in all cases, the end surface of the proximity probe, in passing through the opening, must not be fully inserted.

4-3 In conducting the confirmation, using the signal display circuit method, the lamp must not glow.

Table 1 Proximity Probe

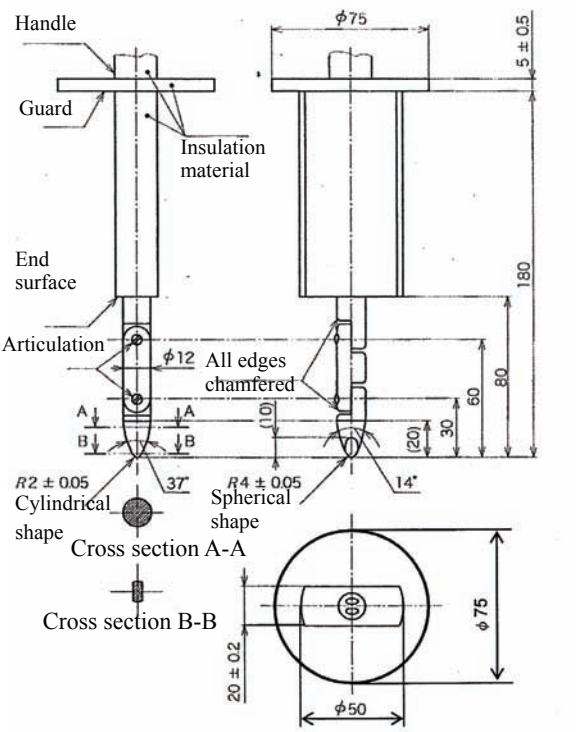
	Proximity probe	Test force
<p>Test covering protection class IPXXB</p>	 <p>Materials: Metals, except for items stipulated in the figure</p> <p>Linear dimension unit: mm</p> <p>Tolerance of dimensions not stipulated in the figure Angle: +0 min. / -10 min.</p> <p>Linear dimension 25mm or less: +0 mm / -0.05 mm over 25mm: +/-0.2 mm</p> <p>It shall be possible to move both joints within the same surface, in the same direction, up to 90 degrees within a tolerance of -0 degrees to +10 degrees.</p>	<p>10N±10%</p>

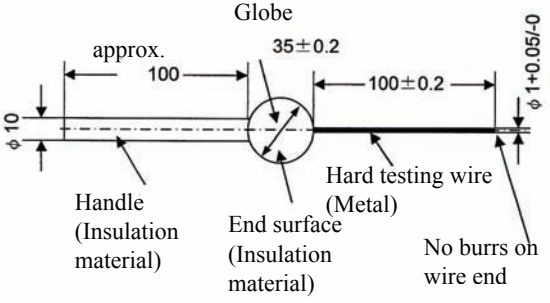
<p>Test covering protection class IPXXD</p>	<p>Testing wire; Diameter 1.0mm; Length 100mm</p>  <p>Unit of dimension of straight line: mm</p>	<p>1N±10%</p>
---	---	---------------

Attached Sheet 2**WARNING SIGN FOR PROTECTION
AGAINST ELECTRICAL SHOCK**

Fig. 1 shall show examples of marking on the barrier and enclosure to be installed for protection against direct contact.



Black on
yellow or
amber
ground

Fig. 1 Example of Warning Sign

Attached Sheet 3

INSULATION RESISTANCE MEASUREMENT METHOD

The following shall prescribe the measurement of insulation resistance.

1. Handling of Measurement

The measurement of the insulation resistance shall be conducted by the methods of 1-1 or 1-2 below:

1-1 The insulation resistance may be measured for the whole vehicle;

1-2 The measurement may be performed by dividing according to each part or component unit (hereinafter referred to as the “divided measurement”). Then, the insulation resistance of the entire vehicle may be determined through calculation.

2. Measurement Method

As measurement method, Paragraph 2-1 shows the measurement method in which a DC voltage is applied from the outside, whereas Paragraph 2-2 shows the measurement method in which the inner DC voltage power supply source is used.

Moreover, this confirmation requires the operation of the high-voltage circuit directly. Therefore, utmost care must be exercised as to short circuit, electric shock, etc.

2-1 Example of measurement method in which DC voltage is applied from outside

2-1-1 Test vehicle conditions

The measurement shall be conducted, in principle, under a condition where the drive battery is disconnected and the fuel cell is in a stopped state.

2-1-2 Measurement instrument

An insulation resistance test instrument capable of applying a DC voltage higher than the operating voltage of the electrical circuit of the power train shall be used.

2-1-3 Measurement method

2-1-3-1 After confirming that no high voltage is applied, an insulator resistance test instrument shall be connected between the energized component and the electrical chassis. Then, the insulation resistance shall be measured by applying a DC voltage higher than the operating voltage of the power train. However, in the case of the measurement of insulation resistance of the electroconductive materials that are in direct contact with the refrigerant, if there are parts whose withstand voltage is low and there is the possibility that the parts become damaged during the measurement, it shall be permissible to perform the measurement below the operating voltage within a range not below the maximum voltage that can apply to the electroconductive materials concerned.

2-1-3-2 The measurement shall be conducted for all energized components. Then, the smallest value shall be regarded as the insulation resistance. However, with regard to energized components connected with the low DC resistance, which is clear from the circuit diagram, etc., it shall be acceptable if the measurement is conducted at least once at any of these points.

2-1-3-3 Moreover, in the case of the divided measurement, the resultant resistance shall be determined through calculation, taking into consideration the DC resistance existing intrinsically between the divided sections. This calculated value shall be regarded as an insulation resistance.

2-2 Example of measurement method in which inner DC voltage source is used

2-2-1 Test vehicle conditions

The drive battery shall be charged to such an extent that it functions normally.

2-2-2 Measurement instrument

The voltmeter to be used for the measurement shall be, in principle, a DC voltmeter whose inner resistance is 10 M ohms or greater.

In cases where a DC voltmeter whose inner resistance is less than 10 M ohms is used, it is permissible to insert an appropriate resistor in series so that the resultant series resistance becomes 10 M ohms or greater. In this case, however, the resistor to be inserted in series shall be such one that will unlikely be affected by temperature. Furthermore, the same voltmeter and same resistor shall be used for all voltage measurements.

2-2-3 Measurement method

2-2-3-1 First step

As shown in Fig. 1, measure the voltage V_1 between the negative terminal of the drive battery and the electrical chassis and V_1' between the positive terminal of the drive battery and the electrical chassis.

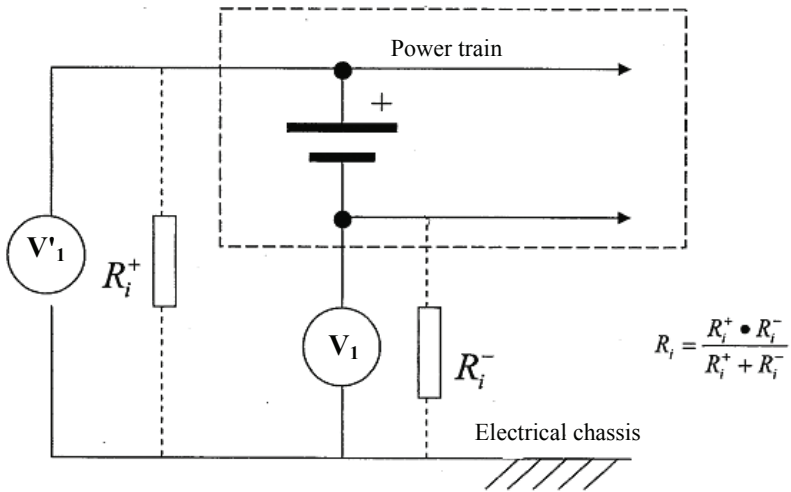

Fig. 1 Voltage measurement of first step

2-2-3-2 Second step

In cases where the voltage measurement of the first step results in $V_1 > V_1'$, as shown in Fig. 2, the resistor R_0 having 100 ohms per nominal voltage shall be connected between the negative terminal of the drive battery and the electrical chassis. Then, the voltage V_2 shall be measured between the negative terminal of the drive battery and the electrical chassis. In this case, the insulation resistance R_i shall be determined, using the following formula.

$$R_i = \frac{V_1 - V_2}{V_2} \times R_0$$

Furthermore, in cases where the voltage measurement of the first step results in $V_1 < V'_1$, as shown in Fig. 3, the resistor R_0 having 100 ohms per nominal voltage shall be connected between the positive terminal of the drive battery and the electrical chassis. Then, the voltage V_2 shall be measured between the positive terminal of the drive battery and the electrical chassis. In this case, the insulation resistance R_i shall be determined, using the following formula.

$$R_i = \frac{V'_1 - V_2}{V_2} \times R_0$$

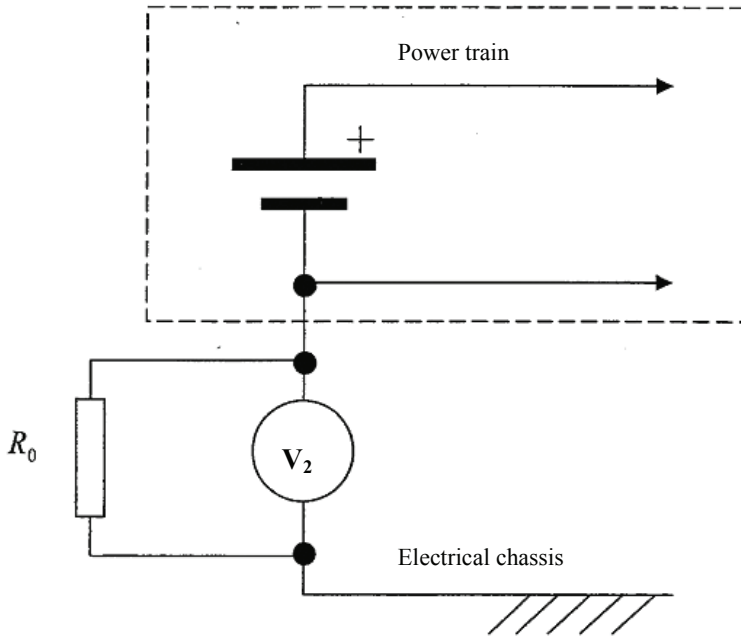

Fig. 2 Voltage measurement of second step (case of $V_1 > V'_1$)

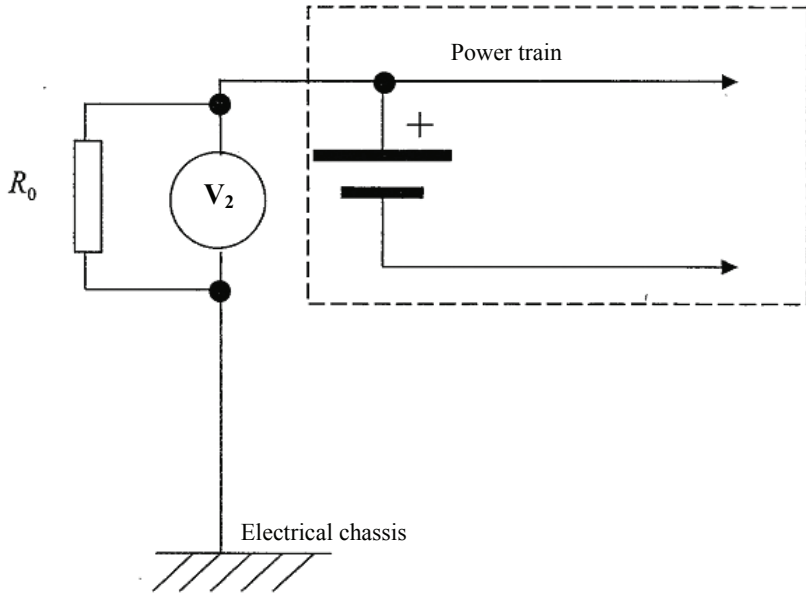

Fig. 3 Voltage measurement of second step (case of $V_1 < V_1'$)

Attached Sheet 4**CONFIRMATION METHOD FOR FUNCTIONS OF MONITOR OF DROPS IN INSULATION RESISTANCE**

As an example of the confirmation method for functions of monitor of drops in insulation resistance, Paragraph 1 shows an example of the confirmation method in which a resistor is inserted in parallel. Paragraph 2 gives an example of the confirmation method in which pseudo signal is added.

Moreover, this confirmation requires the operation of the high-voltage circuit directly. Therefore, utmost care must be exercised as to short circuit, electrical shock, etc.

1. Example of confirmation method in which a resistor is inserted in parallel in the high-voltage circuit

In principle, this test confirms that, when such a resistor that makes the combined resistance with the measured insulation resistance 100 ohms per nominal voltage when connected in parallel thereto is inserted between the monitoring terminal and the electrical chassis, the driver is warned in an easily understandable way.

However, in cases where the combined resistance cannot be set to 100 ohms per nominal voltage due to the resistance of a resistor to be inserted in parallel, the setting shall be made to the smallest possible resultant resistance of 100 ohms or greater per nominal voltage.

2. Example of confirmation method in which pseudo signal is inputted

In cases where the relationship between the input value and output voltage of the sensor is clear through the data of characteristics of the sensor being used, etc., this test confirms that, when a pseudo voltage corresponding to the output voltage equivalent to 100 ohms per nominal voltage is applied instead of the output of the sensor concerned, the driver is warned in an easily understandable way.

Attached Sheet 5**FUNCTION CONFIRMATION METHOD OF POWER SUPPLY
SHUT-OFF AT TIME OF ELECTRIC LEAKAGE**

The following shall prescribe the function confirmation method and requirements of power supply shut-off at time of electric leakage.

1. Confirmation method for functions of power supply shut-off at time of electric leakage

As an example of the confirmation method for functions of power supply shut-off at time of electric leakage, Paragraph 1.1. shows an example of the confirmation method in which leakage of electric current is caused by the resistor. Paragraph 1-2 gives an example of the confirmation method in which pseudo signal is added.

Moreover, this confirmation requires the operation of the high-voltage circuit directly. Therefore, utmost care must be exercised as to short circuit, electrical shock, etc.

1-1 Example of confirmation method in which leakage of electric current is caused by resistor

An appropriate resistor shall be inserted between the terminal for which the leaking electric current is monitored and the electrical chassis. At this time, the relationship between the electric current flowing in the resistor and the time elapsed until the shutting-off, shall be measured. The measurement shall be conducted with various electric currents by changing the resistance of the resistor connected.

1-2 Example of confirmation method in which pseudo signal is inputted

In cases where the relationship between the input value and output voltage of the sensor is clear through the submitted data of characteristics of the sensor being used, etc., the relationship between the pseudo voltage being applied and the time elapsed until the shutting-off shall be measured when a pseudo voltage corresponding to the output voltage equivalent to the shutting-off limitation indicated in Fig. 1 is applied instead of the output of the sensor concerned.

2. Requirements of power supply shut-off at time of electric leakage

The shut-off requirements shall be prescribed according to the leaking electric current and continuation time. Shutting-off shall take place below 200 mA when the continuation time is 10 msec or less; below the electric current determined from the following formula according to the continuation time when the continuation time is between 10 msec and 2 seconds; and below 26 mA when the continuation time is 2 seconds or more. (see Fig. 1.)

$$I = 10^{-0.38507 \log_{10} t + 2.6861}$$

where:

I : Leaking electric current (mA)

t : Continuation time (msec)

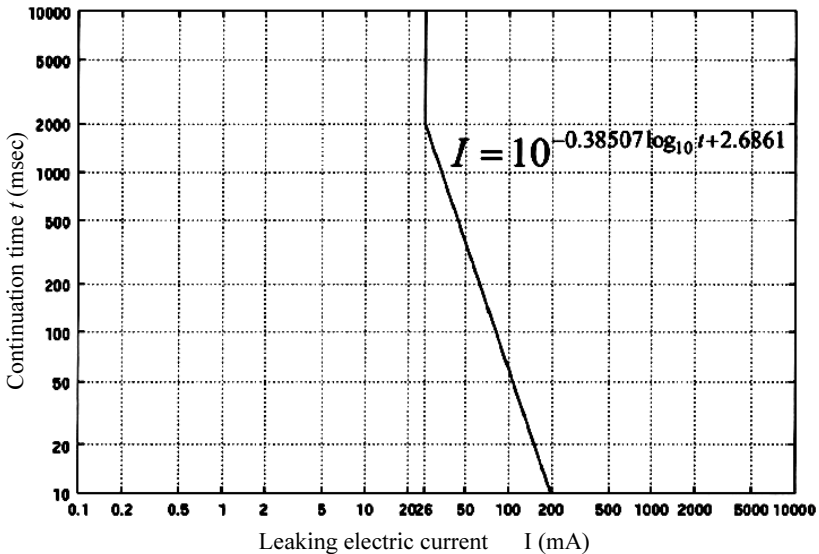

Fig. 1 Requirements of Power Supply Shut-off at Time of Electric Leakage