

Transmitted by the expert from Sweden

Informal document No. GRSP-41-11
(41st GRSP, 7-11 May 2007,
agenda item 10.1.)

Proposal for draft amendments to Regulation No. 29

Regulation No. 29

Note; This is a proposal for an updated lay-out of the Regulation. It also include proposal to amend the Regulation. The proposal has to be completed with test procedures/methods.

**UNIFORM PROVISIONS CONCERNING THE APPROVAL OF VEHICLES WITH
REGARD TO THE PROTECTION OF OCCUPANTS OF THE CAB OF A
~~COMMERCIAL~~ VEHICLE**

Regulation No. 29

UNIFORM PROVISIONS CONCERNING THE APPROVAL OF VEHICLES WITH REGARD
TO THE PROTECTION OF THE OCCUPANTS OF A ~~COMMERCIAL~~ VEHICLE

CONTENTS

REGULATION	<u>Page</u>
1. Scope	
2. Definitions	
3. Application for approval.....	
4. Approval	
5. Requirements	
6. Modification and extension of approval of the vehicle type	
7. Conformity of production.....	
8. Penalties for non-conformity of production	
9. Production definitely discontinued.....	
10. Transitional provisions	
11. Names and addresses of technical services responsible for conducting approval tests, and of administrative departments	

ANNEXES

- ~~Annex 1 — Communication concerning the approval or extension or refusal or withdrawal of approval or production definitely discontinued of a vehicle type with regard to the protection of the occupants of the cab of a commercial vehicle, pursuant to Regulation No. 29~~
- Annex 1 - ECE Type-approval documentation**
Part I – Model Information document
Part II – Type-approval certificate
- Annex 2 - Arrangements of the approval mark.

Annex 3 - **Test set-up**

Appendix 1: Instruction for securing vehicle to the test bed.

Annex 4 - **Test procedure for test A –Frontal impact**

Annex 5 - **Test procedure for test B - 90° rollover (Impact on the A-pillar)**

Annex 6 - **Test procedure for test C - 180° rollover**

Annex 7 - **Procedure for determining the “H” point and the actual torso angle for seating position in motor vehicle.**

Appendix 1: Description of the three-dimension “H” point machine

Appendix 2: Three-dimension reference system

Annex 8 - **Reference data concerning seating position**

* * *

1. SCOPE

This Regulation applies to vehicles **with separate driver's cab** of category N¹/ with regard to the protection of the occupants of the cab.

2. DEFINITIONS

For the purposes of this Regulation:

- 2.1. "Approval of a vehicle" means the approval of a vehicle type with pursuant to the requirements of this Regulation, with regard to the protection of the occupants of the cab of a ~~commercial~~ vehicle in the event of head-on impact or of overturning, ~~or of shifting of the load;~~
- 2.2. "Vehicle type" means a category of ~~power-driven~~ **motor** vehicle which does not differ in such essential respects as:
- 2.2.1. the dimension, shapes and materials of the components of the vehicle cab; ~~or~~
- 2.2.2. the manner of attachment of the cab to the chassis frame;
- 2.2.3. **the vehicle category;**
- 2.2.4. **the technical permissible maximum mass for the front axle or axles of the vehicle;**
- 2.3. "transverse plane" means a vertical plane perpendicular to the longitudinal plane of the vehicle;
- 2.4. "longitudinal plane" means a plane parallel to the median longitudinal plane of **the vehicle;**
- 2.5. "Cab-over engine truck" means a truck where [more than the half length of the engine] is located behind the forward part of the bottom edge of the windshield.
- 2.6. "Cab" means a system of integrated structural elements or other structural element which form part of the outer geometry of the cab, the primarily aim of which is to protect the driver and passenger in case of frontal-impact or overturning.
- 2.7. "Cab attachment components" means structural elements, sprung or unsprung including vibration dampers, with appurtenances connection with

1/ As defined in Annex 7 to the Consolidated Resolution on the Construction of Vehicles (R.E.3), (document TRANS/WP.29/78/Rev.1/Amend.2 as last amended by Amend.4).

which the cab is attached to the frame or chassis.

- 2.8 **“Cab lock”** means locking device which prevent a tilting cab from tilting accidentally.
- 2.9 **“Side doors”** means devices with which the standard opening to the driver and passenger position is closed.
- 2.10 **“Door locks”** means device which primarily ensures that the side door of the cab normally remains closed.
- 2.11 **“Door hinge”** means a device with which side door(s) is/are hinged.
- 2.12 **“Steering control”** means the aggregate comprising the steering wheel, the steering column, the assembly accessories, the steering shaft, the steering gear housing, and all other components such as those designed to contribute to the absorption of energy in the event of impact against the steering control.
- 2.13 **“R point”** means a reference point defined for each seat by the manufacture in relation to the vehicle’s structure, as indicated in annex 8.
- 2.14 **“H-point”** means the reference point determined for each seat by the technical service responsibly for the testing, in accordance with the procedure described in annex 8.
- 2.15 **“Survival space”** means the volume space required to survive determined by the manikin defined in paragraph 5.2.
- 2.16 **“Test A”** means a frontal impact strength test intended to evaluate the resistance of a cab in frontal impact accident.
- 2.17 **“Test B”** means an angled impact test by a pendulum to one of the A-pillars of the cab intended to evaluate the resistance of a cab in a 90° rollover accident with subsequent impact.
- 2.18 **“Test C”** means an cab roof strength test intended to evaluate the resistance of a cab in a 180° rollover accident.

3. APPLICATION FOR APPROVAL

- 3.1. The application for approval of a vehicle type with regard to the protection of the occupants of the cab of a ~~commercial~~ vehicle shall be submitted by the vehicle manufacturer or by his duly accredited representative.
- 3.2 It shall be accompanied by drawings of the vehicle, showing the position of the cab on the vehicle and the manner of its attachment, and by sufficiently detailed drawings relating to the structure of the cab, all the said drawings being submitted

in triplicate. **A model for the information document relating to the constructional features is given in annex 1 Part 1.**

3.3 A vehicle(s) representative of the type to be approved shall be submitted to the technical service responsible for conducting the type-approval tests.

4. APPROVAL

4.1. If the vehicle type submitted for approval pursuant to this Regulation meets the requirements of paragraph [5] hereof, approval of that vehicle type shall be granted.

4.2. An approval number shall be assigned to each type approved. Its first two digits (at present ~~02-03~~ corresponding to the ~~02 03~~ series of amendments) shall indicate the series of amendments incorporating the most recent major technical amendments made to the Regulation at the time of issue of the approval. The same Contracting Party may not assign the same number to another vehicle type within the meaning of paragraph 2.2 above.

4.3. Notice of approval or of extension or of refusal or of withdrawal of approval or production definitely discontinued of a vehicle type pursuant to this Regulation shall be communicated by the Parties to the Agreement which apply this Regulation by means of a form conforming to the model in annex 1 to this Regulation.

4.4. There shall be affixed, conspicuously and in a readily accessible place specified on the approval form, to every vehicle conforming to a vehicle type approved under this Regulation, an international approval mark consisting of:

4.4.1. a circle surrounding the letter "E" followed by the distinguishing number of the country which has granted approval, 1/ and

1/ 1 for Germany, 2 for France, 3 for Italy, 4 for the Netherlands, 5 for Sweden, 6 for Belgium, 7 for Hungary, 8 for the Czech Republic, 9 for Spain, 10 for Yugoslavia, 11 for the United Kingdom, 12 for Austria, 13 for Luxembourg, 14 for Switzerland, 15 (vacant), 16 for Norway, 17 for Finland, 18 for Denmark, 19 for Romania, 20 for Poland, 21 for Portugal, 22 for the Russian Federation, 23 for Greece, 24 for Ireland, 25 for Croatia, 26 for Slovenia, 27 for Slovakia, 28 for Belarus, 29 for Estonia, 30 (vacant), 31 for Bosnia and Herzegovina, 32 for Latvia, 33 (vacant), 34 for Bulgaria, 35-36 (vacant), 37 for Turkey, 38-39 (vacant), 40 for The former Yugoslav Republic of Macedonia, 41 (vacant), 42 for the European Community (Approvals are granted by its Member States using their respective ECE symbol), 43 for Japan, 44 (vacant), 45 for Australia and 46 for Ukraine. Subsequent numbers shall be assigned to other countries in the chronological order in which they ratify or accede to the Agreement Concerning the Adoption of Uniform Technical Prescriptions for Wheeled Vehicles, Equipment and Parts which can be Fitted and/or be Used on Wheeled Vehicles and the Conditions for Reciprocal Recognition of Approvals Granted on the Basis of these Prescriptions, and the numbers thus assigned shall be communicated by the

2007-04-30 6 (37)

- 4.4.2. the number of this Regulation, followed by the letter "R", a dash and the approval number, to the right of the circle prescribed in paragraph 4.4.1.; and
- ~~4.4.3. an additional symbol separated from the number of this Regulation by a vertical line and consisting of the letter "C" if the cab meets the requirements of test C.~~
- 4.5. If the vehicle conforms to a vehicle type approved, under one or more other Regulations annexed to the Agreement, in the country which has granted approval under this Regulation, the symbol prescribed in paragraph 4.4.1. need not be repeated; in such a case the additional numbers and symbols of all the Regulations under which approval has been granted in the country which has granted approval under this Regulation shall be placed in vertical columns to the right of the symbol prescribed in paragraph 4.4.1.
- 4.6. The approval mark shall be clearly legible and be indelible.
- 4.7. The approval mark shall be placed close to or on the vehicle data plate.
- 4.8. Annex 2 to this Regulation gives examples of arrangements of approval marks.

5. REQUIREMENTS

5.1. **General requirements applicably to all cabs**

- 5.1.1. **The "H" point for each seat shall be determined in accordance with the procedure described in annex 8.**
- 5.1.2. The cab of the vehicle shall be so designed and so attached to the vehicle as to eliminate to the greatest possible extent the risk of injury to the occupants in the event of an accident.
- 5.1.3. **One, two or three cabs, at the manufacturer's choice, shall may be used for the purpose of demonstrating compliance with paragraph 5.1.1 above, on the basis of the requirements of paragraph [5.x or 5.x] below. However the both phases in test C shall be conducted on the same cab.**
- 5.1.4. Tests B and C need not be carried out if the manufacturer can show by **computer simulation that the cab** ~~calculations of the strength of the component parts of the cab or by other means that the roof or rear wall~~ will not undergo deformation dangerous to the occupants (penetration into the survival space) if subjected to the conditions of tests B and C.
- 5.1.5. **Cab locks if any shall have a fully latched and an intermediate latched position. Furthermore the intermediate position shall operate automatically.**

Secretary-General of the United Nations to the Contracting Parties to the Agreement.

- 5.1.6. Door locks shall be designed in such a way as to prevent the doors opening accidentally. Each lock shall have a fully latched and an intermediate latched position.
- 5.1.7. During the tests the components by which the cab is secured to the chassis frame may be distorted or broken, provided that the cab remains attached to the chassis frame.
- 5.1.8. None of the doors shall open during the tests, but the doors shall not be required to open after testing.

5.2. **Survival space required after the test or tests**

- 5.2.1. After undergoing each of the tests referred to in paragraph [5] the cab of the vehicle shall exhibit a survival space allowing accommodation of an un-instrumented 95th [50th] percentile Hybrid II or III male dummy 2/ on the seats without contact between the manikin and non-resilient parts. The seats, the steering wheel and the dummy shall be adjusted according to paragraphs 5, 6 and 7 in annex 3.

For demonstrating the survival space according to the above for cabs on vehicle of category N₁ and N₂ with a gross vehicle weigh not exceeding 7.5 ton an un-instrumented 50th percentile Hybrid II or III male dummy may be used.

- 5.2.2. The survival space shall be verified for every seat provided by the manufacturer.

5.3. **Test applicably for cabs on vehicle of category N₁ and N₂ with a gross vehicle not exceeding 7.5 ton**

- 5.3.1. xxxxxx
This section has to be completed after discussion in the ad-hoc group.

5.4. **Test applicably for cabs on vehicle of category N₂ with a gross vehicle weigh exceeding 7.5 ton and N₃**

- 5.4.1. xxxxxxxxxx

2 / The technical specifications and detailed drawing of Hybrid III, corresponding to the principal dimensions of a fiftieth percentile male of the United States of America, and the specifications for its adjustment for test are deposited with the Secretary-General of the United Nations and may be consulted on request at the secretariat of the Economic Commission for Europe, Palais des Nations, Geneva, Switzerland.

This section has to be completed after discussion in the ad-hoc group

~~5.2. [It shall be subjected, at the manufacturer's choice, either to all the tests specified in annex 3 to this Regulation or only to tests A and B. However a vehicle type which has been approved according to Regulation No. 33 may be considered to have satisfied the requirements on frontal impact (test A). One, two or three cabs, at the manufacturer's choice, shall be used for this purpose.]~~

~~5.3. Survival space required after the test or tests~~

~~5.3.1. After undergoing each of the tests referred to in paragraph above, the cab of the vehicle shall exhibit a survival space allowing accommodation of the manikin defined in [annex 3, appendix 2] on the seat, [when the latter is in its median position], without contact between the manikin and non-resilient parts. To facilitate installation, the manikin may be inserted in dismantled form and assembled in the cab. For this purpose, the seat shall be adjusted to its most rearward position and the manikin completely assembled and so placed that its H point coincides with the R point. [The seat shall then be moved forward to its median position for the assessment of the survival space].~~

~~5.3.2. The space so defined shall be verified for every seat provided by the manufacturer.~~

~~5.4. Other conditions~~

~~5.4.1. During the tests the components by which the cab is secured to the chassis frame may be distorted or broken, provided that the cab remains attached to the chassis frame.~~

~~5.4.2. None of the doors shall open during the tests, but the doors shall not be required to open after testing.~~

~~5.5. [Tests B and C need not be carried out if the manufacturer can show by calculations of the strength of the component parts of the cab or by other means that the roof or rear wall will not undergo deformation dangerous to the occupants (penetration into the survival space) if subjected to the conditions of tests B and C].~~

6. MODIFICATION AND EXTENSION OF APPROVAL OF THE VEHICLE TYPE

6.1. Every modification of the vehicle type shall be notified to the administrative department which approved the vehicle type. The department may then either:

- 6.1.1. consider that the modifications made are unlikely to have an appreciable adverse effect, and that in any case the vehicle still complies with the requirements; or
- 6.1.2. require a further test report from the Technical Service responsible for conducting the tests.
- 6.2. Confirmation or refusal of approval, specifying the alterations, shall be communicated by the procedure specified in paragraph 4.3. above to the Contracting Parties to the Agreement which apply this Regulation.
- 6.3. The competent authority issuing an extension of approval shall assign a series number for such an extension and inform thereof the other Parties to the 1958 Agreement applying this Regulation by means of a communication form conforming to the model in annex 1 to this Regulation.

7. CONFORMITY OF PRODUCTION

The conformity of production procedures shall comply with those set out in the Agreement, appendix 2 (E/ECE/324-E/ECE/TRANS/505/Rev.2), with the following requirements:

- 7.1. Every vehicle bearing an approval mark as prescribed under this Regulation shall conform to the vehicle type approved as regards features capable of affecting the characteristics of the cab.
- 7.2. In order to verify conformity as prescribed in paragraph 7.1. above, serially-produced vehicles bearing the approval mark required by this Regulation may be subjected to random checks.
- 7.3. As a general rule, the checks aforesaid shall be confined to the taking of measurements. However, the vehicles shall if necessary be subjected to the tests described in **paragraphs 5 annex 3** to this Regulation.
- 7.4 The authority which has granted type approval may at any time verify the conformity control methods applied in each production facility. The normal frequency of these verifications shall be [one every two years]**

8. PENALTIES FOR NON-CONFORMITY OF PRODUCTION

- 8.1. The approval granted in respect of a vehicle type, pursuant to this Regulation, may be withdrawn if the requirement laid down in paragraph 7.1. above is not complied with, or if the cab fails to pass the checks prescribed in paragraph 7.2. and 7.3. above.
- 8.2. If a Party to the Agreement applying this Regulation withdraws an approval it has previously granted, it shall forthwith so notify the other Contracting Parties applying this Regulation by means of a communication form conforming to the model in annex 1 to this Regulation.

9. PRODUCTION DEFINITELY DISCONTINUED

If the holder of the approval completely ceases to manufacture a type of vehicle approved in accordance with this Regulation, he shall so inform the authority which granted the approval. Upon receiving the relevant communication, that authority shall inform thereof the other Parties to the 1958 Agreement which apply this Regulation by means of a communication form conforming to the model in Annex 1 to this Regulation.

10. TRANSITIONAL PROVISIONS

10.1. As from the official date of entry into force of the 03 series of amendments, no Contracting Party applying this Regulation shall refuse to grant ECE approval under this Regulation as amended by the 03 series of amendments.

~~10.2. As from 1 October 2002 Contracting Parties applying this Regulation shall grant ECE approvals only if the requirements of this Regulation, as amended by the 02 series of amendments are satisfied.~~

10.2. As from [xxxx] months after the date of entry into force, Contracting Parties applying this Regulation shall grant ECE approvals to new types of cabs only if the cab type to be approved meets the requirements of this Regulation, as amended by the 03 series of amendments.

~~10.3. As from 1 October 2006 Contracting Parties applying this Regulation may refuse to recognize approvals which were not granted in accordance with the 02 series of amendments to this Regulation.~~

10.3 Starting [xxx] months after the entry into force of the 03 series of amendments to this Regulation, Contracting Parties applying this Regulation may refuse (national or regional type approval and may refuse) first national or regional registration (first entry into service) of a vehicle which does not meet the requirements of the 03 series of amendments to this Regulation.

11. NAMES AND ADDRESSES OF TECHNICAL SERVICES RESPONSIBLE FOR CONDUCTING APPROVAL TESTS, AND OF ADMINISTRATIVE DEPARTMENTS

The Parties to the Agreement which apply this Regulation shall communicate to the Secretariat of the United Nations the names and addresses of the technical services conducting approval tests, and of the administrative departments which grant approval and to which forms certifying approval or extension, or refusal or withdrawal of approval, issued in other countries, are to be sent.

Annex 1

ECE TYPE-APPROVAL DOCUMENTATION

Part 1

Model Information documents

MODEL INFORMATION DOCUMENT pursuant to Regulation No. 29 relating to type-approval of the cab.

The following information, if applicable, must be supplied in triplicate and include a list of contents. Any drawings must be supplied in appropriate scale and in sufficient detail on size A4 or on a folder of A4 format. Photographs, if any, must show sufficient detail.

1. GENERAL
 - 1.1. Make (trade name of manufacturer):
 - 1.2. Type:
 - 1.3. Means of identification of type, if marked on the vehicle:
 - 1.3.3. Location of that marking
 - 1.4. Category of vehicle (a):
 - 1.5. Name and address of manufacturer:
 - 1.6. Address(es) of assembly plant(s):
2. GENERAL CONSTRUCTION CHARACTERISTICS OF THE VEHICLE
 - 2.1. Photographs and/or drawings of a representative vehicle:
 - 2.2. Dimensional drawing of the whole vehicle:
 - 2.3. Number of axles and wheels:
 - 2.6. Position and arrangement of the engine:
 - 2.7. Driving cab (cab-over-engine or bonnet) (b):
 - 2.8. Hand of drive:

3. **MASSES AND DIMENSIONS (in kg and mm) (refer to drawing where applicable)**
 - 3.1. **Technically permissible maximum laden mass stated by the manufacturer:**
 - 3.2 **Technical permissible maximum mass for the front axle or axles of the vehicle:**

4. **CAB**
 - 4.1. **Type of cab: (normal/sleeper/top-sleeper)**
 - 4.2. **Materials used and methods of construction:**
 - 4.3 **Door configuration and number of doors:**
 - 4.4 **Drawings of latches and hinges and their position in the doors:**
 - 4.3. **Number of seats:**
 - 4.3 **R-points:**
 - 4.4. **Detailed description of the cab of the vehicle type including its dimensions, configuration and constituent materials and its attachment to any chassis frame:**
 - 4.5. **Drawings of the cab and those parts of its interior arrangement which have an influence on the residual space:**

5. **STEERING**
 - 5.1 **Schematic diagram(s) of the steering control(s):**
 - 5.2 **Range and method of adjustment (if any), of the steering control**

Explanatory notes:

- 1/** **Delete where not applicable (there are cases where nothing needs to be deleted when more than one entry is applicable).**

- (a)** **As defined in annex 7 to the Consolidated Resolution of Construction of Vehicles (R.E.3). (TRANS/WP.29/78/Rev.1/Amend.2)**

- (b)** **Cab-over-engine means a configuration in which more than half of the engine length is rearward of the foremost point of the windshield base and the steering wheel hub in the forward quarter of the vehicle length.**

Annex 1, Part 2

COMMUNICATION
(maximum format: A4 (210 x 297 mm))

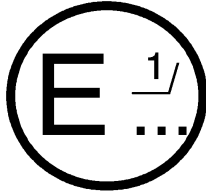

Issued by: Name of administration:

.....
.....
.....

concerning: 2/ APPROVAL GRANTED

APPROVAL EXTENDED

APPROVAL REFUSED

APPROVAL WITHDRAWN

PRODUCTION DEFINITELY DISCONTINUED

of a vehicle type with regard to protection of the occupants of the cab of a ~~commercial~~ vehicle pursuant to Regulation No. 29.

Approval No. ...

Extension No. ...

1. Trade name or mark of the vehicle:.....
2. Vehicle type:.....
3. Manufacturer's name and address:
.....
4. If applicable, name and address of manufacturer's representative:
.....
5. Brief description of the cab's design and method of attachment:
6. Vehicle submitted for approval on:

- 7. Technical service responsible for conducting approval tests:
.....
- 8. Date of report issued by that service:
- 9. Number of report issued by that service:.....
- ~~10.~~ Tests passed by cab: [~~A / B / C /~~]2/
- ~~11.~~**10** Approval granted/refused/extended/withdrawn. 2/
- ~~12.~~**11** Position of approval mark on the vehicle:
- ~~13.~~**12** Place:
- ~~14.~~**13** Date:
- ~~15.~~**14** Signature:.....

The list of documents deposited with the Administrative Service which has granted approval is annexed to this communication and may be obtained on request.

- 1/ Distinguishing number of the country which has granted/extended/refused/withdrawn approval (see approval provisions in the Regulation).
- 2/ Strike out what does not apply.

Annex 2

ARRANGEMENTS OF APPROVAL MARKS

Model A

(See paragraph 4.4. of this Regulation)

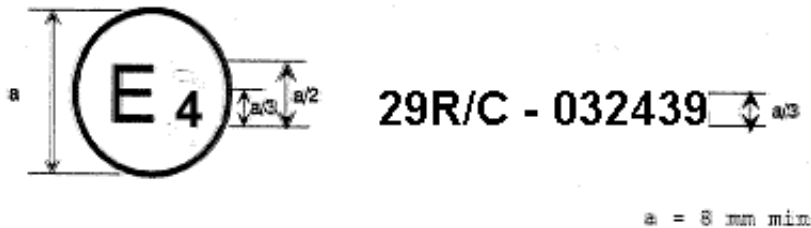

Note: The marking picture not modified

The above approval mark affixed to a vehicle shows the vehicle type concerned has with regard to the protection of the occupants of the cab of a commercial vehicle, been approved in the Netherlands (E 4), under the number ~~03249~~ 02249 and that the cab of the vehicle ~~meets the requirements of test C.~~ The first two digits of the approval number indicate the Regulation No. 29 already included the ~~03~~ 02 series of amendments when the approval was given.

Model B

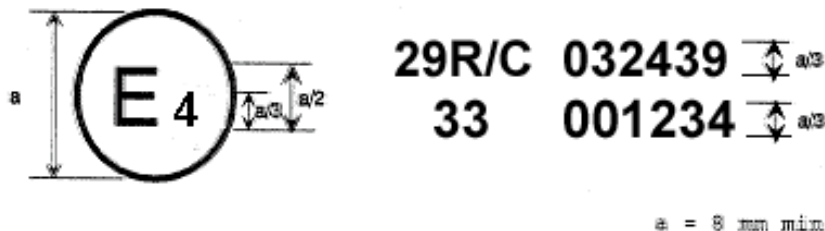

Note: The marking picture not modified

The above approval mark affixed to a vehicle shows that the vehicle type concerned has been approved in the Netherlands (E 4) pursuant to Regulations Nos. 29 and 33 1/. ~~The cab of the vehicle meets the requirements of test C.~~ The approval numbers indicate that on the dates on which these approvals were granted, Regulation No. 29 included the 03 series of amendments and Regulation No. 33 was in its original version.

1/ The later number is given as an example only

Annex 3

~~TEST PROCEDURE~~ TEST SET-UP

1. Doors

Before the test the doors of the cab shall be closed but not locked.

2. Engine

For test A the engine, or a model equivalent to in mass, dimensions and mounting corresponding to the engine of smallest overall dimensions normally installed in vehicles that the cab being tested is used with, shall be fitted.

3. Cab

The cab shall be equipped with the steering mechanism, steering wheel, instrument-panel and the driver and passenger seats.

4. Cab locks

Before the test the cab locks, if any, shall be locked.

5. Steering mechanism

5.1 The steering mechanism shall be of the most rigid design available and the steering wheel the largest diameter steering wheel existing and of the most rigid design for which the cab is designed.

5.2. The steering wheel, if it is adjustable, in any plane or arc, shall be adjusted so that hub is in the middle drive position in terms of both the vertical and horizontal adjustment position and locked there.

5.2.1. In all circumstances when considering steering wheel adjustment it is only the limit of adjustment for normal driving that should be considered and should not include adjustment provided for any other purpose.

6. Seats

6.1 Horizontally adjustable seats are adjusted to the middle position.

6.2 Vertically adjustable seats are moved so that the distance from the hinge-point of the dummy to the R-point corresponds to half of the vertical adjustment distance of the seat or the next height adjustment position above this.

6.3 Seats with adjustable springing are adjusted to their middle position or the next position above this.

6.3.1 Seats with adjustable springing and indicated weight-related setting positions are adjusted so that the springing position which corresponds to the weight of the dummy is obtained, or the next highest setting position.

6.4. The seat-back, if adjustable, shall be locked in a position corresponding to a rearward inclination as close as possible to 25° from the vertical of the torso reference line of the dummy described in annex 7 appendix 1, unless otherwise specified by the manufacturer.

7. Positioning of the manikin

7.1. A manikin of the same dimensions and as a Hybrid III 95th percentile male dummy shall be positioned in the driver's seat in the following manner:

7.1.2. Centrally on the seat as far back as is possible in a normal sitting position and so the centre plane of the seat and of the manikin lie in the same vertical plane.

7.1.3. This shall be achieved by adjusting the seat back or by the use suitable padding between the seat and the manikin or a combination of both.

7.1.4. The manikin shall maintain an upright posture.

7.1.5. The torso shall be securely fastened to the seat back with sticky tape or other suitable means.

7.1.6. The feet of the manikin shall be positioned flat on the floor between the operating pedals in as natural position as possible and taped in place.

7.1.7. The feet and legs shall, as far as is practicable, be kept parallel to each other.

7.1.8. The hands of the manikin shall be placed on the steering wheel at the ten-to-two position and taped in place.

7.1.9. The hands and arms shall, as far as is practicable, be kept parallel with each other.

8. Anchorage of the cab

For test A, the cab shall be mounted on a vehicle. For tests B and C, the cab shall at the manufacturers choice be mounted either on a vehicle or on a separate frame. The vehicle or frame shall be secured in the manner prescribed in [appendix 1] to this annex.

9. Securing of the vehicle or frame

9.1 The vehicle or frame shall be secured in the manner prescribed in appendix 1 to this annex.

Annex 3 – Appendix 1

INSTRUCTIONS FOR SECURING VEHICLE TO TEST BED

~~1. Frontal impact~~

~~Test A shall be applied to a cab mounted on the vehicle in the following way (see figure 1 below).~~

~~1.1. Anchoring chains or ropes~~

~~Each anchoring chain or rope shall be of steel and shall be capable of withstanding a tractive load of at least 10 tons.~~

~~1.2. Blocking of the chassis frame~~

~~The longitudinal members of the chassis frame shall be supported on wooden blocks across their full width and over a length of not less than 150 mm. The front edges of the blocks must not be situated forward of the rearmost point of the cab, nor rearward of the mid point of the wheel base. At the manufacturer's request the chassis frame shall be set in the attitude it takes up when loaded.~~

~~1.3. Longitudinal attachment~~

~~Rearward movement of the chassis frame shall be limited by chains or ropes A attached to the front of the chassis frame symmetrically in relation to its longitudinal axis, the points of attachment being not less than 600 mm apart. The chains or ropes shall when tensioned form a downward angle of not more than 25 ° with the horizontal and their projection on a horizontal plane shall form an angle of not more than 10 ° with the longitudinal axis of the vehicle. The chains or ropes may cross one another.~~

~~1.4. Lateral attachment~~

~~Lateral movement shall be limited by chains or ropes B attached to the chassis frame symmetrically in relation to its longitudinal axis. The points of attachment to the chassis shall be not more than 5 m and not less than 3 m from the front of the vehicle. The chains or ropes shall when tensioned form a downward angle of not more than 20 ° with the horizontal and their projection on a horizontal plane shall form an angle of not less than 25 ° and not more than 45 ° with the longitudinal axis of the vehicle.~~

~~1.5. Tensioning of chains or ropes and rear attachment~~

~~The chain or rope C shall to begin with be placed under a load of approximately 100 kgf. All slack in the four chains or ropes A and B shall then be taken up and chain or rope C shall be subjected to a tensile stress of not less than 1,000 kgf. The angle of chain or rope C with the horizontal shall not exceed 15 °. A vertical blocking force of not less than 50 kgf shall be applied at point D between the chassis frame and the ground.~~

~~1.6. Equivalent mounting~~

~~At the request of the manufacturer the test may be carried out with the cab mounted on a special frame, on condition that this method of mounting is shown to be equivalent to mounting on the vehicle.~~

~~2. Roof strength~~

~~2.1 Cab mounted on the vehicle~~

~~Measures shall be taken to ensure that the vehicle does not shift appreciably during the test. For this purpose the hand brake shall be applied, a gear engaged and the front wheels wedged with chocks. Deformation of the various components of the suspension (springs, tyres, etc.) shall be eliminated by means of rigid members.~~

~~2.2. Cab mounted on a frame~~

~~Measures shall be taken to ensure that the frame does not shift appreciably during the test.~~

~~3. Strength of rear wall~~

~~3.1. Cab mounted on the vehicle~~

~~Measures shall be taken to ensure that the vehicle does not shift appreciably during the test. For this purpose the hand brake shall be applied, a gear engaged and the front wheels wedged with chocks.~~

~~3.2. Cab mounted on a frame~~

~~Measures shall be taken to ensure that the frame does not shift appreciably during the test.]~~

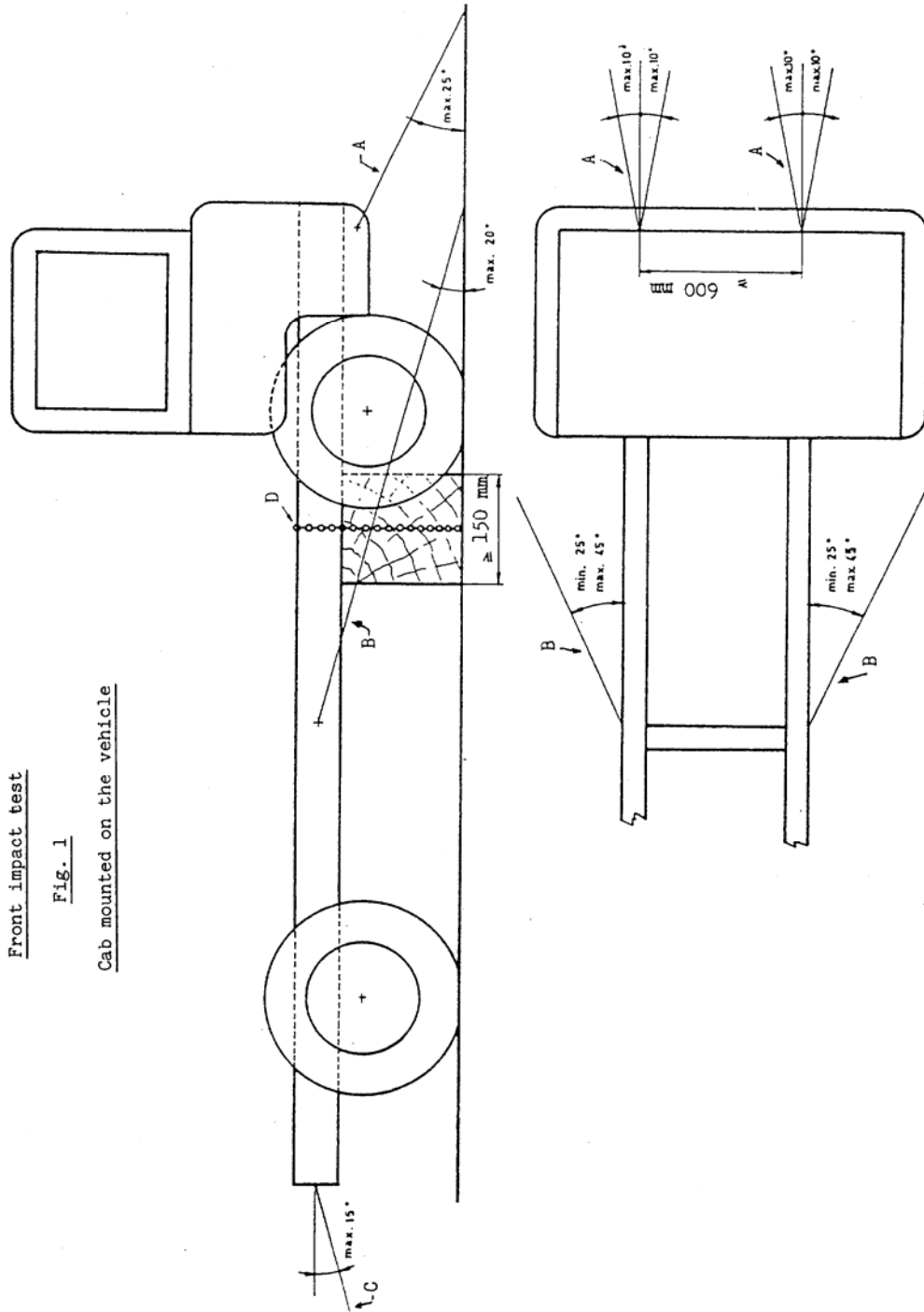

Front impact test

Fig. 1

Cab mounted on the vehicle

Annex 4

TEST PROCEDURE FOR TEST A - FRONT IMPACT

~~[4.1. Description of the swing bob~~

- ~~4.1.1. The swing bob shall be made of steel and its mass shall be evenly distributed; its mass shall be $1,500 \pm 250$ kg. Its striking surface, rectangular and flat, shall be 2500 mm wide and 800 mm high. Its edges shall be rounded to a radius of curvature of not less than 1.5 mm.~~
- ~~4.1.2. The swing bob assembly shall be of rigid construction. The swing bob shall be freely suspended by two beams rigidly attached to it and spaced not less than 1,000 mm apart. The beams shall be of "I" section with a web height of not less than 100 mm or shall be of a section having at least an equivalent moment of inertia. The beams shall be not less than 3,500 mm long from the axis of suspension to the geometric centre of the bob.~~
- ~~4.1.3. The swing bob shall be so positioned that in the vertical position~~
- ~~4.1.3.1. its striking face is in contact with the foremost part of the vehicle;~~
- ~~4.1.3.2. its centre of gravity is $50 \pm 5/0$ mm below the R point of the driver's seat, and~~
- ~~4.1.3.3. its centre of gravity is in the median longitudinal plane of the vehicle .~~
- ~~4.1.4. The swing bob shall strike the cab at the front in the direction towards the rear of the cab. The direction of impact shall be horizontal and shall be parallel to the median longitudinal plane of the vehicle. The impact energy shall be 3,000 mkgf for vehicles of a permissible maximum mass up to 7,000 kg and 4,500 mkgf for vehicles for which the permissible maximum mass exceeds this value.]~~

Annex 5

TEST PROCEDURE FOR TEST B - 90° ROLLOVER (IMPACT ON THE A-PILLAR)

Annex 6

TEST PROCEDURE FOR TEST C - 180° ROLLOVER

Annex 7

PROCEDURE FOR DETERMINING THE "H" POINT AND THE ACTUAL TORSO ANGLE FOR SEATING POSITIONS IN MOTOR VEHICLES

1. PURPOSE

The procedure described in this annex is used to establish the "H" point location and the actual torso angle for one or several seating positions in a motor vehicle and to verify the relationship of measured data to design specifications given by the vehicle manufacturer. ^{3/}

2. DEFINITIONS

For the purposes of this annex:

2.1. "Reference data" means one or several of the following characteristics of a seating position:

2.1.1. the "H" point and the "R" point and their relationship,

2.1.2. the actual torso angle and the design torso angle and their relationship.

2.2. "Three-dimensional 'H' point machine" (3-D H machine) means the device used for the determination of "H" points and actual torso angles. This device is described in appendix 1 to this annex;

2.3. "'H' point" means the pivot centre of the torso and thigh of the 3-D H machine installed in the vehicle seat in accordance with paragraph 4. below. The "H" point is located in the centre of the centreline of the device which is between the "H" point sight buttons on either side of the 3-D H machine. The "H" point corresponds theoretically to the "R" point (for tolerances see paragraph 3.2.2. below). Once determined in accordance with the procedure described in paragraph 4., the "H" point is considered fixed in relation to the seat-cushion structure and to move with it when the seat is adjusted;

2.4. "'R' point" or "seating reference point" means a design point defined by the vehicle manufacturer for each seating position and established with respect to the three-dimensional reference system;

2.5. "Torso-line" means the centreline of the probe of the 3-D H machine with the

^{3/} In any seating position other than front seats where the "H" point cannot be determined using the "three-dimensional 'H' point machine" or procedures, the "R" point indicated by the manufacturer may be taken as a reference at the discretion of the competent authority.

probe in the fully rearward position;

- 2.6. "Actual torso angle" means the angle measured between a vertical line through the "H" point and the torso line using the back angle quadrant on the 3-D H machine. The actual torso angle corresponds theoretically to the design torso angle (for tolerances see paragraph 3.2.2. below);
- 2.7. "Design torso angle" means the angle measured between a vertical line through the "R" point and the torso line in a position which corresponds to the design position of the seat-back established by the vehicle manufacturer;
- 2.8. "Centre plane of occupant" (C/LO) means the median plane of the 3-D H machine positioned in each designated seating position; it is represented by the co-ordinate of the "H" point on the "Y" axis. For individual seats, the centre plane of the seat coincides with the centre plane of the occupant. For other seats, the centre plane of the occupant is specified by the manufacturer;
- 2.9. "Three dimensional reference system" means a system as described in appendix 2 to this annex;
- 2.10. "Fiducial marks" are physical points (holes, surfaces, marks or indentations) on the vehicle body as defined by the manufacturer;
- 2.11. "Vehicle measuring attitude" means the position of the vehicle as defined by the co-ordinates of fiducial marks in the three-dimensional reference system.

3. REQUIREMENTS

3.1. Data presentation

For each seating position where reference data are required in order to demonstrate compliance with the provisions of the present Regulation, all or an appropriate selection of the following data shall be presented in the form indicated in appendix 3 to this annex:

- 3.1.1. the co-ordinates of the "R" point relative to the three-dimensional reference system;
- 3.1.2. the design torso angle;
- 3.1.3. all indications necessary to adjust the seat (if it is adjustable) to the measuring position set out in paragraph 4.3. below.

3.2. Relationship between measured data and design specifications

- 3.2.1. The co-ordinates of the "H" point and the value of the actual torso angle obtained by the procedure set out in paragraph 4. below shall be compared, respectively, with the co-ordinates of the "R" point and the value of the design torso angle indicated by the vehicle manufacturer.
- 3.2.2. The relative positions of the "R" point and the "H" point and the relationship between the design torso angle and the actual torso angle shall be considered satisfactory for the seating position in question if the "H" point, as defined by its co-ordinates, lies within a square of 50 mm side length with horizontal and vertical sides whose diagonals intersect at the "R" point, and if the actual torso angle is within 5 degree of the design torso angle.
- 3.2.3. If these conditions are met, the "R" point and the design torso angle, shall be used to demonstrate compliance with the provisions of this Regulation.
- 3.2.4. If the "H" point or the actual torso angle does not satisfy the requirements of paragraph 3.2.2. above, the "H" point and the actual torso angle shall be determined twice more (three times in all). If the results of two of these three operations satisfy the requirements, the conditions of paragraph 3.2.3. above shall apply.
- 3.2.5. If the results of at least two of the three operations described in paragraph 3.2.4. above do not satisfy the requirements of paragraph 3.2.2. above, or if the verification cannot take place because the vehicle manufacturer has failed to supply information regarding the position of the "R" point or regarding the design torso angle, the centroid of the three measured points or the average of the three measured angles shall be used and be regarded as applicable in all cases where the "R" point or the design torso angle is referred to in this Regulation.

4. PROCEDURE FOR "H" POINT AND ACTUAL TORSO ANGLE DETERMINATION

- 4.1. The vehicle shall be preconditioned at the manufacturer's discretion, at a temperature of 20 ± 10 °C to ensure that the seat material reaches room temperature. If the seat to be checked has never been sat upon, a 70 to 80 kg person or device shall sit on the seat twice for one minute to flex the cushion and back. At the manufacturer's request, all seat assemblies shall remain unloaded for a minimum period of 30 minutes prior to installation of the 3-D H machine.
- 4.2. The vehicle shall be at the measuring attitude defined in paragraph 2.11. above.

4.3. The seat, if it is adjustable, shall be adjusted first to the rearmost normal driving or riding position, as indicated by the vehicle manufacturer, taking into consideration only the longitudinal adjustment of the seat, excluding seat travel used for purposes other than normal driving or riding positions. Where other modes of seat adjustment exist (vertical, angular, seat-back, etc.) these will be then adjusted to the position specified by the vehicle manufacturer. For suspension seats, the vertical position shall be rigidly fixed corresponding to a normal driving position as specified by the manufacturer.

4.4. The area of the seating position contacted by the 3-D H machine shall be covered by a muslin cotton, of sufficient size and appropriate texture, described as a plain cotton fabric having 18.9 threads per cm² and weighing 0.228 kg m² or knitted or non-woven fabric having equivalent characteristics.

If the test is run on a seat outside the vehicle, the floor on which the seat is placed shall have the same essential characteristics 4/ as the floor of the vehicle in which the seat is intended to be used.

4.5. Place the seat and back assembly of the 3-D H machine so that the centre plane of the occupant (C/LO) coincides with the centre plane of the 3-D H machine. At the manufacturer's request, the 3-D H machine may be moved inboard with respect to the C/LO if the 3-D H machine is located so far outboard that the seat edge will not permit levelling of the 3-D H machine.

4.6. Attach the foot and lower leg assemblies to the seat pan assembly, either individually or by using the T-bar and lower leg assembly. A line through the "H" point sight buttons shall be parallel to the ground and perpendicular to the longitudinal centre plane of the seat.

4.7. Adjust the feet and leg positions of the 3-D H machine as follows:

4.7.1. Designated seating position: driver and outside front passenger.

4.7.1.1. Both feet and leg assemblies shall be moved forward in such a way that the feet take up natural positions on the floor, between the operating pedals if necessary. Where possible the left foot shall be located approximately the same distance to the left of the centre plane of the 3-D H machine as the right foot is to the right. The spirit level verifying the transverse orientation of the 3-D H machine is brought to the horizontal by readjustment of the seat pan if necessary, or by adjusting the leg and foot assemblies towards the rear. The line passing through the "H" point sight buttons shall be maintained perpendicular to the longitudinal centre plane of the seat.

4.7.1.2. If the left leg cannot be kept parallel to the right leg and the left foot cannot be supported by the structure, move the left foot until it is supported. The alignment of the sight buttons shall be maintained.

4/ Tilt angle, height difference with a seat mounting, surface texture, etc.
2007-04-30

4.7.2. Designated seating position: outboard rear

For rear seats or auxiliary seats, the legs are located as specified by the manufacturer. If the feet then rest on parts of the floor which are at different levels, the foot which first comes into contact with the front seat shall serve as a reference and the other foot shall be so arranged that the spirit level giving the transverse orientation of the seat of the device indicates the horizontal.

4.7.3. Other designated seating positions:

The general procedure indicated in paragraph 4.7.1. above shall be followed except that the feet shall be placed as specified by the vehicle manufacturer.

4.8. Apply lower leg and thigh weights and level the 3-D H machine.

4.9. Tilt the back pan forward against the forward stop and draw the 3-D H machine away from the seat-back using the T-bar. Reposition the 3-D H machine on the seat by one of the following methods:

4.9.1. If the 3-D H machine tends to slide rearward, use the following procedure. Allow the 3-D H machine to slide rearward until a forward horizontal restraining load on the T-bar is no longer required i.e. until the seat pan contacts the seat-back. If necessary, reposition the lower leg.

4.9.2. If the 3-D H machine does not tend to slide rearward, use the following procedure. Slide the 3-D H machine rearwards by applying a horizontal rearward load to the T-bar until the seat pan contacts the seat-back (see figure 2 of appendix 1 to this annex).

4.10. Apply a 100 ± 10 N load to the back and pan assembly of the 3-D H machine at the intersection of the hip angle quadrant and the T-bar housing. The direction of load application shall be maintained along a line passing by the above intersection to a point just above the thigh bar housing (see figure 2 of appendix 1 to this annex). Then carefully return the back pan to the seat-back. Care must be exercised throughout the remainder of the procedure to prevent the 3-D H machine from sliding forward.

4.11. Install the right and left buttock weights and then, alternately, the eight torso weights. Maintain the 3-D H machine level.

4.12. Tilt the back pan forward to release the tension on the seat-back. Rock the 3-D H machine from side to side through 10 degrees arc (5 degrees to each side of the vertical centre plane) for three complete cycles to release any accumulated friction between the 3-D H machine and the seat.

During the rocking action, the T-bar of the 3-D H machine may tend to diverge

from the specified horizontal and vertical alignment. The T-bar must therefore be restrained by applying an appropriate lateral load during the rocking motions. Care shall be exercised in holding the T-bar and rocking the 3-D H machine to ensure that no inadvertent exterior loads are applied in a vertical or fore and aft direction.

The feet of the 3-D H machine are not to be restrained or held during this step. If the feet change position, they should be allowed to remain in that attitude for the moment.

Carefully return the back pan to the seat-back and check the two spirit levels for zero position. If any movement of the feet has occurred during the rocking operation of the 3-D H machine, they must be repositioned as follows:

Alternately, lift each foot off the floor the minimum necessary amount until no additional foot movement is obtained. During this lifting, the feet are to be free to rotate; and no forward or lateral loads are to be applied. When each foot is placed back in the down position, the heel is to be in contact with the structure designed for this.

Check the lateral spirit level for zero position; if necessary, apply a lateral load to the top of the back pan sufficient to level the 3-D H machine's seat pan on the seat.

- 4.13. Holding the T-bar to prevent the 3-D H machine from sliding forward on the seat cushion, proceed as follows:
- (a) return the back pan to the seat-back;
 - (b) alternately apply and release a horizontal rearward load, not to exceed 25 N, to the back angle bar at a height approximately at the centre of the torso weights until the hip angle quadrant indicates that a stable position has been reached after load release. Care shall be exercised to ensure that no exterior downward or lateral loads are applied to the 3-D H machine. If another level adjustment of the 3-D H machine is necessary, rotate the back pan forward, re-level, and repeat the procedure from paragraph 4.12.
- 4.14. Take all measurements:
- 4.14.1. The co-ordinates of the "H" point are measured with respect to the three-dimensional reference system.
 - 4.14.2. The actual torso angle is read at the back angle quadrant of the 3-D H machine with the probe in its fully rearward position.
- 4.15. If a re-run of the installation of the 3-D H machine is desired, the seat assembly should remain unloaded for a minimum period of 30 minutes prior to the re-run. The 3-D H machine should not be left loaded on the seat assembly longer than the

time required to perform the test.

4.16. If the seats in the same row can be regarded as similar (bench seat, identical seats, etc.) only one "H" point and one "actual torso angle" shall be determined for each row of seats, the 3-D H machine described in appendix 1 to this annex being seated in a place regarded as representative for the row. This place shall be:

4.16.1. in the case of the front row, the driver's seat;

4.16.2. in the case of the rear row or rows, an outer seat.

Annex 7 - Appendix 1

DESCRIPTION OF THE THREE-DIMENSIONAL "H" POINT MACHINE */

(3-D H machine)

1. Back and seat pans

The back and seat pans are constructed of reinforced plastic and metal; they stimulate the human torso and thigh and are mechanically hinged at the "H" point. A quadrant is fastened to the probe hinged at the "H" point to measure the actual torso angle. An adjustable thigh bar, attached to the seat pan, establishes the thigh centreline and serves as a baseline for the hip angle quadrant.

2. Body and leg elements

Lower leg segments are connected to the seat pan assembly at the T-bar joining the knees, which is a lateral extension of the adjustable thigh bar. Quadrants are incorporated in the lower leg segments to measure knee angles. Shoe and foot assemblies are calibrated to measure the foot angle. Two spirit levels orient the device in space. Body element weights are placed at the corresponding centres of gravity to provide seat penetration equivalent to a 76 kg male. All joints of the 3-D H machine should be checked for free movement without encountering noticeable friction.

*/ For details of the construction of the 3-D H machine refer to Society of Automotive Engineers (SAE), 400 Commonwealth Drive, Warrendale, Pennsylvania 15096, United States of America.

The machine corresponds to that described in ISO Standard 6549 : 1980.

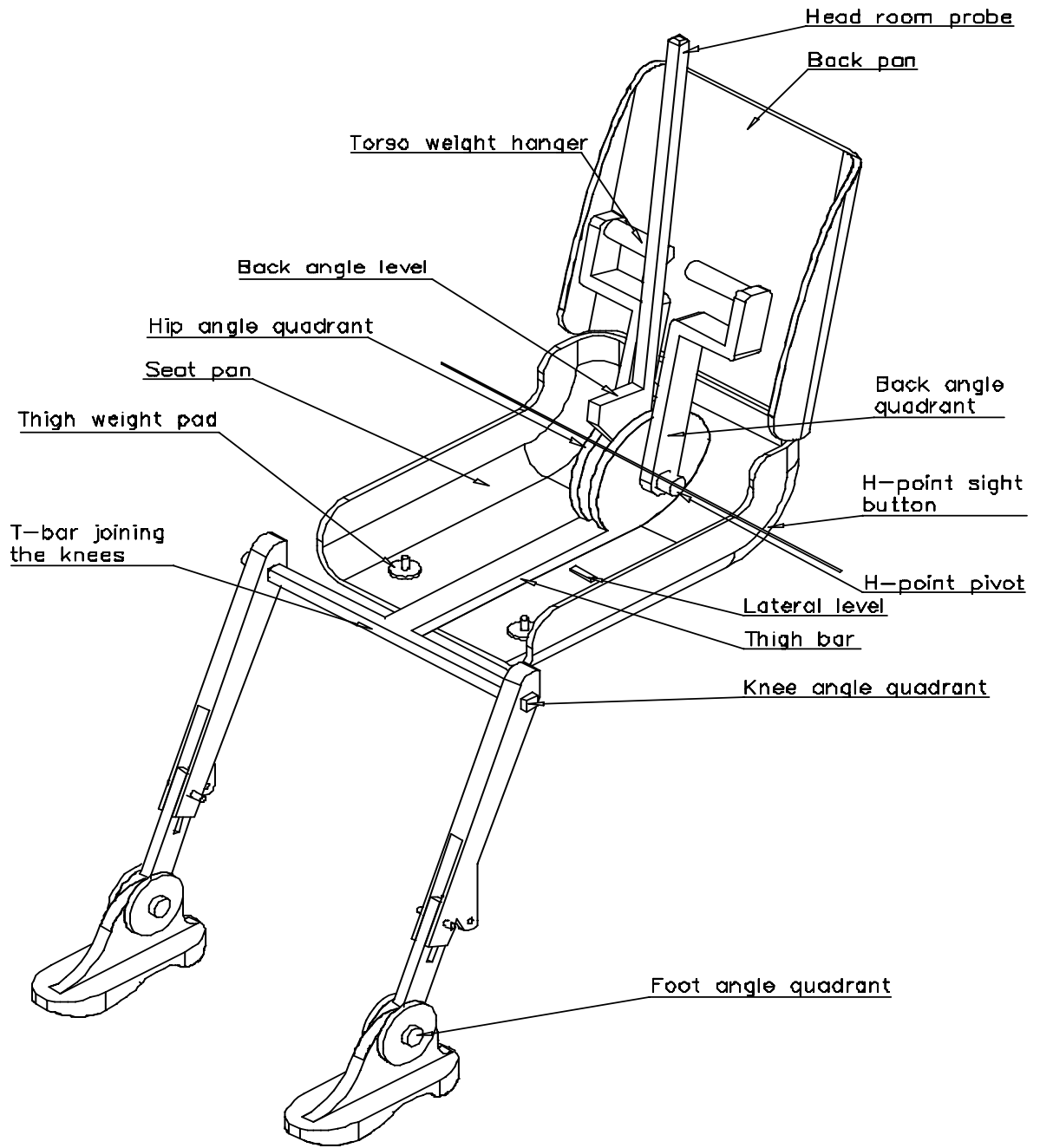

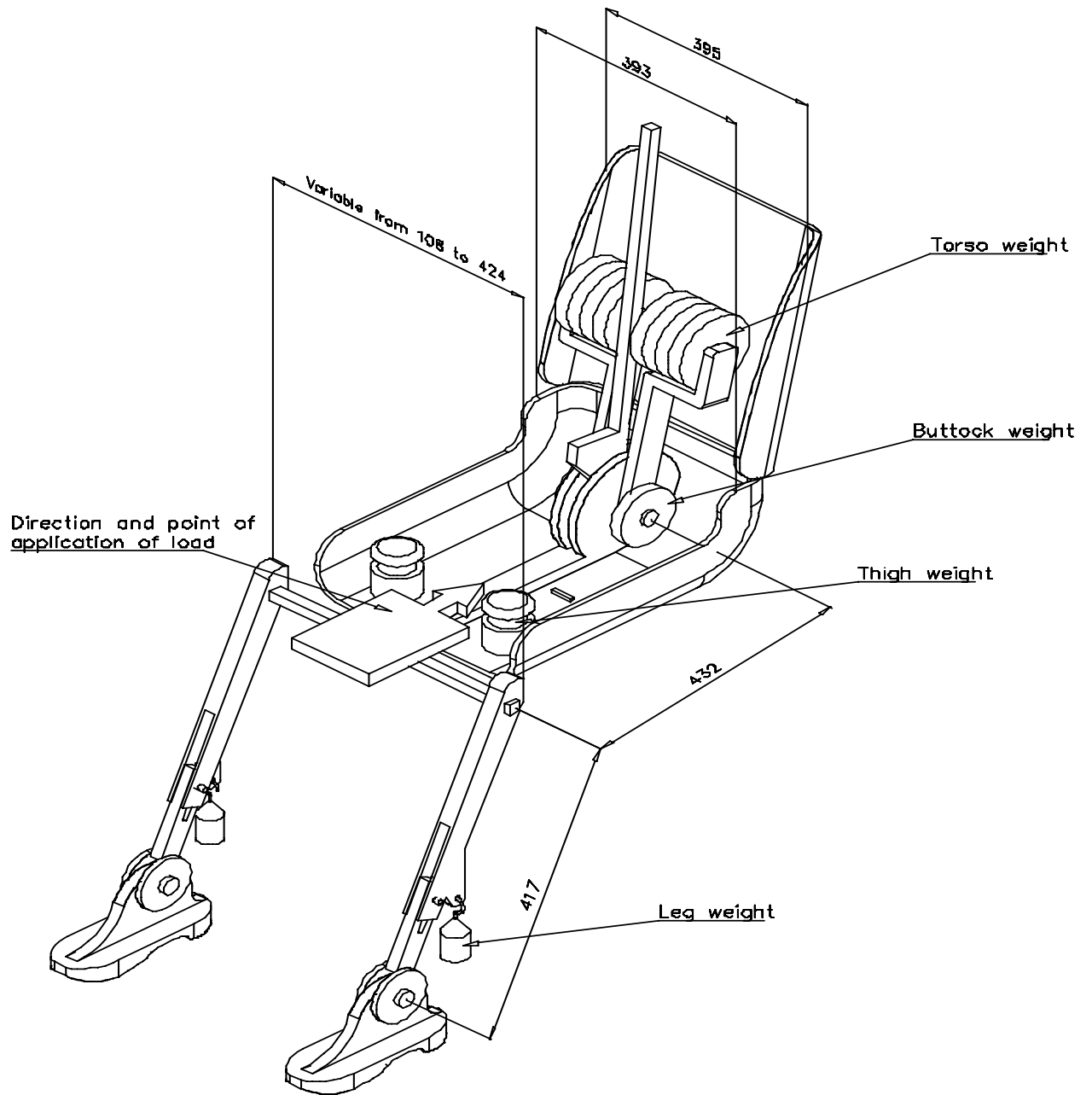
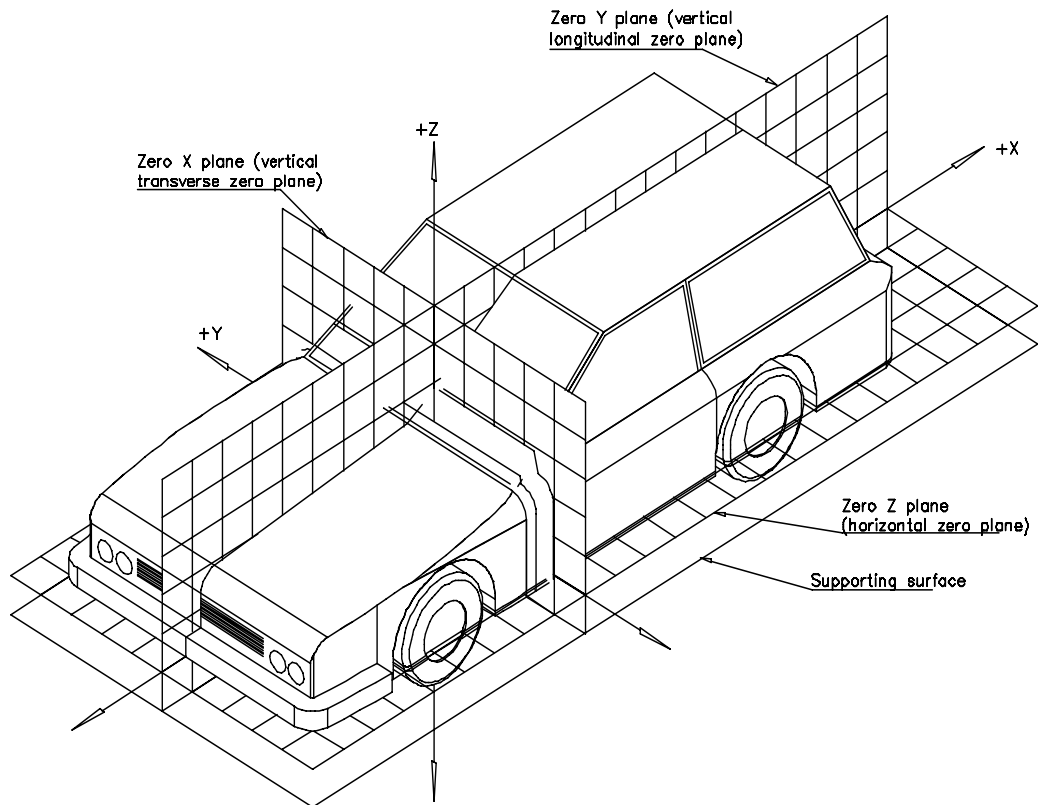

Figure 2 - Dimensions of the 3-D H machine elements and load distribution (Dimensions in millimeters)

Annex 7 - Appendix 2

THREE-DIMENSIONAL REFERENCE SYSTEM

1. The three-dimensional reference system is defined by three orthogonal planes established by the vehicle manufacturer (see figure). */
2. The vehicle measuring attitude is established by positioning the vehicle on the supporting surface such that the co-ordinates of the fiducial marks correspond to the values indicated by the manufacturer.
3. The co-ordinates of the "R" point and the "H" point are established in relation to the fiducial marks defined by the vehicle manufacturer.



*/ The reference system corresponds to ISO standard 4130 : 1978.

Annex 8

REFERENCE DATA CONCERNING SEATING POSITIONS

1. Coding of reference data

Reference data are listed consecutively for each seating position. Seating positions are identified by a two-digit code. The first digit is an Arabic numeral and designates the row of seats, counting from the front to the rear of the vehicle. The second digit is a capital letter which designates the location of the seating position in a row, as viewed in the direction of forward motion of the vehicle; the following letters shall be used:

L = left
C = centre
R = right

2. Description of vehicle measuring attitude

2.1. Co-ordinates of fiducial marks

X

Y

Z

3. List of reference data

3.1. Seating position:

3.1.1. Co-ordinates of "R" point

X

Y

Z

3.1.2. Design torso angle:

3.1.3. Specification for seat adjustment */

horizontal:

vertical:

angular:

torso angle:

Note: List reference data for further seating positions under 3.2., 3.3., etc.

*/ Strike out what does not apply.
2007-04-30

Annex X

Rear wall strength (test C)

————— The rear wall of the cab shall be capable of withstanding a static load of 200 kgf per tonne of permissible useful load. This load shall be applied by means of a rigid barrier perpendicular to the longitudinal median axis of the vehicle, covering at least the whole of the cab rear wall situated above the chassis frame, and moving parallel to that axis.