



**Economic and Social
Council**

Distr.
GENERAL

TRANS/WP.15/2004/29
19 February 2004

Original: ENGLISH

ECONOMIC COMMISSION FOR EUROPE

INLAND TRANSPORT COMMITTEE

Working Party on the Transport of Dangerous Goods
(Seventy-sixth session, Geneva,
3-5 May 2004,
agenda item 5)

PROPOSALS FOR AMENDMENTS TO ANNEXES A AND B OF ADR

Definition of Bowsers under ADR

Transmitted by the Government of the United Kingdom

Summary:	A paper seeking guidance on how to define certain small mobile receptacles known within the United Kingdom as 'bowsers'.
Decision to be taken:	How to define 'bowsers' under ADR, and specifically whether it would be beneficial to create a set of guidelines for the certification of 'bowsers' as tanks or IBCs.

Introduction

1. Since the 1940s there have been in use within the United Kingdom, small mobile receptacles used principally for the transport of water or diesel fuel. These receptacles, typically under 3000 litres capacity, are called 'bowsers' after the company that first constructed this type of receptacle. There is no United Kingdom legal definition of a 'bowser'. It is known that similar equipment is used in a number of other European countries.

2. A 'bowser' may be constructed in several different ways. To meet environmental protection requirements, an inner receptacle is fitted inside an outer receptacle to provide appropriate 'bundling'. An inner receptacle may or may not be permanently fixed to the outer receptacle. The combined receptacle is then mounted on to a frame and/or running gear to which it may, or may not, be permanently attached, which is then towed behind a vehicle or carried as a load on the bed of a transport unit to a site where it can then be used to dispense liquid (see Annex).

The problem

3. The Government of the United Kingdom is seeking clarification on how 'bowsers' should be defined in the context of ADR and would welcome the opinions of other delegations. We are aware that within the United Kingdom, the Netherlands and Italy this type of receptacle has, on an individual design basis, been tested and certified as an IBC. However, in the United Kingdom, receptacles of the same design type, but over 3000 litres capacity, have been certified as tanks.

4. Most 'bowsers' consist of three distinctly separate components, namely an inner receptacle to contain the product, an outer receptacle to provide the bundling to which discharge equipment is fitted, and a frame to carry that receptacle. The receptacle, when tested separately, could meet the definition of an IBC and successfully pass the appropriate design type tests. However, the receptacle is sometimes permanently fastened to the frame or to running gear, in which case it would then appear to meet the definition of a 'tank'.

5. There are four possible options for the definition of 'bowsers':

1. Treat all 'bowsers' as tanks irrespective of capacity;
2. Treat all 'bowsers' up to 3000 litres capacity as IBCs and over that capacity as tanks;
3. Treat each 'bowser' on an individual basis as either a tank or an IBC, on the basis of harmonized guidelines on making that decision;
4. Create a new receptacle type - a 'bowser' - and define the necessary technical requirements.

6. The design of 'bowsers' does not necessarily fit conveniently into existing definitions of either an IBC or a tank, and may share several characteristics of both. Manufacturers, users and competent authorities may not share the same interpretation of the same piece of equipment. Therefore, the United Kingdom considers that agreed guidelines would ensure fewer inconsistencies in how 'bowsers' are defined and certified within individual countries, thus avoiding potential restrictions on trade.

7. For domestic purposes the United Kingdom competent authority issued the following interim guidelines on certification of 'bowsers' as IBC:

- must meet all the requirements for IBCs as set out in the European Agreement concerning the International Carriage of Dangerous Goods by Road (ADR);
- must only be used for UN1202 (diesel and heating oils) and 1223 (kerosene);
- certificates will only be valid until 31 December 2008 (*in order to resolve ADR interpretation*);
- the possibility of extending the validity, subject to continuing to meet the requirements of ADR, will be considered in the future;
- a sample of 'bowsers' will be subject to periodic re-inspection by the competent authority;
- Any change to the service equipment, other than like for like replacement, is not permitted unless approved by the Competent Authority;
- the IBC should not be fastened to a motor vehicle or trailer, other than temporarily for safety in transport. Such temporary fastenings include purpose designed retention devices with or without screw fasteners. If the IBC is permanently fitted to a motor vehicle or trailer, for example by welding, the 'bowser' will no longer meet the definitions of an IBC and the certificate will, by default, be invalid;
- certification as an IBC is only recognized within the United Kingdom; the competent authorities of other countries may not recognize these receptacles as an IBC.

'Bowsers' that do not meet these requirements are certified as tanks.

8. The Government of the United Kingdom proposes that a new Note 3 be inserted after the definition of IBCs in chapter 1.2 as follows:

NOTE 3: receptacles generally referred to as 'bowsers' may be considered as IBCs if they meet the following conditions, otherwise they shall be considered as tanks:

- must meet all the requirements for IBCs as set out in the European Agreement concerning the International Carriage of Dangerous Goods by Road (ADR);
 - must only be used for UN1202 (diesel and heating oils) and 1223 (kerosene);
 - the 'bowser' should not be fastened to a motor vehicle or trailer, other than temporarily for safety in transport. Such temporary fastenings include purpose designed retention devices with or without screw fasteners. If the IBC is permanently fitted to a motor vehicle or trailer, for example by welding, the 'bowser' will no longer meet the definitions of an IBC.
-

Annex

How a Bowser is constructed:

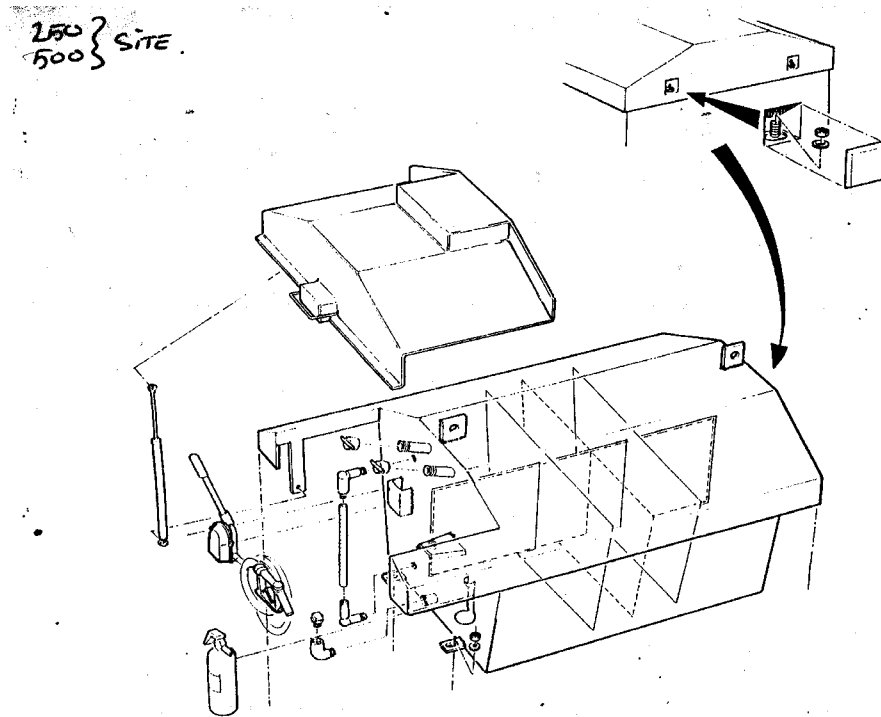

The Most Common Type of Bowser: