



**Economic and Social
Council**

Distr.
GENERAL

TRANS/WP.29/GRSG/2003/21/Add.1
29 January 2004

ENGLISH
Original: ENGLISH
ENGLISH AND FRENCH ONLY

ECONOMIC COMMISSION FOR EUROPE

INLAND TRANSPORT COMMITTEE

World Forum for Harmonization of Vehicle Regulations (WP.29)

Working Party on General Safety Provisions (GRSG)

(Eighty-sixth session, 19-23 April 2004,
agenda item 3.)

**PROPOSAL FOR SUPPLEMENT 1 TO THE DRAFT 02 SERIES OF AMENDMENTS TO
REGULATION No. 107**

(M2 and M3 vehicles)

Transmitted by the expert from the International Organization
of Motor Vehicle Manufacturers (OICA)

Note: The text reproduced below was prepared by the expert from OICA following the request of GRSG (TRANS/WP.29/GRSG/64, para. 9) in order to consolidate the minor amendments to Regulation No. 107, agreed at the eighty-fourth and eighty-fifth sessions, with the remainder of the amendments proposed by OICA to document TRANS/WP.29/GRSG/2003/21, which goes beyond the task to merge existing requirements of Regulations Nos. 36, 52 and 107, together with European Community Directive 2001/85/EC. It is presented in two parts. Part 1 contains proposals which have been agreed by GRSG. Part 2 contains proposals which are still to be agreed. It replaces documents TRANS/WP.29/GRSG/2003/2 and TRANS/WP.29/GRSG/2003/22.

Note: This document is distributed to the Experts on General Safety Provisions only.

A. PROPOSAL

PART 1 – Amendments already agreed by GRSG at its eighty-fourth and eighty-fifth sessions

Sources: TRANS/WP.29/GRSG/2003/22 as amended by GRSG at its eighty-fifth session.

* TRANS/WP.29/2003/71,

** Informal documents Nos. 12 to 14 distributed at the eighty-fifth session of GRSG, as amended, (agreed for submission to WP.29 and AC.3)

*** TRANS/WP.29/GRSG/2003/2 as amended, (agreed for submission to WP.29 and AC.3)

Paragraph 2.1.4., replace "Low floor bus" by "Low floor vehicle".

Paragraph 2.15.2., amend to read:

"2.15.2. the space above the surface of any step or staircase (except where the surface of the step is contiguous with that of a gangway or access passageway), or"

Paragraph 2.38., amend to read:

"2.38. "Separate compartment" means a space in the vehicle which may be occupied by passengers or crew and which is separated from any other passenger or crew space, except where any partition allows passengers to see into the next passenger space, and is connected by a gangway without doors."

Annex 1, part 1, appendices 1 and 2, item 5.4., insert a reference to a new foot note 2/ and its corresponding footnote 2/, to read:

"2/ In the case of an articulated vehicle, specify the number of seats in each rigid section."

Annex 3,

Paragraph 7.2.3.2., should be deleted.

Paragraphs 7.2.3.3. to 7.2.3.3.1.2., renumber as paragraphs 7.2.3.2. to 7.2.3.2.1.2.

Paragraph 7.6.1.5., amend to read: *

"7.6.1.5. Each rigid section of an articulated vehicle shall be treated as a separate vehicle for the purpose of determination of the minimum number and the position of exits. The connecting passage between them shall not be considered as an exit. The number of passengers shall be determined for each rigid section. The plane, which lies through the geometric centre of the turning section floor, and perpendicular to the longitudinal axis of a vehicle, when it moves straight, shall be considered as the border between sections."

Paragraph 7.6.1.7.2., amend to read: ***

"7.6.1.7.2. One or two seats are permitted alongside the driver for additional people, in which case both of the exits referred to in paragraph 7.6.1.7.1. shall be doors.

The driver's door shall be accepted as the emergency door for the occupants of those seats, provided that it is possible to move a test gauge from the occupants' seats to the exterior of the vehicle through the driver's door (see annex 4, figure 27).

Verification of the access to the driver's door shall be subject to the requirements of paragraph 7.7.3.2., by using the test gauge having a dimension of 600x400 mm, as described in paragraph 7.7.3.3.

The door provided for the passengers shall be in the side of the vehicle opposite to that containing the driver's door and shall be accepted as the emergency door for the driver.

Up to five additional seats may be fitted in a compartment incorporating the driver's compartment, provided that the additional seats and the space for these seats comply with all requirements of this Regulation and at least one door giving access to the passenger compartment complies with the requirements of paragraph 7.6.3. for emergency doors."

Paragraphs 7.6.1.9.1. and 7.6.1.9.2., amend to read:***

"7.6.1.9.1. it satisfies the requirements relating to the dimensions of emergency door indicated in paragraph 7.6.3.1.;

7.6.1.9.2. it fulfils the requirements indicated in paragraph 7.6.1.7.2.;"

Insert a new paragraph 7.6.1.9.3., to read:***

7.6.1.9.3. the space reserved for the driver's seat shall communicate with the main passengers' compartment through an appropriate passage; such requirement shall be deemed to be fulfilled if the test gauge described in paragraph 7.7.5.1. can move unobstructed from the gangway, until the front end of the gauge reaches the vertical plane tangential to the foremost point of the driver's seat back (this seat being situated in its rearmost longitudinal position) and, from this plane, the panel described in paragraph 7.6.1.7.2. could be moved to the emergency door in the direction established by such paragraph (see annex 4, figure 28) with seat and steering wheel adjustment in their mid position."

Paragraph 7.6.2.3., amend to read:

"... of the vehicle is substantially the same. (This shall not imply the need to provide additional exits over and above the number specified in paragraph 5.6.1.)."

Paragraph 7.6.2.4., amend to read:

"7.6.2.4. At least one exit shall be situated either ..."

Paragraph 7.6.3.2., amend to read:

"7.6.3.2. Vehicles of Class A or B may meet either the requirements shown in paragraph 7.6.3.1. (Class A meeting Class I requirements and Class B meeting Class II and III requirements) or those contained in annex 6, paragraph 1.1."

Paragraph 7.6.4.6., amend to read:

"...
... standing 1 m behind the vehicle. Driving mirrors may be used to meet this requirement provided that the field of view required for driving is still met."

Paragraph 7.6.5.4., amend to read:

"... in the normal driving position in any normal ambient lighting condition, to warn ..."

Paragraph 7.6.10.7., should be deleted.

Paragraph 7.6.10.8., renumber as paragraph 7.6.10.7.

Paragraph 7.6.10.9. (former), renumber as paragraph 7.6.10.8. and amend to read: *

"7.6.10.8. when the passenger door is opened, the retractable step shall be securely held in the extended position. When a mass of 136 kg is placed in the centre of a single step or a mass of 272 kg is placed in the centre of a double step the deflection at any point on the step, measured relative to the body of vehicle, shall not exceed 10 mm."

Paragraph 7.6.11.1., amend to read:

"7.6.11.1. Each emergency exit shall be marked, inside and outside the vehicle, by an international representative symbol."

Paragraphs 7.7.1.1. and 7.7.1.2., amend to read:

"7.7.1.1. The free space extending inwards into the vehicle from the side wall in which the door is mounted shall permit the free passage of one test gauge having the dimensions of either test gauge 1 or test gauge 2 specified in annex 4 figure 1.

The test gauge shall be maintained parallel with the door aperture as it is moved from the starting position, where the plane of the face nearest to the interior of the vehicle is tangential to the outermost edge of the aperture, to the position where it touches the first step, after which it shall be kept at right angles to the probable direction of motion of a person using the entrance."

7.7.1.2. (Reserved)"

Paragraph 7.7.1.3., amend to read:

"7.7.1.3. When the centreline of this test gauge is touching the surface of the step or floor, it shall be retained in that position."

Paragraph 7.7.1.6., amend to read:

"7.7.1.6. The free passage clearance for this figure shall not include any space extending to 300 mm in front of any uncompressed seat cushion of a forward or rearward facing seat, or 225 mm in the case of sideways-facing seats, and to the height of the top of the seat cushion (see annex 4, figure 1)."

Paragraph 7.7.1.8., amend to read:

"7.7.1.8. However, one or more folding seat(s) for use by the crew may obstruct the access passage to a service door when in the position of use provided that:"

Paragraph 7.7.1.12., amend to read:

"7.7.1.12. Gangways and access passages shall be covered with a slip-resistant material"

Paragraph 7.7.2.1., amend to read:

"7.7.2.1. Except as provided for in paragraph 7.7.2.4., the free space between the gangway and the emergency door ..."

Paragraph 7.7.5.6., amend to read:

"7.7.5.6. Folding seats allowing passengers to sit in the gangway shall not be permitted. Folding seats shall, however, be permitted in other areas of the vehicle so long as they do not obstruct the passage down the gangway of the gangway test gauge when in the open (seating) position."

Paragraph 7.7.7.2., amend to read:

"7.7.7.2. The height of a step shall be measured at the centre of its width at the outer edge, the tyre equipment and pressure being as specified by the manufacturer for the technically permissible maximum mass (MT)."

Paragraph 7.7.8.3., amend to read: **

"7.7.8.3. Height of seat cushion (dimension H, see annex 4, figure 11a)

The height of the ... less than 350 mm at the wheel arches (taking into account the allowances permitted in paragraph 7.7.8.6.2.) and at the engine/transmission compartment."

Paragraph 7.7.8.5.1., amend to read: **

"7.7.8.5.1 For a seat behind a partition or other rigid structure other than a seat, a minimum clear space in front of each passenger seat shall be provided as shown in annex 4, figure 13. A partition whose contour corresponds approximately to that of the inclined seat back may intrude into this space as provided by paragraph 7.7.8.4. In the case of seats alongside the driver's seat in vehicles with up to 22 passengers, intrusion of the dashboard, instrument panel, windscreen, sun visor, seat belts and seat belt anchorages shall be allowed."

Insert a new paragraph 7.7.8.5.2., to read:**

"7.7.8.5.2. For a seat behind a seat and/or a seat facing the gangway, a minimum clear foot space of at least 300 mm depth and a width according to paragraph 7.7.8.1.1., shall be provided as shown in annex 4, figure 11b. The local presence in this space of seat legs and of intrusions as provided by paragraph 7.7.8.6 shall be permitted provided that adequate space remains for the passengers' feet. This foot space may partly be situated in and/or above the gangway but shall not create any obstruction when measuring the minimum gangway-width in accordance with paragraph 7.7.5. In the case of seats alongside the driver's seat in vehicles with up to 22 passengers, intrusion of the seat belts and seat belt anchorages shall be allowed. "

Paragraphs 7.7.8.5.2 and 7.7.8.5.2.1 (former), renumber as paragraphs 7.7.8.5.3.and 7.7.8.5.3.1.**

Paragraph 7.7.8.6.3.2., amend to read:

"7.7.8.6.3.2. in the case of the upper part of the outboard seating position, a zone with triangular cross-section whose apex is situated 700 mm from the top and whose base is 100 mm in width (see figure 15); The space needed for safety belts and their anchorages and for the sun visor is also excluded."

Paragraph 7.7.8.6.3.3., amend to read:

"7.7.8.6.3.3. in the case of the foot well of an outboard seat, a zone of a cross-sectional area not exceeding, 0.02 m² (0.03 m² for low floor vehicles) and having a maximum width not exceeding 10 cm (15 cm for low floor vehicles) (see annex 4, figure 16)."

Paragraph 7.7.9.1., replace the value "1200 mm" by "1500 mm", and add at end:

"The provisions of paragraph 7.6.11.4. apply to any textual markings used."

Paragraph 7.11.1.4., amend to read:

"7.11.1.4. The clearance between a hand-rail or hand-hold, along the majority of its length, and the adjacent part of the vehicle body or walls shall be at least 40 mm. However, in the case of a handrail on a door or a seat, or in the access passage of a vehicle of Class II, III or B, a minimum clearance of 35 mm shall be permitted."

Paragraph 7.11.2., amend to read:

"7.11.2. Additional requirements for handrails and handholds for vehicles designed to carry standing passengers"

Paragraph 7.12.1., amend to read:

"7.12.1. Where any seated passenger is likely to be thrown forward into a stepwell as a result of heavy braking, either a guard or, in the case of a vehicle of Class A or B, a seat belt shall be fitted. Where the guard shall have a minimum height ..."

Annex 4,

Figure 11, renumber as figure 11a:**

Insert a new figure 11b, to read: **

"Figure 11b
SPACE FOR FEET OF SEATED PASSENGERS BEHIND A SEAT AND/OR A SEAT
FACING THE GANGWAY
(see annex 3, paragraph 7.7.8.5.2.)

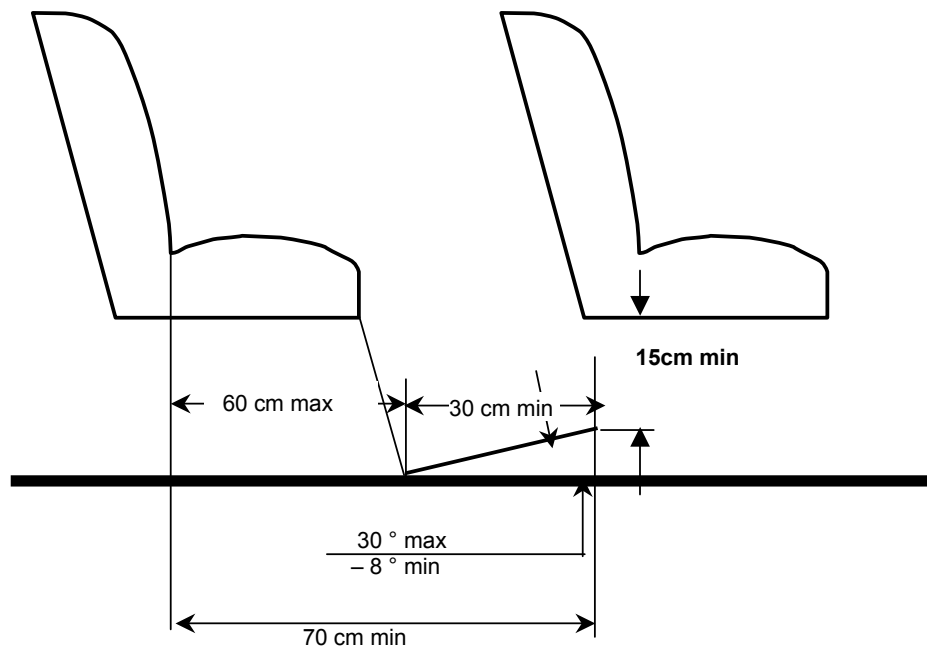

Figure 13, the title, amend to read: **

"Figure 13
SPACE FOR SEATED PASSENGERS BEHIND A PARTITION OR OTHER RIGID
STRUCTURE OTHER THAN A SEAT
(see annex 3, paragraph 7.7.8.5.1.)"

Insert new figures 27 and 28, to read: ***

"Figure 27
ACCESS TO DRIVER'S DOOR
(See annex 3, paragraph 7.6.1.7.2.)

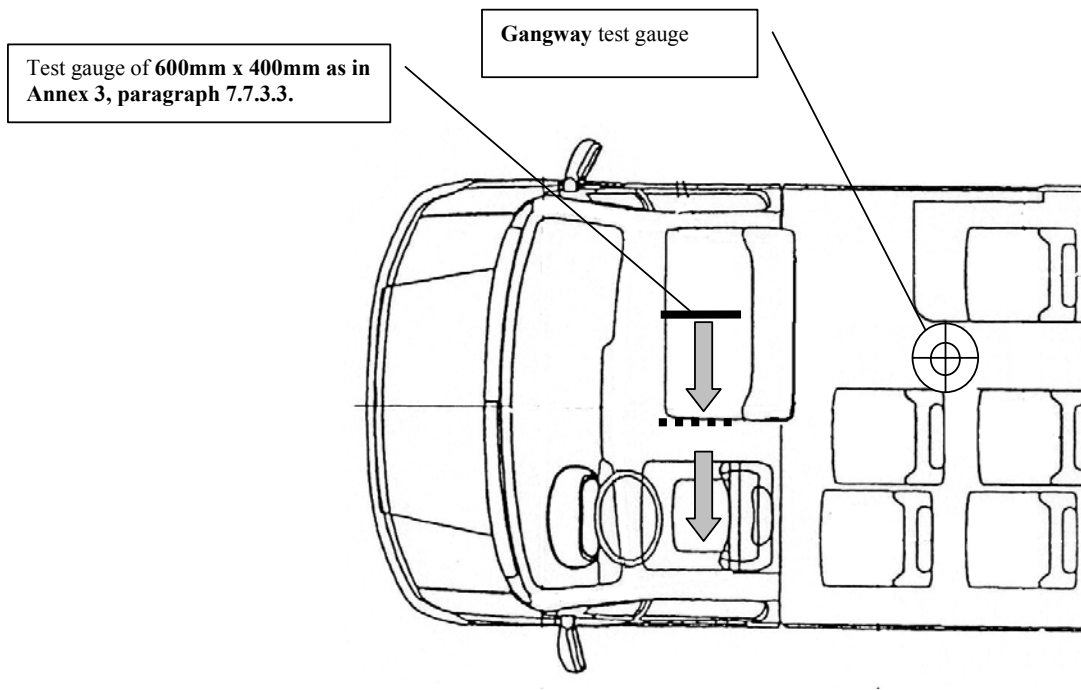
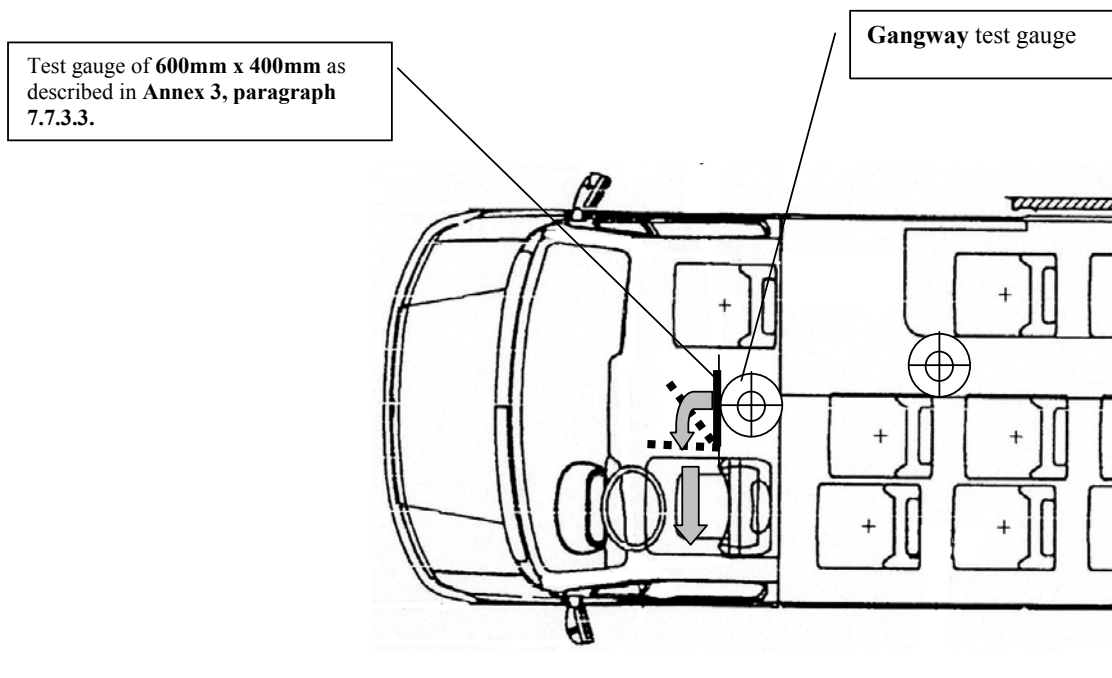

Figure 28
ACCESS TO DRIVER'S DOOR
(See Annex 3, paragraph 5.7.2.4.2.)



Annex 7, the title, amend to read:

"ALTERNATIVE REQUIREMENTS FOR VEHICLES HAVING A CAPACITY NOT EXCEEDING 22 PASSENGERS"

Annex 7, after the title, insert the following text:

"Vehicles having a capacity not exceeding 22 passengers shall comply with the requirements of annex 3 with the exception that:

- in place of paragraph 7.6.3.1. of annex 3, a vehicle may comply with paragraph 1.1. of this annex;
- in place of paragraph 7.6.2. of annex 3, a vehicle may comply with paragraph 1.2. of this annex."

Annex 8, paragraph 3.11.2.3., amend to read:

"3.11.2.3. The lowering process shall be capable of being stopped and immediately reversed ..."

Annex 12, paragraph 1.2. (ii), amend to read:

"1.2. (i)...

(ii) "low voltage circuits" means circuits supplied with accumulator battery and with a charger outlet of nominal 12 V, 24 V or 42 V voltage."

PART 2 – Amendments requiring further discussion by GRSG

The modifications to the consolidated text of the Regulation are marked in **bold** characters.

Annex 3,

Paragraph 7.2.2.2.5., amend to read: (see informal document No. 27 distributed at the eighty-fifth session of GRSG)

"7.2.2.2.5. the area 300 mm in front of all seats other than folding seats, except **where in the case of** a sideways-facing seat ~~is situated above the wheel arch~~, in which case this dimension may be reduced to 225 mm. In the case of variable seating arrangements, of any seat when considered to be in use, see paragraph 7.2.2.4"

Paragraph 7.5., should be deleted.

Paragraph 7.6.2.1., amend to read:

"7.6.2.1. half of the vehicle. **This does not preclude:**"

Insert new paragraphs 7.6.2.1.1. to 7.6.2.1.4., to read:

- "7.6.2.1.1. **the provision of a specially designed door in the rear or side faces of a vehicle for use in place of a service door by wheelchair passengers, or;**
- 7.6.2.1.2. **the provision of an additional service door in the rear face of a vehicle principally for loading/unloading of goods or luggage, but which could be used by passengers where circumstances so require, or**
- 7.6.2.1.3. **the provision of one or more additional service doors on the opposite side of the vehicles in the case of vehicles designed for use in circumstances which require loading/unloading on both sides. Examples of such circumstances include vehicles for airside use at airports, vehicles for use on multimodal transport systems using island platforms, or vehicles which cross borders to countries which do not drive on the same side of the road as the country in which the vehicle is to be licensed for operation. Vehicles so equipped shall be provided with control(s) which allow the driver to inhibit normal operation of the doors which are not currently in use, or**
- 7.6.2.1.4. **the provision of a service door in the rear face of a Class A or B vehicle."**

Paragraph 7.6.4.6., should be deleted.

(All provisions dealing with internal and external visibility should be transferred into Regulation No. 46.)

Paragraph 7.7.8.5.1., amend to read:

- "7.7.8.5.1 For a seat behind a partition or other rigid structure other than a seat, a minimum clear space in front of each **required passenger seating space (as defined in paragraph 7.7.8.6.)** shall be provided as shown in annex 4, figure 13. A partition whose contour corresponds approximately to that of the inclined seat back may intrude into this space as provided by paragraph 7.7.8.4. In the case of seats alongside the driver's seat in vehicles with up to 22 passengers, intrusion of the dashboard, instrument panel, **gear change control**, windscreen, sun visor, seat belts and seat belt anchorages shall be allowed."

Insert a new paragraph 7.7.8.5.3., to read: (see informal document No. 27 distributed at the eighty-fifth session of GRSG)

- "7.7.8.5.3. However, at least two in Class I and Class II and one in Class A forward or rearward facing seats specifically intended and marked for passengers with reduced mobility other than wheelchair users shall be provided in that part of the bus which is most suitable for boarding. These seats shall be designed for passengers with reduced mobility so as to provide enough space, shall have suitably designed and placed handholds to facilitate entry and exit of the seat and provide communication in accordance with paragraph 7.7.9. from the seated position."

Paragraph 7.7.8.6.1., first sub paragraph., amend to read: (see informal document No. 17 distributed at the eighty-fifth session of GRSG)

"7.7.8.6.1. In the case of single deck vehicles, over each seating position and, except in the case of the front row seats in a vehicle not exceeding 22 passengers, its associated foot space, there shall be measured a free space with a height of not less than 900 mm measured from the highest point of the uncompressed seat cushion and at least 1350 mm from the mean level of the floor in the foot space. In the case of vehicles to which paragraph 7.7.1.10. applies, and also for the first row of seats in a vehicle not exceeding 22 passengers, these dimensions may be reduced to 1200 mm measured from the floor where the feet of the seated passenger rest." (remainder unchanged).

Insert a new paragraph 7.8.5., to read:

"7.8.5. Control of the mandatory interior lighting [shall] be by manual switches under the control of the driver or automatically controlled."

Annex 4, figure 1, amend to read:

"Figure 1
ACCESS TO SERVICE DOORS

(see annex 3, paragraph 7.7.1.)

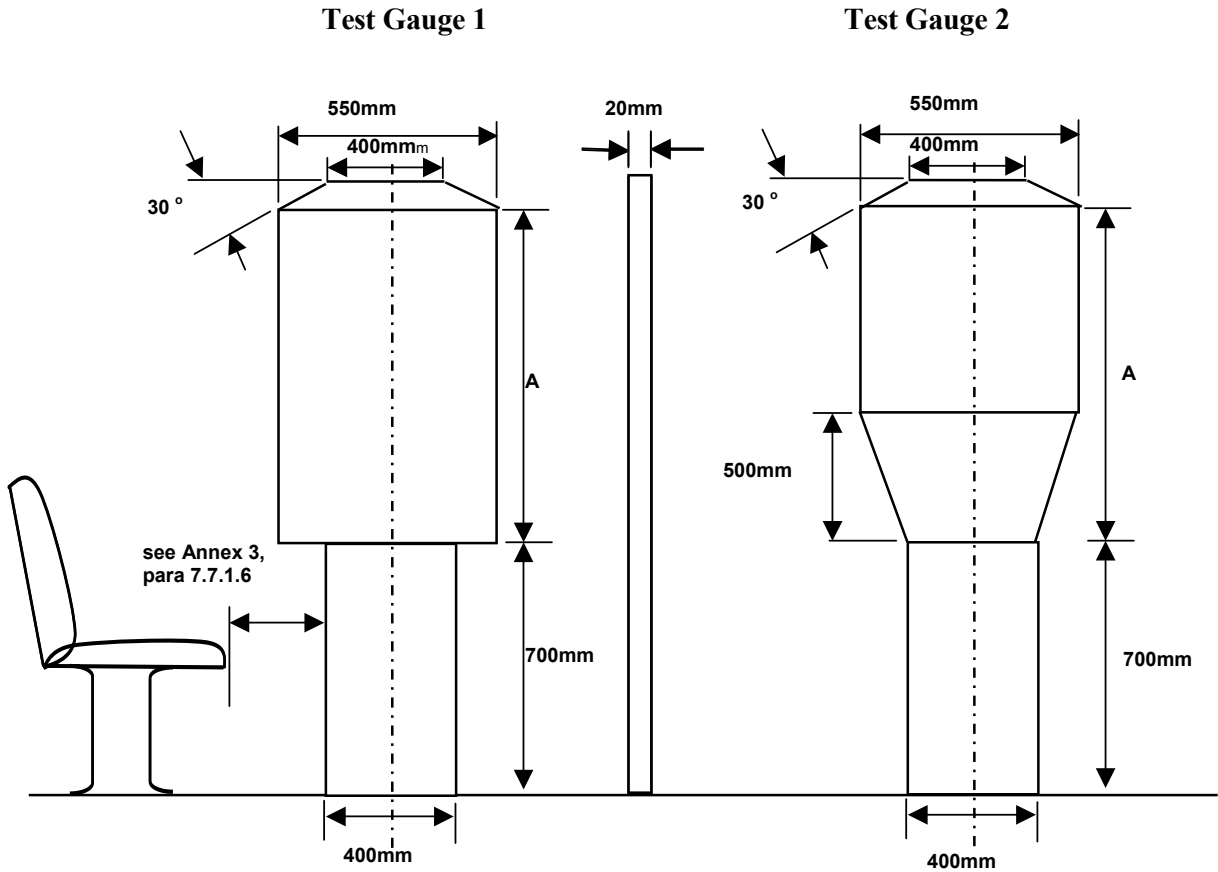

Vehicle Class	Height of the upper panel (mm) (Dimension "A", figure 1)		Total height
	Test gauge 1	Test gauge 2	
Class A	950 (*)	950	1650
Class B	700 (*)	950	1400
Class I	1100	1100	1800
Class II	950	1100	1650
Class III	850	1100	1550

(*) For vehicles having a capacity not exceeding 22 passengers, the lower panel may be displaced relative to the upper panel provided that it is in the same direction."

Figure 11b,

(The diagram shown in Part A of this document is believed to better reflect the intention of GRSG than that contained in the minutes. GRSG should consider both versions and decide which one to use.)

Annex 7, paragraph 1.1.1., amend to read: (see informal document No. 27 distributed at the eighty-fifth session of GRSG)

"1.1.1. A vehicle to which paragraph **7.7.1.10.** of annex 3 applies shall meet the requirements of paragraph 7.6.3.1. of annex 3 or paragraph 1.1. of this annex as regards emergency windows and escape hatches, and the following minimum requirements as regards service doors and emergency doors:"

Annex 8 paragraphs 3.11.2.4. to 3.11.2.4.2, amend to read: (see informal document No. 27 distributed at the eighty-fifth session of GRSG)

"3.11.2.4. **Any kneeling system that** is fitted to a vehicle shall **neither:**"

Insert new paragraphs 3.11.2.4.1. and 3.11.2.4.2., to read:

"**3.11.2.4.1.** allow the vehicle to be driven at a speed of more than 5 km/h when the vehicle is lower than the normal height of travel, **nor**

3.11.2.4.2. allow the vehicle to be raised or lowered when the operation of the service door is prevented for any reason."

Paragraph 3.11.2.4., replace "or" by "and not". amend to

(See informal document No. 27 distributed at the eighty-fifth session of GRSG)

Paragraph 3.11.4.3.4., amend to read:

"3.11.4.3.4. The horizontal movement of a ramp shall be interrupted **when a mass of 15 kg is placed upon it.**"

* * *

B. JUSTIFICATION

Annex 3

Re. paragraph 2.15.2.

Clarification. At the top of a flight of steps, it is impossible to define where the step ends and the floor begins.

Re. paragraph 2.38.

Clarification.

Re. paragraph 7.2.2.2.5.

Text aligned with new text of 7.7.1.6. in response to request for clarification by the expert from the United Kingdom in informal document No. 27, distributed at the eighty-fifth session of GRSG.

Re. paragraph 7.2.3.2.

Such a requirement would be impracticable in the amount of space required to display the information. In a fully-flexible vehicle, the manufacturer has no way of knowing the configuration(s) which the operator will use.

Re. paragraph 7.5.

It should only be necessary to approve the vehicle once with regard to fire risks. If retention is justifiable, all remaining provisions dealing with all inherent fire risks for all categories of vehicle should be transferred to an expanded Regulation No. 34 and a cross-reference provided.

Re. paragraph 7.6.2.1.

Provision for special types of vehicle currently in use, so as to permit type-approval of such types.

Re. paragraph 7.6.2.3.

Clarification to overcome interpretation problems encountered in practice.

Re. paragraph 7.6.2.4.

Deletion of the word "emergency" in order to allow use of a service door where one exists.

Re. paragraph 7.6.3.2.

Clarification of applicability of requirements of paragraph 7.6.3.1. when applied to Classes A and B.

Re. paragraph 7.6.4.6.

It should only be necessary to approve the vehicle once with regard to vision.

Re. paragraph 7.6.5.4.

It is impossible to cater for certain exceptional lighting effects.

Re. paragraph 7.6.10.7.

This text is highly subjective and impossible to comply with as written. It is bound to give rise to a wide variety of interpretations in practice.

Re. paragraph 7.6.11.1.

Symbolic markings are of more value.

Re. paragraphs 7.7.1.1., 7.7.1.2. and annex 4, figure 1.

Clarification and correction. No change of substance.

Re. paragraph 7.7.1.3.

Clarification.

Re. paragraph 7.7.1.6.

Amended to clarify that the value of 22.5 cm applies to all sideways-facing seats, not just those at wheel arches.

Re. Paragraph 7.7.1.8.

This need to be amended in order to clarify if only one or more are permitted.

Re. paragraphs 7.7.1.12. to 7.7.5.8.

Clarification.

Re. paragraph 7.7.7.2.

Clarification. Consideration should be given to removing the text in square brackets as it adds no value and is covered by other parts of the text.

Re. paragraph 7.7.8.3.

Clarification required following discussions with approval authority.

Re. paragraph 7.7.8.5.1.

Editorial changes to amendment agreed for Regulations Nos. 36, 52 and 107.00 at the eighty-fifth session of GRSG in order to fit into Regulation No. 107.02.

Re. paragraph 7.7.8.5.3.

Correction of cross-reference.

Re. paragraph 7.7.8.6.1.

Clarification based on the Russian proposal (see informal document No. 27 distributed at the eighty-fifth session of GRSG)

Re. paragraph 7.7.8.6.3.2.

Need for clarification following discussion with approval authority.

Re. paragraph 7.7.8.6.3.3.

Some Class II vehicles are based on Class I shells. Also allows common structures for Class A and small Class I vehicles.

Re. paragraph 7.7.9.1.

The text must be approved for the country of destination. Alignment with annex 7.

Re. paragraph 7.8.5.

Incorporate recent approval authority interpretation.

Re. paragraph 7.11.1.4.

This would enable the handrail to curve towards the body at the end, reducing risks of catching clothing and of impact injuries.

Re. paragraph 7.11.2.

Clarification.

Re. paragraph 7.12.1.

Aligns with Regulation No. 52. Where seat belts are fitted, the presence of a rigid guard in a small vehicle could be counter-productive due to impact of limbs, etc. of the restrained passenger on the rigid parts of the guard.

Re. annex 4, figure 1

Figure redrawn to correctly reflect the text.

Re. annex 7

Clarification to align with existing text in annex 3.

Re. annex 7, paragraph 1.1.1.

Correction of cross-reference.

Re. Annex 8,

Re. paragraph 3.11.2.3.

Raising does not present a risk and may happen too quickly for driver intervention.

Re. paragraph 3.11.2.4.

Clarification.

Re. paragraph 3.11.4.3.4.

Clarification.

Re. annex 9, paragraph 1.2.2.

Should be amended to allow 12V and 42V technology.
