

Note by the secretariat: As part of the secretariat's efforts to reduce expenditure, this voluminous informal document No. 9 will not be distributed during the 45th GRPE session. Delegates are kindly requested to bring their copies of this document to the meeting.

Worldwide Harmonised Motorcycle Emissions Certification Procedure



Draft Technical Report

UN/ECE-WP 29 - GRPE

WMTC Working Group

Author: Heinz Steven

RWTÜV Fahrzeug GmbH

Institute for Vehicle Technology

28. December 2002

	Content	Page
1	Introduction	3
2	Objective	3
3	Structure of the Project	4
4	Cycle Development	5
	4.1 Approach	5
	4.2 In-use Driving Behaviour Data	6
	4.3 Fleet Composition and Vehicle Use	9
	4.4 The Reference Database	12
	4.5 Modification of the Draft Test Cycle and Final Version	15
5	Gearshift Procedure Development	19
6	Driveability Tests	24
7	Vehicle Classification	25
8	Weighting Factors for an Overall WMTC Emissions Result	27
9	Emissions Validation Tests	27
	9.1 General Information	27
	9.2 Results of the Emissions Validation Programme	32
10	Test Protocol	41
11	Round Robin Test	41
12	Off Cycle Emissions	41
13	Summary and Conclusions	41
14	Literature	42
	Annex A - Description of the Modification Work on the WMTC Cycle	
	Annex B - Final Cycle Version	
	Annex C - Test Protocol	

Introduction

At its beginning (1999) WMTC was a tripartite project between the Netherlands Ministry of the Environment (VROM), TNO Automotive and the International Motorcycle Manufacturer Association (IMMA). Within this tripartite project VROM looked after the political aspects of generating a worldwide test cycle. TNO Automotive, funded by VROM, did the development work and the technical management of the project. IMMA contributed by the collection of in-use driving behaviour data worldwide.

In a later stage (May 2000) the project was brought under the umbrella of the UN/ECE WP 29. Under the guidance of WP 29, the Group of Experts on Pollution and Energy (GRPE) mandated the ad-hoc group WMTC with the development of a "World-wide Harmonised Motorcycle Emissions Certification/Test Procedure" and to establish it in the framework of the 1998 Agreement on Global Technical Regulations (GTR). Since October 2000 RWTÜV Fahrzeug GmbH joined the WMTC group. RWTÜV Fahrzeug developed a gearshift procedure closely linked to the test cycle. This work was funded by the German Bundesanstalt für Straßenwesen (Bast). Since May 2001 RWTÜV Fahrzeug got the responsibility for the cycle development work, the development of the test protocol and the coordination of the validation programme by order of the Netherlands Ministry of the Environment (VROM) and with support by the German Federal Ministry of Transport, Building and Housing (BMVBW).

The WMTC group was formed by members of the following countries/organisations:

- AECC,
- European Commission,
- Germany,
- IMMA,
- Japan,
- Netherlands,
- Spain,
- Switzerland,
- UK,
- USA

2 Objective

The objective of the research program is to develop a worldwide-harmonised motorcycle emissions test procedure , consisting of:

- a test cycle,
- a gearshift procedure,
- sampling, measurement and analysis procedures (with support from/in collaboration with ISO)

The test procedure needs to be:

- ❑ representative of world-wide on-road vehicle operation,
- ❑ able to provide the highest possible level of efficiency in controlling on-road emissions,
- ❑ corresponding to state-of-the-art testing, sampling & measurement technology,
- ❑ applicable in practice to existing and foreseeable future exhaust emissions abatement technologies,
- ❑ capable of providing a reliable ranking of exhaust emission levels from different engine types,
- ❑ consistent with the development of appropriate emission factors,
- ❑ inclusive of adequate cycle-bypass prevention provisions.

The test procedure has to cover the cycle and the accompanying gearshift procedure for the test bench measurements and the prescription of test bench settings like determination of road load resistance, inertia mass, cooling requirements, exhaust gas sampling procedure and other test bench specifications.

3 Structure of the Project

The development of the cycle and the gearshift procedure belongs to the tasks of the WMTC group; the prescription of test bench settings was developed in working group 17 of ISO TC22 in close liaison with the WMTC group. Table 1 gives an overview of the tasks of the whole project.

In the work schedule of the WMTC group two validation steps were foreseen after the development of test cycle and gearshift procedure. A first step, in which the driveability was evaluated and a second step, in which the emissions measurement results were evaluated and compared with results from existing certification procedures. The development work and the two validation steps are finished. Finally a round robin test is foreseen starting in Spring 2003.

Step	Task	Status	Responsibility	
1a	collection of statistics about stock and vehicle use	completed	WMTC Subgroup FE	
1b	remonitoring of statistics about vehicle stock and use	completed		
1c	collection and analysis of in-use driving behaviour data	completed		
2a	cycle development	completed		
2b	gearshift prescription development			
3a	driveability	completed		
3b	update of measurement procedure	completed		
3c	emissions validation tests	completed		
3d	analysis of emissions results	completed		
3e	classification			
3f	weighting factors			
4a	road load resistance	completed		ISO TC 22, SC 22, WG 17
4b	def. of inertia mass	completed		
4c	cooling requirements	completed		
4d	exhaust gas sampling procedure	completed		
5	Final measurement procedure (test protocol including cycle, gearshift prescr., add. Specifications)	completed	WMTC Subgroup FE	
6	off cycle emissions provisions			
7a	preparation of round robin test			
7b	round robin test			
7c	analysis of results			
8	Test procedure, Proposal for GTR incl. Off cycle emissions provisions)			

Table 1: The Structure of the whole project

4 Cycle Development

4.1 Approach

The basis of the cycle development was the collection and analysis of driving behaviour data and statistical information about motorcycle use for the different regions of the world. These data had to include all relevant real life vehicle operations and built the basis for the cycle development. In a second step the in-use driving behaviour data were combined with the statistics on vehicle use in order to create a reference database that is representative for worldwide motorcycle driving behaviour. This was achieved using a classification matrix for the most important influencing parameters. In the final classification matrix three different regions (Europe, Japan, USA), three different vehicle classes and three different road categories were included.

The next step was to compact this reference cycle into a test cycle of the desired length. A computer search programme then selects a number of modules (speed/time sequences between two stops) to represent by approximation this length. The statistical characteristics of this number of modules are then compared to those of the database. The comparison is done on the basis of the chi-squared method, an accepted statistical criterion.

Finally a first draft of the World-wide Motorcycle Test Cycle (WMTC) was produced. It was foreseen that this first draft needed to be modified on the basis of an evaluation concerning driveability and practical points concerning the measurement procedure. Since this process is iterative by nature, several adaptation rounds including the driveability tests were carried out.

A flow chart of the development process is shown in Figure 1.

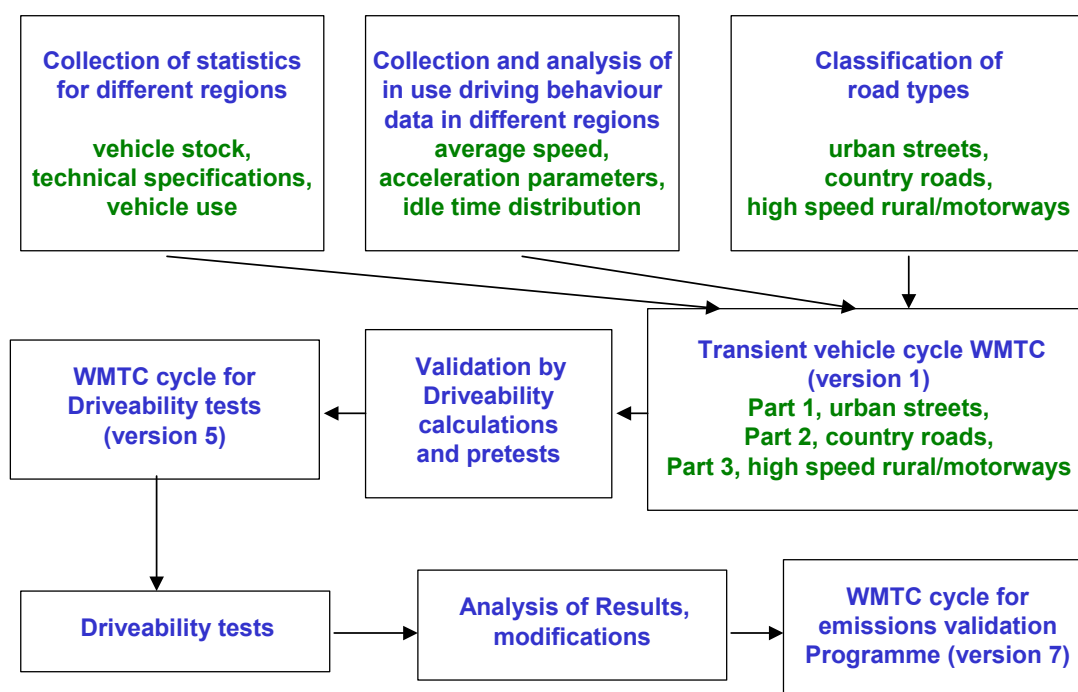

Figure 1: Flow chart of the cycle development work

4.2 In-use Driving Behaviour Data

The basis of the cycle development was the collection and analysis of driving behaviour data and statistical information about motorcycle use for the different regions of the world. These data had to include all relevant real life vehicle operations and built the basis for the cycle development. In a second step the in-use driving behaviour data were combined with the statistics on vehicle use in order to create a reference database that is representative for worldwide motorcycle driving behaviour. This was achieved using a classification matrix for the most important influencing parameters. In the final classification matrix three different regions, three different vehicle classes and three different road categories were included.

The in use driving behaviour data used for the WMTC project consist of the following sub-sets:

- Data measured in Europe
 - 1994, ACEM-group. The measurements were carried out in Paris and Pisa,
 - 1994, JAMA-group. The measurements were carried out in Amsterdam and Frankfurt.

- 1999, ACEM. The measurements were carried out in the area around Pisa (Italy), the area around Mandeure (France) and the area around Munich (Germany).
- Technische Fachhochschule Biel in Switzerland, in and around Biel.
- Technical University of Darmstadt (Germany), around Darmstadt.
- Data measured in Japan
 - 1992, JMOE project. The measurements were carried out in the Tokyo area.
 - 1997, JAMA project. The measurements were carried out in the Tokyo area.
 - 2000, JAMA/JARI project. The measurements were carried out in the Tokyo area including highway. The data is only used for the gearshift model.
- Data measured in China
 - In the Ji Nan area by the Tianjin Motorcycle Technical Center of the Tianjin Internal Combustion Engine Research Institute, belonging to the Tianjin University in China.
- Data measured in the USA
 - 1999, USMMA run, The measurements were carried out in Birmingham, Alabama.

The time duration and the total mileage of these in-use data subsets are shown in Table 2. Table 3 gives an overview about the vehicle sample.

Dataset	Total time (hours)	Total distance (km)
ACEM 1999, Europe	175	9940
Biel data, Switzerland	17	590
Darmstadt data, Germany	109	6370
JMOE 1992, Japan	17	398
JAMA 1997, Japan	14	306
JAMA/JARI 2000, Japan	29	1185
China	7	190
USMMA 1999, USA	150	8245
TOTAL	518	27224

Table 2: Duration and mileage of the in-use data subsets

Region	Dataset	Vehicles		Capacity in cm ³	Rated power in kW	power to mass ratio in kW/t
Europe	IMMA 1994, ACEM-group	Piaggio	80	80	≈ 6	≈ 30
		Cagiva	125	125	≈ 11	≈ 55
		Triumph	Trident 900	885	70	245
		Ducati	916	916	80	295
		BMW	R 1100 RS	1085	66	225
		Harley Davidson	FLST	1340	67	105
	IMMA 1994, JAMA-group	Peugeot	SX 80	73	≈ 7	≈ 45
		Yamaha	DT 125	124	≈ 9	≈ 50
		Suzuki	DR 350 S	349	22	105
		Kawasaki	GDZ 500 S	498	25	100
IMMA 1999	Honda	Transalp	583	37	137	
	Peugeot	Elyseo	100	6.4	35	
	Piaggio	Liberty	125	7.3	40	
	Aprilia	Classic	125	11	47	
	Piaggio	Vespa ET 4	150	8.4	44	
	Yamaha	XV 535 S	535	35	130	
	BMW	R 850 R	850	52	164	
Honda	CBR 1100 XX	1100	110	335		
Harley Davidson	Electraglide	1450	49	117		
Biel data	Honda	CB 450 S	450	≈ 38	≈ 150	
Darmstadt data	Honda	CB 500 (25 kW)	500	25	93	
	Suzuki	GSX R600	600	72	263	
	BMW	GSX-R 600	600	57	179	
Japan	JMOE 1992	Japan A	Scooter	49	5	36
		Japan B	Scooter	99	6.6	42
		Japan C		249	21	102
		Japan D		399	34	125
	JAMA 1997	Yamaha	Scooter	49	5	35
		Honda	CB 400	399	39	146
JAMA/JARI 2000	Japan 1		399	39	139	
	Japan 2		599	57	187	
	Japan 3		998	68	197	
China	Tianjin Motorcycle Technical Centre	Qingqi (Suzuki)	QS 125	125	7.3	38
USA	IMMA 1999	Piaggio	Typhoon	125		
		Kymco		125		
		KTM	LXC 400	400	39	172
		Yamaha	Virago	535	34	124
		BMW	R 1100 RS	1085	67	224
		Harley Davidson	FLHCT	1300	41	96
Honda	Valkyrie	1500	75	181		

Table 3: The vehicle sample of the in-use driving behaviour database

4.3 Fleet Composition and Vehicle Use

The content of this chapter is adopted from [1]

Vehicle Stock

From the industrial partners statistical data have been received as to the respective local vehicle fleets in different regions of the world. One should bear in mind, however, that the available data are not very 'hard'. One obvious problem with statistics from widely different sources is that usually they are not coherent. It has been attempted to limit the data to motorcycles of more than 50 cc, although it is not always clear whether the available statistics include or exclude the class below 50 cc. From an evaluation of the statistical data received, sufficient conclusions can nevertheless be derived as to the composition of the vehicle fleet in different regions of the world.

- Europe has a fleet that mainly consists of either small capacity vehicles, mainly scooters, on the one hand, and of large sports and touring bikes on the other, with few vehicles in between. The distribution is very country dependant. Generally speaking northern countries possess a large percentage of big bikes, whereas southern countries tend to have mainly small vehicles.
- Japan has a similar share of small vehicles as Europe, but has a more or less equal number in the middle category. Really big bikes are rare in Japan.
- The USA has mainly big bikes (most of them really big) and very few in the small and middle categories.

The situation is shown in Figure 2.

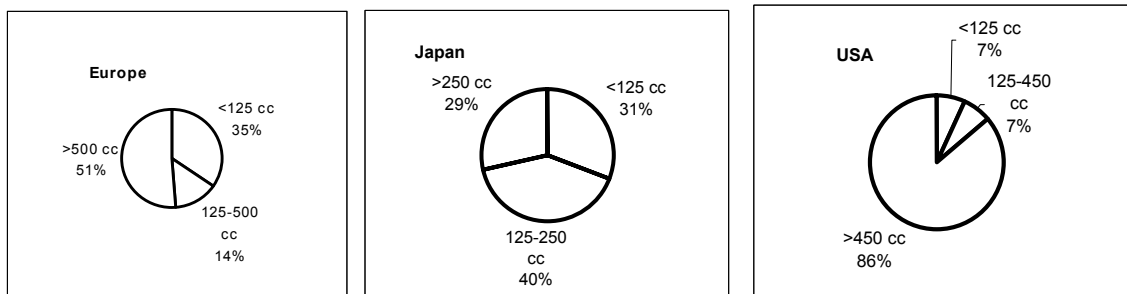

Figure 2: The composition of the fleet in Europe Japan and the USA in 1997. Note that the subdivision is not equivalent for all three regions, due to the structure of the available data. (from [1])

The total fleet size for Europe (that is including non-EU members Switzerland and Norway), Japan and USA and the total annual mileage are shown in the following figure.

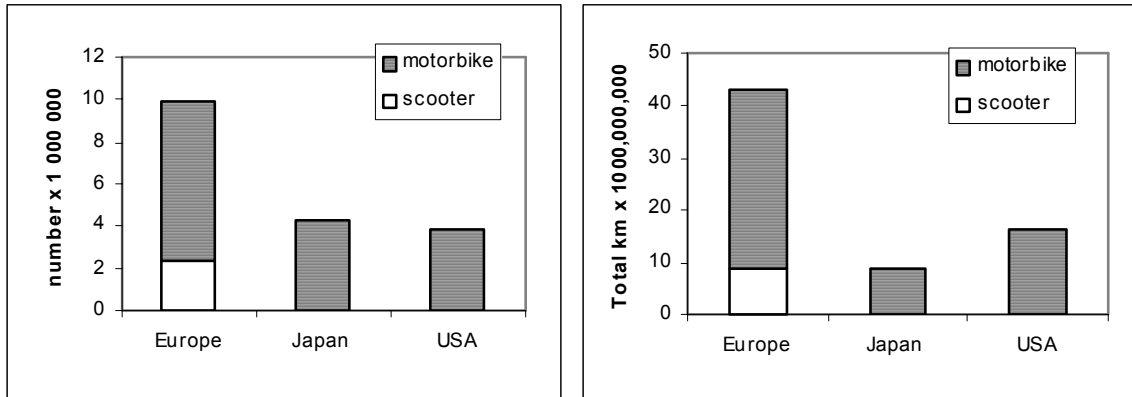

Figure 3: The total fleet size in the three regions, numbers of vehicles (left) and total annual mileage (right), (from [1])

For Japan and the USA no figures about scooters are available.

Vehicle Use

One obvious problem when comparing the use on different road types in different parts of the world, is that the definitions, and often even the road types themselves, do not compare on a 1:1 basis. So any comparison can only be approximate. The following information was supplied by the IMMA members.

The characteristic use in Europe depends heavily on the class and the country. According to a user's survey by a major scooter manufacturer the small machines (mainly scooters) are almost exclusively used in an urban environment. The average trip length is small. This is the main pattern in south-European countries. According to a survey by the TU Darmstadt [2] the big machines are mainly used for recreational trips. The average trip length is large. This use is mainly on country roads, because the users are enthusiasts that like a challenging route. This agrees with available information from the Netherlands and it seems to be the dominant use in north-European countries.

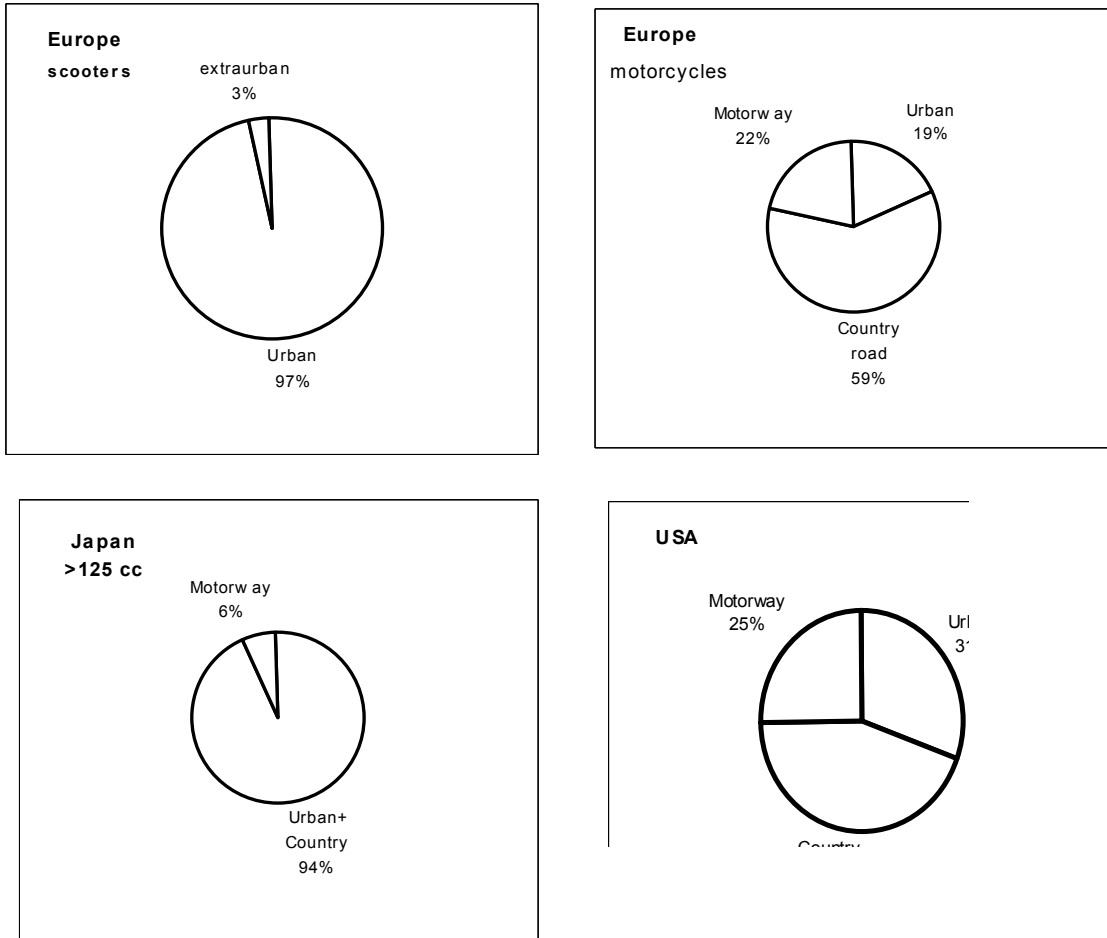

Figure 4: Characteristic use per type of road (from [1], but corrected for US data)

The information that is available about Japan suggests that the majority of the mileage is performed on secondary roads, including urban roads. The maximum speed on country roads is 60 km/h. On motorways since October 2000 the posted speed is 100 km/h; before that date it was 80 km/h. Vehicles below 125 cc are not allowed on motorways, but even for bigger bikes the motorway share is small. Commuting and shopping are important motives in Japan. For the class < 125 cc 'business' is an important motive as well (26 %), whereas for the classes above 125 cc recreational use is an important motive (34 % for the class 125-250 cc, and 49 % for the class >250 cc). The total annual mileages are low, suggesting small average trip lengths and low average speeds.

In the USA there is a larger share of urban use than in Europe and a smaller share of country roads. The use of motorways is roughly equal to that in Northern Europe. The annual mileages are relatively low and so are, presumably, the trip lengths.

Annual mileages are difficult to obtain, but the following table gives some indications.

Class	Region	Annual mileage
Engine capacity < 150 cm ³	Europe	2500 – 5000 km
	Japan	Approx. 1400 km
	USA	3000 – 3500 km
Engine capacity 150 – 450 cm ³	Europe	Approx. 3500 km
	Japan	Approx. 2300 km
	USA	3750 – 4250 km
Engine capacity > 450 cm ³	Europe	Approx. 5000 km
	Japan	Approx. 2400 km
	USA	5000 – 5500 km

Table 4: Approximate annual mileages per capacity class and region (from [1], but corrected for US data)

4.4 The Reference Database

It was originally planned to create the reference database by combining the in-use driving behaviour data with the statistics on vehicle use (see Figure 5). This should be done using a classification matrix for the most important influencing parameters. In the classification matrix three different regions, three different vehicle classes and three different road categories should be included.

The reference database would then have been a combination of representative in-use data expressed in terms of vehicle speed for each cell of the classification matrix and with the corresponding weighting factors.

But since the data about vehicle use were not reliable enough and since the WMTC group could not find a compromise for the vehicle classification the following alternative approach was chosen:

The cycle should be designed as consisting of three parts, each part representing a separate road category. Part 1 should be a low speed part, mainly representative for urban traffic; part 2 should be a medium speed part and represent slower country road type of traffic, and part 3 should be a high-speed part and represent faster country roads and motorways. Part 1 should incorporate a cold start.

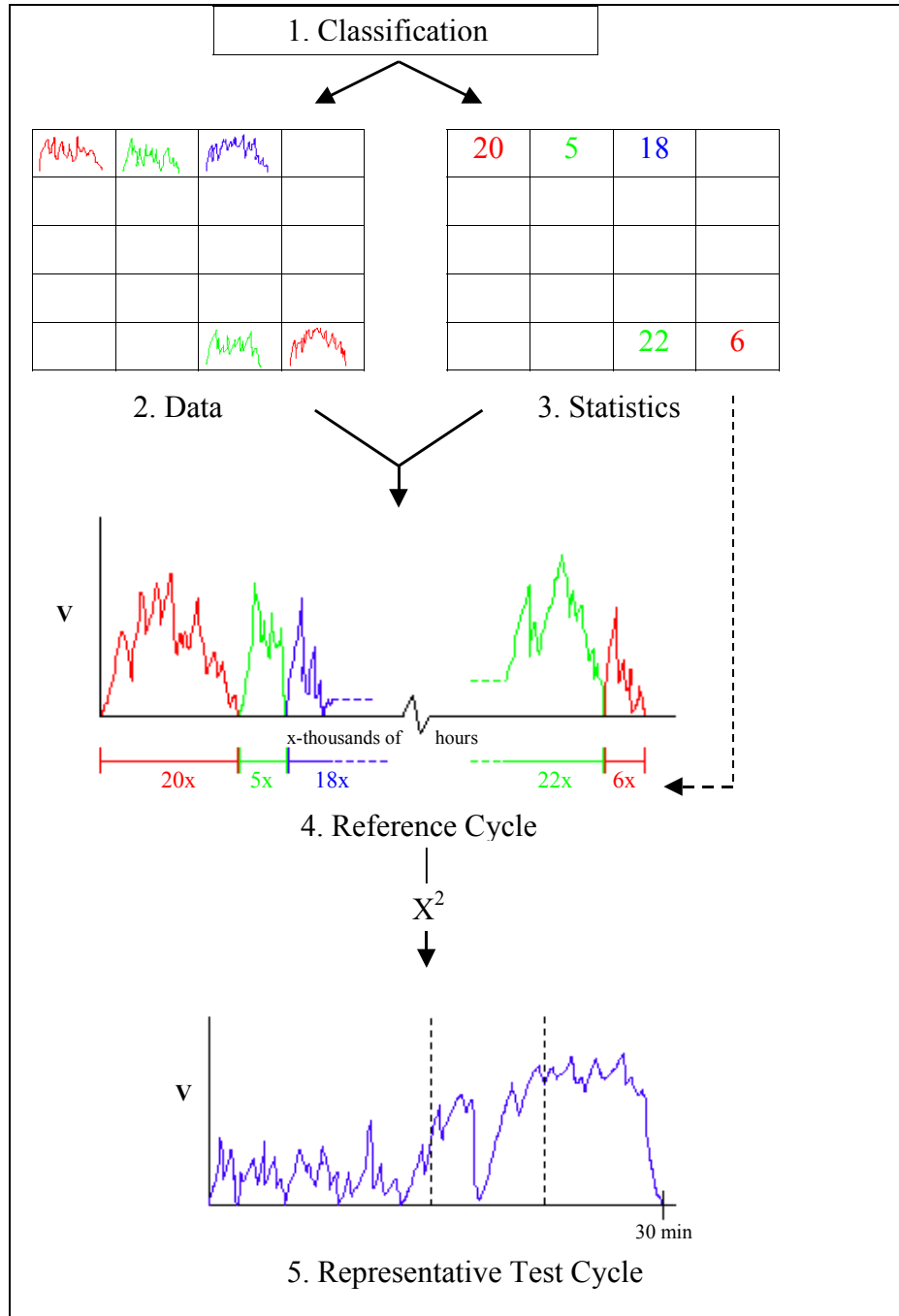

Figure 5 Flowchart for the construction of a test cycle out of a large randomly distributed database, from [1].

By measuring the emissions separately for each part, this approach allows to perform validation tests with a provisional vehicle classification and take into account vehicle use statistics by applying weightings to the results for each part. Consequently the in-use data were separated into 3 classes corresponding to the above mentioned 3 road categories.

Since information of road categories was not available for all in-use data and since the classification may vary from region to region, it was attempted to characterise the road categories, for a vehicle for which these categories were known, on the basis of the length of vehicle speed modules and the average speed of these modules. A module is a speed sequence between two stops. This was not very successful, partly because of the routes chosen. A second attempt on the basis of average speed and maximum speed per module looked more promising. There was a reasonable distinction between the road categories. The main overlap was between fast country and motorway traffic, but this was acceptable, as both categories should build one single class.

Eventually an approach was chosen that characterises the modules on the basis of speed distribution. This approach was used earlier for a similar problem in characterising the road use of hybrid driven passenger cars. To this end for every module the share of speeds was calculated below 60 km/h, between 60 and 90 km/h and above 90 km/h. Subsequently the following allocation was used:

Allocation of driving types	
Part 1	0-60 km/h \geq 80%
	90+ km/h = 0%
	Vmax \leq 80 km/h
	additionally: length of sequence \geq 1m
Part 2	0-60 km/h \leq 70%
	60-90 km/h \geq 30 %
	90+ km/h \leq 50 %
	Vmax \leq 110 km/h
Part 3	0-60 km/h \leq 20 %
	90+ km/h \geq 50 %

Table 5: Allocation of driving types for the three cycle parts

This approach was selected as a pragmatic solution to the problem. The additional requirement of Part 1 was included to prevent ‘creeping’ from being selected as a representative driving mode. Subsequently this way of allocation was applied to all data.

The second step then was to compact these reference cycles into test cycle parts of the desired length in time, which was set to 600 s for each part. A computer search programme was developed by TNO that selected a number of modules (speed/time sequences between two stops) to represent by approximation this length. The statistical characteristics of this number of modules were then compared to those of the corresponding database.

The comparison was done on the basis of the chi-squared method for the acceleration versus speed matrix (v*a-matrix). The selection of modules with the lowest value for chi-squared was then selected as the ideal combination. So first the ideal lengths of the various modules were determined, and then the most representative modules corresponding with those lengths were selected. After the module selection the stops were added. The total stop time was taken from statistics. This total stop time was then divided into stops on the basis of the

statistical distribution of the stop lengths in the in-use database. Finally a first draft of the World-wide Motorcycle Test Cycle (WMTC) was produced.

4.5 Modification of the Draft Test Cycle and Final Version

It was foreseen that the first draft needed to be modified on the basis of an evaluation concerning driveability and practical points concerning the measurement procedure. Since this process is iterative by nature, several adaptation rounds including the first step of the validation programme were carried out.

The following modifications were made during the validation phase and the driveability tests:

- Deletion of an ultra short module with operational speeds below 20 km/h in part 1,
- Separation of an extremely long module in part 1 into 3 parts that were more representative for urban driving,
- Replacement of 3 part 1 modules by more representative modules,
- Correction of the idle time distribution for part 1,
- Rearrangement of the rank order of the modules in part 1 with respect to cold start requirements,
- Smoothing of ripples in the quasi constant cycle phases of parts 2 and 3 to delete unrealistic fluctuations in the speed signal caused by the speed measurement uncertainty,
- The maximum speed of part 3 was set to 125 km/h,
- The acceleration time pattern was smoothed in order to delete unrealistic high changes of the acceleration rate that could cause driveability problems like tyre slip,
- The highest deceleration values were reduced to take into account that only the drive wheel brake is working on the roller bench.
- To reduce the risk for tyre slip the da/dt values were limited to $-0.8 \text{ m/s}^2/\text{s} \leq da/dt \leq +0.8 \text{ m/s}^2/\text{s}$. Consequently the vehicle speed pattern were modified until da/dt falls into that range.
- A special part 1 cycle, called "part 1, 50 cc" was created for low powered motorcycles, whose technical specifications are close to mopeds, by limiting the top speed of part 1 to 50 km/h and limiting the acceleration/deceleration values to $+2/-2 \text{ m/s}^2$.

Although version 7 of the WMTC cycle was based on a smoothed acceleration pattern to avoid excessive changes in acceleration over time, the question of tyre slip was raised again at the WMTC meetings in Madrid (17.12.2001) and Geneva (16.1.2002). Consequently an additional analysis of this problem was executed. This analysis was based on the results of 4 vehicles (2 from the US and 2 from Japan), for which second by second data of roller speed as well as tyre speed had been delivered for the WMTC as well as for the US FTP and TRIAS/ECE R 40. The latter was only measured in Japan. The Japanese vehicles belong to Pclass 1 and 2, the US vehicles to Pclass 3 (see chapter 9). The word "Pclass" stands for the provisional classification used for the emissions validation tests (see chapter 7).

The tyre slip was calculated as difference between tyre speed and roller speed divided by the roller speed and expressed in %. That means tyre slip gives positive values, tyre lock negative values. In addition the change of acceleration rate per second was calculated for the acceleration values of the set speed.

The majority of tyre slip values $\geq 50\%$ occurred during the transition from standstill to driving, surprisingly not only for the WMTC but also for the US FTP and the TRIAS/ECE R 40. The analysis results show that the dynamics of the WMTC do not cause higher risks for tyre slip than existing certification cycles. As already concluded from interim results and the analysis of the answers to the questionnaire about the tyre slip, the problem is related to individual tyre/roller combinations (see chapter 6). Nevertheless it was decided in the WMTC group that the tyre slip risk should be minimised for the WMTC by limiting the change of acceleration rate in order to improve driveability, independent of the situation for existing cycles.

During the WMTC FE meeting in Tokyo in April 2002 the Japanese delegation proposed to create a special version of part 1 with a top speed of 50 km/h for low powered motorcycles whose technical specifications are close to mopeds. Since there is only one module in part 1 with vehicle speeds above 50 km/h (module 3), only this module was modified. The first part was replaced by a module taken from in-use measurements of vehicle 6 (this module was closest to the existing one) and the second part was lowered in speed to fulfil the limitation of 50 km/h.

All modifications done in the adaptation rounds are described in detail in **Annex A - Description of the Modification Work on the WMTC Cycle**. Tables containing version 8 are shown in **Annex B – Final Cycle Version**.

The final result that will be used for the round robin test starting in Spring 2003 is shown in Figure 6 to 9. Each part is 600 s long. Part 1 representing urban driving consists of 8 modules interrupted by standstill at idling. The top speed is 60 km/h. Part 2 representing driving on secondary rural roads consists of 2 modules, the top speed is 95 km/h. Part 3 representing primary rural roads and motorways consists of 1 module, the top speed is 125 km/h.

The characteristics of the WMTC driving cycle(s) are shown in Table 6 and Table 7. The definitions for the driving modes are given in Table 8.

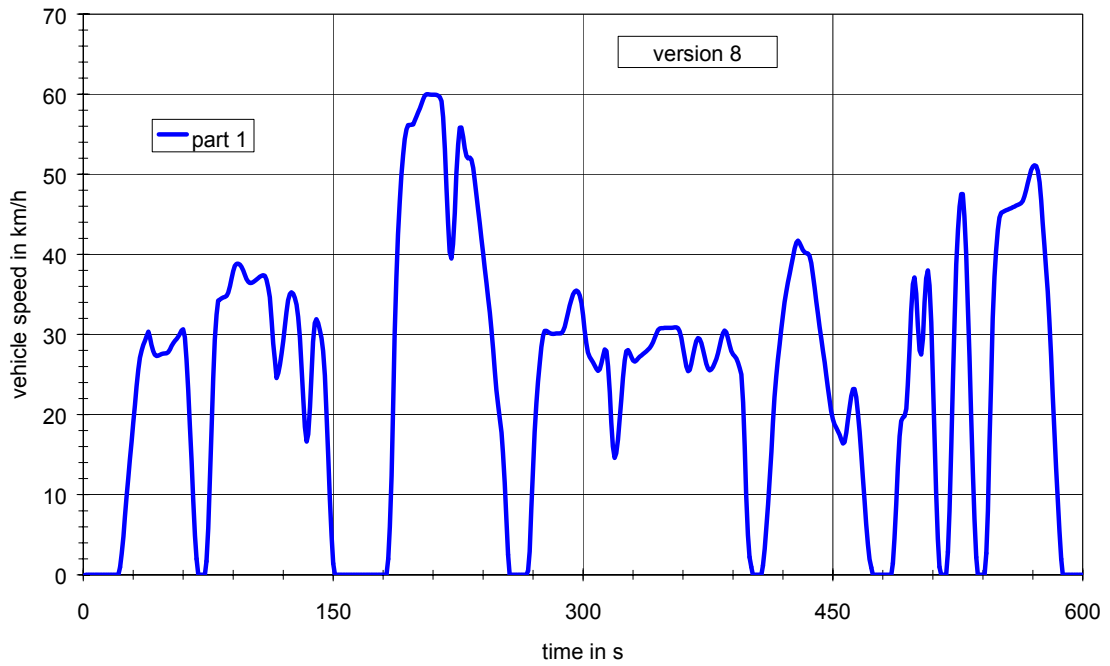

Figure 6: WMTC driving cycle, part 1

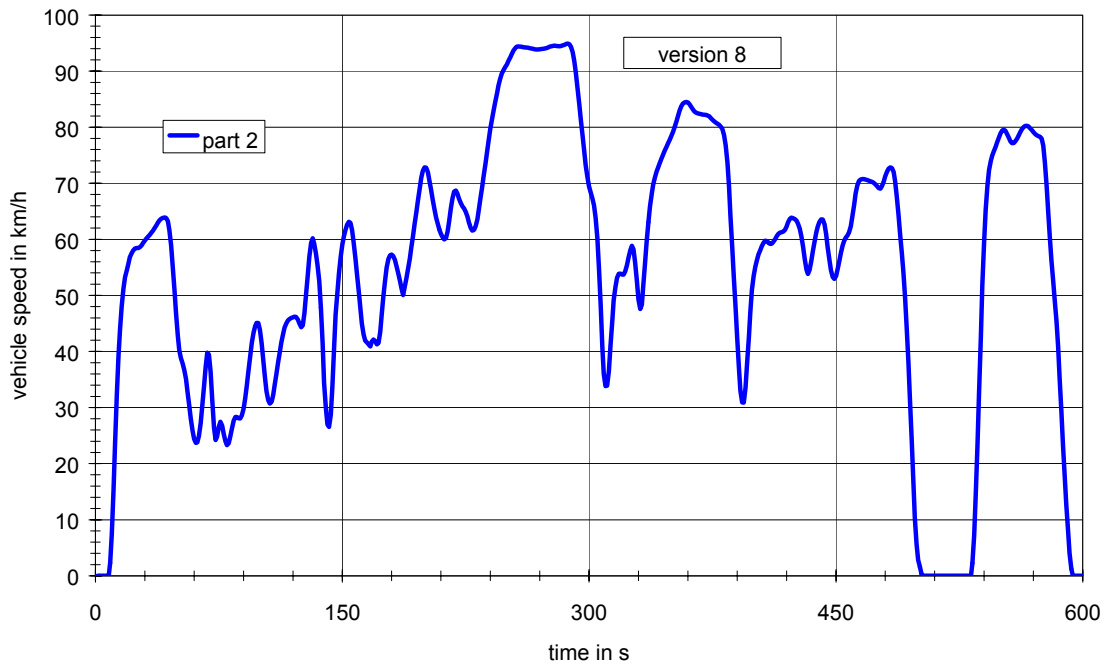

Figure 7: WMTC driving cycle, part 2

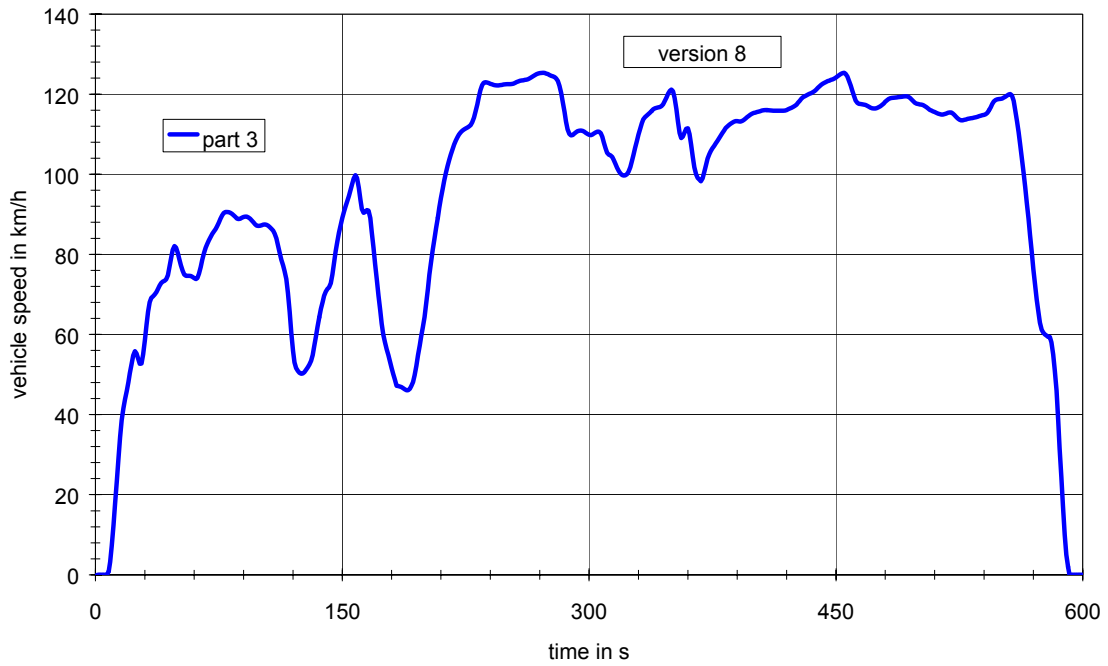

Figure 8: WMTC driving cycle, part 3

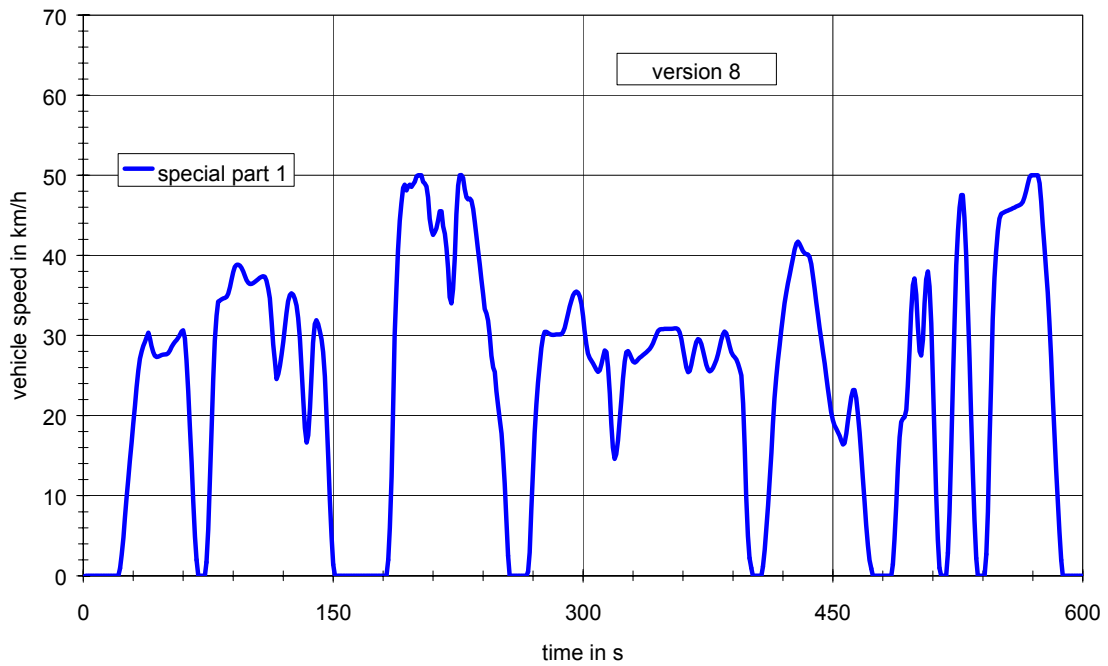

Figure 9: WMTC driving cycle, part 1, reduced speed, for low powered motorcycles whose technical specifications are close to mopeds

WMTC cycle (ver. 8)	Time s	Distance km	Average speed km/h	Max. speed km/h	Max. acceleration m/s ²	Max. deceleration m/s ²
part 1	600	4.07	24.4	60.0	2.51	2.00
part 2	600	9.11	54.7	94.9	2.68	2.02
part 3	600	15.74	94.4	125.3	1.56	2.00
part 1 special (ver. 8.2)	600	3.94	23.6	50.0	2.00	2.00

Table 6: Characteristics of WMTC driving cycle (1)

WMTC cycle (ver. 8)	Idle time ratio %	Acceleration time ratio %	Deceleration time ratio %	Cruise time ratio %	Ave. acceleration (acceleration mode) m/s ²	Ave. deceleration (deceleration mode) m/s ²	Ave. cruise speed (cruise mode) km/h
part 1	17.0	28.3	28.2	26.5	0.685	0.693	35.3
part 2	7.3	35.5	28.3	28.8	0.582	0.733	70.4
part 3	2.5	25.7	18.5	53.3	0.468	0.677	108.6
part 1 special (ver. 8.2)	17.0	27.3	28.7	27.0	0.696	0.668	34.6

Table 7: Characteristics of WMTC driving cycle (2)

4 modes	Definition
idle mode	vehicle speed < 5km/h <u>and</u> -0.5 km/h/s (-0.139 m/s ²) < acceleration < 0.5 km/h/s (0.139 m/s ²)
acceleration mode	acceleration >= 0.5 km/h/s (0.139 m/s ²)
deceleration mode	acceleration =< 0.5 km/h/s (0.139 m/s ²)
cruise mode	vehicle speed >= 5km/h <u>and</u> -0.5 km/h/s (-0.139 m/s ²) < acceleration < 0.5 km/h/s (0.139 m/s ²)

Table 8: Definition of driving modes

5 Gearshift Procedure Development

The development of the gearshift procedure was based on an analysis of the gearshift points in the in-use data. In order to get generalised relations between technical specifications of the vehicles and gearshift speeds the engine speeds were normalised to the utilisable band between rated speed and idling speed.

In a second step the end speeds (vehicle speed as well as normalised engine speed) for up-shifts and downshifts were determined and collected in a separate table. The averages of these speeds for each gear and vehicle were calculated and correlated with technical specifications of the vehicles.

A flow chart of the development procedure is shown in Figure 10.

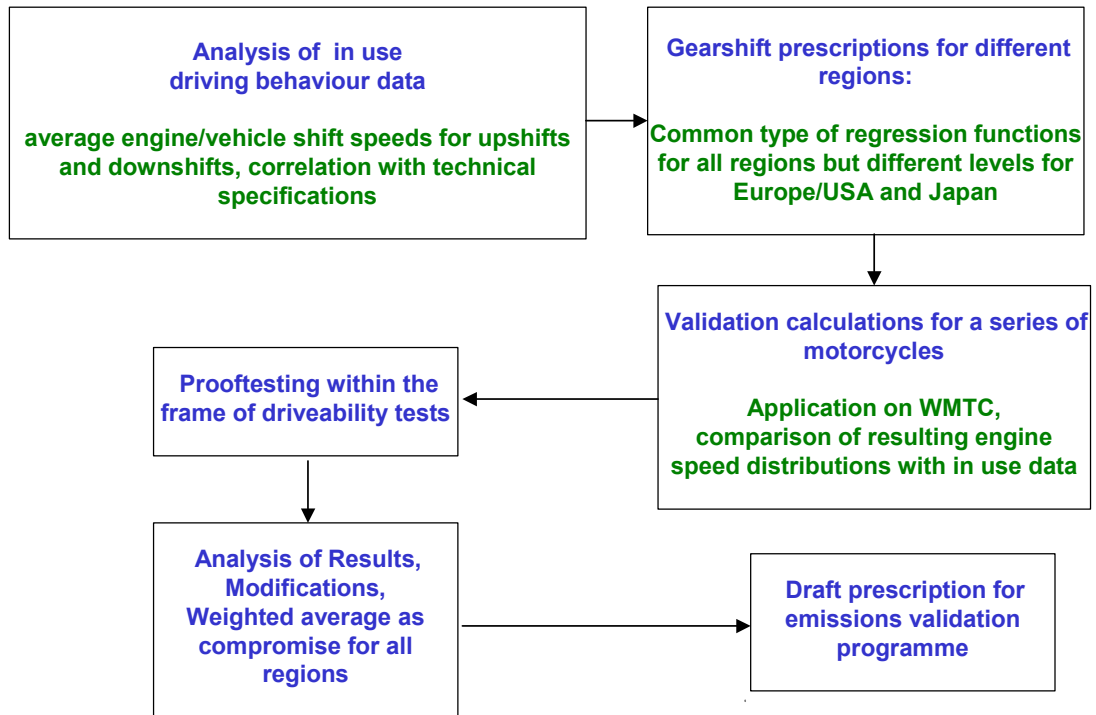

Figure 10: Flow chart of the gearshift prescription development

The results of these analyses and calculations can be summarised as follows:

- The gearshift behaviour is engine speed related rather than vehicle speed related.
- The best correlation between gearshift speeds and technical data was found for normalised engine speeds and the power to mass ratio (rated power/(kerb mass + 75 kg), see Figure 11.
- The residual variations cannot be explained by other technical data or by different transmission ratios. They are most probably assigned to differences in traffic conditions and individual driver behaviour.
- The best approximation between gearshift speeds and power to mass ratio was found for exponential functions, see Figure 11.
- The gearshift function for the first gear is significantly lower than for all other gears.
- The gearshift speeds for all other gears can be approximated by one common function.
- No differences were found between 5speed and 6speed gearboxes.
- The gearshift behaviour in Japan is significantly different from the equal-type gearshift behaviour in Europe and in USA, see Figure 11.

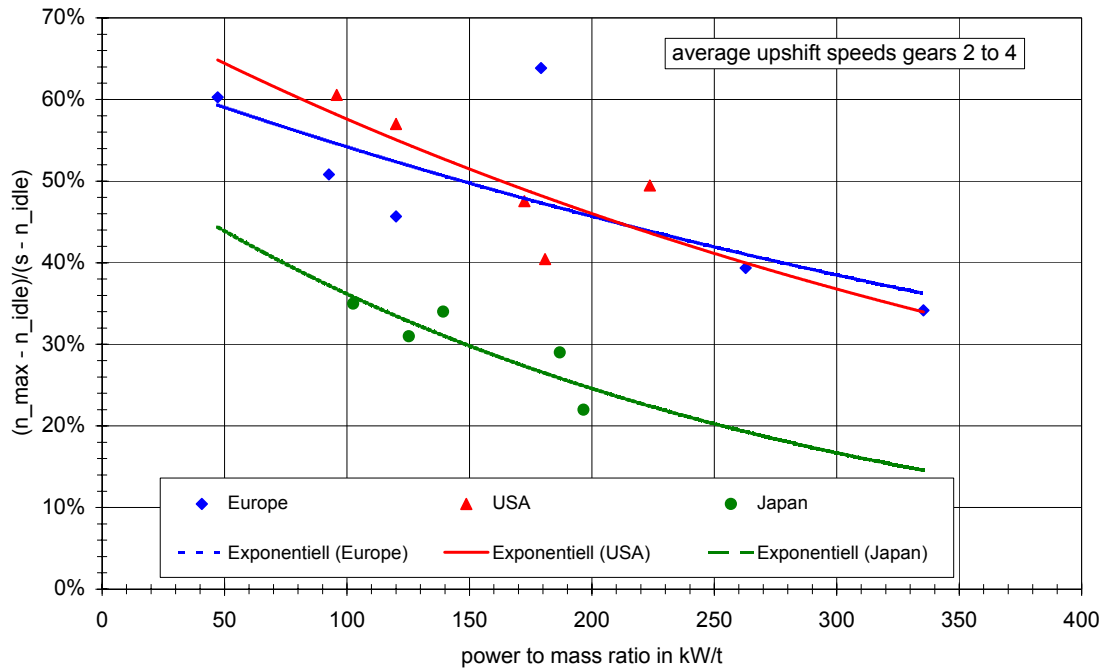

Figure 11: Correlation between normalised max engine speeds for upshifts and power to mass ratio

In order to find a balanced compromise between the three regions a new approximation function for normalised upshift speeds vs. power to mass ratio was calculated as weighted average of the EU/US curve (with 2/3 weighting) and the Japanese curve (with 1/3 weighting), see Figure 12. Based on this, the gearshift prescriptions can be summarised as follows:

Max. engine speeds during acceleration phases:

1. gear: $n_{norm_max} = 0,5753 \cdot \exp(-0,0019 \cdot pmr) - 0,10$ **Equation 1**

all other gears: $n_{norm_max} = 0,5753 \cdot \exp(-0,0019 \cdot pmr)$ **Equation 2**

explanations:

$pmr = Pn / (m0 + 75 \text{ kg})$ in kW/t

$n_{norm} = (n - n_{idle}) / (s - n_{idle})$

Pmr – power to mass ratio

Pn – rated power

m0 – kerb mass

n – engine speed, n_{idle} – idling speed, s – rated speed

Min. engine speeds during acceleration phases:

$$n_{norm_min_acc}(i) = n_{norm_max}(i-1) \cdot r(i) / r(i-1) \quad \text{Equation 3}$$

$r(i)$ – gear ratio or ratio between engine speed and vehicle speed in gear i

Min. engine speed for deceleration or cruising phases:

$$n_{norm_min_dec}(i) = n_{norm_min_acc}(i-1) \cdot r(i) / r(i-1) \quad \text{Equation 4}$$

r(i) – gear ratio or ratio between engine speed and vehicle speed in gear i

Additional specifications:

- The equations above define lower limits for the engine speed. The resulting engine speed values can be rounded to multiples of 100 min⁻¹ for practical applications. Higher shift speeds are permitted in any cycle phase in order to improve the driveability or in order to reduce the amount of test bench measurements for a vehicle family,
- No gearshift if a deceleration phase follows immediately after an acceleration phase,
- No downshift to 1. gear during deceleration down to standstill,
- Minimum time span for a gear sequence: 2 seconds,
- Clutch disengaged, if v < 10 km/h.

To give the test engineer more flexibility and to assure driveability the gearshift regression functions should be treated as lower limits. Higher shift speeds are permitted in any cycle phase.

These prescriptions were used in the emissions validation programme. The definitions for acceleration, deceleration and cruising phases are given in Table 8. Figure 13 shows an example for a gearshift sketch for a small vehicle. The solid lines demonstrate the gear use for acceleration phases; the dotted lines show the downshift points for deceleration phases. During cruising phases the whole speed range between downshift speed and upshift speed may be used. In order to avoid driveability problems this instruction had to be supplemented by additional requirements some of them are general, some are assigned to particular cycle phases.

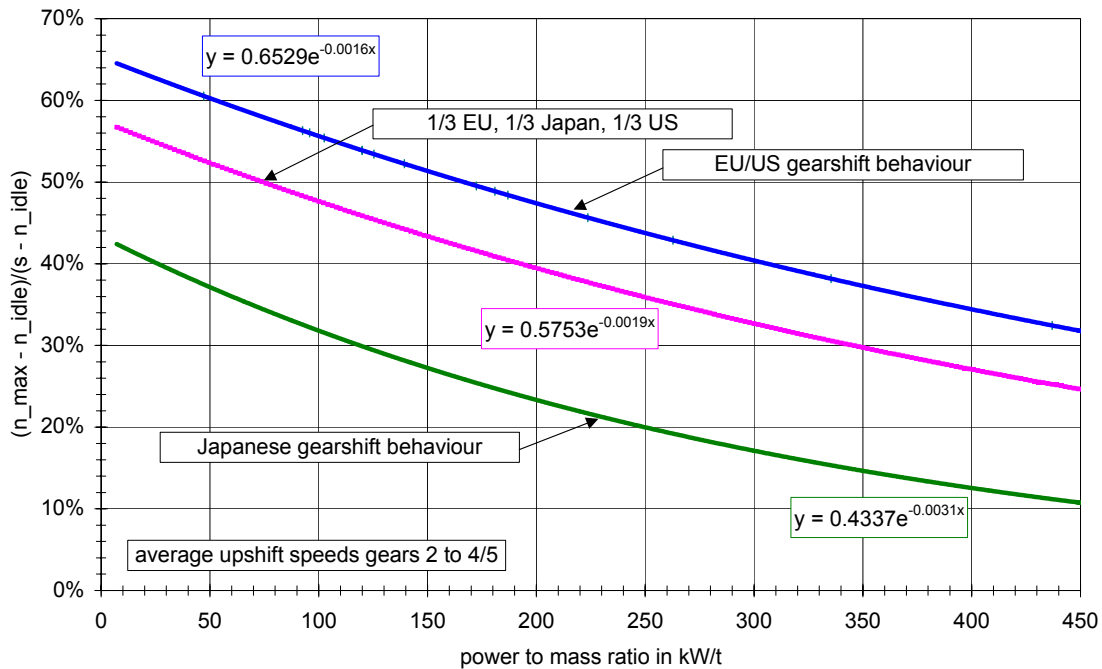

Figure 12: The final approximation function for upshift speeds in gears higher than 1 (1/3 EU, 1/3 Japan, 1/3 US)

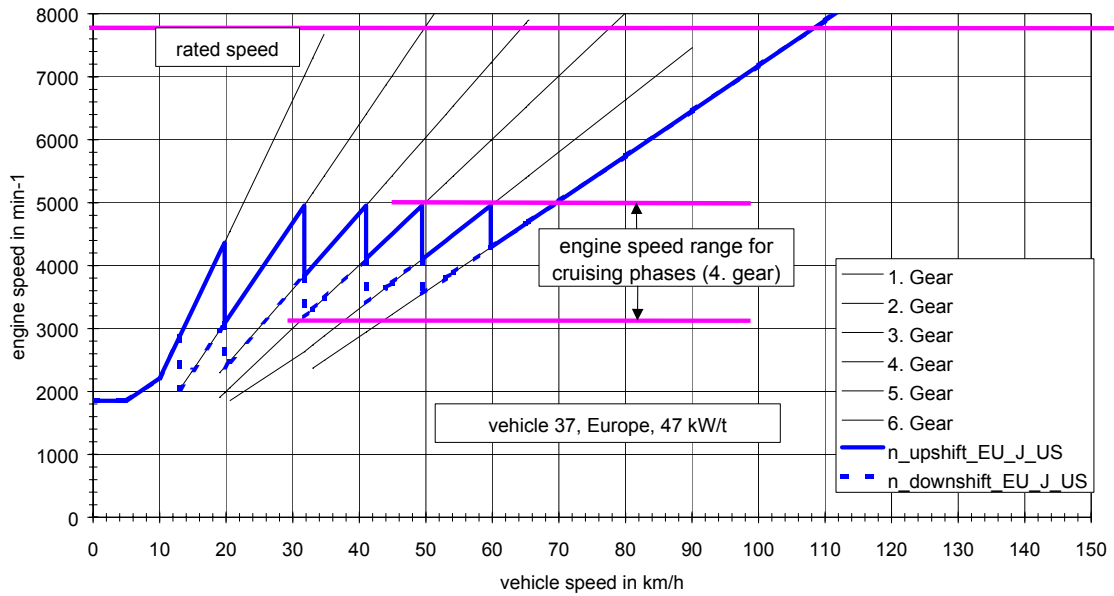

Figure 13: Example of a gearshift sketch for a small vehicle

Calculation example:

An example of input data necessary for the calculation of shift speeds is shown in Table 9. The upshift speeds for acceleration phases for the 1. gear and higher gears are calculated with equations 1 and 2. The denormalisation of engine speeds can be executed by using the equation $n = n_{norm} * (s - n_{idle}) + n_{idle}$.

The downshift speeds for deceleration phases can be calculated with equation 4. The n/v values in Table 10 can be used as gear ratios. These values can also be used to calculate the affiliated vehicle speeds (vehicle shift speed in gear $i = \text{engine shift speed in gear } i / n/v_i$). The corresponding results are shown in Table 10 and Table 11.

cap in cm ³	600
Pn in kW	72
m0 in kg	199
s in min-1	11800
n_idle in min-1	1150
n/v 1	133.66
n/v 2	94.91
n/v 3	76.16
n/v 4	65.69
n/v 5	58.85
n/v 6	54.04
pmr in kW/t	262.8

Table 9: Input data for the calculation of engine and vehicle shift speeds

	EU/US/Japan driving beh.	
	n_acc_max 1	n_acc_max i
n_norm	24.9%	34.9%
n_in_min-1	3804	4869

Table 10: Shift speeds for acceleration phases for the 1. gear and for higher gears (according to Table 9)

	EU/US/Japan driving beh.		
upshifts	v in km/h	n_norm_i	n_i in min-1
1->2	28.5	24.9%	3804
2->3	51.3	34.9%	4869
3->4	63.9	34.9%	4869
4->5	74.1	34.9%	4869
5->6	82.7	34.9%	4869
downshifts			
2 -> cl	15.5	3.0%	1470
3 -> 2	28.5	9.6%	2167
4 -> 3	51.3	20.8%	3370
5 -> 4	63.9	24.5%	3762
6 -> 5	74.1	26.8%	4005

Table 11: Engine and vehicle shift speeds according to Table 10

In a further step the possibility of a simplification of the above-described gearshift algorithms was examined by additional analyses and calculations. It should especially be checked whether engine shift speeds could be replaced by vehicle shift speeds. The analysis showed that vehicle speeds could not be brought in line with the gearshift behaviour of the in-use data.

Figure 14: Definition of power to mass ratio classes for a simplified gearshift prescription

6 Driveability Tests

Right after the WMTC cycle and the corresponding gearshift procedure were developed measurements were carried out on roller benches in order to validate the driveability of the cycles and the functionality of the gearshift procedure.

In order to run these tests a test protocol was developed on the basis of the test protocol of the US certification procedure FTP. Some modifications were necessary due to the different design of the WMTC cycle (higher vehicle speeds, 3 parts) and the gearshift procedure. The

gearshift protocol represented EU/US gearshift behaviour because the Japanese gearshift behaviour database was not complete at that time.

In total the results (roller speed data) of 27 vehicles were delivered, 18 from Europe, 6 from Japan and 2 from the US.

The driveability problems that were reported can be focussed on tyre slip, wheel lock and traceability problems due to poor power in case of low power vehicles. In addition some malfunctions of the gearshift calculation sheet were detected.

The problem with tyre slip and traceability was biggest for part 1 and smallest for part 3. It is obviously related to the individual roller-tyre combination. An additional questionnaire was sent out to all participants in order to get further information about the roller benches as well as about the tyres used for the measurements. The results of the questionnaire show big variations in technical specifications (diameter, max. power, max. speed) of the roller benches. The tyre slip problem could neither be related to tyre type or size nor to vehicle specifications. It is tyre related rather than roller bench related but the available tyre information is not suitable to show a clear picture about the influencing parameters. No tyre slip problems were reported for roller benches with “textured” surfaces. The results of the questionnaire do not suggest further reductions of the cycle dynamics during acceleration phases. The risk of tyre slip can be reduced by textured roller surfaces.

The wheel lock problem is partly caused by the fact that only the rear wheel break can be used during deceleration on a roller test bench and partly related to the tyre characteristics like the tyre slip problem. As there is no significant influence of the deceleration on the emissions the wheel lock problem can be reduced by a reduction of the deceleration values.

The poor power problem can only be avoided when the cycle dynamics are adjusted to the vehicles at the lower end of the power to mass ratio scale. But this solution would not be in line with practical use. Nevertheless countermeasures to the poor power problem should be further investigated.

7 Vehicle Classification

The vehicle classification is one of the important issues of the WMTC development process. For practical reasons the following first provisional classification of vehicles was made by TNO within the frame of the cycle development work:

- C-class I: vehicles with an engine capacity of $< 150 \text{ cm}^3$
- C-class II: vehicles with an engine capacity of $150 \text{ cc} - 450 \text{ cm}^3$
- C-class III: vehicles with an engine capacity of $> 450 \text{ cm}^3$

During the analysis of the driveability validation test results some conflicts with practical use and technical possibilities revealed for this classification. On one hand there is a series of vehicles on the European market that would be classified as C-class I or C-class II although their max. speed exceeds the max. speed of the corresponding cycle parts substantially (see Table 12). On the other hand there are also vehicles of C-class 2 and C-class 3 whose max. speed is below the max. speed of the corresponding cycle parts.

max. vehicle speed	engine capacity		
	<= 150 cm ³	> 150 cm ³ <= 450 cm ³	> 450 cm ³
<= 95 km/h	48.3%	6.7%	0.2%
> 95 km/h <= 125 km/h	50.3%	70.0%	1.1%
> 125 km/h	1.4%	23.3%	98.7%
sum	100.0%	100.0%	100.0%

Table 12: Vehicle type distribution for engine capacity and max. vehicle speed classes (data source: KBA statistics of type approval values)

For that reason some alternatives based on power to mass ratio and max. vehicle speed as substitute or additional criteria were discussed but the FE-group could not find a compromise. It was decided to postpone a final decision till the analysis of the emissions validation test results will have been finished.

For the emissions validation tests the following provisional classification was used in order to get as much information as possible about the “border” areas:

- Pclass I: vehicles with a max. speed of less than 80 km/h,
- Pclass II: vehicles with a max. speed of 80 km/h or higher but less than 120 km/h,
- Pclass III: vehicles with a max. speed of 120 km/h or higher

Max. speed is the maximum vehicle speed as declared by the manufacturer.

Since the existing classifications for motorcycle type approval in all three regions use engine capacity classes, the FE group reached an agreement that the classification system should be based on engine capacity and maximum vehicle speed.

It was also agreed that the lower limit for class I is formed by engine capacity of more than 50 cm³ and max. speed of more than 50 km/h, that special class I is defined by engine capacity of up to 50 cm³ and max. speed of more than 50 km/h but not more than 60 km/h and that vehicles with an engine capacity below 150 cm³ should belong either to class I or class II but not to class III.

The proposals for a max. speed border between class I and class II on one hand and class II and class III on the other hand that are currently under discussion are justified by two contrasting philosophies about the driveability capabilities. Some members of the group argue that the classification must be defined in a way that the traceability is guaranteed for any cycle part, while some others would accept deviations from the cycle trace resulting in full throttle operation for about 10% of the total cycle time in order to reproduce the practical use and in order to cover a wider area of the engine map. These contrary philosophies result in different proposals for max. speed borders between class I and II (80 km/h versus 120 km/h) and class II and class III (120 km/h versus 140 km/h).

8 Weighting Factors for an Overall WMTC Emissions Result

Another open question besides the vehicle classification is the calculation of an overall emissions result for class 2 and class 3 vehicles. As already mentioned in chapter 4.4 it is necessary to apply weightings to the emissions results of the different cycle parts in order to calculate an overall result that reflects the statistics of vehicle use, because otherwise the equal time length of 600 s for each cycle part leads to a coincidental weighting of 14% for part 1, 31% for part 2 and 55% for part 3 that is not in line with practical use .

At the 8th WMTC FE meeting in Ann Arbor JARI presented a calculation method that is based on the following in-use parameters:

- annual mileage for different road category,
- average one trip (engine start to stop) distance,
- equivalent cold start ratio

The equivalent cold start ratio is estimated by the soak time distribution and cold start factors. The cold start factor is 100% for soak times > 6 hours and is 0% when the coolant temperature reaches the temperature at hot condition. The equivalent cold start ratio is calculated by summarising the soak time frequency (derived from traffic surveys) multiplied with the cold start factor.

The weightings for the different cycle parts are derived from the annual mileage for different road categories. The weighting for part 1 is then splitted into a weighting for part 1, cold and part 1, hot. The weighting for part 1, cold is derived from the average one trip distance, the distance driven in part 1 and the equivalent cold start ratio. The weighting for part 1, hot is the difference between the total weighting for part 1 (derived from the annual mileage for urban use) and the weighting for part 1, cold.

The FE group agreed on the use of the Japanese approach for the weighting calculation. The Japanese delegates made also a proposal for a simplification in order to skip the measurement of part 1, hot for class II and class III vehicles, which was accepted by the majority of the FE group. But, since equivalent reliable statistical data about cold start ratios, average trip length and annual mileage distribution for different road categories are missing for the two other regions (Europe and US) and since the calculation method reacts very sensitive on variations of these values, a common proposal for the weightings is still an unresolved issue.

9 Emissions Validation Tests

9.1 General Information

One important step for the whole project was the emissions validation programme.

The following decisions/recommendations were made with respect to the emissions validation programme by the WMTC group:

1. Cycle version 7 (the latest version at that time) should be used for the bench tests, part 1 should be measured with cold start first and then repeated at the end in warm condition.

3. In case of poor power the cycle trace should be followed as good as possible.
4. The following provisional vehicle classification (indicated in tables and figures as "Pclass") should be used for the emissions validation programme:
 - Cycle part 1 is mandatory for all vehicles,
 - Part 2 should be driven if $v_{max} \geq 80$ km/h,
 - Part 3 should be driven if $v_{max} \geq 120$ km/h.

v_{max} is the maximum vehicle speed as declared by the manufacturer.
5. The gearshift procedure as described in chapter 5 should be applied. The use of higher engine speeds were allowed for driveability or practicability reasons.

To be able to start this programme in September 2000 updates of the test protocol, the gear-shift procedure and the results delivery format were carried out and distributed amongst the participants of this programme. 21 scooters and 38 motorcycles were announced to be measured within this programme.

The following cycles were mandatory:

- Draft WMTC cycle for emissions validation programme, latest version,
- Appropriate regional certification cycle according to the corresponding measurement procedure

For Europe the test cycle as described in COM 2000 314 final Commission proposal for amendment of 97/24, sec. 5.3.1, Appendix 1 should be used. Additional cycles like the European passenger car test cycle (98/69/EC, NEDC) for Europe were recommended. It was also recommended to measure additional conditions that can be used for off cycle emissions provisions.

The following guidelines were given for the road load settings:

It was recommended to perform coast down measurements on the road and use the results for the specification of load settings. If coast down measurements were not possible the settings of the US-FTP specifications should be used. If the max. speed of a vehicle as declared by the manufacturer was below 130 km/h and this speed could not be reached on the roller bench with the US-FTP test bench settings, they had to be adjusted until the max. speed was reached.

The following results should be delivered:

- Technical data of the vehicle including max. speed,
- Bag results of the emissions for each part of the WMTC and other test cycles,
- Roller speed with 1 Hz resolution, drive wheel speed if possible
- Engine speed for vehicles with automatic gearbox (1 Hz resolution),
- Emissions with 1 Hz resolution,
- Temperatures at exhaust tailpipe and CVS metering device (1 Hz resolution),
- Temperature, barometric pressure and humidity of test cell,
- Humidity of dilution air.

The results of 54 vehicles were delivered.

- ❑ only bag results: 3 vehicles,
- ❑ bag results and roller speed (second by second): 19 vehicles,
- ❑ bag results, roller speed and engine speed (second by second): 8 vehicles,
- ❑ bag results, roller speed and emissions (second by second): 11 vehicles,
- ❑ bag results, roller speed, engine speed and emissions (second by second): 9 vehicles,
- ❑ bag results, roller speed, drive wheel speed and emissions (second by second): 2 vehicles,
- ❑ bag results, roller speed, drive wheel speed, engine speed and emissions (second by second): 2 vehicles

The following problems occurred in some cases:

- ❑ Some participants were not able to measure emissions with 1 Hz resolution,
- ❑ The road load setting requirements were not fulfilled,
- ❑ The provisional vehicle classification was not met,
- ❑ The speed tolerances were not met,
- ❑ Only bag results were delivered,
- ❑ The wrong cycle version was used. (This vehicle was excluded from the analysis).

But 90% of the results could be used for further analysis. Table 13 shows an overview of the vehicle sample distribution for different regions and provisional vehicle classes. 83% of the vehicles were measured in Europe.

region	number	Pclass 1	Pclass 2	Pclass 3
EUR	45	10	16	19
JAPAN	6	2	2	2
USA	2			2
Sum	53	12	18	23

Table 13: Vehicle sample for the emissions validation test programme

Table 14 gives an overview of the distribution of engine type and reduction system within the vehicle sample, Table 15 shows the participating institutes/organisations and Table 16 contains the technical data of the vehicles.

It has to be pointed out that road load settings based on coast down measurements on road were recommended. If such coast down results were not available the settings of the US-FTP specifications should be used. But, these settings are no more up-to-date as the ISO/TC22/WG17 has shown on the basis of new measurements in Japan. In it's final report the ISO group presented a new list with updated settings. The differences between FTP and ISO/TC22/WG17 settings are depending on vehicle mass and speed. For 11 vehicles the road load settings of the US FTP were not appropriate, most of them are trial and enduro vehicles. It can be expected that for these vehicles the differences are significant.

engine type	reduction system	PClass 1	PClass 2	PClass 3
2-str	direct injection	1		
2-str	oxidation catalyst	4	1	
2-str	no	3	1	
4-str	3 way catalyst		2	9
4-str	3 way catalyst + Air injection			1
4-str	oxidation catalyst		1	4
4-str	oxidation catalyst + Air injection		1	1
4-str	air injection		4	3
4-str	no	4	8	5
	Sum	12	18	23

Table 14: Distribution of engine type and reduction system within the vehicle sample

region	institute	no of vehicles
Europe	ACEM	3
Europe	AECC	2
Europe	EMPA	2
Europe	HTA Biel	1
Europe	INTA	15
Europe	JRC	3
Europe	Ricardo	11
Europe	RWTÜV	8
Japan	JAMA	3
Japan	JARI	3
USA	Harley Davidson	2
	sum	53

Table 15: Institutes/organisations participating on the emissions validation test programme

region	no	engine type	reduction system	cap in cm ³	Pn in kW	v_max in km/h	max WMTC cycle part	max speed not reached
JAPAN	19	2-str	oxidation catalyst	49	4.8	60	1	x
EUR	15	2-str	oxidation catalyst	125	6.8	69	1	
EUR	42	2-str	oxidation catalyst	101	5.0	85	1	
EUR	43	4-str	no	96	5.6	82	1	
EUR	46	4-str	no	125	7.5	100	1	
EUR	48	2-str	no	250	6.8	75	1	
EUR	50	2-str	no	248	13.3	95	1	
EUR	71	2-str	no	125	8.2		1	
EUR	72	2-str	oxidation catalyst	84	6.3		1	
EUR	73	4-str	no	182	13.6		1	
EUR	79	2-str	Direct injection	49			1	
JAPAN	62	4-str	no	49	2.9	60	1	
EUR	16	2-str	no	272	14.0	82	2	x
EUR	17	4-str	no	649	8.8	98	2	x
EUR	41	4-str	Air injection	125	11.0	110	2	x
EUR	51	4-str	no	124	8.4	110	2	x
EUR	52	4-str	Air injection	125	11.0	103	2	x
JAPAN	63	4-str	Air injection	124	9.6	95	2	x
EUR	7	4-str	no	150	8.4	95	2	
EUR	31	4-str	3 way catalyst	125	11.0	100	2	
EUR	34	4-str	oxidation catalyst	124	8.0	90	2	
EUR	35	4-str	no	249	15.0	115	2	
EUR	47	4-str	no	249	14.7	115	2	
EUR	53	4-str	no	234	14.0	120	2	
EUR	54	4-str	no	239	14.3	125	2	
EUR	57	4-str	no	124	11.0	104	2	
EUR	67	4-str	3 way catalyst	125	11.0	103	2	
EUR	74	4-str	Air injection	150	8.8		2	
EUR	82	2-str	oxidation catalyst	50	6.7		2	
JAPAN	25	4-str	oxidation catalyst + Air injection	249	19.0	120	2	
EUR	36	4-str	oxidation catalyst	250	15.5	123	3	x
USA	28	4-str	oxidation catalyst	1449	25.0	130	3	x
EUR	13	4-str	oxidation catalyst	459	28.5	158	3	
EUR	32	4-str	3 way catalyst	1130	62.5	196	3	
EUR	38	4-str	3 way catalyst	1170	45.0	168	3	
EUR	39	4-str	3 way catalyst + Air injection	599	80.0	252	3	
EUR	40	4-str	3 way catalyst	1298	105.5	250	3	
EUR	60	4-str	oxidation catalyst	996	86.0	250	3	
EUR	65	4-str	no	748	54.4	185	3	
EUR	66	4-str	3 way catalyst	1171	72.0	200	3	
EUR	68	4-str	3 way catalyst	1064	67.0	220	3	
EUR	75	4-str	3 way catalyst	955	76.5		3	
EUR	76	4-str	oxidation catalyst + Air injection	790	44.5		3	
EUR	77	4-str	no	499	43.0		3	
EUR	78	4-str	Air injection	398	32.7		3	

Table 16: Technical data of the vehicles

9.2 Results of the Emissions Validation Programme

The results of the emissions validation tests are given in Table 17 to Table 20 in g/test and in Table 21 to Table 24 in g/km. Since the vehicle classification and the weightings are still under discussion the results for the WMTC are shown for each cycle part separately, no overall WMTC result was calculated and no comparison with the results of the regional cycles was carried out.

NEDC denominates the European passenger car test cycle (98/69/EC), TRIAS denominates the Japanese type approval test cycle that is a modified version of the ECE R 40.

A more detailed analysis of the validation test results can be summarised as follows:

The emissions variance is

- ❑ Dependent of individual engine control technique,
- ❑ Dependent of emission level,
- ❑ Independent of traceability,
- ❑ Not different from others if max. roller speed is below max set speed

High variances in emissions results within each vehicle group (engine type/reduction system) due to individual vehicle design, high overlap in range between different groups

The high variances of the emissions results indicate that there is a substantial optimisation potential in some cases. As a consequence substantially lower variances can be expected if the reduction systems are optimised in accordance to the WMTC.

Worldwide Harmonised Motorcycle Emissions Certification Procedure, Draft Technical Report

region	no	engine type	max WMTC cycle part	max speed not reached	NEDC	ECE R 40	WMTC, part 1, cold	WMTC, part 2	WMTC, part 3	WMTC, part 1, hot	US-FTP	TRIAS
JAPAN	19	2-str	1	x		8.403	16.240			9.510	25.964	8.403
EUR	15	2-str	1			31.140	41.597			22.070		
EUR	42	2-str	1			35.997	26.557			26.133		
EUR	43	4-str	1			3.310	3.553			3.170		
EUR	46	4-str	1			3.487	4.983			3.500		
EUR	48	2-str	1			114.817	54.190			57.227		
EUR	50	2-str	1			63.557	60.277			60.907		
EUR	71	2-str	1			66.367	50.347			56.533		
EUR	72	2-str	1			11.750	18.717			9.140		
EUR	73	4-str	1		8.440	2.880	2.825					
EUR	79	2-str	1		8.420	3.630	3.614					
JAPAN	62	4-str	1				3.598			3.042	7.659	2.787
EUR	16	2-str	2	x		58.083	40.680	65.910		37.750		
EUR	17	4-str	2	x		10.037	12.100	16.303		9.873		
EUR	41	4-str	2	x		7.573	10.090	18.390		8.477		
EUR	51	4-str	2	x		4.697	4.273	7.020		4.090		
EUR	52	4-str	2	x		5.957	7.973	12.207		5.867		
JAPAN	63	4-str	2	x			3.217	6.230		2.271	5.014	2.141
EUR	7	4-str	2			1.720	3.034	3.894		1.314		
EUR	31	4-str	2		5.627	1.342	3.139	3.041		0.817		
EUR	34	4-str	2		5.671	1.878	3.211	5.376		2.089		
EUR	35	4-str	2		9.123	5.050	4.043	6.900		4.340		
EUR	47	4-str	2			1.998	2.827	4.500		2.047		
EUR	53	4-str	2			8.190	11.693	15.350		7.283		
EUR	54	4-str	2			3.630	4.750	5.313		3.127		
EUR	57	4-str	2			5.782	7.149	8.103	5.566			
EUR	67	4-str	2		4.823	0.762	2.851	2.601		0.685		
EUR	74	4-str	2		15.080	12.540	11.569	13.830				
EUR	82	2-str	2		38.281	4.289	29.121	32.379				
JAPAN	25	4-str	2				2.880	4.603		2.454	5.619	0.987
EUR	36	4-str	3	x	5.728	2.345	2.890	4.722	7.298	1.867		
USA	28	4-str	3	x			11.704	5.404	6.278			
EUR	13	4-str	3			2.203	3.593	3.442	4.719	2.047		
EUR	32	4-str	3		5.811	0.515	6.280	1.584	1.616	1.893		
EUR	38	4-str	3		4.884	0.655	6.168	1.461	0.692	1.012		
EUR	39	4-str	3		5.067	1.434	4.052	3.757	10.856	5.423		
EUR	40	4-str	3		4.164	1.106	1.844	2.099	3.548	2.037		
EUR	60	4-str	3			4.941	9.492	8.151	11.582	6.398		
EUR	65	4-str	3			9.137	11.043	9.213	8.247	6.547		
EUR	66	4-str	3		4.922	0.662	5.328	1.871	2.732	1.026		
EUR	68	4-str	3		0.868	0.110	0.816	0.168	0.459	0.365		
EUR	75	4-str	3		7.890	3.230	4.428	6.046	11.342			
EUR	76	4-str	3		4.070	0.910	2.406	3.175	6.641			
EUR	77	4-str	3		10.660	6.120	5.812	9.459	10.183			
EUR	78	4-str	3		11.030	6.950	7.083	12.744	11.083			
EUR	80	4-str	3		4.753	1.241	0.403	3.423	5.627			
EUR	81	4-str	3		6.901	3.004	6.520	5.842	6.792			
EUR	83	4-str	3		8.872	2.446	4.307	6.692	7.831			
EUR	137	4-str	3		1.757	0.449	3.622	3.658	2.621	2.338		
EUR	160	4-str	3			5.476	5.945	8.809	7.101	4.756		
JAPAN	26	4-str	3		7.939		6.082	7.837	8.321	2.520	10.151	2.609
JAPAN	64	4-str	3		4.237		3.179	3.872	5.244	1.157	4.825	1.106
USA	27	4-str	3				18.027	8.202	6.855			

Table 17: Results of the emissions validation tests for HC in g/test

Worldwide Harmonised Motorcycle Emissions Certification Procedure, Draft Technical Report

region	no	engine type	max WMTC cycle part	max speed not reached	NEDC	ECE R 40	WMTC, part 1, cold	WMTC, part 2	WMTC, part 3	WMTC, part 1, hot	US-FTP	TRIAS
JAPAN	19	2-str	1	x		16.94	22.79			19.19	62.18	16.94
EUR	15	2-str	1			46.36	42.69			40.43		
EUR	42	2-str	1			71.39	61.92			60.20		
EUR	43	4-str	1			56.84	57.45			58.84		
EUR	46	4-str	1			53.00	51.99			56.13		
EUR	48	2-str	1			162.90	129.04			129.21		
EUR	50	2-str	1			132.93	124.56			121.31		
EUR	71	2-str	1			116.61	99.71			100.08		
EUR	72	2-str	1			47.52	38.64			49.26		
EUR	73	4-str	1		118.75	18.01	27.17					
EUR	79	2-str	1		6.68	1.91	2.88					
JAPAN	62	4-str	1				21.05			24.14	56.31	22.53
EUR	16	2-str	2	x		110.89	86.39	134.36		87.07		
EUR	17	4-str	2	x		170.94	165.64	288.43		176.25		
EUR	41	4-str	2	x		38.52	58.82	181.88		54.63		
EUR	51	4-str	2	x		62.91	56.96	204.97		69.65		
EUR	52	4-str	2	x		43.25	55.70	160.73		54.59		
JAPAN	63	4-str	2	x			41.46	125.23		47.33	110.08	39.77
EUR	7	4-str	2			13.10	15.00	63.27		15.14		
EUR	31	4-str	2		39.18	3.32	6.90	26.85		4.20		
EUR	34	4-str	2		117.15	12.50	21.49	101.61		22.08		
EUR	35	4-str	2		92.95	28.17	29.14	55.24		40.13		
EUR	47	4-str	2			38.20	31.57	91.34		36.76		
EUR	53	4-str	2			127.59	140.43	261.43		122.19		
EUR	54	4-str	2			61.80	65.73	110.01		69.45		
EUR	57	4-str	2			30.58	25.41	65.70	24.06			
EUR	67	4-str	2		50.95	3.26	7.96	30.39		4.70		
EUR	74	4-str	2		72.25	23.29	29.69	63.06				
EUR	82	2-str	2		41.20	2.51	29.80	116.75				
JAPAN	25	4-str	2				30.04	145.63		33.25	105.20	19.65
EUR	36	4-str	3	x	173.11	61.78	63.12	120.89	211.01	53.00		
USA	28	4-str	3	x			64.78	24.81	216.69			
EUR	13	4-str	3			17.26	24.26	36.33	86.20	19.22		
EUR	32	4-str	3		52.38	6.69	55.73	21.88	19.01	21.13		
EUR	38	4-str	3		83.95	15.11	81.87	24.33	31.03	21.12		
EUR	39	4-str	3		41.21	1.91	25.11	32.54	161.72	18.72		
EUR	40	4-str	3		14.57	4.56	10.45	7.74	8.75	4.83		
EUR	60	4-str	3			4.94	12.33	12.84	78.73	5.64		
EUR	65	4-str	3			29.03	33.76	37.68	50.21	29.65		
EUR	66	4-str	3		21.47	2.96	18.21	9.30	12.81	3.95		
EUR	68	4-str	3		4.17	0.66	3.36	0.71	3.06	1.39		
EUR	75	4-str	3		70.83	25.32	39.67	54.10	104.96			
EUR	76	4-str	3		114.60	20.06	51.54	70.92	262.01			
EUR	77	4-str	3		162.28	82.79	62.47	127.53	407.77			
EUR	78	4-str	3		75.49	21.15	26.92	57.41	250.05			
EUR	80	4-str	3		27.60	6.83	2.72	18.99	40.97			
EUR	81	4-str	3		139.73	34.40	45.42	125.15	478.89			
EUR	83	4-str	3		126.34	32.09	33.52	101.68	432.86			
EUR	137	4-str	3		25.88	7.16	86.37	73.70	37.88	77.99		
EUR	160	4-str	3			65.51	45.97	86.70	152.18	45.25		
JAPAN	26	4-str	3		155.63		38.48	130.64	502.61	43.45	114.40	26.34
JAPAN	64	4-str	3		20.43		13.12	8.24	14.30	2.20	18.36	2.07
USA	27	4-str	3				47.68	24.70	126.43			

Table 18: Results of the emissions validation tests for CO in g/test

Worldwide Harmonised Motorcycle Emissions Certification Procedure, Draft Technical Report

region	no	engine type	max WMTC cycle part	max speed not reached	NEDC	ECE R 40	WMTC, part 1, cold	WMTC, part 2	WMTC, part 3	WMTC, part 1, hot	US-FTP	TRIAS
JAPAN	19	2-str	1	x			0.142			0.149	0.251	0.039
EUR	15	2-str	1			0.039	0.080			0.077		
EUR	42	2-str	1			0.023	0.047			0.030		
EUR	43	4-str	1			0.427	0.573			0.497		
EUR	46	4-str	1			0.290	0.563			0.437		
EUR	48	2-str	1			0.010	0.020			0.017		
EUR	50	2-str	1			0.030	0.037			0.030		
EUR	71	2-str	1			0.047	0.097			0.110		
EUR	72	2-str	1			0.020	0.047			0.020		
EUR	73	4-str	1		2.810	0.550	0.692					
EUR	79	2-str	1		5.590	1.720	1.608					
JAPAN	62	4-str	1				0.936			0.801	3.087	0.834
EUR	16	2-str	2	x		0.037	0.047	0.700		0.043		
EUR	17	4-str	2	x		0.270	0.253	2.207		0.230		
EUR	41	4-str	2	x		0.730	0.783	2.100		0.553		
EUR	51	4-str	2	x		0.533	0.630	1.510		0.350		
EUR	52	4-str	2	x		0.430	0.640	2.037		0.383		
JAPAN	63	4-str	2	x			0.641	2.188		0.500	1.444	0.510
EUR	7	4-str	2			0.919	1.245	2.673		0.756		
EUR	31	4-str	2		4.365	0.826	1.620	3.625		0.807		
EUR	34	4-str	2		1.681	0.519	0.748	1.348		0.451		
EUR	35	4-str	2		3.999	0.577	0.890	4.364		0.512		
EUR	47	4-str	2			0.609	0.893	2.950		0.843		
EUR	53	4-str	2			0.140	0.157	0.567		0.133		
EUR	54	4-str	2			0.433	0.530	2.570		0.487		
EUR	57	4-str	2			0.825	1.148	3.778	1.054			
EUR	67	4-str	2		3.675	0.666	1.665	3.745		0.757		
EUR	74	4-str	2		4.750	0.860	0.882	5.317				
EUR	82	2-str	2		0.288	0.206	0.223	0.347				
JAPAN	25	4-str	2				0.539	1.454		0.419	2.015	0.376
EUR	36	4-str	3	x	2.281	0.314	0.605	1.858	10.414	0.532		
USA	28	4-str	3	x			1.459	7.682	16.779			
EUR	13	4-str	3			0.412	1.628	2.609	7.438	0.712		
EUR	32	4-str	3		1.045	0.123	0.247	0.479	3.729	0.263		
EUR	38	4-str	3		1.209	0.188	0.437	1.226	4.130	0.358		
EUR	39	4-str	3		0.901	0.179	0.169	0.482	2.729	0.325		
EUR	40	4-str	3		2.087	0.230	0.351	0.992	10.820	0.360		
EUR	60	4-str	3			0.691	0.959	4.833	10.557	1.092		
EUR	65	4-str	3			0.557	0.597	2.817	16.440	0.627		
EUR	66	4-str	3		6.356	0.761	1.152	4.176	20.862	0.765		
EUR	68	4-str	3		0.172	0.087	0.252	0.277	0.763	0.204		
EUR	75	4-str	3		2.990	0.270	0.473	1.832	14.886			
EUR	76	4-str	3		1.140	0.160	0.352	1.039	5.373			
EUR	77	4-str	3		2.150	0.370	0.639	1.992	5.435			
EUR	78	4-str	3		2.920	0.450	0.717	2.975	9.712			
EUR	80	4-str	3		2.456	0.116	0.202	0.739	4.918			
EUR	81	4-str	3		2.631	0.604	0.846	2.332	5.734			
EUR	83	4-str	3		3.783	0.727	1.178	3.435	7.733			
EUR	137	4-str	3		1.843	0.264	0.486	1.643	6.546	0.399		
EUR	160	4-str	3			0.542	0.726	2.426	10.332	0.639		
JAPAN	26	4-str	3		4.792		1.955	4.352	8.196	1.158	5.766	0.939
JAPAN	64	4-str	3		2.023		0.509	1.177	7.835	0.310	1.988	0.310
USA	27	4-str	3				0.974	6.457	26.977			

Table 19: Results of the emissions validation tests for NOx in g/test

Worldwide Harmonised Motorcycle Emissions Certification Procedure, Draft Technical Report

region	no	engine type	max WMTC cycle part	max speed not reached	NEDC	ECE R 40	WMTC, part 1, cold	WMTC, part 2	WMTC, part 3	WMTC, part 1, hot	US-FTP	TRIAS
JAPAN	19	2-str	1	x			176.6			184.9	477.9	180.3
EUR	15	2-str	1			179.6	169.3			171.9		
EUR	42	2-str	1			221.5	186.8			198.6		
EUR	43	4-str	1			176.8	182.6			169.0		
EUR	46	4-str	1			156.9	181.9			156.2		
EUR	48	2-str	1			139.8	145.9			131.9		
EUR	50	2-str	1			189.3	169.0			157.4		
EUR	71	2-str	1			139.3	133.9			128.1		
EUR	72	2-str	1			273.2	239.1			240.8		
EUR	73	4-str	1		699.0	293.6	289.1					
EUR	79	2-str	1		407.5	142.1	159.6					
JAPAN	62	4-str	1				90.4			85.8	259.8	91.7
EUR	16	2-str	2	x		192.9	176.2	483.8		155.0		
EUR	17	4-str	2	x		317.3	293.6	539.5		258.9		
EUR	41	4-str	2	x		221.7	203.4	439.5		184.4		
EUR	51	4-str	2	x		201.5	224.3	401.9		178.2		
EUR	52	4-str	2	x		193.8	204.2	414.1		188.6		
JAPAN	63	4-str	2	x			186.2	358.2		162.8	411.7	193.0
EUR	7	4-str	2			307.1	316.2	610.2		293.9		
EUR	31	4-str	2		797.0	313.8	303.4	602.4		276.9		
EUR	34	4-str	2		477.6	202.2	192.7	343.5		170.9		
EUR	35	4-str	2		654.5	262.0	245.5	470.8		183.8		
EUR	47	4-str	2			255.5	253.8	407.6		205.2		
EUR	53	4-str	2			178.9	180.4	369.0		157.0		
EUR	54	4-str	2			215.9	237.3	499.7		194.8		
EUR	57	4-str	2			291.7	305.0	501.8	271.4			
EUR	67	4-str	2		744.6	293.2	284.2	577.6		270.5		
EUR	74	4-str	2		644.7	235.2	178.0	443.6				
EUR	82	2-str	2		412.1	214.1	107.6	366.2				
JAPAN	25	4-str	2				285.1	443.1		246.2	696.2	315.9
EUR	36	4-str	3	x	604.1	268.0	254.2	391.5	945.3	220.7		
USA	28	4-str	3	x			670.3	1086.9	1913.6			
EUR	13	4-str	3			468.5	501.1	710.0	1374.4	398.7		
EUR	32	4-str	3		1644.5	790.9	690.6	1111.4	2062.9	670.2		
EUR	38	4-str	3		1295.0	672.0	574.6	864.1	1554.3	573.0		
EUR	39	4-str	3		1418.6	644.7	635.0	924.1	1629.1	523.2		
EUR	40	4-str	3		1533.7	783.4	733.1	998.2	1789.3	649.1		
EUR	60	4-str	3			637.2	579.0	888.4	1537.3	570.0		
EUR	65	4-str	3			692.5	596.4	933.7	1883.3	524.9		
EUR	66	4-str	3		1476.5	691.5	665.2	1053.2	2075.5	599.8		
EUR	68	4-str	3		1542.8	817.7	764.1	1003.5	1733.1	660.1		
EUR	75	4-str	3		1327.9	657.1	596.2	884.7	1600.3			
EUR	76	4-str	3		1183.4	556.6	596.7	857.3	1571.5			
EUR	77	4-str	3		830.4	336.4	353.1	577.8	1283.8			
EUR	78	4-str	3		719.1	320.4	259.1	490.1	1185.4			
EUR	80	4-str	3		1488.2	755.5	125.9	1034.3	1889.0			
EUR	81	4-str	3		590.3	235.6	224.7	404.2	890.8			
EUR	83	4-str	3		1055.5	493.0	476.2	684.3	1398.6			
EUR	137	4-str	3		929.7	464.4	355.9	539.3	1164.9	313.1		
EUR	160	4-str	3			566.3	441.2	690.3	1244.3	459.2		
JAPAN	26	4-str	3		953.2		418.2	632.2	1332.1	348.9	963.7	414.4
JAPAN	64	4-str	3		1425.7		699.4	1010.2	1857.9	626.6	1568.6	683.5
USA	27	4-str	3				463.9	789.4	1607.0			

Table 20: Results of the emissions validation tests for CO2 in g/test

region	no	engine type	max WMTC cycle part	max speed not reached	NEDC	ECE R 40	WMTC, part 1, cold	WMTC, part 2	WMTC, part 3	WMTC, part 1, hot	US-FTP	TRIAS
JAPAN	19	2-str	1	x			4.006			2.347	2.387	2.105
EUR	15	2-str	1			7.787	10.158			5.413		
EUR	42	2-str	1			9.038	6.483			6.398		
EUR	43	4-str	1			0.828	0.880			0.781		
EUR	46	4-str	1			0.874	1.225			0.865		
EUR	48	2-str	1			28.709	13.441			14.118		
EUR	50	2-str	1			15.984	14.759			14.986		
EUR	71	2-str	1			16.647	12.444			13.960		
EUR	72	2-str	1			2.953	4.632			2.267		
EUR	73	4-str	1		0.781	0.727	0.691					
EUR	79	2-str	1		0.841	0.915	0.886					
JAPAN	62	4-str	1				0.902			0.760	0.708	0.698
EUR	16	2-str	2	x		14.533	10.054	7.489		9.234		
EUR	17	4-str	2	x		2.502	2.973	1.825		2.412		
EUR	41	4-str	2	x		1.897	2.490	2.064		2.131		
EUR	51	4-str	2	x		1.178	1.045	0.783		1.006		
EUR	52	4-str	2	x		1.491	1.962	1.371		1.435		
JAPAN	63	4-str	2	x			0.793	0.692		0.559	0.463	0.536
EUR	7	4-str	2			0.430	0.759	0.430		0.324		
EUR	31	4-str	2		0.536	0.339	0.770	0.333		0.200		
EUR	34	4-str	2		0.536	0.477	0.795	0.594		0.514		
EUR	35	4-str	2		0.873	1.281	1.004	0.763		1.069		
EUR	47	4-str	2			0.500	0.694	0.495		0.504		
EUR	53	4-str	2			2.050	2.881	1.693		1.795		
EUR	54	4-str	2			0.909	1.170	0.584		0.768		
EUR	57	4-str	2			1.419	1.831	0.888	1.364			
EUR	67	4-str	2		0.454	0.191	0.699	0.286		0.168		
EUR	74	4-str	2		1.429	3.178	2.864	1.523				
EUR	82	2-str	2		3.757	1.077	7.233	3.789				
JAPAN	25	4-str	2				0.711	0.504		0.604	0.469	0.247
EUR	36	4-str	3	x	0.534	0.593	0.715	0.520	0.466	0.461		
USA	28	4-str	3	x			2.875	0.594	0.400			
EUR	13	4-str	3			0.552	0.881	0.378	0.301	0.498		
EUR	32	4-str	3		0.543	0.131	1.553	0.174	0.103	0.465		
EUR	38	4-str	3		0.454	0.170	1.533	0.160	0.044	0.250		
EUR	39	4-str	3		0.471	0.367	1.003	0.413	0.689	1.350		
EUR	40	4-str	3		0.388	0.282	0.456	0.232	0.226	0.501		
EUR	60	4-str	3			1.217	2.328	0.891	0.734	1.566		
EUR	65	4-str	3			2.244	2.657	1.003	0.523	1.563		
EUR	66	4-str	3		0.447	0.168	1.313	0.206	0.174	0.251		
EUR	68	4-str	3		0.081	0.029	0.204	0.018	0.029	0.090		
EUR	75	4-str	3		0.734	0.819	1.091	0.663	0.720			
EUR	76	4-str	3		0.378	0.232	0.593	0.347	0.422			
EUR	77	4-str	3		0.994	1.557	1.432	1.041	0.649			
EUR	78	4-str	3		1.029	1.790	1.730	1.398	0.705			
EUR	80	4-str	3		0.439	0.313	0.100	0.376	0.358			
EUR	81	4-str	3		0.638	0.757	1.606	0.642	0.438			
EUR	83	4-str	3		0.821	0.617	1.065	0.734	0.497			
EUR	137	4-str	3		0.163	0.115	0.900	0.403	0.167	0.581		
EUR	160	4-str	3			1.345	1.453	0.963	0.452	1.159		
JAPAN	26	4-str	3		0.721		1.498	0.860	0.529	0.621	0.846	0.653
JAPAN	64	4-str	3		0.384		0.782	0.424	0.333	0.284	0.402	0.277
USA	27	4-str	3				4.434	0.899	0.438			

Table 21: Results of the emissions validation tests for HC in g/km

Worldwide Harmonised Motorcycle Emissions Certification Procedure, Draft Technical Report

region	no	engine type	max WMTC cycle part	max speed not reached	NEDC	ECE R 40	WMTC, part 1, cold	WMTC, part 2	WMTC, part 3	WMTC, part 1, hot	US-FTP	TRIAS
JAPAN	19	2-str	1	x			5.62			4.74	5.72	4.24
EUR	15	2-str	1			11.59	10.42			9.92		
EUR	42	2-str	1			17.92	15.12			14.74		
EUR	43	4-str	1			14.22	14.22			14.50		
EUR	46	4-str	1			13.28	12.77			13.87		
EUR	48	2-str	1			40.73	32.01			31.88		
EUR	50	2-str	1			33.43	30.50			29.85		
EUR	71	2-str	1			29.25	24.64			24.71		
EUR	72	2-str	1			11.95	9.56			12.22		
EUR	73	4-str	1		10.99	4.55	6.65					
EUR	79	2-str	1		0.67	0.48	0.71					
JAPAN	62	4-str	1				5.28			6.03	5.21	5.64
EUR	16	2-str	2	x		27.75	21.35	15.26		21.30		
EUR	17	4-str	2	x		42.63	40.71	32.28		43.06		
EUR	41	4-str	2	x		9.65	14.52	20.41		13.72		
EUR	51	4-str	2	x		15.78	13.94	22.85		17.12		
EUR	52	4-str	2	x		10.82	13.70	18.05		13.35		
JAPAN	63	4-str	2	x			10.22	13.91		11.66	10.17	9.95
EUR	7	4-str	2			3.28	3.75	6.99		3.73		
EUR	31	4-str	2		3.73	0.84	1.69	2.94		1.03		
EUR	34	4-str	2		11.08	3.17	5.32	11.22		5.43		
EUR	35	4-str	2		8.89	7.15	7.24	6.11		9.88		
EUR	47	4-str	2			9.55	7.75	10.06		9.05		
EUR	53	4-str	2			31.93	34.59	28.83		30.11		
EUR	54	4-str	2			15.48	16.19	12.09		17.05		
EUR	57	4-str	2			7.50	6.49	7.20	5.90			
EUR	67	4-str	2		4.79	0.82	1.95	3.34		1.15		
EUR	74	4-str	2		6.85	5.90	7.35	6.94				
EUR	82	2-str	2		4.04	0.63	7.40	13.66				
JAPAN	25	4-str	2				7.41	15.96		8.19	8.77	4.91
EUR	36	4-str	3	x	16.14	15.63	15.62	13.32	13.47	13.08		
USA	28	4-str	3	x			15.91	2.73	13.81			
EUR	13	4-str	3			4.32	5.95	3.99	5.50	4.68		
EUR	32	4-str	3		4.90	1.71	13.78	2.41	1.21	5.20		
EUR	38	4-str	3		7.80	3.91	20.34	2.67	1.97	5.21		
EUR	39	4-str	3		3.83	0.49	6.21	3.58	10.27	4.66		
EUR	40	4-str	3		1.36	1.16	2.58	0.86	0.56	1.19		
EUR	60	4-str	3			1.22	3.02	1.40	4.99	1.38		
EUR	65	4-str	3			7.13	8.12	4.10	3.19	7.08		
EUR	66	4-str	3		1.95	0.75	4.49	1.02	0.81	0.97		
EUR	68	4-str	3		0.39	0.17	0.84	0.08	0.19	0.34		
EUR	75	4-str	3		6.59	6.42	9.77	5.93	6.66			
EUR	76	4-str	3		10.64	5.12	12.71	7.76	16.63			
EUR	77	4-str	3		15.13	21.07	15.40	14.03	25.97			
EUR	78	4-str	3		7.04	5.45	6.58	6.30	15.91			
EUR	80	4-str	3		2.55	1.72	0.67	2.09	2.61			
EUR	81	4-str	3		12.92	8.67	11.19	13.76	30.85			
EUR	83	4-str	3		11.69	8.10	8.29	11.15	27.45			
EUR	137	4-str	3		2.40	1.83	21.45	8.11	2.41	19.38		
EUR	160	4-str	3			16.09	11.24	9.47	9.69	11.02		
JAPAN	26	4-str	3		14.13		9.47	14.34	31.95	10.70	9.53	6.60
JAPAN	64	4-str	3		1.85		3.23	0.90	0.91	0.54	1.53	0.52
USA	27	4-str	3				11.73	2.71	8.08			

Table 22: Results of the emissions validation tests for CO in g/km

Worldwide Harmonised Motorcycle Emissions Certification Procedure, Draft Technical Report

region	no	engine type	max WMTC cycle part	max speed not reached	NEDC	ECE R 40	WMTC, part 1, cold	WMTC, part 2	WMTC, part 3	WMTC, part 1, hot	US-FTP	TRIAS
JAPAN	19	2-str	1	x			0.035			0.037	0.023	0.010
EUR	15	2-str	1			0.010	0.020			0.019		
EUR	42	2-str	1			0.006	0.011			0.007		
EUR	43	4-str	1			0.107	0.142			0.122		
EUR	46	4-str	1			0.073	0.138			0.108		
EUR	48	2-str	1			0.003	0.005			0.004		
EUR	50	2-str	1			0.008	0.009			0.007		
EUR	71	2-str	1			0.012	0.024			0.027		
EUR	72	2-str	1			0.005	0.012			0.005		
EUR	73	4-str	1		0.260	0.139	0.169					
EUR	79	2-str	1		0.558	0.433	0.394					
JAPAN	62	4-str	1				0.234			0.200	0.285	0.209
EUR	16	2-str	2	x		0.009	0.012	0.080		0.011		
EUR	17	4-str	2	x		0.067	0.062	0.247		0.056		
EUR	41	4-str	2	x		0.183	0.193	0.236		0.139		
EUR	51	4-str	2	x		0.134	0.154	0.168		0.086		
EUR	52	4-str	2	x		0.108	0.158	0.229		0.094		
JAPAN	63	4-str	2	x			0.158	0.243		0.123	0.133	0.128
EUR	7	4-str	2			0.230	0.311	0.295		0.186		
EUR	31	4-str	2		0.416	0.209	0.397	0.397		0.198		
EUR	34	4-str	2		0.159	0.132	0.185	0.149		0.111		
EUR	35	4-str	2		0.382	0.146	0.221	0.483		0.126		
EUR	47	4-str	2			0.152	0.219	0.325		0.208		
EUR	53	4-str	2			0.035	0.039	0.062		0.033		
EUR	54	4-str	2			0.109	0.131	0.283		0.120		
EUR	57	4-str	2			0.203	0.293	0.414	0.258			
EUR	67	4-str	2		0.346	0.167	0.408	0.412		0.186		
EUR	74	4-str	2		0.450	0.218	0.218	0.585				
EUR	82	2-str	2		0.028	0.052	0.055	0.041				
JAPAN	25	4-str	2				0.133	0.159		0.103	0.168	0.094
EUR	36	4-str	3	x	0.213	0.080	0.150	0.205	0.665	0.131		
USA	28	4-str	3	x			0.359	0.844	1.071			
EUR	13	4-str	3			0.103	0.400	0.286	0.475	0.173		
EUR	32	4-str	3		0.098	0.031	0.061	0.053	0.237	0.065		
EUR	38	4-str	3		0.112	0.049	0.108	0.135	0.263	0.088		
EUR	39	4-str	3		0.084	0.046	0.042	0.053	0.173	0.081		
EUR	40	4-str	3		0.194	0.059	0.087	0.110	0.688	0.089		
EUR	60	4-str	3			0.170	0.235	0.528	0.669	0.267		
EUR	65	4-str	3			0.137	0.144	0.307	1.043	0.150		
EUR	66	4-str	3		0.578	0.193	0.284	0.459	1.326	0.187		
EUR	68	4-str	3		0.016	0.022	0.063	0.031	0.049	0.050		
EUR	75	4-str	3		0.278	0.068	0.116	0.201	0.945			
EUR	76	4-str	3		0.106	0.041	0.087	0.114	0.341			
EUR	77	4-str	3		0.200	0.094	0.157	0.219	0.346			
EUR	78	4-str	3		0.272	0.116	0.175	0.326	0.618			
EUR	80	4-str	3		0.227	0.029	0.050	0.081	0.313			
EUR	81	4-str	3		0.243	0.152	0.208	0.256	0.369			
EUR	83	4-str	3		0.350	0.183	0.291	0.377	0.490			
EUR	137	4-str	3		0.171	0.067	0.121	0.181	0.416	0.099		
EUR	160	4-str	3			0.133	0.177	0.265	0.658	0.156		
JAPAN	26	4-str	3		0.435		0.482	0.478	0.521	0.285	0.480	0.235
JAPAN	64	4-str	3		0.184		0.125	0.129	0.497	0.076	0.166	0.078
USA	27	4-str	3				0.239	0.708	1.724			

Table 23: Results of the emissions validation tests for NOx in g/km

Worldwide Harmonised Motorcycle Emissions Certification Procedure, Draft Technical Report

region	no	engine type	max WMTC cycle part	max speed not reached	NEDC	ECE R 40	WMTC, part 1, cold	WMTC, part 2	WMTC, part 3	WMTC, part 1, hot	US-FTP	TRIAS
JAPAN	19	2-str	1	x			43.6			45.6	43.9	45.2
EUR	15	2-str	1			44.9	41.3			42.2		
EUR	42	2-str	1			55.6	45.6			48.6		
EUR	43	4-str	1			44.2	45.2			41.6		
EUR	46	4-str	1			39.3	44.7			38.6		
EUR	48	2-str	1			35.0	36.2			32.5		
EUR	50	2-str	1			47.6	41.4			38.7		
EUR	71	2-str	1			34.9	33.1			31.6		
EUR	72	2-str	1			68.7	59.2			59.7		
EUR	73	4-str	1		64.7	74.1	70.7					
EUR	79	2-str	1		40.7	35.8	39.1					
JAPAN	62	4-str	1				22.7			21.4	24.0	23.0
EUR	16	2-str	2	x		48.3	43.5	55.0		37.9		
EUR	17	4-str	2	x		79.1	72.2	60.4		63.3		
EUR	41	4-str	2	x		55.5	50.2	49.3		46.3		
EUR	51	4-str	2	x		50.5	54.9	44.8		43.8		
EUR	52	4-str	2	x		48.5	50.3	46.5		46.1		
JAPAN	63	4-str	2	x			45.9	39.8		40.1	38.0	48.3
EUR	7	4-str	2			76.9	79.1	67.4		72.5		
EUR	31	4-str	2		76.0	79.2	74.4	66.0		67.8		
EUR	34	4-str	2		45.2	51.3	47.7	37.9		42.1		
EUR	35	4-str	2		62.5	66.5	61.0	52.1		45.3		
EUR	47	4-str	2			63.9	62.3	44.8		50.5		
EUR	53	4-str	2			44.8	44.4	40.7		38.7		
EUR	54	4-str	2			54.1	58.4	54.9		47.8		
EUR	57	4-str	2			71.6	77.9	55.0	66.5			
EUR	67	4-str	2		70.1	73.4	69.7	63.5		66.4		
EUR	74	4-str	2		61.1	59.6	44.1	48.8				
EUR	82	2-str	2		40.4	53.8	26.7	42.9				
JAPAN	25	4-str	2			79.0	70.4	48.6		60.6	58.1	79.0
EUR	36	4-str	3	x	56.3	67.8	62.9	43.1	60.3	54.5		
USA	28	4-str	3	x			164.7	119.4	122.1			
EUR	13	4-str	3			117.4	123.0	77.9	87.7	97.0		
EUR	32	4-str	3		153.8	201.8	170.8	122.3	131.1	164.7		
EUR	38	4-str	3		120.3	173.8	142.8	94.9	98.8	141.3		
EUR	39	4-str	3		131.8	164.8	157.2	101.6	103.5	130.2		
EUR	40	4-str	3		142.8	200.1	181.3	110.5	113.8	159.8		
EUR	60	4-str	3			156.9	142.0	97.1	97.5	139.5		
EUR	65	4-str	3			170.1	143.5	101.7	119.5	125.3		
EUR	66	4-str	3		134.2	175.9	163.9	115.7	131.9	146.8		
EUR	68	4-str	3		143.3	210.9	190.5	110.6	110.3	162.5		
EUR	75	4-str	3		123.5	166.7	146.8	97.0	101.6			
EUR	76	4-str	3		109.9	142.0	147.1	93.8	99.8			
EUR	77	4-str	3		77.4	85.6	87.0	63.6	81.8			
EUR	78	4-str	3		67.1	82.5	63.3	53.8	75.4			
EUR	80	4-str	3		137.4	190.8	31.1	113.8	120.2			
EUR	81	4-str	3		54.6	59.4	55.4	44.4	57.4			
EUR	83	4-str	3		97.7	124.4	117.8	75.1	88.7			
EUR	137	4-str	3		86.1	118.6	88.4	59.4	74.0	77.8		
EUR	160	4-str	3			139.0	107.8	75.4	79.2	111.9		
JAPAN	26	4-str	3		86.5		103.0	69.4	84.7	85.9	80.3	103.8
JAPAN	64	4-str	3		129.4		172.0	110.7	117.9	154.1	130.8	171.2
USA	27	4-str	3				114.1	86.5	102.7			

Table 24: Results of the emissions validation tests for CO2 in g/km

10 Test Protocol

An update of the test protocol was worked out on the basis of the state of the discussion in the WMTC group so far and on the basis of the ISO work on updating ISO 11486 (Motorcycles - Chassis dynamometer setting method) and ISO 6460 (concerning the gas sampling and cooling aspects). This protocol is intended to build the basis for the preparation of the round robin test and is added as Annex C.

11 Round Robin Test

It is planned to start the round robin test in April 2003. A draft outline of the test foresees to test three vehicles (one per class) in different laboratories in all three regions. The aim is to get experience about the interpretation/application of the WMTC test procedure in different laboratories and to get reliable data for the calculation of the reproducibility of the WMTC test procedure. Results can be expected in the second half of 2003.

12 Off Cycle Emissions

The discussion has already been started, but this issue is subject of future work. It was recommended by JAMA to intensify the discussion in order to increase the margin for a vehicle classification compromise. Generic aspects and definitions that are worked out in the parallel working HDV- off cycle emission group (GRPE informal group) will be considered for the discussions in the WMTC group.

13 Summary and Conclusions

The developed test cycle and the accompanying gearshift procedure were tested in several laboratories in all three regions with respect to driveability. They form a good balance between representativity of in-use driving and bench test requirements like reproducibility. The dynamics of the WMTC cycle reflect the average driving behaviour for motorcycles in real live operation.

The final result that will be used for the round robin test starting in Spring 2003 is cycle version 8 with an added special part 1 for 50 cc vehicles.

The road load settings and other test conditions like cooling fan specifications were updated according to the outcome of the ISO work (see updated test protocol).

Although the requirements of the emissions validation programme were not fully met, there are enough valid results left for future analysis. All current reduction systems are represented in the vehicle sample; reduction systems were a bit underrepresented in provisional class 2, whereas the major part of the provisional class 3 vehicles was equipped with reductions systems.

Vehicle classification and weighting of the results are still open issues. The state of the current discussion is shown in this report.

With the developed test cycle, gearshift prescriptions and test protocol a world wide harmonised emissions test procedure for motorcycles can be established. The preparatory work for the start of the round robin test is finished. The major part of the emissions validation test results can be used for a comparison with regional emissions test procedures. With respect to the development of a GTR the open questions of vehicle classification and weighting of results need to be solved and off cycle emission provisions need to be discussed.

14 Literature

[1] R R.C. Rijkeboer,

WMTC – Final report, TNO Report 01.OR.VM.034.1/RR, by order of the Netherlands Ministry of the Environment (VROM), May 2001

[2] F. Schröder:

“Betriebsweise, Emissionen und Kraftstoffverbrauch von Motorrädern”. Thesis of the Technical University Darmstadt. Published as part of the series Fortschritt-Berichte VDI, Reihe 12, Nr. 435, May 2000

Annex A - Description of the Modification Work on the WMTC Cycle

The following modifications were carried out based on technical discussions in the WMTC group and preliminary tests by the industry.

TNO Automotive did first modifications on the WMTC cycle that are mainly related to the improvement of the driveability. These modifications concern cycle parts below 20 km/h, the smoothing of ripples for the cruising parts caused by vehicle speed measurement uncertainties and the max. speed of part 3 of the cycle. A detailed description of these modifications is given in [1].

The resulting cycle was named “version 3” and is shown in Figure 15 to Figure 17.

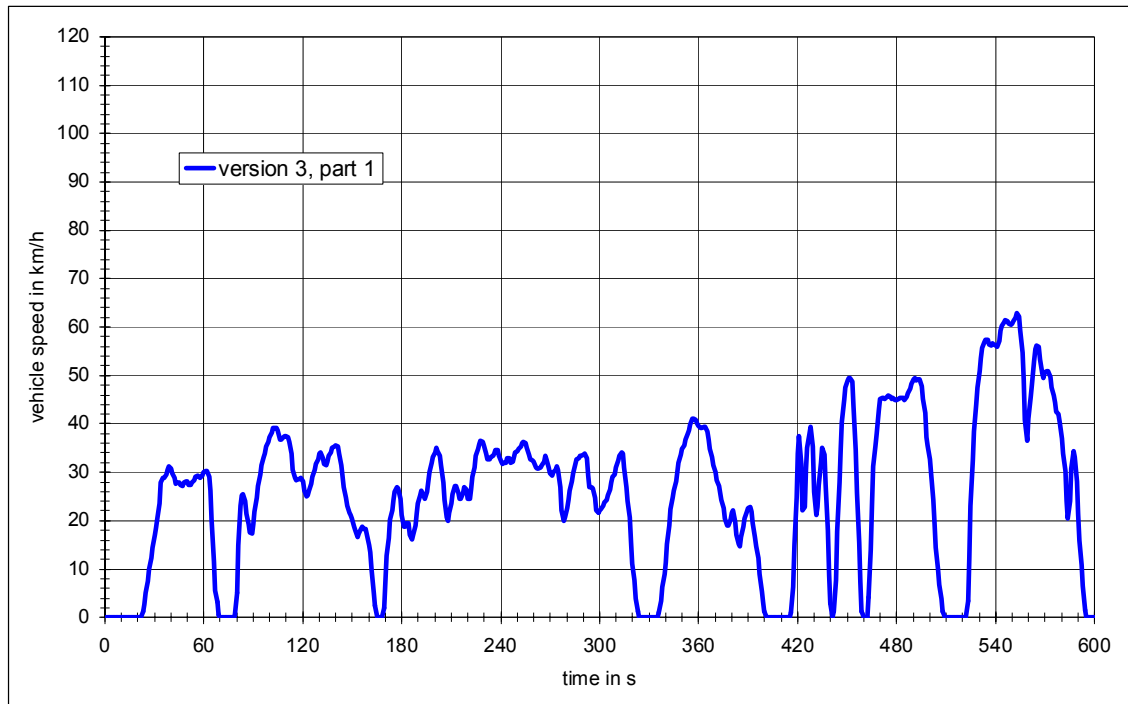

Figure 15: Cycle version 3, part 1

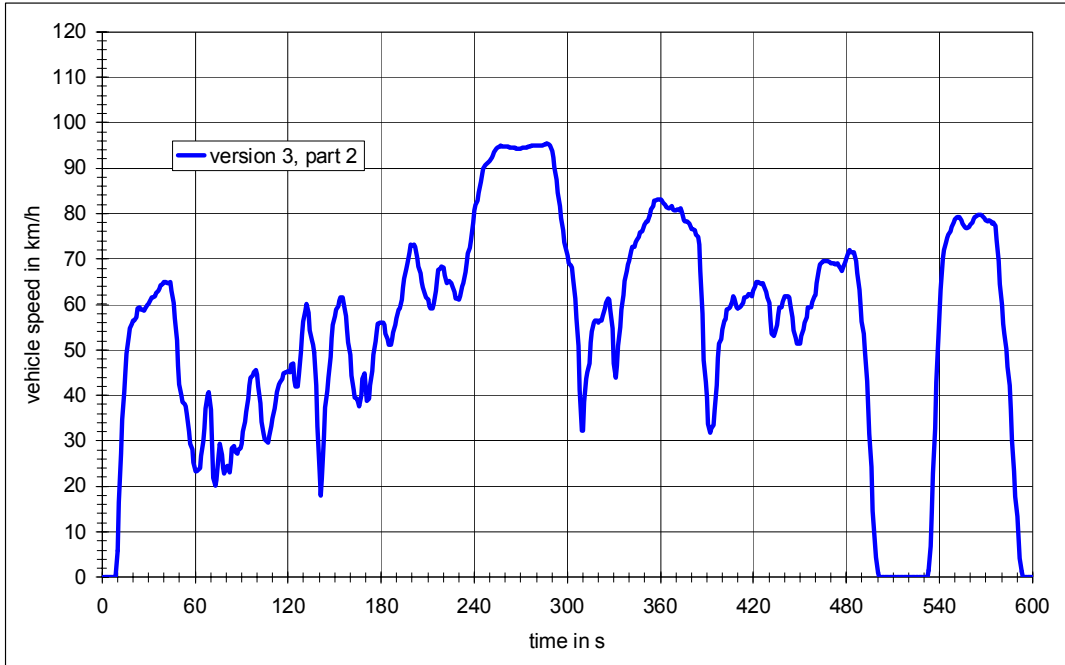

Figure 16: Cycle version 3, part 2

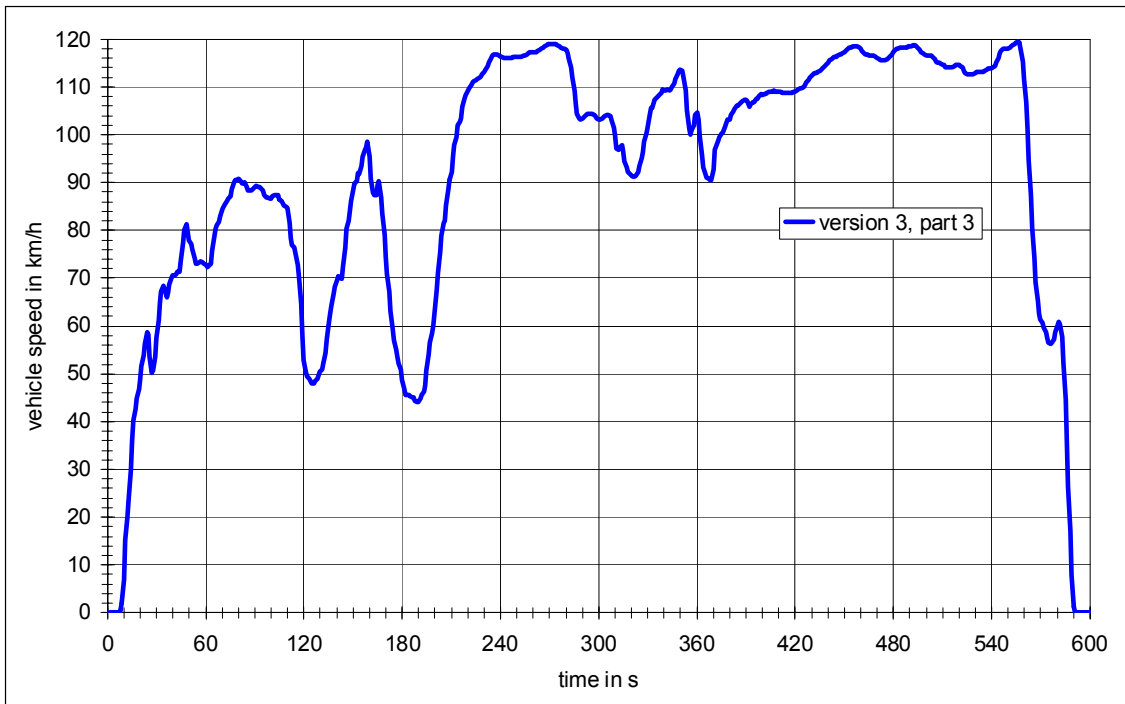

Figure 17: Cycle version 3, part 3

RWTÜV Fahrzeug carried out further modifications on the basis of discussions and decisions in the WMTC group.

The following modifications were done in a second step:

Part 1:

- Modules 2, 3 and 5 of part 1 were replaced by more representative ones (length, average speed and dynamics were kept),
- The rank order of the modules was changed (module 8 was shifted to the 2nd position),
- The top speed of module 8 was limited to 60 km/h,
- The idle time distribution was brought in line with the statistics.

Part 3:

- The top speed was increased to 125 km/h.

These modifications resulted in version 4.

Furthermore an analysis of the acceleration pattern showed unrealistic “jumps” in some cycle phases. Smoothing the acceleration pattern and recalculating the vehicle speed pattern from the smoothed acceleration pattern eliminated these „jumps“. This results in version 5. Version 5 was used for the driveability validation tests and is shown in Figure 18 to Figure 20.

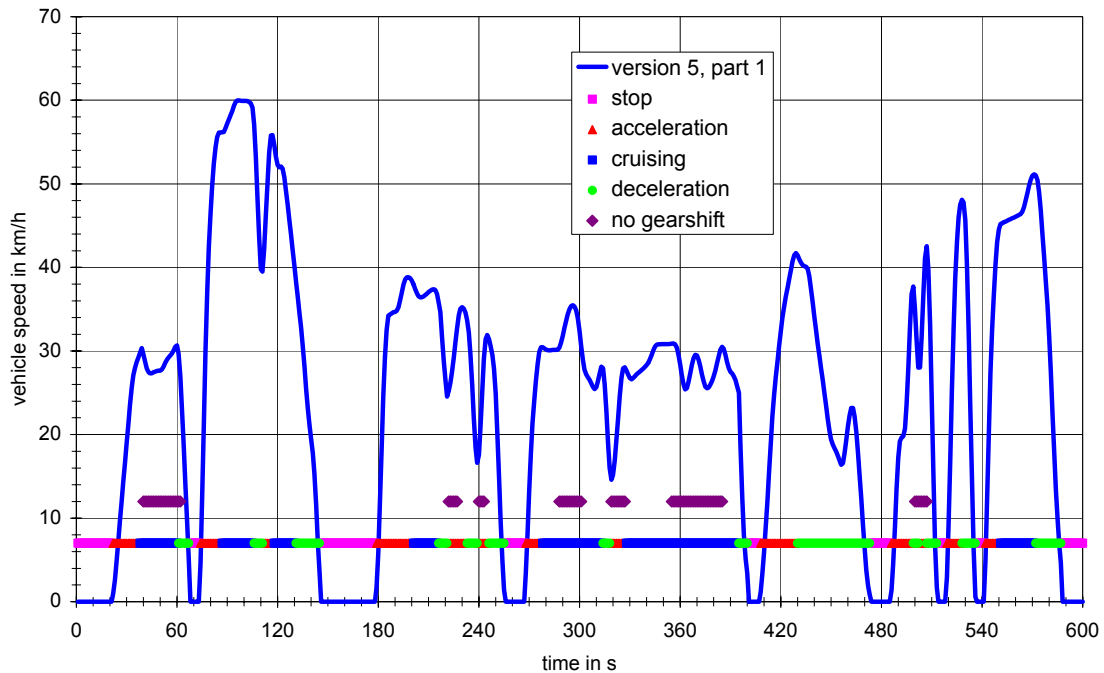

Figure 18: Cycle version 5, part 1

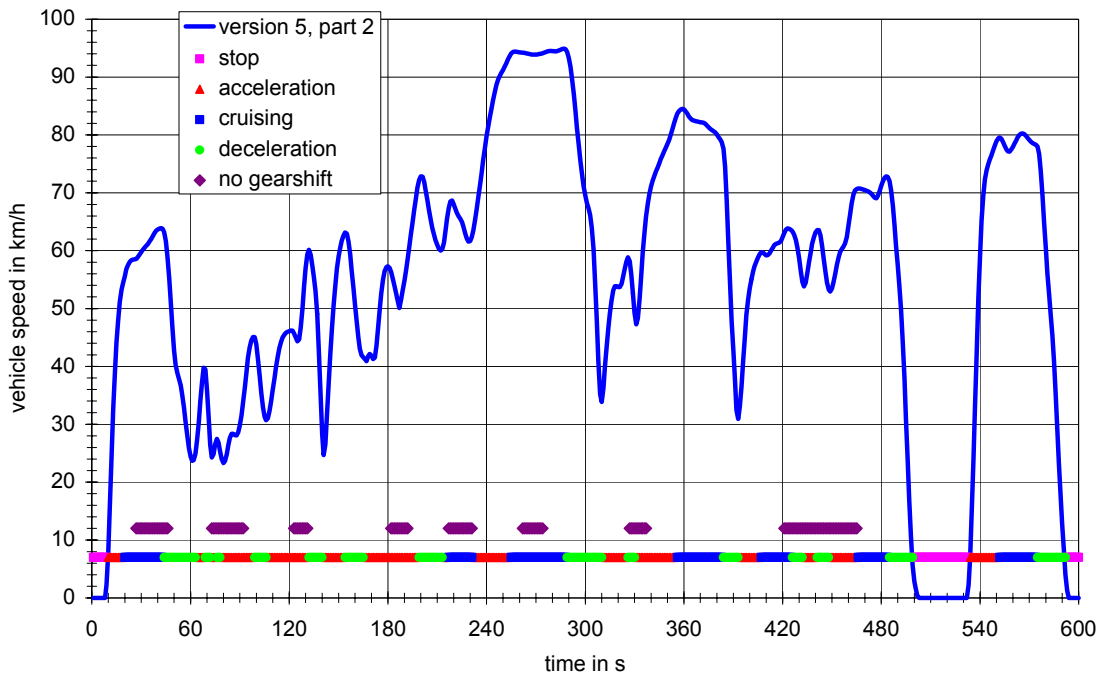

Figure 19: Cycle version 5, part 2

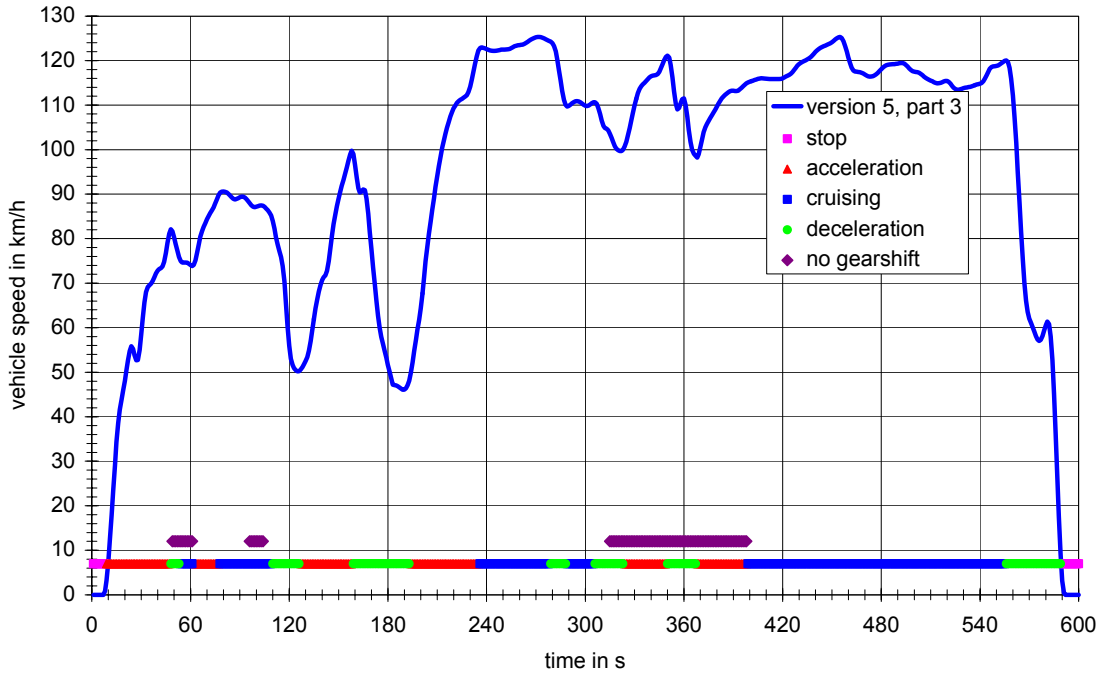

Figure 20: Cycle version 5, part 3

Since vehicle speed pattern and gearshift procedure are closely linked, the elimination of malfunctions in the gearshift procedure resulted in cycle version 6.

As an outcome of the driveability validation tests the following modifications led to version 7 which is now the basis for the emissions validation:

In part 1 the modules 2 and 3 were exchanged to get a more realistic pattern for the cold start phase.

To reduce the risk of wheel lock cycle phases with excessive decelerations were modified so that the following limitations are fulfilled:

- vehicle acceleration $\leq -2\text{m/s}^2$
- acceleration * vehicle speed $\leq -30\text{ m}^2/\text{s}^3$

The second criterion (acceleration*vehicle speed) was necessary because there were still some sections in the cycles with acceleration values above -2 m/s^2 that caused wheel lock in some cases. The modified cycles (version 7) are shown in Figure 21 to Figure 23.

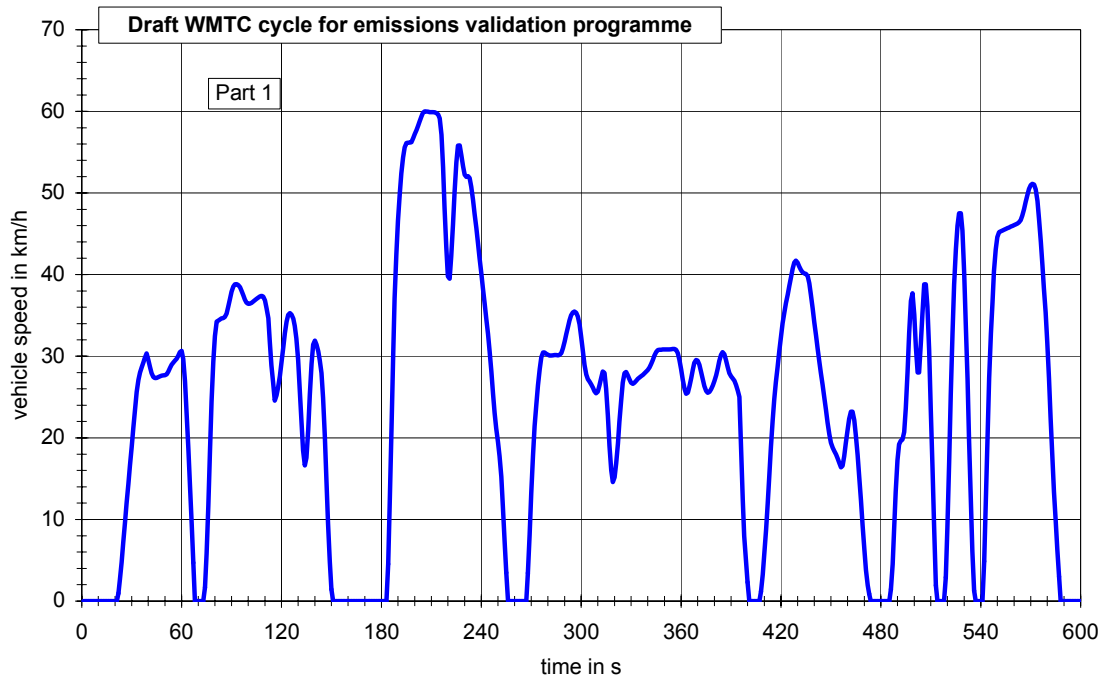

Figure 21: Cycle version 7, part 1

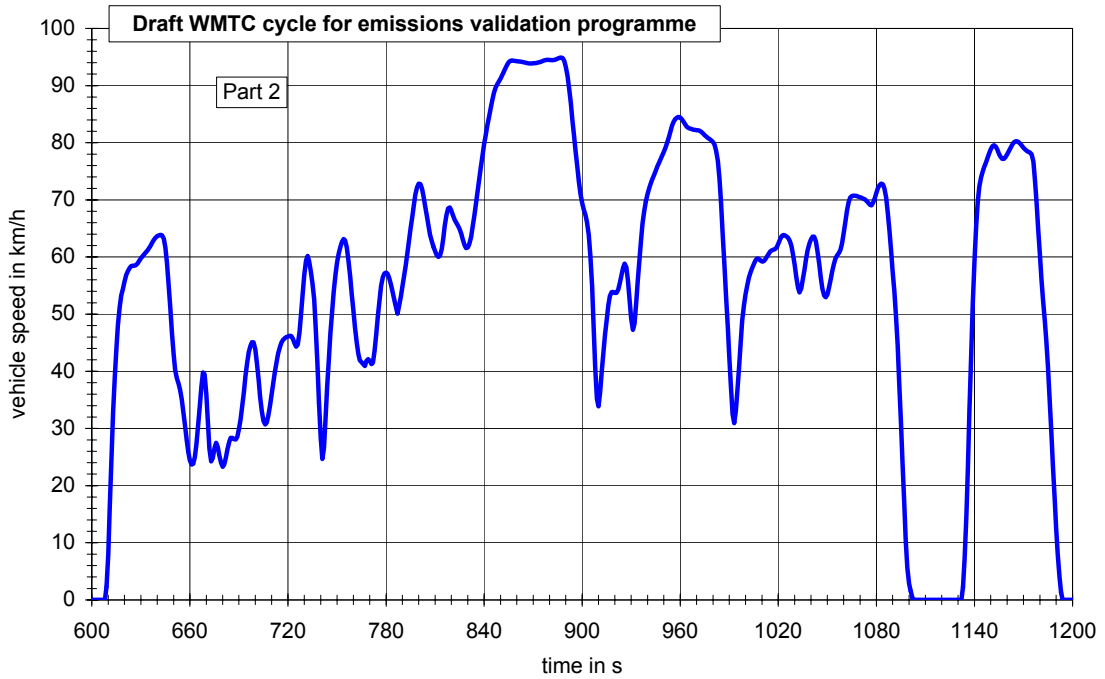

Figure 22: Cycle version 7, part 2

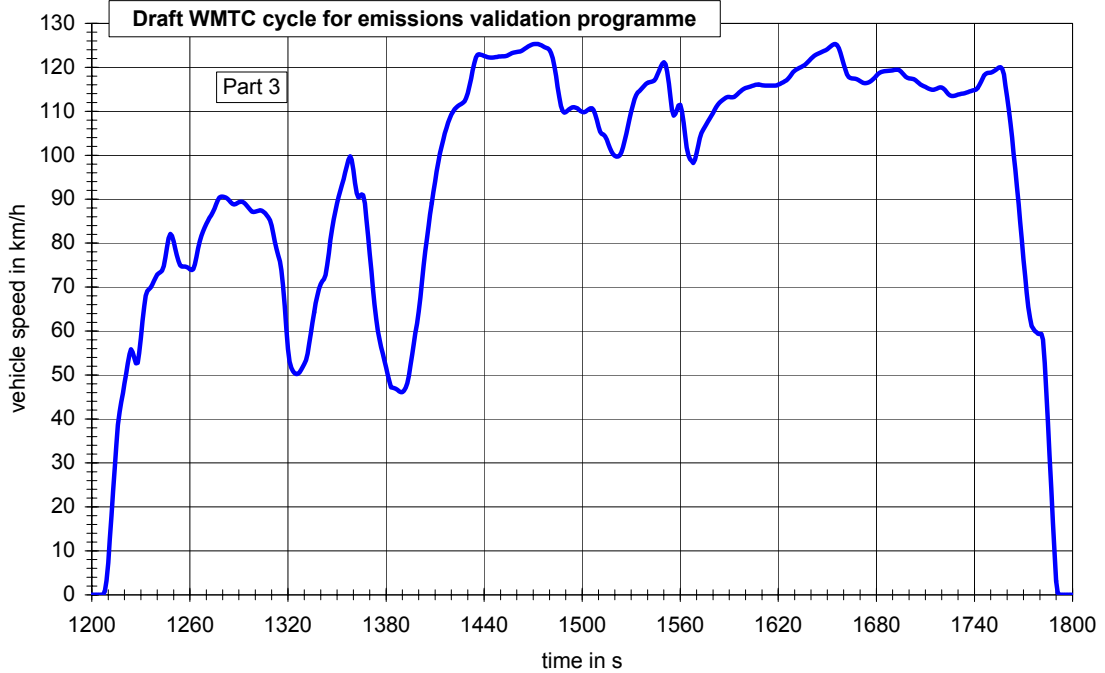

Figure 23: Cycle version 7, part 3

Although the results of a detailed analysis of the tyre slip phenomenon showed that the dynamics of the WMTC do not cause higher risks for tyre slip than existing certification cycles it

was decided in the WMTC group that this risk should be minimised for the WMTC to improve driveability, independent of the situation for existing cycles.

A renewed analysis showed that the transitions from standstill to ride and vice versa become smooth enough if da/dt is between $-0.8 \text{ m/s}^2/\text{s}$ and $+0.8 \text{ m/s}^2/\text{s}$. Consequently the vehicle speed pattern were modified until da/dt falls into that range.

Since it is logical to apply the same criterion also for phases in ride condition where da/dt is outside this range (in cases where a deceleration is immediately followed by an acceleration and vice versa), these cycle phases were modified accordingly.

The results are shown in the following figures.

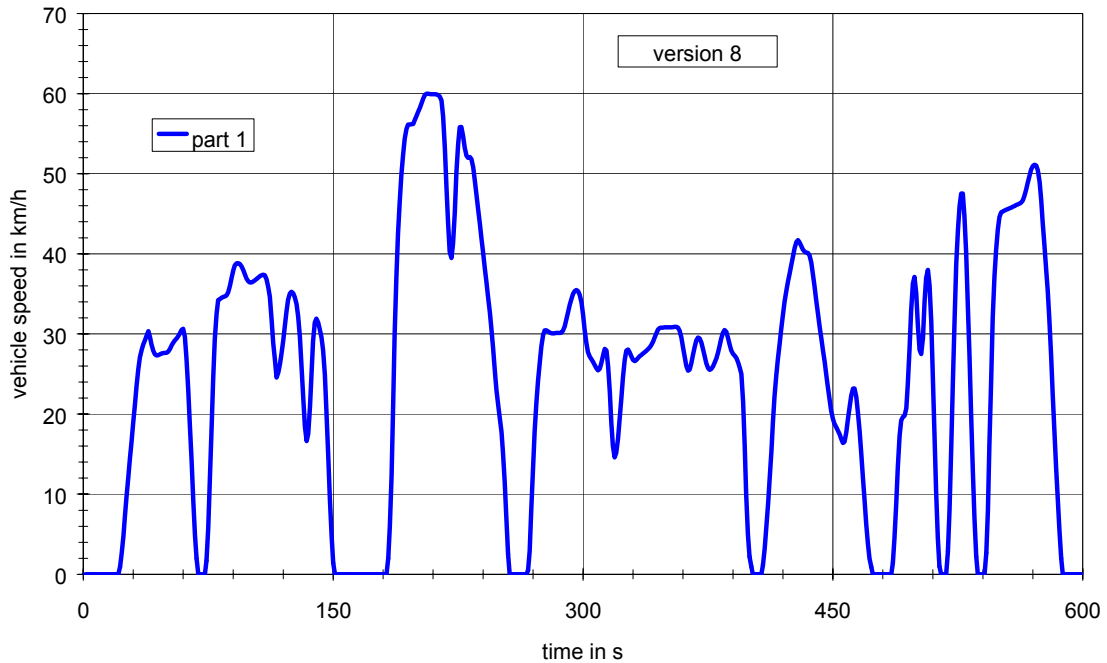

Figure 24: Cycle version 8, part 1

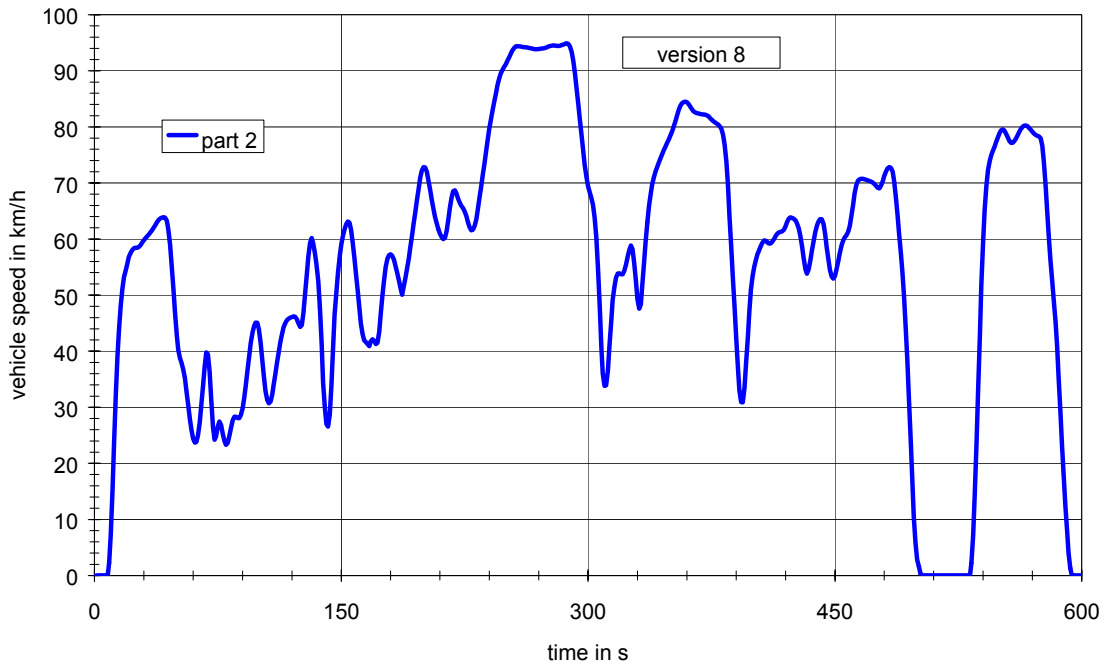

Figure 25: Cycle version 8, part 2

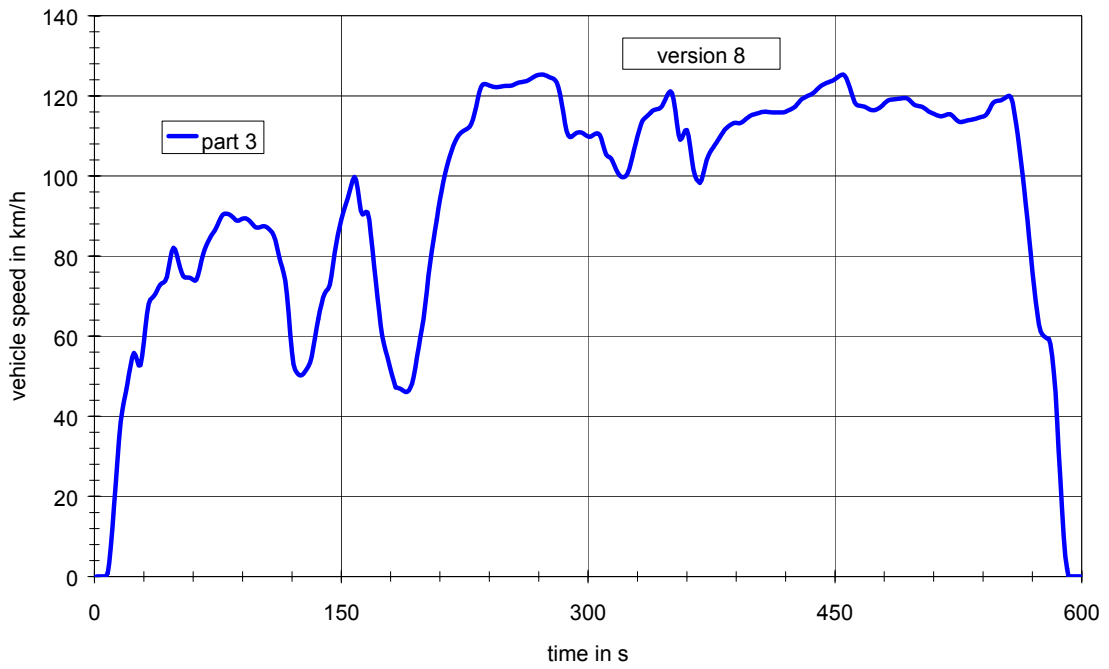

Figure 26: Cycle version 8, part 3

During the WMTC FE meeting in Tokyo in April 2002 the Japanese delegation requested a special version of part 1 with a top speed of 50 km/h for low powered motorcycles whose technical specifications are close to mopeds.

Since there is only one module in part 1 with vehicle speeds above 50 km/h (module 3), only this module was modified. The first part was replaced by a module taken from in-use measurements of vehicle 6 (this module was closest to the existing one) and the second part was lowered in speed to fulfil the limitation of 50 km/h.

The result is shown in the following figure.

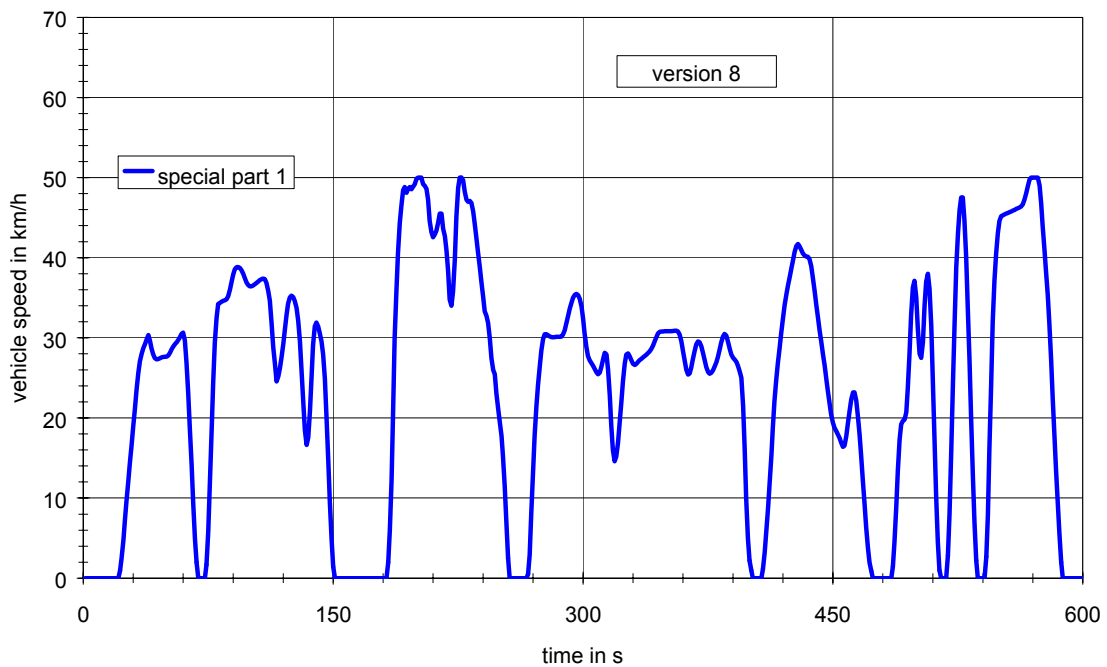

Figure 27: Cycle version 8, part 1, reduced speed, with top speed limited to 50 km/h for low powered motorcycles with 50 cm³ engine capacity whose technical specifications are close to mopeds

Annex B – Final Cycle Version

Part	version	time in s	v in km/h	time in s	v in km/h	time in s	v in km/h	time in s	v in km/h	time in s	v in km/h
1	8	1	0.0	61	29.7	121	31.0	181	0.0	241	38.3
1	8	2	0.0	62	26.9	122	32.8	182	0.0	242	36.4
1	8	3	0.0	63	23.0	123	34.3	183	2.0	243	34.6
1	8	4	0.0	64	18.7	124	35.1	184	6.0	244	32.7
1	8	5	0.0	65	14.2	125	35.3	185	12.4	245	30.6
1	8	6	0.0	66	9.4	126	35.1	186	21.4	246	28.1
1	8	7	0.0	67	4.9	127	34.6	187	30.0	247	25.4
1	8	8	0.0	68	2.0	128	33.7	188	37.1	248	23.1
1	8	9	0.0	69	0.0	129	32.2	189	42.5	249	21.2
1	8	10	0.0	70	0.0	130	29.6	190	46.6	250	19.5
1	8	11	0.0	71	0.0	131	26.0	191	49.8	251	17.8
1	8	12	0.0	72	0.0	132	22.0	192	52.4	252	15.2
1	8	13	0.0	73	0.0	133	18.5	193	54.4	253	11.5
1	8	14	0.0	74	1.7	134	16.6	194	55.6	254	7.2
1	8	15	0.0	75	5.8	135	17.5	195	56.1	255	2.5
1	8	16	0.0	76	11.8	136	20.9	196	56.2	256	0.0
1	8	17	0.0	77	18.3	137	25.2	197	56.2	257	0.0
1	8	18	0.0	78	24.5	138	29.1	198	56.2	258	0.0
1	8	19	0.0	79	29.4	139	31.4	199	56.7	259	0.0
1	8	20	0.0	80	32.5	140	31.9	200	57.2	260	0.0
1	8	21	0.0	81	34.2	141	31.4	201	57.7	261	0.0
1	8	22	1.0	82	34.4	142	30.6	202	58.2	262	0.0
1	8	23	2.6	83	34.5	143	29.5	203	58.7	263	0.0
1	8	24	4.8	84	34.6	144	27.9	204	59.3	264	0.0
1	8	25	7.2	85	34.7	145	24.9	205	59.8	265	0.0
1	8	26	9.6	86	34.8	146	20.2	206	60.0	266	0.0
1	8	27	12.0	87	35.2	147	14.8	207	60.0	267	0.5
1	8	28	14.3	88	36.0	148	9.5	208	59.9	268	2.9
1	8	29	16.6	89	37.0	149	4.8	209	59.9	269	8.2
1	8	30	18.9	90	37.9	150	1.4	210	59.9	270	13.2
1	8	31	21.2	91	38.5	151	0.0	211	59.9	271	17.8
1	8	32	23.5	92	38.8	152	0.0	212	59.9	272	21.4
1	8	33	25.6	93	38.8	153	0.0	213	59.8	273	24.1
1	8	34	27.1	94	38.7	154	0.0	214	59.6	274	26.4
1	8	35	28.0	95	38.4	155	0.0	215	59.1	275	28.4
1	8	36	28.7	96	38.0	156	0.0	216	57.1	276	29.9
1	8	37	29.2	97	37.4	157	0.0	217	53.2	277	30.4
1	8	38	29.8	98	36.9	158	0.0	218	48.3	278	30.5
1	8	39	30.3	99	36.6	159	0.0	219	43.9	279	30.3
1	8	40	29.6	100	36.4	160	0.0	220	40.3	280	30.2
1	8	41	28.7	101	36.4	161	0.0	221	39.5	281	30.1
1	8	42	27.9	102	36.5	162	0.0	222	41.3	282	30.1
1	8	43	27.5	103	36.7	163	0.0	223	45.2	283	30.1
1	8	44	27.3	104	36.9	164	0.0	224	50.1	284	30.1
1	8	45	27.3	105	37.0	165	0.0	225	53.7	285	30.1
1	8	46	27.4	106	37.2	166	0.0	226	55.8	286	30.1
1	8	47	27.5	107	37.3	167	0.0	227	55.8	287	30.2
1	8	48	27.6	108	37.4	168	0.0	228	54.7	288	30.4
1	8	49	27.6	109	37.3	169	0.0	229	53.3	289	31.0
1	8	50	27.7	110	36.8	170	0.0	230	52.2	290	31.8
1	8	51	27.8	111	35.8	171	0.0	231	52.0	291	32.7
1	8	52	28.1	112	34.6	172	0.0	232	52.1	292	33.6
1	8	53	28.6	113	31.8	173	0.0	233	51.8	293	34.4
1	8	54	28.9	114	28.9	174	0.0	234	50.8	294	35.0
1	8	55	29.2	115	26.7	175	0.0	235	49.2	295	35.4
1	8	56	29.4	116	24.6	176	0.0	236	47.4	296	35.5
1	8	57	29.7	117	25.2	177	0.0	237	45.7	297	35.3
1	8	58	30.1	118	26.2	178	0.0	238	43.9	298	34.9
1	8	59	30.5	119	27.5	179	0.0	239	42.0	299	33.9
1	8	60	30.7	120	29.2	180	0.0	240	40.2	300	32.4

Table 25: WMTC, part 1, version 8, 1 to 300 s

Worldwide Harmonised Motorcycle Emissions Certification Procedure, Draft Technical Report

Part	version	time in s	v in km/h	time in s	v in km/h	time in s	v in km/h	time in s	v in km/h	time in s	v in km/h
1	8	301	30.6	361	27.1	421	34.0	481	0.0	541	0.0
1	8	302	28.9	362	26.0	422	35.4	482	0.0	542	2.7
1	8	303	27.8	363	25.4	423	36.5	483	0.0	543	8.0
1	8	304	27.2	364	25.5	424	37.5	484	0.0	544	16.0
1	8	305	26.9	365	26.3	425	38.6	485	0.0	545	24.0
1	8	306	26.5	366	27.3	426	39.7	486	1.4	546	32.0
1	8	307	26.1	367	28.4	427	40.7	487	4.5	547	37.2
1	8	308	25.7	368	29.2	428	41.5	488	8.8	548	40.4
1	8	309	25.5	369	29.5	429	41.7	489	13.4	549	43.0
1	8	310	25.7	370	29.4	430	41.5	490	17.3	550	44.6
1	8	311	26.4	371	28.9	431	41.0	491	19.2	551	45.2
1	8	312	27.3	372	28.1	432	40.6	492	19.7	552	45.3
1	8	313	28.1	373	27.2	433	40.3	493	19.8	553	45.4
1	8	314	27.9	374	26.3	434	40.1	494	20.7	554	45.5
1	8	315	26.0	375	25.7	435	40.1	495	23.6	555	45.6
1	8	316	22.7	376	25.5	436	39.8	496	28.1	556	45.7
1	8	317	19.0	377	25.6	437	38.9	497	32.8	557	45.8
1	8	318	16.0	378	26.0	438	37.5	498	36.3	558	45.9
1	8	319	14.6	379	26.4	439	35.8	499	37.1	559	46.0
1	8	320	15.2	380	27.0	440	34.2	500	35.1	560	46.1
1	8	321	16.9	381	27.7	441	32.5	501	31.1	561	46.2
1	8	322	19.3	382	28.5	442	30.9	502	28.0	562	46.3
1	8	323	22.0	383	29.4	443	29.4	503	27.5	563	46.4
1	8	324	24.6	384	30.2	444	28.0	504	29.5	564	46.7
1	8	325	26.8	385	30.5	445	26.5	505	34.0	565	47.2
1	8	326	27.9	386	30.3	446	25.0	506	37.0	566	48.0
1	8	327	28.1	387	29.5	447	23.4	507	38.0	567	48.9
1	8	328	27.7	388	28.7	448	21.9	508	36.1	568	49.8
1	8	329	27.2	389	27.9	449	20.4	509	31.5	569	50.5
1	8	330	26.7	390	27.5	450	19.4	510	24.5	570	51.0
1	8	331	26.6	391	27.3	451	18.8	511	17.5	571	51.1
1	8	332	26.8	392	27.0	452	18.4	512	10.5	572	51.0
1	8	333	27.0	393	26.5	453	18.0	513	4.5	573	50.4
1	8	334	27.2	394	25.8	454	17.5	514	1.0	574	49.0
1	8	335	27.4	395	25.0	455	16.9	515	0.0	575	46.7
1	8	336	27.5	396	21.5	456	16.4	516	0.0	576	44.0
1	8	337	27.7	397	16.0	457	16.6	517	0.0	577	41.1
1	8	338	27.9	398	10.0	458	17.7	518	0.0	578	38.3
1	8	339	28.1	399	5.0	459	19.3	519	2.9	579	35.4
1	8	340	28.3	400	2.2	460	20.9	520	8.0	580	31.8
1	8	341	28.6	401	1.0	461	22.3	521	16.0	581	27.3
1	8	342	29.0	402	0.0	462	23.2	522	24.0	582	22.4
1	8	343	29.5	403	0.0	463	23.2	523	32.0	583	17.7
1	8	344	30.1	404	0.0	464	22.2	524	38.8	584	13.4
1	8	345	30.5	405	0.0	465	20.3	525	43.1	585	9.3
1	8	346	30.7	406	0.0	466	17.9	526	46.0	586	5.5
1	8	347	30.8	407	0.0	467	15.2	527	47.5	587	2.0
1	8	348	30.8	408	1.2	468	12.3	528	47.5	588	0.0
1	8	349	30.8	409	3.2	469	9.3	529	44.8	589	0.0
1	8	350	30.8	410	5.9	470	6.4	530	40.1	590	0.0
1	8	351	30.8	411	8.8	471	3.8	531	33.8	591	0.0
1	8	352	30.8	412	12.0	472	1.9	532	27.2	592	0.0
1	8	353	30.8	413	15.4	473	0.9	533	20.0	593	0.0
1	8	354	30.9	414	18.9	474	0.0	534	12.8	594	0.0
1	8	355	30.9	415	22.1	475	0.0	535	7.0	595	0.0
1	8	356	30.9	416	24.7	476	0.0	536	2.2	596	0.0
1	8	357	30.8	417	26.8	477	0.0	537	0.0	597	0.0
1	8	358	30.4	418	28.7	478	0.0	538	0.0	598	0.0
1	8	359	29.6	419	30.6	479	0.0	539	0.0	599	0.0
1	8	360	28.4	420	32.4	480	0.0	540	0.0	600	0.0

Table 26: WMTC, part 1, version 8, 301 to 600 s

Worldwide Harmonised Motorcycle Emissions Certification Procedure, Draft Technical Report

Part	version	time in s	v in km/h	time in s	v in km/h	time in s	v in km/h	time in s	v in km/h	time in s	v in km/h
2	8	1	0.0	61	23.7	121	46.2	181	57.0	241	81.5
2	8	2	0.0	62	23.8	122	46.1	182	56.3	242	83.0
2	8	3	0.0	63	25.0	123	45.7	183	55.2	243	84.5
2	8	4	0.0	64	27.3	124	45.0	184	53.9	244	86.0
2	8	5	0.0	65	30.4	125	44.3	185	52.6	245	87.4
2	8	6	0.0	66	33.9	126	44.7	186	51.3	246	88.7
2	8	7	0.0	67	37.3	127	46.8	187	50.1	247	89.6
2	8	8	0.0	68	39.8	128	50.1	188	51.5	248	90.2
2	8	9	2.3	69	39.5	129	53.6	189	53.1	249	90.7
2	8	10	7.3	70	36.3	130	56.9	190	54.8	250	91.2
2	8	11	15.2	71	31.4	131	59.4	191	56.6	251	91.8
2	8	12	23.9	72	26.5	132	60.2	192	58.5	252	92.4
2	8	13	32.5	73	24.2	133	59.3	193	60.6	253	93.0
2	8	14	39.2	74	24.8	134	57.5	194	62.8	254	93.6
2	8	15	44.1	75	26.6	135	55.4	195	64.9	255	94.1
2	8	16	48.1	76	27.5	136	52.5	196	67.0	256	94.3
2	8	17	51.2	77	26.8	137	47.9	197	69.1	257	94.4
2	8	18	53.3	78	25.3	138	41.4	198	70.9	258	94.4
2	8	19	54.5	79	24.0	139	34.4	199	72.2	259	94.3
2	8	20	55.7	80	23.3	140	30.0	200	72.8	260	94.3
2	8	21	56.8	81	23.7	141	27.0	201	72.8	261	94.2
2	8	22	57.5	82	24.9	142	26.5	202	71.9	262	94.2
2	8	23	58.0	83	26.4	143	28.7	203	70.5	263	94.2
2	8	24	58.4	84	27.7	144	33.8	204	68.8	264	94.1
2	8	25	58.5	85	28.3	145	40.3	205	67.1	265	94.0
2	8	26	58.5	86	28.3	146	46.6	206	65.4	266	94.0
2	8	27	58.6	87	28.1	147	50.4	207	63.9	267	93.9
2	8	28	58.9	88	28.1	148	53.9	208	62.7	268	93.9
2	8	29	59.3	89	28.6	149	56.9	209	61.8	269	93.9
2	8	30	59.8	90	29.8	150	59.1	210	61.0	270	93.9
2	8	31	60.2	91	31.6	151	60.6	211	60.4	271	93.9
2	8	32	60.5	92	33.9	152	61.7	212	60.0	272	94.0
2	8	33	60.8	93	36.5	153	62.6	213	60.2	273	94.0
2	8	34	61.1	94	39.1	154	63.1	214	61.4	274	94.1
2	8	35	61.5	95	41.5	155	62.9	215	63.3	275	94.2
2	8	36	62.0	96	43.3	156	61.6	216	65.5	276	94.3
2	8	37	62.5	97	44.5	157	59.4	217	67.4	277	94.4
2	8	38	63.0	98	45.1	158	56.6	218	68.5	278	94.5
2	8	39	63.4	99	45.1	159	53.7	219	68.7	279	94.5
2	8	40	63.7	100	43.9	160	50.7	220	68.1	280	94.5
2	8	41	63.8	101	41.4	161	47.7	221	67.2	281	94.5
2	8	42	63.9	102	38.4	162	45.0	222	66.5	282	94.4
2	8	43	63.8	103	35.5	163	43.0	223	65.9	283	94.5
2	8	44	63.2	104	32.9	164	41.9	224	65.5	284	94.6
2	8	45	61.7	105	31.3	165	41.6	225	64.9	285	94.7
2	8	46	58.9	106	30.7	166	41.3	226	64.1	286	94.8
2	8	47	55.2	107	31.0	167	40.9	227	63.0	287	94.9
2	8	48	51.0	108	32.2	168	41.8	228	62.1	288	94.8
2	8	49	46.7	109	34.0	169	42.1	229	61.6	289	94.3
2	8	50	42.8	110	36.0	170	41.8	230	61.7	290	93.3
2	8	51	40.2	111	37.9	171	41.3	231	62.3	291	91.7
2	8	52	38.8	112	39.8	172	41.5	232	63.5	292	89.6
2	8	53	37.9	113	41.6	173	43.5	233	65.3	293	87.0
2	8	54	36.7	114	43.1	174	46.5	234	67.3	294	84.1
2	8	55	35.1	115	44.3	175	49.7	235	69.3	295	81.2
2	8	56	32.9	116	45.0	176	52.6	236	71.4	296	78.4
2	8	57	30.4	117	45.5	177	55.0	237	73.5	297	75.7
2	8	58	28.0	118	45.8	178	56.5	238	75.6	298	73.2
2	8	59	25.9	119	46.0	179	57.1	239	77.7	299	71.1
2	8	60	24.4	120	46.1	180	57.3	240	79.7	300	69.5

Table 27: WMTC, part 2, version 8, 1 to 300 s

Worldwide Harmonised Motorcycle Emissions Certification Procedure, Draft Technical Report

Part	version	time in s	v in km/h	time in s	v in km/h	time in s	v in km/h	time in s	v in km/h	time in s	v in km/h
2	8	301	68.3	361	84.1	421	63.0	481	72.0	541	65.3
2	8	302	67.3	362	83.7	422	63.6	482	72.6	542	69.6
2	8	303	66.1	363	83.2	423	63.9	483	72.8	543	72.3
2	8	304	63.9	364	82.8	424	63.8	484	72.7	544	73.9
2	8	305	60.2	365	82.6	425	63.6	485	72.0	545	75.0
2	8	306	54.9	366	82.5	426	63.3	486	70.3	546	75.7
2	8	307	48.1	367	82.4	427	62.8	487	67.7	547	76.5
2	8	308	40.9	368	82.3	428	61.9	488	64.4	548	77.3
2	8	309	36.0	369	82.2	429	60.5	489	61.0	549	78.2
2	8	310	33.9	370	82.2	430	58.6	490	57.6	550	78.9
2	8	311	33.9	371	82.2	431	56.5	491	54.0	551	79.4
2	8	312	36.5	372	82.1	432	54.6	492	49.7	552	79.6
2	8	313	41.0	373	81.9	433	53.8	493	44.4	553	79.3
2	8	314	45.3	374	81.6	434	54.5	494	38.2	554	78.8
2	8	315	49.2	375	81.3	435	56.1	495	31.2	555	78.1
2	8	316	51.5	376	81.1	436	57.9	496	24.0	556	77.5
2	8	317	53.2	377	80.8	437	59.6	497	16.8	557	77.2
2	8	318	53.9	378	80.6	438	61.2	498	10.4	558	77.2
2	8	319	53.9	379	80.4	439	62.3	499	5.7	559	77.5
2	8	320	53.7	380	80.1	440	63.1	500	2.8	560	77.9
2	8	321	53.7	381	79.7	441	63.6	501	1.6	561	78.5
2	8	322	54.3	382	78.6	442	63.5	502	0.3	562	79.1
2	8	323	55.4	383	76.8	443	62.7	503	0.0	563	79.6
2	8	324	56.8	384	73.7	444	60.9	504	0.0	564	80.0
2	8	325	58.1	385	69.4	445	58.7	505	0.0	565	80.2
2	8	326	58.8	386	64.0	446	56.4	506	0.0	566	80.3
2	8	327	58.2	387	58.6	447	54.5	507	0.0	567	80.1
2	8	328	55.8	388	53.2	448	53.3	508	0.0	568	79.8
2	8	329	52.6	389	47.8	449	53.0	509	0.0	569	79.5
2	8	330	49.2	390	42.4	450	53.5	510	0.0	570	79.1
2	8	331	47.6	391	37.0	451	54.6	511	0.0	571	78.8
2	8	332	48.4	392	33.0	452	56.1	512	0.0	572	78.6
2	8	333	51.8	393	30.9	453	57.6	513	0.0	573	78.4
2	8	334	55.7	394	30.9	454	58.9	514	0.0	574	78.3
2	8	335	59.6	395	33.5	455	59.8	515	0.0	575	78.0
2	8	336	63.0	396	38.0	456	60.3	516	0.0	576	76.7
2	8	337	65.9	397	42.5	457	60.7	517	0.0	577	73.7
2	8	338	68.1	398	47.0	458	61.3	518	0.0	578	69.5
2	8	339	69.8	399	51.0	459	62.3	519	0.0	579	64.8
2	8	340	71.1	400	53.5	460	64.1	520	0.0	580	60.3
2	8	341	72.1	401	55.1	461	66.2	521	0.0	581	56.2
2	8	342	72.9	402	56.4	462	68.1	522	0.0	582	52.5
2	8	343	73.7	403	57.3	463	69.7	523	0.0	583	49.0
2	8	344	74.4	404	58.1	464	70.4	524	0.0	584	45.2
2	8	345	75.1	405	58.8	465	70.7	525	0.0	585	40.8
2	8	346	75.8	406	59.4	466	70.7	526	0.0	586	35.4
2	8	347	76.5	407	59.8	467	70.7	527	0.0	587	29.4
2	8	348	77.2	408	59.7	468	70.7	528	0.0	588	23.4
2	8	349	77.8	409	59.4	469	70.6	529	0.0	589	17.7
2	8	350	78.5	410	59.2	470	70.5	530	0.0	590	12.6
2	8	351	79.2	411	59.2	471	70.3	531	0.0	591	8.0
2	8	352	80.0	412	59.5	472	70.2	532	0.0	592	4.1
2	8	353	81.0	413	60.0	473	70.1	533	2.3	593	1.3
2	8	354	82.0	414	60.5	474	69.8	534	7.2	594	0.0
2	8	355	82.9	415	61.0	475	69.5	535	14.6	595	0.0
2	8	356	83.7	416	61.2	476	69.1	536	23.5	596	0.0
2	8	357	84.2	417	61.3	477	69.1	537	33.0	597	0.0
2	8	358	84.4	418	61.4	478	69.5	538	42.7	598	0.0
2	8	359	84.5	419	61.7	479	70.3	539	51.8	599	0.0
2	8	360	84.4	420	62.3	480	71.2	540	59.4	600	0.0

Table 28: WMTC, part 2, version 8, 301 to 600 s

Worldwide Harmonised Motorcycle Emissions Certification Procedure, Draft Technical Report

Part	version	time in s	v in km/h	time in s	v in km/h	time in s	v in km/h	time in s	v in km/h	time in s	v in km/h
3	8	1	0.0	61	73.9	121	53.0	181	50.2	241	122.4
3	8	2	0.0	62	74.1	122	51.6	182	48.7	242	122.3
3	8	3	0.0	63	75.1	123	50.9	183	47.2	243	122.2
3	8	4	0.0	64	76.8	124	50.5	184	47.1	244	122.2
3	8	5	0.0	65	78.7	125	50.2	185	47.0	245	122.2
3	8	6	0.0	66	80.4	126	50.2	186	46.9	246	122.2
3	8	7	0.0	67	81.7	127	50.6	187	46.6	247	122.3
3	8	8	0.9	68	82.6	128	51.2	188	46.3	248	122.4
3	8	9	3.2	69	83.5	129	51.8	189	46.1	249	122.4
3	8	10	7.3	70	84.4	130	52.5	190	46.1	250	122.5
3	8	11	12.4	71	85.1	131	53.4	191	46.4	251	122.5
3	8	12	17.9	72	85.7	132	54.9	192	47.1	252	122.5
3	8	13	23.5	73	86.3	133	57.0	193	48.1	253	122.5
3	8	14	29.1	74	87.0	134	59.4	194	49.8	254	122.6
3	8	15	34.3	75	87.9	135	61.9	195	52.2	255	122.8
3	8	16	38.6	76	88.8	136	64.3	196	54.8	256	123.0
3	8	17	41.6	77	89.7	137	66.4	197	57.3	257	123.2
3	8	18	43.9	78	90.3	138	68.1	198	59.5	258	123.3
3	8	19	45.9	79	90.6	139	69.6	199	61.7	259	123.4
3	8	20	48.1	80	90.6	140	70.7	200	64.3	260	123.5
3	8	21	50.3	81	90.5	141	71.4	201	67.7	261	123.5
3	8	22	52.6	82	90.4	142	71.8	202	71.4	262	123.6
3	8	23	54.8	83	90.1	143	72.8	203	74.9	263	123.8
3	8	24	55.8	84	89.7	144	75.0	204	78.2	264	124.0
3	8	25	55.2	85	89.3	145	77.8	205	81.1	265	124.2
3	8	26	53.8	86	88.9	146	80.7	206	83.9	266	124.5
3	8	27	52.7	87	88.8	147	83.3	207	86.5	267	124.7
3	8	28	52.8	88	88.9	148	85.4	208	89.1	268	124.9
3	8	29	55.0	89	89.1	149	87.3	209	91.6	269	125.1
3	8	30	58.5	90	89.3	150	89.1	210	94.0	270	125.2
3	8	31	62.3	91	89.4	151	90.6	211	96.3	271	125.3
3	8	32	65.7	92	89.4	152	91.9	212	98.4	272	125.3
3	8	33	68.0	93	89.2	153	93.2	213	100.4	273	125.3
3	8	34	69.1	94	88.9	154	94.5	214	102.1	274	125.2
3	8	35	69.5	95	88.5	155	96.0	215	103.6	275	125.0
3	8	36	69.9	96	88.0	156	97.5	216	104.9	276	124.8
3	8	37	70.6	97	87.5	157	98.9	217	106.2	277	124.6
3	8	38	71.3	98	87.2	158	99.8	218	107.4	278	124.4
3	8	39	72.2	99	87.1	159	99.0	219	108.5	279	124.3
3	8	40	72.8	100	87.2	160	96.6	220	109.3	280	123.9
3	8	41	73.2	101	87.3	161	93.7	221	109.9	281	123.3
3	8	42	73.4	102	87.4	162	91.3	222	110.5	282	122.1
3	8	43	73.8	103	87.5	163	90.4	223	110.9	283	120.3
3	8	44	74.8	104	87.4	164	90.6	224	111.2	284	118.0
3	8	45	76.7	105	87.1	165	91.1	225	111.4	285	115.5
3	8	46	79.1	106	86.8	166	90.9	226	111.7	286	113.2
3	8	47	81.1	107	86.4	167	89.0	227	111.9	287	111.2
3	8	48	82.1	108	85.9	168	85.6	228	112.3	288	110.1
3	8	49	81.7	109	85.2	169	81.6	229	113.0	289	109.7
3	8	50	80.3	110	84.0	170	77.6	230	114.1	290	109.8
3	8	51	78.8	111	82.2	171	73.6	231	115.7	291	110.1
3	8	52	77.3	112	80.3	172	69.7	232	117.5	292	110.4
3	8	53	75.9	113	78.6	173	66.0	233	119.3	293	110.7
3	8	54	75.0	114	77.2	174	62.7	234	121.0	294	110.9
3	8	55	74.7	115	75.9	175	60.0	235	122.2	295	110.9
3	8	56	74.6	116	73.8	176	58.0	236	122.9	296	110.8
3	8	57	74.7	117	70.4	177	56.4	237	123.0	297	110.6
3	8	58	74.6	118	65.7	178	54.8	238	122.9	298	110.4
3	8	59	74.4	119	60.5	179	53.2	239	122.7	299	110.1
3	8	60	74.1	120	55.9	180	51.7	240	122.6	300	109.9

Table 29: WMTC, part 3, version 8, 1 to 300 s

Worldwide Harmonised Motorcycle Emissions Certification Procedure, Draft Technical Report

Part	version	time in s	v in km/h	time in s	v in km/h	time in s	v in km/h	time in s	v in km/h	time in s	v in km/h
3	8	301	109.8	361	110.1	421	116.2	481	118.5	541	115.0
3	8	302	109.9	362	107.4	422	116.4	482	118.8	542	115.3
3	8	303	110.2	363	104.4	423	116.6	483	118.9	543	116.0
3	8	304	110.4	364	101.8	424	116.8	484	119.1	544	116.7
3	8	305	110.7	365	100.0	425	117.0	485	119.1	545	117.5
3	8	306	110.7	366	99.1	426	117.4	486	119.1	546	118.2
3	8	307	110.3	367	98.7	427	117.9	487	119.2	547	118.6
3	8	308	109.3	368	98.2	428	118.4	488	119.2	548	118.7
3	8	309	108.0	369	99.0	429	118.8	489	119.3	549	118.8
3	8	310	106.5	370	100.5	430	119.2	490	119.3	550	118.8
3	8	311	105.4	371	102.3	431	119.5	491	119.4	551	118.9
3	8	312	104.9	372	103.9	432	119.7	492	119.5	552	119.1
3	8	313	104.7	373	105.0	433	119.9	493	119.5	553	119.4
3	8	314	104.3	374	105.8	434	120.1	494	119.3	554	119.7
3	8	315	103.6	375	106.4	435	120.3	495	119.0	555	119.9
3	8	316	102.6	376	107.1	436	120.5	496	118.6	556	120.0
3	8	317	101.7	377	107.7	437	120.8	497	118.2	557	119.6
3	8	318	100.8	378	108.3	438	121.1	498	117.8	558	118.4
3	8	319	100.2	379	109.0	439	121.5	499	117.6	559	115.9
3	8	320	99.8	380	109.6	440	122.0	500	117.5	560	113.2
3	8	321	99.7	381	110.3	441	122.3	501	117.4	561	110.5
3	8	322	99.7	382	110.9	442	122.6	502	117.4	562	107.2
3	8	323	100.0	383	111.5	443	122.9	503	117.3	563	104.0
3	8	324	100.7	384	112.0	444	123.1	504	117.0	564	100.4
3	8	325	101.8	385	112.3	445	123.2	505	116.7	565	96.8
3	8	326	103.2	386	112.6	446	123.4	506	116.4	566	92.8
3	8	327	104.9	387	112.9	447	123.5	507	116.1	567	88.9
3	8	328	106.6	388	113.1	448	123.7	508	115.9	568	84.9
3	8	329	108.3	389	113.3	449	123.9	509	115.7	569	80.6
3	8	330	109.9	390	113.3	450	124.2	510	115.5	570	76.3
3	8	331	111.4	391	113.2	451	124.4	511	115.3	571	72.3
3	8	332	112.7	392	113.2	452	124.7	512	115.2	572	68.7
3	8	333	113.7	393	113.3	453	125.0	513	115.0	573	65.5
3	8	334	114.3	394	113.5	454	125.2	514	114.9	574	63.0
3	8	335	114.6	395	113.9	455	125.3	515	114.9	575	61.2
3	8	336	115.0	396	114.3	456	125.1	516	115.0	576	60.5
3	8	337	115.4	397	114.6	457	124.4	517	115.2	577	60.0
3	8	338	115.8	398	114.9	458	123.3	518	115.3	578	59.7
3	8	339	116.2	399	115.1	459	122.0	519	115.4	579	59.4
3	8	340	116.5	400	115.3	460	120.8	520	115.4	580	59.4
3	8	341	116.6	401	115.4	461	119.5	521	115.2	581	58.0
3	8	342	116.7	402	115.5	462	118.4	522	114.8	582	55.0
3	8	343	116.8	403	115.6	463	117.8	523	114.4	583	51.0
3	8	344	117.0	404	115.8	464	117.6	524	113.9	584	46.0
3	8	345	117.5	405	115.9	465	117.5	525	113.6	585	38.8
3	8	346	118.3	406	116.0	466	117.5	526	113.5	586	31.6
3	8	347	119.2	407	116.0	467	117.4	527	113.5	587	24.4
3	8	348	120.1	408	116.0	468	117.3	528	113.6	588	17.2
3	8	349	120.8	409	116.0	469	117.1	529	113.7	589	10.0
3	8	350	121.1	410	115.9	470	116.9	530	113.8	590	5.0
3	8	351	120.7	411	115.9	471	116.6	531	113.9	591	2.0
3	8	352	119.0	412	115.9	472	116.5	532	114.0	592	0.0
3	8	353	116.3	413	115.8	473	116.4	533	114.0	593	0.0
3	8	354	113.1	414	115.8	474	116.4	534	114.1	594	0.0
3	8	355	110.3	415	115.8	475	116.5	535	114.2	595	0.0
3	8	356	109.0	416	115.8	476	116.7	536	114.4	596	0.0
3	8	357	109.4	417	115.8	477	117.0	537	114.5	597	0.0
3	8	358	110.4	418	115.8	478	117.3	538	114.6	598	0.0
3	8	359	111.3	419	115.9	479	117.7	539	114.7	599	0.0
3	8	360	111.5	420	116.0	480	118.1	540	114.8	600	0.0

Table 30: WMTC, part 3, version 8, 301 to 600 s

Worldwide Harmonised Motorcycle Emissions Certification Procedure, Draft Technical Report

Part	version	time in s	v in km/h	time in s	v in km/h	time in s	v in km/h	time in s	v in km/h	time in s	v in km/h
1s	8	1	0.0	61	29.7	121	31.0	181	0.0	241	33.3
1s	8	2	0.0	62	26.9	122	32.8	182	0.0	242	32.8
1s	8	3	0.0	63	23.0	123	34.3	183	2.0	243	31.9
1s	8	4	0.0	64	18.7	124	35.1	184	6.0	244	29.9
1s	8	5	0.0	65	14.2	125	35.3	185	12.4	245	27.5
1s	8	6	0.0	66	9.4	126	35.1	186	21.4	246	26.0
1s	8	7	0.0	67	4.9	127	34.6	187	30.0	247	25.4
1s	8	8	0.0	68	2.0	128	33.7	188	35.8	248	23.1
1s	8	9	0.0	69	0.0	129	32.2	189	40.6	249	21.2
1s	8	10	0.0	70	0.0	130	29.6	190	44.3	250	19.5
1s	8	11	0.0	71	0.0	131	26.0	191	46.4	251	17.8
1s	8	12	0.0	72	0.0	132	22.0	192	48.4	252	15.2
1s	8	13	0.0	73	0.0	133	18.5	193	48.8	253	11.5
1s	8	14	0.0	74	1.7	134	16.6	194	48.1	254	7.2
1s	8	15	0.0	75	5.8	135	17.5	195	48.6	255	2.5
1s	8	16	0.0	76	11.8	136	20.9	196	48.8	256	0.0
1s	8	17	0.0	77	18.3	137	25.2	197	48.5	257	0.0
1s	8	18	0.0	78	24.5	138	29.1	198	48.9	258	0.0
1s	8	19	0.0	79	29.4	139	31.4	199	49.2	259	0.0
1s	8	20	0.0	80	32.5	140	31.9	200	49.9	260	0.0
1s	8	21	0.0	81	34.2	141	31.4	201	50.0	261	0.0
1s	8	22	1.0	82	34.4	142	30.6	202	50.0	262	0.0
1s	8	23	2.6	83	34.5	143	29.5	203	50.0	263	0.0
1s	8	24	4.8	84	34.6	144	27.9	204	49.2	264	0.0
1s	8	25	7.2	85	34.7	145	24.9	205	49.0	265	0.0
1s	8	26	9.6	86	34.8	146	20.2	206	48.6	266	0.0
1s	8	27	12.0	87	35.2	147	14.8	207	47.3	267	0.5
1s	8	28	14.3	88	36.0	148	9.5	208	44.6	268	2.9
1s	8	29	16.6	89	37.0	149	4.8	209	43.2	269	8.2
1s	8	30	18.9	90	37.9	150	1.4	210	42.5	270	13.2
1s	8	31	21.2	91	38.5	151	0.0	211	42.9	271	17.8
1s	8	32	23.5	92	38.8	152	0.0	212	43.4	272	21.4
1s	8	33	25.6	93	38.8	153	0.0	213	44.4	273	24.1
1s	8	34	27.1	94	38.7	154	0.0	214	45.5	274	26.4
1s	8	35	28.0	95	38.4	155	0.0	215	45.5	275	28.4
1s	8	36	28.7	96	38.0	156	0.0	216	43.7	276	29.9
1s	8	37	29.2	97	37.4	157	0.0	217	42.7	277	30.4
1s	8	38	29.8	98	36.9	158	0.0	218	40.9	278	30.5
1s	8	39	30.3	99	36.6	159	0.0	219	38.4	279	30.3
1s	8	40	29.6	100	36.4	160	0.0	220	34.8	280	30.2
1s	8	41	28.7	101	36.4	161	0.0	221	34.0	281	30.1
1s	8	42	27.9	102	36.5	162	0.0	222	35.8	282	30.1
1s	8	43	27.5	103	36.7	163	0.0	223	39.7	283	30.1
1s	8	44	27.3	104	36.9	164	0.0	224	45.1	284	30.1
1s	8	45	27.3	105	37.0	165	0.0	225	48.7	285	30.1
1s	8	46	27.4	106	37.2	166	0.0	226	50.0	286	30.1
1s	8	47	27.5	107	37.3	167	0.0	227	50.0	287	30.2
1s	8	48	27.6	108	37.4	168	0.0	228	49.7	288	30.4
1s	8	49	27.6	109	37.3	169	0.0	229	48.3	289	31.0
1s	8	50	27.7	110	36.8	170	0.0	230	47.2	290	31.8
1s	8	51	27.8	111	35.8	171	0.0	231	47.0	291	32.7
1s	8	52	28.1	112	34.6	172	0.0	232	47.1	292	33.6
1s	8	53	28.6	113	31.8	173	0.0	233	46.8	293	34.4
1s	8	54	28.9	114	28.9	174	0.0	234	45.8	294	35.0
1s	8	55	29.2	115	26.7	175	0.0	235	44.2	295	35.4
1s	8	56	29.4	116	24.6	176	0.0	236	42.4	296	35.5
1s	8	57	29.7	117	25.2	177	0.0	237	40.7	297	35.3
1s	8	58	30.1	118	26.2	178	0.0	238	38.9	298	34.9
1s	8	59	30.5	119	27.5	179	0.0	239	37.0	299	33.9
1s	8	60	30.7	120	29.2	180	0.0	240	35.2	300	32.4

Table 31: WMTC, part 1, reduced speed, version 8, 1 to 300 s

Worldwide Harmonised Motorcycle Emissions Certification Procedure, Draft Technical Report

Part	version	time in s	v in km/h	time in s	v in km/h	time in s	v in km/h	time in s	v in km/h	time in s	v in km/h
1s	8	301	30.6	361	27.1	421	34.0	481	0.0	541	0.0
1s	8	302	28.9	362	26.0	422	35.4	482	0.0	542	2.7
1s	8	303	27.8	363	25.4	423	36.5	483	0.0	543	8.0
1s	8	304	27.2	364	25.5	424	37.5	484	0.0	544	16.0
1s	8	305	26.9	365	26.3	425	38.6	485	0.0	545	24.0
1s	8	306	26.5	366	27.3	426	39.7	486	1.4	546	32.0
1s	8	307	26.1	367	28.4	427	40.7	487	4.5	547	37.2
1s	8	308	25.7	368	29.2	428	41.5	488	8.8	548	40.4
1s	8	309	25.5	369	29.5	429	41.7	489	13.4	549	43.0
1s	8	310	25.7	370	29.4	430	41.5	490	17.3	550	44.6
1s	8	311	26.4	371	28.9	431	41.0	491	19.2	551	45.2
1s	8	312	27.3	372	28.1	432	40.6	492	19.7	552	45.3
1s	8	313	28.1	373	27.2	433	40.3	493	19.8	553	45.4
1s	8	314	27.9	374	26.3	434	40.1	494	20.7	554	45.5
1s	8	315	26.0	375	25.7	435	40.1	495	23.6	555	45.6
1s	8	316	22.7	376	25.5	436	39.8	496	28.1	556	45.7
1s	8	317	19.0	377	25.6	437	38.9	497	32.8	557	45.8
1s	8	318	16.0	378	26.0	438	37.5	498	36.3	558	45.9
1s	8	319	14.6	379	26.4	439	35.8	499	37.1	559	46.0
1s	8	320	15.2	380	27.0	440	34.2	500	35.1	560	46.1
1s	8	321	16.9	381	27.7	441	32.5	501	31.1	561	46.2
1s	8	322	19.3	382	28.5	442	30.9	502	28.0	562	46.3
1s	8	323	22.0	383	29.4	443	29.4	503	27.5	563	46.4
1s	8	324	24.6	384	30.2	444	28.0	504	29.5	564	46.7
1s	8	325	26.8	385	30.5	445	26.5	505	34.0	565	47.2
1s	8	326	27.9	386	30.3	446	25.0	506	37.0	566	48.0
1s	8	327	28.1	387	29.5	447	23.4	507	38.0	567	48.9
1s	8	328	27.7	388	28.7	448	21.9	508	36.1	568	49.8
1s	8	329	27.2	389	27.9	449	20.4	509	31.5	569	50.0
1s	8	330	26.7	390	27.5	450	19.4	510	24.5	570	50.0
1s	8	331	26.6	391	27.3	451	18.8	511	17.5	571	50.0
1s	8	332	26.8	392	27.0	452	18.4	512	10.5	572	50.0
1s	8	333	27.0	393	26.5	453	18.0	513	4.5	573	50.0
1s	8	334	27.2	394	25.8	454	17.5	514	1.0	574	49.0
1s	8	335	27.4	395	25.0	455	16.9	515	0.0	575	46.7
1s	8	336	27.5	396	21.5	456	16.4	516	0.0	576	44.0
1s	8	337	27.7	397	16.0	457	16.6	517	0.0	577	41.1
1s	8	338	27.9	398	10.0	458	17.7	518	0.0	578	38.3
1s	8	339	28.1	399	5.0	459	19.3	519	2.9	579	35.4
1s	8	340	28.3	400	2.2	460	20.9	520	8.0	580	31.8
1s	8	341	28.6	401	1.0	461	22.3	521	16.0	581	27.3
1s	8	342	29.0	402	0.0	462	23.2	522	24.0	582	22.4
1s	8	343	29.5	403	0.0	463	23.2	523	32.0	583	17.7
1s	8	344	30.1	404	0.0	464	22.2	524	38.8	584	13.4
1s	8	345	30.5	405	0.0	465	20.3	525	43.1	585	9.3
1s	8	346	30.7	406	0.0	466	17.9	526	46.0	586	5.5
1s	8	347	30.8	407	0.0	467	15.2	527	47.5	587	2.0
1s	8	348	30.8	408	1.2	468	12.3	528	47.5	588	0.0
1s	8	349	30.8	409	3.2	469	9.3	529	44.8	589	0.0
1s	8	350	30.8	410	5.9	470	6.4	530	40.1	590	0.0
1s	8	351	30.8	411	8.8	471	3.8	531	33.8	591	0.0
1s	8	352	30.8	412	12.0	472	1.9	532	27.2	592	0.0
1s	8	353	30.8	413	15.4	473	0.9	533	20.0	593	0.0
1s	8	354	30.9	414	18.9	474	0.0	534	12.8	594	0.0
1s	8	355	30.9	415	22.1	475	0.0	535	7.0	595	0.0
1s	8	356	30.9	416	24.7	476	0.0	536	2.2	596	0.0
1s	8	357	30.8	417	26.8	477	0.0	537	0.0	597	0.0
1s	8	358	30.4	418	28.7	478	0.0	538	0.0	598	0.0
1s	8	359	29.6	419	30.6	479	0.0	539	0.0	599	0.0
1s	8	360	28.4	420	32.4	480	0.0	540	0.0	600	0.0

Table 32: WMTC, part 1, reduced speed, version 8, 301 to 600 s

Annex C – Test Protocol

With Appendix A – US-FTP Subpart F, Emission Regulations for 1978 and Later New Motorcycles; Test Procedures

Test Bench Measurement Specifications

The test bench measurement specifications are based on the US FTP procedure as specified in subpart F. Subpart F is attached to this protocol. The following chapters contain modifications or updates, mainly based on the work of ISO/TC22/SC22/WG17 with respect to work on updating ISO 11486 (Motorcycles - Chassis dynamometer setting method) and ISO 6460 (concerning the gas sampling and cooling aspects).

1 Emission Components

The following emission components have to be measured:

- HC
- NO_x
- CO
- CO₂

2 Exhaust Gas Measurement System

The gas-collection device is described below (proposal of ISO/TC22/SC22/WG17 for revision of ISO 6460).

- (a) This device shall be a closed type device that can collect all exhaust gases at the motorcycle exhaust outlet(s) on condition that it satisfies the back pressure condition of ± 125 mm H₂O. An open system may be used as well if it is confirmed that all the exhaust gases are collected. The gas collection shall be such that there is no condensation which could appreciably modify that nature of exhaust gases at the test temperature.
- (b) A connecting tube between the device and the exhaust gas sampling system. This tube, and the device shall be made of stainless steel, or of some other material which does not affect the composition of the gases collected and which withstands the temperature of these gases.

- (c) A heat exchanger capable of limiting the temperature variation of the diluted gases in the pump intake to $\pm 5^{\circ}\text{C}$ throughout the test. This exchanger shall be equipped with a preheating system able to bring the exchanger to its operating temperature (with the tolerance of $\pm 5^{\circ}\text{C}$) before the test begins.
- (d) A positive displacement pump to draw in the dilute exhaust mixture. This pump is equipped with a motor having several strictly controlled uniform speeds. The pump capacity shall be large enough to ensure the intake of the exhaust gases. A device using a critical flow Venturi may also be used.
- (e) A device to allow continuous recording of the diluted exhaust mixture entering the pump.
- (f) Two gauges; the first to ensure the pressure depression of the dilute exhaust mixture entering the pump, relative to atmospheric pressure, the other to measure the dynamic pressure variation of the positive displacement pump.
- (g) A probe located near to, but outside the gas collecting device, to collect, through a pump, a filter and a flowmeter, samples of the dilution air stream, at constant flow rates throughout the test.
- (h) A sample probe pointed upstream into the dilute exhaust mixture flow, upstream of the positive displacement pump to collect, through a pump, a filter and a flowmeter, samples of the dilute exhaust mixture, at constant flow rates, throughout the test.
- (i) The minimum sample flow rate in the two sampling devices described above and in (g) shall be at least 150 l/h.
- (j) Three way valves on the sampling system described in (g) and (h) to direct the samples either to their respective bags or to the outside throughout the test.
- (k) Gas-tight collection bags for dilution air and dilute exhaust mixture of sufficient capacity so as not to impede normal sample flow and which will not change the nature of the pollutants concerned.
- (l) The bags shall have an automatic self-locking device and shall be easily and tightly fastened either to the sampling system or the analyzing system at the end of the test.
- (m) A revolution counter to count the revolutions of the positive displacement pump throughout the test.

NOTE 1 Good care shall be taken on the connecting method and the material or configuration of the connecting parts because there is a possibility that each section (e.g. the adapter and the coupler) of the sampling system becomes very hot. It the measurement cannot be performed normally due to heat-damages of the sampling system, an auxiliary cooling device may be used as long as the exhaust gases are not affected.

NOTE 2 Open type devices have risks of incomplete gas collection and gas leakage into the test cell. It is necessary to make sure there is no leakage throughout the sampling period.

NOTE 3 If a constant CVS flow rate is used throughout the test cycle that includes low and high speeds all in one (i.e. Part 1, 2 and 3 cycles of WMTC validation test step 2 mode), special attention should be paid because of higher risk of water condensation in high speed range.

The exhaust gas analytical system shall comply with the requirements of the US certification procedure. (see Subpart F, Sec. 86.511-90. See also Sec. 86.514-78 for the requirements for analytical gases.)

The measurement system has to be calibrated as described in the regional certification procedures.

3 Fuel and Engine Lubricant Specifications

Each region has its own specifications for the fuel and engine lubricants. The US specifications are described in Subpart F, Sec. 86.513-94, the European specifications are described in Annex II, of 97/24 Ch. 5 EC, the Japanese specifications in TRIAS 23-6-1999

Each region should use its own specifications. For the European part of the validation program, it is quite clear that advanced fuel specs are the most appropriate. Therefore the 2000 reference fuel of directive 98/69/EC should be used, but with a reduced aromatics content (max 35%v/v) and a reduced Sulphur content of max 50 ppm.

It should be clarified by an additional step to what extend differences in the fuel specification influences the emissions results.

4 Dynamometer

4.1 General

The following requirements are copied from the US certification procedure (Subpart F, Sec. 86.508-78).

- (a) The dynamometer shall have a single roll with a diameter of at least 0.400 meter.
 - (b) The dynamometer shall be equipped with a roll revolution counter for measuring actual distance travelled.
- (b) Flywheels or other means shall be used to stimulate the inertia specified in Chapter 5.
- (c) Cooling fan specifications as proposed by ISO/TC22/SC22/WG17 for revision of ISO 6460:

Throughout the test, a variable speed cooling blower shall be positioned in front of the motorcycle, so as to direct the cooling air to the motorcycle in a manner which simulates actual operating conditions. The blower speed shall be such that, within the op-

erating range of 10 to 50 km/h, the linear velocity of the air at the blower outlet is within ± 5 km/h of the corresponding roller speed. And at the range of over 50 km/h, the linear velocity of the air shall be within $\pm 10\%$. At roller speeds of less than 10 km/h, air velocity may be zero.

The above mentioned air velocity shall be determined as an averaged value of 9 measuring points which are located at the centre of each rectangle dividing whole of the blower outlet into 9 areas (dividing both of horizontal and vertical sides of the blower outlet into 3 equal parts). Each value at those 9 points shall be within 10% of the averaged value of themselves.

The blower outlet shall have a cross section area of at least 0,4 m² and the bottom of the blower outlet shall be between 5 and 20 cm above floor level. The blower outlet shall be perpendicular to the longitudinal axis of the motorcycle between 30 and 45 cm in front of its front wheel. The device used to measure the linear velocity of the air shall be located at between 0 and 20 cm from the air outlet.

- (d) The dynamometer shall comply with the tolerances in Subpart F, Sec 86.529.

4.2 Dynamometer calibration (see Subpart F, Sec. 86.518-78)

- (a) The dynamometer shall be calibrated at least once each month or performance verified at least once each week and then calibrated as required. The dynamometer is driven above the test speed range. The device used to drive the dynamometer is then disengaged from the dynamometer and the roll is allowed to coast down. The kinetic energy of the system is dissipated by the dynamometer. This method neglects the variations in roll bearing friction due to the drive axle weight of the vehicle.
- (b) Calibration shall consist of coasting down the dynamometer for each inertia load combination used. Coast down times for the interval from 70 to 60 km/h shall be within the tolerances specified in Sec. 86.529. The dynamometer adjustments necessary to produce these results shall be noted for future reference.
- (c) The performance check consists of conducting a dynamometer coast down at one or more inertia-horsepower settings and comparing the coast down time to the table in Figure F98-9 of chapter 5. If the coast down time is outside the tolerance, a new calibration is required.

The max. speed of the FTP75 cycle is 91 km/h. The max. speed of part 3 of the WMTC is significantly higher (125 km/h). Therefore shall be examined in step 1 whether the speed range for the coast down has to be extended to higher speeds.

It is recommended to perform on road coast down measurements for validation reasons.

5 Road Load Force and Inertia Weight Determination

5.1 Actual Vehicle Road load Measurements

See chapters 7 to 9 of ISO/WD 11486, ISO/TC22/SC22/WG17 REPORT TO WMTC FE

5.2 Chassis dynamometer setting using the running resistance table

See chapter 10 of ISO/WD 11486, ISO/TC22/SC22/WG17 REPORT TO WMTC FE

If the max. speed of a vehicle as declared by the manufacturer is below 130 km/h and this speed cannot be reached on the roller bench with the test bench settings defined by table 4 of ISO/WD 11486, the coefficient b has to be adjusted so that the max. speed will be reached.

6 Test Procedures, Overview (See Subpart F, Sec. 86.527-90)

- (a) The overall test consists of prescribed sequences of fuelling, parking, and operating conditions.
- (b) The exhaust emission test is designed to determine hydrocarbon (gasoline-fuelled, natural gas-fuelled and liquefied petroleum gas-fuelled motorcycles), carbon monoxide and oxides of nitrogen mass emissions while simulating real world operation. The test consists of engine start ups and motorcycle operation on a chassis dynamometer, through a specified driving schedule. A proportional part of the diluted exhaust emissions is collected continuously for subsequent analysis, using a constant volume (variable dilution) sampler.
- (c) Except in cases of component malfunction or failure, all emission control systems installed on or incorporated in a new motorcycle shall be functioning during all procedures.
- (d) Background concentrations are measured for all species for which emissions measurements are made. For exhaust testing, this requires sampling and analysis of the dilution air.

7 Drive Instructions

7.1 General

- (a) The motorcycle must be presented in good mechanical condition. It must have been run in and driven at least 1 000 km before the test.

- (b) The vehicle shall be driven with minimum throttle movement to maintain the desired speed. No simultaneous use of brake and throttle shall be permitted.
- (c) If the vehicle cannot accelerate at the specified rate, the vehicle shall be operated with the throttle fully opened until the vehicle speed reaches the value prescribed for that time in the driving schedule.

7.2 Vehicles with Automatic Transmission (see Subpart F, Sec. 86.528-78)

- (a) Vehicles equipped with transfer cases, multiple sprockets, etc., shall be tested in the manufacturer's recommended configuration for street or highway use.
- (b) All tests shall be conducted with automatic transmissions in "Drive" (highest gear). Automatic clutch-torque converter transmissions may be shifted as manual transmissions at the option of the manufacturer.
- (c) Idle modes shall be run with automatic transmissions in "Drive" and the wheels braked.
- (d) Automatic transmissions shall shift automatically through the normal sequence of gears;
- (e) The deceleration modes shall be run in gear using brakes or throttle as necessary to maintain the desired speed.

7.3 Vehicles with Manual Transmission

- (a) Idle modes shall be run with manual transmissions in 1. gear with the clutch disengaged.
- (b) For acceleration phases manual transmissions shall be shifted from 1. to 2. gear when the engine speed reaches a value according to the following formula:

$$n_{\text{max-acc}(1)} = (0,5753 \cdot \exp(-1,9 \cdot (P_n / (m_0 + 75 \text{ kg})) - 0,10) \cdot (s - n_{\text{idle}}) + n_{\text{idle}}$$

P_n - rated power in kW

m_0 – kerb mass in kg

n – engine speed in min^{-1}

n_{idle} – idling speed in min^{-1}

s - rated engine speed in min^{-1}

- (c) Upshifts for higher gears have to be carried out during acceleration phases when the engine speed reaches a value according to the following formula:

$$n_{\text{max_acc}(i)} = (0, 5753 \cdot \exp(-1,9 \cdot (P_n / (m_0 + 75 \text{ kg}))) \cdot (s - n_{\text{idle}}) + n_{\text{idle}}$$

- Pn - rated power in kW
- m0 – kerb mass in kg
- n – engine speed in min⁻¹
- n_idle – idling speed in min⁻¹
- s - rated engine speed in min⁻¹ at max. power
- i – gear number (>= 2)

(d) The minimum engine speeds for acceleration phases in gear 2 or higher gears are accordingly defined by the following formula:

$$n_{\min_acc}(i) = n_{\max_acc}(i-1) * r(i) / r(i-1)$$

r(i) – ratio of gear i

(e) The minimum engine speeds for deceleration phases or cruising phases in gear 2 or higher gears are defined by the following formula:

$$n_{\min_dec}(i) = n_{\min_acc}(i-1) * r(i) / r(i-1)$$

r(i) – ratio of gear i

When reaching these values during deceleration phases the manual transmission has to be shifted to the next lower gear (see Figure 28).

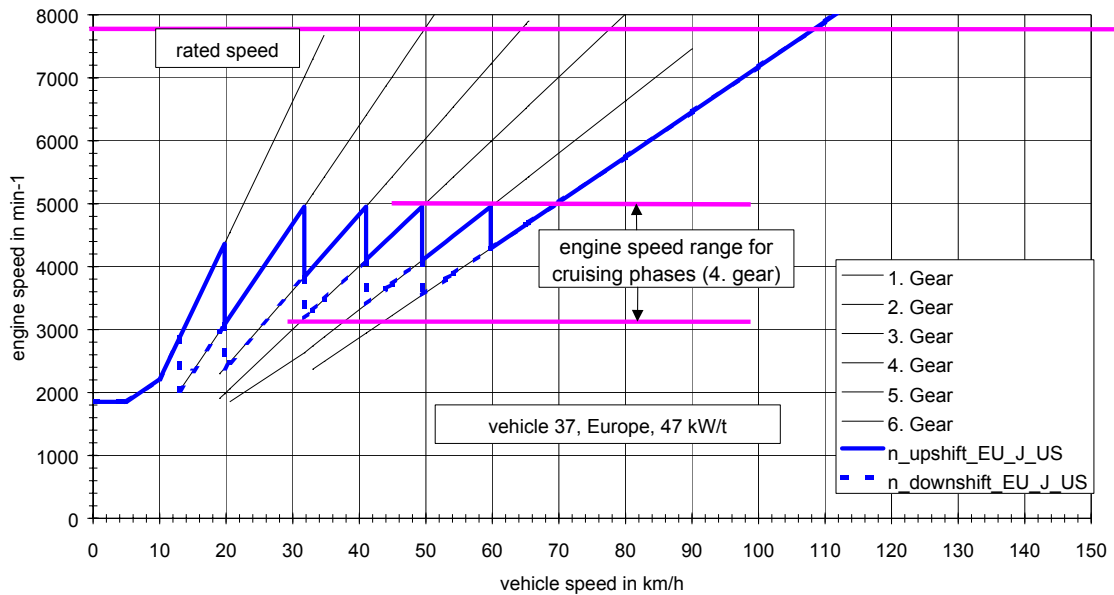

Figure 28: Example for gearshift points

- (f) There are fixed allocations for acceleration, cruising and deceleration phases (see excel spreadsheet “gearselection_0_v8_EU_J_USA”)
- (g) Gearshifts are prohibited for indicated cycle sections (see excel spreadsheet “gearselection_0_v8_EU_J_USA”)
- (h) Downshifts to the 1. gear are prohibited for those modes which require the vehicle to decelerate to zero.
- (i) Manual transmissions gear shifts shall be accomplished with minimum time with the operator closing the throttle during each shift.
- (j) For those modes that require the vehicle to decelerate to zero, manual transmission clutches shall be disengaged when the speed drops below 10 km/h, when engine roughness is evident, or when engine stalling is imminent.
- (k) While the clutch is disengaged the vehicle shall be shifted to the appropriate gear for starting the next mode.

In general it is allowed to use higher shift speeds than indicated in the calculation sheet.

For vehicles with a very low max. speed and low power to mass ratio it may happen, that the calculation sheet skips gears during acceleration and deceleration phases. The phases where this may occur are indicated in the figures of the spreadsheet. In case of gear skipping appropriate corrections have to be made by the user either by decreasing the minimum time span for a gear from 3 s to 2 s or by using higher engine speeds.

All deviations from the shift points of the calculation sheet have to be indicated in the results form.

For other cycles please refer to the gearshift prescriptions of the corresponding measurement procedure. If this procedure allows alternatives that one chosen for the test has to be reported.

8 Test Sequence

8.1 General Requirements (see Subpart F, Sec. 86.530-78)

- (a) Ambient temperature levels encountered by the test vehicle throughout the test sequence shall not be less than 20 °C (68 °F) nor more than 30 °C (86 °F). The vehicle shall be approximately level during the emission test to prevent abnormal fuel distribution.

8.2 Vehicle Preparation (see Subpart F, Sec. 86.531-78)

- (a) The manufacturer shall provide additional fittings and adapters, as required to accommodate a fuel drain at the lowest point possible in the tank(s) as installed on the vehicle and to provide for exhaust sample collection.

8.3 Vehicle preconditioning (see Subpart F, Sec. 86.532-78)

- (a) The vehicle shall be moved to the test area and the following operations performed:
 - (1) The fuel tank(s) shall be drained through the provided fuel tank(s) drain(s) and charged with the specified test fuel to half the tank(s) capacity.
 - (2) The vehicle shall be placed, either by being driven or pushed, on a dynamometer and operated through the WMTC cycle part 1. The vehicle need not be cold, and may be used to set dynamometer horsepower.
- (a) Practice runs over the prescribed driving schedule may be performed at test points, provided an emission sample is not taken, for the purpose of finding the minimum throttle action to maintain the proper speed-time relationship, or to permit sampling system adjustments.
- (b) Within five (5) minutes of completion of preconditioning, the vehicle shall be removed from the dynamometer and may be driven or pushed to the soak area to be parked. The vehicle shall be stored for not less than 12 hours prior to the cold start exhaust test or until oil T^a, cooling T^a or spark plug T^a equals the air temperature of the soak area.
- (c) In no case shall the vehicle be stored for more than 36 hours prior to the cold start exhaust test.

9 Dynamometer Procedure

9.1 General (see Subpart F, Sec. 86.535-90)

- (a) **The following vehicle classification reflects the WMTC Chairman's proposal and should be used as long as the vehicle classification is still under discussion.**

Depending on the engine capacity and the max. speed of the vehicle as declared by the manufacturer the following parts of the WMTC have to be run:

WMTC part 1, special	engine capacity up to 50 cm³, v_{max} higher than 50 km/h, but not higher than 60 km/h
WMTC part 1:	engine capacity higher than 50 cm³,
WMTC part 2:	engine capacity higher than 50 cm³, but lower than 150 cm³:
	v_{max} 80 km/h or higher,

engine capacity equal to or higher than 150 cm³:

v_max below 120 km/h

WMTC part 3:

engine capacity equal to or higher than 150 cm³,

v_max 120 km/h or higher

v_max is the maximum vehicle speed as declared by the manufacturer.

- (b) The dynamometer test consists of consecutive parts, a "cold" start part using the WMTC part 1 followed by WMTC part 2 (if requested in (a)), WMTC part 3 (if requested in (a)) and part 1 in "hot" condition. The emissions of each part have to be sampled in a separate bag.

If a motorcycle has to be tested in all 3 parts of the WMTC and the measurement device is equipped with no more than 3 bags, use the 3 bags for part 1 (cold start), part 2 and part 3. Then establish a hot soak period of 10 min to reset one bag and start part 1 in hot condition. The same procedure is used in the US-FTP (see 3.8.3 and Subpart F, Sec. 86.537-90 (b))

- (c) Engine startup (with all accessories turned off), operation over the driving schedule, and engine shutdown make a complete cold start test. Engine startup and operation over the WMTC part 1 complete the hot start test. The exhaust emissions are diluted with ambient air and a continuously proportional sample is collected for analysis during each phase. The composite samples collected in bags are analysed for hydrocarbons, carbon monoxide, carbon dioxide, and for oxides of nitrogen. A parallel sample of the dilution air is similarly analysed for hydrocarbon, carbon monoxide, carbon dioxide, and for oxides of nitrogen.
- (d) The vehicle speed, as measured from the dynamometer roll, shall be used. A speed vs. time recording, as evidence of dynamometer test validity, shall be supplied.
- (e) The drive wheel tires must be inflated to the manufacturer's recommended pressure, ± 15 kPa (± 2.2 psi). The drive wheel tire pressure shall be reported with the test results.
- (f) If the dynamometer has not been operated during the two-hour period immediately preceding the test, it shall be warmed up for 15 minutes by operating at 50 km/h (31 mph) using a nontest vehicle, or as recommended by the dynamometer manufacturer.
- (g) If the dynamometer horsepower must be adjusted manually, it shall be set within one hour prior to the exhaust emissions test phase. The test vehicle shall not be used to make this adjustment. Dynamometers using automatic control of preselectable power settings may be set anytime prior to the beginning of the emissions test.
- (h) The driving distance, as measured by counting the number of dynamometer roll revolutions, shall be determined for all parts of the test.

9.2 Engine Starting and Restarting (see Subpart F, Sec. 86.536-78)

- (a) The engine shall be started according to the manufacturer's recommended starting procedures. The initial 20 second idle period shall begin when the engine starts.
- (1) *Choke operation.*
- I. Vehicles equipped with automatic chokes shall be operated according to the instructions in the manufacturer's operating instructions or owner's manual including choke setting and "kick-down" from cold fast idle. The transmission shall be placed in gear 15 seconds after the engine is started. If necessary, braking may be employed to keep the drive wheels from turning.
 - II. Vehicles equipped with manual chokes shall be operated according to the manufacturer's operating instructions or owner's manual. Where times are provided in the instructions, the point for operation may be specified, within 15 seconds of the recommended time.
- (2) The operator may use the choke, throttle etc. where necessary to keep the engine running.
- (3) If the manufacturer's operating instructions or owner's manual do not specify a warm engine starting procedure, the engine (automatic and manual choke engines) shall be started by opening the throttle about half way and cranking the engine until it starts.
- (b) If, during the cold start, the vehicle does not start after 10 seconds of cranking, or ten cycles of the manual starting mechanism, cranking shall cease and the reason for failure to start determined. The revolution counter on the constant volume sampler shall be turned off and the sample solenoid valves placed in the "standby" position during this diagnostic period. In addition, either the CVS blower shall be turned off or the exhaust tube disconnected from the tailpipe during the diagnostic period.
- (1) If failure to start is an operational error, the vehicle shall be rescheduled for testing from a cold start. If failure to start is caused by vehicle malfunction, corrective action (following the unscheduled maintenance provisions) of less than 30 minutes duration may be taken and the test continued. The sampling system shall be reactivated at the same time cranking is started. When the engine starts, the driving schedule timing sequence shall begin. If failure to start is caused by vehicle malfunction and the vehicle cannot be started, the test shall be voided, the vehicle removed from the dynamometer, corrective action taken (following the unscheduled maintenance provisions), and the vehicle rescheduled for test. The reason for the malfunction (if determined) and the corrective action taken shall be reported.
- (2) If the vehicle does not start during the hot start after ten seconds of cranking, or ten cycles of the manual starting mechanism, cranking shall cease, the test shall be voided, the vehicle removed from the dynamometer, corrective action taken in accordance with Subpart E, Sec. 86.428 or 86.429, and the vehicle re-scheduled for test. The reason for the malfunction (if determined) and the corrective action taken shall be reported.

(c) If the engine "false starts", the operator shall repeat the recommended starting procedure (such as resetting the choke, etc.)

(d) *Stalling*

(1) If the engine stalls during an idle period, the engine shall be restarted immediately and the test continued. If the engine cannot be started soon enough to allow the vehicle to follow the next acceleration as prescribed, the driving schedule indicator shall be stopped. When the vehicle restarts, the driving schedule indicator shall be reactivated.

(2) If the engine stalls during some operating mode other than idle, the driving schedule indicator shall be stopped, the vehicle shall then be restarted and accelerated to the speed required at that point in the driving schedule and the test continued. During acceleration to this point, shifting shall be performed in accordance with chapter 7.3.

(3) If the vehicle will not restart within one minute, the test shall be voided, the vehicle removed from the dynamometer, corrective action taken, and the vehicle rescheduled for test. The reason for the malfunction (if determined) and the corrective action taken shall be reported.

9.3 Dynamometer test runs (see Subpart F, Sec. 86.537-90)

(a) The vehicle shall be allowed to stand with the engine turned off (see chapter 8.3) for required time). The vehicle shall be stored prior to the emission test in such a manner that precipitation (*e.g.*, rain or dew) does not occur on the vehicle. The dynamometer test consists of consecutive parts. The complete dynamometer test consists of consecutive parts as described in 9 (a) and (b).

(b) The following steps shall be taken for each test:

(1) Place drive wheel of vehicle on dynamometer without starting engine.

(2) Activate vehicle cooling fan.

(3) For all vehicles, with the sample selector valves in the "standby" position connect evacuated sample collection bags to the dilute exhaust and dilution air sample collection systems.

(4) Start the CVS (if not already on), the sample pumps and the temperature recorder. (The heat exchanger of the constant volume sampler, if used, and sample lines should be preheated to their respective operating temperatures before the test begins.)

(5) Adjust the sample flow rates to the desired flow rate and set the gas flow measuring devices to zero.

i. For gaseous bag samples (except hydrocarbon samples), the minimum flow rate is 0.17 cfm (0.08 l/s).

- ii. (ii) For hydrocarbon samples, the minimum FID (or HFID in the case of methanol-fuelled vehicles) flow rate is 0.066 cfm (0.031 l/s).
- (6) Attach the flexible exhaust tube to the vehicle tailpipe(s).
- (7) Start the gas flow measuring device, position the sample selector valves to direct the sample flow into the "transient" exhaust sample bag, the "transient" dilution air sample bag, turn the key on, and start cranking the engine.
- (8) Fifteen seconds after the engine starts, place the transmission in gear.
- (9) Twenty seconds after the engine starts, begin the initial vehicle acceleration of the driving schedule.
- (10) Operate the vehicle according to the WMTC driving cycles.
- (11) At the end of the part 1 in "cold" condition, simultaneously switch the sample flows from the 1. bags and samples to the 2. bags and samples, switch off gas flow measuring device No. 1 and, start gas flow measuring device No. 2. At the end of part 2, simultaneously switch the sample flows from the 2. bags and samples to the 3. bags and samples, switch off gas flow measuring device No. 2 and, start gas flow measuring device No. 3. Before starting a new part, record the measured roll or shaft revolutions and reset the counter or switch to a second counter. As soon as possible, transfer the exhaust and dilution air samples to the analytical system and process the samples according to Subpart F, Sec. 86.540, obtaining a stabilised reading of the exhaust bag sample on all analysers within 20 minutes of the end of the sample collection phase of the test.
- (12) All parts of the test shall be sampled in different bags.
- (13) Turn the engine off 2 seconds after the end of the last part of the test.
- (14) Immediately after the end of the sample period, turn off the cooling fan.
- (15) Turn off the CVS or disconnect the exhaust tube from the tailpipe(s) of the vehicle.
- (16) Disconnect the exhaust tube from the vehicle tailpipe(s) and remove the vehicle from dynamometer.
- (17) Repeat the steps in paragraph (b) (2) through (11) of this section for the part 1 test in hot conditions, except only 3 evacuated sample bags, 3 methanol sample impingers, and 3 formaldehyde sample impingers are required. The step in paragraph (b)(8) of this section shall begin between 9 and 11 minutes after the end of the sample period for the tests of part 1 (cold condition), part 2 and part 3.
- (18) At the end of the deceleration which is scheduled to occur at 505 seconds, simultaneously turn off gas flow measuring device No. 1 and position the sample selector valve to the "standby" position. (Engine shutdown is not part

of the hot start test sample period.) Record the measured roll or shaft revolutions.

- (19) As soon as possible, transfer the hot start "transient" exhaust and dilution air bag samples to the analytical system and process the samples according to §86.540 obtaining a stabilized reading of the bag exhaust sample on all analyzers within 20 minutes of the end of the sample collection phase of the test. Obtain methanol and formaldehyde sample analyses, if applicable, within 24 hours of the end of the sample period (if it is not possible to perform analysis on the methanol and formaldehyde samples within 24 hours, the samples should be stored in a dark, cold (~ 0 °C) environment until analysis).
- (20) Disconnect the exhaust tube from the vehicle tailpipe(s) and remove the vehicle from dynamometer.
- (21) The CVS or CFV may be turned off, if desired.
- (22) For comparison and analysis reasons besides the bag results also second by second data of the emissions (diluted gas) have to be monitored. For the same reasons also the temperatures of the cooling water and the crankcase oil as well as the catalyst temperature shall be recorded.
- (23) Each test shall be repeated at least twice

10 Exhaust Sample Analysis.

The exhaust sample analysis shall be carried out as described in Subpart F, Sec. 86.540-90.

11 Records required (see Subpart F, Sec. 86.542-90)

The following information shall be recorded with respect to each test:

- (a) Test number,
- (b) System or device tested (brief description),
- (c) Date and time of day for each part of the test schedule,
- (d) Instrument operator,
- (e) Driver or operator,
- (f) *Vehicle*: Make, Vehicle identification number, Model year, Transmission type, Odometer reading at initiation of preconditioning, Engine displacement, Engine family, Emission control system, Recommended idle RPM, Nominal fuel tank capacity,

Inertial loading, Actual curb mass recorded at 0 kilometres, and Drive wheel tire pressure.

- (g) *Dynamometer serial number*: As an alternative to recording the dynamometer serial number, a reference to a vehicle test cell number may be used, with the advance approval of the Administrator, provided the test cell records show the pertinent instrument information.
- (h) All pertinent instrument information such as tuning-gain-serial number-detector number-range. As an alternative, a reference to a vehicle test cell number may be used, with the advance approval of the Administrator, provided test cell calibration records show the pertinent instrument information.
- (i) Recorder Charts: Identify zero, span, exhaust gas, and dilution air sample traces.
- (j) Test cell barometric pressure, ambient temperature and humidity.

Note: A central laboratory barometer may be used; *Provided*, that individual test cell barometric pressures are shown to be within ± 0.1 percent of the barometric pressure at the central barometer location.

- (k) Pressure of the mixture of exhaust and dilution air entering the CVS metering device, the pressure increase across the device, and the temperature at the inlet. The temperature should be recorded continuously or digitally to determine temperature variations.
- (l) The number of revolutions of the positive displacement pump accumulated during each test phase while exhaust samples are being collected. The number of standard cubic meters metered by a critical flow venturi during each test phase would be the equivalent record for a CFV-CVS.
- (m) The humidity of the dilution air.

Note: If conditioning columns are not used (see Subpart F, Sec. 86.522 and 86.544) this measurement can be deleted. If the conditioning columns are used and the dilution air is taken from the test cell, the ambient humidity can be used for this measurement.

- (n) The emissions results for each part of the test.
- (o) The driving distance for each of the four parts of test, calculated from the measured roll or shaft revolutions.
- (p) The actual vehicle speed pattern of the test.
- (q) The second by second emission values.

12 Calculations; Exhaust Emissions

The final reported test results shall be computed as described in Subpart F, Sec. 86.544-90 but for each part of the test separately (no weighted overall result).

Appendix A

US FTP, Subpart F

Emission Regulations for 1978 and Later New Motorcycles; Test Procedures

Subpart F — Emission Regulations for 1978 and Later New Motorcycles; Test Procedures

SOURCE: 42 FR 1137, Jan. 5, 1977, unless otherwise noted.

§ 86.501-78 Applicability.

(a) This subpart contains the motorcycle test procedures specified in subpart E.

(b) Provisions of this subpart apply to tests performed by both the Administrator and motor vehicle manufacturers.

§ 86.502-78 Definitions.

(a) The definitions in § 86.402-78 apply to this subpart.

(b) [Reserved]

§ 86.503-78 Abbreviations.

(a) The abbreviations in § 86.403-78 apply to this subpart.

(b) [Reserved]

§ 86.504-78 Section numbering.

(a) The section numbering system described in § 86.404-78 is used in this subpart.

(b) [Reserved]

§ 86.505-78 Introduction; structure of subpart.

(a) This subpart describes the equipment required and the procedures to follow in order to perform exhaust emission tests on motorcycles. Subpart E sets forth the testing requirements and test intervals necessary to comply with EPA certification procedures.

(b) Three topics are addressed in this subpart. Sections 86.508 through 86.515 set forth specifications and equipment requirements; §§ 86.516 through 86.526 discuss calibration methods and frequency; test procedures and data requirements are listed (in approximate order of performance) in § 86.527 through 86.544.

§ 86.508-78 Dynamometer.

(a) The dynamometer shall have a single roll with a diameter of at least 0.400 metre.

(b) The dynamometer shall be equipped with a roll revolution counter for measuring actual distance traveled.

(c) Flywheels or other means shall be used to stimulate the inertia specified in § 86.529.

(d) A variable speed cooling blower shall direct air to the vehicle. The blower outlet shall be at least 0.40 m² (4.31 ft²) and shall be squarely positioned between 0.3 m (0.98 ft) and 0.45 m (1.48 ft) in front of the vehicle's front wheel. The velocity of the air at the blower outlet shall be within the following limits (as a function of roll speed):

Actual roll speed	Allowable cooling air speed
0 km/h to 5 km/h	0 km/h to 10 km/h.
5 km/h to 10 km/h	0 km/h to roll speed + 5 km/h.
10 km/h to 50 km/h ..	Roll speed \pm 5 km/h.
50 km/h to 70 km/h ..	Roll speed \pm 10 pct.
Above 70 km/h	At least 63 km/h.

(e) The dynamometer shall comply with the tolerances in § 86.529.

[42 FR 1137, Jan. 5, 1977, as amended at 42 FR 56738, Oct. 28, 1977]

§ 86.509-90 Exhaust gas sampling system.

(a)(1) *General.* The exhaust gas sampling system is designed to measure the true mass emissions of vehicle exhaust. In the CVS concept of measuring mass emissions, two conditions must be satisfied: the total volume of the mixture of exhaust and dilution air must be measured and a continuously proportioned volume of sample must be collected for analysis. Mass emissions are determined from the sample concentration and totalized flow over the test period.

(2) *Vehicle tailpipe to CVS duct.* For methanol fueled vehicles, cooling of the exhaust gases in the duct connecting the vehicle tailpipe to the CVS shall be minimized. This may be accomplished by:

(i) Using a duct of unrestricted length maintained at a temperature above the maximum dew point of the exhaust, but below 121 °C (250 °F); heating and possibly cooling capabilities are required; or

(ii) Using a short duct (up to 12 feet

long) constructed of smooth wall pipe with a minimum of flexible sections, maintained at a temperature above the maximum dew point of the exhaust, but below 121 °C (250 °F), prior to the test and during any breaks in the test and uninsulated during the test (insulation may remain in place and/or heating may occur during testing provided maximum temperature is not exceeded); or

(iii) Using smooth wall duct less than five feet long with no required heating. A maximum of two short flexible connectors are allowed under this option; or

(iv) Omitting the duct and performing the exhaust gas dilution function at the motorcycle tailpipe exit.

(3) *Positive displacement pump.* The Positive Displacement Pump-Constant Volume Sampler (PDP-CVS), Figure F90-1 satisfies the first condition by metering at a constant temperature and pressure through the pump. The total volume is measured by counting the revolutions made by the calibrated positive displacement pump. The proportional samples are achieved by sampling at a constant flow rate. For methanol-fueled motorcycle sample lines for the methanol and formaldehyde samples are heated to prevent condensation. The temperature of the sample lines shall be more than 3 °C (5 °F) above the maximum dew point of the sample, but below 121 °C (250 °F). (Note: For 1990 through 1994 model year methanol-fueled motorcycles, methanol and formaldehyde sampling may be omitted provided the bag sample (hydrocarbons and methanol) is analyzed using a HFID calibrated with methanol.)

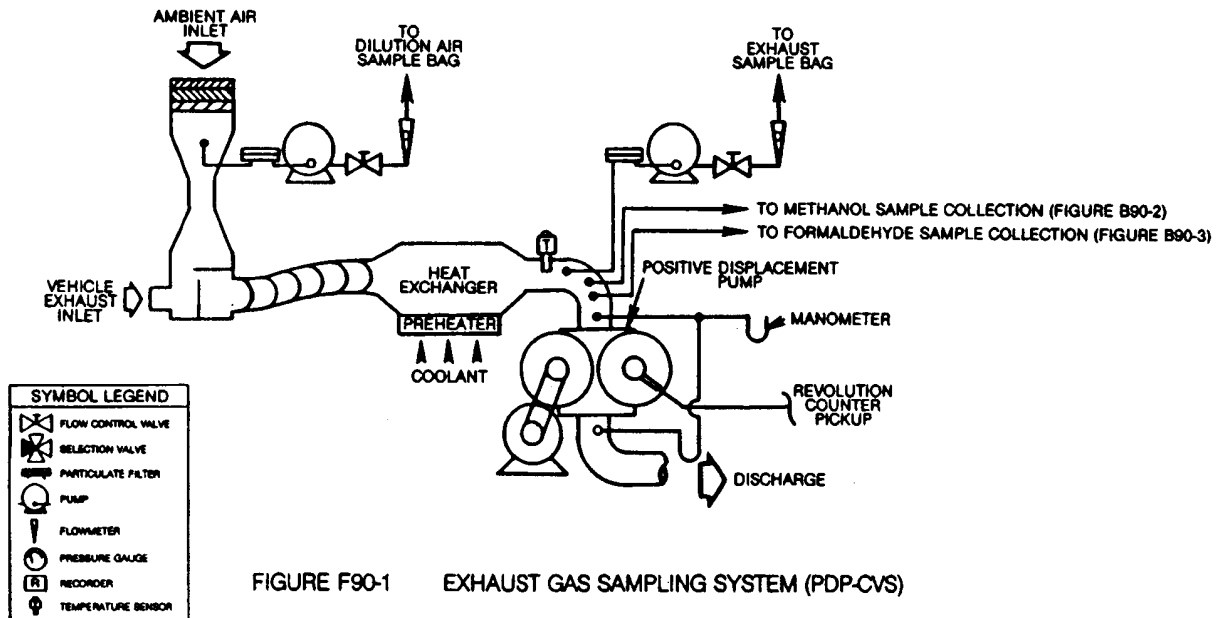

(4) *Critical flow venturi.* The operation of the Critical Flow Venturi—Constant Volume Sampler (CFV-CVS) sample system, Figure F90-2, is based upon the principles of fluid dynamics associated with critical flow. Proportional sampling throughout temperature excursions is maintained by use of small CFVs in the sample lines, which respond to the varying temperatures in the same manner as the main CFV. For methanol-fueled motorcycles, the methanol and formaldehyde sample lines are heated to prevent condensation. The temperature of the sample lines shall be more than 3 °C (5 °F) above the maximum dew point of the sample, but below

121 °C (250 °F). Care must be taken to ensure that the CFVs of the sample probes are not heated since heating of the CFVs would cause loss of proportionality. (Note: For 1990 through 1994 model year methanol-fueled motorcycles, methanol and formaldehyde sampling may be omitted provided the bag sample (hydrocarbons and methanol) is analyzed using a HFID calibrated with methanol.) Total flow per test is determined by continuously computing and integrating instantaneous flow. A low response time temperature sensor is necessary for accurate flow calculation.

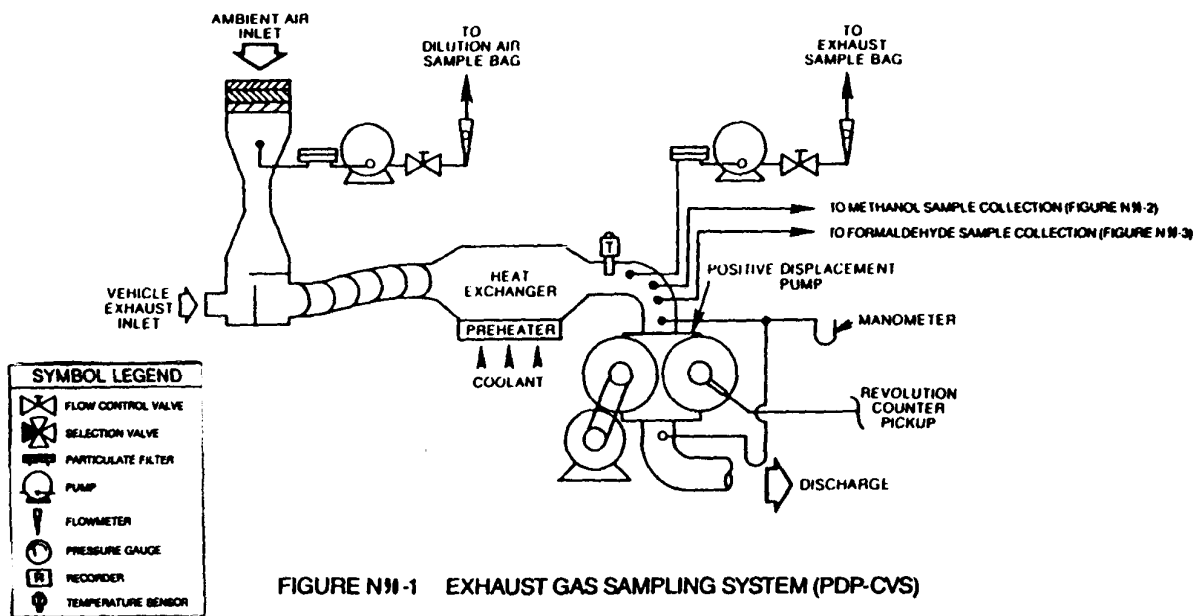

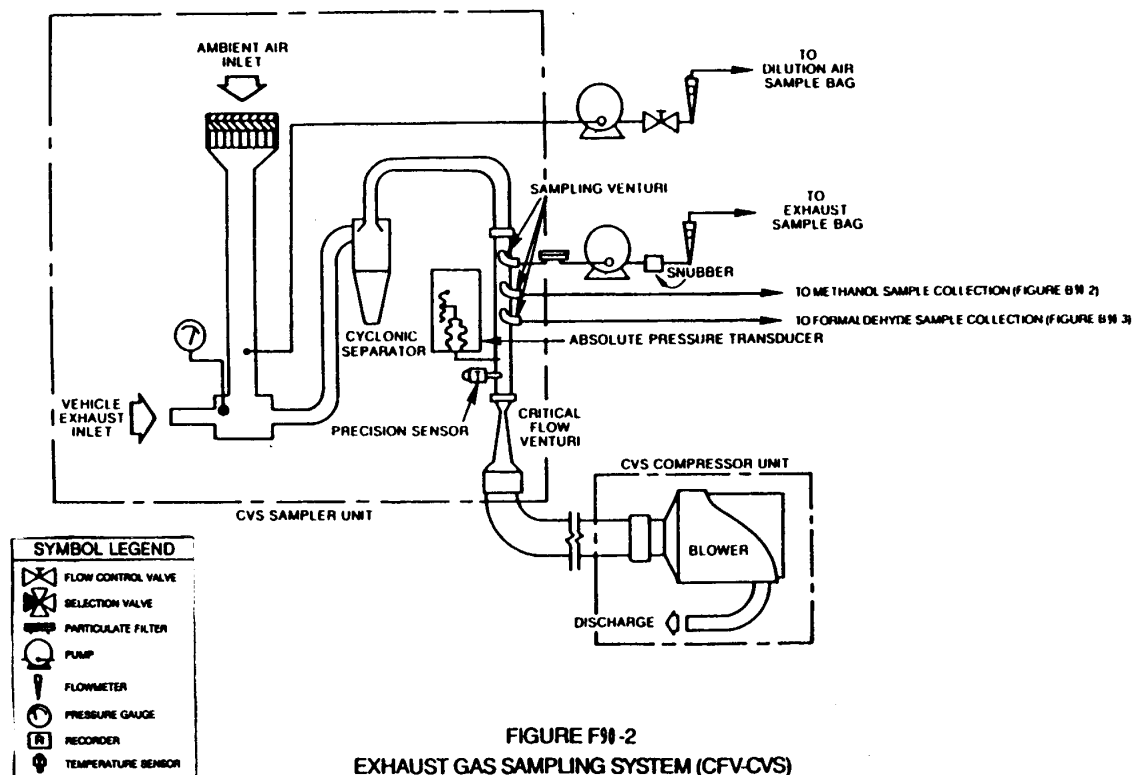

FIGURE F90-2
EXHAUST GAS SAMPLING SYSTEM (CFV-CVS)

(5) *Electronic Flow Control.* The Critical Flow Venturi—Electronic Flow Control—Constant Volume Sampler (CFV-EFC-CVS) system is identical to the CFV-CVS system described in paragraphs (a)(4) and (c) of this section, except that it maintains proportional sampling for methanol and formaldehyde by measuring the CVS flow rate, and electronically controlling sample flow rates. It is recommended that sample volumes be measured by separate flow meters. For methanol-fueled motorcycles, the samples lines for the methanol and formaldehyde samples are heated to prevent condensation. The temperature of the sample lines shall be more than 20 °F (11 °C) above the maximum dew point of the sample, but below 121 °C (250 °F).

(6) *Other systems.* Other sampling systems may be used if shown to yield equivalent results, and if approved in ad-

vance by the Administrator (e.g., a heat exchanger with the CFV-CVS or an electronic flow integrator without a heat exchanger, with the PDP-CVS).

(b) *Component description, PDP-CVS.* The PDP-CVS, Figure F90-1, consists of a dilution air filter and mixing assembly, heat exchanger, positive displacement pump, sampling systems including, probes and sampling lines which, in the case of the methanol-fueled motorcycles, are heated to prevent condensation (heating of the sample lines may be omitted, provided the methanol and formaldehyde sample collection systems are close coupled to the probes thereby preventing loss of sample due to cooling and resulting condensation in the sample lines), and associated valves, pressure and temperature sensors. The PDP-CVS shall conform to the following requirements:

(1) Static pressure variations at the

tailpipe(s) of the vehicle shall remain within ± 1.25 kPa (± 5.02 in H_2O) of the static pressure variations measured during a dynamometer driving cycle with no connection to the tailpipe(s). (Sampling systems capable of maintaining the static pressure to within ± 0.25 kPa (± 1.00 in. H_2O) will be used by the Administrator if a written request substantiates the need for this closer tolerance.)

(2) The gas mixture temperature, measured at a point immediately ahead of the positive displacement pump, shall be within ± 5 °C (9 °F) of the designed operating temperature at the start of the test. The gas mixture temperature variation from its value at the start of the test shall be limited to ± 5 °C (9 °F) during the entire test. The temperature measuring system shall have an accuracy and precision of ± 1 °C (1.8 °F).

(3) The pressure gauges shall have an accuracy and precision of ± 0.4 kPa ± 3 mm Hg).

(4) The location of the dilution air inlet shall be placed so as to use test-cell air for dilution and the flow capacity of the CVS shall be large enough to completely eliminate water condensation in the dilution and sampling systems. Control of water condensation with methanol-fueled vehicles is critical. Additional care may also be required to eliminate water condensation when testing natural gas and liquefied petroleum gas-fueled vehicles. (Procedures for determining CVS flow rates are detailed in "Calculation of Emissions and Fuel Economy When Using Alternative Fuels," EPA 460/3-83-009.) Dehumidifying the dilution air before entering the CVS is allowed. Heating the dilution air is also allowed, provided:

(i) The air (or air plus exhaust gas) temperature does not exceed 121 °C (250 °F).

(ii) Calculation of the CVS flow rate necessary to prevent water condensation is based on the lowest temperature encoun-

tered in the CVS prior to sampling. (It is recommended that the CVS system be insulated when heated dilution air is used.)

(iii) The dilution ratio is sufficiently high to prevent condensation in bag samples as they cool to room temperature.

(5) Sample collection bags for dilution air and exhaust samples (hydrocarbons and carbon monoxide) shall be of sufficient size so as not to impede sample flow. A single dilution air sample, covering the total test period, may be collected for the determination of methanol and formaldehyde background (methanol-fueled motorcycles).

(6) The methanol sample collection system and the formaldehyde sample collection system shall each be of sufficient capacity so as to collect samples of adequate size for analysis without significant impact on the volume of dilute exhaust passing through the PDP. The systems shall also comply with the following requirements that apply to the design of the systems, not to individual tests:

(i) The methanol system shall be designed such that if a test motorcycle continuously emitted the maximum allowable level of methanol (based on all applicable standards) the measured concentration in the primary impinger would exceed either 25 mg/l or a concentration equal to 25 times the limit of detection for the GC analyzer.

(ii) The formaldehyde system shall be designed such that if a test motorcycle continuously emitted formaldehyde at a rate equal to twenty percent of the maximum allowable level of THCE (i.e., 1.0 g/km for a 5.0 g/km standard), or the maximum formaldehyde level allowed by a specific formaldehyde standard, whichever is less, the concentration of formaldehyde in the DNPH solution of the primary impinger, or solution resulting from the extraction of the DNPH cartridge, shall exceed either 2.5 mg/l or a concentra-

tion equal to 25 times the limit of detection for the HPLC analyzer.

(iii) The methanol and formaldehyde systems shall be designed such that the primary impinger collects at least 90 percent of the analyte in the samples. The remaining analyte shall be collected by the secondary impinger. This requirement does not apply to dilution air samples, since they do not require secondary impingers, or to samples in which the concentrations approach the limit of detection.

(c) *Component description, CFV-CVS.* The CFV-CVS sample system, Figure F90-2, consists of a dilution air filter and mixing assembly, a cyclone particulate separator, unheated sampling venturies for the bag samples, and for the methanol and formaldehyde samples from methanol-fueled vehicles, samples lines heated to prevent condensation for the methanol and formaldehyde samples from methanol fueled vehicles (heating of the sample lines may be omitted provided, the methanol and formaldehyde sample collection systems are close coupled to the probes thereby preventing loss of sample due to cooling and resulting condensation in the sample lines), a critical flow venturi, and assorted valves, and pressure and temperature sensors. The CFV sample system shall conform to the following requirements:

(1) Static pressure variations at the tailpipe(s) of the vehicle shall remain within ± 1.25 kPa (5.02 in H₂O) of the static pressure variations measured during a dynamometer driving cycle with no connection to the tailpipe(s). (Sampling systems capable of maintaining the static pressure to within ± 0.25 kPa (1.00 in H₂O) will be used by the Administrator if a written request substantiates the need for this closer tolerance.)

(2) The temperature measuring system shall have an accuracy and precision of ± 1 °C (1.8 °F.) and a response time of 0.100 second to 62.5 percent of a temperature

change (as measured in hot silicone oil).

(3) The pressure measuring system shall have an accuracy and precision of ± 0.4 kPa (± 3 mm Hg).

(4) The location of the dilution air inlet shall be placed so as to use test-cell air for dilution and the flow capacity of the CVS shall be large enough to completely eliminate water condensation in the dilution and sampling systems. Control of water condensation with methanol-fueled vehicles is critical. Additional care may also be required to eliminate water condensation when testing natural gas and liquefied petroleum gas-fueled vehicles. (Procedures for determining CVS flow rates are detailed in "Calculation of Emissions and Fuel Economy When Using Alternative Fuels," EPA 460/3-83-009.) Dehumidifying the dilution air before entering the CVS is allowed. Heating the dilution air is also allowed, provided:

(i) The air (or air plus exhaust gas) temperature does not exceed 250 °F.

(ii) Calculation of the CVS flow rate necessary to prevent water condensation is based on the lowest temperature encountered in the CVS prior to sampling. (It is recommended that the CVS system be insulated when heated dilution air is used.)

(iii) The dilution ratio is sufficiently high to prevent condensation in bag samples as they cool to room temperature.

(5) Sample collection bags for dilution air and exhaust samples (hydrocarbons and carbon monoxide) shall be of sufficient size so as not to impede sample flow. A single dilution air sample, covering the total test period, may be collected for the determination of methanol and formaldehyde background (methanol-fueled motorcycles).

(6) The methanol sample collection

system and the formaldehyde sample collection system shall each be of sufficient capacity so as to collect samples of adequate size for analysis without significant impact on the volume of dilute exhaust passing through the CVS. The systems shall also comply with the following requirements that apply to the design of the systems, not to individual tests:

(i) The methanol system shall be designed such that if a test motorcycle continuously emitted the maximum allowable level of methanol (based on all applicable standards) the measured concentration in the primary impinger would exceed either 25 mg/l or a concentration equal to 25 times the limit of detection for the GC analyzer.

(ii) The formaldehyde system shall be designed such that if a test motorcycle continuously emitted formaldehyde at a rate equal to twenty percent of the maximum allowable level of THCE (i.e., 1.0 g/km for a 5.0 g/km standard), or the maximum formaldehyde level allowed by a specific formaldehyde standard, whichever is less, the concentration of formaldehyde in the DNPH solution of the primary impinger, or solution resulting from the extraction of the DNPH cartridge, shall exceed either 2.5 mg/l or a concentration equal to 25 times the limit of detection for the HPLC analyzer.

(iii) The methanol and formaldehyde systems shall be designed such that the primary impinger collects at least 90 percent of the analyte in the samples. The remaining analyte shall be collected by the secondary impinger. This requirement does not apply to dilution air samples, since they do not require secondary impingers, or to samples in which the concentrations approach the limit of detection.

(d) *Component description, CFV-EFC- CVS.* The CVS sample system is identical to the system described in paragraph (c) of this section, plus includes a means of electronically measuring the CVS flow rate, and elec-

tronic mass flow controllers for the methanol and formaldehyde sample lines, and separate flow meters to totalize sample flow volumes (optional). The EFC sample system shall conform to all of the requirements listed in paragraph (c) of this section, except that the methanol and formaldehyde samples may both be drawn from a single static probe. It also must comply with the following additional requirements:

(1) The ratio of the CVS flow rate to the sample flow rate shall not deviate from the ratio at the start of the test by more than ± 5 percent. (The volumetric sample flow rate shall be varied inversely with the square root of the bulk stream temperature.)

(2) Flow totalizers for methanol and/or formaldehyde samples shall have an accuracy of ± 2 percent. Total sample volumes may be obtained from the flow controllers, with the advance approval of the administrator, provided that the controllers can be shown to have an accuracy of ± 2 percent.

[54 FR 14539, Apr. 11, 1989, as amended at 59 FR 48512, Sept. 21, 1994; 60 FR 34351, June 30, 1995]

§ 86.511-90 Exhaust gas analytical system.

(a) *Schematic drawings.* Figure F90-3 is a schematic drawing of the exhaust gas analytical system for analysis of hydrocarbons (HC) (hydrocarbons plus methanol in the case of methanol-fueled motorcycles), carbon monoxide (CO), carbon dioxide (CO₂), and oxides of nitrogen (NO_x). Since various configurations can produce accurate results, exact conformance with the drawing is not required. Additional components such as instruments, valves, solenoids, pumps and switches may be used to provide additional information and coordinate the functions of the component systems.

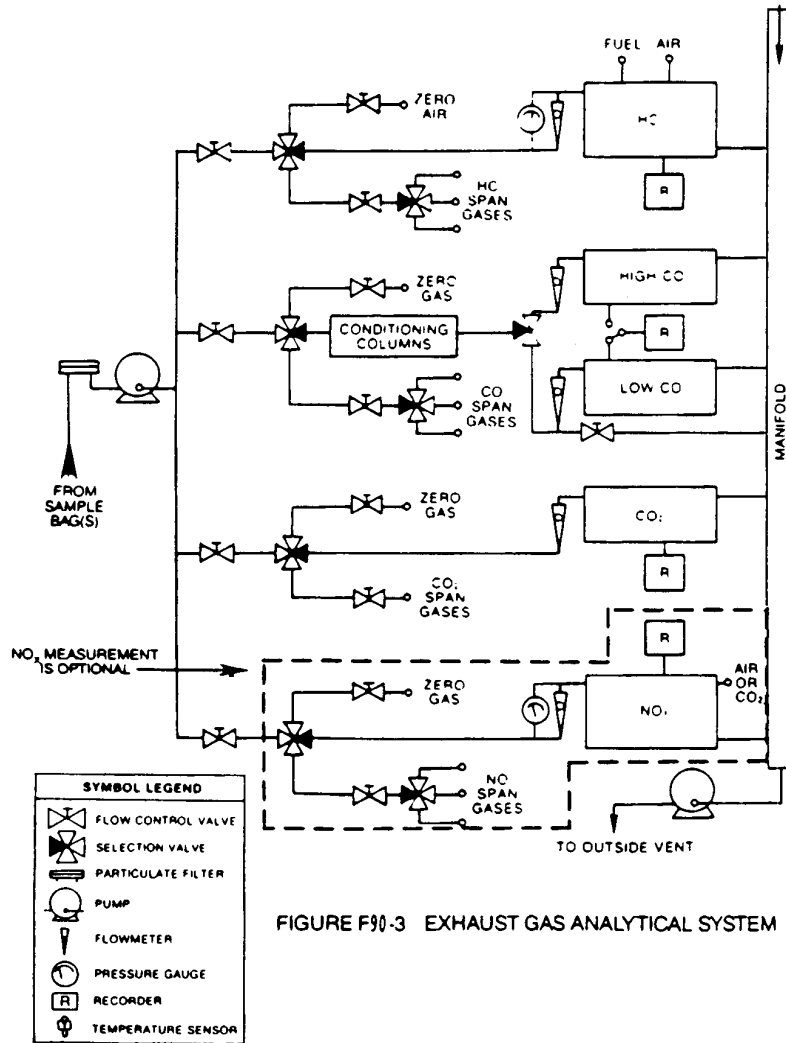

FIGURE F90-3 EXHAUST GAS ANALYTICAL SYSTEM

(b) *Major component description.* The exhaust gas analytical system for HC, CO and CO₂, Figure F90-3, consists of a flame ionization detector (FID) (heated (235 °±15 °C (113 ° ±8 °C)) for methanol-fueled vehicles) for the determination of hydrocarbons, nondispersive infrared analyzers (NDIR) for the determination of carbon monoxide and carbon dioxide and, if oxides of nitrogen are measured, a chemiluminescence analyzer (CL) for the determination of oxides of nitrogen. The analytical system for methanol consists of a gas chromatograph (GC) equipped with a flame ionization detector. The analysis for formaldehyde is performed using high pressure liquid chromatography (HPLC) of 2,4-dinitrophenylhydrazine (DNPH) derivatives using ultraviolet (UV) detection. The exhaust gas analytical system shall conform to the following requirements:

(1) The CL requires that the nitrogen dioxide present in the sample be converted to nitric oxide before analysis. Other types of analyzers may be used if shown to yield equivalent results and if approved in advance by the Administrator.

(2) The carbon monoxide (CO) NDIR analyzer may require a sample conditioning column containing CaSO₄, or indicating silica gel to remove water vapor and containing ascarite to remove carbon dioxide from the CO analysis stream.

(i) If CO instruments which are essentially free of CO₂ and water vapor interference are used, the use of the conditioning column may be deleted, see §§ 86.522 and 86.544.

(ii) A CO instrument will be considered to be essentially free of CO₂ and water vapor interference if its response to a mixture of 3 percent CO₂ in N₂ which has been bubbled through water at room temperature produces an equivalent CO response, as measured on the most sensitive CO range, which is less than 1 percent of full scale CO concentration

on ranges above 300 ppm full scale or less than 3 ppm on ranges below 300 ppm full scale; see § 86.522.

(c) *Other analyzers and equipment.* Other types of analyzers and equipment may be used if shown to yield equivalent results and if approved in advance by the Administrator.

[54 FR 14544, Apr. 11, 1989]

§ 86.513-87 Fuel and engine lubricant specifications.

(a) Gasoline having the following specifications will be used by the Administrator in exhaust emission testing. Gasoline having the following specifications or substantially equivalent specifications approved by the Administrator, shall be used by the manufacturer for emission testing except that the lead and octane specifications do not apply.

Item designation	ASTM	Leaded	Unleaded
Octane, research, min	D2699	100	93
Pb (organic), g/liter (g/U.S. gal.)	D3237	¹ 0.026 (0.100 max)	¹ 0.013 (0.050 max)
Distillation Range:	D86.		
IBP, °C (°F)	23.9-35 (75-95)	23.9-35 (75-95)
10 pct. point °C (°F)	48.9-57.2 (120-135)	48.9-57.2 (120-135)
50 pct. point °C (°F)	93.3-110 (200-230)	93.3-110 (200-230)
90 pct. point °C (°F)	148.9-162.8 (300-325)	148.9-162.8 (300-325)
EP, °C (°F)	212.8(415)	212.8(415)
Sulfur, wt. Pct., max	D1266	0.10	0.10
Phosphorus, g/liter (g/U.S. gal), mas		0.0026 (0.01)	0.0013 (0.005)
RVP, KPa (psi)	D323	55.2-63.4 (8.0-9.2)	55.2-63.4 (8.0-9.2)
Hydrocarbon composition:			
Olefins, pct., max	D1319	10	10
Aromatics, pct., max	35	35
Saturates	(²)	(²)

¹ Maximum.

² Remainder.

(b)(1) Gasoline and engine lubricants representative of commercial fuels and engine lubricants which will be generally available through retail outlets shall be used in service accumulation.

(2) For leaded fuel the lead content shall

not exceed 0.100 gram lead per gallon leaded gasoline.

(3) Where the Administrator determines that vehicles represented by a test vehicle will be operated using gasoline of different lead content than that prescribed in this paragraph, he may

consent in writing to use a gasoline with a different lead content.

(4) The octane rating of the gasoline used shall be no higher than 4.0 research octane numbers above the minimum recommended by the manufacturer.

(5) The Reid Vapor Pressure of the fuel used shall be characteristic of the motor fuel during the season in which the service accumulation takes place.

(6) If the manufacturer specifies several lubricants to be used by the ultimate purchaser, the Administrator will select one to be used during service accumulation.

(c) The specification range of the fuels and engine lubricants to be used under paragraph (b) of this section shall be reported in accordance with § 86.416.

(d) The same lubricant(s) shall be used for both service accumulation and emission testing.

(e) Fuels not meeting the specifications set forth in this section may be used only with the advance approval of the Administrator.

[51 FR 24611, July 7, 1986, as amended at 52 FR 47869, Dec. 16, 1987]

§ 86.513-90 Fuel and engine lubricant specifications.

(a) Gasoline having the following specifications will be used by the Administrator in exhaust emission testing. Gasoline having the following specifications or substantially equivalent specifications approved by the Administrator, shall be used by the manufacturer for emission testing except that the octane specifications do not apply.

Item	ASTM	Value
Octane, research, minimum	D2699	
Lead (organic):		96
g/liter	D3237	
(g/U.S. gal.)		¹ 0.013
Distillation range:		¹ (0.050)
IBP:		
°C	D86	
(°F)		23.9-35
10 pct. point:		(75-95)
°C	D86	
(°F)		48.9-57.2
50 pct. point:		(120-135)
°C	D86	
(°F)		93.3-110

90 pct. point:		(200-230)
°C	D86	
(°F)		148.9-162.8
EP:		(300-325)
°C max	D86	
(°F)		212.8
Sulfur, weight percent, maximum	D1266	(415)
Phosphorus:		0.10
g/liter, max	D3231	
(g/U.S. gal.)		0.0013
RVP, kPa (psi)	D323	(0.005)
		55.2-63.4
		(8.0-9.2)
Hydrocarbon composition:		
Olefins, percent, maximum	D1319	
Aromatics, percent, maximum	D1319	10
Saturates	D1319	35
		Remainder

¹Maximum.

(b)(1) Unleaded gasoline and engine lubricants representative of commercial fuels and engine lubricants which will be generally available through retail outlets shall be used in service accumulation.

(2) The octane rating of the gasoline used shall be no higher than 4.0 Research octane numbers above the minimum recommended by the manufacturer.

(3) The Reid Vapor Pressure of the fuel used shall be characteristic of the motor fuel during the season in which the service accumulation takes place.

(4) If the manufacturer specifies several lubricants to be used by the ultimate purchaser, the Administrator will select one to be used during service accumulation.

(c) Methanol fuel used for exhaust and evaporative emission testing and in service accumulation of methanol-fueled motorcycle vehicles shall be representative of commercially available methanol fuel and shall consist of at least 50 percent methanol by volume.

(1) Manufacturers shall recommend the methanol fuel to be used for testing and service accumulation in accordance with paragraph (c).

(2) The Administrator shall determine the methanol fuel to be used for testing and service accumulation.

(d) Other methanol fuels may be used for testing and service accumulation provided:

(1) They are commercially available, and

(2) Information, acceptable to the Administrator, is provided to show that only the designated fuel would be used in customer service, and

(3) Use of a fuel listed under paragraph (a)(3) of this section would have a detrimental effect on emissions or durability, and

(4) Written approval from the Administrator of the fuel specifications must be provided prior to the start of testing.

(e) The specification range of the fuels and engine lubricants to be used under paragraph (b) of this section shall be reported in accordance with Sec. 86.416.

(f) The same lubricant(s) shall be used for both service accumulation and emission testing.

(g) Fuels not meeting the specifications set forth in this section may be used only with the advance approval of the Administrator.

(h) *Mixtures of petroleum and methanol fuels for flexible fuel motorcycles.* (1) Mixtures of petroleum and methanol fuels used for exhaust and evaporative emission testing and service accumulation for flexible fuel motorcycles shall be within the range of fuel mixtures for which the vehicle was designed.

(2) Manufacturer testing and service accumulation may be performed using only those mixtures (mixtures may be different for exhaust testing, evaporative testing, and service accumulation) expected to result in the highest emissions, provided:

(i) The fuels which constitute the mixture will be used in customer service, and

(ii) Information, acceptable to the Administrator, is provided by the manufacturer to show that the designated fuel mixtures would result in the highest emissions, and

(iii) Written approval from the Administrator of the fuel specifications must be provided prior to the start of testing.

(3) The specification range of the fuels to be used under paragraph (h)(1) of this section shall be reported in accordance with Sec. 86.090 21(b)(3).

[53 FR 476, Jan. 7, 1988, as amended at 54 FR 14546, Apr. 11, 1989]

§ 86.513-94 Fuel and engine lubricant specifications.

(a) *Gasoline.* (1) Gasoline having the following specifications will be used by the Administrator in exhaust emission testing of gasoline-fueled motorcycles. Gasoline having the following specifications or substantially equivalent specifications approved by the Administrator, shall be used by the manufacturer for emission testing except that the octane specifications do not apply.

Item	ASTM	Value
Octane, research, minimum.....	D2699	
Lead (organic): g/liter (g/U.S. gal.)	D3237	96
Distillation range: IBP: °C (°F)	D86	¹ 0.013 ¹ (0.050) 23.9-35 (75-95)
10 pct. point: °C (°F).....	D86	48.9-57.2 (120-135)
50 pct. point: °C (°F).....	D86	93.3-110 (200-230)
90 pct. point: °C (°F).....	D86	148.9-162.8 (300-325)
EP: °C max (°F)	D86	212.8 (415)
Sulfur, max. wt. %.....	D1266	0.10
Phosphorus: max. g/liter (g/U.S. gal.).....	D3231	0.0013 (0.005)
RVP, kPa (psi).....	D323	55.2-63.4 (8.0-9.2)
Hydrocarbon composition:	D1319	
Olefins, max.,%	D1319	10
Aromatics, max.,%	D1319	35
Saturates.....		Remainder

¹Maximum.

(2) Unleaded gasoline and engine lubricants representative of commercial fuels and engine lubricants which will be generally available through retail outlets shall be used in service accumulation.

(3) The octane rating of the gasoline used shall be no higher than 4.0 Research octane numbers above the minimum recommended by the manufacturer.

(4) The Reid Vapor Pressure of the gasoline used shall be characteristic of commercial gasoline fuel during the season in which the service accumulation takes place.

(b) *Methanol fuel.* (1) Methanol fuel used for exhaust and evaporative emission test-

ing and in service accumulation of methanol-fueled motorcycles shall be representative of commercially available methanol fuel and shall consist of at least 50 percent methanol by volume.

(2) Manufacturers shall recommend the methanol fuel to be used for testing and service accumulation in accordance with paragraph (b)(1) of this section.

(3) The Administrator shall determine the methanol fuel to be used for testing and service accumulation.

(4) Other methanol fuels may be used for testing and service accumulation provided:

(i) They are commercially available; and
 (ii) Information, acceptable to the Administrator, is provided to show that only the designated fuel would be used in customer service; and

(iii) Use of a fuel listed under paragraphs (b)(1), (b)(2) or (b)(3) of this section would have a detrimental effect on emissions or durability; and

(iv) Written approval from the Administrator of the fuel specifications must be provided prior to the start of testing.

(c) *Mixtures of petroleum and methanol fuels for flexible fuel motorcycles.* (1) Mixtures of petroleum and methanol fuels used for exhaust and evaporative emission testing and service accumulation for flexible fuel motorcycles shall consist of the petroleum fuel listed in paragraph (a) of this section and the methanol fuel listed in paragraph (b), and shall be within the range of fuel mixtures for which the vehicle was designed, as reported in accordance with Sec. 86.90-21. The Administrator may use any fuel or fuel mixture within this range for testing.

(2) The fuel mixtures used by the manufacturers shall be sufficient to demonstrate compliance over the full design range, and shall include:

(i) For emission testing,
 (A) The petroleum fuel specified in paragraph (a) or (b),

(B) A methanol fuel representative of the methanol fuel expected to be found in use, as specified in paragraph (b),

(ii) For service accumulation, an alternating combination of the fuels specified in

paragraphs (a) and (b) will be used to demonstrate the durability of the emission control systems based on good engineering judgement. The combination shall be selected such that the cumulative volumes of both the methanol fuel and the petroleum fuel used shall be at least twenty-five percent of the total fuel volume. The fuels shall be alternated at mileage intervals not to exceed 1,000 kilometers.

(3) The specification range of the fuels to be used under paragraph (c) of this section shall be reported in accordance with Sec. 86.094-21.

(d) *Natural gas-fuel.* (1) Natural gas-fuel having the following specifications will be used by the Administrator for exhaust and evaporative emission testing of natural gas-fueled motorcycles. Natural gas-fuel having the following specifications or substantially similar specifications approved by the Administrator, shall be used by the manufacturer for emission testing.

NATURAL GAS CERTIFICATION FUEL SPECIFICATIONS

Item		ASTM test method No.	Value
Methane.....	min mole pct.	D1945	89.0
Ethane	max. mole pct.	D1945	4.5
C ₃ and higher	max. mole pct.	D1945	2.3
C ₆ and higher	max. mole pct.	D1945	0.2
Oxygen.....	max. mole pct.	D1945	0.6
Inert gases:			
Sum of CO ₂ and N ₂ Odorant ¹	max. mole pct.	D1945	4.0

¹The natural gas at ambient conditions must have a distinctive odor potent enough for its presence to be detected down to a concentration in air of not over 1/5 (one-fifth) of the lower limit of flammability.

(2) Natural gas-fuel and engine lubricants representative of commercial fuels and engine lubricants which will be generally available through retail outlets shall be used in service accumulation.

(3) Other natural gas-fuels may be used for testing and service accumulation provided:

(i) They are commercially available;
 (ii) Information, acceptable to the Administrator, is provided to show that only the designated fuel would be used in customer service;

(iii) Written approval from the Administrator of the fuel specifications must be provided prior to the start of testing.

(e) *Liquefied petroleum gas-fuel.* (1) Liquefied petroleum gas-fuel used for exhaust and evaporative emission testing and in service accumulation of liquefied petroleum gas-fueled motorcycles shall be commercially available liquefied petroleum gas-fuel.

(2) Manufacturers shall recommend the liquefied petroleum gas-fuel to be used for testing and service accumulation in accordance with paragraph (e)(1) of this section.

(3) The Administrator shall determine the liquefied petroleum gas-fuel to be used for testing and service accumulation.

(4) Other liquefied petroleum gas-fuels may be used for testing and service accumulation provided:

- (i) They are commercially available;
- (ii) Information, acceptable to the Administrator, is provided to show that only the designated fuel would be used in customer service; and

(iii) Written approval from the Administrator of the fuel specifications must be provided prior to the start of testing.

(f) *Lubricants.* (1) If the manufacturer specifies several lubricants to be used by the ultimate purchaser, the Administrator will select one to be used during service accumulation.

(2) The same lubricant(s) shall be used for both service accumulation and emission testing.

(g) The specification range of the fuels and of the engine lubricants to be used under paragraphs (a), (b), (c), (d) and (e) of this section shall be reported in accordance with §86.416.

(h) Written approval from the Administrator of the fuel and lubricant specifications must be provided prior to the start of testing.

[59 FR 48512, Sept. 21, 1994, as amended at 60 FR 34354, June 30, 1995]

§ 86.514-78 Analytical gases.

(a) *Analyzer gases.* (1) Gases for the CO and CO₂ analyzers shall be single blends of CO and CO₂ respectively using nitrogen as the diluent.

(2) Gases for the THC analyzer shall be:

(i) Single blends of propane using air as the diluent; and

(ii) Optionally, for response factor determination, single blends of methanol using air as the diluent.

(3) Gases for the NO_x analyzer shall be single blends of NO named as NO_x with a maximum NO₂ concentration of 5 percent of the nominal value using nitrogen as the diluent.

(4) [Reserved]

(5) The allowable zero gas (air or nitrogen) impurity concentrations shall not exceed 1 ppm equivalent carbon response, 1 ppm carbon monoxide, 0.04 percent (400 ppm) carbon dioxide, and 0.1 ppm nitric oxide.

(6) "Zero grade air" includes artificial "air" consisting of a blend of nitrogen and oxygen with oxygen concentrations between 18 and 21 mole percent.

(7) The use of proportioning and precision blending devices to obtain the required analyzer gas concentrations is allowable provided their use has been approved in advance by the Administrator.

(b) Calibration gases (not including methanol) shall be known to within 2 percent of true values.

(c) Methanol in air gases used for response factor determination shall:

(1) Be traceable to within ±2 percent of NIST (formerly NBS) gas standards, or other gas standards which have been approved by the Administrator; and

(2) Remain within ±2 percent of the labeled concentration. Demonstration of stability shall be based on a quarterly measurement procedure with a precision of ±2 percent (two standard deviations), or other method approved by the Administrator. The measurement procedure may incorporate multiple measurements. If the true concentration of the gas changes by more than two percent, but less than ten percent, the gas may be relabeled with the new concentration.

[42 FR 1137, Jan. 5, 1977, as amended at 60 FR 34354, June 30, 1995]

§ 86.515-78 EPA urban dynamometer driving schedule.

(a) The dynamometer driving schedules are listed in appendix I. The driving schedules are defined by a smooth trace drawn through the specified speed vs. time relationships. They consist of a nonrepetitive series of idle, acceleration, cruise, and deceleration modes of various time sequences and rates. Appropriate driving schedules are as follows:

- Class I—Appendix I(c)
- Class II—Appendix I(b)
- Class III—Appendix I(b)

(b) The speed tolerance at any given time on the dynamometer driving schedule prescribed in appendix I or as printed on a driver's aid chart approved by the Administrator, when conducted to meet the requirements of Sec. 86.537 is defined by upper and lower limits. The upper limit is 3.2 km/h (2 mph) higher than the highest point on the trace within 1 second of the given time. The lower limit is 3.2 km/h (2 mph) lower than the lowest point on the trace within 1 second of the given time. Speed variations greater than the tolerances (such as may occur during gear changes) are acceptable provided they occur for less than 2 seconds on any occasion. Speeds lower than those prescribed are acceptable provided the vehicle is operated at maximum available power during such occurrences. When conducted to meet the requirements of Sec. 86.532 the speed tolerance shall be as specified above, except that the upper and lower limits shall be 6.4 km/h (4 mph).

(c) Figure F78-4 shows the range of acceptable speed tolerances for typical points. Figure F78-4(a) is typical of portions of the speed curve which are increasing or decreasing throughout the two second time interval. Figure F78-4(b) is typical of portions of the speed curve which include a maximum or minimum value.

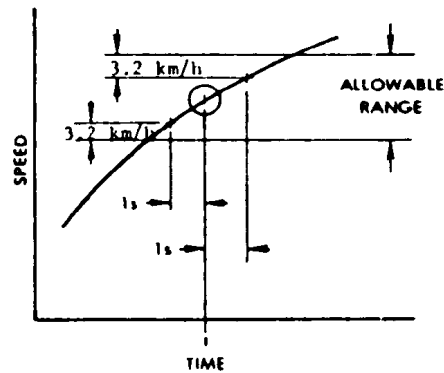

FIGURE F78-4a-DRIVERS TRACE, ALLOWABLE RANGE

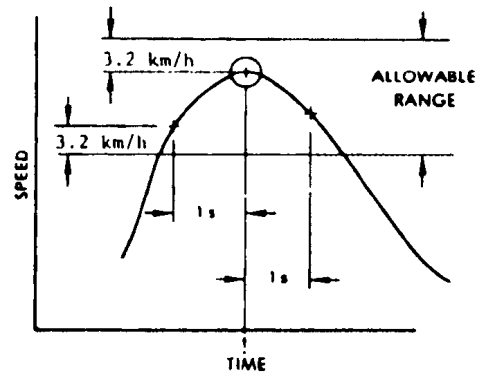

FIGURE F78-4b-DRIVERS TRACE, ALLOWABLE RANGE

§ 86.516-90 Calibrations, frequency and overview.

(a) Calibrations shall be performed as specified in §§ 86.517 through 86.526.

(b) [Reserved]

(c) At least monthly or after any maintenance which could alter calibration, the following calibrations and checks shall be performed:

(1) Calibrate the hydrocarbon analyzer, methane analyzer, carbon dioxide analyzer, carbon monoxide analyzer, and oxides of nitrogen analyzer (certain analyzers may require more frequent calibration depending on particular equipment and uses).

(2) Calibrate the dynamometer. If the dynamometer receives a weekly performance check (and remains within calibration), the monthly calibration need not be performed.

(3) Check the oxides of nitrogen converter efficiency.

(d) At least weekly or after any maintenance which could alter calibration, the following calibrations and checks shall be performed:

(1) [Reserved]

(2) Perform a CVS system verification, and

(3) Run a performance check on the dynamometer. This check may be omitted if the dynamometer has been calibrated within the preceding month.

(e) The CVS positive displacement pump or Critical Flow Venturi shall be calibrated following initial installation, major maintenance or as necessary when indicated by the CVS system verification (described in Sec. 86.519).

(f) Sample conditioning columns, if used in the CO analyzer train, should be checked at a frequency consistent with observed column life or when the indicator of the column packing begins to show deterioration.

[54 FR 14546, Apr. 11, 1989, as amended at 58 FR 58423, Nov. 1, 1993; 60 FR 34354, June 30, 1995]

§ 86.518-78 Dynamometer calibration.

(a) The dynamometer shall be calibrated at least once each month or performance verified at least once each week and then calibrated as required. The dynamometer is driven above the test speed range. The device used to drive the dynamometer is then disengaged from the dynamometer and the roll is allowed to coast down. The kinetic energy of the system is dissipated by the dynamometer. This method neglects the variations in roll bearing friction due to the drive axle weight of the vehicle.

(b) Calibration shall consist of coasting down the dynamometer for each inertia load combination used. Coastdown times for the interval from 70 to 60 km/h shall be within the tolerances specified in Sec. 86.529. The dynamometer adjustments necessary to produce these results shall be noted for future reference.

(c) The performance check consists of conducting a dynamometer coastdown at one or more inertia-horsepower settings and comparing the coastdown time to the table in Figure F98-9 of Sec. 86.529-98. If the coastdown time is outside the tolerance, a new calibration is required.

§ 86.519-78 Constant volume sampler calibration.

The CVS (Constant Volume Sampler) is calibrated using an accurate flowmeter and restrictor valve. Measurements of various parameters are made and related to flow through the unit. Procedures used by EPA for both PDP (Positive Displacement Pump) and CFV (Critical Flow Venturi) are outlined below. Other procedures yielding equivalent results may be used if approved in advance by the Administrator. After the calibration curve has been obtained, verification of the entire system can be performed by injecting a known mass of gas into the system and comparing the mass indicated by the system to the true mass injected. An indicated error does not necessarily mean that the calibration is wrong, since other factors can influence the accuracy of the system, e.g. analyzer calibration. A verification procedure is found in paragraph (c) of this section.

(a) *PDP calibration.* (1) The following calibration procedure outlines the equipment, the test configuration, and the various parameters which must be measured to establish the flow rate of the constant volume sampler pump. All the parameters related to the pump are simultaneously measured with the parameters related to a flowmeter which is connected in series with the pump. The calculated flow rate (at pump inlet absolute pressure and temperature) can then be plotted versus a correlation function which is the value of a specific combination of pump parameters. The linear equation which relates the pump flow and the correlation function is then determined. In the event that a CVS has a multiple speed drive, a calibration for each range used must be performed.

(2) This calibration procedure is based on the measurement of the absolute values of the pump and flowmeter parameters that relate the flow rate at each point. Three conditions must be maintained to assure the accuracy and integrity of the calibration curve. First, the pump pressures should be measured at taps on the pump rather than at the external piping on the pump inlet and outlet. Pressure taps that are mounted at the top center and bottom center of the pump drive headplate are exposed to the actual pump cavity pressures, and therefore reflect the absolute pressure differentials. Secondly, temperature stability must be maintained during the cali-

bration. The laminar flowmeter is sensitive to inlet temperature oscillations which cause the data points to be scattered. Gradual changes (± 1 °C (1.8 °F)) in temperature are acceptable as long as they occur over a period of several minutes. Finally, all connections between the flowmeter and the CVS pump must be absolutely void of any leakage.

(3) During an exhaust emission test the measurement of these same pump parameters enables the user to calculate the flow rate from the calibration equation.

(4) Connect a system as shown in Figure F78-5. Although particular types of equipment are shown, other configurations that yield equivalent results may be used if approved in advance by the Administrator. For the system indicated, the following data with given accuracy are required:

CALIBRATION DATA MEASUREMENTS

Parameter	Symbol	Units	Tolerances
Barometric pressure corrected	P _B	kPa (in. Hg).....	±0.03 kPa (±0.01 in Hg).
Ambient temperature	T _A	°C (°F).....	±0.3 °C (±0.54 °F).
Air Temperature into LFE	ETI.....	°C (°F).....	±0.15 °C (±0.27 °F).
Pressure depression upstream of LFE.....	EPI.....	kPa (in. H ₂ O)	±0.01 kPa (±0.05 in. H ₂ O °F).
Pressure drop across the LFE matrix.....	EDP	kPa (in. H ₂ O)	±0.001 kPa (±0.005 in. H ₂ O).
Air temperature at CVS pump inlet.....	PTI.....	°C (°F).....	±0.25 °C (±0.45 °F).
Pressure depression at CVS pump inlet	PPI.....	kPa (in. Fluid)	±0.021 kPa (±0.046 in Fluid).
Specific gravity of manometer fluid (1.75 oil) . .	Sp. Gr.	±1 Rev.
Pressure head at CVS pump outlet.....	PPO	kPa (in. Fluid)	±0.05 s.
Air temperature at CVS pump outlet (optional)	PTO	°C (°F).....	
Pump revolutions during test period	N.....	Revs	
Elapsed time for test period	t.....	s.....	

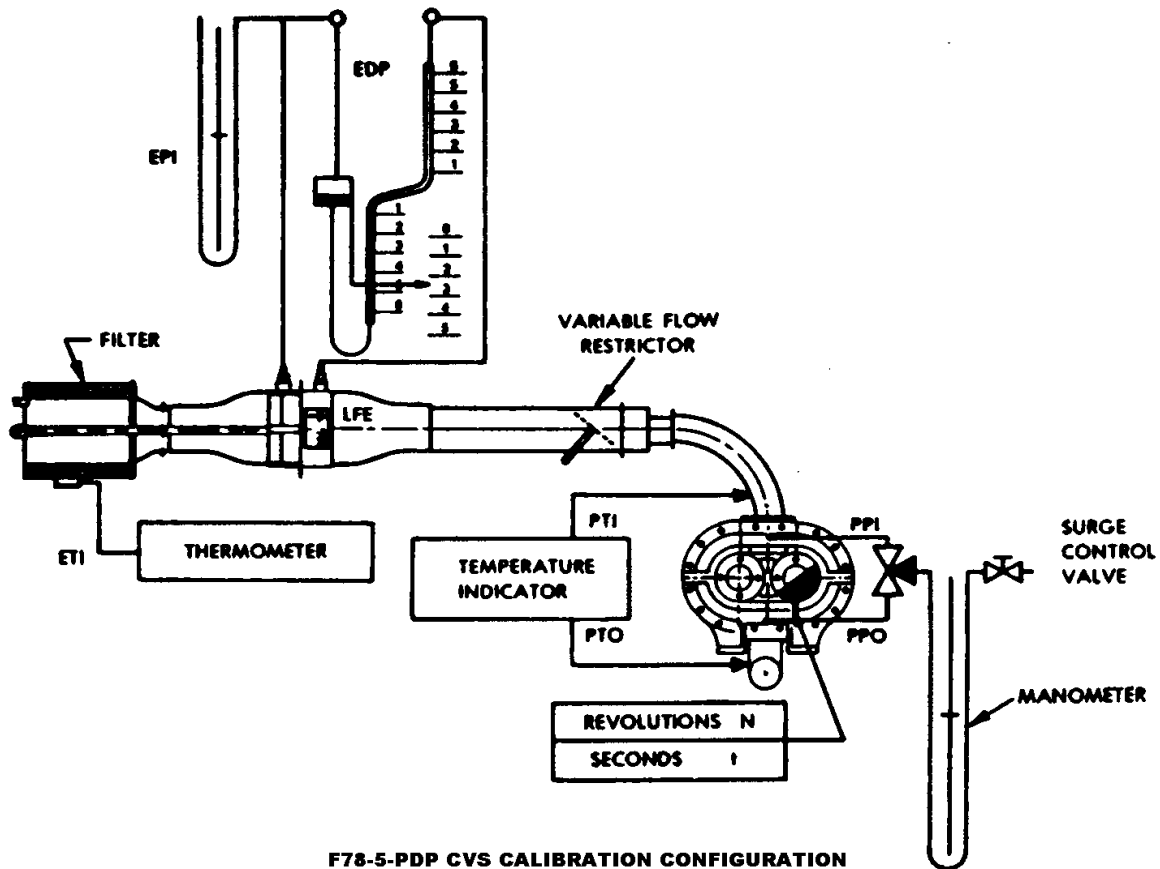

(5) After the system has been connected as shown in Figure F78-5, set the variable restrictor in the wide open position and run the CVS pump for twenty minutes. Record the calibration data.

(6) Reset the restrictor valve to a more restricted condition in an increment of pump inlet depression (about 1.0 kPa (4" H₂O)) that will yield a minimum of six data points for the total calibration. Allow the system to stabilize for 3 minutes and repeat the data acquisition.

(7) *Data analysis:* (i) The air flow rate, Q_s , at each test point is calculated from the flowmeter data using the manufacturer's prescribed method.

(ii) The air flow rate is then converted to pump flow, V_o , per revolution at absolute pump inlet temperature and pressure.

$$V_o = (Q_s/n) \times (T_p/293.15) \times (101.325/P_p)$$

where:

V_o = Pump flow, m³/revolution (ft³/revolution) at T_p , P_p

Q_s = Meter air flow rate in standard cubic metres per minute, standard conditions are 20° C, 101.325 kPa (68 °F, 29.92 in. Hg).

n = Pump speed in revolutions per minute.

T_p = Pump inlet temperature, K(R) = PTI + 273.15 for English units, T_p = PTI + 459.67

P_p = Absolute pump inlet pressure, kPa (in. Hg) = $P_B - PPI$ for English units, P_p = $P_B - PPI$ (SP. GR./13.57)

where:

P_B = barometric pressure, kPa (in. Hg)

PPI = Pump inlet depression, kPa (in. fluid)

SP. GR. = Specific gravity of manometer fluid relative to water.

(iii) The correlation function at each test point is then calculated from the calibration data:

$$X_o = \frac{1}{n} \sqrt{\frac{\Delta P_p}{P_e}}$$

where:

X_o = correlation function.

P_e = The pressure differential from pump inlet to pump outlet, kPa (in. Hg) = $P_e - P_p$

P_e = Absolute pump outlet pressure, kPa (in. Hg) = P_B + PPO for English units, $P_e = P_B + \text{PPO}(\text{SP. GR.}/13.57)$

where:

PPO = Pressure head at pump outlet, kPa (in. fluid)

(iv) A linear least squares fit is performed to generate the calibration equations which have the forms:

$$V_o = D_o - M(X_o)$$

$$n = A - B(P_p)$$

D_o , M , A , and B are the slope-intercept constants describing the lines.

(8) A CVS system that has multiple speeds shall be calibrated on each speed used. The calibration curves generated for the ranges will be approximately parallel and the intercept values, D_o , will increase as the pump flow range decreases.

(9) If the calibration has been performed carefully, the calculated values from the equation will be within ± 0.50 percent of the measured value of V_o . Values of M will vary from one pump to another, but values of D_o for pumps of the same make, model, and range should agree within ± 3 percent of each other. Particulate influx from use will cause the pump slip to decrease as reflected by lower values for M . Calibrations should be performed at pump startup and after major maintenance to assure the stability of the pump slip rate. Analysis of mass injection data will also reflect pump slip stability.

(b) *CFV calibration.* (1) Calibration of the Critical Flow Venturi (CFV) is based upon the flow equation for a critical venturi. Gas flow is a function of inlet pressure and temperature:

$$Q_s = \frac{K_v P}{\sqrt{T}}$$

where:

Q_s = Flow

K_v = Calibration coefficient

P = Absolute pressure

T = Absolute temperature

The calibration procedure described below establishes the value of the calibration coefficient at measured values of pressure, temperature and air flow.

(2) The manufacturer's recommended procedure shall be followed for calibrating electronic portions of the CFV.

(3) Measurements necessary for flow calibration are as follows:

CALIBRATION DATA MEASUREMENTS

Parameter	Symbol	Units	Tolerances
Barometric pressure (corrected).....	P _B	kPa (in. Hg).....	±0.03 kPa (±0.01 in. Hg).
Air Temperature, flowmeter.....	ETI.....	°C (°F).....	±0.15 °C (±0.27 °F).
	EPI.....	kPa (in. H ₂ O).....	
Pressure depression upstream of LFE.....	EDP.....	kPa (in. H ₂ O).....	±0.01 kPa (±0.05 in. H ₂ O).
	Q _s	m ³ min. (ft ³ /min).....	±0.001 kPa (±0.005 in. H ₂ O).
	PPI.....	kPa (in. fluid).....	
Pressure drop across the LFE matrix.....	T _v	°C (°F).....	±0.5%.
Air flow.....	Sp. Gr. .		±0.02 kPa (±0.05 in. fluid). ±0.25 °C (±0.45 °F).
CFV inlet depression.....			
Temperature at venturi inlet.....			
Specific gravity of manometer fluid (1.75 oil).....			

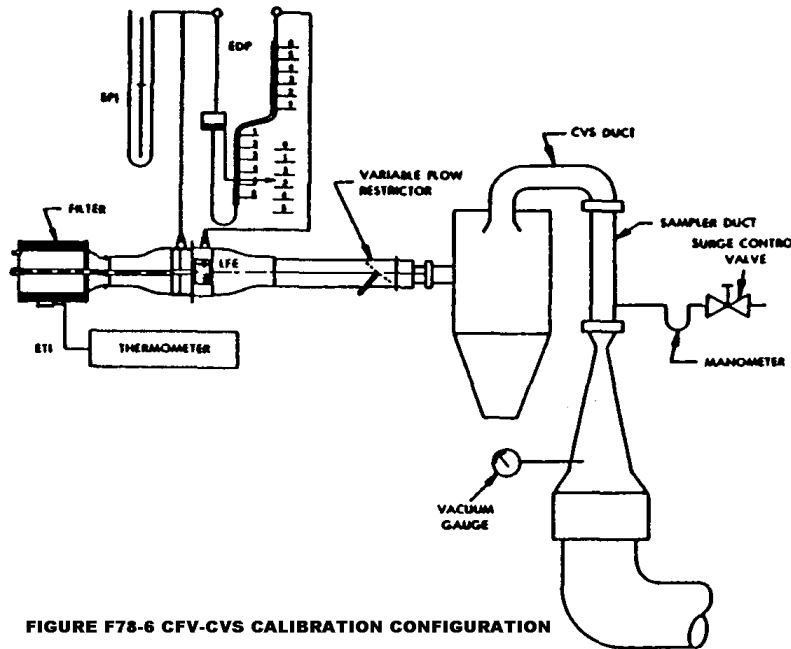

FIGURE F78-6 CFV-CVS CALIBRATION CONFIGURATION

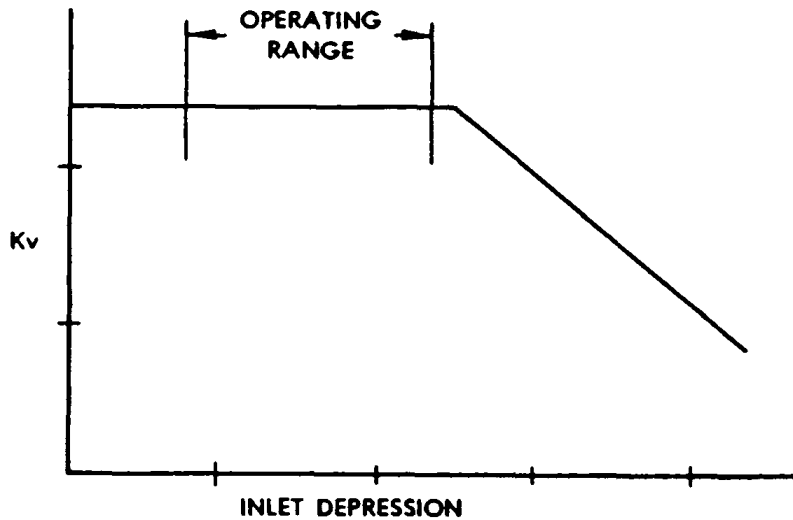

FIGURE F78-7 - SONIC FLOW CHOKING

(4) Set up equipment as shown in Figure F78-6 and check for leaks. Any leaks between the flow measuring device and the critical flow venturi will seriously affect the accuracy of the calibration.

(5) Set the variable flow restrictor to the open position, start the blower and allow the system to stabilize. Record data from all instruments.

(6) Vary the flow restrictor and make at least 8 readings across the critical flow range of the venturi.

(7) *Data analysis.* The data recorded during the calibration are to be used in the following calculations:

(i) The air flow rate, Q_s , at each test point is calculated from the flow meter data using the manufacturer's prescribed method.

(ii) Calculate values of the calibration coefficient for each test point:

$$K_v = \frac{Q_s \sqrt{T_v}}{P_v}$$

where:

Q_s = Flow rate, standard conditions are 20 °C, 101.325 kPa (68 °F, 29.92 in. Hg)

T_v = Temperature at venturi inlet, K(R).

P_v = Pressure at venturi inlet, kPa (mm Hg) = $P_B - PPI$ for English units $P_v = P_B - PPI$ (SP. GR./13.57).

where:

PPI = Venturi inlet pressure depression, kPa (in. fluid).

SP. GR. = Specific gravity of manometer fluid, relative to water.

(iii) Plot K_v as a function of venturi inlet depression. For sonic flow, K_v will have a relatively constant value. As pressure decreases (vacuum increases), the venturi becomes unchoked and K_v decreases (is no longer constant). See Figure F78-7.

(iv) For a minimum of 8 points in the critical region calculate an average K_v and the standard deviation.

(v) If the standard deviation exceeds 0.3 percent of the average K_v take corrective action.

(c) *CVS System Verification.* The following "gravimetric" technique can be used to verify that the CVS and analytical instruments can accurately measure a mass of gas that has been injected into the system. (Verification can also be accomplished by constant flow metering using critical flow orifice devices.)

(1) Obtain a small cylinder that has been charged with pure propane or carbon monoxide gas (caution—carbon monoxide is poisonous).

(2) Determine a reference cylinder weight to the nearest 0.01 grams.

(3) Operate the CVS in the normal manner and release a quantity of pure propane or carbon monoxide into the system during the sampling period (approximately 5 minutes).

(4) The calculations of § 86.544 are performed in the normal way except in the case of propane. The density of propane (0.6109 kg/m³/carbon atom (17.30 g/ft³/carbon atom)) is used in place of the density of exhaust hydrocar-

bons. In the case of carbon monoxide, the density of 1.164 kg/m³ (32.97 g/ft³) is used.

(5) The gravimetric mass is subtracted from the CVS measured mass and then divided by the gravimetric mass to determine the percent accuracy of the system.

(6) The cause for any discrepancy greater than ±2 percent must be found and corrected.

[42 FR 1137, Jan. 5, 1977, as amended at 42 FR 56738, Oct. 28, 1977]

§ 86.519-90 Constant volume sampler calibration.

(a) The CVS (Constant Volume Sampler) is calibrated using an accurate flowmeter and restrictor valve. Measurements of various parameters are made and related to flow through the unit. Procedures used by EPA for both PDP (Positive Displacement Pump) and CFV (Critical Flow Venturi) are outlined below. Other procedures yielding equivalent results may be used if approved in advance by the Administrator. After the calibration curve has been obtained, verification of the entire system can be performed by injecting a known mass of gas into the system and comparing the mass indicated by the system to the true mass injected. An indicated error does not necessarily mean that the calibration is wrong, since other factors can influence the accuracy of the system, e.g., analyzer calibration. A verification procedure is found in paragraph (d) of this section.

(b) *PDP calibration.* (1) The following calibration procedures outlines the equipment, the test configuration, and the various parameters which must be measured to establish the flow rate of the constant volume sampler pump. All the parameters related to the pump are simultaneously measured with the parameters related to a flowmeter which is connected in series with the pump. The calculated flow rate (at pump inlet absolute pressure and temperature) can then be plotted versus a correlation function which is the value of a specific combination of pump parameters. The linear equation which relates the pump flow and the correlation function is then determined. In the event that a CVS has a

multiple speed drive, a calibration for each range must be performed.

(2) This calibration procedure is based on the measurement of the absolute values of the pump and flowmeter parameters that relate the flow rate at each point. Three conditions must be maintained to assure the accuracy and integrity of the calibration curve. First, the pump pressures should be measured at taps on the pump rather than at the external piping on the pump inlet and outlet. Pressure taps that are mounted at the top center and bottom center of the pump drive headplate are exposed to the actual pump cavity pressures, and therefore reflect the absolute pressure differentials. Secondly, temperature stability must be maintained during the calibration. The laminar flowmeter is sensitive to inlet temperature oscillations which cause the data points to be scattered. Gradual changes (± 1 °C (± 1.8 °F)) in temperature are acceptable as long as they occur over a period of several minutes. Finally, all connections between the flowmeter and the CVS pump must be absolutely void of any leakage.

(3) During an exhaust emission test the measurement of these same pump parameters enables the user to calculate the flow rate from the calibration equation.

(4) Connect a system as shown in Figure F78-5. Although particular types of equipment are shown, other configurations that yield equivalent results may be used if approved in advance by the Administrator. For the system indicated, the following data with given accuracy are required:

CALIBRATION DATA MEASUREMENTS

Parameter	Symbol	Units	Tolerances
Barometric pressure (corrected).....	P _B	kPa (in. Hg).....	±0.03 kPa (±0.01 in. Hg).
Ambient temperature	T _A	°C (°F).....	±0.3 °C (±0.54 °F).
	ETI.....	°C (°F).....	
Air Temperature into LFE	EPI.....	kPa (in. H ₂ O)	±0.15 °C (±0.27 °F).
	EDP	kPa (in. H ₂ O)	±0.01 kPa (±0.05 in. H ₂ O).
	PTI.....	°C (°F).....	
Pressure depression upstream of LFE.....	PPI.....	kPa (in. Fluid)	±0.001 kPa (±0.005 in. H ₂ O).
	Sp. Gr.		
Pressure drop across the LFE matrix.....	PPO.....	kPa (in. Fluid)	±0.25 °C (±0.45 °F).
	PTO.....	°C (°F).....	
Air temperature at CVS pump inlet.....	N.....	Revs	±0.02 kPa (±0.05 in. Fluid).
	t.....	sec.	
Pressure depression at CVS pump inlet			±0.21 kPa (±0.46 in. Fluid).
Specific gravity of manometer fluid (1.75 oil) . .			±0.25 °C (±0.45 °F).
Pressure head at CVS pump outlet.....			± 1 Rev.
			±0.5% sec.
Air Temperature at CVS pump outlet (optional)			
Pump revolutions during test period			
Elapsed time for test period			

(5) After the system has been connected as shown in Figure F78-6, set the variable restrictor in the wide open position and run the CVS pump for twenty minutes. Record the calibration data.

(6) Reset the restrictor valve to a more restricted condition in an increment of pump inlet depression (about 1.0 kPa (4 in. H₂O)) that will yield a minimum of six data points for the total calibration. Allow the system to stabilize for 3 minutes and repeat the data acquisition.

(7) Data analysis:

(i) The air flow rate, Q_s, at each test point is calculated from the flowmeter data using the manufacturers' prescribed method.

(ii) The air flow rate is then converted to pump flow, V_o in m³ per revolution at absolute pump inlet temperature and pressure.

$$V_o = (Q_s/n) \times (T_p/293) \times (101.3/P_p)$$

Where:

(A) V_o = Pump flow, m³/rev (ft³/rev) at T_p, P_p.

(B) Q_s = Meter air flow rate in standard cubic meters per minute; standard conditions are 20 °C, 101.3 kPa (68 °F, 29.92 in. Hg).

(C) n = Pump speed in revolutions per minute.

(D)(1) T_p = Pump inlet temperature, (°K) = PTI + 273.

(2) For English units, T_p = PTI + 460.

(E)(1) P_p = Absolute pump inlet pressure, kPa (in. Hg) = P_B - PPI.

(2) For English units, P_p = P_B - PPI(SP.GR./13.57).

Where:

(F) P_B = barometric pressure, kPa (in. Hg.).

(G) PPI = Pump inlet depression, kPa (in. fluid).

(H) SP.GR. = Specific gravity of manometer fluid relative to water.

(iii) The correlation function at each test point is then calculated from the calibration data:

$$X_o = \frac{1}{n} \sqrt{\frac{\Delta P_p}{P_e}}$$

Where:

(A) X_o = correlation function.

(B) Δ P_p = The pressure differential from pump inlet to pump outlet, kPa (in. Hg) = P_e - P_p.

(C)(1) P_e = Absolute pump outlet pressure, kPa (in. Hg) = P_B + PPO.

(2) For English units, P_e = P_B + PPO(SP.GR./13.57).

Where:

(D) PPO = Pressure head at pump outlet, kPa (in. fluid).

(iv) A linear least squares fit is performed to generate the calibration equations which have the forms:

$$V_o = D_o - M(X_o)$$

$$n = A - B(\Delta P_p)$$

D_o , M , A , and B are the slope-intercept constants, describing the lines.

(8) A CVS system that has multiple speeds shall be calibrated on each speed used. The calibration curves generated for the ranges will be approximately parallel and the intercept values, D_o , will increase as the pump flow range decreases.

(9) If the calibration has been performed carefully, the calculated values from the equation will be within ± 0.50 percent of the measured value of V_o . Values of M will vary from one pump to another, but values of D_o for pumps of the same make, model, and range should agree within ± 3 percent of each other. Particulate influx from use will cause the pump slip to decrease as reflected by lower values for M . Calibrations should be performed at pump startup and after major maintenance to assure the

stability of the pump slip rate. Analysis of mass injection data will also reflect pump slip stability.

(c) *CFV calibration.* (1) Calibration of the Critical Flow Venturi (CFV) is based upon the flow equation for a critical venturi. Gas flow is a function of inlet pressure and temperature:

$$Q_s = \frac{K_v P}{\sqrt{T}}$$

Where:

- (i) Q_s = Flow.
- (ii) K_v = Calibration coefficient.
- (iii) P = Absolute pressure.
- (iv) T = Absolute temperature.

The calibration procedure described below establishes the value of the calibration coefficient at the measured values of pressure, temperature and air flow.

(2) The manufacturer's recommended procedure shall be followed for calibrating electronic portions of the CFV.

(3) Measurements necessary for flow calibration are as follows:

CALIBRATION DATA MEASUREMENTS

Parameter	Symbol	Units	Tolerances
Barometric pressure (corrected).....	P_B	kPa (in. Hg).....	± 0.03 kPa (± 0.01 in.Hg).
Air temperature, flowmeter	ETI.....	$^{\circ}\text{C}$ ($^{\circ}\text{F}$).....	± 0.15 $^{\circ}\text{C}$ (± 0.27 $^{\circ}\text{F}$).
Pressure depression upstream of LFE.....	EPI.....	kPa (in. H ₂ O)	± 0.01 kPa $^{\circ}\text{C}$ (± 0.05 in. H ₂ O).
Pressure drop across the LFE matrix.....	EDP	kPa (in. H ₂ O)	± 0.001 kPa (± 0.005 in. H ₂ O).
Air flow	Q_s	m^3/min (ft^3/min).....	$\pm 0.5\%$
CFV inlet depression	PPI.....	kPa (in. Fluid)	± 0.02 kPa (± 0.05 in. fluid).
Temperature at venturi inlet.....	T_v	$^{\circ}\text{C}$ ($^{\circ}\text{F}$).....	± 0.25 $^{\circ}\text{C}$ (± 0.45 $^{\circ}\text{F}$).
Specific gravity of manometer fluid (1.75 oil).....	Sp Gr

(4) Set up equipment as shown in Figure F78-6 and check for leaks. Any leaks between the flow measuring device and the critical flow venturi will seriously affect the accuracy of the calibration.

(5) Set the variable flow restrictor to the open position, start the blower and allow the sys-

tem to stabilize. Record data from all instruments.

(6) Vary the flow restrictor and make at least 8 readings across the critical flow range of the venturi.

(7) *Data analysis.* The data recorded during the calibration are to be used in the following calculations:

(i) The air flow rate, Q_s , at each test point is calculated from the flowmeter data using the manufacturer's prescribed method.

(ii) Calculate values of the calibration coefficient for each test point:

$$K_v = \frac{Q_s \sqrt{T_v}}{P_v}$$

Where:

(A) Q_s = Flow rate in m^3/minute , standard conditions are 20 °C, 101.3 kPa (68 °F, 29.92 in. Hg)

(B) T_v = Temperature at venturi inlet, °K(°R).

(C)(1) P_v = Pressure at venturi inlet, kPa (mm Hg) = $P_B - \text{PPI}$.

(2) For English units, $P_v = P_B - \text{PPI}$ (SP.GR./13.57).

Where:

(D) PPI = Venturi inlet pressure depression, kPa (in. fluid).

(E) SP.GR.=Specific gravity of manometer fluid, relative to water.

(iii) Plot K_v as a function of venturi inlet depression. For sonic flow, K_v will have a relatively constant value. As pressure decreases (vacuum increases), the venturi becomes unchoked and K_v decreases (is no longer constant). See Figure F78-7.

(iv) For a minimum of 8 points in the critical region, calculate an average K_v and the standard deviation.

(v) If the standard deviation exceeds 0.3 percent of the average K_v , take corrective action.

(d) *CVS system verification.* The following "gravimetric" technique can be used to verify that the CVS and analytical instruments can accurately measure a mass of gas that has been injected into the system. If the CVS and analytical system will be used only in the testing of gasoline-fueled vehicles, the system verification may be performed using either propane or carbon monoxide. If the CVS and analytical system will be used with methanol-fueled vehicles as well as gasoline-fueled vehicles, system verification performance check must include a metha-

nol check in addition to either the propane or carbon monoxide check. (Verification can also be accomplished by constant flow metering using critical flow orifice devices.)

(1) Obtain a small cylinder that has been charged with pure propane or carbon monoxide gas (CAUTION—carbon monoxide is poisonous).

(2) Determine a reference cylinder weight to the nearest 0.01 grams.

(3) Operate the CVS in the normal manner and release a quantity of pure propane or carbon monoxide into the system during the sampling period (approximately 5 minutes).

(4) Following completion of step (3) above (if methanol injection is required), continue to operate the CVS in the normal manner and release a known quantity of pure methanol (in gaseous form) into the system during the sampling period (approximately 5 minutes). This step does not need to be performed with each verification, provided that it is performed at least twice annually.

(5) The calculations of § 86.544 are performed in the normal way except in the case of propane. The density of propane (0.6109 kg/m^3 /carbon atom (17.30 g/ft^3 /carbon atom)) is used in place of the density of exhaust hydrocarbons. In the case of carbon monoxide, the density of 1.164 kg/m^3 (32.97 g/ft^3) is used. In the case of methanol, the density of 1.332 kg/m^3 (37.71 g/ft^3) is used.

(6) The gravimetric mass is subtracted from the CVS measured mass and then divided by the gravimetric mass to determine the percent accuracy of the system.

(7) The cause for any discrepancy greater than ± 2 percent must be found and corrected. The Administrator, upon request, may waive the requirement to comply with ± 2 percent methanol recovery tolerance, and instead require compliance with a higher tolerance (not to exceed ± 6 percent), provided that:

(i) The Administrator determines that compliance with the specified tolerance is not practically feasible; and

(ii) The manufacturer makes information available to the Administrator which indicates that the calibration tests and their results are

consistent with good laboratory practice, and that the results are consistent with the results of calibration testing conducted by the Administrator.

[54 FR 14546, Apr. 11, 1989, as amended at 60 FR 34355, June 30, 1995]

§ 86.521-90 Hydrocarbon analyzer calibration.

(a) The FID hydrocarbon analyzer shall receive the following initial and periodic calibration. The HFID used with methanol-fueled vehicles shall be operated at 235 °F±15 °F (113 °C±8 °C).

(b) *Initial and periodic optimization of detector response.* Prior to its introduction into service and at least annually thereafter, the FID hydrocarbon analyzer shall be adjusted for optimum hydrocarbon response. Analyzers used with petroleum fuels and liquefied petroleum gas-fuel shall be optimized using propane. Analyzers used with natural gas-fuel for measurement of hydrocarbons shall be optimized using methane. If a single analyzer is used for all measurements, it shall be optimized using propane and its response factor for methane shall be determined and accounted for in measurements of total hydrocarbons from natural gas-fuel. Alternate methods yielding equivalent results may be used, if approved in advance by the Administrator.

(1) Follow the manufacturer's instructions or good engineering practice for instrument startup and basic operating adjustment using the appropriate FID fuel and zero-grade air.

(2) Optimize on the most common operating range. Introduce into the analyzer a propane (methane as appropriate) in air mixture (methanol in air mixture for methanol-fueled vehicles when optional methanol calibrated FID procedure is used during the 1990 through 1994 model year) with a propane (or methane or methanol as appropriate) concentration equal to approximately 90 percent of the most common operating range.

(3) Select an operating FID fuel flow rate that will give near maximum response and

least variation in response with minor fuel flow variations.

(4) To determine the optimum air flow, use the FID fuel flow setting determined above and vary air flow.

(5) After the optimum flow rates have been determined, record them for future reference.

(c) *Initial and periodic calibration.* Prior to its introduction into service and monthly thereafter the FID hydrocarbon analyzer shall be calibrated on all normally used instrument ranges, and, if applicable, the methanol response factor shall be determined (paragraph (d) of this section). Use the same flow rate as when analyzing sample.

(1) Adjust analyzer to optimize performance.

(2) Zero the hydrocarbon analyzer with zero grade air.

(3) Calibrate on each normally used operating range with propane in air (or methanol or methane in air as appropriate) calibration gases having nominal concentrations of 15, 30, 45, 60, 75 and 90 percent of that range. For each range calibrated, if the deviation from a least squares best-fit straight line is two percent or less of the value at each data point, concentration values may be calculated by use of a single calibration factor for that range. If the deviation exceeds two percent at any point, the best-fit non-linear equation which represents the data to within two percent of each test point shall be used to determine concentration.

(d) *FID response factor to methanol.* When the FID analyzer is to be used for the analysis of hydrocarbon samples containing methanol, the methanol response factor of the analyzer shall be established. The methanol response factor shall be determined at several concentrations in the range of concentrations in the exhaust sample, using either bag samples or gas bottles meeting the requirements of Sec. 86.514.

(1) The bag sample, if used, of methanol for analysis in the FID shall be prepared using the apparatus shown in Figure F90-4. A known volume of methanol is injected, using a microliter syringe, into the heated mixing zone (250 °F (121 °C)) of the apparatus. The methanol is va-

porized and swept into the sample bag with a known volume of zero grade air measured by a gas flow meter meeting the performance requirements of Sec. 86.120.

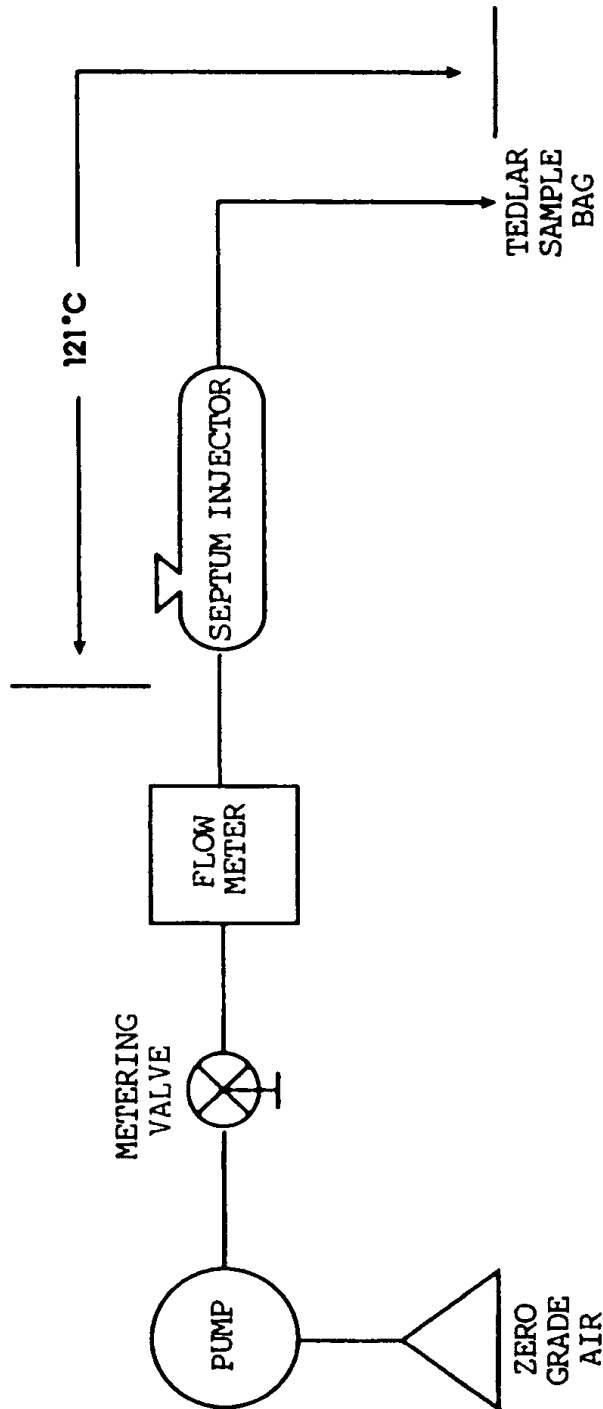

FIGURE F90-4 APPARATUS FOR PREPARATION OF FID METHANOL RESPONSE CALIBRATION MIX

(2) The bag sample is analyzed using the FID.

(3) The FID response factor, r , is calculated as follows:

$$r = \text{FID}_{\text{ppm}} / \text{SAM}_{\text{ppm}}$$

Where:

- (i) r = FID response factor.
- (ii) FID_{ppm} = FID reading, ppmC.
- (iii) SAM_{ppm} = methanol concentration in the sample bag, or gas bottle, in ppmC. SAM_{ppm} for sample bags:

$$= \frac{0.02406 \times \text{Fuel injected} \times \text{Fuel density}}{\text{Air volume} \times \text{Mol. Wt. CH}_3\text{OH}}$$

Where:

- (iv) 0.02406 = Volume of one mole at 101.3 kPa (29.92 in. Hg) and 20 °C (68 °F), m³.
- (v) Fuel injected = Volume of methanol injected, ml.
- (vi) Fuel Density = Density of methanol, 0.7914 g/ml
- (vii) Air volume = Volume of zero grade air, m³
- (viii) Mol. Wt. CH₃OH = 32.04
- (e) *FID response factor to methane.*

When the FID analyzer is to be used for the analysis of natural gas-fueled motorcycle hydrocarbon samples, the methane response factor of the analyzer shall be established. To determine the total hydrocarbon FID response to methane, known methane in air concentrations traceable to National Institute of Standards and Technology (NIST) shall be analyzed by the FID. Several methane concentrations shall be analyzed by the FID in the range of concentrations in the exhaust sample. The total hydrocarbon FID response to methane is calculated as follows:

$$r_{\text{CH}_4} = \text{FID}_{\text{ppm}} / \text{SAM}_{\text{ppm}}$$

Where:

- (1) r_{CH_4} = FID response factor to methane.
- (2) FID_{ppm} = FID reading in ppmC.
- (3) SAM_{ppm} = the known methane concentration in ppmC.

[54 FR 14546, Apr. 11, 1989, as amended at 59 FR 48514, Sept. 21, 1994; 60 FR 34355, June 30, 1995]

§ 86.522-78 Carbon monoxide analyzer calibration.

(a) *Initial and periodic interference check.* Prior to its introduction into service and annually thereafter the NDIR carbon monoxide analyzer shall be checked for response to water vapor and CO₂.

(1) Follow the manufacturer's instructions for instrument startup and operation. Adjust the analyzer to optimize performance on the most sensitive range.

(2) Zero the carbon monoxide analyzer with either zero grade air or zero grade nitrogen.

(3) Bubble a mixture of 3 percent CO₂ in N₂ through water at room temperature and record analyzer response.

(4) An analyzer response of more than 1 percent of full scale for ranges above 300 ppm full scale or of more than 3 ppm on ranges below 300 ppm full scale will require corrective action. (Use of conditioning columns is one form of corrective action which may be taken.)

(b) *Initial and periodic calibration.* Prior to its introduction into service and monthly thereafter the NDIR carbon monoxide analyzer shall be calibrated.

(1) Adjust the analyzer to optimize performance.

(2) Zero the carbon monoxide analyzer with either zero grade air or zero grade nitrogen.

(3) Calibrate on each normally used operating range with carbon monoxide in N₂ calibration gases having nominal concentrations of 15, 30, 45, 60, 75, and 90 percent of that range. Additional calibration points may be generated. For each range calibrated, if the deviation from a least-squares best-fit straight line is 2 percent or less of the value at each data point, concentration values may be calculated by use of a single calibration factor for that range. If the deviation exceeds 2 percent at any point, the best-fit non-linear equation which represents the data to within 2 percent of each test point shall be used to determine concentration.

§ 86.523-78 Oxides of nitrogen analyzer calibration.

(a) Prior to introduction into service and at least monthly thereafter, if oxides of nitrogen are measured, the chemiluminescent oxides of

nitrogen analyzer must be checked for NO₂ to NO converter efficiency. Figure F78-8 is a reference for paragraphs (a) (1) through (11) of this section.

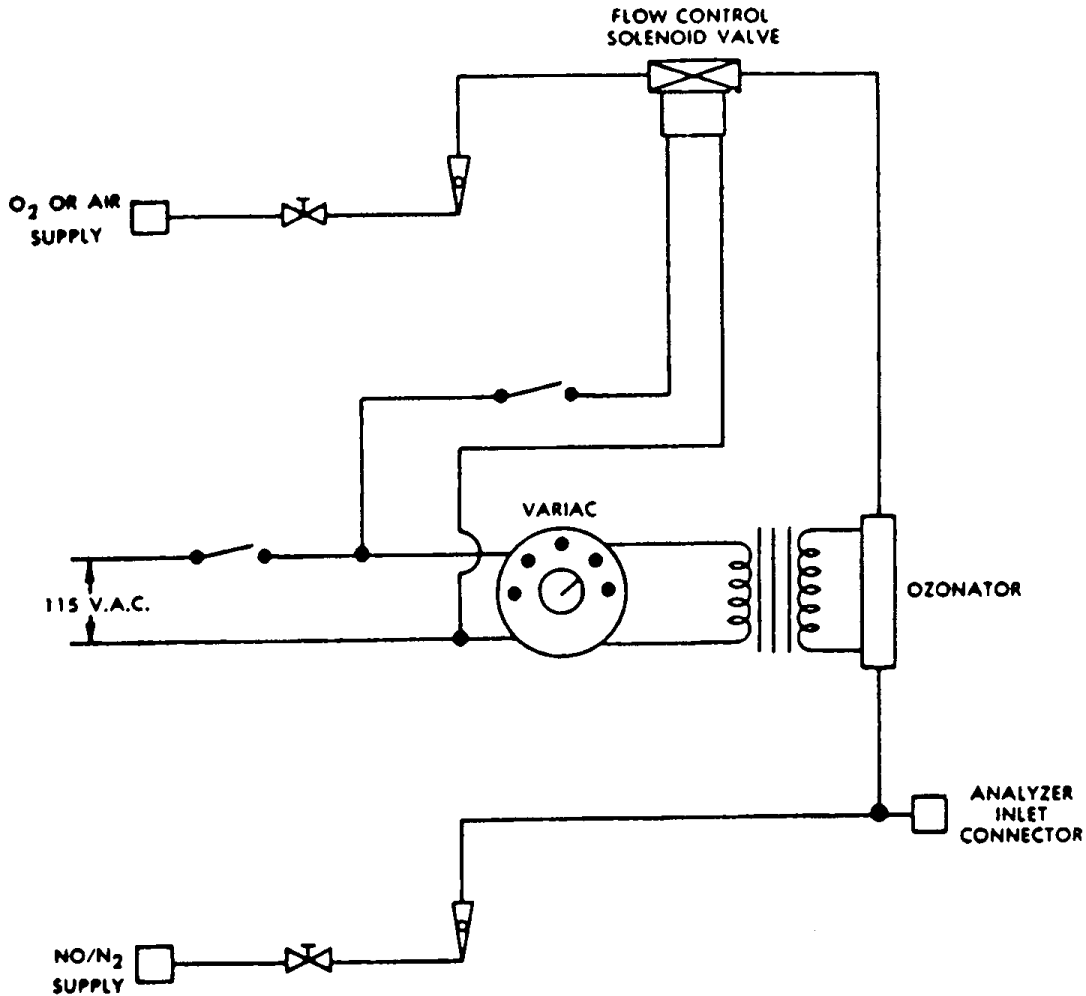

(SEE FIG F78-3 FOR SYMBOL LEGEND)
FIGURE F78-8 NO_x CONVERTER EFFICIENCY DETECTOR

(1) Follow the manufacturer's instructions for instrument startup and operation. Adjust the analyzer to optimize performance.

(2) Zero the oxides of nitrogen analyzer with zero grade air or zero grade nitrogen.

(3) Connect the outlet of the NO_x generator to the sample inlet of the oxides of nitrogen analyzer which has been set to the most common operating range.

(4) Introduce into the NO_x generator analyzer-system a NO in nitrogen (N₂) mixture with a NO concentration equal to approximately 80 percent of the most common operating range.

The NO₂ content of the gas mixture shall be less than 5 percent of the NO concentration.

(5) With the oxides of nitrogen analyzer in the NO mode, record the concentration of NO indicated by the analyzer.

(6) Turn on the NO_x generator O₂ (or air) supply and adjust the O₂ (or air) flow rate so that the NO indicated by the analyzer is about 10 percent less than indicated in step 5. Record the concentration of NO in this NO + O₂ mixture.

(7) Switch the NO_x generator to the generation mode and adjust the generation rate so that the NO measured on the analyzer is 20

percent of that measured in step 5. There must be at least 10 percent unreacted NO at this point. Record the concentration of residual NO.

(8) Switch the oxides of nitrogen analyzer to the NO_x mode and measure total NO_x. Record this value.

(9) Switch off the NO_x generation but maintain gas flow through the system. The oxides of nitrogen analyzer will indicate the NO_x in the NO + O₂ mixture. Record this value.

(10) Turn off the NO_x generator O₂ (or air) supply. The analyzer will now indicate the NO_x in the original NO in N₂ mixture. This value should be no more than 5 percent above the value indicated in step 4.

(11) Calculate the efficiency of the NO_x converter by substituting the concentrations obtained into the following equation:

$$\text{Percent Efficiency} = [1 + (a-b)/(c-d)] \times 100$$

where:

a = concentration obtained in step (8).

b = concentration obtained in step (9).

c = concentration obtained in step (6).

d = concentration obtained in step (7).

If converter efficiency is not greater than 90 percent corrective action will be required.

(b) Initial and periodic calibration. Prior to its introduction into service and monthly thereafter, if oxides of nitrogen are measured, the chemiluminescent oxides of nitrogen analyzer shall be calibrated on all normally used instrument ranges. Use the same flow rate as when analyzing samples. Proceed as follows:

(1) Adjust analyzer to optimize performance.

(2) Zero the oxides of nitrogen analyzer with zero grade air or zero grade nitrogen.

(3) Calibrate on each normally used operating range with NO in N₂ calibration gases with nominal concentrations of 50 and 100 percent of that range. Additional calibration points may be generated.

(c) When testing methanol-fueled motorcycles, it may be necessary to clean the analyzer frequently to prevent interference with NO_x measurements (see EPA/600/S3-88/040).

[42 FR 1137, Jan. 5, 1977, as amended at 52 FR 47870, Dec. 16, 1987; 58 FR 58423, Nov. 1, 1993; 60 FR 34357, June 30, 1995]

§ 86.524-78 Carbon dioxide analyzer calibration.

(a) Prior to its introduction into service and monthly thereafter the NDIR carbon dioxide analyzer shall be calibrated:

(1) Follow the manufacturer's instructions for instrument startup and operation. Adjust the analyzer to optimize performance.

(2) Zero the carbon dioxide analyzer with either zero grade air or zero grade nitrogen.

(3) Calibrate on each normally used operating range with carbon dioxide in N₂ calibration gases with nominal concentrations of 15, 30, 45, 60, 75, and 90 percent of that range. Additional calibration points may be generated. For each range calibrated, if the deviation from a least-squares best-fit straight line is 2 percent or less of the value at each data point, concentration values may be calculated by use of a single calibration factor for that range. If the deviation exceeds 2 percent at any point, the best-fit non-linear equation which represents the data to within 2 percent of each test point shall be used to determine concentration.

(b) [Reserved]

§ 86.526-90 Calibration of other equipment.

Other test equipment used for testing shall be calibrated as often as required by the manufacturer or as necessary according to good practice. Specific equipment requiring calibration is the gas chromatograph and flame ionization detector used in measuring methanol and the high pressure liquid chromatograph (HPLC) and ultraviolet detector for measuring formaldehyde.

[54 FR 14551, Apr. 11, 1989]

§ 86.527-90 Test procedures, overview.

(a) The procedures described in this and subsequent sections are used to determine the conformity of motorcycles with the standards set forth in subpart E of this part.

(b) The overall test consists of prescribed sequences of fueling, parking, and operating conditions.

(c) The exhaust emission test is designed to determine hydrocarbon (gasoline-fueled, natural gas-fueled and liquefied petroleum gas-fueled motorcycles), methanol, formaldehyde, and hydrocarbon (methanol-fueled motorcycles), carbon monoxide and oxides of nitrogen mass emissions while simulating an average trip in an urban area. The test consists of engine startups and motorcycle operation on a chassis dynamometer, through a specified driving schedule. A proportional part of the diluted exhaust emissions is collected continuously for subsequent analysis, using a constant volume (variable dilution) sampler.

(d) Except in cases of component malfunction or failure, all emission control systems installed on or incorporated in a new motorcycle shall be functioning during all procedures in this subpart. Maintenance to correct component malfunction or failure shall be authorized in accordance with subpart E of this part.

(e) Background concentrations are measured for all species for which emissions measurements are made. For exhaust testing, this requires sampling and analysis of the dilution air. (When testing methanol-fueled motorcycles, manufacturers may choose not to measure background concentrations of methanol and/or formaldehyde, and then assume that the concentrations are zero during calculations.)

[54 FR 14551, Apr. 11, 1989, as amended at 59 FR 48515, Sept. 21, 1994; 60 FR 34357, June 30, 1995]

§ 86.528-78 Transmissions.

(a) Vehicles equipped with transfer cases, multiple sprockets, etc., shall be tested in the manufacturer's recommended configuration for street or highway use. If more than one configuration is recommended or if the recommendation is deemed unreasonable by the Administrator,

the Administrator will specify the test configuration.

(b) All tests shall be conducted with automatic transmissions in "Drive" (highest gear). Automatic clutch-torque converter transmissions may be shifted as manual transmissions at the option of the manufacturer.

(c) Idle modes shall be run with automatic transmissions in "Drive" and the wheels braked, manual transmission shall be in gear with the clutch disengaged; except first idle, see §§ 86.536 and 86.537.

(d) The vehicle shall be driven with minimum throttle movement to maintain the desired speed. No simultaneous use of brake and throttle shall be permitted.

(e) Acceleration modes shall be driven smoothly. Automatic transmissions shall shift automatically through the normal sequence of gears; manual transmissions shall be shifted as recommended by the manufacturer to the ultimate purchaser (unless determined to be unreasonable by the Administrator) with the operator closing the throttle during each shift and accomplishing the shift with minimum time. If the vehicle cannot accelerate at the specified rate, the vehicle shall be operated with the throttle fully opened until the vehicle speed reaches the value prescribed for that time in the driving schedule.

(f) The deceleration modes shall be run in gear using brakes or throttle as necessary to maintain the desired speed. Manual transmission vehicles shall be downshifted using the same shift points as when upshifting or as recommended by the manufacturer in the vehicle owner's manual. All downshifts shall be made smoothly, disengaging the clutch while shifting and engaging the clutch once the lower gear has been selected. For those modes which require the vehicle to decelerate to zero, manual transmission clutches shall be disengaged when the speed drops below 15 km/h (9.3 mph) for vehicles with engine displacements equal to or greater than 280 cc (17.1 cu. in.), when the speed drops below 10 km/h (6.2 mph) for vehicles with engine displacements less than 280 cc (17.1 cu. in.), when engine roughness is evident, or when engine stalling is imminent.

(g) If downshifting during deceleration is not permitted in the vehicle owner's manual, manual transmissions will be downshifted at the beginning of or during a power mode if recommended by the manufacturer or if the engine obviously is lugging. For those modes which require these vehicles to decelerate to zero, manual transmission clutches shall be disengaged when the speed drops below 25 km/h (15.5 mph) for vehicles with engine displacement equal to or greater than 280 cc (17.1 cu. in.), when the speed drops below 20 km/h (12.4 mph) for vehicles with engine displacements less than 280 cc (17.1 cu. in.), when engine roughness is evident, or when engine stalling is imminent. While the clutch is disengaged and during these deceleration modes, the vehicle shall be shifted to the appropriate gear for starting the next mode.

(h) If shift speeds are not recommended by the manufacturer, manual transmission vehicles shall be shifted as follows:

(1) For Class I and II motorcycles:

Shift	Speed
1st to 2d gear.....	19 km/h (11.8 mi/h).
2d to 3d gear.....	33 km/h (20.5 mi/h).
3d to 4th gear.....	44 km/h (27.3 mi/h).
4th to 5th gear.....	53 km/h (32.9 mi/h).

(2) For Class III motorcycles:

Shift	Speed
1st to 2d gear.....	30 km/h (18.6 mi/h).
2d to 3d gear.....	45 km/h (28.0 mi/h).
3d to 4th gear.....	60 km/h (37.3 mi/h).
4th to 5th gear.....	75 km/h (46.6 mi/h).

(3) Higher gears may be used at the manufacturer's option.

§ 86.529-78 Road load force and inertia weight determination.

(a) Road load as a function of speed is given by the following equation:

$$F = A + CV^2$$

The values for coefficients *A* and *C* and the test inertia are given in Figure F78-9. Velocity (*V*) is in km/h and force (*F*) is in newtons. The forces

given by this equation shall be simulated to the best ability of the equipment being used.

(b) The inertia given in Figure F78-9 shall be used. Motorcycles with loaded vehicle mass outside these limits shall be tested at an equivalent inertial mass and road load force specified by the Administrator.

FIGURE F78-9

☐ Loaded vehicle mass (kg)	Equivalent inertial mass (kg)	Force coefficients		Force at 65 km/h (nt)	70 to 60 kn/h coastdown calibration times		
		A (nt)	C (nt/(km/h) ²)		Target time (sec)	Allowable tolerance	
						Longest time (sec)	Shortest time (sec)
95-105	100	0.0	0.224	94.8	2.95	3.1	2.8
106-115	110	0.82	.0227	96.8	3.18	3.3	3.0
116-125	120	1.70	.0230	98.8	3.39	3.6	3.2
126-135	130	2.57	.0233	100.9	3.60	3.8	3.4
136-145	140	3.44	.0235	102.9	3.80	4.0	3.6
146-155	150	4.32	0.230	104.9	3.99	4.2	3.8
156-165	160	5.19	.0241	107.0	4.10	4.4	4.0
166-175	170	6.06	.0244	109.0	4.36	4.6	4.2
176-185	180	6.94	.0246	111.0	4.53	4.7	4.3
186-195	190	7.81	.0249	113.1	4.69	4.9	4.5
196-205	200	8.69	.0252	115.1	4.85	5.1	4.6
206-215	210	9.56	.0255	117.1	5.00	5.2	4.8
216-225	220	10.43	.0257	119.2	5.15	5.4	4.9
226-235	230	11.31	.0260	121.2	5.30	5.5	5.1
236-245	240	12.18	.0263	123.2	5.43	5.7	5.2
246-255	250	13.06	.0266	125.3	5.57	5.8	5.4
256-265	260	13.93	.0268	127.3	5.70	5.9	5.5
266-275	270	14.80	.0271	129.3	5.82	6.1	5.6
276-285	280	15.68	.0274	131.4	5.95	6.2	5.7
286-295	290	16.55	.0277	133.4	6.06	6.3	5.8
296-305	300	17.43	.0279	135.4	6.18	6.4	6.0
306-315	310	18.39	.0282	137.5	6.29	6.5	6.1
316-325	320	19.17	.0285	139.5	6.40	6.6	6.2
326-335	330	30.05	.0288	141.6	6.50	6.7	6.3
336-345	340	20.92	.0290	143.6	6.60	6.8	6.4
346-355	350	21.80	.0293	145.6	6.70	6.9	6.5
356-365	360	22.67	.0296	147.7	6.80	7.0	6.6
366-375	370	23.54	.0299	149.7	6.89	7.1	6.7
376-385	380	24.42	.0301	151.7	6.98	7.2	6.8
386-395	390	25.29	.0304	153.8	7.07	7.3	6.9
396-405	400	26.17	.0307	155.8	7.16	7.4	6.9
406-415	410	27.04	.0310	157.8	7.24	7.5	7.0
416-425	420	27.91	.0312	159.9	7.33	7.6	7.1
426-435	430	28.79	.0315	161.9	7.41	7.6	7.2
436-445	440	29.66	.0317	163.7	7.49	7.7	7.3
446-455	450	30.54	.0318	164.9	7.61	7.8	7.4
456-465	460	31.41	.0319	166.0	7.73	8.0	7.5
466-475	470	32.28	.0319	167.1	7.84	8.1	7.6
476-485	480	33.16	.0320	168.3	7.95	8.2	7.7
486-495	490	43.03	.0320	169.4	8.06	8.3	7.8
496-505	500	34.90	.0321	170.5	8.17	8.4	7.9
506-515	510	35.78	.0322	171.7	8.28	8.5	8.0
516-525	520	36.65	.0322	172.8	8.39	8.6	8.2
526-535	530	37.53	.0323	173.9	8.49	8.7	8.3
536-545	540	38.40	.0323	175.1	8.60	8.8	8.4
546-555	550	39.27	.0324	176.2	8.70	9.0	8.5
556-565	560	40.15	.0325	177.3	8.80	9.1	8.6
566-575	570	41.02	.0325	178.5	8.90	9.2	8.7
576-585	580	41.90	.0326	179.6	9.00	9.3	8.8
586-595	590	42.77	.0327	180.8	9.10	9.4	8.9

FIGURE F78-9 — Continued

□ Loaded vehicle mass (kg)	Equivalent inertial mass (kg)	Force coefficients		Force at 65 km/h (nt)	70 to 60 km/h coastdown calibration times		
		A (nt)	C (nt/(km/h) ²)		Target time (sec)	Allowable tolerance	
						Longest time (sec)	Shortest time (sec)
596-605	600	43.64	.0327	181.9	9.19	9.5	8.9
606-615	610	44.52	.0328	183.0	9.29	9.5	9.0
616-625	620	45.39	.0328	184.2	9.38	9.6	9.1
626-635	630	46.27	.0329	185.3	9.47	9.7	9.2
636-645	640	47.14	.0330	186.4	9.56	9.8	9.3
646-655	650	48.01	.0330	187.6	9.65	9.9	9.4
656-665	660	48.89	.0331	188.7	9.74	10.0	9.5
666-675	670	49.76	.0332	189.8	9.83	10.1	9.6
676-685	680	50.64	.0332	191.0	9.92	10.2	9.7
686-695	690	51.91	.0333	192.1	10.0	10.3	9.8
696-705	700	52.38	.0333	193.2	10.09	10.4	9.8
706-715	710	53.26	.0334	194.4	10.17	10.4	9.9
716-725	720	54.13	.0335	195.5	10.26	10.5	10.0
726-735	730	55.01	.0335	196.6	10.34	10.6	10.1
736-745	740	55.88	.0336	197.8	10.42	10.7	10.2
746-755	750	56.75	.0336	198.9	10.50	10.8	10.2
756-760	760	57.63	.0337	200.1	10.58	10.9	10.3

(c) The dynamometer shall be adjusted to reproduce the specified road load as determined by the most recent calibration. Alternatively, the actual vehicle road load can be measured and duplicated:

(1) Make at least 5 replicate coastdowns in each direction from 70 to 60 km/h on a smooth, level, track under balanced wind conditions. The driver must have a mass of 80±10kg and be in the normal driving position. Record the coastdown time.

(2) Average the coastdown times. Adjust the dynamometer load so that the coastdown time is duplicated with the vehicle and driver on the dynamometer.

(3) Alternate procedures may be used if approved in advance by the Administrator.

§ 86.529-98 Road load force and inertia weight determination.

(a)(1) Road load as a function of speed is given by the following equation:

$$F = A + CV^2$$

(2) The values for coefficients A and C and the test inertia are given in Figure F98-9 of this section. Velocity V is in km/h and force (F) is in newtons. The forces given by the equation in paragraph (a)(1) of this section shall be simulated to the best ability of the equipment being used.

(b) The inertia given in Figure F98-9 shall be used. Motorcycles with loaded vehicle mass outside these limits shall be tested at an equivalent inertial mass and road load force specified by the Administrator. Figure F98-9 follows:

Figure F98-9

Loaded vehicle mass (kg)	Equivalent inertial mass (kg)	Force coefficients		Force at 65 km/h (nt)	70 to 60 km/h coastdown calibration times		
		A (nt)	C (nt/(km/h) ²)		Target time (sec)	Allowable tolerance	
						Longest time (sec)	Shortest time (sec)
95-105	100	0.0	.0224	94.8	2.95	3.1	2.8
106-115	110	0.82	.0227	96.8	3.18	3.3	3.0
116-125	120	1.70	.0230	98.8	3.39	3.6	3.2
126-135	130	2.57	.0233	100.9	3.60	3.8	3.4
136-145	140	3.44	.0235	102.9	3.80	4.0	3.6
146-155	150	4.32	.0238	104.9	3.99	4.2	3.8
156-165	160	5.19	.0241	107.0	4.10	4.4	4.0
166-175	170	6.06	.0244	109.0	4.36	4.6	4.2
176-185	180	6.94	.0246	111.0	4.53	4.7	4.3
186-195	190	7.81	.0249	113.1	4.69	4.9	4.5
196-205	200	8.69	.0252	115.1	4.85	5.1	4.6
206-215	210	9.56	.0255	117.1	5.00	5.2	4.8
216-225	220	10.43	.0257	119.2	5.15	5.4	4.9
226-235	230	11.31	.0260	121.2	5.30	5.5	5.1
236-245	240	12.18	.0263	123.2	5.43	5.7	5.2
246-255	250	13.06	.0266	125.3	5.57	5.8	5.4
256-265	260	13.93	.0268	127.3	5.70	5.9	5.5
266-275	270	14.80	.0271	129.3	5.82	6.1	5.6
276-285	280	15.68	.0274	131.4	5.95	6.2	5.7
286-295	290	16.55	.0277	133.4	6.06	6.3	5.8
296-305	300	17.43	.0279	135.4	6.18	6.4	6.0
306-315	310	18.30	.0282	137.5	6.29	6.5	6.1
316-325	320	19.17	.0285	139.5	6.40	6.6	6.2
326-335	330	20.05	.0288	141.6	6.50	6.7	6.3
336-345	340	20.92	.0290	143.6	6.60	6.8	6.4
346-355	350	21.80	.0293	145.6	6.70	6.9	6.5
356-365	360	22.67	.0296	147.7	6.80	7.0	6.6
366-375	370	23.54	.0299	149.7	6.89	7.1	6.7
376-385	380	24.42	.0301	151.7	6.98	7.2	6.8
386-395	390	25.29	.0304	153.8	7.07	7.3	6.9
396-405	400	26.17	.0307	155.8	7.16	7.4	6.9
406-415	410	27.04	.0310	157.8	7.24	7.5	7.0
416-425	420	27.91	.0312	159.9	7.33	7.6	7.1
426-435	430	28.79	.0315	161.9	7.41	7.6	7.2
436-445	440	29.66	.0317	163.7	7.49	7.7	7.3
446-455	450	30.54	.0318	164.9	7.61	7.8	7.4
456-465	460	31.41	.0319	166.0	7.73	8.0	7.5
466-475	470	32.28	.0319	67.1	7.84	8.1	7.6
476-485	480	33.16	.0320	168.3	7.95	8.2	7.7
486-495	490	34.03	.0320	169.4	8.06	8.3	7.8
496-505	500	34.90	.0321	170.5	8.17	8.4	7.9
506-515	510	35.78	.0322	171.7	8.28	8.5	8.0

516-525	520	36.65	.0322	172.8	8.39	8.6	8.2
526-535	530	37.53	.0323	173.9	8.49	8.7	8.3
536-545	540	38.40	.0323	175.1	8.60	8.8	8.4
546-555	550	39.27	.0324	176.2	8.70	9.0	8.5
556-565	560	40.15	.0325	177.3	8.80	9.1	8.6
566-575	570	41.02	.0325	178.5	8.90	9.2	8.7

Figure F98-9 — Continued

576-585	580	41.90	.0326	179.6	9.00	9.3	8.8
586-595	590	42.77	.0327	180.8	9.10	9.4	8.9
596-605	600	43.64	.0327	181.9	9.19	9.5	8.9
606-615	610	44.52	.0328	183.0	9.29	9.5	9.0
616-625	620	45.39	.0328	184.2	9.38	9.6	9.1
626-635	630	46.27	.0329	185.3	9.47	9.7	9.2
636-645	640	47.14	.0330	186.4	9.56	9.8	9.3
646-655	650	48.01	.0330	187.6	9.65	9.9	9.4
656-665	660	48.89	.0331	188.7	9.74	10.0	9.5
666-675	670	49.76	.0332	189.8	9.83	10.1	9.6
676-685	680	50.64	.0332	191.0	9.92	10.2	9.7
686-695	690	51.51	.0333	192.1	10.01	10.3	9.8
696-705	700	52.38	.0333	193.2	10.09	10.4	9.8
706-715	710	53.26	.0334	194.4	10.17	10.4	9.9
716-725	720	54.13	.0335	195.5	10.26	10.5	10.0
726-735	730	55.01	.0335	196.6	10.34	10.6	10.1
736-745	740	55.88	.0336	197.8	10.42	10.7	10.2
746-755	750	56.75	.0336	198.9	10.50	10.8	10.2
756-765	760	57.63	.0337	200.1	10.58	10.9	10.3
766-775	770	58.50	.0338	201.2	10.66	10.9	10.3
776-785	780	59.38	.0338	203.3	10.74	11.0	10.4
786-795	790	60.25	.0339	204.5	10.82	11.1	10.5
796-805	800	61.12	.0339	205.6	10.91	11.2	10.6
806-815	810	62.00	.0340	206.7	10.99	11.3	10.7
816-825	820	62.87	.0341	207.9	11.07	11.4	10.8
826-835	830	63.75	.0341	209.0	11.15	11.5	10.8
836-845	840	64.62	.0342	210.1	11.24	11.5	10.9
846-855	850	65.49	.0343	211.3	11.32	11.6	11.0
856-865	860	66.37	.0343	212.4	11.40	11.7	11.1
866-873	870	67.24	.0344	213.5	11.48	11.8	11.2

(c) The dynamometer shall be adjusted to reproduce the specified road load as determined by the most recent calibration. Alternatively, the actual vehicle road load can be measured and duplicated:

(1) Make at least 5 replicate coastdowns in each direction from 70 to 60 km/h on a smooth, level track under balanced wind conditions. The driver must have a mass of 80±10 kg and be in the normal driving position. Record the coastdown time.

(2) Average the coastdown times. Adjust the dynamometer load so that the coastdown time is duplicated with the vehicle and driver on the dynamometer.

(3) Alternate procedures may be used if approved in advance by the Administrator.

[63 FR 11849, Mar. 11, 1998]

§ 86.530-78 Test sequence, general requirements.

(a) Ambient temperature levels encountered by the test vehicle throughout the test sequence shall not be less than 20 °C (68 °F) nor more than 30 °C (86 °F). The vehicle shall be approximately level during the emission test to prevent abnormal fuel distribution.

(b) [Reserved]

§ 86.531-78 Vehicle preparation.

(a) The manufacturer shall provide additional fittings and adapters, as required by the Administrator * * *, such as * * * to accommodate a fuel drain at the lowest point possible in the tank(s) as installed on the vehicle and to provide for exhaust sample collection.

(b) [Reserved]

§ 86.532-78 Vehicle preconditioning.

(a) The vehicle shall be moved to the test area and the following operations performed:

(1) The fuel tank(s) shall be drained through the provided fuel tank(s) drain(s) and charged with the specified test fuel, § 86.513, to half the tank(s) capacity.

(2) The vehicle shall be placed, either by being driven or pushed, on a dynamometer and operated through one Urban Dynamometer Driving Schedule test procedure (see § 86.515 and appendix I). The vehicle need not be cold, and may be used to set dynamometer horsepower.

(b) Within five (5) minutes of completion of preconditioning, the vehicle shall be removed from the dynamometer and may be driven or pushed to the soak area to be parked. The vehicle shall be stored for not less than the following times prior to the cold start exhaust test.

	Hours
Class	6
Class II.....	8
Class III.....	12

In no case shall the vehicle be stored for more than 36 hours prior to the cold start exhaust test.

§ 86.535-90 Dynamometer procedure.

(a) The dynamometer run consists of two tests, a "cold" start test and a "hot" start test following the "cold" start by 10 minutes. Engine startup (with all accessories turned off), operation over the driving schedule, and engine shutdown make a complete cold start test. Engine startup and operation over the first 505 seconds of the driving schedule complete the hot start test. The exhaust emissions are diluted with ambient air and a continuously proportional sample is collected for analysis during each phase. The composite samples collected in bags are analyzed for hydrocarbons, carbon monoxide, carbon dioxide, and, optionally, for oxides of nitrogen. A parallel sample of the dilution air is similarly analyzed for hydrocarbon, carbon monoxide, carbon dioxide, and, optionally, for oxides of nitrogen. Methanol and formaldehyde samples (exhaust and dilution air) are collected and analyzed for methanol-fueled vehicles (a single dilution air formaldehyde sample covering the total time of the test may be collected in place of individual test phases).

(b) [Reserved]

(c) The vehicle speed, as measured from the dynamometer roll, shall be used. A speed vs. time recording, as evidence of dynamometer test validity, shall be supplied on request of the Administrator.

(d) Practice runs over the prescribed driving schedule may be performed at test points, provided an emission sample is not taken, for the purpose of finding the minimum throttle action to maintain the proper speed-time relationship, or to permit sampling system adjustments.

(e) The drive wheel tires must be inflated to the manufacturer's recommended pressure, ±15 kPa (±2.2 psi). The drive wheel tire pressure shall be reported with the test results.

(f) If the dynamometer has not been operated during the two-hour period immediately preceding the test, it shall be warmed up for 15 minutes by operating at 50 km/h (31 mph) using a nontest vehicle, or as recommended by the dynamometer manufacturer.

(g) If the dynamometer horsepower must be adjusted manually, it shall be set within one

hour prior to the exhaust emissions test phase. The test vehicle shall not be used to make this adjustment. Dynamometers using automatic control of preselectable power settings may be set anytime prior to the beginning of the emissions test.

(h) The driving distance, as measured by counting the number of dynamometer roll revolutions, shall be determined for the transient cold start, stabilized cold start, and transient hot start phases of the test.

[54 FR 14551, Apr. 11, 1989]

§86.536-78 Engine starting and restarting.

(a)(1) The engine shall be started according to the manufacturer's recommended starting procedures. The initial 20 second idle period shall begin when the engine starts.

(2) *Choke operation.* (i) Vehicles equipped with automatic chokes shall be operated according to the instructions in the manufacturer's operating instructions or owner's manual including choke setting and "kick-down" from cold fast idle. The transmission shall be placed in gear 15 seconds after the engine is started. If necessary, braking may be employed to keep the drive wheels from turning.

(ii) Vehicles equipped with manual chokes shall be operated according to the manufacturer's operating instructions or owner's manual. Where times are provided in the instructions, the Administrator may specify the specific point for operation, within 15 seconds of the recommended time.

(3) The operator may use the choke, throttle etc. where necessary to keep the engine running.

(4) If the manufacturer's operating instructions or owner's manual do not specify a warm engine starting procedure, the engine (automatic and manual choke engines) shall be started by opening the throttle about half way and cranking the engine until it starts.

(b) [Reserved]

(c) If, during the cold start, the vehicle does not start after 10 seconds of cranking, or ten cycles of the manual starting mechanism,

cranking shall cease and the reason for failure to start determined. The revolution counter on the constant volume sampler shall be turned off and the sample solenoid valves placed in the "standby" position during this diagnostic period. In addition, either the CVS blower shall be turned off or the exhaust tube disconnected from the tailpipe during the diagnostic period.

(1) If failure to start is an operational error, the vehicle shall be rescheduled for testing from a cold start. If failure to start is caused by vehicle malfunction, corrective action (following the unscheduled maintenance provisions) of less than 30 minutes duration may be taken and the test continued. The sampling system shall be reactivated at the same time cranking is started. When the engine starts, the driving schedule timing sequence shall begin. If failure to start is caused by vehicle malfunction and the vehicle cannot be started, the test shall be voided, the vehicle removed from the dynamometer, corrective action taken (following the unscheduled maintenance provisions), and the vehicle rescheduled for test. The reason for the malfunction (if determined) and the corrective action taken shall be reported.

(2) If the vehicle does not start during the hot start after ten seconds of cranking, or ten cycles of the manual starting mechanism, cranking shall cease, the test shall be voided, the vehicle removed from the dynamometer, corrective action taken in accordance with § 86.428 or § 86.429, and the vehicle rescheduled for test. The reason for the malfunction (if determined) and the corrective action taken shall be reported.

(d) If the engine "false starts", the operator shall repeat the recommended starting procedure (such as resetting the choke, etc.)

(e) *Stalling.* (1) If the engine stalls during an idle period, the engine shall be restarted immediately and the test continued. If the engine cannot be started soon enough to allow the vehicle to follow the next acceleration as prescribed, the driving schedule indicator shall be stopped. When the vehicle restarts, the driving schedule indicator shall be reactivated.

(2) If the engine stalls during some operating mode other than idle, the driving schedule indicator shall be stopped, the vehicle shall

then be restarted and accelerated to the speed required at that point in the driving schedule and the test continued. During acceleration to this point, shifting shall be performed in accordance with § 86.528.

(3) If the vehicle will not restart within one minute, the test shall be voided, the vehicle removed from the dynamometer, corrective action taken, and the vehicle rescheduled for test. The reason for the malfunction (if determined) and the corrective action taken shall be reported.

§ 86.537-90 Dynamometer test runs.

(a) The vehicle shall be allowed to stand with the engine turned off (see § 86.532 for required time). The vehicle shall be stored prior to the emission test in such a manner that precipitation (*e.g.*, rain or dew) does not occur on the vehicle. The complete dynamometer test consists of a cold start drive of 12.0 km (7.5 mi), (10.9 km (6.8 mi) for Class I motorcycles) and simulates a hot start drive of 12.0 km (7.5 mi), (10.9 km (6.8 mi) for Class I motorcycles). The vehicle is allowed to stand on the dynamometer during the 10-minute period between the cold and hot start tests. The cold start is divided into two periods. The first period, representing the cold start "transient" phase, terminates at the end of the deceleration which is scheduled to occur at 505 seconds of the driving schedule. The second period, representing the "stabilized" phase, consists of the remainder of the driving schedule including engine shutdown. The hot start test similarly consists of two periods. The period, representing the hot start "transient" phase, terminates at the same point in the driving schedule at the first point of the cold start test. The second period of the hot start test, "stabilized" phase, is assumed to be identical to the second period of the cold start test. Therefore, the hot start test terminates after the first period (505 seconds) is run.

(b) The following steps shall be taken for each test:

- (1) Place drive wheel of vehicle on dynamometer without starting engine.
- (2) Activate vehicle cooling fan.
- (3) For all vehicles, with the sample selector valves in the "standby" position connect evacuated sample collection bags to the dilute

exhaust and dilution air sample collection systems.

(4) For methanol-fueled vehicles, with the sample selector valves in the "standby" position, insert fresh sample collection impingers into the methanol sample collection system, fresh impingers or a fresh cartridge into the formaldehyde sample collection system and fresh impingers (or a single cartridge for formaldehyde) into the dilution air sample collection systems for methanol and formaldehyde (background measurements of methanol and formaldehyde may be omitted and concentrations assumed to be zero for calculations in § 86.544).

(5) Start the CVS (if not already on), the sample pumps and the temperature recorder. (The heat exchanger of the constant volume sampler, if used, methanol-fueled vehicle hydrocarbon analyzer and sample lines should be preheated to their respective operating temperatures before the test begins.)

(6) Adjust the sample flow rates to the desired flow rate and set the gas flow measuring devices to zero.

(i) For gaseous bag samples (except hydrocarbon samples), the minimum flow rate is 0.17 cfm (0.08 l/s).

(ii) For hydrocarbon samples, the minimum FID (or HFID in the case of methanol-fueled vehicles) flow rate is 0.066 cfm (0.031 l/s).

(iii) For methanol samples, the flow rates shall be set such that the system meets the design criteria of §86.509. For samples in which the concentration in the primary impinger exceeds 0.5 mg/l, it is recommended that the mass of methanol collected in the secondary impinger not exceed ten percent of the total mass collected. For samples in which the concentration in the primary impinger does not exceed 0.5 mg/l, secondary impingers do not need to be analyzed.

(iv) For formaldehyde samples, the flow rates shall be set such that the system meets the design criteria of §86.509. For impinger samples in which the concentration of formaldehyde in the primary impinger exceeds 0.1 mg/l, it is recommended that the mass of formaldehyde collected in the secondary impinger not exceed ten

percent of the total mass collected. For samples in which the concentration in the primary impinger does not exceed 0.1 mg/l, secondary impingers do not need to be analyzed.

(7) Attach the flexible exhaust tube to the vehicle tailpipe(s).

(8) Start the gas flow measuring device, position the sample selector valves to direct the sample flow into the "transient" exhaust sample bag, the "transient" methanol exhaust sample, the "transient" formaldehyde exhaust sample, the "transient" dilution air sample bag, the "transient" methanol dilution air sample and the "transient" formaldehyde dilution air sample, turn the key on, and start cranking the engine.

(9) Fifteen seconds after the engine starts, place the transmission in gear.

(10) Twenty seconds after the engine starts, begin the initial vehicle acceleration of the driving schedule.

(11) Operate the vehicle according to the Urban Dynamometer Driving Schedule (§ 86.515).

(12) At the end of the deceleration which is scheduled to occur at 505 seconds, simultaneously switch the sample flows from the "transient" bags and samples to "stabilized" bags and samples, switch off gas flow measuring device No. 1 and, start gas flow measuring device No. 2. Before the acceleration which is scheduled to occur at 510 seconds, record the measured roll or shaft revolutions and reset the counter or switch to a second counter. As soon as possible, transfer the "stabilized" exhaust and dilution air samples to the analytical system and process the samples according to §86.540, obtaining a stabilized reading of the exhaust bag sample on all analyzers within 20 minutes of the end of the sample collection phase of the test. Obtain methanol and formaldehyde sample analyses, if applicable, within 24 hours of the end of the sample period. (If it is not possible to perform analysis on the methanol and formaldehyde samples within 24 hours, the samples should be stored in a dark cold (4-10 °C) environment until analysis. The samples should be analyzed within fourteen days.)

(13) Turn the engine off 2 seconds after the end of the last deceleration (at 1,369 seconds).

(14) Five seconds after the engine stops running, simultaneously turn off gas flow measuring device No. 2 and position the sample selector valves to the "standby" position (and open the valves isolating particulate filter No. 1, if applicable). Record the measured roll or shaft revolutions (both gas meter or flow measurement instrumentation readings) and re-set the counter. As soon as possible, transfer the "stabilized" exhaust and dilution air samples to the analytical system and process the samples according to § 86.540, obtaining a stabilized reading of the exhaust bag sample on all analyzers within 20 minutes of the end of the sample collection phase of the test. Obtain methanol and formaldehyde sample analyses, if applicable, within 24 hours of the end of the sample period. (If it is not possible to perform analysis on the methanol and formaldehyde samples within 24 hours, the samples should be stored in a dark cold (4-10° C) environment until analysis. The samples should be analyzed within fourteen days.)

(15) Immediately after the end of the sample period, turn off the cooling fan.

(16) Turn off the CVS or disconnect the exhaust tube from the tailpipe(s) of the vehicle.

(17) Repeat the steps in paragraph (b) (2) through (11) of this section for the hot start test, except only two evacuated sample bags, two methanol sample impingers, and two formaldehyde sample impingers are required. The step in paragraph (b)(8) of this section shall begin between 9 and 11 minutes after the end of the sample period for the cold start test.

(18) At the end of the deceleration which is scheduled to occur at 505 seconds, simultaneously turn off gas flow measuring device No. 1 and position the sample selector valve to the "standby" position. (Engine shutdown is not part of the hot start test sample period.) Record the measured roll or shaft revolutions.

(19) As soon as possible, transfer the hot start "transient" exhaust and dilution air bag samples to the analytical system and process the samples according to §86.540 obtaining a stabi-

lized reading of the bag exhaust sample on all analyzers within 20 minutes of the end of the sample collection phase of the test. Obtain methanol and formaldehyde sample analyses, if applicable, within 24 hours of the end of the sample period (if it is not possible to perform analysis on the methanol and formaldehyde samples within 24 hours, the samples should be stored in a dark, cold (~ 0 °C) environment until analysis).

(20) Disconnect the exhaust tube from the vehicle tailpipe(s) and remove the vehicle from dynamometer.

(21) The CVS or CFV may be turned off, if desired.

(22) Continuous monitoring of exhaust emissions will not normally be allowed. Specific written approval must be obtained from the Administrator for continuous monitoring of exhaust emissions.

[54 FR 14551, Apr. 11, 1989, as amended at 60 FR 34357, June 30, 1995]

§ 86.540-90 Exhaust sample analysis.

The following sequence of operations shall be performed in conjunction with each series of measurements:

(a) For CO, CO₂, gasoline-fueled, natural gas-fueled, liquefied petroleum gas-fueled and methanol-fueled motorcycle HC and, if appropriate, NO_x:

(1) Zero the analyzers and obtain a stable zero reading. Recheck after tests.

(2) Introduce span gases and set instrument gains. In order to avoid errors, span and calibrate at the same flow rates used to analyze the test sample. Span gases should have concentrations equal to 75 to 100 percent of full scale. If gain has shifted significantly on the analyzers, check the calibrations. Show actual concentrations on chart.

(3) Check zeros; repeat the procedure in paragraphs (a) (1) and (2) of this section if required.

(4) Check flow rates and pressures.

(5) Measure HC, CO, CO₂, and, if appropriate, NO_x, concentrations of samples.

(6) Check zero and span points. If difference is greater than 2 percent of full scale, repeat the procedure in paragraphs (a) (1) through (5) of this section.

(b) For CH₃OH (methanol-fueled vehicles), introduce test samples into the gas chromatograph and measure the concentration. This concentration is C_{MS} in the calculations.

(c) For HCHO (methanol-fueled vehicles), introduce test samples into the high pressure liquid chromatograph and measure the concentration of formaldehyde as a dinitrophenylhydrazine derivative in acetonitrile. This concentration is C_{FS} in the calculations.

[54 FR 14552, Apr. 11, 1989, as amended at 59 FR 48515, Sept. 21, 1994; 60 FR 34357, June 30, 1995]

§ 86.542-90 Records required.

The following information shall be recorded with respect to each test:

(a) Test number.

(b) System or device tested (brief description).

(c) Date and time of day for each part of the test schedule.

(d) Instrument operator.

(e) Driver or operator.

(f) *Vehicle*: Make, Vehicle identification number, Model year, Transmission type, Odometer reading at initiation of preconditioning, Engine displacement, Engine family, Emission control system, Recommended idle RPM, Nominal fuel tank capacity, Inertial loading, Actual curb mass recorded at 0 kilometers, and Drive wheel tire pressure.

(g) *Dynamometer serial number*: As an alternative to recording the dynamometer serial number, a reference to a vehicle test cell number may be used, with the advance approval of the Administrator, provided the test cell records show the pertinent instrument information.

(h) All pertinent instrument information such as tuning-gain-serial number-detector number-range. As an alternative, a reference to a vehicle test cell number may be used, with the advance approval of the Administrator, provided test cell calibration records show the pertinent instrument information.

(i) Recorder Charts: Identify zero, span, exhaust gas, and dilution air sample traces.

(j) Test cell barometric pressure, ambient temperature and humidity.

Note: A central laboratory barometer may be used; *Provided*, that individual test cell barometric pressures are shown to be within ± 0.1 percent of the barometric pressure at the central barometer location.

(k) [Reserved]

(l) Pressure of the mixture of exhaust and dilution air entering the CVS metering device, the pressure increase across the device, and the temperature at the inlet. The temperature may be recorded continuously or digitally to determine temperature variations.

(m) The number of revolutions of the positive displacement pump accumulated during each test phase while exhaust samples are being collected. The number of standard cubic meters metered by a critical flow venturi during each test phase would be the equivalent record for a CFV-CVS.

(n) The humidity of the dilution air.

Note: If conditioning columns are not used (see §§ 86.522 and 86.544) this measurement can be deleted. If the conditioning columns are used and the dilution air is taken from the test cell, the ambient humidity can be used for this measurement.

(o) The driving distance for each of the three phases of test, calculated from the measured roll or shaft revolutions.

(p) Additional required records for methanol-fueled vehicles:

(1) Specification of the methanol fuel, or fuel mixtures, used during testing.

(2) Volume of sample passed through the methanol sampling system and the volume of deionized water in each impinger.

(3) The methanol calibration information from the GC standards.

(4) The concentration of the GC analyses of the test samples (methanol).

(5) Volume of sample passed through the formaldehyde sampling system.

(6) The formaldehyde calibration information from the HPLC standards.

(7) The concentration of the HPLC analysis of the test sample (formaldehyde).

(q) *Additional required records for natural gas-fueled vehicles.* Composition, including all carbon containing compounds; e.g. CO₂, of the natural gas-fuel used during the test. C₁ and C₂ compounds shall be individually reported. C₃ and heavier hydrocarbons and C₆ and heavier compounds may be reported as a group.

(r) *Additional required records for liquefied petroleum gas-fueled vehicles.* Composition of the liquefied petroleum gas-fuel used during the test. Each hydrocarbon compound present, through C₄ compounds, shall be individually reported. C₅ and heavier hydrocarbons may be reported as a group.

[54 FR 14553, Apr. 11, 1989, as amended at 59 FR 48515, Sept. 21, 1994; 60 FR 34357, June 30, 1995]

§ 86.544-90 Calculations; exhaust emissions.

The final reported test results, with oxides of nitrogen being optional, shall be computed by use of the following formula: (The results of all emission tests shall be rounded, using the "Rounding-Off Method" specified in ASTM E 29-67, to the number of places to the right of the decimal point indicated by expressing the applicable standard to three significant figures.)

$$(a) Y_{wm} = 0.43 \left(\frac{Y_{ct} + Y_s}{D_{ct} + D_s} \right) + 0.57 \left(\frac{Y_{ht} + Y_s}{D_{ht} + D_s} \right)$$

Where:

(1) Y_{wm} = Weighted mass emissions of CO₂ or of each pollutant (*i.e.*, HC, CO, or NO_x) in grams per vehicle kilometer and if appropriate, the weighted carbon mass equivalent of total hydrocarbon equivalent, in grams per vehicle kilometer.

(2) Y_{ct} = Mass emissions as calculated from the "transient" phase of the cold-start test, in grams per test phase.

(3) Y_{ht} = Mass emissions as calculated from the "transient" phase of the hot-start test, in grams per test phase.

(4) Y_s = Mass emissions as calculated from the "stabilized" phase of the cold-start test, in grams per test phase.

(5) D_{ct} = The measured driving distance from the "transient" phase of the cold-start test, in kilometers.

(6) D_{ht} = The measured driving distance from the "transient" phase of the hot-start test, in kilometers.

(7) D_s = The measured driving distance from the "stabilized" phase of the cold-start test, in kilometers.

(b) The mass of each pollutant for each phase of both the cold-start test and the hot-start test is determined from the following:

(1) Hydrocarbon mass:

$$HC_{mass} = V_{mix} \times \text{Density}_{HC} \times (HC_{conc} / 1,000,000)$$

(2) Oxides of nitrogen mass:

$$NOx_{mass} = V_{mix} \times \text{Density}_{NO2} \times K_H \times (NOx_{conc} / 1,000,000)$$

(3) Carbon monoxide mass:

$$CO_{mass} = V_{mix} \times \text{Density}_{CO} \times (CO_{conc} / 1,000,000)$$

(4) Carbon dioxide mass:

$$CO_{2mass} = V_{mix} \times \text{Density}_{CO2} \times (CO_{2conc} / 100)$$

(5) Methanol mass:

$$CH_3OH_{mass} = V_{mix} \times \text{Density}_{CH_3OH} \times (CH_3OH_{conc} / 1,000,000)$$

(6) Formaldehyde mass:

$$HCHO_{mass} = V_{mix} \times \text{Density}_{HCHO} \times (HCHO_{conc} / 1,000,000)$$

(7) Total hydrocarbon equivalent:

$$(i) THCE = HC_{mass} + 13.8756/32.042 \times (CH_3OH)_{mass} + 13.8756/30.0262 \times (HCHO)_{mass}$$

(c) Meaning of symbols:

(1)(i) HC_{mass} = Hydrocarbon emissions, in grams per test phase.

(ii) Density_{HC} = Density of HC in exhaust gas.

(A) For *gasoline-fuel*; Density_{HC} = 576.8 g/m³-carbon atom (16.33 g/ft³-carbon atom), assuming an average carbon to hydrogen ratio of 1:1.85, at 20 °C (68 °F) and 101.3 kPa (760 mm Hg) pressure.

(B) For *natural gas and liquefied petroleum gas-fuel*; Density_{HC} =

41.57(12.011+H/C(1.008)) g/m³-carbon atom (1.1771(12.011+H/C(1.008)) g/ft³-carbon atom) where H/C is the hydrogen to carbon ratio of the hydrocarbon components of test fuel, at 20 °C (68 °F) and 101.3 kPa (760mm Hg) pressure.

(iii)(A) HC_{conc} = Hydrocarbon concentration of the dilute exhaust sample corrected for background, in ppm carbon equivalent, *i.e.*, equivalent propane x 3.

$$(B) HC_{conc} = HC_e - HC_d(1 - (1/DF))$$

Where:

(iv)(A) HC_e = Hydrocarbon concentrations of the dilute exhaust sample as measured, in ppm carbon equivalent (propane ppm x 3).

$$(B) HC_e = FIDHC_e - (r)C_{CH_3OHe}$$

(v) FID HC_e = Concentration of hydrocarbon (plus methanol if methanol-fueled motorcycle is tested) in dilute exhaust as measured by the FID ppm carbon equivalent.

(vi) r = FID response to methanol.

(vii) C_{CH_3OHe} = Concentration of methanol in dilute exhaust as determined from the dilute exhaust methanol sample, ppm carbon.

(viii)(A) HC_d = Hydrocarbon concentration of the dilution air as measured, ppm carbon equivalent.

$$(B) HC_d = FID HC_d - (r)C_{CH_3OHd}$$

(ix) FID HC_d = Concentration of hydrocarbon (plus methanol if methanol-fueled motorcycle is tested) in dilution air as measured by the FID, ppm carbon equivalent.

(x) C_{CH_3OHd} = Concentration of methanol in dilution air as determined from dilution air methanol sample, ppm carbon.

(2)(i) NOx_{mass} = Oxides of nitrogen emissions, grams per test phase.

(ii) Density_{NO2} = Density of oxides of nitrogen in the exhaust gas, assuming they are in the form of nitrogen dioxide, 1913 g/m³ (54.16 g/ft³), at 20 °C (68 °F) and 101.3 kPa (760 mm Hg) pressure.

(iii)(A) NOx_{conc} = Oxides of nitrogen concentration of the dilute exhaust sample corrected for background, ppm.

$$(B) NOx_{conc} = NOx_e - NOx_d(1 - (1/DF))$$

Where:

(iv) NO_x_e = Oxides of nitrogen concentration of the dilute exhaust sample as measured, ppm.

(v) NO_x_d = Oxides of nitrogen concentration of the dilution air as measured, ppm.

(3)(i) CO_{mass} = Carbon monoxide emissions, in grams per test phase.

(ii) Density_{CO} = Density of carbon monoxide, 1164 g/m³ (32.97 g/ft³), at 20 °C (68 °F) and 101.3 kPa (760 mm Hg) pressure.

(iii)(A) CO_{conc} = Carbon monoxide concentration of the dilute exhaust sample corrected for background, water vapor, and CO₂ extraction, ppm.

$$(B) CO_{conc} = CO_e - CO_d(1 - (1/DF))$$

Where:

(iv)(A) CO_e = Carbon monoxide concentration of the dilute exhaust sample volume corrected for water vapor and carbon dioxide extraction, in ppm.

(B) CO_e = (1 - 0.01925CO_{2e} - 0.000323R)CO_{em} for gasoline-fueled vehicles with hydrogen to carbon ratio of 1.85:1

(C) CO_e = [1 - (0.01+0.005HCR) CO_{2e} - 0.000323R]CO_{em} for methanol-fueled, natural gas-fueled or liquefied petroleum gas-fueled motorcycles, where HCR is hydrogen to carbon ratio as measured for the fuel used.

(v) CO_{em} = Carbon monoxide concentration of the dilute exhaust sample as measured, ppm

(vi) CO_{2e} = Carbon dioxide concentration of the dilute exhaust sample, pct.

(vii) R = Relative humidity of the dilution air, pct (see §86.542(n)).

(viii)(A) CO_d = Carbon monoxide concentration of the dilution air corrected for water vapor extraction, ppm.

$$(B) CO_d = (1 - 0.000323R)CO_{dm}$$

Where:

(ix) CO_{dm} = Carbon monoxide concentration of the dilution air sample as measured, ppm.

Note: If a CO instrument which meets the criteria specified in §. 86.511 is used and the conditioning column has been deleted, CO_{em} can be substituted directly for CO_e and CO_{dm} must be substituted directly for CO_d.

(4)(i) CO_{2mass} = Carbon dioxide emissions, grams per test phase.

(ii) Density_{CO2} = Density of carbon dioxide, 1830 g/m³ (51.81 g/ft³), at 20 °C (68 °F) and 101.3 kPa (760 mm Hg) pressure.

(iii)(A) CO_{2conc} = carbon dioxide concentration of the dilute exhaust sample corrected for background, in percent.

$$(B) CO_{2conc} = CO_{2e} - CO_{2d}(1 - 1/DF)$$

Where:

(iv) CO_{2d} = Carbon dioxide concentration of the dilution air as measured, in percent.

(5)(i) CH₃OH_{mass} = Methanol emissions corrected for background, grams per test phase.

(ii) Density_{CH3OH} = Density of methanol is 1332 g/m³ (37.71 g/ft³), at 20 °C (68 °F) and 101.3 kPa (760 mm Hg) pressure.

(iii)(A) CH₃OH_{conc} = Methanol concentration of the dilute exhaust corrected for background, ppm.

$$(B) CH_3OH_{conc} = C_{CH_3OH_e} - C_{CH_3OH_d}(1 - (1/DF))$$

Where:

(iv)(A) C_{CH3OH_e} = Methanol concentration in the dilute exhaust, ppm.

(B)

$$C_{CH_3OH_e} = \frac{3.813 \times 10^{-2} \times T_{EM} [(C_{S1} \times AV_{S1}) + (C_{S2} \times AV_{S2})]}{P_B \times V_{EM}}$$

(v)(A) C_{CH3OH_d} = Methanol concentration in the dilution air, ppm.

(B)

$$C_{\text{CH}_3\text{OHd}} = \frac{3.813 \times 10^{-2} \times T_{\text{DM}} [(C_{\text{D1}} \times AV_{\text{D1}}) + (C_{\text{D2}} \times AV_{\text{D2}})]}{P_{\text{B}} \times V_{\text{DM}}}$$

(vi) T_{EM} = Temperature of methanol sample withdrawn from dilute exhaust, °R.

(vii) T_{DM} = Temperature of methanol sample withdrawn from dilution air, °R.

(viii) P_{B} = Barometric pressure during test, mm Hg.

(ix) V_{EM} = Volume of methanol sample withdrawn from dilute exhaust, ft³.

(x) V_{DM} = Volume of methanol sample withdrawn from dilution air, ft³.

(xi) C_{s} = GC concentration of sample drawn from dilute exhaust, µg/ml.

(xii) C_{D} = GC concentration of sample drawn from dilution air, µg/ml.

(xiii) AV_{s} = Volume of absorbing reagent (de-ionized water) in impinger through which methanol sample from dilute exhaust is drawn, ml.

(xiv) AV_{D} = Volume of absorbing reagent (de-ionized water) in impinger through which methanol sample from dilution air is drawn, ml.

(xv) 1 = first impinger.

(xvi) 2 = second impinger.

(6)(i) $\text{HCHO}_{\text{mass}}$ = Formaldehyde emissions corrected for background, grams per test phase.

(ii) $\text{Density}_{\text{HCHO}}$ = Density of formaldehyde is 1249 g/m³ (35.36 g/ft³), at 20 °C (68 °F) and 101.3 kPa (760 mm Hg) pressure.

(iii)(A) $\text{HCHO}_{\text{conc}}$ = Formaldehyde concentration of the dilute exhaust corrected for background, ppm.

(B) $\text{HCHO}_{\text{conc}} = C_{\text{HCHOe}} - C_{\text{HCHOd}}(1 - (1/\text{DF}))$

Where:

(iv)(A) C_{HCHOe} = Formaldehyde concentration in dilute exhaust, ppm.

(B)

$$C_{\text{HCHOe}} = \frac{4.069 \times 10^{-2} \times C_{\text{FDE}} \times V_{\text{AE}} \times Q \times T_{\text{EF}}}{V_{\text{SE}} \times P_{\text{B}}}$$

(v)(A) C_{HCHOd} = Formaldehyde concentration in dilution air, ppm.

(B)

$$C_{\text{HCHOd}} = \frac{4.069 \times 10^{-2} \times C_{\text{FDA}} \times V_{\text{AA}} \times Q \times T_{\text{DF}}}{V_{\text{SA}} \times P_{\text{B}}}$$

(vi) C_{FDE} = Concentration of DNPH derivative of formaldehyde from dilute exhaust sample in sampling solution, µg/ml.

(vii) V_{AE} = Volume of sampling solution for dilute exhaust formaldehyde sample, ml.

(viii)(A) Q = Ratio of molecular weights of formaldehyde to its DNPH derivative.

(B) $Q = 0.1429$

(ix) T_{EF} = Temperature of formaldehyde sample withdrawn from dilute exhaust, °R.

(x) V_{SE} = Volume of formaldehyde sample withdrawn from dilute exhaust, ft³.

(xi) P_{B} = Barometric pressure during test, mm Hg.

(xii) C_{FDA} = Concentration of DNPH derivative of formaldehyde from dilution air sample in sampling solution, µg/ml.

(xiii) V_{AA} = Volume of sampling solution for dilution air formaldehyde sample, ml.

(xiv) T_{DF} = Temperature of formaldehyde sample withdrawn from dilution air, °R.

(xv) V_{SA} = Volume of formaldehyde sample withdrawn from dilution air, ft³.

(7)(i) $DF = 13.4/[CO_{2e} + (HC_e + CO_e)10^{-4}]$ for gasoline-fueled vehicles.

(ii) For methanol-fueled, natural gas-fueled or liquefied petroleum gas-fueled motorcycles, where fuel composition is $C_xH_yO_z$ as measured, or calculated, for the fuel used (for natural gas and liquefied petroleum gas-fuel, $Z=0$):

$$DF = \frac{(100) \frac{x}{(x + y/2 + 3.76)(x + y/2 - z/2)}}{CO_{2e} + (HC_e + CO_e + CH_3OH_e = HCHO_e) \times 10^{-4}}$$

(iii)(A) V_{mix} = Total dilute exhaust volume in cubic meters per test phase corrected to standard conditions (293 °K (528 °R) and 101.3 kPa (760 mm Hg)).

(B)

$$V_{\text{mix}} = \frac{V_o \times N \times (P_B - P_i) \times 293}{101.3 \times T_p}$$

Where:

(iv) V_o = Volume of gas pumped by the positive displacement pump, in cubic meters per revolution. This volume is dependent on the pressure differential across the positive displacement pump. (See calibration techniques in § 86.519.)

(v) N = Number of revolutions of the positive displacement pump during the test phase while samples are being collected.

(vi) P_B = Barometric pressure, kPa.

(vii) P_i = Pressure depression below atmospheric measured at the inlet to the positive displacement pump, kPa.

(viii) T_p = Average temperature of dilute exhaust entering positive displacement pump during test while samples are being collected, ° K.

(ix)(A) K_h = Humidity correction factor.

(B) $K_h = 1/[1 - 0.0329(H - 10.71)]$

Where:

(x)(A) H = Absolute humidity in grams of water per kilogram of dry air.

(B) $H = [(6.211)R_a \times P_d]/[P_B - (P_d \times R_a/100)]$

(xi) R_a = Relative humidity of the ambient air, pct.

(xii) P_d = Saturated vapor pressure, in kPa at the ambient dry bulb temperature.

(xiii) P_B = Barometric pressure, kPa.

(d) Sample calculation of mass emission values for gasoline-fueled vehicles with engine displacements equal to or greater than 170 cc (10.4 cu. in.):

(1) For the "transient" phase of the cold-start test, assume $V_o = 0.0077934 \text{ m}^3$ per rev; $N = 12,115$; $R = 20.5$ pct; $R_a = 20.5$ pct; $P_B = 99.05$ kPa; $P_d = 3.382$ kPa; $P_i = 9.851$ kPa; $T_p = 309.8$ °K; $HC_e = 249.75$ ppm carbon equivalent; $NO_{x_e} = 38.30$ ppm; $CO_{em} = 311.23$ ppm; $CO_{2e} = 0.415$ percent; $HC_d = 4.90$ ppm; $NO_{x_d} = 0.30$ ppm; $CO_{dm} = 8.13$ ppm; $CO_{2d} = 0.037$ pct; $D_{ct} = 5.650$ km.

Then:

(i) $V_{\text{mix}} = [(0.0077934)(12,115)(99.05 - 9.851)(293.15)] / [(101.325)(309.8)] = 78.651 \text{ m}^3$ per test phase.

(ii) $H = [(6.211)(20.5)(3.382)] / [(99.05) - (3.382)(20.5/100)] = 4.378$ grams H_2O per kg dry air.

(iii) $K_h = 1/[1 - 0.0329(4.378 - 10.71)] = 0.8276$

(iv) $CO_e = [1 - 0.01925(0.415) - 0.000323(20.5)](311.23) = 306.68$ ppm.

(v) $CO_d = [1 - 0.000323(20.5)](8.13) = 8.08$ ppm.

(vi) $DF = 13.4/[0.415 + (249.75 + 306.68)10^{-4}] = 28.472$

(vii) $HC_{\text{conc}} = 249.75 - 4.90(1 - 1/28.472) = 245.02$ ppm.

(viii) $HC_{\text{mass}} = (78.651)(576.8)(245.02)10^{-6} = 11.114$ grams per test phase.

(ix) $NO_{x_{\text{conc}}} = 38.30 - 0.30(1 - 1/28.472) = 38.01$ ppm.

(x) $NO_{x_{\text{mass}}} = (78.651)(1913)(38.01)(0.8276) \times 10^{-6} = 4.733$ grams per test phase.

(xi) $CO^{\text{conc}} = 306.68 - 8.08(1 - 1/28.472) = 298.88$ ppm.

(xii) $CO_{\text{mass}} = (78.651)(1164)(298.88)(10^{-6}) = 27.362$ grams per test phase.

(xiii) $CO^{\text{2conc}} = 0.415 - 0.037(1 - 1/28.472) = 0.3793$ percent.

(xiv) $CO_{2\text{mass}} = (78.651)(1843)(0.3793)/100 = 549.81$ grams per test phase.

(2) For the "stabilized" portion of the cold-start test, assume that similar calculations resulted in $HC_{\text{mass}} = 7.184$ grams per test phase; $NO_{x_{\text{mass}}} = 2.154$ grams per test phase; $CO_{\text{mass}} = 64.541$ grams per test phase; and $CO_{2\text{mass}} = 529.52$ grams per test phase. $D_s = 6.070$ km.

(3) For the "transient" portion of the hot-start test, assume that similar calculations resulted in $HC_{mass} = 6.122$ grams per test phase; $NOx_{mass} = 7.056$ grams per test phase; $CO_{mass} = 34.964$ grams per test phase; and $CO_{2mass} = 480.93$ grams per test phase. $D_{ht} = 5.660$ km.

(4) For a 1978 motorcycle with an engine displacement equal to or greater than 170 cc (10.4 cu. in):

(i) $HC_{wm} = 0.43 [(11.114 + 7.184)/(5.650 + 6.070)] + 0.57 [(6.122 + 7.184)/(5.660 + 6.070)] = 1.318$ grams per vehicle kilometer.

(ii) $NOx_{wm} = 0.43 [(4.733 + 2.154)/(5.650 + 6.070)] + 0.57 [(7.056 + 2.154)/(5.660 + 6.070)] = 0.700$ gram per vehicle kilometer.

(iii) $CO_{wm} = 0.43 [(27.362 + 64.541)/(5.650 + 6.070)] + 0.57 [(34.964 + 64.541)/(5.660 + 6.070)] = 8.207$ grams per vehicle kilometer.

(iv) $CO_{2wm} = 0.43 [(549.81 + 529.52)/(5.650 + 6.070)] + 0.57 [(480.93 + 529.52)/(5.660 + 6.070)] = 88.701$ grams per vehicle kilometer.

[54 FR 14553, Apr. 11, 1989, as amended at 59 FR 48515, Sept. 21, 1994; 60 FR 34358, June 30, 1995]