

---

## COMMITTEE OF EXPERTS ON THE TRANSPORT OF DANGEROUS GOODS AND ON THE GLOBALLY HARMONIZED SYSTEM OF CLASSIFICATION AND LABELLING OF CHEMICALS

Sub-Committee of Experts on the Transport of Dangerous Goods  
Twenty-fourth session  
Geneva, 3-10 December 2003  
Item 3 (c) of the provisional agenda

### EXPLOSIVES, SELF-REACTIVE SUBSTANCES AND ORGANIC PEROXIDES

#### Manual of Tests and Criteria, Appendix 5, Example of a test method for vent sizing

Transmitted by the International Council of Chemical Associations (ICCA)

#### 1. Introduction

For a number of years, the test method for emergency vent sizing has been used for organic peroxides in tanks. Since the introduction the following developments have taken place:

- The test method was used not only for emergency vent sizing of portable tanks but over the last years also applied for emergency vent sizing of IBCs. This is not reflected in the test method. No reference is made to IBCs and no calculation example is given, and
- In the USA, the Organic Peroxide Producers Safety Division (OPPSD) of the Society of the Plastic Industry, Inc. (SPI), developed in cooperation with New Mexico Institute of Mining and Technology, New Mexico, an alternative 10 litre test vessel which in principle is equivalent to the test method as currently in the Manual of Test and Criteria, and
- As a part of above mentioned developments, critical evaluation of the current procedure showed that the equations for calculation the heat input due to fire engulfment need minor modification regarding the area exposed to the heat. These modifications result not in significant deviations, but is needed to make the formulas principally correct.

In this information paper, the first draft of the revised Appendix 5 of the Manual of Tests and Criteria, "Example of a test method for vent sizing" is presented. ICCA kindly requests all the experts to comment on this proposal. A formal proposal will be submitted to the July 2004 sub-committee meeting.

#### 2. Proposed changes to Appendix 5

Apart from a number of editorial changes, mainly the following changes are incorporated in the proposed Appendix 5:

- Inclusion of a reference to the applicability of the test method for IBCs, criterion for maximum acceptable pressure allowed during emergency venting of IBCs and addition of calculation example for IBCs,
- Inclusion of test vessel as developed by OPPSD in corporation with New Mexico Tech, USA, and
- Correction of equations (1) and (3) and the calculation examples (extra brackets).

If more convenient, in the formal proposal all the changes compared to the existing Appendix 5, can be highlighted.

### 3. Revised Appendix 5

## APPENDIX 5

### EXAMPLE OF A TEST METHOD FOR VENT SIZING

#### 1. Introduction

This example of a method for vent sizing is used to determine the required emergency vent capacity to be fitted to a specific IBC or portable tank for a particular organic peroxide, Type F or self-reactive substance Type F, or formulations thereof. The method is based on experimental data which indicates that, for organic peroxides or self-reactive substance formulations, the ratio of the minimum emergency vent area to the capacity of the IBC or portable tank is constant and can be determined using a reduced scale tank with a 10 litre capacity. In the tests, the reduced scale tank is heated at rates equivalent to that given by complete fire engulfment or, in the case of insulated IBCs or portable tanks, the heat transfer through the insulation with the assumption that 1% of the insulation is missing (see 4.2.1.13.8 and 4.2.1.13.9 of the Model Regulations). Other methods may be used provided that they adequately size the emergency relief device(s) on an IBC or portable tank to vent all the material evolved during self-accelerating decomposition or a period of not less than one hour of complete fire-engulfment.

***Warning: The method does not take into account the possibility of initiation of deflagration. If this is a possibility, particularly if initiation in the vapour phase can propagate to the liquid phase, then tests should be performed which take this into account.***

#### 2. Apparatus and materials

The reduced scale tank consists of a stainless steel test vessel with a gross volume of 10 l. The top of the vessel is provided with either a 1 mm opening which simulates the pressure relief valve (PRV) of the IBC or portable tank or a real PRV of a diameter which is scaled using the vent area to vessel volume ratio. A second opening simulates the emergency vent opening and is closed by a bursting disk. The diameter of this vent opening can be varied by using orifice plates with different apertures. The bursting pressure of the disk fixed to the 10 l vessel should be equal to the maximum rupture pressure of the bursting disks to be fitted to the IBC or portable tank. This pressure should be lower than the test pressure of the IBC or portable tank involved. Usually, the bursting pressure is set at a level that can cope with the pressures encountered during normal transport conditions such as hydrostatic pressure from the liquid due to turn over of the IBC or portable tank, slopping of the contents, etc. The 10 l vessel should be provided with a bursting disk with a set pressure in the range of the disk(s) fitted on the tank or IBC as to be used in transport. For safety, it is recommended to provide the test vessel with an extra bursting disk (bursting pressure approximately 80% of the design pressure of the 10 l test vessel) with a large opening for additional emergency venting of the test vessel in the event that the chosen orifice diameter is too small.

The outer surface of the test vessel, below the liquid level, is provided with an electrical heating coil or cartridge heaters connected to a power supply. Vessel contents should be heated at a constant rate independent of the heat being generated by the organic peroxide. The resistance of the heating coil or cartridge heaters should be such that, with the power available, the calculated heating rate (see section 3) can be achieved. The whole vessel is insulated with rock wool, cellular glass or ceramic fiber.

The temperature inside the vessel is measured by means of three thermocouples, two located in the liquid phase (near the top and bottom) and one in the gas phase. Two thermocouples are used in the liquid phase to check the homogeneity of the heating. The pressure is recorded by a pressure transducer(s) capable of recording slow and fast (at least 1000 point/sec.) changes of pressure. Examples of test vessels are illustrated in figure A5.1. Additional information may be obtained if the vessel is mounted in a tray designed to collect any solids or liquids ejected.

The tests should be performed at a test site with suitable safety distances. Alternatively, the test can be performed in a bunker provided with sufficient ventilation and vent openings to prevent pressure build-up in it. Explosion-proof electrical equipment should be used in such a bunker to minimize the risk of ignition. **However, the tests should be performed on the assumption that the decomposition products will ignite.**

### 3. Calculation of the heating rate to be used in the test

If an IBC or portable tank is non-insulated, a heat load of the shell as given in 4.2.1.13.8 of the Model Regulations is required. For an insulated IBC or tank, the Model Regulations require that the heat load to the shell be equivalent to the heat transfer through the insulation plus the heat load to the shell on the assumption that 1 % of the insulation is missing.

The following information on the IBC or portable tank and organic peroxide or self-reactive substance is needed for the heating rate calculation:

$F_r$	=	fraction of tank directly heated (1 if non-insulated, 0.01 if insulated)	[-]
$M$	=	total mass of organic peroxide and diluent	[kg]
$K$	=	heat conductivity of the insulation layer	[W.m <sup>-1</sup> .K <sup>-1</sup> ]
$L$	=	thickness of insulation layer	[m]
$U$	=	$K/L$ = heat transfer coefficient	[W.m <sup>-2</sup> .K <sup>-1</sup> ]
$A$	=	wetted area of IBC or portable tank	[m <sup>2</sup> ]
$C_p$	=	specific heat of the organic peroxide or self-reactive substance formulation	[J.kg <sup>-1</sup> .K <sup>-1</sup> ]
$T_{po}$	=	temperature of organic peroxide or self-reactive substance formulation at relieving conditions	[K]
$q_i$	=	indirectly exposed heat	[W]
$q_d$	=	directly exposed heat	[W]
$F$	=	insulation factor	[-]

Heat input,  $q_i$  (W), via indirectly exposed surface (insulated part) is calculated by equations (1) and (2):

$$q_i = 70961 * F * [(1 - F_r) * A]^{0.82} \quad (1)$$

where:

$F$  = insulation factor;

$$F = 1 \text{ for non-insulated shell or}$$

$$F = 2 * \frac{U * (923 - T_{po})}{47032} \text{ for insulated shell.} \quad (2)$$

In the calculation of  $F$  a multiplication factor of 2 is introduced to take into account a 50% loss in insulation efficiency in an incident.

Heat input,  $q_d$  (W), via the directly exposed surface (non-insulated part) is calculated by equation (3):

$$q_d = 70961 * F * [F_r * A]^{0.82} \quad (3)$$

where:

$F$  = insulation factor = 1 (non-insulated)

The overall heating rate,  $dT/dt$  (K/min), due to fire engulfment is calculated by equation (4):

$$dT / dt = \frac{(q_i + q_d)}{M_t * C_p} * 60 \quad (4)$$

**Example 1: insulated portable tank**

For a typical 20 m<sup>3</sup> insulated portable tank:

$F_r$	=	fraction of tank directly heated	=	0.01
$M_t$	=	total mass of organic peroxide and diluent	=	16268 kg
$K$	=	heat conductivity of the insulation layer	=	0.031 W.m <sup>-1</sup> .K <sup>-1</sup>
$L$	=	thickness of the insulation layer	=	0.075 m
$U$	=	heat transfer coefficient	=	0.4 W.m <sup>-2</sup> .K <sup>-1</sup>
$A$	=	wetted area of portable tank	=	40 m <sup>2</sup>
$C_p$	=	specific heat of the organic peroxide form.	=	2000 J .kg <sup>-1</sup> . K <sup>-1</sup>
$T_m$	=	temperature of peroxide at relieving conditions	=	100 °C

and

$$q_i = 70961 * 2 * \frac{0.4 * (923 - 373)}{47032} * [(1 - 0.01) * 40]^{0.82} = 13558 \text{ W}$$

$$q_d = 70961 * 1 * [0.01 * 40]^{0.82} = 33474 \text{ W}$$

$$dT / dt = \frac{(13558 + 33474)}{16268 * 2000} * 60 = 0.086 \text{ K.min}^{-1}$$

**Example 2: non-insulated IBC**

For a typical 1.2 m<sup>3</sup> non-insulated stainless steel IBC (only direct heat input,  $q_d$ ):

$F_r$	=	fraction of tank directly heated	=	1
$M_t$	=	total mass of organic peroxide and diluent	=	1012 kg
$A$	=	wetted area of IBC	=	5.04 m <sup>2</sup>
$C_p$	=	specific heat of the organic peroxide form.	=	2190 J .kg <sup>-1</sup> . K <sup>-1</sup>

and

$$q_d = 70961 * 1 * [1 * 5.04]^{0.82} = 267308 \text{ W}$$

$$q_i = 0$$

$$dT / dt = \frac{(0 + 267308)}{1012 * 2190} * 60 = 7.2 \text{ K.min}^{-1}$$

**4. Procedure**

Fill the test vessel shell with the amount of organic peroxide or self-reactive substance required to give the same degree of fill (by volume of the shell) as to be used in the portable tank (maximum degree of fill 90 %, by volume) and then install the required orifice plate<sup>1</sup> and bursting disk. For example, It is common practice to fit four 250 mm diameter bursting disks to a 20 ton portable tank. This corresponds to a test vessel orifice diameter of about 11 mm.

The vessel is heated at the desired rate by applying power to the heating coil or cartridge heater. A higher than calculated heating rate may be applied initially until a temperature 5 °C above the self-accelerating decomposition temperature (for a 50 kg package) of the organic peroxide or self-reactive substance is reached. The calculated heating rate should be applied once this temperature is reached. The temperature

<sup>1</sup> It is recommended that either small-scale vent experiments (100 - 200 ml scale) or experiments using a very strong vessel (>100 bar) be performed prior to the performance of the 10 l vent test in order to obtain information on the minimum pressure effect from the test substance and on the required orifice diameter to be used in the first 10 l scale vent test.

and pressure in the test vessel are recorded during the entire experiment. After rupture of the bursting disk, the heating should be continued for approximately 30 minutes more to be sure that all dangerous effects are measured. ***Keep distance during the execution of the test and afterwards the vessel should not be approached until the contents have cooled.***

The diameter of the orifice should be varied (if necessary) until a suitable opening is determined at which the maximum recorded pressure does not exceed the pressure as specified in Section 5, Test criteria and method of assessing the results.

The step size used should be related to the options available in practice for the IBC or portable tank, i.e. larger vent sizes or more vents. If necessary, the concentration of the peroxide can be lowered. The test should be performed in duplicate with the minimum total vent area having sufficient capacity.

## 5. Test criteria and method of assessing the results

The minimum or suitable (if it is acceptable to use a vent size larger than the minimum vent size) vent area for the IBC or portable tank can be calculated by using the minimum or suitable orifice vent area as tested in the 10 litre test at which the maximum pressure during venting is:

- for portable tanks not more than test pressure of the portable tank (according to 4.2.1.13.4 portable tank shall be designed for a test pressure of at least 0.4 MPa),
  - for IBC not more than 200 kPa gauge pressure, as tested according 6.5.4.8.4, or higher under an approval granted by the competent authority,
- and the volumes of the test vessel and IBC or portable tank.

The minimum total IBC or portable tank vent area is given by:

$$\text{For IBCs:} \quad A_{\text{IBC}} = V_{\text{IBC}} * (A_{\text{test vessel}} / V_{\text{test vessel}})$$

$$\text{For portable tanks:} \quad A_{\text{portable tank}} = V_{\text{portable tank}} * (A_{\text{test vessel}} / V_{\text{test vessel}})$$

Where:

$A_{\text{test vessel}}$	=	Area of venting of 10 litre test vessel	[m <sup>2</sup> ]
$A_{\text{IBC}}$	=	Area of venting of IBC	[m <sup>2</sup> ]
$A_{\text{portable tank}}$	=	Area of venting of portable tank	[m <sup>2</sup> ]
$V_{\text{test vessel}}$	=	Volume of 10 litre test vessel	[m <sup>3</sup> ]
$V_{\text{IBC}}$	=	Volume of IBC	[m <sup>3</sup> ]
$V_{\text{portable tank}}$	=	Volume of portable tank	[m <sup>3</sup> ]

*Example:*

For a typical organic peroxide in a 20 m<sup>3</sup> insulated portable tank:

$A_{\text{test vessel}}$	=	Minimum suitable orifice area found in test	=	9.5 · 10 <sup>-5</sup> m <sup>2</sup>
$V_{\text{portable tank}}$	=	Volume of portable tank	=	20 m <sup>3</sup>
$V_{\text{test vessel}}$	=	Volume of test vessel	=	0.01 m <sup>3</sup>
$A_{\text{portable tank}}$	=	20 * (9.5 · 10 <sup>-5</sup> / 0.01)	=	0.19 m <sup>2</sup>

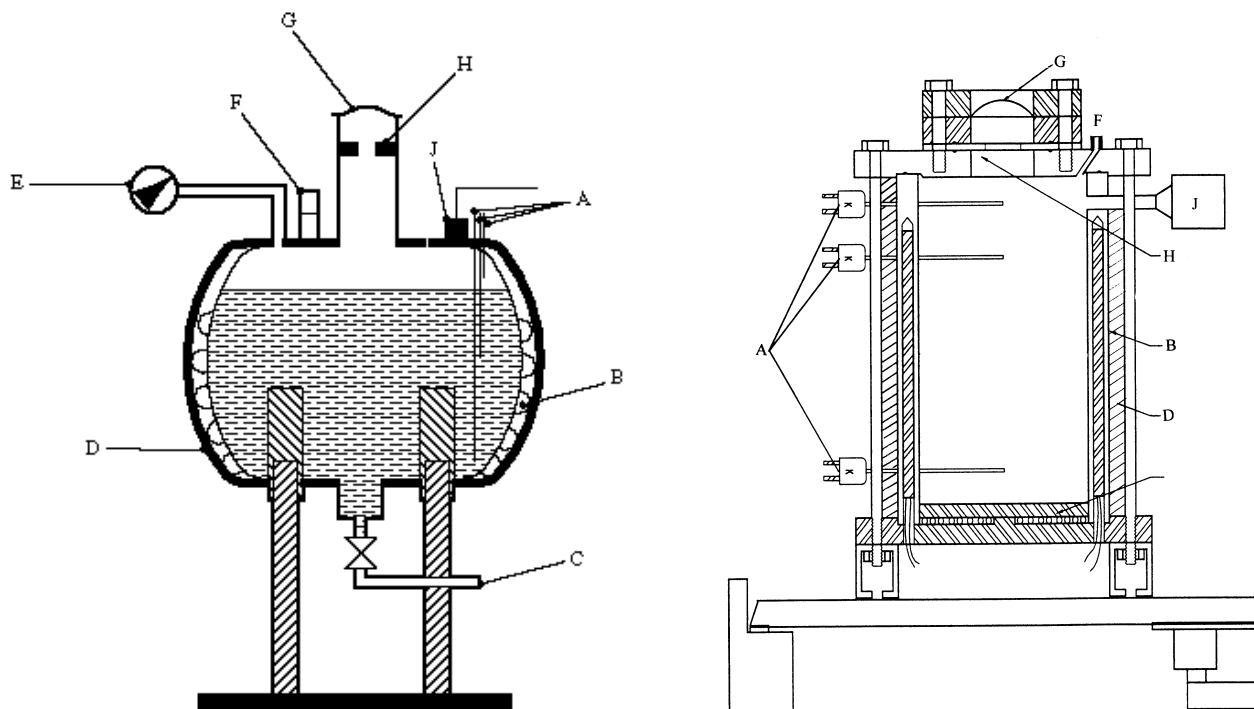

- 
- (A) Thermocouples (two in liquid and one in vapour space)
  - (B) Heating coil/heating cartridge
  - (C) Drain line, optional
  - (D) Insulation
  - (E) Manometer, optional
  - (F) Pressure relief valve, optional
  - (G) Bursting disk
  - (H) Orifice plate
  - (J) Pressure transducer or pressure relief valve & transducer on tee
- 

**Figure A5.1: 10 LITRE VESSELS FOR VENTING TESTS**

\_\_\_\_\_