



**Economic and Social
Council**

Distr.
GENERAL

TRANS/WP.15/AC.2/2002/1/Add.7
8 November 2001

ENGLISH
Original: FRENCH

ECONOMIC COMMISSION FOR EUROPE

INLAND TRANSPORT COMMITTEE

Working Party on the Transport of Dangerous Goods

Joint Meeting of Experts on the Regulations
annexed to the European Agreement concerning
the International Carriage of Dangerous Goods
by Inland Waterways (ADN)*
(Fifth session, 21-25 January 2002)

RESTRUCTURING OF THE REGULATIONS ANNEXED TO ADN

Part 8: Provisions for vehicle crews, equipment, operation and documentation

Addendum 7

Note by the secretariat

The secretariat presents below the restructured Part 8 of the draft Regulations annexed to the European Agreement concerning the International Carriage of Dangerous Goods by Inland Waterways (ADN).

* This meeting is organized jointly by the Economic Commission for Europe and the Central Commission for the Navigation of the Rhine.

PART 8

Provisions for vehicle crews, equipment, operation and documentation

Part 8: Contents

- 8.1 General requirements applicable to vessels and equipment**
- 8.1.1 reserved
- 8.1.2 Documents**
- 8.1.3 reserved
- 8.1.4 Fire-extinguishing arrangements**
- 8.1.5 Special equipment**
- 8.1.6 Checking and inspection of equipment**
- 8.1.7 Electrical installations**
- 8.1.8 Certificate of approval**
- 8.1.9 Provisional certificate of approval**
- 8.1.10 Loading journal**
- 8.2 Requirements concerning training**
- 8.2.1 **General requirements concerning training of experts**
- 8.2.2 **Special requirements concerning training of experts**
- 8.2.3 **Training**
- 8.2.3.1 **Training syllabus and subjects**
- 8.2.3.1.1 **Basic course**
- 8.2.3.1.2 **Refresher and advanced training courses based on the certified basic courses referred to in 8.2.3.1.1**
- 8.2.3.2 **Purpose and content of training course**
- 8.2.3.3 **Approval of training courses**
- 8.2.3.4 **Conduct of training courses**
- 8.2.3.5 **Examinations**
- 8.2.3.5.1 **Basic training courses**
- 8.2.3.5.2 **Specialization course on “Gases” and “chemicals”**
- 8.2.3.6 **ADN specialized knowledge certificate**

- 8.3** **Miscellaneous requirements to be complied with by the crew**
- 8.3.1** **Persons authorized on board**
- 8.3.2** **Portable lamps**
- 8.3.3** **Admittance on board**
- 8.3.4** **Prohibition on smoking, fire and naked light**
- 8.3.5** **Risk of sparking**
- 8.4** reserved
- 8.5** reserved
- 8.6** **Document**
- 8.6.1** **Certificate of approval**
- 8.6.1.1** **Model for a certificate of approval for dry cargo vessel**
- 8.6.1.2** **ADN section of the model single certificate for the provisional inspection certificate and the provisional certificate of approval**
- 8.6.1.3** **Model for a certificate of approval for tank vessels**
- 8.6.1.4** **ADN section of the model single certificate for the provisional inspection certificate and the provisional certificate of approval**
- 8.6.2** **Certificate of special knowledge of ADN according to 8.2.1.2, 8.2.1.4 or 8.2.1.5**
- 8.6.3** **ADN checklist**
- 8.6.4** **Discharge of residual quantities and stripping system**
- 8.6.4.1** **Device for the discharge of residual quantities**
- 8.6.4.2** **Test of the stripping system**
- 8.6.4.3** **Certificate for the test of the stripping system**

8.1 General requirements applicable to vessels and equipment

8.1.1 reserved

~~210 381~~ 8.1.2 Documents

~~(1)~~8.1.2.1 In addition to the documents required by other regulations, the following documents shall be kept on board:

- (a) The vessel's certificate of approval referred to in 8.1.8;
- (b) Transport documents (~~see marginal 602 (6)~~): referred to in 5.4.1 for
~~The transport documents shall cover all dangerous goods on board [and, where necessary the container packing certificate (see 5.4.2)];~~
- (c) The instructions in writing referred to in ~~marginal 210 385~~ prescribed in 5.4.3 for all dangerous goods on board;
- ~~(d) The loading journal required by marginal 210 284;~~
- (d)(e) A copy of the ADN with its Annexes A, B.1 and B.2 (at least ~~Annex A and Annex B.2~~) and its Annexes C, D.1 and D.2; its annexed Regulations [which may be a copy which can be consulted by electronic means at any time];
- ~~(f) The certificate referred to in marginal 210 315 and, where applicable, marginal 210 317 or marginal 210 318;~~
- [(e) The inspection certificate of the insulation resistance of the electrical installations prescribed in 8.1.7;
- (f) The inspection certificate of the fire-extinguishing equipment and fire-hoses prescribed in 8.1.6.1;]
- (g) A book in which all required measurement results are recorded;
- ~~(h) For vessels which have to conform to the conditions of damage control, the damage control plan;~~
- [(h) A copy of the relevant text of the special authorizations referred to in 1.5 if the transport operation is performed under this/these special authorization(s).]

[8.1.2.2] In addition to the documents prescribed in 8.1.2.1, the following documents shall be carried on board dry cargo vessels.

- (a) The loading plan prescribed in 7.1.4.11;
- (b) The ADN specialized knowledge certificate prescribed in 8.2.12;
- (c) For vessels which have to conform to the conditions of damage-control (see 9.1.0.95)
 - a damage-control plan;
 - the documents concerning intact stability as well as all conditions of intact stability taken into account for the damaged stability calculation in a form the master understands;
 - the certificate of the classification society (see 9.1.0.88 or 9.2.0.88).]

[8.1.2.3] In addition to the documents prescribed in 8.1.2.1, the following documents should be carried on board tank vessels:

- (a) The loading journal prescribed in 7.2.4.11;
- (b) The ADN specialized knowledge certificate prescribed in 8.2.1.2, and, for the carriage of gases for which type G is prescribed in 3.2, Table C, column (6), the specialized knowledge certificate for the carriage of gases in tank vessels (see 8.2.1.3) and, for the carriage of chemicals for which type C is prescribed in 3.2, Table C, column (6), the specialized knowledge certificate for the carriage of chemicals in tank vessels (see 8.2.1.4);
- (c) For vessels which have to conform to the conditions of damage-control (see 9.3.1.15 or 9.3.2.15)
 - a damage-control plan;
 - the documents concerning intact stability as well as all conditions of intact stability taken into account for the damaged stability calculation in a form the master understands;
- (d) The documents concerning the electrical installations prescribed in 9.3.1.50, 9.3.2.50 or 9.3.3.50;
- (e) The classification certificate prescribed in 9.3.1.8, 9.3.2.8 or 9.3.3.8;

- (f) The flammable gas detector certificate prescribed in 9.3.1.8.3, 9.3.2.8.2 or 9.3.3.8.3;
- (g) The inspection certificate for the pipes for loading and unloading prescribed in 8.1.6.2;
- (h) The inspection certificate for the stripping installation prescribed in 8.1.4.2;
- (i) In the event of the carriage of goods having a melting point $\geq 0^{\circ}$ C, heating instructions;
- (j) The inspection certificate for the pressure relief and vacuum relief valves prescribed in 8.1.6.5.]

[8.1.2.4 The instructions in writing referred to in 5.4.3 shall be handed to the master before loading. They shall be kept readily at hand in the wheelhouse.

On board dry cargo vessels, the transport documents shall be handed to the master before loading and on board tank vessels they shall be handed to him after loading.]

[8.1.2.5 The instructions in writing which are not applicable to the dangerous goods on board the vessel shall be kept separate from those which are applicable so as to avoid any confusion.]

[8.1.2.6 The presence on board of the certificate of approval is not required in the case of pusher barges which are not carrying dangerous goods, provided that the following additional particulars are indicated, in identical lettering, on the metal plate furnished by [CEVNI]:

Number of the certificate of approval: ...
issued by: ...
valid until: ...

The barge-owner shall thereafter keep the certificate of approval in his possession.

The similarity of the particulars on the plate and those contained in the certificate of approval shall be certified by a competent authority which shall affix its stamp to the plate.]

[8.1.2.7 The presence on board of the certificate of approval is not required in the case of dry cargo barges or tank barges carrying dangerous goods provided that the metal plate furnished by [CEVNI] is supplemented by a second metal plate reproducing by photo-optical means a copy of the entire certificate of approval.

The barge-owner shall thereafter keep the certificate of approval in his possession.

The similarity of the particulars on the metal plate and the certificate of approval shall be certified by an inspection commission which shall affix its stamp to the plate.]

[**8.1.2.8** All documents shall be drawn up in a language the master is able to read and understand and if that language is not English, French or German, in English, French or German unless international transport tariffs, if any, or agreements concluded between the countries concerned in the transport operation provide otherwise.] They shall also be drawn up in one of these languages.

8.1.2.9 8.1.2.1 (b), 8.1.2.1 (g), 8.1.2.4 and 8.1.2.5 do not apply to oil separator vessels or supply vessels. 8.1.02.1 (c) does not apply to oil separator vessels.

[**8.1.3** reserved]

210 240 Fire-extinguishing arrangements

8.1.4

(+) In addition to the fire-extinguishing appliances prescribed in ~~marginal 210 001 (1)~~, [...], each vessel shall be equipped with at least two additional hand fire-extinguishers having the same capacity. The fire-extinguishing agent contained in these additional hand fire-extinguishers shall be suitable for fighting fires involving the dangerous goods carried.

210 260 Special equipment

8.1.5

(+) ~~8.1.5.1 When this is required in Part II~~ Insofar as the provisions of Chapter 3.2, Tables A or C require, the following equipment shall be available on board:

- (a)[PP:] for each member of the crew, a pair of protective goggles, ~~a full face mask with suitable respirator~~, a pair of protective gloves, ~~and boots, and~~ a protective suit [and a suitable pair of protective shoes (or protective boots, if necessary). On board tank vessels, protective boots are required in all cases.];
- (b)[EP:] a suitable escape device for each person on board;
- (f)[EX:] a flammable gas detector with the instructions for its use;
- (g)[TOX:] a toximeter with the instructions for its use;
- (e)[A:] ~~two self-contained~~ a breathing apparatus [ambient air-dependent];

~~(d)~~ ————— two safety harnesses;

~~(e)~~ ————— a rescue winch;

8.1.5.2 [Materials and additional protective equipment] specified by the consignor in the instructions shall be provided by the consignor [and shall be available on board].

~~(2)~~**8.1.5.3** For pushed convoys or side-by-side formations under way, it shall be sufficient, however, if the pusher tug or the vessel propelling the formation is equipped with the special equipment referred to in 8.1.5.1-~~(1)~~ above, when this is required in ~~Part H~~ Chapter 3.2, Tables A or C.

210-280

Checking and inspection of equipment

8.1.6

~~(1)~~8.1.6.1 The fire-extinguishing appliances and hoses shall be inspected at least once every two years by persons authorized for this purpose by the competent authority. [Proof of inspection shall be affixed to the fire-extinguishing appliances. A certificate concerning this inspection shall be carried on board.]

~~(2)~~8.1.6.2 The ~~pipes~~ [hoses] for loading and unloading shall be inspected once a year by persons authorized for this purpose by the competent authority. [Proof of inspection shall be affixed to the fire-extinguishing appliances. A certificate concerning this inspection shall be carried on board.]

~~(3)~~8.1.6.3 The special equipment referred to in 8.1.5.1 ~~marginal 210-260~~ ~~(1)~~ and the gas detection system shall be inspected in accordance with the instructions of the manufacturer concerned ~~either by the manufacturer himself or by persons authorized [for this purpose] or by the competent authority.~~ [Proof of inspection shall be affixed to the fire-extinguishing appliances. A certificate concerning this inspection shall be carried on board.]

[8.1.6.4 The measuring instruments prescribed in 8.1.5.1 shall be checked each time before use by the user in accordance with the instructions for use.

8.1.6.5 The pressure relief and vacuum relief valves prescribed in 9.3.1.22, 9.3.2.22 and 9.3.3.22 shall be inspected on each renewal of the certificate of approval by the manufacturer or by a firm approved by the manufacturer. A certificate concerning this inspection shall be carried on board.

8.1.6.6 The stripping system referred to in 9.3.2.25.10 or 9.3.3.25.10 shall be subjected to a water test before its first use or after a modification. The test and the establishment of the residual quantities shall be carried out in accordance with the provisions of 8.6.4.2. The certificate concerning the test referred to in 8.6.4.3 shall be carried on board.]

~~210 251~~
8.1.7

Electrical installations

The insulation resistance of the electrical installations, the earthing and the [flameproof] electrical equipment shall be inspected whenever the certificate of approval is renewed and, in addition, within the third year from the date of issue of the certificate of approval by a person authorized for this purpose by the competent authority. An appropriate inspection certificate shall be kept on board.

8.1.8 Certificate of approval

8.1.8.1 [Dry cargo vessels carrying dangerous goods in quantities greater than exempted quantities, the vessels referred to in 7.1.2.19.1] tank vessels carrying dangerous goods and the vessels referred to in 7.2.2.19.3 shall be provided with an appropriate certificate of approval.

~~(2)~~**8.1.8.2** The certificate of approval shall attest that the vessel has been inspected and that its construction and equipment comply with the applicable provisions of ~~this Annex~~ ADN.

~~(3)~~**8.1.8.3** The certificate of approval shall be issued in accordance with the requirements and procedures set out in ~~Annex C~~ ADN.

It shall conform to the model ~~No.1 in Appendix 1 of this Annex~~ 8.6.1.1 or 8.6.1.3.

[The competent authority may refrain from subjecting a vessel to inspection provided that the certificate issued by a recognized classification society attests that the construction and equipment of the vessel meet the applicable requirements of ADN.]

~~(4)~~**8.1.8.4** The certificate of approval shall be valid for not more than five years. The date on which the period of validity expires shall be shown on the certificate. The competent authority which issued the certificate may, without inspection of the vessel, extend the validity of the certificate by not more than one year. Such extension may be granted only once within two periods of validity.

~~(5)~~**8.1.8.5** If the vessel's hull or equipment has undergone alterations liable to reduce the safety as regards the carriage of dangerous goods or has sustained damage affecting such safety, the vessel shall undergo a further inspection in accordance with 8.1.8.3 ~~(3)~~ ~~above~~ without delay.

~~(6)~~**8.1.8.6** The certificate of approval may be withdrawn if the vessel is not properly maintained or if the vessel's construction or equipment no longer complies with the applicable provisions of ~~this Annex~~ ADN.

~~(7)~~**8.1.8.7** The certificate of approval may only be withdrawn by the authority by which it has been issued.

Nevertheless, in the cases referred to in ~~(5) and (6) above~~ 8.1.8.5 and 8.1.8.6, the competent authority of the State in which the vessel is staying may prohibit its use for the carriage of those dangerous goods for which the certificate is required. For this purpose it may withdraw the certificate until such time as the vessel again complies with the applicable provisions of ~~this Annex~~ ADN. In that case it shall notify the competent authority which issued the certificate.

~~(8)~~**8.1.8.8** Notwithstanding ~~(7) above~~ 8.1.8.7, any competent authority may amend or withdraw the certificate of approval at the request of the vessel's owner, provided that it so notifies the competent authority which issued the certificate.

[8.1.8.9 The competent authority shall include the following particulars in the certificate of approval of double-hull vessels meeting the additional requirements of 9.1.0.80 to 9.1.0.95 or 9.2.0.80 to 9.2.0.95:

“The vessel meets the additional requirements for double-hull vessels of 9.1.0.80 to 9.1.0.95” or

“The vessel meets the additional requirements for double-hull vessels of 9.2.0.80 to 9.2.0.95.”]

~~210 283~~
8.1.9

Provisional certificate of approval

~~(1)~~**8.1.9.1** For a vessel which is not provided with a certificate of approval, a provisional certificate of approval of limited duration may be issued in the following cases, subject to the following conditions:

- (a) The vessel complies with the applicable provisions of ADN, ~~this Annex~~, but the certificate of approval could not be issued in time. The provisional certificate of approval shall be valid for an appropriate period but not exceeding three months.
- (b) The vessel does not comply with every applicable provisions of ADN ~~this Annex~~ after sustaining damage. In this case the provisional certificate of approval shall be valid only for a single specified voyage and for a specified cargo. The competent authority may impose additional conditions.

~~(2)~~**8.1.9.2** The provisional certificate of approval shall conform to the model ~~No. 2 in Appendix 1 to this Annex~~ in 8.6.1.2 or 8.6.1.4.

~~210 284~~
8.1.10

Loading journal

All tank vessels shall be provided with a loading journal. The original of the loading journal shall be kept on board for not less than 12 months after the last entry is made.

The first loading journal shall be issued by the authority which issued the certificate of approval. Subsequent journals may be issued by authorities competent to do so.

8.2 Requirements concerning training

8.2.1 General requirements concerning training of experts

~~(1)8.2.1.1~~ An expert ~~shall be on board the vessel.~~ This person shall not be less than 18 years of age.

~~(2)8.2.1.2~~ An expert is a person who has a special knowledge of the ADN. Proof of this knowledge shall be furnished by means of a certificate from a competent authority or from an agency recognized by the competent authority.

This certificate shall be issued to persons who, after training, have successfully passed a qualifying ADN examination.

[8.2.1.3 The experts referred to in 8.2.1.2 shall take part in a basic training course. Training shall take place in the context of classes approved by the competent authority. The primordial objective of the training is to make the experts aware of the hazards of the carriage of dangerous goods and provide them with the necessary basic knowledge to reduce the dangers of an incident to a minimum, to enable them to take the necessary measures to ensure their own safety, general safety and the protection of the environment and to limit the consequences of the incident. This training, which shall include individual practical exercises, takes the form of a basic course; it shall cover at least the topics referred to in 8.2.2.3.2.]

[8.2.1.4 Experts for the carriage of gases shall take part in an advanced course covering at least the topics referred to in 8.2.2.3.3. Training shall take place in the context of classes approved by the competent authority. An expert certificate shall be issued to persons who, after training, have successfully passed an examination concerning the carriage of gases and have produced evidence of not less than one year's work on board a type G vessel during a period of two years prior to or following the examination.]

[8.2.1.5 Experts for the carriage of chemicals shall take part in an advanced course covering at least the topics referred to in 8.2.2.3.4. Training shall take place in the context of classes approved by the competent authority. An expert certificate shall be issued to persons who, after training, have successfully passed an examination concerning the carriage of chemicals and have produced evidence of not less than one year's work on board a type C vessel during a period of two years prior to or following the examination.]

[8.2.1.6 After five years the expert shall furnish proof, in the form of relevant particulars entered in the certificate by the competent authority or by a body recognized by it, of participation in a refresher or advanced course taken in the last year prior to the expiry of the certificate, covering at least the topics referred to in 8.2.2 and comprising current new developments in particular. The new period of invalidity shall begin on the expiry date of the certificate; in other cases it shall begin on the date of the certificate of participation in the course.]

[8.2.1.7 After five years, the expert for the carriage of gases shall furnish proof, in the form of relevant particulars entered in the certificate by the competent authority or by a body recognized by it,

- that during the year preceding the expiry of the certificate, he has participated in a refresher or advanced course covering at least the topics referred to in 8.2.2.3.3 and comprising current new developments in particular, or
- that during the previous two years he has performed a period of work of not less than one year on board a type G tank vessel.

When the refresher or advanced training course is taken in the year preceding the date of expiry of the certificate, the new period of validity shall begin on the expiry date of the preceding certificate, ~~in other cases it shall begin on the date of the certificate of participation in the course~~ but in other cases it shall begin on the date of certification of participation in the course.]

[8.2.1.8 After five years, the expert for the carriage of chemicals shall furnish proof, in the form of relevant particulars entered in the certificate by the competent authority or by a body recognized by it,

- that during the year preceding the expiry of the certificate, he has participated in a refresher or advanced course covering at least the topics referred to in 8.2.2.3.4 and comprising current new developments in particular, or
- that during the previous two years he had performed a period of work of not less than one year on board a type C tank vessel.

When the refresher or advanced training course is taken in the year preceding the date of expiry of the certificate, the new period of validity shall begin on the expiry date of the preceding certificate, ~~in other cases it shall begin on the date of the certificate of participation in the course~~ but in other cases it shall begin on the date of certification of participation in the course.]

~~(8.2.1.9~~ **8.2.1.9** The document attesting training and experience in accordance with the requirements of Chapter V of the STCW Code on Training and Qualifications of Masters, Officers and Ratings of Tankers [carrying LPG/LNG] shall be equivalent

to the certificate referred to in ~~(2) above~~ 8.2.1.4, provided it has been recognized by a competent authority. No more than five years shall have passed since the date of issue or renewal of such a document.

[8.2.1.10 The document attesting training and experience in accordance with Chapter V of the STCW Code for officers concerning personnel in charge of cargo on tank vessels carrying chemicals in bulk shall be equivalent to the certificate referred to in 8.2.1.5, provided it has been recognized by a competent authority. No more than five years shall have passed since the date of issue or renewal of such a document.

8.2.1.11 The certificate shall conform to the model in 8.6.2.]

[8.2.2 Special requirements concerning training of experts

8.2.2.1 Theoretical knowledge and practical abilities shall be acquired as a result of training in theory and practical exercises. Theoretical knowledge shall be tested by an examination. During the refresher and advanced courses exercises and tests shall ensure that the participant takes an active role in the training.

8.2.2.2 The training organizer shall ensure that participants have a good knowledge of the subject and shall take into account the latest developments concerning the regulations and the requirements for training in the carriage of dangerous goods. Teaching shall relate closely to practice. In accordance with the approval, the teaching syllabus shall be drawn up on the basis of the topics referred to in 8.2.2.3.2 to 8.2.2.3.4. Basic training and the refresher and advanced courses shall comprise individual practical exercises (8.2.2.3.1).]

8.2.2.3 Organization of expert training

[8.2.2.3.1 Basic training and the refresher and advanced courses shall be organized in the context of basic courses (see 8.2.2.3.2) and if necessary specialization courses (see 8.2.2.3.2 and 8.2.2.3.4). The courses referred to in 8.2.2.3.2 may comprise three variants: transport of dry cargo, transport in tank vessels and combined transport of dry cargo and using tank vessels.]

8.2.2.3.2 Basic training shall comprise at least the following topics and practical exercises:

- (a) General requirements relating to the carriage of dangerous goods, e.g.:

General:

structure of ADN, temperature data, mass, quantity, concentration, marking of vessels, instructions in writing;

Carriage of dry goods:

[labelling of packages;]

Carriage in tank vessels:

degree of filling, calculation of contents, measurement of level, sampling, checklist, overfilling, pumping;

- (b) Definition of terms (e.g. liquids, solids, viscosity, gases and vapours), basic knowledge of products;
- (c) Nature of risks such as combustion, explosion, sources of ignition, electrostatic charge, toxicity, ~~radioactivity~~, corrosivity, danger to the aquatic environment;
- (d) Measures to avoid accidents, prevention of explosion;
- (e) Measures to be taken in the event of an accident or an incident (first aid, “keep-off” signal, emergency call, safety of traffic, use of appliances such as fire-extinguishers and personal protective equipment, etc.);
- (f) Tasks of the crew and of the expert with respect to the carriage of dangerous goods;
- (g) Equipment of vessels carrying dangerous goods, e.g. flammable gas detector, oxygen meters and toximeters; tests to be carried out before entering spaces; ~~certificates attesting a gas-free condition;~~ [gas-freeing certificate];
- (h) Practical exercises, in particular with respect to entry into spaces, use of fire-extinguishers, fire-fighting equipment and personal protective equipment as well as flammable gas detectors, oxygen meters and toximeters.

~~(3)~~**8.2.2.3.3** Gas training shall comprise at least the topics listed below and shall include practical exercises:

- (a) Common properties of gases:

compressibility, mixtures and partial pressures, expansion at constant pressure, laws of Boyle-Mariotte and Gay-Lussac, relative density, volume; density and critical pressure;
- (b) Purging and sampling of gases;

- (c) Explosion hazards presented by liquefied gases (e.g. LPG);
- (d) Measurement of gas concentration, tests to be carried out before entering spaces; ~~certificates attesting a gas-free condition;~~
- (e) Knowledge of products:
chemical and physical properties, mixtures, compounds and chemical formulae - hydrocarbons, ammonia;
- (f) Liquids and vapours:
evaporation and condensation, relation between liquid volume and vapour volume;
- (g) Action to be taken in case of emergency;
- (h) Operational procedures:
loading and discharging, quick-action stop valve systems, effects of temperature, filling ratios, overfilling, compressors, pumps, functioning of excess flow valves, leakage;
- (i) Participation in appropriate fire-fighting drills and appropriate training in the use of protective breathing apparatus.

~~(3)~~ **8.2.2.3.4** Chemicals training shall comprise at least the topics listed below and shall include practical exercises:

- (a) Common properties of gases:
compressibility, mixtures, expansion at constant pressure, laws of Boyle-Mariotte and Gay-Lussac, vapour/density ratio and boiling point, relative density, volume;
- (b) Sampling of chemicals;
- (c) Explosion hazards presented by chemicals;
- (d) Measurement of gas concentration, cargo tank-washing, gas-freeing, venting, tests to be carried out before entering spaces, gas-freeing certificates;

- (e) Knowledge of products:
chemical and physical properties, mixtures, compounds and chemical formulae - hydrocarbons, toxic substances, acids and alkalis - polymerization and oxidation;
- (f) Liquids and vapours:
evaporation and condensation, relation between liquid volume and vapour volume;
- (g) Action to be taken in case of emergency;
- (h) Operational procedures:
loading and discharging, vapour recovery systems, quick-action stop valve systems, effects of temperature, filling ratios, overfilling, types of pump, ~~contamination~~, [leakage];
- (i) Participation in appropriate fire-fighting drills and appropriate training in the use of protective breathing apparatus.

8.2.3 Training

8.2.3.1 Training syllabus and subjects

6.1.2.2 Basic course

8.2.3.1.1

Basic course on the transport of dry cargo

Prior training: none
 Knowledge: ADN in general, ~~Annexes A and B.1~~ [except Chapter 3.2, Table C, 7.2 and 9.3]
 Authorized for: vessels carrying dry cargo only

Basic course on transport by tank vessels

Prior training: none
 Knowledge: ADN in general, ~~Annexes A, B.1 and B.2 (excluding marginals 311 000-320 999 and 321 000-330 999)~~ [except Chapter 3.2, Tables A and B, 7.1, 9.1, 9.2, 9.3.1 and 9.3.2]
 Authorized for: type N tank vessels only

Combined basic course dry cargo and transport in tank vessels

Prior training: none
 Knowledge: ADN in general, ~~Annexes A, B.1 and B.2 (excluding~~

~~marginals 311-000-320-999 and 321-000-330-999)~~
including 9.3.1 and 9.3.2
Authorized for: dry cargo vessels and type N tank vessels

~~6.1.2.3~~
8.2.3.1.2 Refresher and advanced training courses based on the certified basic courses referred to in ~~paragraph 6.1.2.2~~ 8.2.3.1.1

Prior training: Valid ADN certificate referred to in ~~paragraph 6.1.2.2~~ with a refresher course in accordance with ~~marginals 10-315, 210-315, 10-315/210-315, 210-317 or 210-318~~ 8.2.3.1.1
[Authorized for: depending on the refresher and advanced course taken: only dry cargo vessels, only type N tank vessels or dry cargo vessels and type N tank vessels

Specialization course in gases

Prior training: basic tank vessel or combined training
Knowledge: ADN, in particular, knowledge of loading, carriage, unloading and handling of gases
Authorized for: tank vessels of types N and G]

Specialization course in chemicals

Prior training: basic tank vessel or combined training
Knowledge: ADN, in particular, knowledge of loading, carriage, unloading and handling of chemicals
Authorized for: tank vessels of types N and C

~~6.2~~ **8.2.3.2 Purpose and content of training course**

~~6.2.1~~
8.2.3.2.1 The following provisions are applicable to the approval of the expert training courses in accordance with ~~marginal 10-315 or marginals 210-315, 210-317 and 210-318~~ 8.2.1.2, 8.2.1.4 and 8.2.1.5

~~6.2.2~~
8.2.3.2.2 The purpose of the training courses is to provide the theoretical and practical knowledge referred to in ~~paragraph 6.1.2~~ 8.2.2.3.2, 8.2.2.3.4 or 8.2.2.3.5.

~~6.2.2.1~~
8.2.3.2.3 Initial training [Planning of initial training]

The following periods of training are to be completed:

basic training course on dry cargo vessels:	24 lessons of 45 minutes
each basic training course on tank vessels:	24 lessons of 45 minutes
each combined basic training course:	32 lessons of 45 minutes
each specialization course on gases:	16 lessons of 45 minutes
each specialization course on chemicals:	16 lessons of 45 minutes

One day's training may comprise a maximum of eight lessons.

If theoretical training is by correspondence, equivalences with the above-mentioned lessons shall be determined. Training by correspondence must be completed within nine months.

Approximately 30% of basic training shall be devoted to practical exercises. These practical exercises shall if possible be completed during the theoretical training period; in any event, they shall take place not more than three months following the completion of theoretical training.

~~6.2.2.2~~
8.2.3.2.4 Refresher and further training courses [Planning of refresher and advanced training courses]

Additional training courses are intended to refresh existing knowledge and provide information on new developments in the technical and legal fields and in relation to subject matter.

These courses shall take place before the expiry of the period referred to in ~~marginal 10 315 (5) or, where pertinent, in marginals 210 315 (5), 210 317 (5) and 210 318 (5)~~ 8.2.1.6, 8.2.1.7 or 8.2.1.8.

The duration of training courses shall be as follows:

Basic refresher course:

- | | |
|---|-------------------------------|
| – dry cargo vessels | 16 lessons of 45 minutes each |
| – tank vessels | 16 lessons of 45 minutes each |
| – combined dry cargo vessels and tank vessels | 16 lessons of 45 minutes each |

Specialization refresher course on gases:	8 lessons of 45 minutes each
Specialization refresher course on chemicals:	8 lessons of 45 minutes each

Each day of training may comprise not more than eight lessons.

If the theoretical training is by correspondence, equivalences to the above-mentioned lessons shall be determined. Training by correspondence shall be completed within a period of nine months.

Approximately 50% of basic training shall be devoted to practical exercises. Practical exercises shall, where possible, be undertaken during the period of theoretical training; in any event, they shall be completed not later than three months following the completion of theoretical training.

~~6.3~~ **8.2.3.3 Approval of training courses**

~~6.3.1~~
8.2.3.3.1 Training courses shall be approved by the competent authority.

~~6.3.2~~
8.2.3.3.2 Approval shall be granted only on written application. ~~Application for approval may be made by individuals or corporate entities.~~

8.2.3.3.3 Applications for approval shall be accompanied by:

- (a) the detailed course curriculum showing the course topics and the length of time to be devoted to them, as well as the teaching method envisaged;
- (b) the roster of teaching staff, listing their qualifications and the subjects to be taught by each one;
- (c) information on classrooms and teaching materials, as well as on the facilities available for practical exercises;
- (d) enrolment requirements.

[8.2.3.3.4 The competent authority shall be responsible for monitoring training courses and examinations.

~~6.3.4.1~~
8.2.3.3.5 The competent authority shall grant approval in writing. Such approval shall be subject to the following conditions, inter alia:

- (a) training courses shall conform to the information accompanying the application for approval;
- (b) the competent authority may send inspectors to attend training courses;
- (c) the timetables for the various training courses shall be notified in advance to the competent authority;
- (d) approval may be withdrawn in the event of failure to abide by the approval conditions.

8.2.3.3.6 The approval document shall indicate whether the course in question is a basic training course, a specialization course or a refresher and advanced training course.

~~6.3.4.2~~
8.2.3.3.7 If, after approval is granted, the organizer of the training course wishes to change conditions affecting the approval, he shall seek the prior agreement of the competent authority. This provision shall apply in particular to the replacement of serving teachers and amendments to syllabuses.

6.4 8.2.3.4 Conduct of training courses

6.4.1 Training courses shall take account of the current developments in the various subjects taught. The course organizer shall be responsible for ensuring that recent developments are brought to the attention of, and properly understood by, teachers.

6.5 8.2.3.5 Examinations

6.5.1 8.2.3.5.1 Basic training courses

8.2.3.5.1.1 After initial training, [including practical exercises,] and ADN basic training examination shall be taken. This examination shall be held either immediately after the training courses or within six months following the completion of such courses.

[8.2.3.5.1.2 In the examination the candidate shall furnish evidence that, in accordance with the basic training course, he has the knowledge, understanding and capabilities required of an expert on board a vessel.]

8.2.3.5.1.3 The list of questions drawn up by the competent authority shall be used for this purpose.

Each competent authority shall determine the conditions of the ADN examination on the basis of the programme described in ~~marginals 10-315 (3) or 210-315 (3)~~ 8.2.2.3.2 and the list of questions drawn up by the competent authority.

[8.2.3.5.1.4 In the event of multiple training courses, a single examination may be organized.]

8.2.3.5.1.5 [The examination shall be written.] Candidates shall be asked 30 questions. The examination shall last 60 minutes. It is deemed to have been passed if at least 25 of the 30 questions have been answered correctly. During the examination, candidates may consult the texts of regulations on dangerous goods.

8.2.3.5.2 Specialization course on gases and chemicals

Candidates who are successful in the ADN basic training examination may apply for enrolment in a “gases” and/or “chemicals” specialization course, to be followed by an examination. The examination shall be based on the competent authority’s list of questions.

- [8.2.3.5.2.2 During the examination the candidate shall furnish proof that, in accordance with the “gases” and/or “chemicals” specialization course, he has the knowledge, understanding and capabilities required of the expert on board vessels carrying gases or chemicals, respectively.]
- [8.2.3.5.2.3 The competent authority shall prepare a list of questions for the examination, comprising the topics referred to in 8.2.2.3.3 or 8.2.2.3.4. The examination questions shall be selected from the list. The candidate shall not have advance knowledge of the questions selected. Each competent authority shall establish the arrangements for the examination on the basis of the programme described in ~~marginals 210 317 (3) or 210 318 (3)~~ 8.2.2.3.3 or 8.2.2.3.4 and the list of questions drawn up by the competent authority.]
- [8.2.3.5.2.4 In the event of multiple training courses a single examination may be organized.]
- 8.2.3.5.1.5** [The examination shall be written.]

The candidate is to be asked 30 multiple-choice questions and one substantive question. The examination shall last a total of 120 minutes, of which 60 minutes for the multiple-choice questions and 60 minutes for the substantive question.

The examination shall be marked out of a total of 60, of which 30 marks will go to the multiple-choice questions (one mark per question) and 30 to the substantive question (the distribution of marks is left to the appreciation of the competent authority). A total of 44 marks must be achieved to pass. However, not less than 20 marks must be obtained in each subject. If the candidate obtains 44 but does not achieve 20 in one subject, the subject in question may be set in a resit.

The texts of regulations and technical literature are permitted during the examination.

Each competent authority shall determine the conditions of the examination on the basis of the programme described in marginal 210 317 (3) or 210 318 (3) and the competent authority's list of questions.

8.2.3.6 ADN specialized knowledge certificate

The issue and renewal of the ADN specialized knowledge certificate conforming to 8.6.2, ~~model No. 3 of Annex B.1, Appendix 1, or model No. 3 of Annex B.2, Appendix 1~~, shall be the responsibility of the competent authority.

Certificates shall be issued to:

- candidates who have attended a basic training course and have passed the ADN examination;
- candidates who have taken part in a refresher or advanced training course.

The validity of the “gases” and/or “chemicals” specialized training certificate shall be brought into line with the validity of the basic training certificate.

If the training was not completed before the expiry of the period of validity of the certificate, a new certificate shall not be issued until the candidate has completed a further initial basic training course and passed an ADN examination or an examination referred to in ~~6.5.2~~ 8.2.3.5 above.

8.3 Miscellaneous requirements to be complied with by the crew

~~210 327~~ 8.3.1 Persons authorized on board

~~(+)~~ **8.3.1.1** Only the following persons are authorized to be on board:

- (a) members of the crew;
- (b) persons who, although not being members of the crew, normally live on board; and
- (c) persons who are on board for official reasons.

[8.3.1.2 The persons referred to in 8.3.1 (b) are not authorized to remain in the protected area of dry cargo vessels or in the cargo area of tank vessels except for short periods.]

8.3.2 Portable lamps

[On board dry cargo vessels, the only portable lamps permitted in the protected area are lamps having their own source of power.

On board tank vessels, the only portable lamps permitted in the cargo area are lamps having their own source of power.

They shall be of the “certified safe type.”]

8.3.3 Admittance on board

No unauthorized person shall be permitted on board. This prohibition shall be displayed on notice boards at appropriate places.

8.3.4 Prohibition on smoking, fire and naked light

Smoking on board the vessel is prohibited. This prohibition shall be displayed on notice boards at appropriate places.

This prohibition does not apply to the accommodation or the wheelhouse provided their windows, doors, skylights and hatches are closed.

8.3.5 Risk of sparking

Work liable to cause sparking is prohibited in the cargo area of tank vessels. This provision does not apply to mooring work.

8.4 reserved

8.5 reserved

8.6 Documents

8.6.1 Certificate of approval

8.6.1.1 Model for a certificate of approval for dry cargo vessels

Competent authority:
Space reserved for the emblem and name of the State

Certificate of approval No.:

1. Name of vessel
2. Official number
3. Type of vessel
4. Additional requirements: vessel referred to in 7.1.2.19.1¹
vessel referred to in 7.2.2.19.3¹
The vessel complies with the additional rules of construction referred to in 9.1.0.80 to 9.1.0.95 for double hull vessels¹
The vessel complies with the additional rules of construction referred to in 9.2.0.80 to 9.2.0.95 for double hull vessels¹
5. Permitted derogations:
6. The validity of this certificate of approval expires on (date)
7. The previous certificate of approval No. was issued on
by (competent authority)
8. The vessel is approved for the carriage of dangerous goods following:
- inspection on¹ (date)
- certification by a recognized classification society¹
Name of the classification society¹ (date)
9. Subject to permitted equivalences:¹
10. Subject to special authorizations:¹
11. Issued at: on
(place) (date)
12. (Stamp)
(competent authority)
.....
(signature)

¹ Delete as appropriate

2	
Extension of the validity of the certificate of approval	
13.	The validity of this certificate is extended under of ADN until (date)
14. on (place) (date)
15.	(Stamp) (competent authority)
 (signature)

8.6.1.2 ADN section of the model single certificate for the provisional inspection certificate and the provisional certificate of approval

2	
9. Carriage of dangerous goods	
9.1	Type of vessel:
9.2	Additional requirements: vessel subject to 7.1.2.19.1 ¹ vessel subject to 7.2.2.19.3 ¹ The vessel complies with the additional requirements of 9.1.0.80 to 9.1.0.95 for double hull vessels ¹ The vessel complies with the additional requirements of 9.2.0.80. to 9.2.0.95 for double hull vessels ¹
9.3	Permitted derogations:
<hr style="width: 20%; margin-left: 0;"/> ¹ Delete as appropriate.	

8.6.1.3 Model for a certificate of approval for tank vessels

Competent authority:

Space reserved for the emblem and name of the State

Certificate of approval No.:

according to Annex B 2, marginal 210-282 ADN

1. Name of vessel

2. Official number

3. Type of vessel

4. Type of tank vessel

- | | | | |
|------|----------------------|----|--|
| 6-5. | Types of cargo tanks | 1. | Pressure cargo tanks ^{1 2} |
| | | 2. | Closed cargo tanks ^{1 2} |
| | | 3. | Open cargo tanks with flame arresters ^{1 2} |
| | | 4. | Open cargo tanks ^{1 2} |

- | | | | |
|------|----------------------|----|---|
| 5-6. | Types of cargo tanks | 1. | Independent cargo tanks ^{1 2} |
| | | 2. | Integral cargo tanks ^{1 2} |
| | | 3. | Cargo tank wall distinct from the hull ^{1 2} |

7. Opening pressure of high-velocity vent valves/safety valves k/Pa^{1 2}

8. Additional equipment:

- Sampling device
 - closed yes/no^{1 2}
 - partly closed yes/no^{1 2}
 - sampling opening yes/no^{1 2}
- Water-spray system yes/no^{1 2}
- Cargo heating system:
 - possibility of cargo heating from shore yes/no^{1 2}
 - cargo heating installation on board yes/no^{1 2}
- Cargo refrigeration system yes/no^{1 2}
- Cargo pump-room below deck yes/no^{1 2}
- [• Pressure relief device yes/no^{1 2} in
- Gas supply/return line according to
 piping and installation heated yes/no^{1 2}]

9. Electrical equipment:

- Temperature class:
- Explosion group:

10. Loading rate: m³/h
 [see loading instructions]

¹ Delete as appropriate.

² If the tanks are not all of the same type, see page 3.

11. Permitted relative density:
12. ~~Permitted derogations:~~[Additional observations]
.....
13. The validity of this certificate of approval expires on (date)
14. The previous certificate of approval No. was issued on
by (competent authority)
15. The vessel is approved for the carriage of dangerous goods listed in the attestation
attached to this certificate following:
- inspection on¹ (date).....
- certification by a recognized classification society¹
- Name of the classification society¹..... (date)
16. Subjected to permitted equivalences:¹
.....
.....
17. Subject to special authorizations:¹
.....
.....
18. Issued at: on
(place) (date)
19. (Stamp)
(competent authority)
.....
(signature)

¹ Delete as appropriate

Extension of the validity of the certificate of approval

20. The validity of this certificate is extended under ~~marginal 210-282 (4) of Annex B.2~~
of ADN

Until
(date)

21. on
(place) (date)

22. (Stamp)
(competent authority)

.....
(signature)

8.6.1.4 ADN section of the model single certificate for the provisional inspection certificate and the provisional certificate of approval

		1
Competent authority:		
Space reserved for the emblem and name of the State		
Provisional certificate of approval No:		
according to Annex B.2, marginal 210 283, ADN		
1.	Name of vessel	
2.	Official number	
3.	Type of vessel	
4.	Type of tank vessel	
5.	Types of cargo tanks	
	1. Independent cargo tanks	1 ²
	2. Integral cargo tanks	1 ²
	3. Cargo tank wall distinct from the hull	1 ²
6.	Types of cargo tanks	
	1. Pressure cargo tanks	1 ²
	2. Closed cargo tanks	1 ²
	3. Open cargo tanks with flame arresters	1 ²
	4. Open cargo tanks	1 ²
7.	Opening pressure of high-velocity vent valves/safety valves kPa	1 ²
8.	Additional equipment:	
	• Sampling device	
	closed	yes/no ¹²
	partly closed	yes/no ¹²
	sampling opening	yes/no ¹²
	• Water-spray system	yes/no ¹²
	• Cargo heating system:	
	possibility of cargo heating from shore	yes/no ¹²
	cargo heating installation on board	yes/no ¹²
	• cargo refrigeration system	yes/no ¹²
	• cargo pump-room below deck	yes/no ¹²
9.	Electrical equipment:	
	• Temperature class:	
	• Explosion group:	
10.	Loading rate	m ³ /h
11.	Permitted relative density:	
12.	Permitted derogation	
	
	
¹ Delete as appropriate. ² If the tanks are not all of the same type, see page 34.		

13.	The provisional certificate of approval is valid ¹
13.1	until
13.2	for a single journey from to
14.	Issued at on
	(place) (date)
15.	(Stamp)
	(competent authority)

	(signature)
<hr/> ¹ Delete as appropriate.	

NOTE: *This model provisional certificate of approval may be replaced by a single certificate model combining a provisional certificate of inspection and the provisional certificate of approval, provided that this single certificate model contains the same particulars as the model below and is approved by the competent authorities.*

APPENDIX 1
Model 3

**8.6.2. Certificate of special knowledge of ADN according to
marginals ~~10 315, 210 315, 210 317 or 210 318~~
8.2.1.2 (format A6, Colour: orange),
8.2.1.4 or 8.2.1.5**

(Format: A6, Colour: orange)

(Space reserved for the emblem of State,
competent authority)

ADN certificate

of special knowledge of ADN

No. of certificate:

Name
First name(s):

Born on:

Nationality:

Signature of holder:

The holder of this certificate has special knowledge
of ADN

The certificate is valid for special knowledge of
ADN according to ~~marginals 10-315/210-315,~~
~~210-317, 210-318*~~

8.2.1.2 (dry cargo vessels)*

8.2.1.2 (tanks vessels)*

8.2.1.4*

8.2.1.5*

until:

Issued by:

Date:

(Stamp)

Signature:

* Delete as appropriate.

(Recto)

(Verso)

APPENDIX 2

8.6.3

1			
Checklist ADN (Marginal 210-410)			
Concerning the observance of safety provisions and the implementation of the necessary measures for loading/unloading			
- Particulars of vessel			
..... (name of vessel)		No. (official number)	
..... (vessel type)			
- Particulars of loading or unloading operations			
..... (shore loading or unloading installation)	 (place)	
..... (date)	 (time)	
- Particulars of the cargo			
Quantity m ³	Name of product	Identification number	Class/ item number
.....
.....
.....
- Particulars of last cargo*			
Name of product		Identification number	Class/ item number
.....	
.....	
.....	

* To be filled in only if vessel is to be loaded.

2							
Loading rate (not to be filled in if vessel is to be loaded with gas)							
Name of substance	Cargo tank number	agreed rate of loading/unloading					
		start		half way		end	
		rate m ³ /h	quantity m ³	rate m ³ /h	quantity m ³	rate m ³ /h	quantity m ³
.....
.....
.....

Will the cargo piping be drained after loading or unloading by stripping or by blowing residual quantities to the shore installation/to the vessel?*

by blowing*
by stripping*

If drained by blowing, how?

.....

(e.g. air, inert gas, sleeve)

..... kPa
(permissible maximum pressure in the cargo tank)

Questions to the master and the person in charge at the loading/unloading place

Loading/unloading may only be started after all questions on the checklist have been checked off by "X", i.e. answered with YES and the list has been signed by both persons.

Non-applicable questions have to be deleted.

If not all questions can be answered with YES, loading/unloading is only allowed with consent of the competent authority.

* Delete as appropriate.

	vessel	³ loading/ unloading place
1. Is the vessel permitted to carry this cargo?	O*	O*
2. Did the steersman receive the instructions in writing referred to in marginal 210-385 from the consignor?	O*	O*
3. Is the vessel well moored in view of local circumstances?	O	-[?]
4. Have suitable means been provided at the fore and at the aft of the vessel, for boarding or leaving, including in cases of emergency?	O	O
5. Are the escape routes and the loading/unloading place adequately lighted?	O	O
6. Vessel/shore connection		
6.1 Are the cargo hoses between vessel and shore in satisfactory condition?	-[?]	O
Are these hoses correctly connected?	-[?]	O
6.2 Are all the connecting flanges fitted with suitable gaskets?	-[?]	O
6.3 Are all the connecting bolts fitted and tightened?	O	O
6.4 Are the shoreside loading arms free to move in all directions and do the hoses have enough room for easy movement?	-[?]	O
7. Are all flanges of the connections of the pipes for loading and unloading and of the vapour pipe not in use, correctly blanked off?	O	O
8. Are suitable means of collecting leakages placed under the pipe connections which are in use?	O	O
9. Are the movable connecting pieces between the ballast and bilge piping on the one hand and the pipes for loading and unloading on the other hand disconnected?	O	-[?]
10. Is continuous and suitable supervision of loading/unloading ensured for the whole period of the operation?	O	O
11. Is communication between vessel and shore ensured?	O	O

* To be filled in only if vessel is to be loaded.

		vessel	loading/ unloading place 4
12.1	For the loading of the vessel, is the vapour pipe, where required, or if it exists, connected with the shore gas return line?	O	O
12.2	Is it ensured that the shore installation is such that the pressure at the connecting point cannot exceed the opening pressure of the high-velocity vent valves?	-	O*
[12.3	When anti-explosion protection is required in accordance with [...] does the shore installation ensure that its gas return line or gas exchange line is such that the vessel is protected against detonations and flame fronts from the shore.	-	O]
13.	Is it known what actions are to be taken in the event of an “Emergency-stop” and an “Alarm”?	O	O
14.	Check on the most important operational requirements: <ul style="list-style-type: none"> – Are the required fire extinguishing systems and appliances operational? – Have all valves and other closing devices been checked for correct open - or closed position? – Has smoking been generally prohibited? – Are the flame-operated heating, cooking and cooling applications on board turned off? – Are the liquefied gas installations shut off at the main check valve? – Is the voltage cut off from the radar installations? – Is all electrical equipment marked red switched off? – Are all windows and doors closed? 	O O O O O O O O	O O O -[?] -[?] -[?] -[?] -[?]
15.1	Has the starting working pressure of the vessel's cargo discharge pump been adjusted to the permissible working pressure of the shore installation?	O	-[?]
15.2	Has the starting working pressure of the shore pump been adjusted to the permissible working pressure of the on board installation?	-	O
16.	Is the liquid level alarm-installation operational?	O	-[?]
17.	Is the level control device activating the overflow prevention system plugged in, in working order and tested?	O	O

		vessel	5 loading/ unloading place
18.	To be filled in only in the case of loading or unloading of substances for the carriage of which a vessel of the closed type or a vessel of the open type with flame arrester is required. Are the cargo tank hatches and cargo tank inspection, gauging and sampling openings closed or protected by flame arresters in good condition?	O	-[?]
<p>Checked, filled in and signed</p> <p>for the vessel: _____ for the installation of loading and unloading</p> <p>.....</p> <p>name (in capital letters) name (in capital letters)</p> <p>.....</p> <p>(signature) (signature)</p>			

Explanation

Question 3

“Well moored” means that the vessel is fastened to the pier or the cargo transfer station in such a way that, without intervention of a third person, movements of the vessel in any direction that could hamper the operation of the cargo transfer gear will be prevented. Established or predictable variations of the water-level at that location and special factors have to be taken into account.

Question 4

It must be possible to board or escape from the vessel at any time. If there is none or only one protected escape route available at the shoreside for a quick escape from the vessel in case of emergency, a suitable means of escape has to be provided on the vessel side (e.g. a lowered dinghy).

Question 6

A valid inspection certificate for the loading/unloading hoses must be available on board. The material of the hoses must be able to withstand the expected loads and be suitable for cargo transfer of the respective substances. The term cargo hoses includes hoses as well as the

shoreside loading/discharging arms. The cargo transfer hoses between vessel and shore must be placed so that they cannot be damaged by variations of the water-level, passing vessels and/or loading/unloading operations. All flange connections are to be fitted with appropriate gaskets and sufficient bolt connections in order to exclude the possibility of leakage.

Question 10

Loading/unloading must be supervised on board and ashore so that dangers which may occur in the vicinity of cargo hoses can be recognized immediately.

Question 11

For a safe loading/unloading operation good communications between vessel and shore are required. For this purpose telephone and radio equipment may be used only if of an explosion protected type and located within reach of the supervisor.

Question 13

Before the start of the loading/unloading operation the representative of the shore installation and the master must agree on the applicable procedure. The specific properties of the substances to be loaded/unloaded have to be taken into account.

APPENDIX 3
Model 1

8.6.4 Discharge of residual quantities and stripping systems

8.6.4.1 DEVICE FOR THE DISCHARGE OF RESIDUAL QUANTITIES

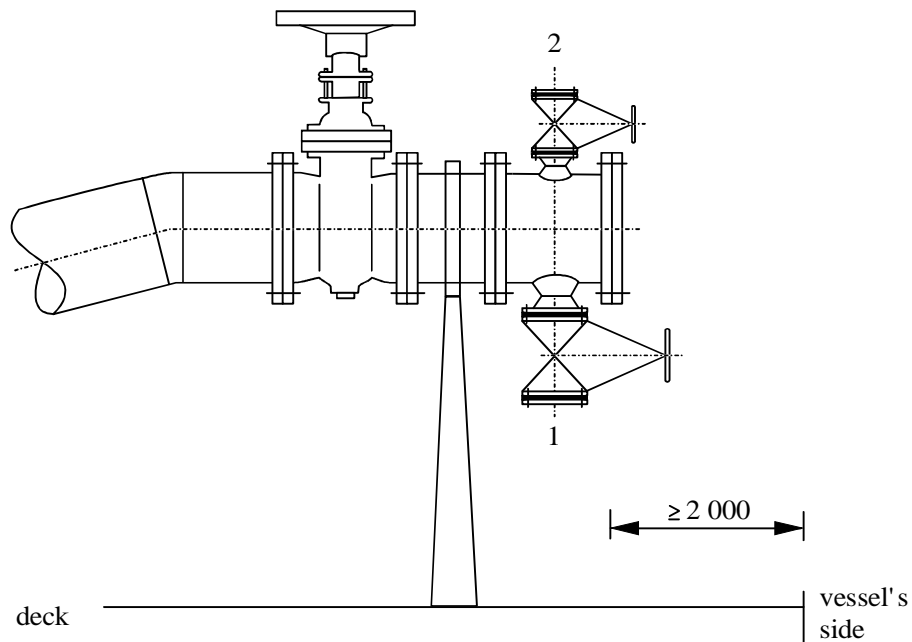

1. Connection for the discharge of residual quantities
~~Connection conforming to CEFIC~~
2. Connection of the shore installation intended for blowing residual quantities to the short installation by means of a gas
~~Connection conforming to CEFIC~~

8.6.4.2 Test of the stripping system

- (1)8.6.4.2.1 Before the start of the test, the cargo tanks and their piping shall be clean. The cargo tanks shall be safe for entry.
- (2)8.6.4.2.2 During the test, the trim and list of the vessel shall not exceed normal operating values.
- (3)8.6.4.2.3 During the test, a back pressure of not less than 300 kPa (3 bar) shall be maintained at the device for discharge of residual quantities fitted on the pipe for unloading.
- (4)8.6.4.2.4 The test shall comprise :
- (a) The filling of the cargo tank with water until the suction intake inside the tank is submerged;
 - (b) The pumping out of the water and the emptying of the cargo tank and the corresponding piping by means of the tank's stripping system;
 - (c) The collection of the remaining water at the following points:
 - The cargo tank suction intake;
 - The bottom of the cargo tank where water has collected;
 - The lowest point drain of the cargo pump;
 - At all the lowest points of the piping associated with the cargo tank up to the device for the discharge of residual quantities.
- (5)8.6.4.2.5 The quantity of water collected as described in paragraph (4)(c) 8.6.4.2.4 (c) shall be measured precisely and noted in the test certificate [referred to in 8.6.4.3].
- (6)8.6.4.2.6 The competent authority or the recognized classification society shall set out all the operations required for the test in the test certificate.

This certificate shall include at least the following data:

- trim of the vessel during the test;
- [list] of the vessel during the test;
- tank unloading order;
- back pressure at the device for the discharge of residual quantities;
- residual quantity per tank;
- residual quantity per piping system;
- duration of the stripping operation;
- cargo tank plan, duly completed.

