



Economic and Social Council

Distr.: General
24 July 2015

Original: English

Economic Commission for Europe

Administrative Committee for the TIR Convention, 1975

Sixty-first session

Geneva, 8 October 2015

Item 6 (a) of the provisional agenda

Revision of the Convention:

**Accepted amendment proposals to the
Convention pending formal adoption**

Accepted amendment proposals to the Convention pending formal adoption

Note by the secretariat

I. Mandate and background

1. The Committee accepted the proposal to amend Article 42 bis with an Explanatory Note 0.42 bis (ECE/TRANS/WP.30/AC.2/125, para. 9 and Annex I), as well as the proposal for a new design of a vehicle and container to the TIR Convention (ECE/TRANS/WP.30/AC.2/125, para. 14). The EU had informed the Committee that it had not yet concluded its internal approval procedure on the proposed amendments. Therefore, the Committee decided to postpone the formal adoption of these proposals until its current session. For ease of reference, the secretariat has consolidated the proposals into a single package, in Annex to the present document.

II. Considerations by the Committee

2. The Committee is invited to formally adopt the proposals and to provide guidance to the secretariat as to whether they can be transmitted to the depositary immediately following the current session of the Committee or as a part of a larger package of amendments, at a date to be determined by the Committee.

Annex

Legal amendments to the text of the Convention

The Administrative Committee,

Agreeing that national measures to ensure the proper use of the TIR procedure are allowed as long as they are communicated as soon as possible and, if possible, prior to their entry into force to and discussed by the TIRExB as to their conformity with the TIR Convention,

Recognizing that TIRExB is vested with the responsibility to supervise the application of the TIR convention and to facilitate the settlement of disputes between Contracting Parties, associations, insurance companies and international organizations, as per Annex 8, article 10 of the TIR Convention,

Understanding that the the word “immediately” in Article 42 bis does not provide sufficient clarity,

Has adopted the following amendment to Annex 6 of the Convention, in accordance with the provisions of Article 60 of the Convention:

Annex 6, New Explanatory Note 0.42 bis:

Add a new Explanatory Note to Article 42 bis to read

Explanatory Note to Article 42 bis:

“0.42 bis The term “immediately” in Article 42 bis is understood to mean that national measures that may affect the application of the TIR Convention and/or functioning of the TIR system, ought to be communicated in writing to the TIRExB as soon as possible and, if possible, prior to their entry into force so as to allow the TIRExB to efficiently discharge its supervisory functions and fulfil its responsibility to examine the measure as to its conformity with the TIR Convention in accordance with Article 42 bis and its Terms of Reference as laid down in Annex 8 of the TIR Convention.”

The Administrative Committee,

Recognizing that, in order that goods carried under the TIR transit procedure may travel with minimum interference “en route” and yet offer maximum safeguards to customs administrations, it is necessary that goods travel in customs secure vehicles or containers,

Understanding that vehicles and containers with a sheeted sliding roof are a new transport technique improving the effectiveness and efficiency of road transport,

Confident that the introduction of a new design of vehicles and containers with a sheeted sliding roof or sliding sheets is customs secure, and could be incorporated into Annexes 2 and 7 of the TIR convention,

Has adopted the following amendments to Annexes 2 and 7 of the Convention, in accordance with the provisions of Article 60 of the Convention:

Annex 2, Article 4, paragraph 2, (i)

For the existing text substitute(i) The sliding sheets, floor, doors and all other constituent parts of the load compartment shall be assembled either by means of devices which cannot be removed and replaced from the outside without leaving obvious traces, or by such methods as will produce a structure which cannot be modified without leaving obvious traces.

Annex 2, Article 4, paragraph 2, (iii)

For the existing text substitute

(iii) The sliding sheet guidance, sliding sheet tension devices and other movable parts shall be assembled in such a way that when closed, and Customs sealed, doors and other movable parts cannot be opened or closed from the outside without leaving obvious traces. The sliding sheet guidance, sliding sheet tension devices and other movable parts shall be assembled in such a way that it is impossible to gain access to the load compartment without leaving obvious traces once the closing devices have been secured. An example of such a system of construction is given in sketch No. 9 appended to these Regulations.

Annex 2, new Article 5

After the modified Article 4 insert

Article 5

Vehicles with a sheeted sliding roof

1. Where applicable, the provisions of Articles 1, 2, 3 and 4 of these Regulations shall apply to vehicles with a sheeted sliding roof. In addition, these vehicles shall conform to the provisions of this Article.
2. The sheeted sliding roof shall fulfil the requirements set out in (i) to (iii) below.
 - (i) The sheeted sliding roof shall be assembled either by means of devices which cannot be removed and replaced from the outside without leaving obvious traces, or by such methods as will produce a structure which cannot be modified without leaving obvious traces.
 - (ii) The sliding roof sheet shall overlap with the solid part of the roof at the front side of the load compartment, so that the roof sheet cannot be pulled over the top edge of the upper cantrail. In the length of the load compartment, at both sides, in the hem of the roof sheet, a pre-stressed steel cable shall be inserted

in such a way that it cannot be removed and re-inserted without leaving obvious traces. The roof sheet shall be secured to the sliding carriage in such a way that it cannot be removed and re-secured without leaving obvious traces.

- (iii) The sliding roof guidance, the sliding roof tension devices and other movable parts shall be assembled in such a way that when closed, and Customs sealed, doors, roof and other movable parts cannot be opened or closed from the outside without leaving obvious traces. The sliding roof guidance, sliding roof tension devices and other movable parts shall be assembled in such a way that it is impossible to gain access to the load compartment without leaving obvious traces once the closing devices have been secured.

An example of a possible system of construction is shown in sketch No.10, appended to these Regulations.

Annex 2, Sketch No. 9

For the existing Sketch No. 9 *substitute*

Sketch No. 9

EXAMPLE OF A CONSTRUCTION OF A VEHICLE WITH SLIDING SHEETS

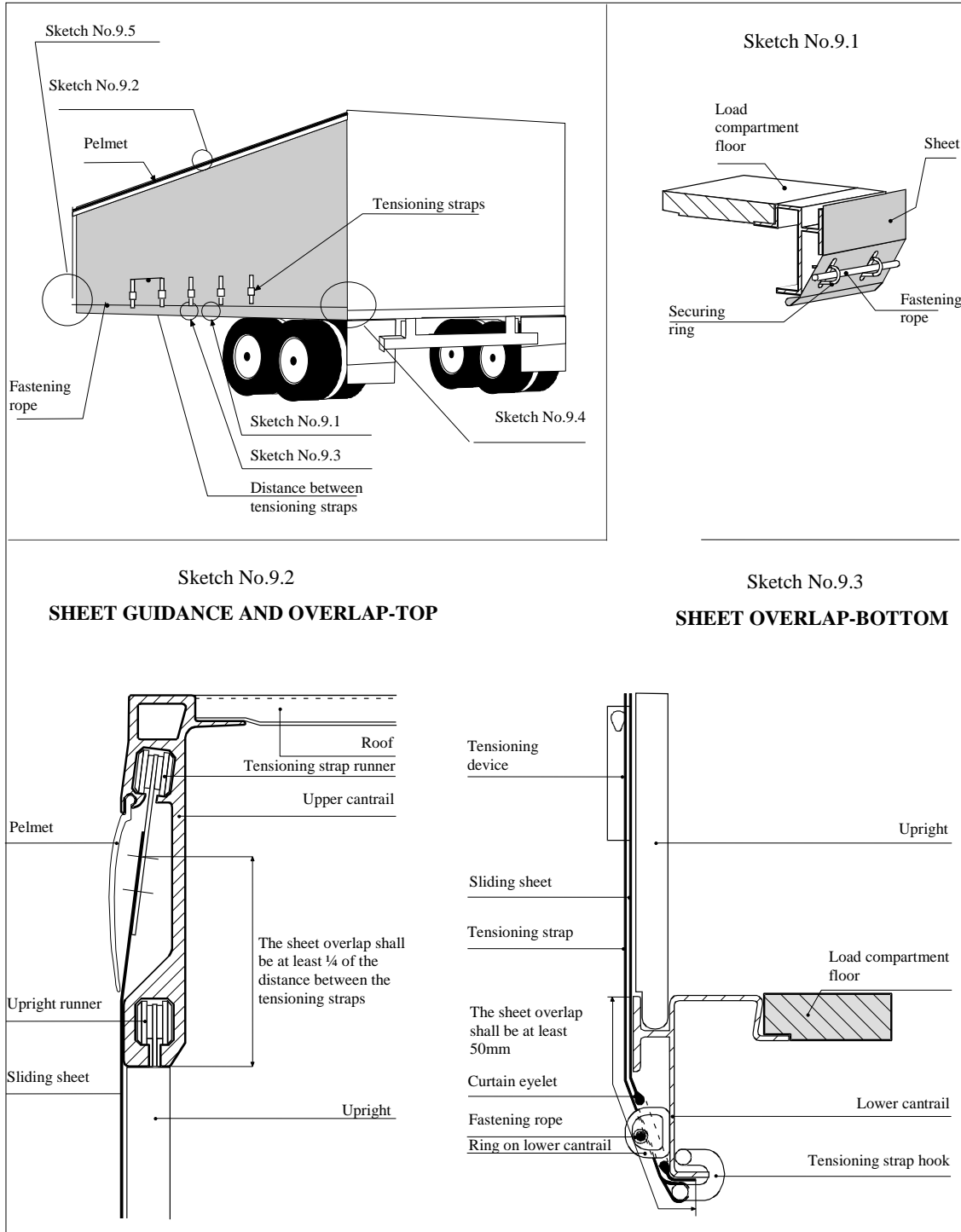

Sketch No. 9 continued

Sketch No. 9.4

To tighten the sliding sheets in the horizontal direction, a ratchet gear is used (normally at the rear end of the vehicle). This sketch shows two examples, (a) and (b), of how the ratchet or gearbox may be secured.

(a) Ratchet securing

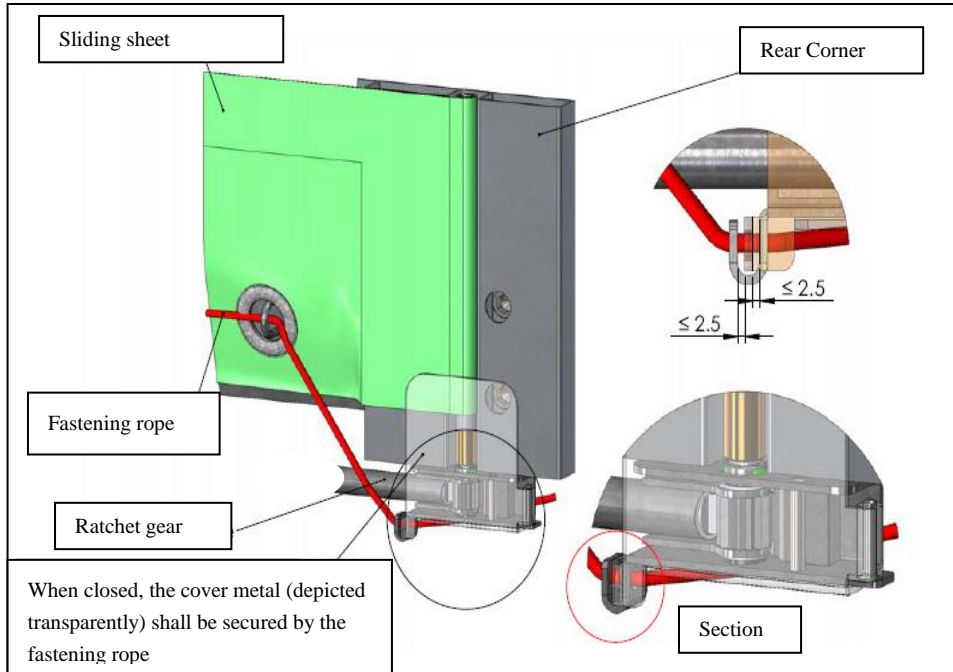

(b) Gearbox securing

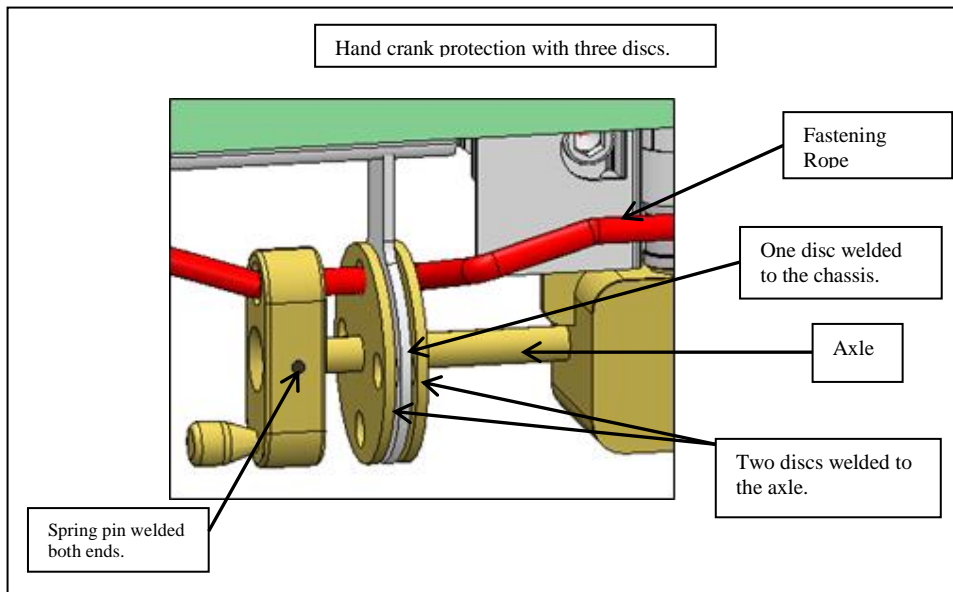

Sketch No. 9 continued

Sketch No. 9.5

To fix the sliding sheet on the other side (normally the front of the vehicle), the following systems, (a) or (b), may be used.

(a) Cover metal

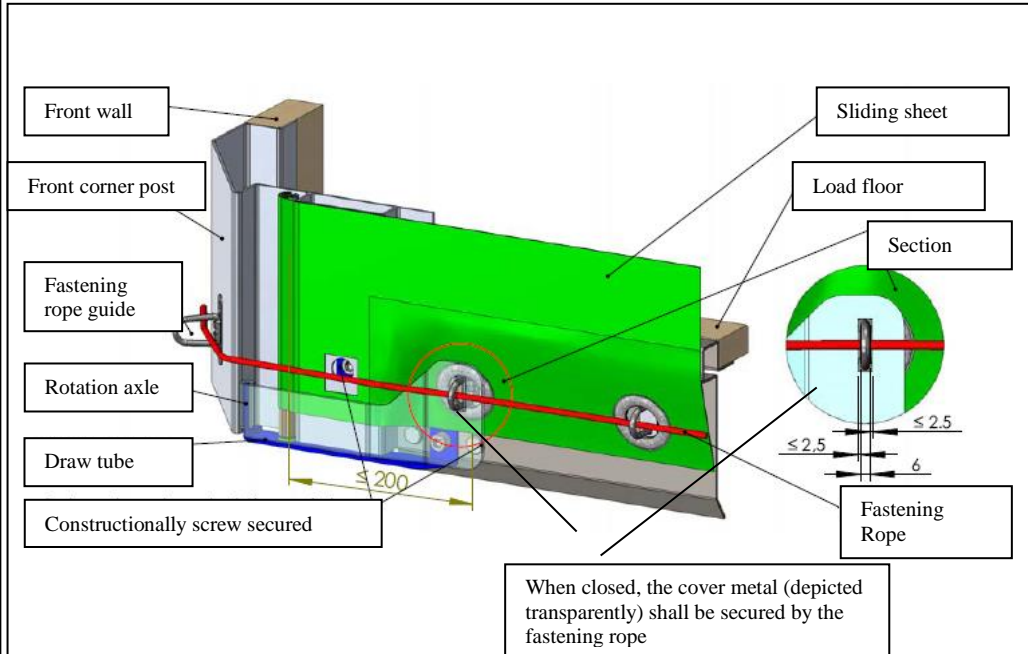

(b) Narrow oval eyelet, anti-lifting system for the tensioning tube

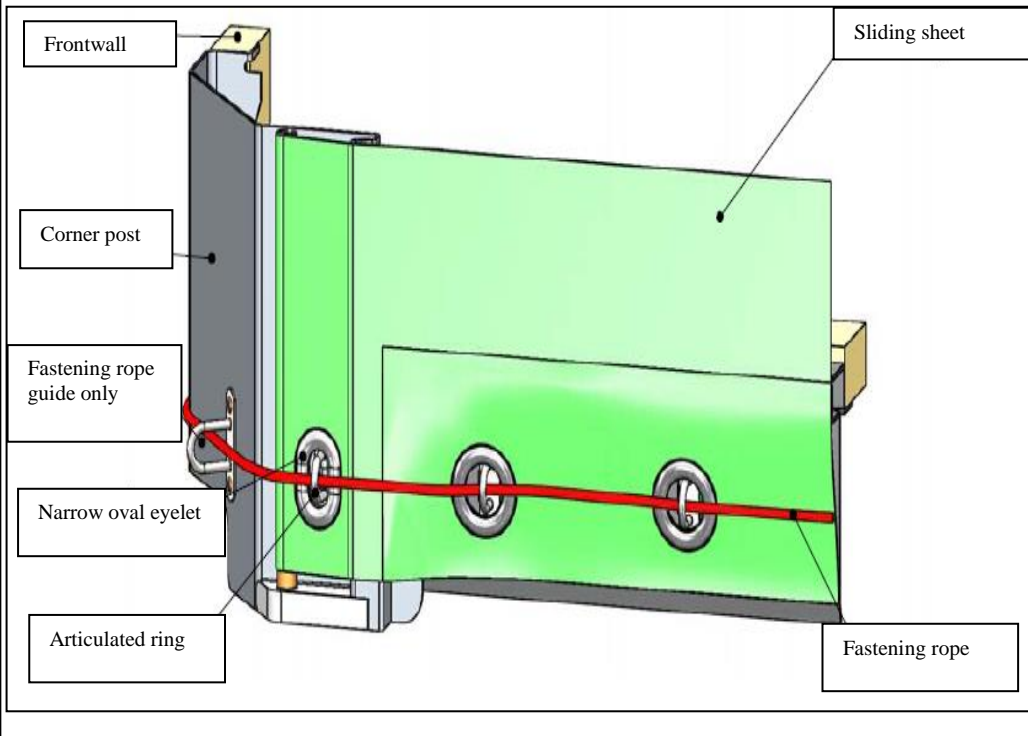

Annex 2, new Sketch No. 10

After new Sketch No. 9 insert

Sketch No. 10

EXAMPLE OF A CONSTRUCTION OF A VEHICLE WITH A SHEETED SLIDING ROOF

This sketch shows an example of a vehicle and the important requirements described in Article 5 of these Regulations.

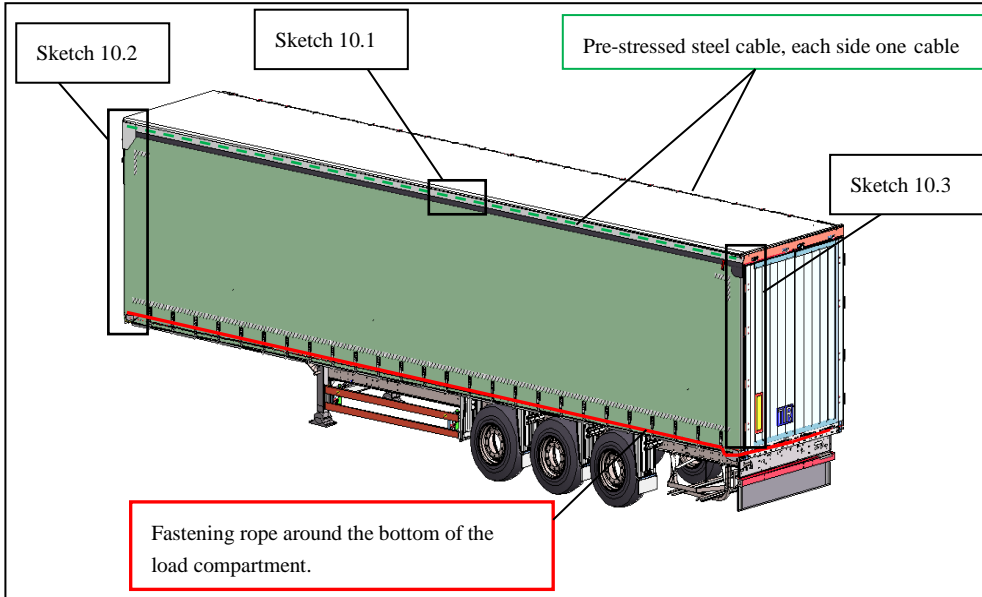

Sketch No. 10.1

Two pre-stressed steel cables, embedded in a hem, are fixed on each side of the load compartment. This pre-stressed steel cable is fixed to the front (see sketch 10.2) and rear of the body (see sketch 10.3). The tractive force as well as the connecting disc on each sliding carriage makes it impossible to lift up the hem with the pre-stressed steel cable above the upper cantrail.

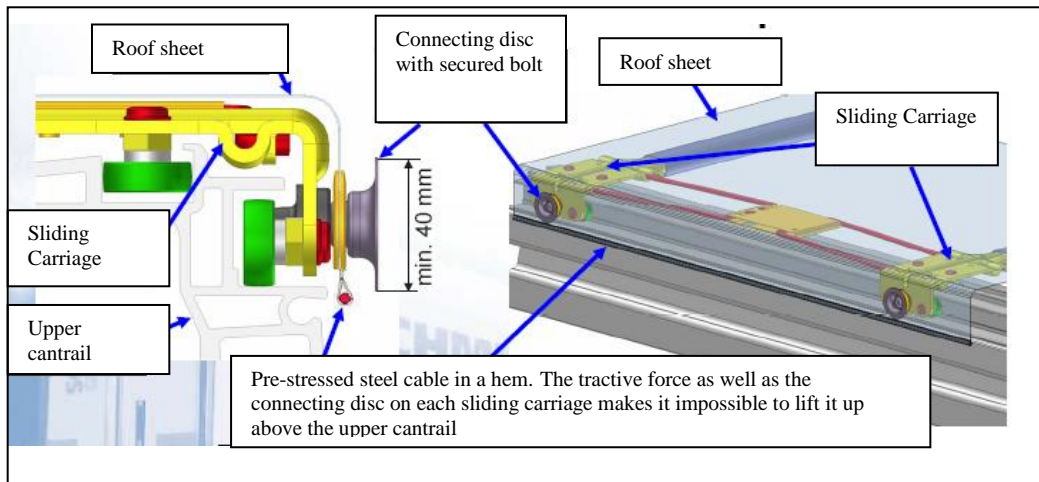

Sketch No. 10 continued

Sketch No.10.2

The sliding roof sheet shall overlap with the solid part of the roof at the front side of the load compartment, so that the roof sheet cannot be pulled over the top edge of the upper cantrail.

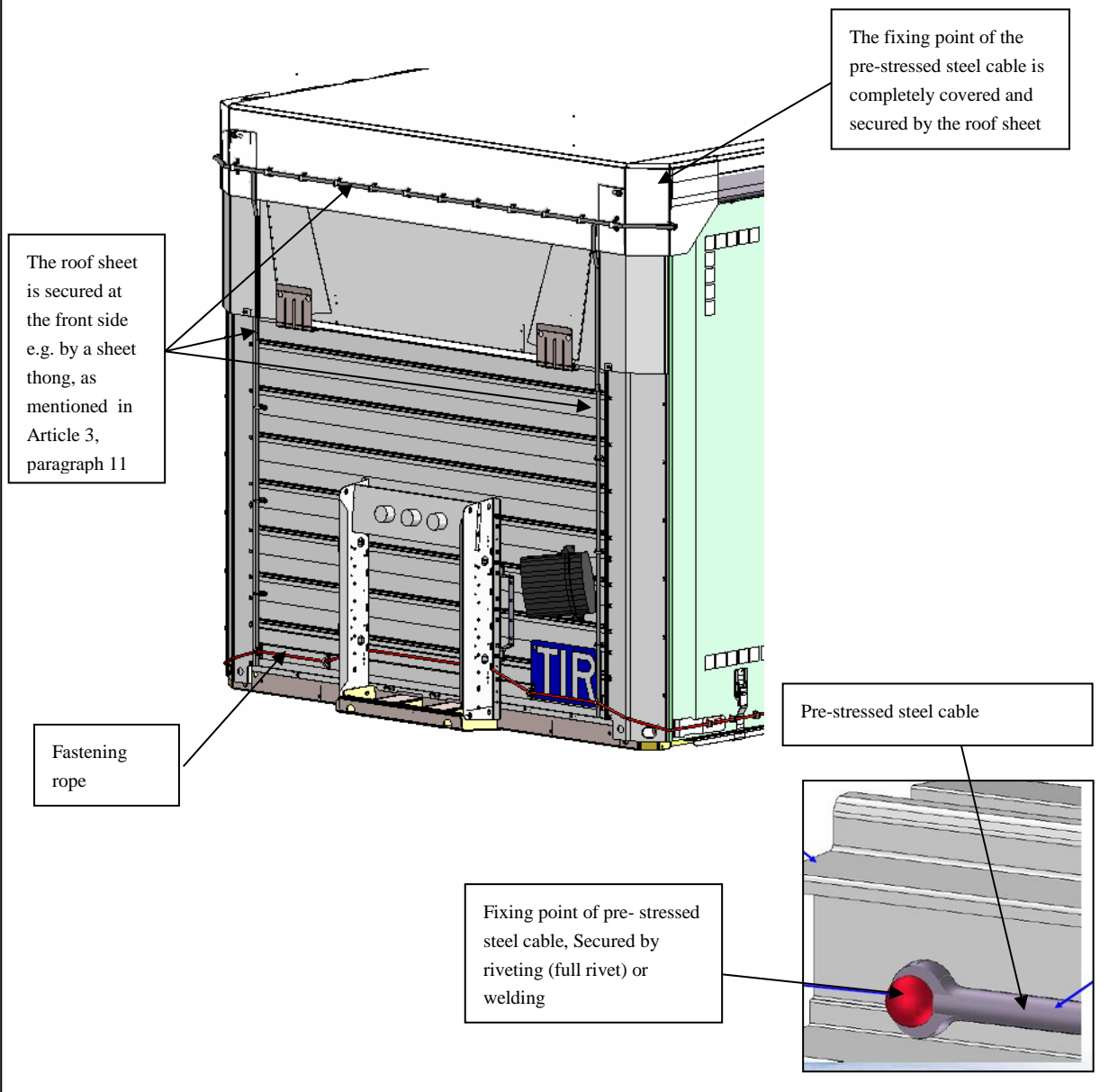

Sketch No. 10 continued

Sketch No.10.3

At the rear, a special device, such as a baffle plate, is fitted to the roof, preventing access to the load compartment, without leaving obvious traces when the doors are closed and sealed.

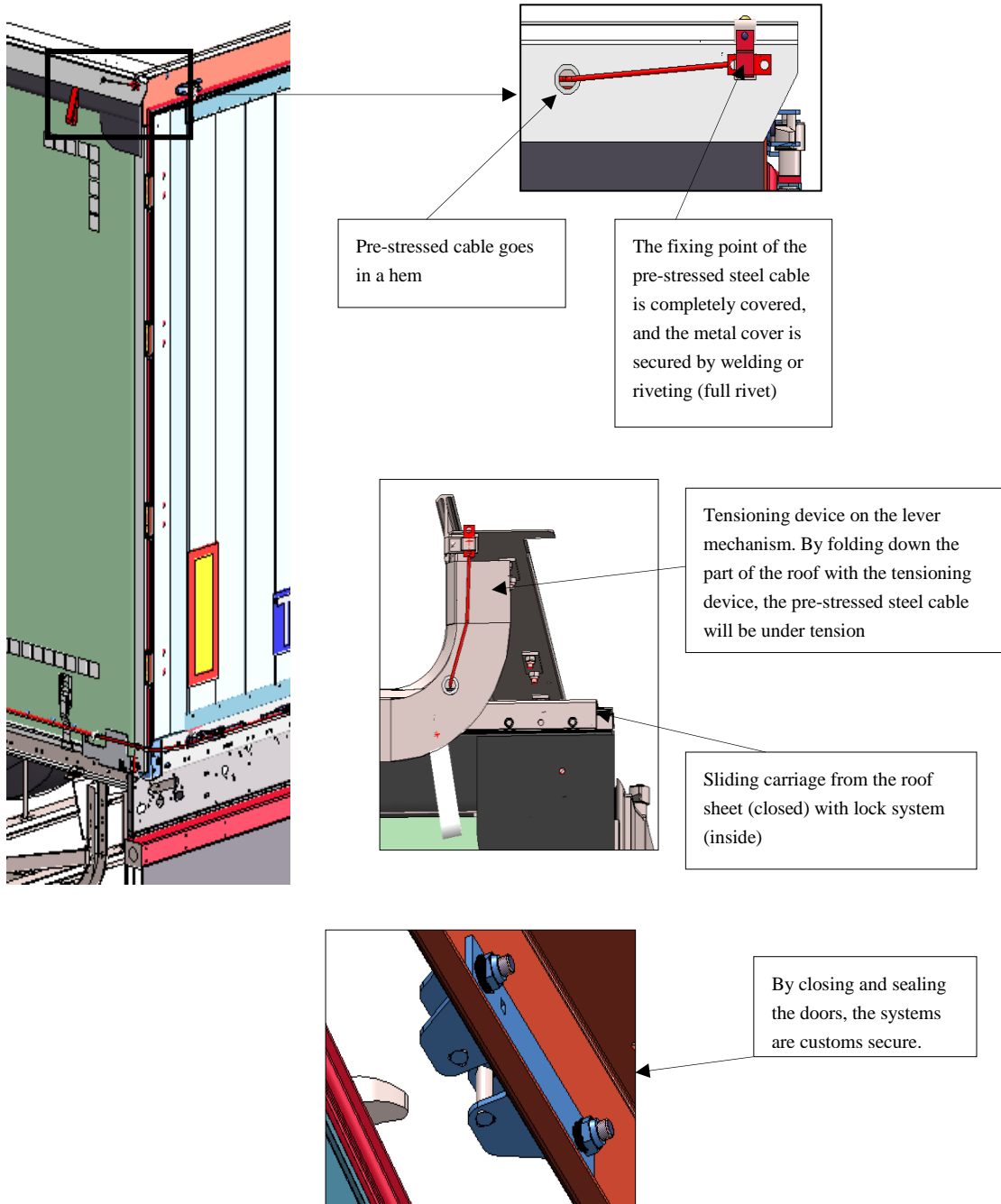

Annex 7, Part I, Article 5, paragraph 2, (i)

For the existing text *substitute*

(i) The sliding sheets, floor, doors and all other constituent parts of the container shall be assembled either by means of devices which cannot be removed and replaced from the outside without leaving obvious traces, or by such methods as will produce a structure which cannot be modified without leaving obvious traces.

Annex 7, Part I, Article 5, paragraph 2, (iii)

For the existing text *substitute*

(iii) The sliding sheet guidance, sliding sheet tension devices and other movable parts shall be assembled in such a way that when closed, and Customs sealed, doors and other movable parts cannot be opened or closed from the outside without leaving obvious traces. The sliding sheet guidance, sliding sheet tension devices and other movable parts shall be assembled in such a way that it is impossible to gain access to the container without leaving obvious traces once the closing devices has been secured. An example of such a system of construction is given in sketch No. 9 appended to these Regulations.”

Annex 7, Part I, new Article 6

After the modified Article 5 *insert*

Article 6**Containers with a sheeted sliding roof**

1. Where applicable, the provisions of Articles 1, 2, 3, 4 and 5 of these Regulations shall apply to containers with a sheeted sliding roof. In addition, these containers shall conform to the provisions of this Article.
2. The sheeted sliding roof shall fulfil the requirements set out in (i) to (iii) below.
 - (i) The sheeted sliding roof shall be assembled either by means of devices which cannot be removed and replaced from the outside without leaving obvious traces, or by such methods as will produce a structure which cannot be modified without leaving obvious traces.
 - (ii) The sliding roof sheet shall overlap with the solid part of the roof at the front side of the container, so that the roof sheet cannot be pulled over the top edge of the upper cantrail. In the length of the container, at both sides, in the hem of the roof sheet, a pre-stressed steel cable shall be inserted in such a way that it cannot be removed and re-inserted without leaving obvious traces. The roof sheet shall be secured to the sliding carriage in such a way that it cannot be removed and re-secured without leaving obvious traces.
 - (iii) The sliding roof guidance, the sliding roof tension devices and other movable parts shall be assembled in such a way that when closed, and Customs sealed, doors, roof and other movable parts cannot be opened or closed from the outside without leaving obvious traces. The sliding roof guidance, sliding roof tension devices and other movable parts shall be assembled in such a way that it is impossible to gain access to the container without leaving obvious traces once the closing devices have been secured.

An example of a possible system of construction is shown in sketch No. 10, appended to these Regulations.

Annex 7, Part I, Sketch No. 9

For the existing Sketch No. 9 substitute

Sketch No. 9

EXAMPLE OF A CONSTRUCTION OF A CONTAINER WITH SLIDING SHEETS

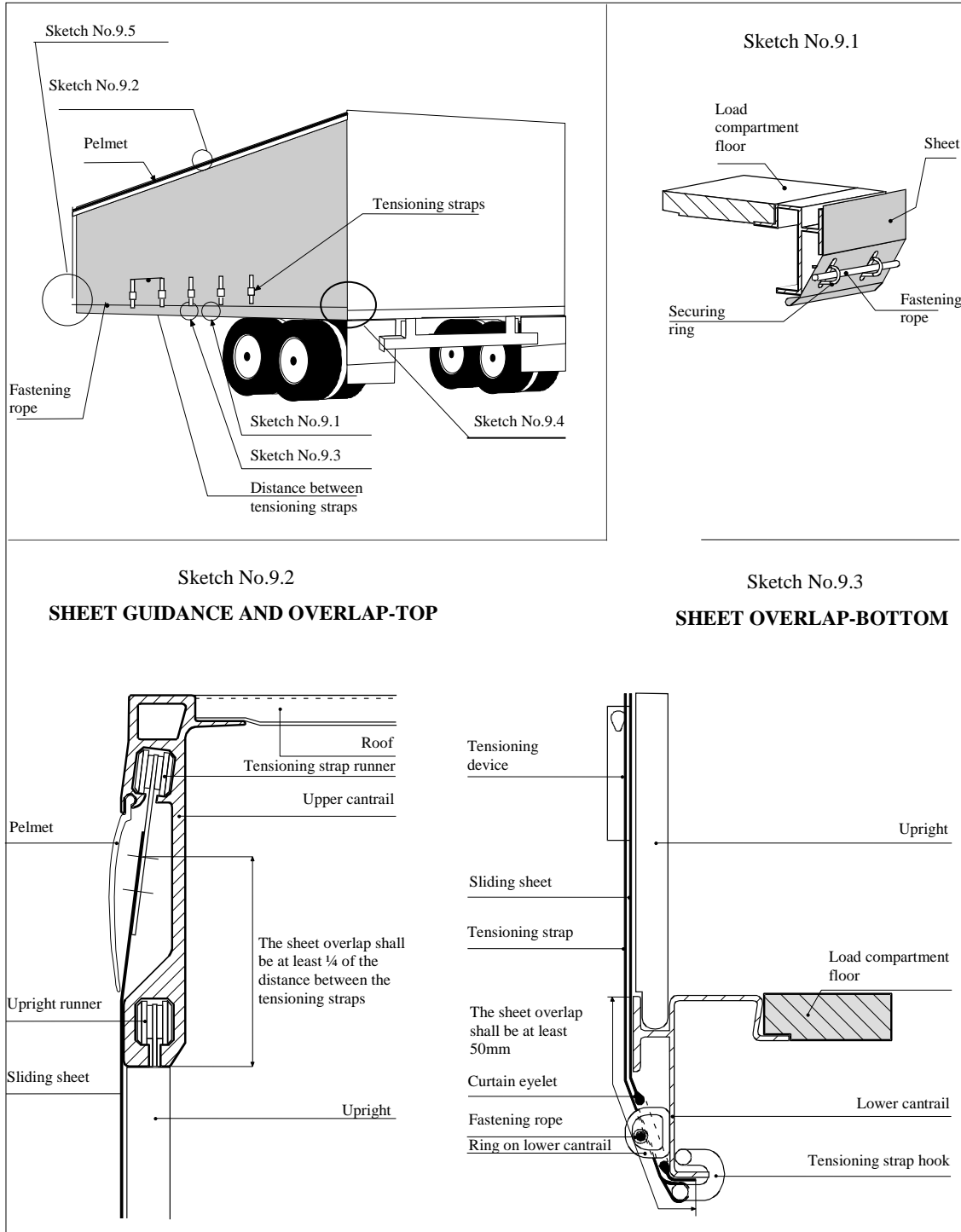

Sketch No. 9 continued

Sketch No. 9.4

To tighten the sliding sheets in the horizontal direction, a ratchet gear is used (normally at the rear end of the container). This sketch shows two examples, (a) and (b), of how the ratchet or gearbox may be secured.

(a) Ratchet securing

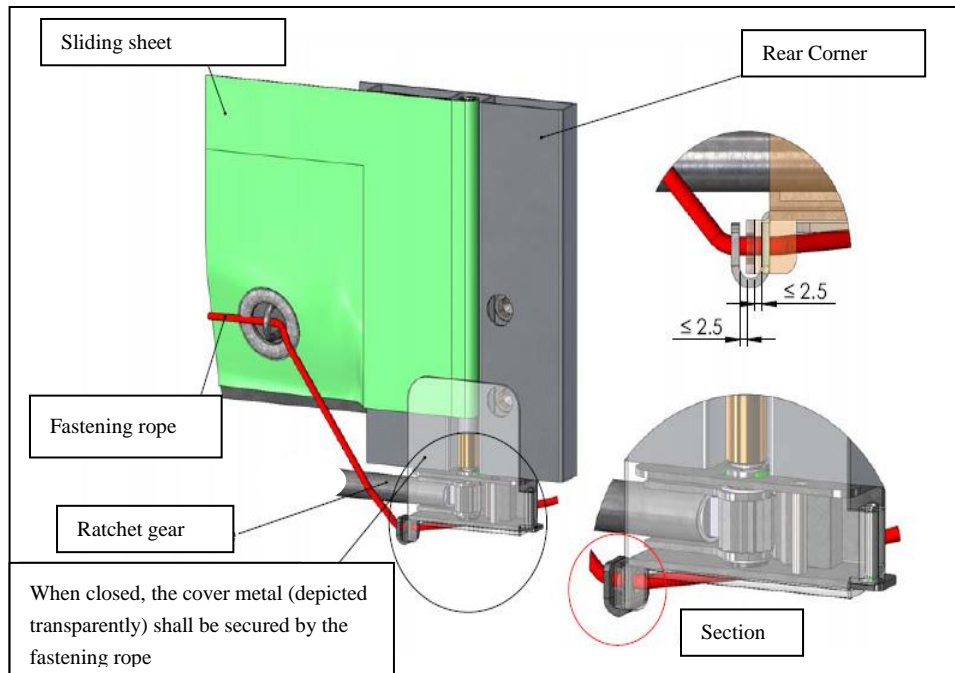

(b) Gearbox securing

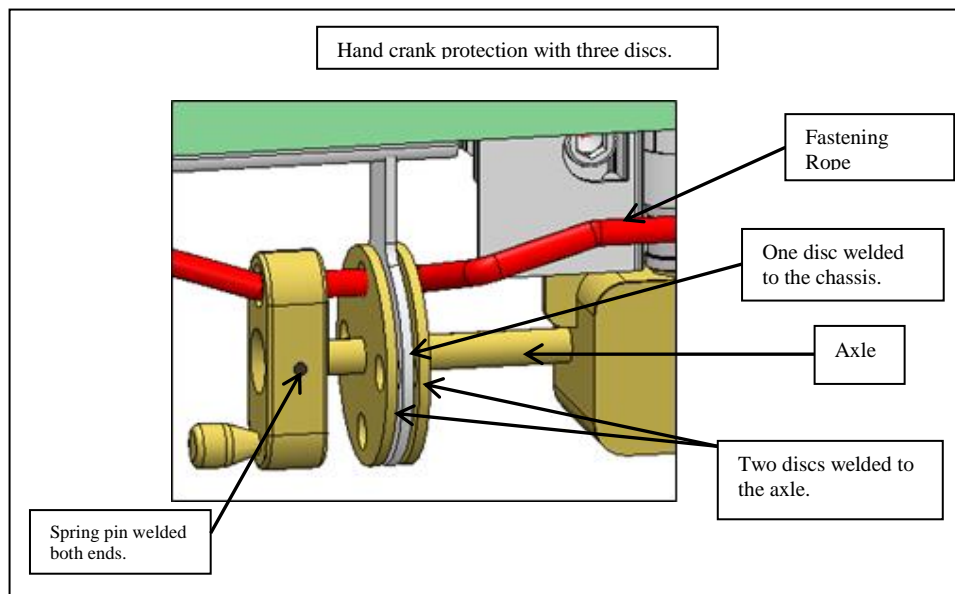

Sketch No. 9 continued

Sketch No. 9.5

To fix the sliding sheet on the other side (normally the front of the container), the following systems, (a) or (b), may be used.

(a) Cover metal

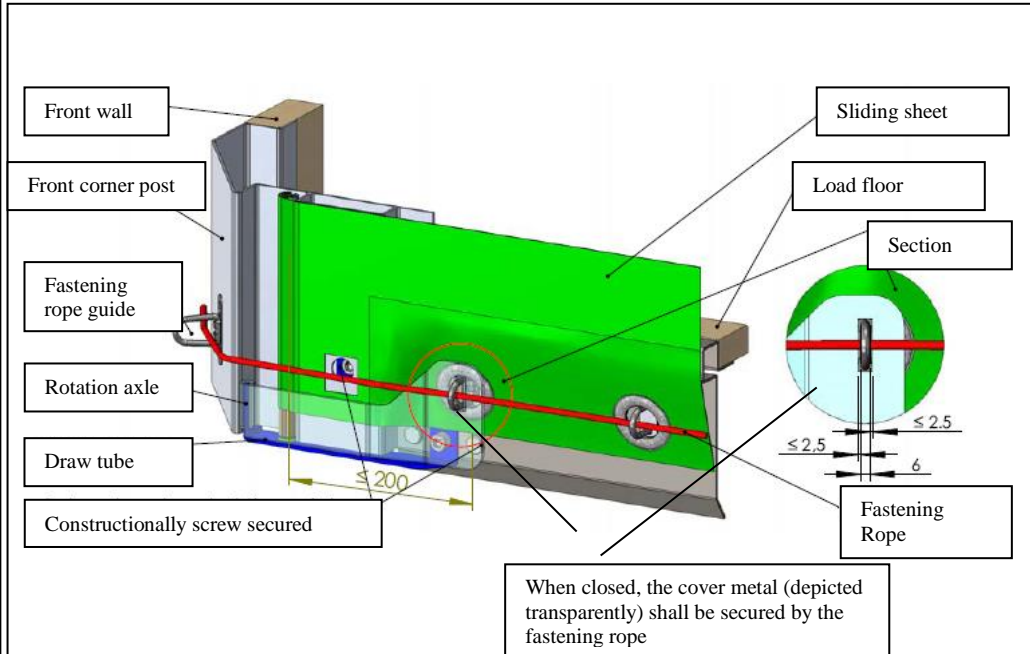

(b) Narrow oval eyelet, anti-lifting system for the tensioning tube

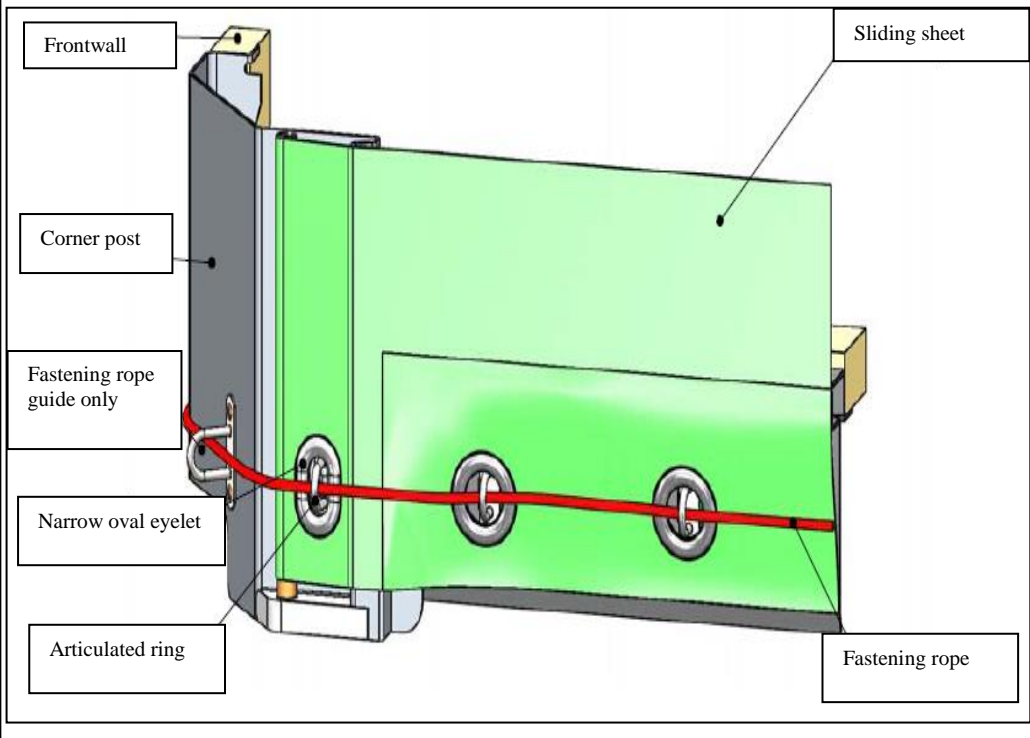

Annex 7, Part I, Sketch No. 9

After new Sketch No. 9 insert

Sketch No. 10

EXAMPLE OF A CONSTRUCTION OF A CONTAINER WITH A SHEETED SLIDING ROOF

This sketch shows an example of a container and the important requirements described in Article 6 of these Regulations.

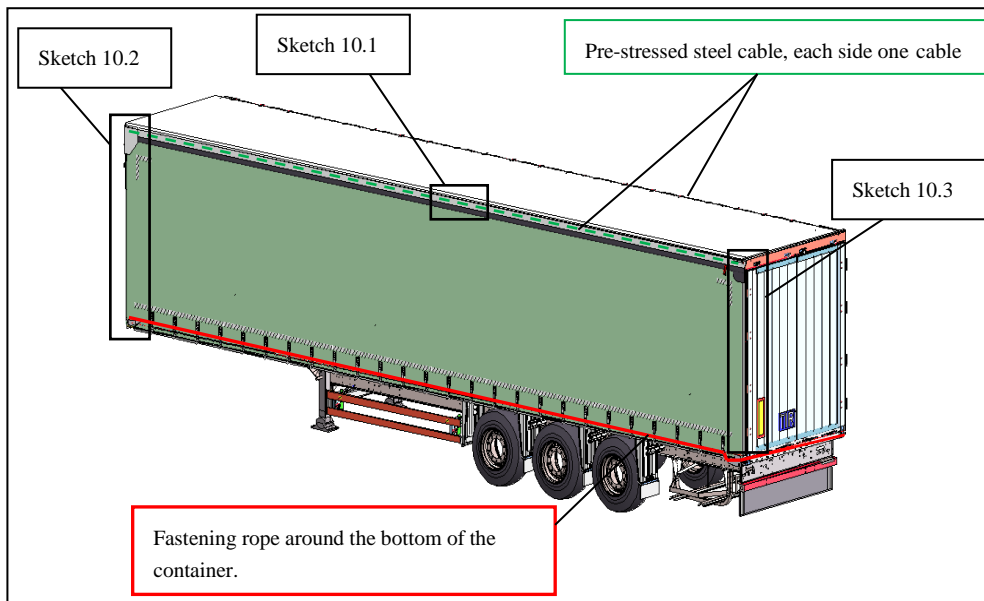

Sketch No. 10.1

Two pre-stressed steel cables, embedded in a hem, are fixed on each side of the container. This pre-stressed steel cable is fixed to the front (see sketch 10.2) and rear of the body (see sketch 10.3). The tractive force as well as the connecting disc on each sliding carriage makes it impossible to lift up the hem with the pre-stressed steel cable above the upper cantrail.

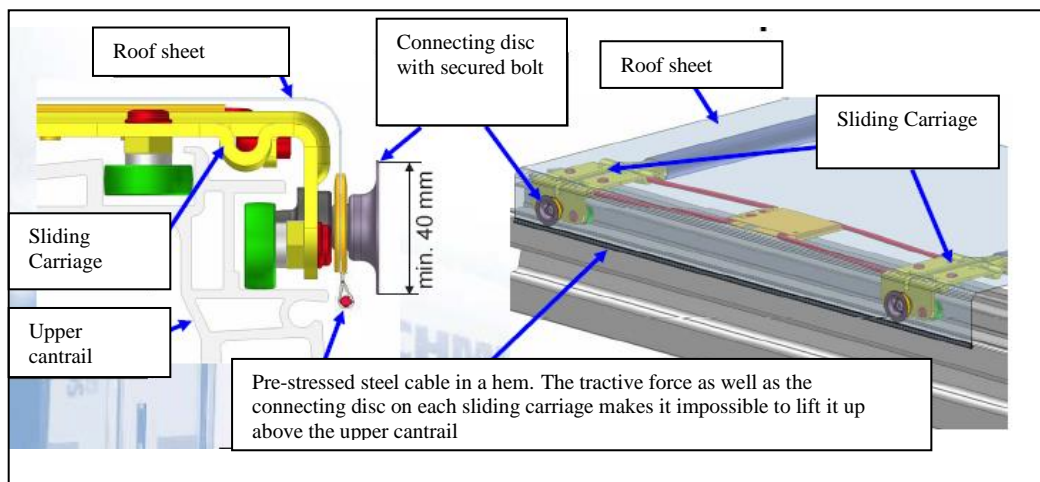

Sketch No. 10 continued

Sketch No.10.2

The sliding roof sheet shall overlap with the solid part of the roof at the front side of the container, so that the roof sheet cannot be pulled over the top edge of the upper cantrail

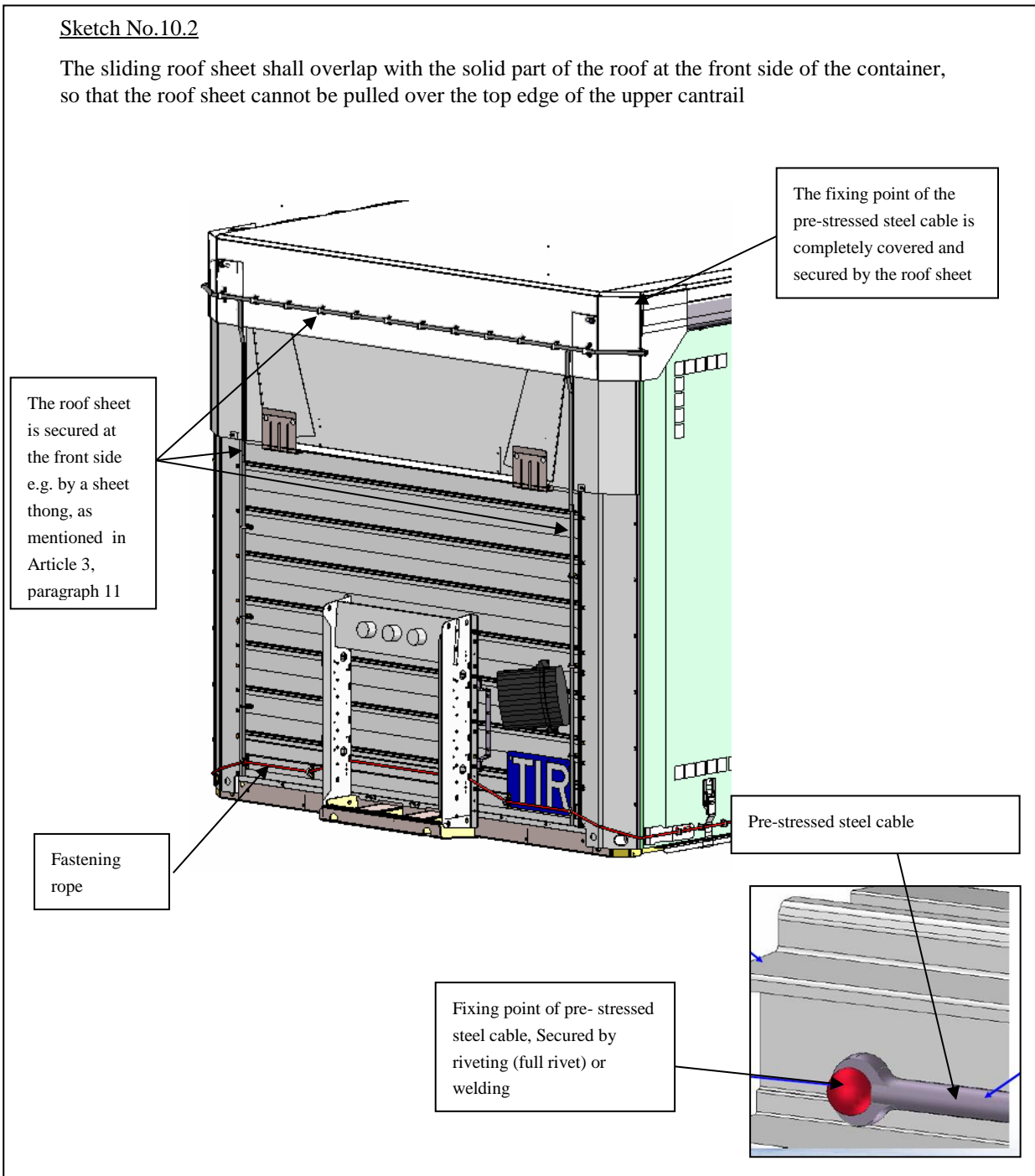

Sketch No. 10 continued

Sketch No.10.3

At the rear, a special device, such as a baffle plate, is fitted to the roof, preventing access to the container, without leaving obvious traces when the doors are closed and sealed.

