

1
2
3
4
5
6

7
8
9
10

11
12
13
14
15
16
17
18
19
20
21
22
23
24
25
26
27
28
29
30
31
32
33
34
35
36
37
38
39
40
41



UN/CEFACT

**SIMPLE, TRANSPARENT AND EFFECTIVE PROCESSES
FOR GLOBAL BUSINESS**

Business Requirements Specification (BRS)

Business Domain: Contract Management

Business Process: Electronic Agreement Negotiation

Document Identification:

Title: Electronic Agreement Template and Process

Group: Electronic Agreement Template and Process Work Group

TBG2 – Digital Papers Domain

Version: 0

Release: x

Revision 2

Date: June 30, 2006

42 **Document History**

43

Document Identifier	
Document Version	Version 0, Release x
Electronic model agreement Version	Revision 1
Document Issue Date	March 9, 2006

44

45

46 **Document Summary**

47

Document Title	Electronic Agreement Template and Process
Owner	TBG2, Electronic Agreements Working Group
Status	Draft This draft was prepared for the March 14-16th, 2006 TBG2 Work Group, TMG Work Group and UN/CEFACT Legal Group meetings

48

49

50 **Document Change History Log**

51

Date of Change	Version	Paragraph Changed	Summary of Changes

52

53

54

55
56
57

Business Requirements Specification Table of Contents

58 BUSINESS REQUIREMENTS SPECIFICATION	
59(BRS).....	1
60 BUSINESS DOMAIN: CONTRACT MANAGEMENT.....	1
61 BUSINESS PROCESS: ELECTRONIC AGREEMENT NEGOTIATION.....	1
62 DOCUMENT IDENTIFICATION:	1
63 TITLE: ELECTRONIC AGREEMENT TEMPLATE AND PROCESS.....	1
64 GROUP: ELECTRONIC AGREEMENT TEMPLATE AND PROCESS WORK GROUP.....	1
65 TBG2 – DIGITAL PAPERS DOMAIN.....	1
66 VERSION: 0.....	1
67 RELEASE: X.....	1
68 REVISION 2.....	1
69 DATE: JUNE 30, 2006.....	1
701. PREAMBLE.....	2
712. REFERENCES.....	2
723. OBJECTIVE	2
734. SCOPE.....	2
744.1. BUSINESS REQUIREMENTS.....	3
754.2. BUSINESS PROCESS ELABORATION.....	5
764.2.1The Actors.....	5
774.3. ENTERPRISE ELECTRONIC AGREEMENT CUSTOMIZATION – BUSINESS USE CASE.....	6
784.3.1Customize Enterprise electronic model agreement.....	6
794.3.2 ELECTRONIC AGREEMENT NEGOTIATION - BUSINESS USE CASE.....	8
804.3.3 Negotiated electronic model agreement.....	8
814.4 Digitally Sign and Execute Final Joint Electronic Agreement	10
824.4.1Business Information Flow Definition.....	11
834.4.2Customize Enterprise Agreement	11
844.4.3Negotiate Joint Electronic Agreement e-Electronic model agreement.....	12
854.4.4Digitally Sign and Execute Final Electronic Model Agreement.....	13
865 BUSINESS INFORMATION MODEL DEFINITION	13
875.3.1List of Entities (Global Electronic Trading Partner Agreement Entities).....	14
885.3.2Agreement Header Data	20
895.3.3Core Agreement Clause Data	20
905.3.4 BUSINESS AGREEMENT CLAUSE DATA.....	20
915.3.5 ACCEPT /REJECT / COUNTER MENU DATA	20
925.3.6 FINAL ACCEPTANCE / SIGN-OFF DATA	20
935.4 DEFINITION OF TERMS.....	20

94

961. PREAMBLE

97The document authority is TBG2, Digital Papers Domain.

98

99The document structure is based on the UN/CEFACT Business Requirements Specification
100Documentation template Version 1, Release 5.

100

101The document was created by the TBG2 electronic model agreement working group and will be approved
102by the full TBG2 working group in collaboration with TMG and Legal Group.

1022. REFERENCES

103UN/CEFACT Modeling Methodology (CEFACT/TMWF/N090R10, November 2001)

104UN/CEFACT ebXML Core Components Technical Specification Version 2.01

105UN/CEFACT Business Requirement Specification Documentation electronic model agreement, Version 1,
106Release5

106UN/CEFACT TBG Library 2005_10_07

107UML Version 2.0

108AIA of America – Global Trading Partner Agreement (GTPA)

109UN/ECE WP-4 Recommendation 26 – Rev 1 1995 - Trading Partner Agreement

110UNCITRAL - A/CN.9/577 Draft convention for use of electronic communications in international contracts

1113. OBJECTIVE

112The objective is to create a non-refutable, legally executed, electronic model agreement and predictable
113standard process for a supply chain business application. Partners will be enabled to enter electronic
114business agreements to exchange their specific enterprise versions of the agreement and then negotiate
115a consensus of that agreement to specify the terms and conditions of their business arrangement. This
116process must include the designation of a standard mechanism for authenticating digital signatories and
117identity verification and validation.

1134. SCOPE

114This electronic model agreement provides global trading partners with mitigation guidelines addressing
115risks stemming from electronic trading such as information security, legal and privacy policies. The model
116electronic model agreement has been written to align with the regulatory frameworks and legal structures
117for companies engaging in Electronic Business practices. It establishes a common set of rules by which
118trading partners agree to construct and negotiate electronic agreements in a hosted, web based
119environment, thus insuring auditable and non-refutable agreements.

115

116The international standard electronic model agreement focuses on a consistent, predictable format for
117electronic agreements accommodating a standard process to electronically negotiate a mutually agreed
118to contact. The main purposes of this electronic model agreement are listed here:

117

118Provides an electronic model for generic partner information, agreement text and clauses.

119Captures acknowledgement completion indicator of the reviewing partner.

120Includes digital signatures and acceptance at an individual clause level.

121Includes recommendations for configuration management and audit trail of the iterative version of the
122electronic agreement.

122Allows the addition of proposed revisions and comments during the negotiation and in the final electronic
123agreement.

123

124The data categories included in this agreement electronic model agreement are summarized below and
125further defined in Section 5.3, Business Information Model Definition. [_____](#)

125

126

127

1284.1. Business Requirements

129

130The overall business requirements for this electronic model agreement data exchange are illustrated in
131the business operation map below and further discussed in Section 5.1, Business Process Elaboration.

131

132There is a relationship between the electronic model agreement creation for the trading partner enterprise
133model (scenario 1) and the negotiation of a legal electronic agreement by two partners entering into a
134specific contractual business arrangement (scenario 2).

133

134

Business Process Map



135

136

Customize Enterprise Agreement

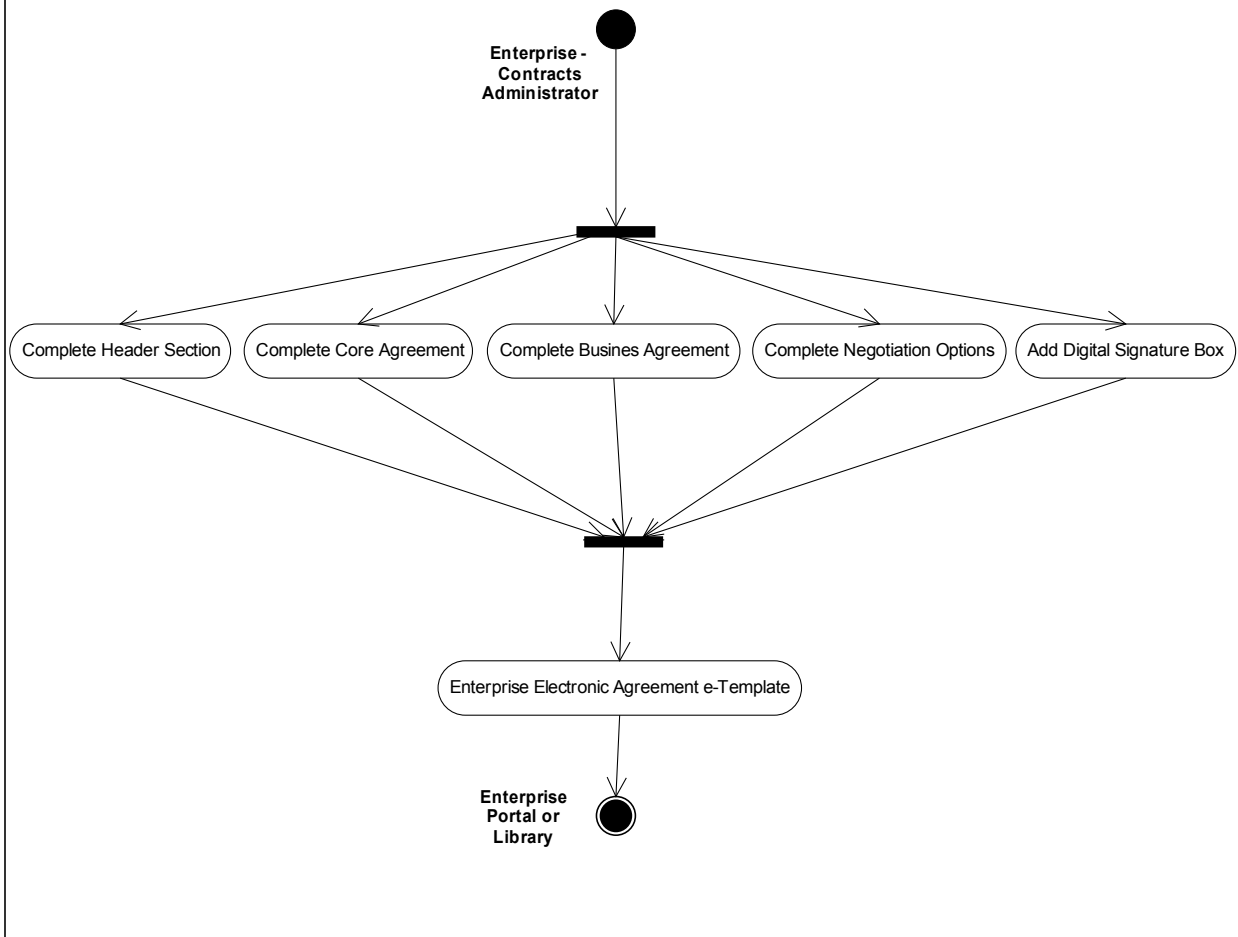

137

138

139 Partner enterprise identification data which includes enterprise or legal entity name, address, responsible
140 negotiation business entity and contact information. A 3rd party partner may represent a contracting
141 partner.

140 Core contract agreement terms conditions and clauses which apply to any contract across all industries
141 and countries.

141 Industry or country-specific contract agreement terms conditions and clauses.

142 Signature box and final acceptance which includes electronic acceptance signatures at the individual
143 clause level and at the final electronic agreement sign off level.

143 Agreement negotiation actions drop-down menu options – which includes:

144 Acknowledge and accept clause without comment

145 Acknowledge and accept clause with comment

146 Reject clause with comment

147 Comment text box

148 Document Management Details:

149 Document status and date

150 Agreement version / revision number

151 Accepted

152 Accepted with proposed changes

153 Rejected

154 Rejected with proposed changes

155

156

1574.2. Business Process Elaboration

1584.2.1 The Actors

159The roles “actors” of the various partners involved in the development of an electronic model agreement
160and the negotiation and execution of a multi-partner consensus version are the initiators or participants in
161the use cases that follow.

Actors

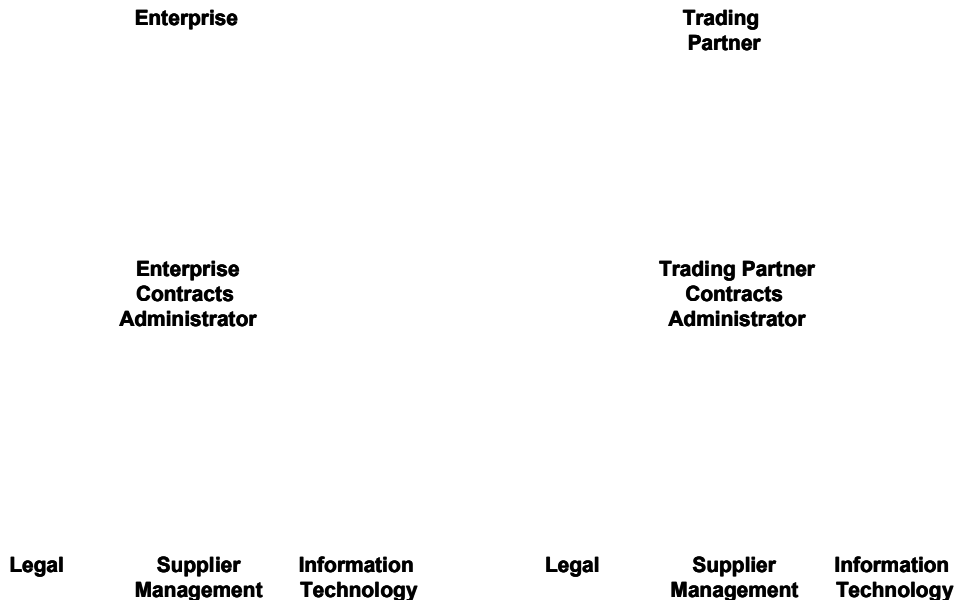

160

161

162**Enterprise contract administration** is responsible for customizing the standard electronic model
163agreement to reflect the enterprise’s model electronic agreement for public display on their enterprise site.
164It is understood they have the authority to establish the electronic model agreement for their enterprise
165and retain ultimate ownership and maintenance rights to that enterprise model agreement.

163

164

- Additional resources such as (noted below) may be used by the contract administrator to develop and / or modify the model agreement:

165

165

- Procurement Manager

166

- Engineering Manager

167

- Information Technology

168

- Legal

169

- Contracts Manager

170

- Program Manager

171

172

173**Trading partner contract administration** is responsible for reviewing and providing counter offers to the
174proposed standard electronic model agreement presented by the enterprise. It is understood the trading
175partner contract administration representative has the authority to negotiate and accept the electronic
176model agreement for their enterprise and retain ultimate ownership and maintenance rights to that
177enterprise model agreement.

174
 175
 176
 177
 178
 179
 180
 181
 182
 183
 184

- Additional resources such as (noted below) may be used by the contract administrator to review and provide comment on the proposed model agreement:
- Procurement Manager
- Engineering Manager
- Information Technology
- Legal
- Contracts Manager
- Program Manager

1854.3. Enterprise Electronic Agreement Customization – Business Use Case

186 This use case applies to the negotiation process conducted between the enterprise and the trading
 187 partner expecting to result in a customized electronic model agreement from a UN/CEFACT or industry
 188 electronic model agreement.

1894.3.1 Customize Enterprise electronic model agreement

190

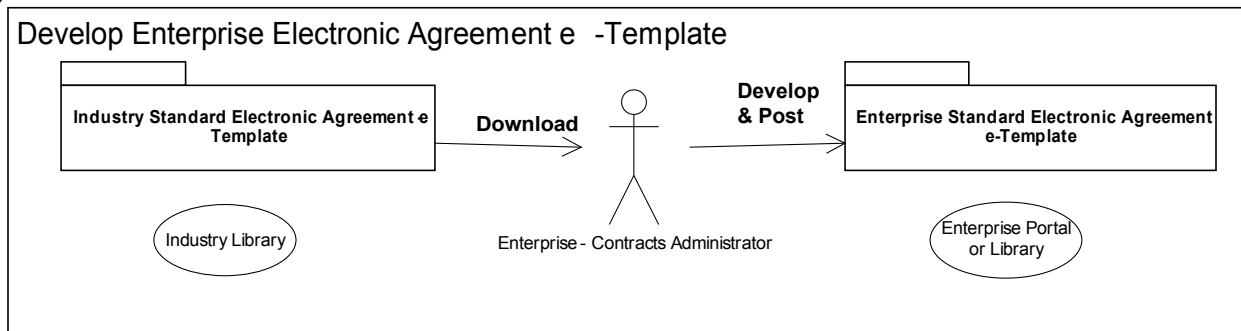

191
 192

Business Process Use Case	
Name	Create and Customize Enterprise Electronic Model Agreement
Use Case ID Number	Electronic Agreement (EA) 1
Description	<p>The enterprise contract administrator accesses industry or enterprise library to obtain model electronic agreement based upon UN/CEFACT Electronic model agreement and process.</p> <p>The enterprise contract administrator customizes the enterprise version of the electronic model agreement and ensures the agreement is accessible the enterprise site for public access by potential trading partners.</p>
Initiating Actor	Contract Administrator
Event Flow	<p><u>Main Scenario</u></p> <p>Contract Administrator obtains industry model of electronic model agreement.</p> <p>Contract Administrator customizes the agreement with enterprise unique requirements.</p> <p>Contract Administrator determines which of the clauses will include the feature to accept / reject options, and will be allowed and activated in the electronic model agreement.</p> <p>Contract administrator will place the enterprise electronic model agreement on the public enterprise portal for access (or delivery by other means) by the trading partner contracts administrator.</p>

	<p>Example 1: An aerospace contractor accesses the Aerospace & Defense Industry library and downloads an industry developed electronic model agreement which may be customized into a enterprise electronic model agreement. This electronic model agreement may be posted on the enterprise's public enterprise site.</p>
Expected Outcome	<p>The enterprise instance of the electronic agreement will utilize UN/CEFACT based electronic model agreement format and rules which will provide the 1st step in producing a non-refutable electronic agreement and auditable process.</p>
Exception	<p>To be defined.</p>
Business Process Data Categories	<p>Contract agreement header data Agreement clause data Business unique clause data Electronic model agreement review and negotiation options menu: Clause review acknowledgement electronic signature Clause accept / reject / modify flag Clause counter-offer text box Final digital signature</p>

193
194

195
196

1974.3.2 Electronic Agreement Negotiation - Business Use Case

198
199 These use cases apply once the enterprise has customized its electronic agreement model and makes it
200 available for the purpose of electronic negotiation with its potential trading partners.
201

202 4.3.3 Negotiated electronic model agreement

203 This is the most typical negotiation scenario that occurs between potential trading partners when
204 jointly developing a contractual agreement defining the basis of their electronic business
205 relationship with one another.
206
207

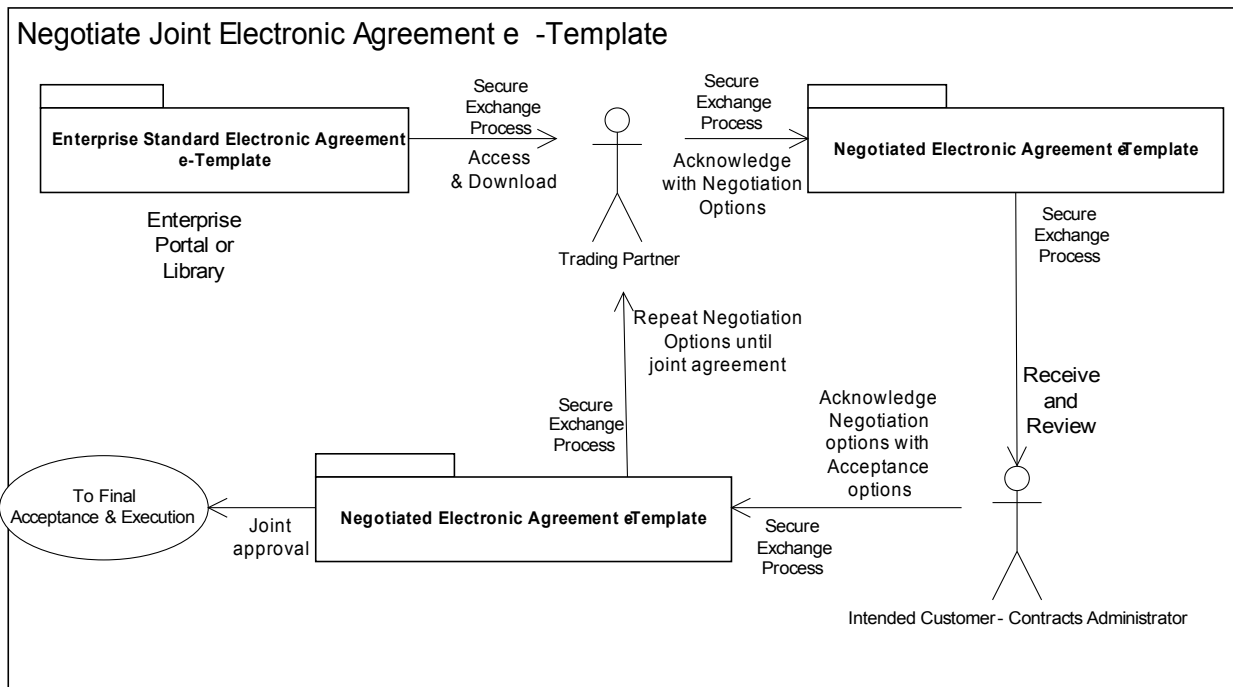

208
209
210

Business Process Use Case	
Name	Negotiated electronic model agreement
Use Case ID Number	EA 2
Description	The Trading Partner obtains the intended enterprise electronic model agreement. The Trading Partner reviews and may accept or produce counter proposal using the electronic model agreement negotiation process. The trading partner uses the standard negotiation process to develop a joint electronic agreement for final execution as evidenced by digital signature.
Initiating Actor	Trading partner contracts administrator
Participating Actor	Enterprise contracts administrator
Event Flow	<u>Main Scenario</u> Trading partner contract administrator obtains intended enterprise's electronic model agreement, e.g. via public enterprise portal, web

	<p>service, email, etc.</p> <p>Trading partner's contract administrators negotiate a joint agreement. Intended enterprise contract administrator reviews trading partner's proposed joint electronic agreement and rejects or accepts with negotiated terms.</p> <p>Electronic exchanges are made to the electronic model agreement are exchanged until both partners either reject or accept the document.</p> <p>When both trading partners accept the negotiated joint electronic agreement final digital sign off (EA 3) process begins.</p> <p>Example 1: Aerospace trading partner wishes to sell parts to a major aerospace Original Equipment Manufacturer (OEM). The trading partner accesses the public portal of the OEM to obtain a Enterprise Electronic model agreement to determine the terms and conditions for conducting business electronically with the OEM. The OEM has used the UN/CEFACT Electronic model agreement rendered in The Aerospace Industry of America's Global Trading Partner Agreement (GTPA). The trading partner accepts the terms and completes the GTPA electronic model agreement by using the UN/CEFACT negotiation process. The trading partner submits the accepted GTPA electronic model agreement to the OEM who accepts it. They both agree to move to the digital sign off process in EA 3.</p>
Expected Outcome	The final joint electronic model agreement will be negotiated using the UN/CEFACT standard negotiation process and document electronic model agreement. The final agreement will be digitally signed in use case EA 3. This standard electronic model agreement and process will produce a non-refutable electronic agreement.
Exception	At any time either partner may choose to terminate the negotiation.
Business Process Data Categories	<p>Contract agreement header data</p> <p>Core agreement clause data</p> <p>Business specific agreement clause data</p> <p>Electronic model agreement review and negotiation options menu data:</p> <ul style="list-style-type: none"> Clause review acknowledgement electronic signature Clause accept / reject flag Clause counter offer text box data <p>Final digital signature.</p>

211
212
213
214
215
216
217
218
219
220
221
222
223
224
225
226
227
228

229

4.4 Digitally Sign and Execute Final Joint Electronic Agreement

230

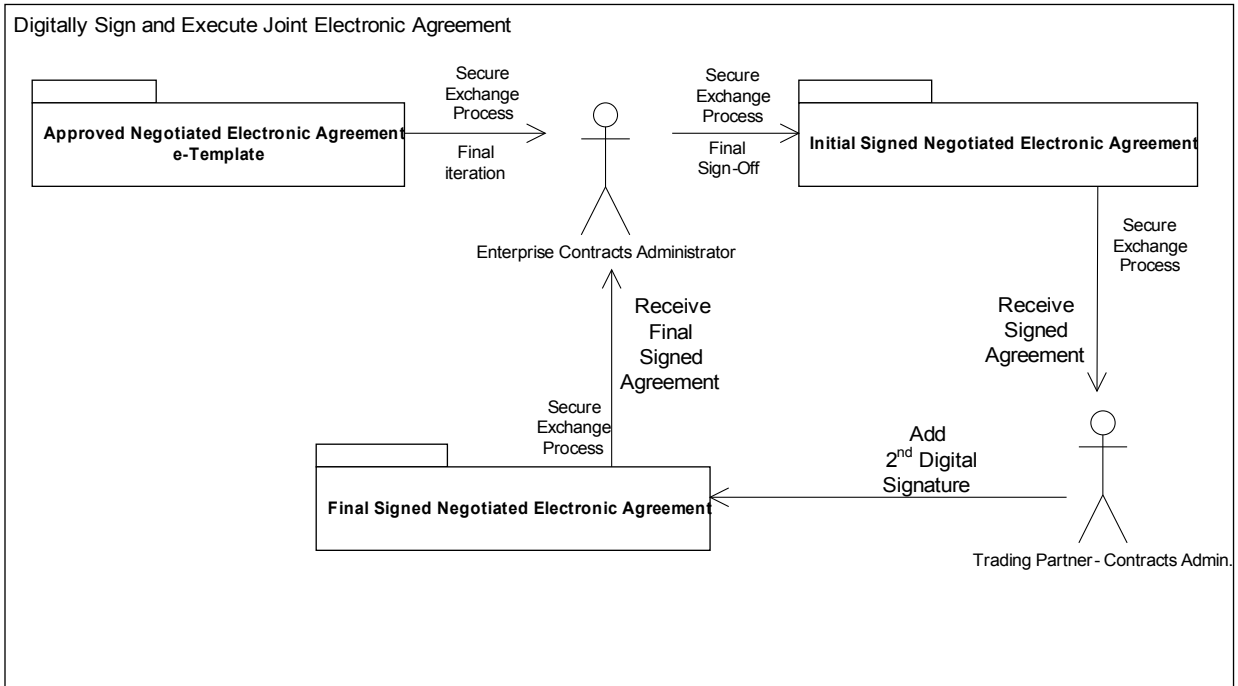

231

232

Business Process Use Case	
Name	Execute, digitally sign and retain final electronic model agreement
Use Case ID Number	EA 3
Description	At such time that both negotiating partners agree to the content of the joint electronic model agreement the designated digital signature protocol should be employed as well as the final digital signatures. Negotiations are considered concluded after both partners digitally sign the joint agreement.
Initiating Actor	Either partner may initiate the final sign off use case - trading partner contracts Administrator or enterprise contracts administrator
Participating Actor	The remaining partner is the secondary participant
Event Flow	<u>Main Scenario</u> Either partner may conclude the negotiation process by accepting the electronic model agreement proposed by the other partner. At that time that enterprise will digitally sign off (and digitally lock all but signature box) the joint agreement electronic model agreement instance and forward the electronic model agreement to trading partner for digital signature. The second (final) signer of the electronic agreement will retain an electronic copy of the electronic model agreement documents and forward a final copy to the other partner.
Expected Outcome	Both partners may retain an electronic copy of the executed electronic model agreement.
Exception	At any time either partner may terminate negotiation
Business Process Data Categories	Contract agreement header data Core agreement clause data Business specific agreement clause data

Electronic model agreement review and negotiation options menu data: Clause review acknowledgement electronic signature Clause accept / reject flag Clause counter offer text box data Final digital signature
--

233

2344.4.1 Business Information Flow Definition

235The activity diagrams further illustrate the data flow that occurs between the contracting partners. These
 236are very simple data flows where both partners are iteratively refining an electronic model agreement
 237proposed by one or both of them to cover their proposed business arrangement.
 238

2394.4.2 Customize Enterprise Agreement

240This activity diagram illustrates the data development process top produce a enterprise electronic model
 241agreement from a standard industry or organization electronic model agreement based upon standard
 242UN/CEFACT Electronic Agreement model agreement and process.

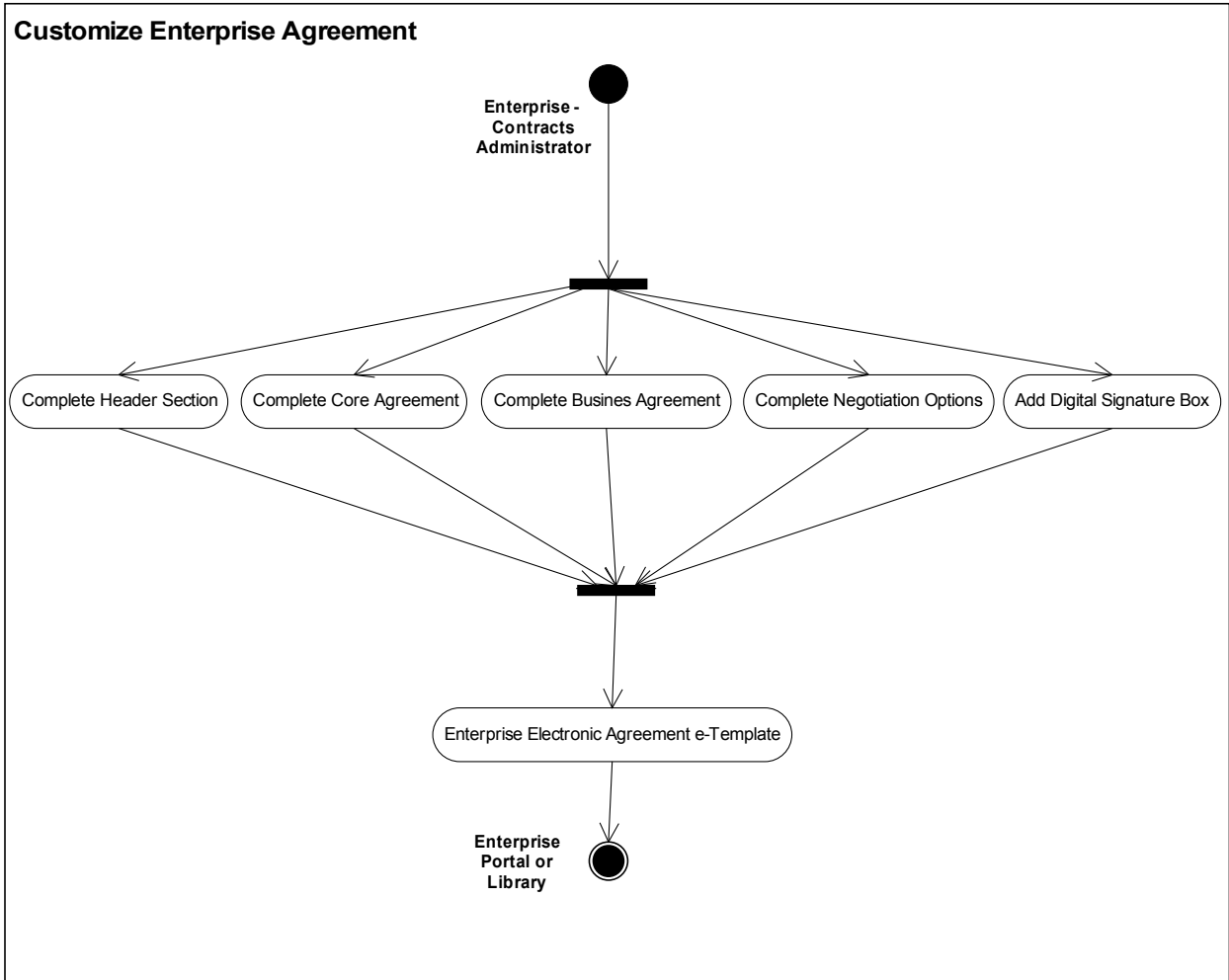

243

2444.4.3 Negotiate Joint Electronic Agreement e-Electronic model agreement

245 This activity diagram illustrates the data flow for the agreement negotiation and completion of the sections
246 of the electronic model agreement.

247

248

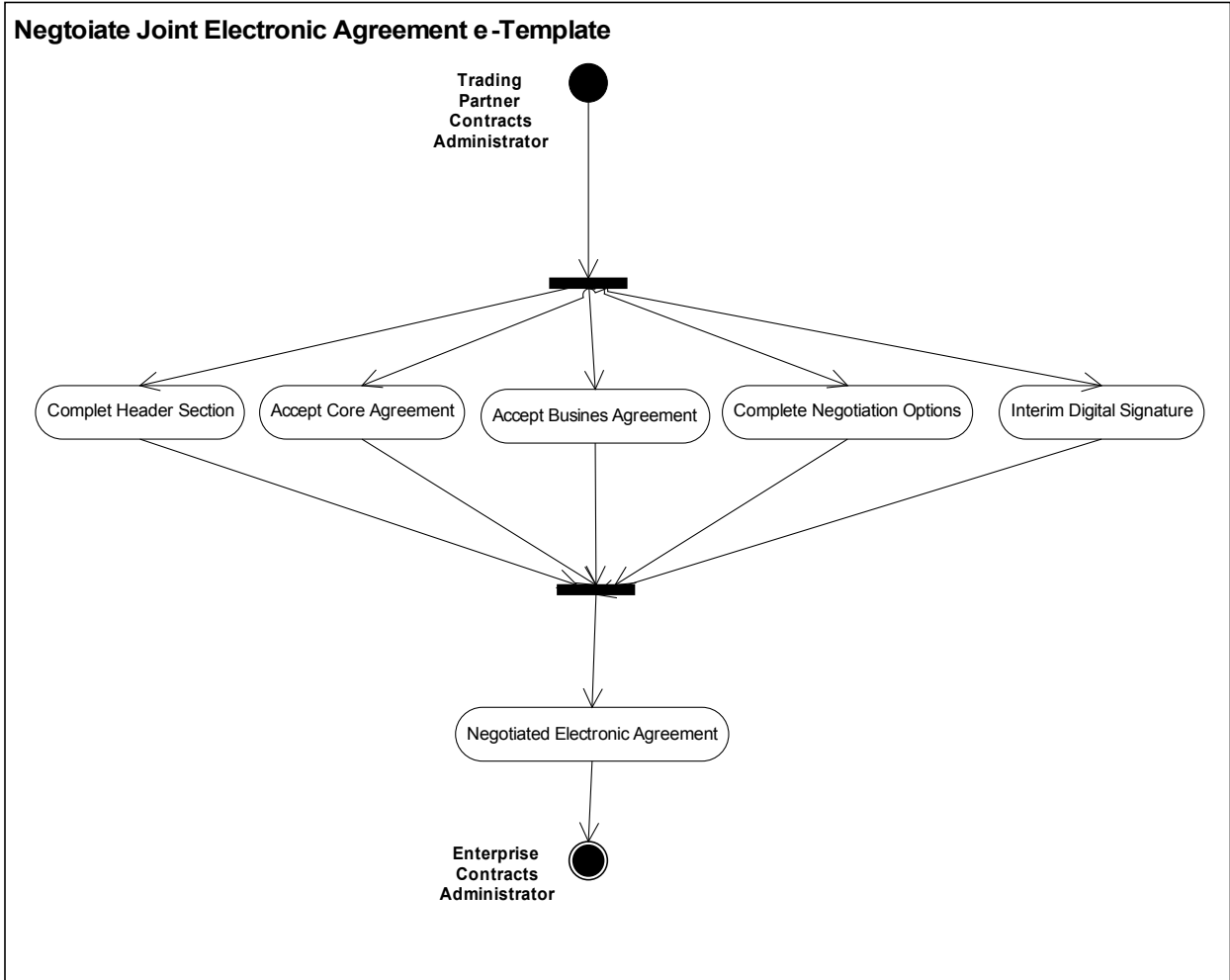

249

250

251

2524.4.4 Digitally Sign and Execute Final Electronic Model Agreement

253 This activity diagram illustrates the data flow for the final sign off and business execution of the final
254 electronic model agreement

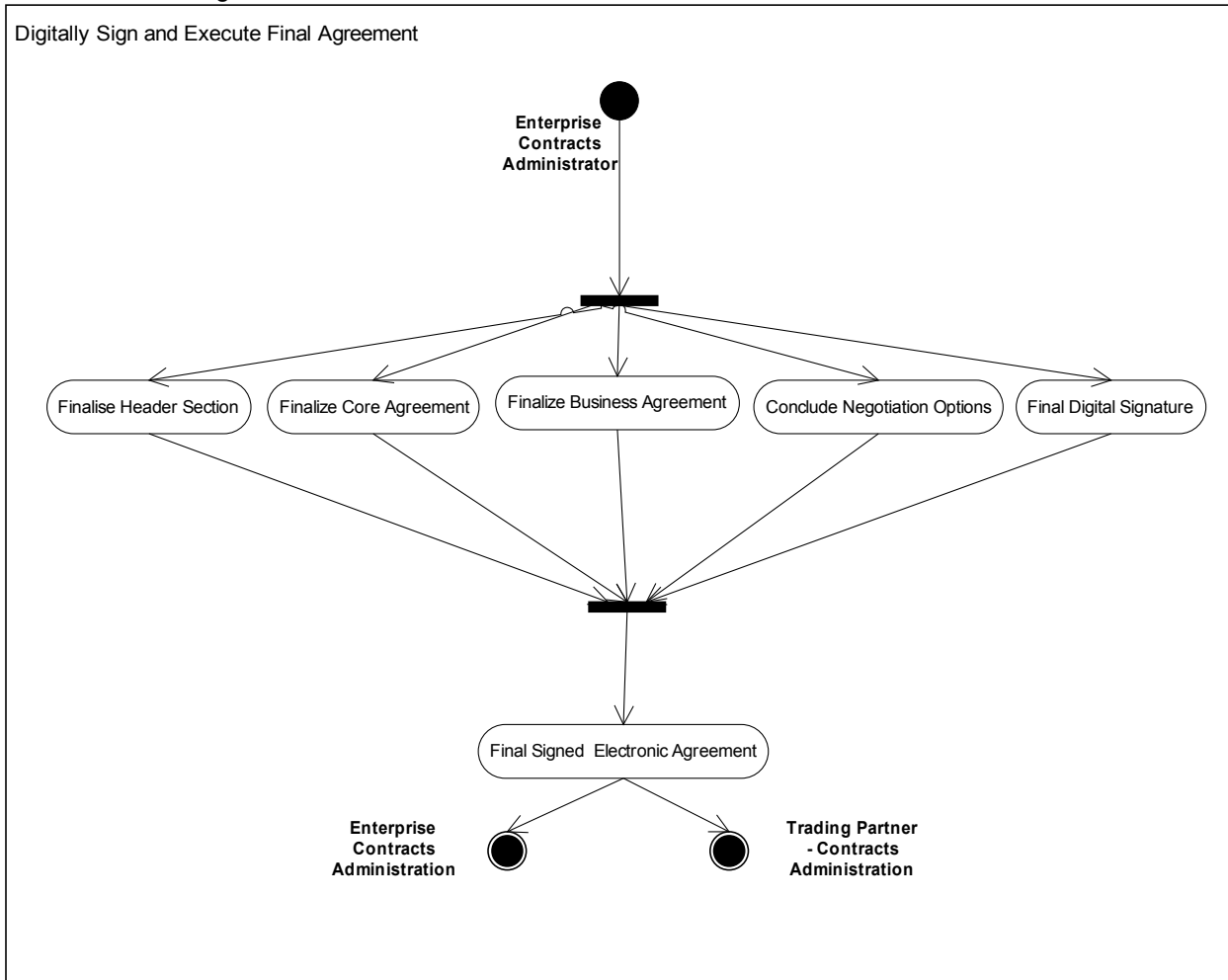

254
255
256

2575 BUSINESS INFORMATION MODEL DEFINITION

258 Section 5.3.1 lists the entities used for the five main information areas identified in the use cases
259 described in Section 5.1. The five main information areas will include:

- 259
- 260 Agreement header data (Section 5.3.2)
- 261
- 262 Core agreement clause data (Section 5.3.3);
- 263
- 264 Business agreement clause data (Section 5.3.4)
- 265
- 266 Accept / reject / counter offer menu data (Section 5.3.5);
- 267
- 268 Final acceptance / sign off data (Section 5.3.6);

269 Where applicable for each electronic model agreement development or negotiation information area,
271 targeted data exchanges are identified. The intent is to allow the ability to negotiate and accept versions

271of an electronic model agreement. Example use case scenarios are included to further illustrate how
 272negotiation may take place.

2725.3.1 List of Entities (Global Electronic Trading Partner Agreement Entities)

273The following is an alphabetical list and business use description of the proposed entities that the four
 274electronic model agreement areas will use to achieve a mutually acceptable version of the electronic
 275agreement

274

275These entities will be further described in the related Requirements Mapping Specification (RMS) which
 276provides the data element details. The purpose of the following list is to provide a general description of
 277the entities.

276

ENTITY	DESCRIPTION
SCOPE	Identifies the Legal Entity names of the partners entering into the agreement as well as the agreement start and stop dates.
PURPOSE	Enterprise and Trading Partner will facilitate commerce by electronically transmitting and receiving data in preference to exchanging paper documents. Enterprise and Trading Partner intend that contracts formed by electronically transmitting data will be as enforceable as contracts formed by any other means. Nothing in the Agreement precludes Enterprise and Trading Partner from entering into contracts by any other means.
DEFINITIONS	<p>“Acknowledgment” means an electronic indicator verifying receipt or access of the Data.</p> <p>“Authorized Representative” means an individual or individuals delegated the authority to legally represent the Enterprise and Trading Partner.</p> <p>“Data” means any information transmitted/accessed electronically between Enterprise and the Trading Partner.</p> <p>“Data Records” means in computer data processing, a record is a collection of data items arrange for processing by a program. Multiple records are contained in a file or data set.</p> <p>“Electronic” means or relates to information created, recorded, transmitted or stored in digital form or in other intangible form by electronic, magnetic or optical means or by any other means that has capabilities for creation, recording, transmission or storage similar to those means and has a corresponding meaning.</p> <p>“Electronic-Trading” means an electronic communication involving an electronic exchange of data for commerce purposes.</p> <p>“Exhibit” means a supplement to this Agreement.</p> <p>“Offices In” may be either the Enterprise or Trading Partner Legal Entity, or the location of Electronic Commerce Operations.</p> <p>“Original” means the first instantiation of the transmission of data from the originating source application.</p> <p>“Parties” Means the Enterprise and the Trading Partner.</p> <p>“Personal Data” shall mean any information relating to an identified or identifiable natural person; an identifiable natural person is one who can be identified, directly or indirectly, in particular by reference to an identification number or to one or more factors specific to his physical, psychological, mental, economic, cultural or social identity.</p> <p>“Prompt and Promptly” means done quickly and without delay, or (of a person) acting quickly.</p> <p>“Properly” means received in a usable format.</p>

	<p>“Service Provider” or “Provider” shall mean a Third Partner that provides enabling technologies and services for the purpose of conducting electronic commerce</p> <p>“Third Parties” means the Subcontractor to the Enterprise and, or the Trading Partner. Separate contractual obligations are established between the Enterprise and or the Trading Partner and the Third Partner, and are not subject to this agreement.</p> <p>“Underlying Agreement,” means the document containing the Terms and Conditions of the business relationship between the two contracting parties.</p>
SYSTEM OPERATIONS	Each partner, at its own expense, will provide and maintain the equipment, software, and services necessary to reliably and securely, transmit, receive, access and control Data. Each partner will periodically test and monitor such equipment, software, and services to ensure that they are adequate to reliably and securely, transmit, receive, access and control Data.
DATA EXCHANGE	<p>When one partner electronically transmits Data to the other partner in accordance with the applicable Exhibit, the other partner shall receive the Data.</p> <p>In General: Return receipts shall be evidence that the transmission was received. Acknowledgement of receipt of Data exchange is required. Data must be received in a useable format within the parameters of the protocols defined for receiving transmissions and acceptance of data defined herein. Should a return receipt not be received within the mutually agreed time frame, it shall be the responsibility of the transmitting partner to investigate and remedy the failed transmission.</p> <p>Garbled/Lost Transmissions/Service Outages: If a partner receives unintelligible Data, that partner will promptly notify the sending partner (if identifiable from the received Data). If the sending partner is identifiable from the Data but the receiving partner fails to give prompt notice that the Data is unintelligible, the records of the sending partner will govern. If the sending partner is not identifiable from the Data, the records of the partner receiving the unintelligible Data will govern. Widespread denial of service or service outages may require contingency operations.</p> <p>System Changes: Either partner must give ninety (90) days notice of intent to upgrade to a new standard or implementation convention. Either Partner may select, or may change a standard, upon ninety (90) days notice to the other partner, provided that Exhibits are subsequently modified to reflect such changes. All changes in format require mutual amendment of applicable Exhibits to ensure both parties are capable of transmitting/receiving such formats.</p>
MEANS OF TRANSMISSION	Either partner will transmit Data directly to one another or through a Service Provider. Either partner may select or modify the transmission protocol or the selection of a Service Provider upon thirty (30) days written notice to the other partner. Proposed changes in Service Providers, having material impact to the contract, shall be subject to mutual agreement and subsequent

	<p>amendment of applicable Exhibits.</p> <p>Each partner will be solely responsible for the costs of any Service Provider with which it contracts.</p> <p>Each partner warrants that its Service Provider has been placed under a contractual obligation stipulating that in performing its services, the Service Provider shall make no change to Data and shall not disclose such Data to any Third Partner without prior written approval.</p> <p>Each partner will be liable to the other for the acts or omissions of its Provider while transmitting, receiving, storing or handling Data. If both parties use the same Provider, the Transmitting partner will be liable to the other for acts or omissions of the Service Provider, as related to that Data.</p> <p>Exhibit (A) defines the protocols used and categories of Data exchanged that will be subject to this agreement.</p>
DIGITAL SIGNATURES	<p>Each authorized representative of a partner should (as appropriate) adopt a unique, verifiable electronic digital identification consisting of symbols or codes to be logically associated with each transmission. The parties will define those transmissions subject to a digital signature; and incorporate said list as an Exhibit (B) hereto. The Third Partner security services authority shall be defined within an Exhibit to this Trading Partner Agreement. Use of the electronic digital identification will be deemed for all purposes to constitute a "signature" and will have the same effect as a signature on a written document. Neither partner shall contest the validity of a transmission of a document transmitted electronically on the basis that a transmission contains an electronic signature. Each representative of a partner authorized to transmit transactions electronically will maintain sole control of the use of his or her digital identification and electronic signature. Each partner shall have policies and procedures in place to ensure the security of digital signatures.</p>
TRANSACTION SECURITY	<p>Each partner will provide appropriate security measures to ensure that all transmission of Data is authorized and to protect Data from unauthorized access, alteration, or loss. Each partner will use appropriate care to maintain the confidentiality of transactions and the Data therein in the same secured manner as it would maintain for paper documents of like kind and importance.</p> <p>If the Underlying Agreement does not provide for the protection of confidential or proprietary data, Data containing confidential or proprietary information must be conspicuously stated to be confidential or proprietary by the partner sending the Data, and must not be disclosed to any Third Partner (other than a Provider of a transmission service for such Data in so far as the Provider needs to have Data disclosed to it for the purposes of transmission) without the prior consent of the transmitting partner or used by the receiving partner other than for the purposes of the business transaction to which it relates, provided that no such obligations of confidentiality shall apply in respect of information which:</p> <ul style="list-style-type: none"> Is in the public domain (other than by breach of the recipient partner of its confidentiality obligations hereunder); or Is in the receiving partner's possession without restriction; or Has been lawfully received by the receiving partner without notice of confidentiality obligations from a Third Partner

		<p>entitled to disclose it; or Has been developed independently by the receiving partner.</p> <p>No right beyond what is specified within the Underlying Agreement for use of Data is granted by this agreement. All rights of use shall be granted within the Underlying Agreement.</p> <p>Unless otherwise agreed in the Underlying Agreement, the period of confidentiality shall be five (5) years from the date the confidential data was received by either the Enterprise or the Trading Partner. The periods of confidentiality contained in the Agreement are subject to the exclusions and other provisions under the heading "Confidentiality" in the underlying terms and conditions.</p> <p>Where permitted by law, the Parties may apply special protection to Data by encryption or by other agreed means including those set out in the Exhibit. Unless the Parties otherwise agree, the recipient of Data so protected shall use at least the same level of protection for any further permitted onward transmission of such Data. Further protection may be needed if the messages contain Personal Data, and should be in compliance with the law of the governing jurisdiction of the transmitting partner. The use and disclosure of personal data is subject to the laws of the governing jurisdiction of the receiving partner.</p>
ENFORCEABILITY AND ADMISSIBILITY	AND	<p>The Parties agree that any Data properly transmitted pursuant to this Agreement will be deemed for all purposes: (1) to be a "writing" or "in writing;" and (2) to constitute an "original" in the ordinary course of the Trading partners' business. The Parties agree that to the extent permitted by law the Data Records maintained by the Parties shall be admissible in adversarial proceedings and may be used as evidence of the information contained in them.</p> <p>Any Data digitally signed pursuant to Section 7 and electronically transmitted pursuant to this Agreement will be as legally sufficient as written, signed, paper documents exchanged between the parties, notwithstanding any legal requirement that the Data be in writing or signed. Unsigned transmitted data will be deemed legally equivalent to unsigned transmitted paper documents.</p> <p>The conduct of the parties pursuant to the Underlying Agreement, including the use of Data properly transmitted hereunder, shall, for all legal purposes, evidence a course of dealing and a course of performance accepted by the parties in furtherance of the purpose of these Agreement terms.</p>
INCIDENTAL AND CONSEQUENTIAL DAMAGES		<p>Except for a breach of clause 21. NEITHER PARTNER WILL BE LIABLE TO THE OTHER FOR ANY SPECIAL, INCIDENTAL OR CONSEQUENTIAL DAMAGES ARISING FROM OR AS A RESULT OF THE DELAY, OMISSION OR ERROR IN AN ELECTRONIC TRANSMISSION OR SENT OR RECEIVED PURSUANT TO THESE AGREEMENT TERMS.</p>
LIMITATION OF LIABILITY		<p>If the Underlying Agreement contains a Limitation of Liability clause, the Limitation of Liability clause in the Underlying Agreement will also apply to transmissions sent pursuant to this Agreement.</p>
TERMS AND TERMINATION		<p>This Agreement shall take effect from the last date of signature of this Agreement.</p> <p>Either partner may terminate this Agreement by giving the other</p>

	<p>partner at least thirty (30) days prior written notice specifying the effective date of termination. Any termination will not alter the rights or duties of the parties with respect to Data transmitted before the effective date of the termination.</p> <p>In the event that either partner shall at any time during the term of this Agreement:</p> <p>Be in breach of its obligations hereunder where such breach is irremediable or (if capable of remedy) is not remedied within thirty (30) days of notice from the other partner requiring its remedy; or</p> <p>Be or become bankrupt or insolvent or make any compensation with its creditors or have a receiver or manager appointed for the whole or any part of its undertaking or assets or (otherwise than as a solvent enterprise for the purpose of and followed by an amalgamation or reconstruction where under its successor shall be bound by its obligations hereunder) commence to be wound up;</p> <p>The other partner may forthwith by notice in writing terminate this Agreement. Survival, all identities, warranties and representations made under the agreement and all accrued obligations under the agreement will survive cancellation or termination of the agreement.</p>
NATURE OF AGREEMENT	This Agreement does not express or imply any commitment to purchase or sell goods or services or to conduct any business transaction.
WAIVER	No exercise or failure to exercise or any delay in exercising any right power or remedy vested in either partner under or pursuant to this Agreement shall constitute a waiver by that partner of that or any other right power or remedy.
ASSIGNMENT	Neither partner shall assign, subcontract charge or otherwise deal with or dispose in any way of its rights or obligations hereunder without the prior consent of the other partner, save that no such consent is required in the event of the internal reconstruction or reorganization of a partner.
SEVERABILITY	Notwithstanding that the whole or any part of any provision of this Agreement may prove to be illegal or unenforceable the other provisions of this Agreement and the remainder of the provision shall remain in full force and effect. Unless otherwise agreed by the parties, the provisions of this Agreement are not intended to govern the contractual obligations arising from the underlying transactions effected by the use of electronic commerce except as provided at clauses 5 and 7 hereto.
FORCE MAJEURE	Parties shall not be liable line for any failure to perform their obligations required by any transaction or any Data, where such failure results from any act of God or other cause beyond these partner's reasonable control including, without limitation, any mechanical, electronic or communications failure which prevents such parties from transmitting or receiving any documents.
CONFLICT RESOLUTION	Alternative dispute resolution is encouraged, however, either partner may litigate any dispute arising under or relating to this Agreement: Pending resolution of any such dispute by settlement or final judgment, the parties shall proceed diligently with the terms of this Agreement.

	<p>Disputes, controversies or claims arising out of this Agreement that involve parties based within the same national boundary shall be brought and jurisdiction and venue shall be proper only in (specify court and country (insert pull down menu here). replace with blank fill in line)</p> <p>Disputes, controversies or claims arising out of this Agreement that involve parties residing in different countries shall be finally settled under the rules of arbitration of the International Chamber of Commerce by three (3) arbitrators, unless otherwise decided, appointed in accordance with the said rules. The language of the arbitration shall be English (unless otherwise agreed to) and the place of arbitration shall be _____ . Another jurisdiction may apply to give effect to the findings of the arbitration.</p> <p>NOTE: The blank filed will be pre-populated by the prime</p>
ORDER OF PRECEDENCE	<p>In the event of a conflict between the Underlying Agreement and the Trading Partner Agreement, the Underlying Agreement shall take precedence.</p>
NOTICES	<p>All notices required to be given under this Agreement, except for those communications forming a part of transactions, shall be in writing and shall be sent by written or electronic means, return receipt requested, to the parties as follows: [at the offices detailed in clause 1 of this Agreement.]</p> <p>If delivered by hand, notice will be deemed delivered on the day of delivery if it is the recipient's business day and otherwise on the recipient's first business day immediately following delivery;</p> <p>If delivered by hand by a Commercial Express Delivery Service, notice will be deemed delivered to the receiving partner on the third business day (or on the tenth business day, in the case of airmail) after collection by the Commercial Express Delivery Service;</p> <p>If sent by facsimile, telex or other electronic means;</p> <p>i) If transmitted between 09:00 and 17:00 hours on a business day (recipient's time) on completion of receipt by the sender of verification of the transmission from the receiving instrument; o</p> <p>ii) If transmitted at any other time, at 09:00 on the first business day (recipient's time) following the completion of receipt by the sender of verification of the transmission from the receiving instrument.</p>
EXPORT	<p>Where the Data is being transmitted from one country to another, the transmitting partner warrants that it has obtained all necessary approvals that comply with the export control and economic sanction laws applicable to the export of such Data to the receiving partner.</p> <p>Where the Data is being transmitted from one country to another, the transmitting partner warrants that it complies with all encryption-related regulatory requirements of the transmitting partner's country, which apply to the transmission of such data to the receiving partner. The receiving partner warrants that it has obtained all necessary authorizations for the use of encryption technology.</p> <p>There is an obligation on the receiving partner not to transmit data on to another country, except by prior approval of the transmitting partner and any applicable laws and regulations of the transmitting partner.</p>

RECORDS MANAGEMENT AND RECORDS RETENTION	For a period of three (3) years after final payment or as defined under the Underlying Agreement, Trading Partner and Enterprise shall maintain all related books, records, and documents generated as a result of this agreement.
GOVERNING LAW	The agreement shall be construed under and governed by the law of the (insert appropriate country/state) without regard to conflict of law provisions.
ENTIRE AGREEMENT	This Agreement and the Exhibits constitutes the complete agreement of the parties relating to the electronic transmission of Data as specified within this Agreement and supersedes all prior representations or agreements, whether oral or written, with respect to such matters.
	Enterprise: (pre-loaded by the prime)
	Trading Partner: (completed when accepted by the supplier)

277

278

279

280 **To be completed for and during the Agreement Template development work:**

2815.3.2 Agreement Header Data

2825.3.3 Core Agreement Clause Data

2835.3.4 BUSINESS AGREEMENT CLAUSE DATA

2845.3.5 Accept /Reject / Counter menu Data

2855.3.6 Final Acceptance / Sign-Off Data

2865.4 Definition of Terms

Enterprise	Any entity engaging in business, such as a proprietorship , partnership , or corporation . May also be termed company.
Contract Administrator	Enterprise representative with the authority to sign contracts, on behalf of the enterprise with an external party which would commit the enterprise to perform work, incur obligations or accept liability.
Execution, Execute, Executed	Validation of a legal document by the performance of all necessary formalities.
Trading Partner	Any entity conducting electronic transactions with another entity.

287

288 **END OF DOCUMENT**

289