

Distr.
GENERAL

TRANS/WP.29/GRSG/2001/14
13 July 2001

Original: ENGLISH

ECONOMIC COMMISSION FOR EUROPE

INLAND TRANSPORT COMMITTEE

World Forum for Harmonization of Vehicle Regulations (WP.29)

Working Party on General Safety Provisions (GRSG)
(Eighty-first session, 8-11 October 2001,
agenda item 4.)

PROPOSAL FOR DRAFT AMENDMENTS TO REGULATION No. 66
(Strength of superstructure)

Transmitted by the Expert from Hungary

Note: The text reproduced below was prepared by the expert from Hungary in order to update the Regulation. It is based on a document distributed without a symbol (informal document No. 4) during the eightieth session of GRSG (TRANS/WP.29/GRSG/59, para. 22).

Note: This document is distributed to the Experts on General Safety Provisions only.

GE.01-

Insert a new annex 5, to read:

"Annex 5

ROLLOVER OF FULL SCALE VEHICLE AS THE BASIC APPROVAL TEST METHOD

1. The tilting test bench
 - 1.1. The tilting platform shall be rigid enough and rotated so that the simultaneous lifting of the axles of the vehicle shall be ensured. No bigger difference than 1° is allowed between the tilting angle of the platform below each axle.
 - 1.2. The height difference between the horizontal lower plane of the ditch (see figure A1.) and the plane of the tilting platform on which the bus is standing, shall be 800 ± 20 mm
 - 1.3. The tilting platform, related to the ditch, shall be placed as follows (see figure A1.):
 - 1.3.1. the axis of its rotation is max 100 mm from the vertical wall of the ditch;
 - 1.3.2. the axis of the rotation is max 100 mm below the plane of the horizontal tilting platform;
 - 1.4. Wheel supports shall be applied at the wheels being close to the axis of rotation against sliding of the vehicle sideways when tilting it. The main considerations of wheel supports shall be (see figure A1).
 - 1.4.1. dimensions of one wheel support:

Height	80 mm
Width	20 mm
Edge radius	10 mm
Length min.	500 mm
 - 1.4.2. the wheel supports at the widest axle shall be placed on the tilting platform so that the side of the tyre from the axis of rotation is 20 mm;
 - 1.4.3. the wheel supports at the further axles shall be adjusted so that the longitudinal axis of the vehicle shall be parallel to the axis of rotation;
 - 1.5. Means shall be provided on the tilting platform to prevent the vehicle moving along its longitudinal axis
 - 1.6. The impact area of the ditch shall have a horizontal, uniform concrete surface

2. Preparation of tested vehicle
 - 2.1. The vehicle to be tested need not be in a fully finished, "ready for operation" condition. Any alteration from the fully finished condition is acceptable if the basic feature and behaviour of the superstructure is not influenced by it. The test vehicle shall be the same as its fully finished version in respect of the following:
 - 2.1.1. the position of the centre of gravity, the value of unladen kerb mass and the distribution and location of masses as declared by the manufacturer;
 - 2.1.2. all of those elements which, at the manufacturer's discretion, contribute to the strength of the superstructure shall be installed in their original position (see annex [X₂] to this Regulation);
 - 2.1.3. elements, which do not contribute to the strength of the superstructure and they have too great value for damage (e.g. drive chain, dashboard instrumentation, driver's seat, kitchen equipment, toilet equipment, etc.) can be replaced by additional elements being equivalent in mass and the way of installation. These additional elements must not have reinforcing effect on the strength of the superstructure;
 - 2.1.4. fuel, battery acid and other combustible, explosive or corrosive materials may be substituted by other materials provided that the conditions of paragraph 2.1.1. are met.
 - 2.2. The test vehicle shall be prepared as follows:
 - 2.2.1. tyres shall be inflated to the pressure prescribed by the manufacturer;
 - 2.2.2. all axles of the vehicle, the spring and suspension system shall be fixed. The floor of the vehicle shall be horizontal on the horizontal tilting platform, the floor height shall be according to the manufacturer specification for unladen vehicle;
 - 2.2.3. every door and opening window of the vehicle shall be closed but not locked.
 - 2.3. If the rigid section of an articulated vehicle is tested, which has only one axle, the artificial support, applied at the articulated hinge (see paragraphs 5.6.1. and 5.6.2. of the Regulation) shall meet the following requirements:
 - 2.3.1. it shall be fixed to the structure on a way that it must not cause either reinforcement or extra additional load to the superstructure
 - 2.3.2. it shall be strong (rigid) enough that during the tilting and the rollover process it must not get any deformation which could change the direction of the rollover of the vehicle
 - 2.3.3. its mass shall be equal to the mass of those elements, parts of the articulated joint, which nominally belong to the tested vehicle part, but which are not placed on it (e.g. turntable and its floor, handholds, rubber boots, etc.)

- 2.3.4. its centre of gravity shall have the same height as the common centre of gravity of those parts which are mentioned in paragraph 2.3.3.
3. Test procedure, test process
 - 3.1. The rollover test is a very rapid, dynamic process in time having distinguishable stages, which are described in the appendix. These should be taken into consideration when a rollover test and its instrumentation, the measurements are planned.
 - 3.2. The vehicle shall be tilted without rocking and without dynamic effects until its rolls over. The angular velocity shall not exceed 5 degrees per second (0,087 rad/sec).
 - 3.3. For inside observation high-speed photography, video, deformable templates, electrical contact sensors or other suitable means shall be used to determine that the requirements of paragraph 5.1. in the main text of this Regulation have been met. This shall be verified at any place of the passenger compartment where the residual space seems to be endangered, the exact positions being at the direction of the technical service. At least two positions, nominally at the front and rear of the passenger compartment shall be used.
 - 3.4. Outside observation and certification of the rollover and deformation process is recommended, which means the following:
 - 3.4.1. two high-speed cameras - one from the front and another from the back - are recommended to be used. They shall be located:
 - far enough from the front and rear wall of the vehicle to avoid the distortion of the picture (to produce measurable picture)
 - in the range of the shaded area shown on figure A2/a.
 - 3.4.2. at least the position of the centre of gravity and the contour of the superstructure (see figure A2/b) is recommended to be marked by stripes and bands to ensure correct measurements on the pictures.
4. Documentation of the rollover test
 - 4.1. Detailed description of the tested vehicle shall be given by the manufacturer in which:
 - 4.1.1. all the deviations between the fully finished, ready for operation vehicle type and the tested vehicle are listed.
 - 4.1.2. the equivalent substitution (in respect of mass, mass distribution and installation) shall be proved in every case, when structural parts, units are substituted by other units or masses.
 - 4.1.3. a statement is needed about the position of centre of gravity in the tested vehicle which may be based on:
 - measurement carried out on the vehicle to be tested when it is ready for test

- combination of measurement (carried out on the fully finished vehicle type) and calculation based on the mass substitutions.
- 4.2. The test report shall contain all the data, information (pictures, records, drawings, measured values, etc.) which shows:
- 4.2.1. that test was carried out according to this annex;
 - 4.2.2. that the requirements of paragraphs 5.1.1. and 5.1.2. of this Regulation are met (or not);
 - 4.2.3. the individual evaluation of inside observations;
 - 4.2.4. all the data and information needed for the identification of the vehicle type, the tested vehicle, the test itself and the person, responsible for the test and its evaluation;
- 4.3. It is recommended to document in the test report the centre of gravity'-s highest and lowest position related to the ground level of the ditch.

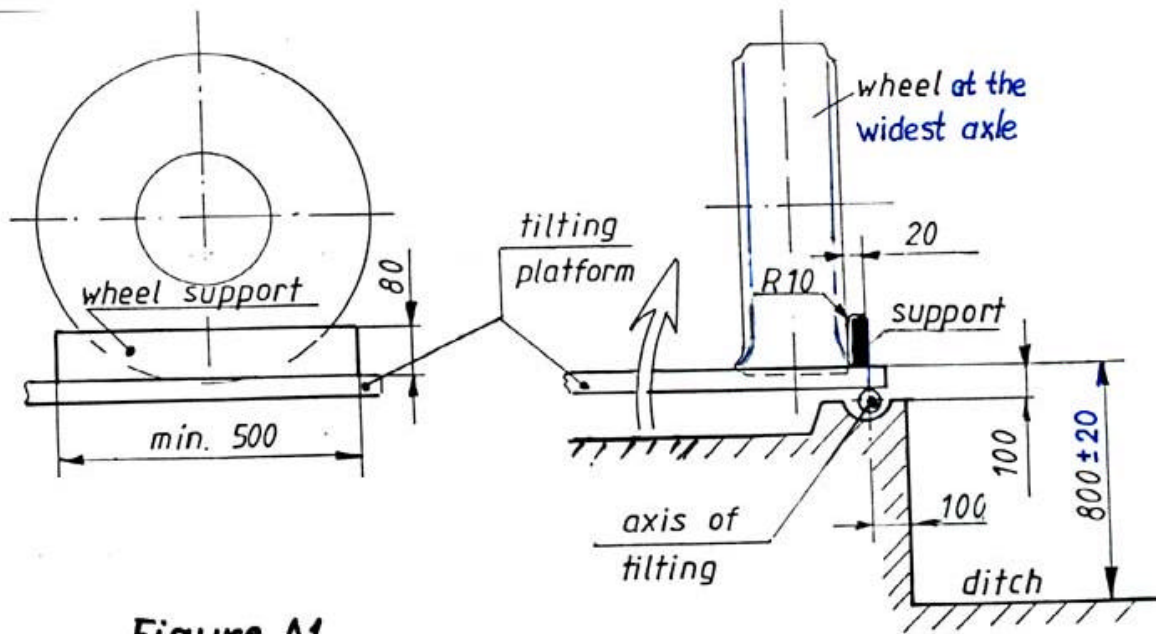

Figure A1.

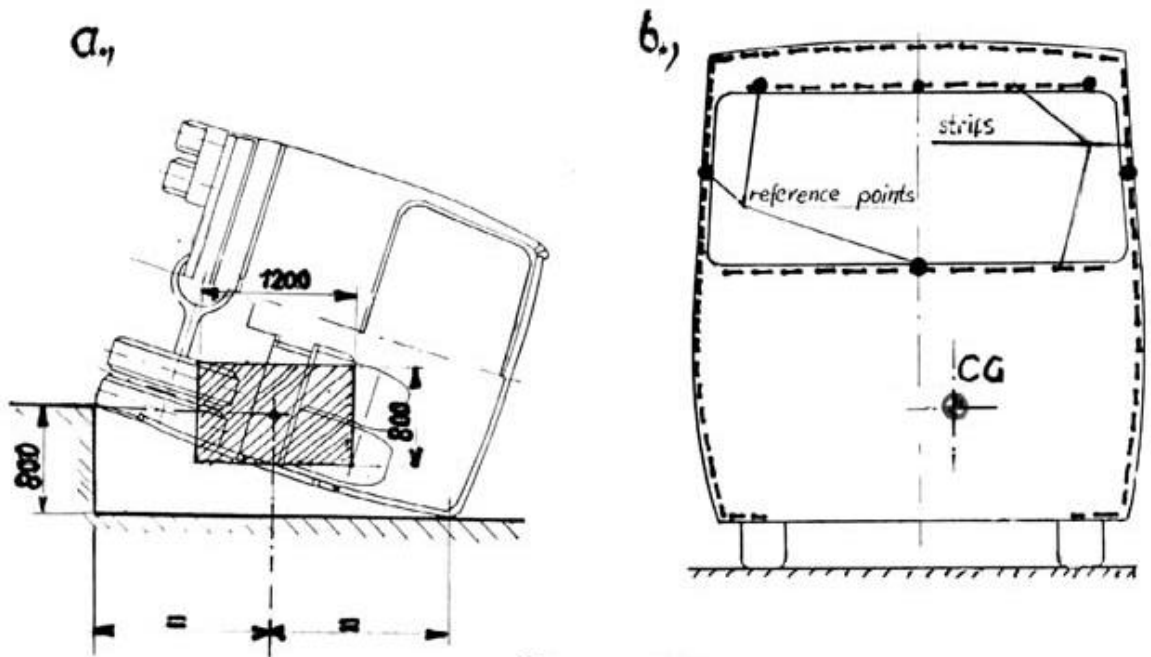

Figure A2.

Annex 5, Appendix 1

THE ROLLOVER TEST AS A TIME-DEPENDENT DYNAMIC PROCESS

1. The rollover test as a time process can be described by different stages belonging to certain moments or time ranges. In every stage at least the following characteristics shall be considered:
 - the motion of the vehicle, as a rigid body or rigid parts of the deformable superstructure (kinematics)
 - the acting and reacting (supporting) dynamic forces on the vehicle (kinetics)
 - the energy balance, considering all kinds of energies and mechanical works belonging to the process
 - deformation process related to the operation of plastic zones and plastic hinges

2. The following main stages of the rollover process may be determined and distinguished
 - (a) Starting position ($t=0$).
Unstable situation, the vehicle is standing on its one-side wheels, no motion. The centre of gravity is in the highest position which represents a certain potential energy (see figure A/A1-a).
 - (b) Rigid body-like rotation ($0 < t < t_1$).
Rollover around the longitudinal axis (O_1) determined by the wheel supporting points. The lower and upper part of the vehicle is moving together. The force of gravitation generates increasing angular velocity, the height of centre of gravity is decreasing, the potential energy is transformed into kinetic energy.
 - (c) Cantrail collision with the ground (t_1).
The vehicle hits the ground, new dynamic supporting (reaction) force is built up alongside the cantrail (O_2) where local deformation occurs, and the ground also absorbs certain energy. The motion of the roof (upper part of the vehicle) is slowed down (see figure A/A1-c).
 - (d) Main structural deformation ($t_1 < t < t_2$).
There is no more rigid body like motion. The lower and upper part of the vehicle behave differently. The plastic zones and hinges are working, producing large scale plastic deformation and distortion of the upper part. The lower part continues the rotation around the axis (O_1). The centre of gravity's height is decreasing which creates further kinetic energy. Supporting forces are acting at (O_1) and (O_2). The cantrail slides on the ground which absorbs a certain amount of kinetic energy as friction work.

- (e) Waistrail collision with the ground (t_2).
If the superstructure is not so strong that the structural deformation stops in the previous stage, the waistrail also hits the ground, where some local deformations may occur. The upper part of the vehicle is almost stopped in motion. A new dynamic supporting force is created at the waistrail (O_3) while the supporting force at (O_1) is decreasing to zero (see figure A/A1-e).
- (f) Additional structural deformation ($t_2 < t < t_3$).
The plastic hinges work further, the deformation of the upper part of the superstructure is continuing. The lower rigid part of the vehicle continues the rotation, but around a new axis (O_3) and the centre of gravity can go upwards. Dynamic mass forces are acting having horizontal components which can cause the sliding of the vehicle on the ground, friction work absorbs energy.
- (g) Critical structural deformation (t_3).
The mass and reaction forces cannot overcome the resistance of plastic hinges anymore, the plastic hinges stop working. This is the moment of the critical (maximum) deformation containing both elastic and plastic deformations. This is the moment in which the requirement of the unharmed residual space shall be checked and proved. This is also an unstable position of the vehicle in respect of its motion (see figure A/A1-g).
- (h) End of the structural deformation (t_4).
The elastic deformations spring back, only the permanent deformations remain in the structure. The structural deformation, the danger of the residual space is smaller in the moment t_4 than in t_3 .
- (i) Further motion of the vehicle ($t_4 < t < t_5$).
The motion of the vehicle in this phase is rigid-body-like again. This is a swinging rotation around the axis (O_3) until the final stable position of the vehicle. The kinetic energy is absorbed by friction work, local deformations and by other energy dissipation. This phase of the rollover process is not significant from the point of view of approval, but it has a great importance in the energy balance of the rollover process.
- (j) End position (t_5) Stable position.
The whole vehicle with the deformed superstructure - and all its parts and components - rests upon the ground of the ditch, no more motion, the centre of gravity of the vehicle is in its lowest position.

3. The energy balance of the rollover process is shown on figure A/A2. This is also a time dependent process, and studying it at least the following components shall be considered:

- potential energy (E_p) determined by the mass and centre of gravity's height of the vehicle as a rigid body or rigid parts of the deformable superstructure,

- kinetic energy (E_k) determined by the mass and (angular) velocity of the vehicle as a rigid body or rigid parts of the deformable superstructure,
- deformation work (W_{ph}) as the result of the operation of plastic zones and hinges, including plastic and elastic deformations too,
- energy absorbed by local deformations (W_1) due to the small local deformations, fractures in the structures, which does not influence the main deformation and distortion of the superstructure, does not endanger the residual space,
- friction work (W_s) due to the slips of the vehicle on the ground surface of the ditch in different stages of the process,
- energy absorbed by the ground (W_g) deformation and oscillation when the vehicle hits, contacts the horizontal surface of the ditch,
- energy dissipation (W_0) by sound, by oscillation of the parts, components of the vehicle, etc.

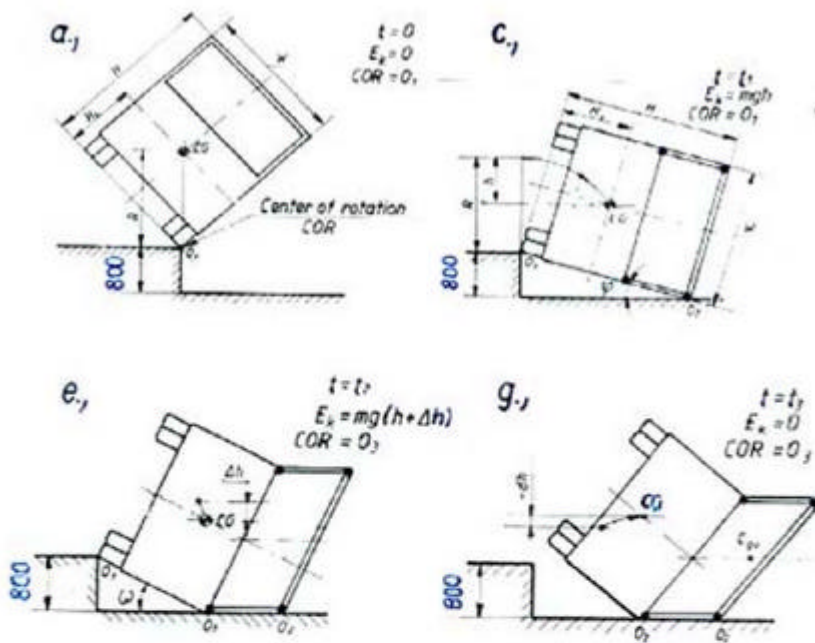

Figure A/A1.

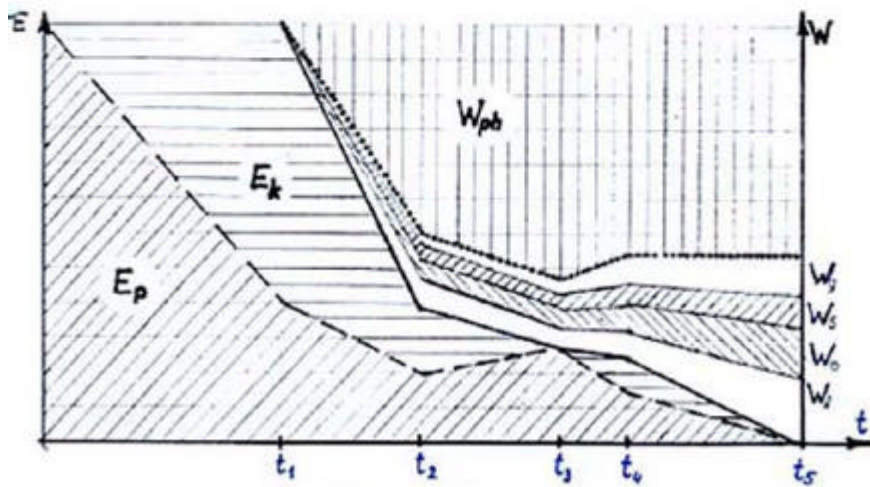

Figure A/A2.