

Distr.
GENERAL

TRANS/WP.29/GRRF/1998/19/Rev.3
4 July 2001

ENGLISH ONLY

ECONOMIC COMMISSION FOR EUROPE

INLAND TRANSPORT COMMITTEE

World Forum for Harmonization of Vehicle Regulations (WP.29)

Working Party on Brakes and Running Gear (GRRF)
(Fiftieth session, 10 - 13 September 2001,
agenda item 7.1.)

PROPOSAL FOR A NEW DRAFT REGULATION:

UNIFORM PROVISIONS CONCERNING THE APPROVAL OF WHEELS
FOR PASSENGER CARS AND THEIR TRAILERS

Revision 3

Transmitted by the Expert from Italy

Note: The text reproduced below was prepared by the expert from Italy in order to update the provisions for wheels used in motor vehicles and in their trailers (TRANS/WP.29/GRRF/49, para. 75). It includes into its part II the prescriptions for their installation on the vehicles.

Note: This document is distributed to the Experts on Brakes and Running Gear only.

GE.01-

1. SCOPE

This Regulation covers new wheels designed for vehicles in categories M1, M1G, O1 and O2 1/.

It does not apply to wheels supplied as original equipment by the vehicle manufacturer.

This Regulation consists of the following parts:

- Part I: Wheel specific requirements
- Part II: Installation of the wheels on vehicles

PART I - WHEEL SPECIFIC REQUIREMENTS

2. DEFINITIONS

For the purpose of this Regulation:

2.1 "Wheel" means a rotating load-carrying member between the tyre and the axle. It usually consists of two major parts:

- (a) the rim;
- (b) the wheel disc.

The rim and wheel disc may be integral, permanently attached, or detachable.

2.1.1. "Disc wheel" means a permanent combination of a rim and wheel disc.

2.1.2. "Wheel with demountable rim" means a wheel so constructed that the demountable rim is clamped to the wheel disc.

2.1.3. "Rim" means that part of the wheel on which the tyre is mounted and supported.

2.1.4. "Wheel disc" means that part of the wheel which is the supporting member between the axle and the rim.

2.2. "Wheel type" means a wheel which does not differ in the following essential characteristics:

- 2.2.1. the wheel manufacturer
- 2.2.2. wheel size designation
- 2.2.3. construction materials
- 2.2.4. wheel attachment holes
- 2.2.5. maximum load capacity
- 2.2.6. recommended maximum inflation pressure
- 2.2.7. method of production (welded, forged, cast,...)

2.3. "OE-wheels" means wheels which are covered by vehicle type approval

1/Categories M and O as defined in annex 7 to the Consolidated Resolution on the Construction of Vehicles (R.E.3) (document TRANS/WP.29/78/Rev.1/Amend.2)

- 2.4. "Identical wheels" means wheels which are not OE-wheels:
- wheels which are manufactured using the same manufacturing equipment as that used for wheels fitted by the vehicle manufacturer during series production. They differ from OE-wheels only by the absence of trademarks and/or the part number of the vehicle manufacturer and additional identification signs, or
- wheels which are replicas of the wheels fitted during series production and approved with the vehicle type approval. With regard to the design (contour, dimensions, material quality and thickness) they fully correspond to the wheels fitted in series production. The service life shall be same as the OE wheel or as required by this regulation.
- 2.5. "Special wheels" means:
wheels which are not OE-wheels and which do not fulfil the criteria for identical wheels. Provided they comply with the requirements of this regulation (part I and II), they may be used on a vehicle.
- 2.6. "Inset" means the distance from the attachment face of the disc to the centre line of the rim (see part I, figure 1).
- 2.7. "Dynamic radius" means the dynamic loaded radius defined as the theoretical rolling circumference divided by 2π of the largest tyre to be used on the wheel as specified by the wheel manufacturer.
- 2.8. "Designated Technical Service" means a Technical Service designated by National Authorities.
- 2.9. "International Tyre and Rim Standards" mean documents concerning wheel standardization issued by the following Organizations:
- (a) The International Organization for Standardization (ISO) 2/;
 - (b) The European Tyre and Rim Technical Organization (ETRTO) 3/:
"Standards Manual";
 - (c) The European Tyre and Rim Technical Organization (ETRTO) 3/:
"Engineering Design Information - obsolete data";
 - (d) The Tyre and Rim Association Inc. (TRA) 4/:
"Year Book";
 - (e) The Japan Automobile Tyre Manufacturers Association (JATMA) 5/:
"Year Book";
 - (f) The Tyre and Rim Association of Australia (TRAA) 6/:
"Standard Manual";
 - (g) The Associacao Brasileira de Pneus e Aros (ABPA) 7/:
"Manual de Normal Tecnicas";
 - (h) The Scandinavian Tyre and Rim Organisation (STRO) 8/:
"Data Book"

The tyre standards can be obtained from the following addresses:

2/ ISO, 1, rue de Varembe, Case postale 56, CH-1211 Genève 20 - Switzerland

3/ ETRTO, 32 Av. Brugmann - Bte 2, B-1060 Brussels, Belgium

4/ TRA, 175 Montrose West Avenue, Suite 150, Copley, Ohio, 44321 USA

5/ JATMA, NO.33 MORI BLDG. 8th Floor 3-8-21, Toranomon Minato-Ku, Tokio 105-0001, Japan

6/ TRAA, Suite 1, Hawthorn House, 795 Glenferrie Road, Hawthorn, Victoria, 3122 Australia

7/ ABPA, Avenida Paulista 244-12º Andar, CEP, 01310 Sao Paulo, SP Brazil

8/ STRO, Älggatan 48 A, Nb, S-216 15 Malmö, Sweden

- 2.10. "Technical crack" is a material separation with a propagation of more than 1 mm occurring during a dynamic test (defects caused by the production process are not to be taken into account).
- 2.11. "Wheel caliper" is the rotating profile shape, formed by the internal wheel contour (see part II, figure 1).
3. APPLICATION FOR APPROVAL
- 3.1. The application for approval of a wheel type shall be submitted by the manufacturer, or by his duly accredited representative, and shall be accompanied by:
- 3.1.1. Drawings, in triplicate, sufficiently detailed to permit identification of the type. They shall also show the position intended for the approval mark and for the wheel markings;
- 3.1.2. Technical description including at least the following characteristics:
- 3.1.2.1. rim contour designation - wheel inset - wheel attachment details;
- 3.1.2.2. tightening torque for studs and nuts;
- 3.1.2.3. fixing method of balancing weights;
- 3.1.2.5. necessary accessories (i.e. additional mounting components);
- 3.1.2.6. International Standard reference;
- 3.1.2.7. suitable for tubeless tyre mounting;
- 3.1.2.8. suitable valves types;
- 3.1.2.9. maximum load capacity;
- 3.1.2.10. maximum inflation pressure.
- 3.1.3. Sample wheels representative of the wheel type necessary for the execution of laboratory tests or test reports issued by a designated Technical Service.
4. APPROVAL
- 4.1. If the wheel submitted for approval in accordance with paragraph 3. above meets the requirements of both part I and part II of this regulation, part I and part II, then approval for this type of wheel shall be granted.
- 4.2. An approval number shall be assigned to each type approved. The approval number shall start with an "I" indicating that the ECE approved wheel is an identical wheel or an "S" indicating that the wheel is an ECE-Approved Special wheel. The next two digits (at present 00 for the regulation in its original form) shall indicate the series of amendments incorporating the most recent major technical amendments made to the Regulation at the time of issue of the approval. The same contracting party may not assign the same number to another type of wheel.
- 4.3. Notice of approval or refusal or extension of approval of a type of wheel under this regulation shall be communicated to the parties to the 1958 Agreement which apply this regulation by means of a communication form conforming to the model in annex 1 to this Regulation.

- 4.4. Every wheel conforming to a type approved under this regulation shall bear, in addition to the markings prescribed in paragraph 5., a clearly legible and indelible international approval mark consisting of:
- 4.4.1. A circle surrounding the letter E followed by the distinguishing number of the country which has granted approval (see annex 2). 9/
- 4.4.2. The number of this regulation, followed by the letter R, a dash and the approval number according to paragraph 4.2.
- 4.5. The approval mark shall be permanent, visible and clearly legible, when the tyre is fitted on the wheel.
- 4.6. Annex 2 to this regulation gives an example of the arrangement of the approval mark.
5. WHEEL MARKINGS
- 5.1. The wheel shall be permanently and legibly marked as follows, in a position chosen by the manufacturer, but visible when the tyre is fitted on the wheel:
- 5.1.1. manufacturer name or trade mark;
- 5.1.2. the wheel or rim contour designation;
- 5.1.2.1. it shall be expressed according to the prescription of one International Tyre and Rim Standards and includes at least:
- 5.1.2.1.1. Rim size designation comprising:
rim contour designation
nominal rim diameter
the symbol "x" if one piece rim
the symbol "-" if multipiece rim
letter "A" if the well is located asymmetrically optional
the letter "S" if the well is located symmetrically optional

9/ 1 for Germany, 2 for France, 3 for Italy, 4 for Netherlands, 5 for Sweden, 6 for Belgium, 7 for Hungary, 8 for the Czech Republic, 9 for Spain, 10 for Yugoslavia, 11 for the United Kingdom, 12 Austria, 13 for Luxembourg, 14 for Switzerland, 15 (vacant), 16 for Norway, 17 for Finland, 18 for Denmark, 19 for Romania, 20 for Poland, 21 for Portugal, 22 for the Russian Federation, 23 for Greece, 24 for Ireland, 25 for Croatia, 26 for Slovenia, 27 for Slovakia, 28 for Belarus, 29 for Estonia, 30 (vacant), 31 for Bosnia and Herzegovina, 32 for Latvia, 33 (vacant), 34 for Bulgaria, 35-36 (vacant), 37 for Turkey, 38-39 (vacant), 40 for The former Yugoslav Republic of Macedonia, 41 (vacant), 42 for the European Community (Approvals are granted by its member States using their respective ECE symbol), 43 for Japan, 44 (vacant), 45 for Australia, and 46 for Ukraine. Subsequent numbers shall be assigned to other countries in the chronological order in which they ratify or accede to the Agreement Concerning the Adoption of Uniform Technical Prescriptions for Wheeled Vehicles, Equipment and Parts which can be Fitted and/or be Used on Wheeled Vehicles and the Conditions for Reciprocal Recognition of Approval Granted on the Basis of these Prescriptions, and the numbers thus assigned shall be communicated by the Secretary-General of the United Nations to the Contracting Parties to the Agreement.

- 5.1.3. the wheel inset;
- 5.1.4. date of manufacture(at least the month and year);
- 5.1.5. the wheel/rim part number;
- 5.2. Annex 3 to this regulation gives an example of the arrangement of the wheel markings.
- 6. GENERAL REQUIREMENTS
- 6.1. Rim contour shall conform to the International Standard specified by the wheel manufacturer.
- 6.2. Rim contour shall ensure the correct fitting of tyres and valves.
- 6.2.1. Wheels designed for use with tubeless tyres shall ensure air retention.
- 6.3. Materials used for the construction of the wheel shall be analysed according to annex 4.
- 6.4. The wheels shall satisfy the following tests without showing any fault:
 - 6.4.1. Steel wheels
 - 6.4.1.1. Disc wheels
 - (a) Rotating bending test as per annex 6;
 - (b) Rolling test as per annex 7.
 - 6.4.2. Aluminium alloy wheels
 - 6.4.2.1. One piece wheels
 - (a) Corrosion test as per annex 5. If the process within a production line is always the same, only one representative test is to be carried out.
 - (b) Rotating bending test as per annex 6;
 - (c) Rolling test as per annex 7.
In the case of significant reduction or variation in rim thickness the technical service may require more than one test
The thinning or the minimum thickness should be defined.
Maybe 3.5 mm min. thickness as a test criteria
 - (d) Impact test as per annex 8.
 - (e) Alternating torque test as per annex 9. This test is only necessary if the wheel design has a small cross section area between spoke and rim and a small number of spokes.
 - 6.4.2.2. Demountable rim wheels
 - (a) Rotating bending test as per annex 6;
 - (b) Rolling test as per annex 7;
 - (c) Impact test as per annex 8;
 - (d) Alternating torque test as per annex 9.

- 6.4.3. Magnesium alloy wheels
- 6.4.3.1. One piece wheels
- Corrosion test as per annex 5;
- (b) Rotating bending test as per annex 6;
 - (c) Rolling test as per annex 7;
 - (d) Impact test as per annex 8.
 - (e) Alternating torque test as per annex 9. This test is only necessary if the wheel design has a small cross section area between spoke and rim and a small number of spokes.
- 6.4.3.2. Demountable rim wheels
- (a) Corrosion test as per annex 5;
 - (b) Rotating bending test as per annex 6;
 - (c) Rolling test as per annex 7;
 - (d) Impact test as per annex 8;
 - (e) Alternating torque test as per annex 9.
- 6.5. Alternative test procedures to those described in annexes 5 to 9 are allowed if their equivalence can be demonstrated.
- 6.6. Where a wheel manufacturer submits application for type approval for a range of wheels, it is not considered necessary to carry out all tests on every type of wheels in the range. Worst-case selection may be made at the discretion of the designated Technical Service.
7. MODIFICATIONS AND EXTENSION OF APPROVAL FOR WHEEL
- 7.1. Every modification 10/ of the wheel type shall be notified to the approval authority which granted the type approval. The approval authority may then:
- 7.1.1. either consider that the modifications made are unlikely to have appreciable adverse effects and that in any case the type of wheel still complies with the requirements;
 - 7.1.2. or require a further test report from the Technical Service responsible for conducting the tests.
- 7.2. Confirmation or refusal of approval, specifying the alterations, shall be notified by the procedure specified in paragraph 4.3. above to the parties to the agreement applying this regulation.
- 7.3. The competent authority issuing the extension of approval shall assign a series number to each communication form drawn up for such an extension.

10/ In case of minor changes which have no influence on the fatigue or fit and function, such modifications can be announced and solved by a letter of no concern.

8. CONFORMITY OF PRODUCTION

8.1. The conformity of production procedures shall comply with those set out in the agreement - E/ECE/324-E/ECE/TRANS/505/Rev.2 appendix 2.

8.2. The authority which has granted type approval may at any time verify the conformity control methods applied in each production facility. The normal frequency of these verifications shall be once every two years.

9. PENALTIES FOR NON-CONFORMITY OF PRODUCTION

9.1. The approval granted in respect of a type of wheel pursuant to this regulation may be withdrawn if the requirements set forth above are not met or if a wheel bearing the approval mark does not conform to the type approved.

9.2. If a contracting party to the agreement applying this regulation withdraws an approval it has previously granted, it shall forthwith so notify the other contracting parties applying this regulation, by means of a communication form conforming to the model in annex 1 to this regulation.

10. PRODUCTION DEFINITELY DISCONTINUED

If the holder of an approval completely ceases to manufacture a wheel approved in accordance with this regulation, he shall so inform the authority which granted the approval. Upon receiving the relevant communication, that authority shall inform the other parties applying this regulation by means of a communication form conforming to the model in annex 1 to this Regulation.

11. SIMPLIFIED TESTING AND APPROVAL PROCEDURE

If the wheel manufacturer's test equipment and applied procedures are approved by designated Technical Service, the execution of laboratory tests required by this Regulation (part I) and positive test results shall be accepted by designated Technical Service.

As an alternative to the tests indicated in the present regulation the fatigue strength can be proved by a comparison test with OE wheel. As a further alternative the test specification for OE-wheels of the car manufacturer can also be used.

12. NAMES AND ADDRESSES OF TECHNICAL SERVICES RESPONSIBLE FOR CONDUCTING APPROVAL TESTS AND OF ADMINISTRATIVE DEPARTMENTS

The contracting parties to the agreement applying the regulation shall communicate to the United Nations secretariat the names and addresses of the Technical Services responsible for conducting approval tests and of the administrative departments which grant approval and to which forms certifying approval or extension or refusal or withdrawal of approval, or production definitely discontinued issued in other countries, are to be sent.

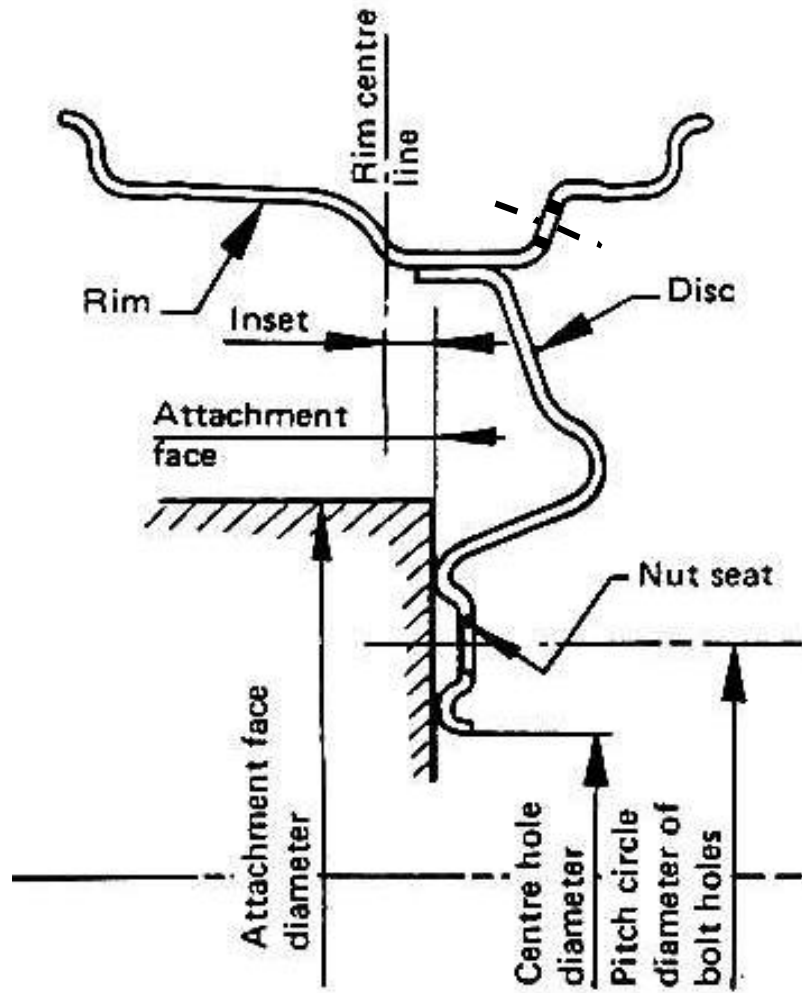

Figure 1

Annex 1

COMMUNICATION

(Maximum format: A4(210 x 297 mm))



issued by: Name of administration:
.....
.....
.....

concerning: 2/

- APPROVAL GRANTED
- APPROVAL EXTENDED
- APPROVAL REFUSED
- APPROVAL WITHDRAWN
- PRODUCTION DEFINITELY DISCONTINUED

of a wheel type, pursuant to Regulation No. ...
Approval No.

Extension No.

1. Wheel manufacturer:
2. Wheel type designation:
 - 2.1. Construction material:
 - 2.2. Method of production:
 - 2.3. Rim contour designation:
 - 2.4. Wheel inset:
 - 2.5. Wheel attachment:
 - 2.6. Maximum load capacity
3. Address of the manufacturer:
4. If applicable, name and address of manufacturers representative.
5. Date on which the wheel was submitted for approval tests:
6. Technical Service responsible for carrying out the approval test:
7. Date of test report issued by the Technical Service:
8. Number of test report issued by the Technical Service:
9. Remarks:
10. Approval granted/refused/extended/withdrawn 2/
11. Reason(s) for the extension (if applicable):
12. Place:
13. Date:
14. Signature:
Name:
15. Annexed is a list of documents making up the approval file, deposited with the competent authority which granted approval, a copy can be obtained on request.

1/ Name of the administration.

2/ Strike out what does not apply.

Annex 2

ARRANGEMENT OF THE APPROVAL MARK



a) Identical

The wheel bearing the above approval mark is an Identical wheel that has been approved in Italy (E3) under approval number 001148.



b) Special wheel

The wheel bearing the above approval mark is a Special wheel that has been approved in Italy (E3) under approval number 001148.

The first two digits of the approval number indicate that the approval was granted in accordance with the requirements of Regulation No. XY in its original form.

The marking of approval mark, Regulation No. and approval number may be at a distance from each other respecting the sequence.

Annex 3

ARRANGEMENT OF THE WHEEL MARKINGS

Example of markings which shall be applied to a wheel conforming to this Regulation:

ABCDE 5 ½ J x 14 FH 36 01 99 ab123

This example of marking defines a wheel:

manufactured by ABCDE
having a rim contour designation (5½ J)
having a one piece construction(x)
having a nominal rim diameter code (14)
having a non symmetrical location of the well (no mark)
having a flat hump configuration of the bead-seat area on one side only (FH) - optional marking
having a wheel inset of 36 mm
manufactured in January 1999 (0199)
the manufacturer's part number (ab123)

the rim designation shall include in the following order the rim contour designation, the construction, the nominal rim diameter code, the location of the well and the bead-seat configuration, as in the example 5½ J x 14 FH. It is also permitted to reverse the order for the first three elements as in the example 14 x 5½ J FH.

The marking of the wheel inset, the date of production and manufacturer's name may be at a distance from the rim designation.

Annex 4

MATERIAL TEST

The following metallurgical analysis shall carried out and reported:

Material	Tests
Aluminium alloy	a, c, e
Magnesium alloy	a, c, e
Steel	a, b, d

- (a) Chemical analysis of the raw-material.
- (b) Check of the following mechanical characteristics ($R_{p0,2}$, R_m , and A) relevant to the materials:
- percentage elongation after fracture (A) : Permanent elongation of the gauge length after fracture ($L_u - L_o$), expressed as a percentage of the original length (L_o).
- Where
- original gauge length (L_o) : Gauge length before application of force.
- final gauge length (L_u) : Gauge length after rupture of the test piece.
- proof strength, non-proportional extension (R_p) : Stress at which a non-proportional extension is equal to a specified percentage of the extensometer gauge length (L_e). The symbol used is followed by a suffix giving the prescribed percentage of the extensometer gauge length, for example: $R_{p0,2}$.
 - tensile strength (R_m) : Stress corresponding to the maximum force (F_m).
- (c) Check of the mechanical characteristics ($R_{p0,2}$, R_m , and A) of test-pieces taken from the hub mounting area and in the disc to rim transition area or in the failure zone if any.
- (d) Analysis of the metallurgic defects and of the raw material structure.
- (e) Analysis of the metallurgic defects and of the test-pieces structure taken from the hub mounting area and in the disc to rim transition area or in the failure zone if any.
-

Annex 5

CORROSION TEST

1. Carry out a salt-spray test as per ISO 9227 for 384 hours.

1.1. Sample preparation

A surface treated sample, taken from production, shall be damaged by cross engraving and stone impact (ISO 565) to represent damaging situations during the normal usage of vehicle (damage shall be in the area of the rim flange and inside the wheel).

1.2. Test development

The surface treated sample shall pass a salt-spray test, in which the sample and any components with which is normally in contact are put in upright position into the salt-spray test equipment. The wheel is turned through 90° every 48 hours.

1.3. Evaluation

Individual measures which may affect the corrosion are to be evaluated (covers, creeps, zinc or cadmium buses, alloy insulating covers etc.)

The test documentation shall include photos showing the main corrosion points which have been mechanically washed in order to show the material defects.

There shall not be any significant corrosion after a test duration of 192 hours. After 384 hours the wheel functionality, the mounting components and the tyre bead seat shall not be adversely affected by corrosion. This shall be confirmed by a rotating bending test as per annex 6 or by a rolling test as per annex 7, depending on the location of the corrosion.

Annex 6

ROTATING BENDING TEST

1. Test Description

During the rotating bending test, the lateral forces acting on wheel in driving around a curve are simulated. Four wheel samples shall be tested, two at 50% and two at 75% of the maximum side force. The wheel rim is fixed rigidly to the test bench, and a bending moment M_b is applied to the hub mounting area (i.e. through a loading arm with a flange having the same pitch circle diameter as the vehicle for which the wheel is intended). Light alloy wheels are fixed using the internal rim flange by two semicircular flanges.

Should other fixing devices be used, it is necessary prove their equivalence.

Screws or fixing nuts are tightened to the torque stated by the vehicle manufacturer and retightened after 10,000 cycles approximately.

2. Formula for the bending moment calculation

Cars and off-road vehicles :
$$M_{bmax} = S * F_v * (\mu * r_{dyn} + d)$$

- M_{bmax} = maximum reference bending moment [Nm]
- F_v = maximum load capacity of wheel [N]
- r_{dyn} = dynamic radius of largest tyre recommended for wheel [m]
- d = inset [m]
- μ = coefficient of friction
- S = factor of safety

3. The test is carried out with two percentage values (50 per cent and 75 per cent) of the max moment and on the basis of the following standards

Coefficient of friction	0.9
Factor of safety	2.0
Nominal cycles per minute	The number of cycles per minute can be the maximum possible but outside the testing rig resonance frequency.

Vehicle category	Aluminium / Magnesium		Steel	
	M1 and M1G	O1 and O2	M1 and M1G	O1 and O2
Min cycles with 75 per cent M_{bmax}	$2.0 \cdot 10^5$	$0.66 \cdot 10^5$	$6.0 \cdot 10^4$	$2.0 \cdot 10^4$
Min cycles with 50 per cent M_{bmax}	$1.8 \cdot 10^6$	$0.69 \cdot 10^6$	$6.0 \cdot 10^5$	$2.3 \cdot 10^5$
Acceptance limits	Shaft displacement less than 10 per cent greater than the displacement measured after approximately 10,000 cycles.			
	Technical cracks are not accepted.		-	
Allowable loss of tightening torque initially applied to the wheel fixing studs and nuts ^{1/}	Maximum 30 per cent			

4. Test schedule for range of wheel types

Wheels of the same type (paragraph 2.2.) but with different inset values can be grouped using the highest value of test bending moment according to the following test schedule. Wheel versions having a larger centre hole shall be included in the test. In the case of a failure further samples shall be tested.

Necessary tests:

number of wheels to be tested	Rotating bending test	
	Short test	Long test
Minimum PCD	1	1
Maximum PCD	1	1
if only one PCD	2	2
Inset variations up to 2 mm	--	--
From 2 mm to 5 mm	1	--
> 5 mm	1	1

Tests to be carried out should the maximum permitted wheel load subsequently increase

If the resulting test bending moment increases up to 10 per cent max.	1	1
---	---	---

Short test = rotating bending test with 75 per cent of $1 M_{bmax}$
(calculated for the max wheel load)

Long test = rotating bending test with 50 per cent of M_{bmax}

Should the testing moment be increased of more of 10 per cent, when compared to the first approval, the whole programme shall be repeated.

^{1/} check loss of tightening torque of wheel fixings by retightening, not by measuring torque to loosen fixings.

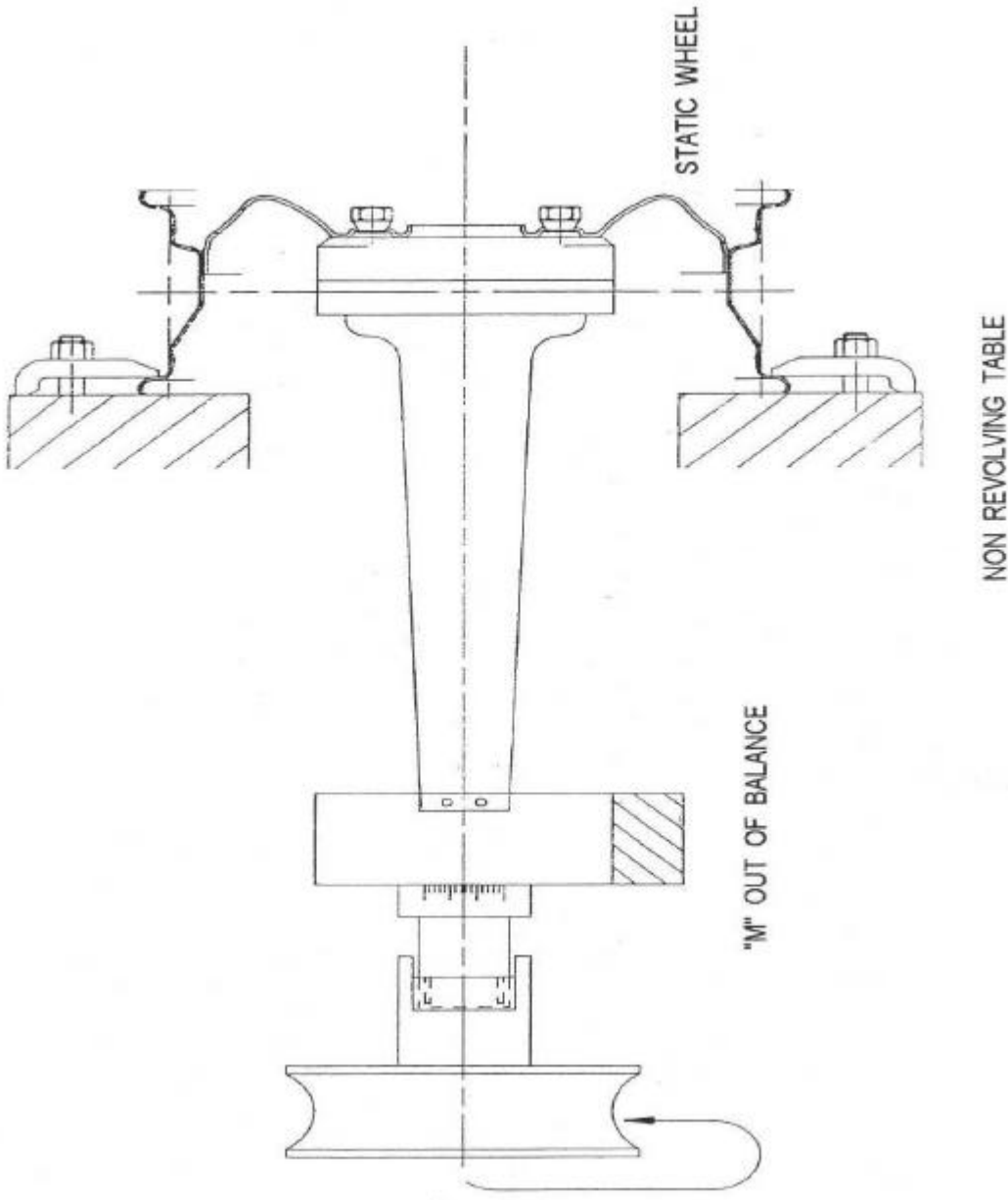

Example of a rotating bending test rig.

Annex 7

ROLLING TEST

1. Test Description

In the rolling test the stress on the wheel when driving straight ahead is simulated by testing two wheels rolling against a drum which has a minimum outside diameter of 1.7 m, in the case of an external rolling test, or a minimum internal diameter equal to the dynamic radius of the tyre divided by 0.4 in the case of an internal rolling test.

2. Formula for calculation of the test load

All types of vehicles	$F_P = S * F_V$
-----------------------	-----------------

F_P = testing load [N]
 F_V = wheel maximum load capacity of the wheel [N]
 S = factor of safety

3. Tests Procedure and Requirements

Tests are carried out on the basis of the following specifications:

	M1 and M1G	O1 and O2
Rolling direction	Straight	
Factor of safety - S	2.5 2.25 <u>1/</u>	2.0
Tyres	Taken from normal (series) production and, if possible, of the maximum nominal section width recommended for the wheel	
Testing speed in km/h	The max allowed by the tyre given by the speed index, usually 60-100 km/hour	
Equivalent rolling distance	2,000 km 1,000 km <u>1/</u>	2,000 km
Tyre pressure at start of test (nor checked or controlled during the test)	Normal usage: Up to 1.6 bar More than 1.6 bar	rolling test pressure 2.8 bar min. 4 bar
Limits of acceptance	Increase of the loading cylinder stroke or vibration level greater than 10 per cent. Compared to the value noted after approximately 10,000 revolutions. Technical cracks and/or air leakage are not accepted.	
Allowable loss of tightening torque initially applied to the wheel fixing studs and nuts <u>2/</u>	≤ 30 per cent	

1/ for passenger cars steel disc wheels

2/ check loss of tightening torque of wheel fixings by retightening - not by measuring torque to loosen fixing.

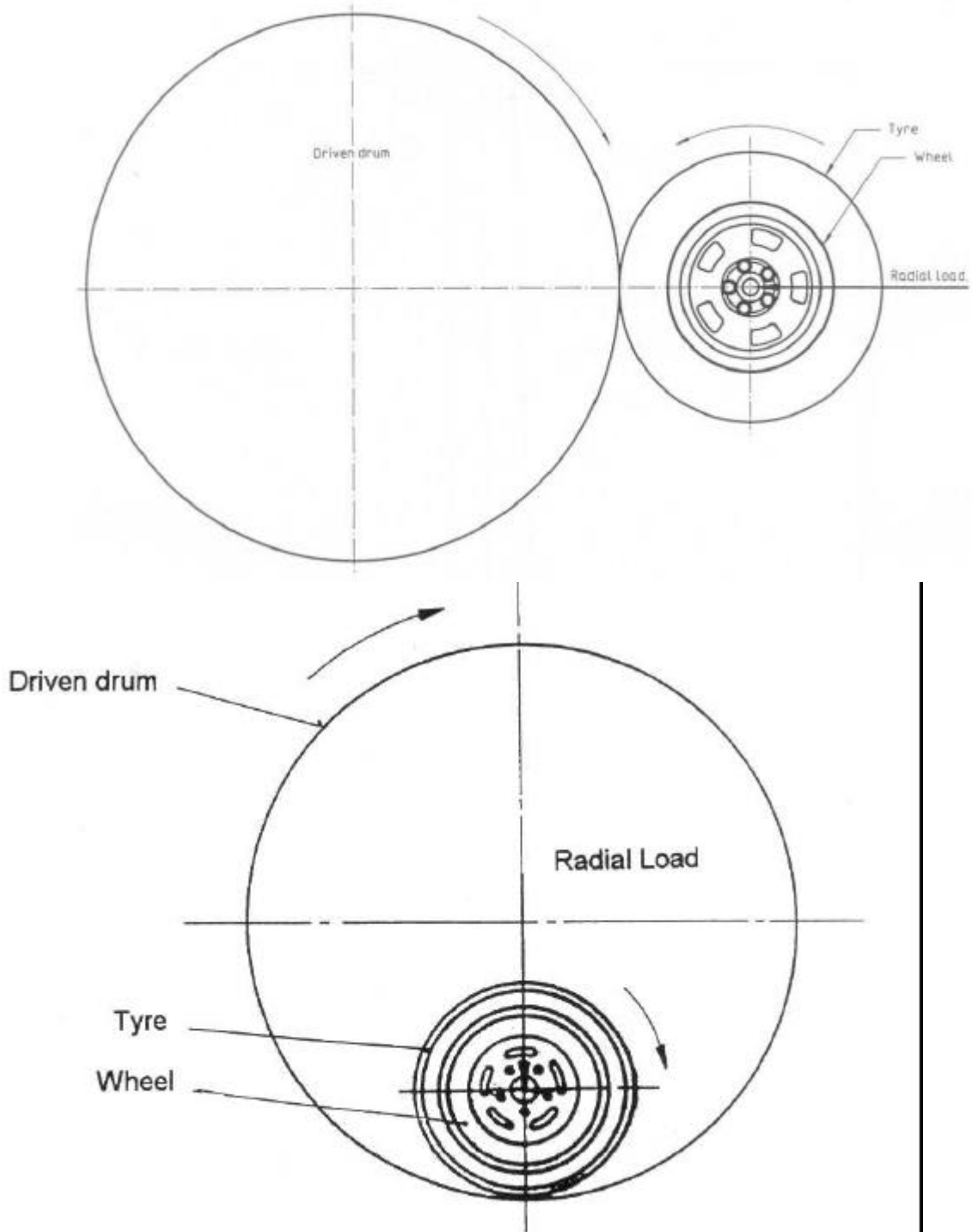

Examples of rolling test rigs.

Annex 8

IMPACT TEST

1. Test Description

Wheel strength with regard to the fractures on edges and other critical points when the wheel strikes an obstacle shall be checked. In order to show the sufficient resistance to fractures it is necessary carry out an impact test as per Annex 8 - Appendix 1.

2. Formula for the calculation of test load

$$D = 0.6 * F_v / g + 180 \text{ [kg]}$$

D = value of falling mass [kg]
 F_v = maximum wheel load capacity [N]
g = acceleration due to gravity 9.81 m/s²

3. Test Procedure and Requirements

	M1 and M1G
Procedure and requirements	As per annex 8 - appendix 1
Tyre pressure	The tyre pressure recommended by the tyre manufacturer based on the load index and the max vehicle speed, but at least 2 bar.
Tyres	Tyres taken from normal (series) production with the minimum nominal section width and minimum rolling circumference on the range of tyres recommended for the particular wheel
Acceptance criteria	The test shall be considered satisfactory if there is not any visible fracture penetrating through the wheel surface and if there is not a complete of inflation pressure within a minute of the test. Fractures and indentations caused by the direct contact with the falling weight are acceptable. In case of more piece wheels: if these screw/nut-connections fail which are close to the spoke or ventilation hole area, the test is negative
Number of samples to be tested	One for each impact position
Impact positions	One in the area connecting spokes to rim and further one in the area between two spokes, very close to the valve hole. If possible, the impact direction shall not coincide with the radial line between a fixing hole and the wheel centre.

4. Tests schedule for range of wheel types

Tests necessary:

wheels to be tested	Impact test
Minimum PCD of fixing holes	One for each impact position
Maximum PCD of fixing holes	One for each impact position
Inset differences up to 15 mm	--
> 15 mm	One for each impact position

Annex 8 - Appendix 1

PASSENGER CARS - LIGHT ALLOY WHEELS - IMPACT TEST

1. SCOPE

This annex specifies a laboratory test procedure to evaluate the axial (lateral) kerb impact collision properties of a wheel manufactured either wholly or partly of light alloys. It is intended for passenger car applications, with the purpose of screening and/or quality control of the wheel.

2. TEST EQUIPMENT

- 2.1. New wheels, fully processed, representative of wheels intended for passenger car application, fitted with a tyre.

NOTE 1: Tyres and wheels used in the tests should not be used subsequently on a vehicle.

- 2.2. Impact loading test machine with a vertically acting striker having an impacting face at least 125 mm wide and at least 375 mm long and sharp edges broken by radius or chamfer, in accordance with figure 1. The falling mass, D , within a tolerance of ± 2 per cent, expressed in kilograms, shall be as follows:

$$D = 0.6 * F_v / g + 180 \text{ [kg]}$$

where F_v / g is the maximum static wheel loading, as specified by the wheel and/or vehicle manufacturer, expressed in kilograms.

- 2.3. Mass of 1,000 kg.

3. CALIBRATION

Ensure, by means of a test calibration adapter, that the 1,000 kg mass (paragraph 2.3.) applied vertically to the centre of the wheel fixing as shown in figure 2 causes a deflection of $7.5 \text{ mm} \pm 0.75 \text{ mm}$ when measured at the centre of the beam.

4. TEST PROCEDURE

- 4.1. Mount the test wheel (paragraph 2.1.) and tyre in the test machine (paragraph 2.2.) such that the impact loading is applied to the rim flange of the wheel. The wheel shall be mounted with its axis at an angle of $13^\circ \pm 1^\circ$ to the vertical with its highest point presented to the striker.

The tyre mounted on the test wheel shall be the smallest nominal section width tubeless radial-ply tyre intended for use on that wheel. The inflation pressure shall be that specified by the vehicle manufacturer or, in the absence of such specification, it shall be 200 kPa.

The temperature of the test environment shall remain within a range of 10°C to 30°C throughout the test period.

- 4.2. Ensure that the wheel is mounted on the hub fixture with dimensionally representative fixings such as would be used on a vehicle. Manually tighten the fixings to a value or by a method as recommended by the vehicle or wheel manufacturer.

Because the design of wheel centre members may vary, test a sufficient number of locations on the wheel rim circumference to ensure that the integrity of the centre members is assessed. Use new wheels each time.

In case of test on the spoke, that spoke is to be chosen where the bolt hole is closest.

- 4.3. Ensure that the striker is over the tyre, and overlaps the rim flange by $25 \text{ mm} \pm 1 \text{ mm}$. Raise the striker to a height of $230 \text{ mm} \pm 2 \text{ mm}$ above the highest part of the rim flange and allow it to fall.

5. FAILURE CRITERIA

The wheel is considered to have failed the test if any of the following apply:

- (a) visible fracture(s) penetrate through a section of the centre member of the wheel assembly;
- (b) the centre member separates from the rim;
- (c) the tyre loses all air pressure within 1 min.

The wheel is not considered to have failed the test by deformation of the wheel assembly or by fractures in the area of the rim section struck by the face plate of the striker.

Dimensions in millimetres

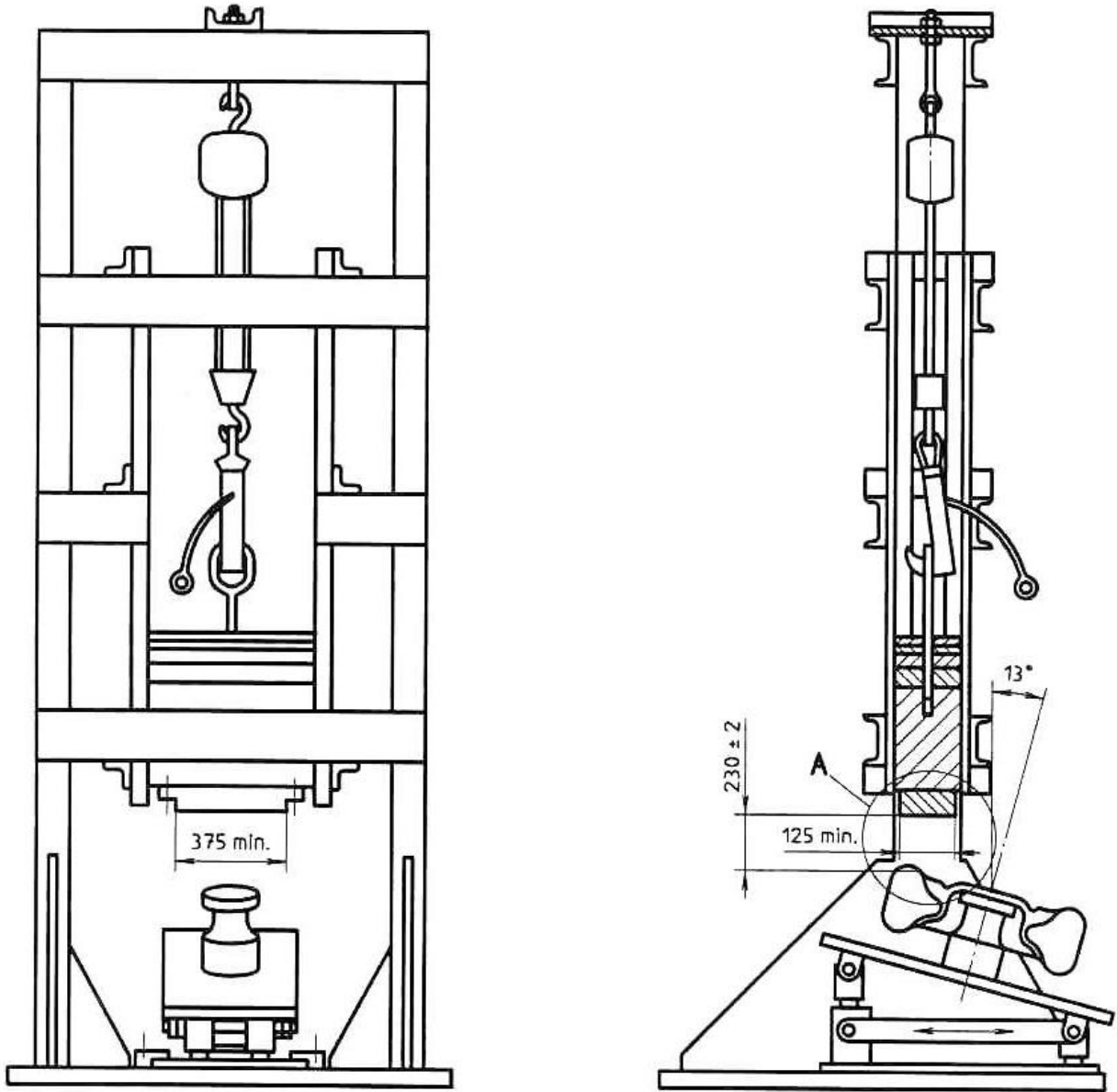

Figure 1 - Impact loading test machine

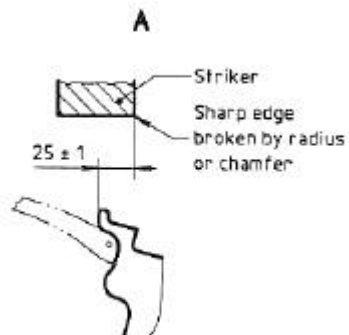

Figure 1 - Detail A

Dimensions in millimetres

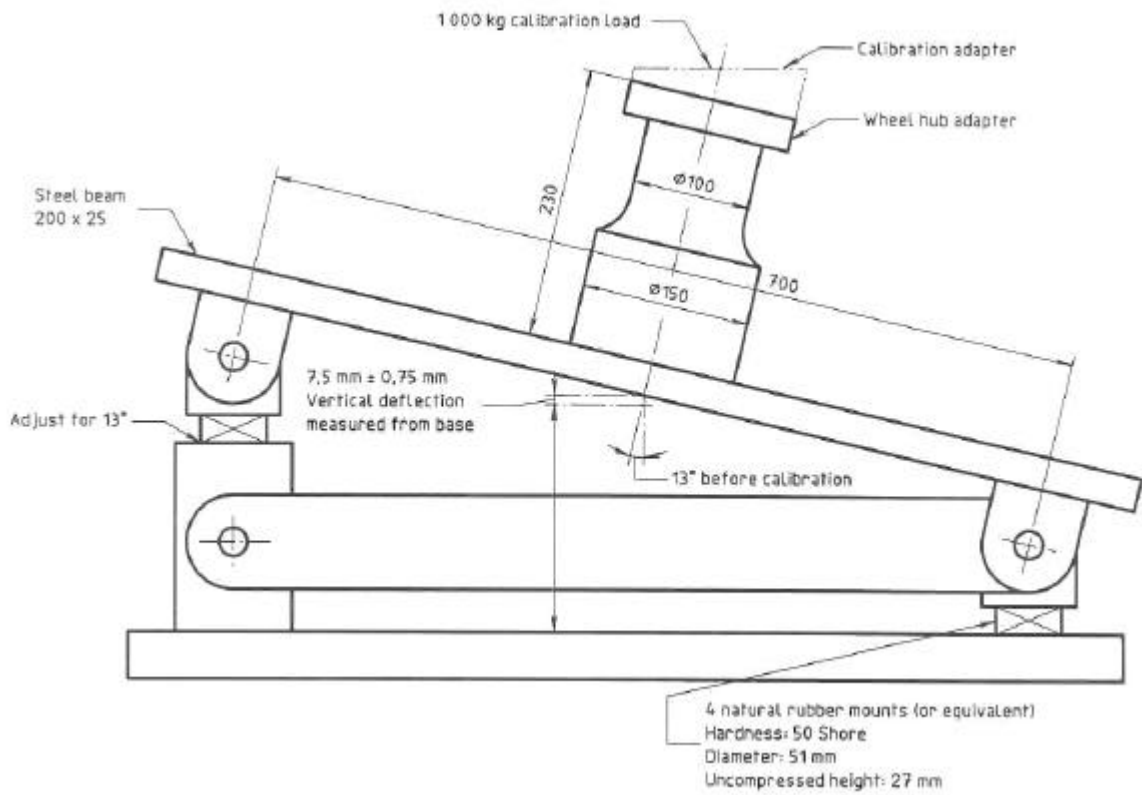

Figure 2 - Application of loading to centre of wheel mount

Annex 9

ALTERNATE TORQUE TEST

1. Test Description

In an alternating torque test the torque acting on wheel during braking and acceleration is simulated. The sample wheels shall be tested at each percentage value (50 per cent and 75 per cent) of the maximum calculated torque. Each wheel flange is rigidly fixed on the test table and stressed by an alternating torque of $\pm M_T$, introduced through the attachment face i.e. through a brake disc or through other components.

2. Formula for the calculation of the test torque

$$M_T = S * F_v * r_{dyn}$$

Where:

M_T = test torque [Nm]
 S = factor of safety
 F_v = maximum wheel load capacity [N]
 r_{dyn} = dynamic radius [m]

Tests are carried out on the basis of the following parameters:

Factor of safety S	1.0
Min number of cycles with $\pm 90\%M_T$	$2 * 10^5$
Min number of cycles with $\pm 45\%M_T$	$2 * 10^6$
Acceptance criteria	Technical cracks not acceptable
Allowable loss of the initial torque applied to wheel fixing studs and nuts <u>1/</u>	30 per cent

1/ check loss of tightening torque of wheel fixings by retightening, not by measuring torque to loosen fixing.

PART II: INSTALLATION OF THE WHEELS ON VEHICLES.

1. Scope

In principle the type approval and legality of a car for use on the road become invalid if a wheel is fitted that is not part of its type approval. For this reason it is necessary to confirm that a replacement ECE-approved wheel might be fitted, which fulfils the same legal directives, Regulations and requirements as the OE wheel without any modification to the car and fitting tool supplied.

As identical wheels by definition (definition see part I, paragraph 2.4) are the same as OE-wheels, identical wheels are, therefore, not subject to paragraph 3. "Additional requirements" of Part II: Installation of the wheels on vehicles.

With regard to special wheels (see definition Part I, paragraph 2.5), fit and function are acceptable if the paragraphs specified below are complied with.

All testing described below shall be carried out by designated technical services.

Provided that these Regulations are complied with, the legality of the vehicle for use on the road remains valid.

For all wheels, which neither correspond to the definition of an identical wheel nor to the definition of an ECE-approved special wheel, see national approval procedure.

2. General Requirements

2.1. Wheel dimensions

Nominal rim diameter, nominal rim width and nominal inset of ECE-approved wheels shall be the same as an OE-wheel within the range of the vehicle type approval.

2.2. Tyres

The tyre shall be the same as specified in the vehicle (EEC) type approval and which is fitted to the OE wheels. If a tyre is not yet available on the market or is out of production (for example a diagonal tyre), it is permissible to supply a closely corresponding specification. [Moreover, both tubeless tyres and tube type tyres are permitted. When specifying tube type tyres, the tube size shall be stated].

2.3. Field of application

The range of application is part of the approval. The tabulation shows which ECE-approved wheel can be fitted to which type of vehicle.

The following information shall be shown:

2.3.1. Wheel characteristics:

ECE approval number - wheel type - size - inset - p.c.d. - fixing holes - central spigot location - wheel variant - markings - centre hole diameter - max. wheel load

2.3.2. Vehicle characteristics:

vehicle manufacturer - vehicle model name of description - vehicle type - approval No. - power in kW - tyres.

2.3.3. Additional characteristics:

Any particular requirements specified when using OE-wheels or specific requirements for special wheel.

An example of a possible structure of a table of the above requirements is shown in annex 1 to this part.

3. Additional requirements

3.1. Wheel caliper check

The design of the inner contour of the wheel (wheel caliper, see part I, paragraph 2.11., part II figure 1) must provide sufficient space for the brake, suspension and steering components.

In the case where the wheel caliper is the same as outside the OE-wheel caliper, no verification is necessary.

In the case where the caliper is inside the OE-wheel caliper, a check shall be carried out of the wheel mounting operating clearance with respect to brake, suspension and steering components and general underbody components, taking into account the effect of wheel balance weights (see part II, additional checks, item 1, wheel caliper).

3.2. Ventilation holes check

An ECE-approved wheel shall not reduce the brake efficiency in comparison with an OE wheel. The heat transfer from the brakes into steel wheels is regarded as being more severe than that of light alloy wheels.

In the case where the OE-wheel is designed for a defined air circulation from the brake through the wheel ventilation holes to the outside (for example by "windmilling" effect) where the area of the ventilation holes in a special wheel is smaller than the corresponding OE-wheel, a comparison test between the OE-wheel and the replacement wheel shall be carried out (see part II, annex 2, additional checks, item 2, ventilation holes).

3.3. Wheel fixing

The use of OE wheel fixing components is recommended. Any special wheel fixing components shall allow fitting of the special wheel without requiring any additional change. The basic number of wheel fixings, for example 4 holes, 5 holes and so on, shall not be changed. Wheel fixings shall not foul other components, for example, brake components. Regarding wheel bolts, nuts and studs, the length

of thread engagement shall be the same as the OE. The profile of the bolts/nuts shall correspond with the profile of the fastening hole in the ECE-approved wheel. They have to fit. The material used for the wheel fixing components shall be at least equivalent to the OE.

In the case where wheel accessories are provided, adequate tools for mounting and demounting shall also be provided.

Where different wheel fixing components are supplied, they shall be stated in the application field, and the necessary fitting tools shall be provided.

3.4. Instruction leaflet

An ECE-approved special wheel shall be accompanied by an instruction leaflet which shall contain at least the following information:

tips how to fit the wheel, how to use the wheel fixing components provided and how to check the fit and function of the tyre and wheel assembly with regard to sufficient clearance for brake, suspension and steering components.

- Wheel fixing tightening torque; drawing attention to the importance of this aspect.
- Instruction regarding the necessity to re-tighten the wheel fixing after 50 km of driving.
- references to the use and mounting of hubcaps, if applicable
- vehicle application list (see part II, annex 1).

3.5. External projections

The ECE-approved wheel when fitted to the vehicle together with any necessary wheel accessories shall not create any danger. The requirements of Regulation ECE-R26 shall be respected.

3.6. Miscellaneous

The test report shall contain the details and results of the tests carried out. It shall confirm that the tested wheel meets the requirements of part II. It shall also confirm, that there are no technical objections to fitting the wheel to any of the vehicles listed in the application field and that safe fit and function are guaranteed without the need for re-test.

In the case where particular usage procedures, components or accessories have to be followed or used, they must be mentioned in the application field.

Figure 1:
Wheel inner contour including examples of inside and outside situations.

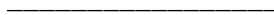
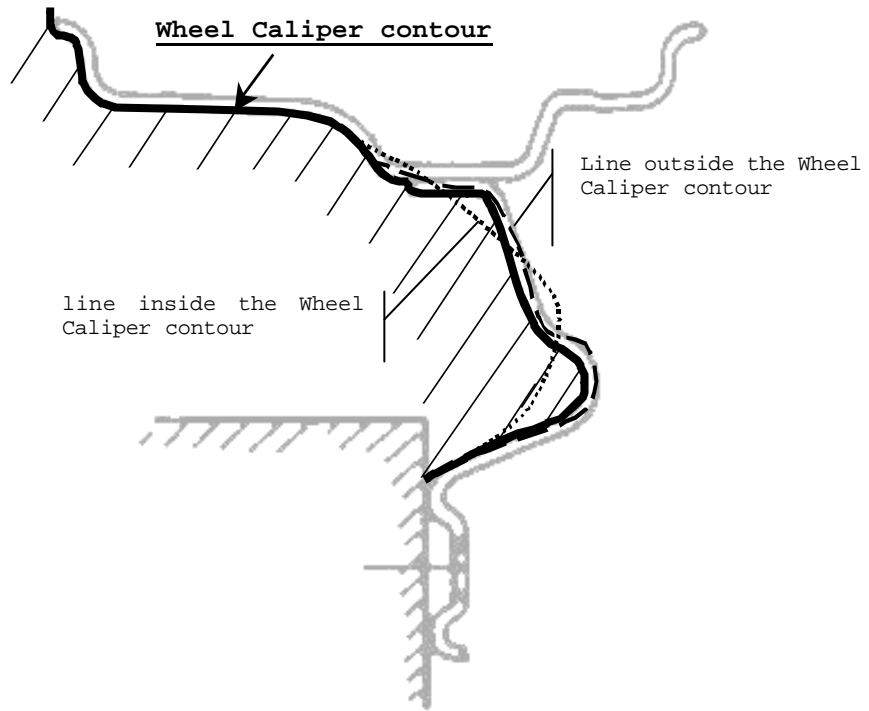

Annex 1

EXAMPLE OF A POSSIBLE STRUCTURE OF THE "FIELD OF APPLICATION"

Wheel characteristics

ECE approval number	wheel type	Size	inset	pcd	fixing holes 2/
XY R-I 0001148	6014	6Jx14H2	38 mm	98 mm	4
Control spigot location	wheel variant	Wheel marking	centre ring marking	Centre hole dia. in mm	max. wheel load in N
Yes	A	98-38	120-98	58.1	5500

Vehicles' characteristics

Vehicle manufacturers	vehicle model name	vehicle type	Approval no.	Power in kW	Tyres (1)
FIAT	ALFA ROMEO 145/146	ALFA ROMEO 930	e3*96/27*0029*	66 - 95	175/65R14 185/60R14 195/55R14-82 205/55R14-85 1/

(1) NOTE : Tyres deriving from the vehicle approval and suitable to be fitted on the above-mentioned wheel type

Additional characteristics

Ref.	Characteristic
1/	Snow chains not permitted
2/	Spherical fastening screws

Annex 2

ADDITIONAL CHECKS */

1. Wheel caliper (see point 3.1)

In the case where the wheel caliper is inside the OE-wheel caliper, there shall be sufficient clearance in under all conditions of steering and suspension travel which occur in normal driving. For that reason, tests shall be carried out in order to ensure that the wheel assembly has sufficient space in the wheel housing and does not contact any vehicle part component.

As a rule, the following criteria have to be fulfilled:
minimum clearance for brake components (worst case, for example with new brake linings): 3 mm 1/),
minimum clearance for suspension components (e. g. upper and lower suspension arms): 4 mm,
minimum clearance for steering components (e. g. track rod and steering joints): 4 mm, and
minimum clearance between balance weights and vehicle components: 2 mm

The check shall be carried out statically. Alternative methods are acceptable if the test results are. If the various clearances on the CE equipment are less than those given above, then these can be accepted for the special wheel.

2. Ventilation holes (see point 3.2)

A comparison test between an OE-wheel and a special wheel to evaluate the brake efficiency using wheels with a smaller area of ventilation holes shall follow ECE-R13, appendix 4, paragraph 1.5, Type I - Fade test procedure. The criterion is the brake temperature. The maximum temperature measured (disc, drum) in combination with the OE-wheel must not be exceeded with the ECE-approved wheel. Any hubcaps normally fitted are to take into account.

1/ Use of vehicle manufacturer brake component profiles and wheel caliper is recommended. However in-service monitoring is necessary because of possible change of brake parts and/or OE-wheel caliper during the vehicle production run.

*/ Recommended by the drafter
