



**Economic and Social
Council**

Distr.

GENERAL

TRANS/WP.29/722

3 May 2000

ENGLISH

Original: ENGLISH and
FRENCH

ECONOMIC COMMISSION FOR EUROPE

INLAND TRANSPORT COMMITTEE

World Forum for Harmonization of Vehicle Regulations (WP.29)

DRAFT SUPPLEMENT 3 TO THE 03 SERIES OF AMENDMENTS TO REGULATION No. 44

(Child restraints)

Note: The text reproduced below was adopted by the Administrative Committee (AC.1) of the amended 1958 Agreement at its fourteenth session, following the recommendation by WP.29 at its one-hundred-and-twentieth session. It is based on document TRANS/WP.29/2000/29, as amended (TRANS/WP.29/703, para. 183).

Insert new paragraphs 4.7. and 4.8., to read:

"4.7. In the case of child restraints with alternative belt routes, the alternative load bearing contact points between the child restraint and the adult safety-belt must be permanently marked. This marking shall indicate that it is the alternative belt route, and shall conform with the above coding requirements for forward and rearward facing seats.

4.8. If the child restraint offers alternative load bearing contact points, the marking required in paragraph 4.3. shall include an indication that the alternative belt route is described in the instructions."

Paragraph 5.4.2.2.; amend to read:

"5.4.2.2. the mass range for which the child restraint has been designed, namely, 0-10 kg; 0-13 kg; 9-18 kg; 15-25 kg; 22-36 kg; 0-18 kg; 9-25 kg; 15-36 kg; 0-25 kg; 9-36 kg; 0-36 kg."

Paragraph 6.1.2., amend to read:

"....whenever the restraint is ready to use. This is to be determined as a line perpendicular to the seat back through the eye line, the point of intersection shall be at least 40 mm below the start of radius of such a head support."

Paragraph 6.1.4., amend to read:

"....by either an adult belt, using the test as specified in paragraph 8.1.4., or by separate means."

Paragraph 6.1.8., amend to read:

"....This shall apply to all adjustment configurations. Additional alternative belt routes are allowed. Where an alternative belt route exists, the manufacturer must make specific reference to the alternative route in the user instructions, as required in paragraph 14. When tested, using such alternative belt route(s), the restraint shall comply with all the requirements of the Regulation with the exception of this paragraph."

Paragraph 6.2.1.3., amend to read:

"6.2.1.3. If it is possible to change the inclination of the restraint, this change in inclination shall not require manual readjustment of the straps. A deliberate hand-action is required in order to change the inclination of the restraint."

Insert new paragraphs 7.1.5. to 7.1.5.2., to read:

"7.1.5. Resistance to temperature

7.1.5.1. Buckle assemblies, retractors, adjusters and lock-off devices that are liable to be affected by temperature, shall be subject to the temperature test specified in paragraph 8.2.8. below.

7.1.5.2. After the temperature test as prescribed in paragraph 8.2.8.1., no signs of deterioration likely to impair the proper functioning of the child restraint, shall be visible to the unaided eye of a qualified observer."

Paragraph 7.2.1.2., amend to read:

"... and a width of not less than 10 mm. The width shall be the smaller of the two dimensions forming the prescribed area and shall be measured rectangular to the direction of movement of the release button."

Paragraph 7.2.1.7., amend to read:

"7.2.1.7. The buckle shall be capable of withstanding the temperature test operation requirements given in paragraph 8.2.8.1. and repeated operation, and shall, before the dynamic test prescribed in paragraph 8.1.3. undergo"

Paragraph 7.2.2.5., amend to read:

"..... adjusting devices shall be tested as prescribed by the temperature test operation requirements given in paragraph 8.2.8.1. and in paragraph 8.2.3. below."

Paragraph 7.2.3.1.3., amend to read:

"..... The retractor shall then be subjected to the temperature test operation requirements given in paragraph 8.2.8.1. and corrosion test described in paragraph 8.1.1"

Paragraph 7.2.3.2.6., amend to read:

"..... The retractor shall then be subjected to the temperature test operation requirements given in paragraph 8.2.8.1. and corrosion test described in paragraph 8.1.1"

Paragraph 7.2.5.2., amend to read:

"..... the durability of the adult belt and undergo temperature test operation requirements given in paragraph 8.2.8.1."

Paragraph 8.1.3.6.3.1., amend to read:

"8.1.3.6.3.1. The manikin shall be placed so that the gap is between the rear of the manikin and the restraint. In the case of carry-cots"

Paragraph 8.1.3.6.3.2., amend to read:

"8.1.3.6.3.2. Place the child chair on the test seat.
Place the manikin in the child chair.
Place a hinged board or a similar flexible device 2.5 cm thick and 6 cm wide and of length equal to the shoulder height (sitting, annex 8) less the hip centre height (sitting, in annex 8 popliteus height plus half of thigh height, sitting) relevant to the manikin size being tested between the manikin and the seat backof the manikin's hip joint.
Adjust the belt by the manufacturer.
Complete the installation annex 21 to this Regulation.
Remove the flexible device.
This only applies to harness restraints and to restraints where the child is restrained by the adult three-point belt and where a lock-off device is used and does not apply to child restraining straps connected directly to a retractor."

Paragraph 8.1.3.6.3.4., amend to read:

"..... masking tape of sufficient length and width. In the case of rear-facing restraints, it is permitted to use a light-weight masking tape to connect the dummy's head to the 100 mm bar or the back of the restraint during the sled acceleration."

Paragraph 8.1.3.7.7., amend to read:

"..... and the heaviest manikins specified above shall be carried out. The tests shall be conducted using the test seat as shown in annex 6, appendix 3, figure 3. The laboratory conducting the tests may, if it deems"

Insert a new paragraph 8.1.4., to read:

"8.1.4. Restraint of booster cushions

Place a cotton cloth on the seating surface of the test bench. Position the booster cushion on the test bench, position the lower torso body block as described in annex 22, figure 1, on the seating surface, fit and apply the 3-point adult safety-belt and tension as prescribed in annex 21. With a piece of 25 mm width webbing or similar tied round the booster, apply a load of 250 ± 5 N in the direction of arrow A, see annex 22, figure 2, in line with the seating surface of the test bench."

Paragraph 8.2.1.1.2., amend to read.

"..... or the vehicle without opening the buckle. A load shall be applied to the buckle by direct traction via the strap tied to it so that all the straps are subjected to the force of $80/n$ daN; in this ratio "n" is the number of straps linked to the buckle when it is in a locked position, its minimum is deemed to be 2, if the buckle is connected to a rigid part. Account must be taken, when the force is applied, of the angle formed by the buckle and the rigid part during the dynamic test."

Insert new paragraphs 8.2.8. and 8.2.8.1., to read:

"8.2.8. Temperature test

8.2.8.1. The components specified in paragraph 7.1.5.1. shall be exposed to an environment over a water surface within a closed space, the environment having a temperature of not less than 80°C, for a continuous period of not less than 24 hours and then cooled in an environment having a temperature not exceeding 23°C. The cooling period shall immediately be followed by three consecutive 24 hour cycles with each cycle comprising the following consecutive sequences:

- (i) an environment having a temperature of not less than 100°C shall be maintained for a continuous period of 6 hours and this environment shall be attained within 80 minutes of commencement of the cycle; then
- (ii) an environment having a temperature of not more than 0°C shall be maintained for a continuous period of 6 hours and this environment shall be attained within 90 minutes; then
- (iii) an environment having a temperature of not more than 23°C shall be maintained during the remainder of the 24 hour cycle."

Insert new paragraphs 14.3.14. to 14.3.17., to read:

"14.3.14. There shall be a text or a diagram indicating how a user can identify an unsatisfactory position of the adult safety-belt buckle relative to the main load bearing contact points on the restraint. The user shall be advised to contact the child restraint manufacturer if in doubt about this point.

14.3.15. If the child restraint offers an alternative load bearing contact point, its use shall be described clearly. The user shall be informed about how to judge if use of this alternative route is satisfactory. The user shall be advised to contact the child restraint manufacturer if in doubt about this point. The user shall be clearly advised to begin the child restraint

installation, in vehicle seating positions categorized as "Universal" in the vehicle owner's manual, by using the primary belt route.

14.3.16. There shall be provisions made so that the instructions can be retained on the child restraint for its life period or in the vehicle handbook in the case of built-in restraints.

14.3.17. There shall be explicit warning not to use any load bearing contact points other than those described in the instructions and marked in the child restraint."

Annex 13,

Paragraph 3., amend to read:

"....
the value of X in Figure 1 below is 200 ± 5 mm. the value of P-A1 for "universal" and "semi-universal" restraints is 2220 ± 5 mm
..... The value of P-A1 for "restricted" child restraints is at least 2220 ± 5 mm, measured parallel to the centreline"

Annex 15,

Insert a new note to paragraph 6.1.8., to read:

"Paragraph 6.1.8.

The 150 mm requirement also applies to carry cots, except if a special device is used to link the carry cot and the safety-belt."

Note to paragraph 6.2.4., amend to read:

"Paragraph 6.2.4.

The limit of acceptable movement of the shoulder belt is that the lower edge of the shoulder portion of the standard safety-belt shall not be lower than the dummy's elbow at the point of maximum excursion of the dummy."

Insert a new note to paragraph 6.2.9., to read:

"Paragraph 6.2.9.

Common understanding is that it applies also to devices that have such a lock-off even if they are not required for that group. Thus the test would be applied to a group 2 only device, but at the prescribed force, i.e. twice the mass of group 1 dummy."

Annex 16,

Insert a new paragraph 1.7., to read:

"1.7. Temperature test

According to the provisions of paragraph 7.1.5. of this Regulation."

Annex 18,

Paragraph 1., amend to read:

"..... of the child seat. In the case of carry cot devices the lower limit of area at which material complying with annex 17 shall be used shall be all areas forward of the smaller dummy's rearward shoulder when measured with this dummy in the carry cot and the carry cot positioned on the test bench."

Annex 21,

Insert a new paragraph 1.2.4., to read:

"1.2.4. Before commencing the set-up, check the child restraint to determine compliance with paragraph 6.2.1.3. If there is a change in installation tension due to the change of angle function, then test for the condition which creates the slackest installation, conduct the set-up and tension in the tightest position and then reposition the child restraint to the worst case without re-tensioning the adult belt. Conduct the dynamic test."

Insert a new note 4., to read:

"4. In the case of restraints fitted with devices intended to increase the adult safety-belt tension, the test method shall be: Install the child restraint system as required in this annex and then apply the tensioner device as stated in the manufacturers instructions. If the device cannot be applied due to excess tension then it is deemed to be an unacceptable device."

Insert a new annex 22, to read:

"Annex 22

LOWER TORSO BODY BLOCK TEST

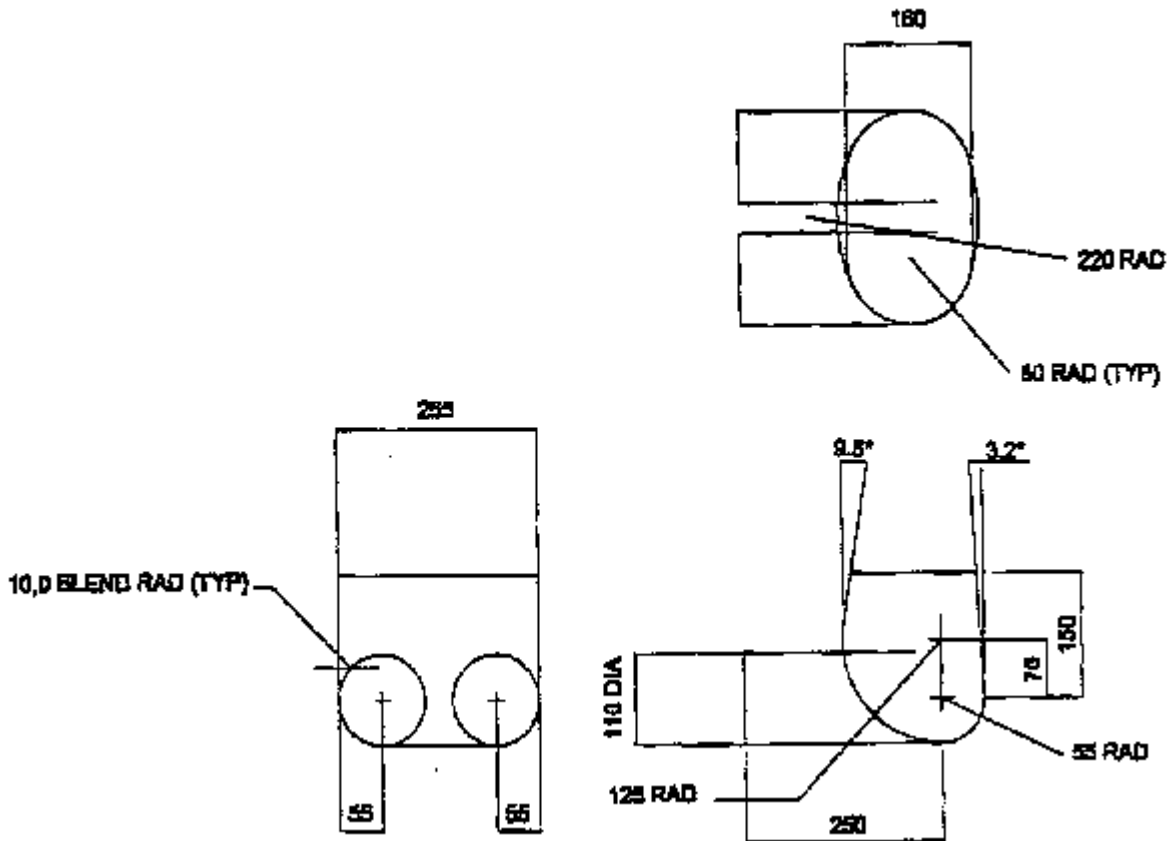

Figure 1 : Truncated P10 manikin block
Material: EPS (40 to 45 g/l)

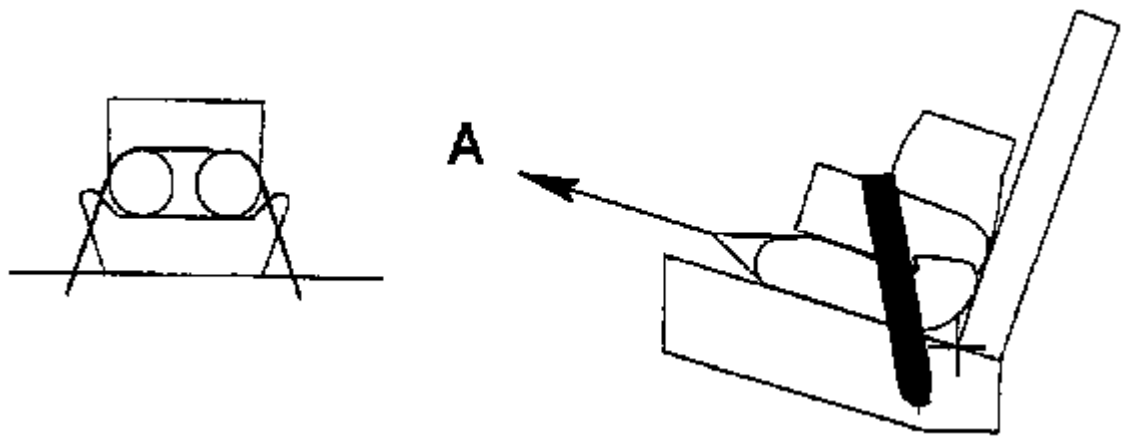

Figure 2 : Booster pull test using manikin block

_____”