



**Economic and Social  
Council**

Distr.

GENERAL

TRANS/WP.29/671

8 April 1999

ENGLISH

Original: ENGLISH and  
FRENCH

---

ECONOMIC COMMISSION FOR EUROPE

INLAND TRANSPORT COMMITTEE

Working Party on the Construction of Vehicles

DRAFT SUPPLEMENT 4 TO REGULATION No. 43

(Safety glazing)

Note: The text reproduced below was adopted by the Administrative Committee (AC.1) of the amended 1958 Agreement at its eleventh session, following the recommendation by the Working Party at its one-hundred-and-seventeenth session. It is based on document TRANS/WP.29/1999/13, as amended (TRANS/WP.29/663, para. 120 and annex 3).

GE.99-

The title of the Regulation, amend to read:

"UNIFORM PROVISIONS CONCERNING THE APPROVAL OF SAFETY GLAZING MATERIALS"

The List of Contents,

Regulation, item 9., amend to read:

"9. Modification or extension of approval of a type of safety glazing material"

Annexes, amend to read:

"....

- Annex 13 - Grouping of windscreens for approval testing
- Annex 14 - Rigid plastic glazings other than windscreens
- Annex 15 - Flexible plastic glazings other than windscreens
- Annex 16 - Rigid plastic double-glazed unit
- Annex 17 - Measurement of the heights of segment and position of the points of impact
- Annex 18 - Procedures for determining test areas on windscreens of M<sub>1</sub> category vehicles in relation to the "V" points
- Annex 19 - Procedure for determining the "H" point and the actual torso angle for seating positions in motor vehicles.
- Annex 20 - Checks on conformity of production"

The text of the Regulation,

Paragraph 1.1., amend to read:

"1.1. This Regulation applies to safety glazing materials intended for installation as windscreens or other panes, or as partitioning, on power-driven vehicles and their trailers, to the exclusion, however, of glazings for lighting and light-signalling devices and instrument panels, and of special bullet-proof glazings.

This Regulation does not concern the installation of safety glazing materials on power-driven vehicles and their trailers or double windows."

Insert new paragraphs 2.5. to 2.5.2., to read:

"2.5. "Plastic glazing" is a glazing material that contains as an essential ingredient one or more organic polymeric substances of large molecular weight, is solid in its finished state and, at some stage in its manufacture or processing into finished articles, can be shaped by flow;

2.5.1 "Rigid plastic glazing" means a plastic glazing material which does not deflect vertically more than 50 mm in the flexibility test (annex 3, paragraph 12.);

2.5.2. "Flexible plastic glazing" means a plastic glazing material which deflects vertically more than 50 mm in the flexibility test (annex 3, paragraph 12.)."

(Note: (French version only), delete the words "ne ..... pas".)

Paragraphs 2.5. to 2.5.2. (former), renumber as paragraphs 2.13. to 2.13.2. and amend to read:

- "2.13. "Group of windscreens" means a group comprising windscreens of differing sizes and shapes subjected to an examination of their mechanical properties, their mode of fragmentation and their behaviour in environmental-aggression resistance tests;
- 2.13.1. "Flat windscreen" means a windscreen exhibiting no normal curvature resulting in a height of segment greater than 10 mm per linear metre;
- "2.13.2. "Curved windscreen" means a windscreen exhibiting a normal curvature resulting in a height of segment greater than 10 mm per linear metre."

Paragraphs 2.6. and 2.7., amend the words "glass panes" to read "glazing panes" (twice).

Paragraphs 2.7.1. to 2.9., amend to read:

- "2.7.1. "Symmetrical double-glazing" means a double-glazed unit where the two component glazings are of the same type (toughened glass, laminated glass, rigid plastic) and have the same principal and/or secondary characteristics;
- 2.7.2. "Asymmetrical double-glazing" means a double-glazed unit where the two component glazings are of different type (toughened glass, laminated glass, rigid plastic) or have different principal and/or secondary characteristics;
- 2.8. "Principal characteristic" means a characteristic which appreciably modifies the optical and/or mechanical properties of a safety glazing material in a way not without significance to the function which it is intended to perform in a vehicle. The term also covers the trade names or marks as specified by the holder of the approval;
- 2.9. "Secondary characteristic" means a characteristic capable of modifying the optical and/or mechanical properties of a safety glazing material in a way which is of significance to the function which it is intended to perform in a vehicle. The extent of such modification is assessed in relation to the indices of difficulty."

Paragraph 2.13., renumber as paragraph 2.14. and amend the reference to "annex 14, figure 1" to read "annex 17, figure 1".

Paragraphs 2.14. to 2.14.2., renumber as paragraphs 2.15. to 2.15.2. and amend to read:

- "2.15. "Type of safety glazing material" means a glazing as defined in paragraphs 2.1. to 2.7. not exhibiting any essential differences, with respect, in particular, to the principal and secondary characteristics defined in annexes 4 to 12 and 14 to 16;
- 2.15.1. Although a change in the principal characteristics implies that the product is of a new type, it is recognised that in certain cases a change in shape and dimension does not necessarily require a complete set of tests to be carried out. For certain of the

tests prescribed in the individual annexes, glazings may be grouped if it is evident that they have similar principal characteristics;

- 2.15.2. Types of glazing exhibiting differences only as regards their secondary characteristics may be deemed to be of the same type; certain tests may however be carried out on samples of such glazings if the performance of those tests is explicitly stipulated in the test condition."

Paragraph 2.15. (former), renumber as paragraph 2.16.

Insert new paragraphs 2.17. and 2.18., to read:

- "2.17. "HIC" (Head Injury Criteria) value means a value for the characteristics of skull-brain injury arising from the deceleration forces which result from a blunt perpendicular impact with the glazing.
- 2.18. "Safety glazing material requisite for driver visibility" means safety glazing material used as a windscreen or a front side or door window mounted in the 180° angle forward to the driver."

Paragraphs 3.1. to 3.2.1.1., amend to read:

- "3.1. The application for approval of a type of glazing shall be submitted by the manufacturer or by his duly accredited representative in the country where the application is made.
- 3.2. For each type of glazing the application shall be accompanied by the undermentioned documents in triplicate and by the following particulars:
- 3.2.1. A technical description comprising all principal and secondary characteristics, and

3.2.1.1. In the case of glazings other than windscreens, diagrams in a format not exceeding A4 or folded to that format showing:

the maximum area,  
the smallest angle between two adjacent sides of the piece,  
the greatest height of segment, where applicable."

Paragraph 3.2.1.2.2.7., amend to read:

3.2.1.2.2.7. The minimum radius curvature of the windscreen (for windscreen-grouping purposes only)."

Paragraphs 3.2.1.3. and 3.3., amend to read:

"3.2.1.3. In the case of double-glazed units, diagrams in a format not exceeding A4 or folded to that format, showing, in addition to the information referred to in paragraph 3.2.1.1.:

the type of each component pane,  
the type of sealing,  
the nominal width of the gap between the two panes.

3.3. In addition, the applicant for approval shall submit a sufficient number of test pieces and samples of the finished pieces of the models considered, the number being if necessary determined by agreement with the technical service responsible for conducting the tests."

Paragraph 3.4., should be deleted.

Paragraphs 4. to 5.3., amend to read:

"4. MARKINGS

4.1. Every piece of safety glazing material, including the samples and test pieces submitted for approval, shall bear a trade name or mark as listed under item 3 of annex 1. Manufactured parts must bear the ECE Regulation No. 43 number allocated to the prime manufacturer. The marking shall be clearly legible and indelible.

5. APPROVAL

5.1. If the samples submitted for approval meet the requirements of paragraphs 6. to 8. of this Regulation, approval of the pertinent type of safety glazing material shall be granted.

5.2. An approval number shall be assigned to each type as defined in annexes 5, 7, 11, 12, 14, 15 and 16 or, in the case of windscreens, to each group approved. Its first two digits (at present 00 for the Regulation in its original form) shall indicate the series of amendments incorporating the most recent major technical amendments made to the Regulation at the time of issue of the approval. The same Contracting Party may not assign the

same number to another type or group of safety glazing material.

- 5.3. Notice of approval or extension of approval or refusal of approval of a type of safety glazing material pursuant to this Regulation shall be communicated to the Parties to the Agreement applying this Regulation, by means of a form conforming to the model in annex 1 - and its appendices - to this Regulation."

Paragraph 5.4., amend the words "safety-glass pane" to read "piece of glazing".

Paragraph 5.4.1., footnote 1/ pertinent to this paragraph, amend to read:

"1/ 1 for Germany, 2 for France, 3 for Italy, 4 for the Netherlands, 5 for Sweden, 6 for Belgium, 7 for Hungary, 8 for the Czech Republic, 9 for Spain, 10 for Yugoslavia, 11 for the United Kingdom, 12 for Austria, 13 for Luxembourg, 14 for Switzerland, 15 (vacant), 16 for Norway, 17 for Finland, 18 for Denmark, 19 for Romania, 20 for Poland, 21 for Portugal, 22 for the Russian Federation, 23 for Greece, 24 for Ireland, 25 for Croatia, 26 for Slovenia, 27 for Slovakia, 28 for Belarus, 29 for Estonia, 30 (vacant), 31 for Bosnia and Herzegovina, 32 for Latvia, 33-36 (vacant), 37 for Turkey, 38-39 (vacant), 40 for the former Yugoslav Republic of Macedonia, 41 (vacant), 42 for the European Community (Approvals are granted by its Member States using their respective ECE symbol) and 43 for Japan. Subsequent numbers shall be assigned to other countries in the chronological order in which they ratify the Agreement Concerning the Adoption of Uniform Technical Prescriptions for Wheeled Vehicles, Equipment and Parts which can be Fitted and/or be Used on Wheeled Vehicles and the Conditions for Reciprocal Recognition of Approvals Granted on the Basis of these Prescriptions, or in which they accede to that Agreement, and the numbers thus assigned shall be communicated by the Secretary-General of the United Nations to the Contracting Parties to the Agreement."

Paragraph 5.5.2., amend the words "glass-pane" to read "glazing".

Paragraph 5.5.4., amend the value of "30 km/h" to read "40 km/h".

Insert new paragraphs 5.5.5. to 5.5.7., to read:

- "5.5.5. VIII. In the case of rigid plastic glazing. In addition the appropriate application will be signified by:
- /A for forward facing panels
  - /B for side, rear and roof glazing
  - /C in locations where there is little or no chance of head impact
- 5.5.6. IX. in the case of flexible-plastic glazing
- 5.5.7. X. in the case of a rigid plastic double-glazed unit"

Paragraph 6.1., amend the word "glass" to read "glazing material" (twice).

Paragraph 6.2., amend the word "glass" to read "glazing materials" (twice).

Paragraph 7., amend the word "glass" to read "glazing".

Insert new paragraphs 7.10., to 7.12., to read:

- "7.10. As regards rigid plastic glazings, the requirements contained in annex 14.
- 7.11. As regards flexible plastic glazings, the requirements contained in annex 15.
- 7.12. As regards rigid plastic double-glazed units, the requirements contained in annex 16."

Paragraph 8.1.2.1.1., amend to read:

"... strength of uniformly-toughened glass and plastic glazings."

Paragraph 8.1.2.2., amend to read:

"8.1.2.2. Headform test

The purpose of this test is to verify the compliance of glazing with the requirements relating to the limitation of injury in the event of impact of the head against the windscreen, laminated glass and panes of glass-plastic and rigid plastic other than windscreens, together with the double-glazed units used in the side windows."

Paragraph 8.1.3.1. amend the words "safety-glass pane" to read "safety glazing".

Paragraph 8.1.3.4., amend to read:

"8.1.3.4. Resistance-to-humidity test

The purpose of this test is to determine whether laminated-glass panes, glass-plastic panes, glass panes faced with plastic material and rigid plastic material will withstand, without significant deterioration, the effects of prolonged exposure to atmospheric humidity."

Insert new paragraphs 8.1.3.6. and 8.1.3.7., to read:

"8.1.3.6. Resistance to simulated weathering test

The purpose of this test is to verify that plastic safety glazing is resistant to simulated weathering conditions.

8.1.3.7. Cross cut test

The purpose of this test is to examine whether any abrasive resistant coating of a rigid plastic glazing has sufficient adherence."

Paragraph 8.1.4.1., amend the words "safety-glass panes" to read "safety glazing".

Paragraphs 8.1.5. and 8.1.6., amend to read:

"8.1.5. Burning-behaviour (fire-resistance) test

The purpose of this test is to verify that a safety glazing material as defined in paragraphs 2.3., 2.4. and 2.5. above has a sufficiently low burn rate.

8.1.6. Test of resistance to chemicals

The purpose of this test is to determine whether the safety glazing material as defined in paragraphs 2.3., 2.4. and 2.5. above will withstand the effects of exposure to chemicals likely to be normally present or used within the vehicle (e.g. cleaning compounds) without significant deterioration."

Insert a new paragraph 8.1.7., to read:

"8.1.7. Flexibility and fold test

The purpose of this test is to determine whether a plastic glazing material falls within the rigid or flexible category."



Paragraphs 8.2. to 8.2.2. (including the table), amend to read:

"8.2. Tests prescribed for glazing materials of the categories defined in paragraphs 2.1. to 2.5. of this Regulation

8.2.1. Safety glazing materials shall be subjected to the tests listed in the following tables: 8.2.1.1. and 8.2.1.2.

8.2.1.1. Safety glass panes shall be subjected to the tests listed in the following table.

Tests	Windscreen							Glass panes other than windscreens		
	Toughened glass		Ordinary laminated glass		Treated laminated glass		Glass-plastics	Toughened glass	Laminated glass	Glass-plastics
	I	I-P	II	II-P	III	III-P	IV			
Fragmentation:	A4/2	A4/2	-	-	A8/4	A8/4	-	A5/2	-	-
Mechanical strength										
- 227 g ball	-	-	A6/4.3	A6/4.3	A6/4.3	A6/4.3	A6/4.3	A5/3.1	A7/4	A7/4
- 2 260 g ball	-	-	A6/4.2	A6/4.2	A6/4.2	A6/4.2	A6/4.2	-	-	-
Head form test <u>1/</u>	A4/3	A4/3	A6/3	A6/3	A6/3	A6/3	A10/3	-	A7/3	A11/3
Abrasion										
Outer face	-	-	A6/5.1	A6/5.1	A6/5.1	A6/5.1	A6/5.1	-	A6/5.1	A6/5.1
Inner face	-	A9/2	-	A9/2	-	A9/2	A9/2	A9/2 <u>2/</u>	A9/2 <u>2/</u>	A9/2
High temperature	-	-	A3/5	A3/5	A3/5	A3/5	A3/5	-	A3/5	A3/5
Radiation	-	A3/6	A3/6	A3/6	A3/6	A3/6	A3/6	-	A3/6	A3/6
Humidity	-	A3/7	A3/7	A3/7	A3/7	A3/7	A3/7	A3/7 <u>2/</u>	A3/7	A3/7
Light transmission	A3/9.1	A3/9.1	A3/9.1	A3/9.1	A3/9.1	A3/9.1	A3/9.1	A3/9.1	A3/9.1	A3/9.1
Optional distortion	A3/9.2	A3/9.2	A3/9.2	A3/9.2	A3/9.2	A3/9.2	A3/9.2	A3/9.2 <u>3/</u>	-	-
Secondary image	A3/9.3	A3/9.3	A3/9.3	A3/9.3	A3/9.3	A3/9.3	A3/9.3	A3/9.3 <u>3/</u>	-	-
Identification of colours	A3/9.4	A3/9.4	A3/9.4	A3/9.4	A3/9.4	A3/9.4	A3/9.4	-	-	-
Resistance to temperature changes	-	A3/8	-	A3/8	-	A3/8	A3/8	A3/8 <u>2/</u>	A3/8 <u>2/</u>	A3/8
Fire resistance	-	A3/10	-	A3/10	-	A3/10	A3/10	A3/10 <u>2/</u>		A3/10
Resistance to chemicals	-	A3/11	-	A3/11	-	A3/11	A3/11	A3/11 <u>2/</u>	A3/11 <u>2/</u>	A3/11

1/ Furthermore this test shall be carried out on double-glazed units pursuant to annex 12 paragraph (A12/3).

2/ If coated on the inner side with plastics material.

3/ This test shall only be carried out on uniformly-toughened glass-panes to be used as windscreens slow-moving vehicles which, by construction, cannot exceed 40 km/h.

Note: A reference such as A4/3 in the table indicates the annex (4) and paragraph (3) of that annex, where the relevant test is described and the acceptance requirements are specified.

8.2.1.2. Plastic glazing materials shall be subjected to the tests listed in the following table.

Test	Plastics Other Than Windscreens				
	Rigid Plastics		Double Glazing		Flexible Plastics
	Motorised Vehicles	Trailers and Unoccupied Vehicles	Motorised Vehicles	Trailers and Unoccupied Vehicles	
Flexibility	A3/12	A3/12	A3/12	A3/12	A3/12
227 g ball	A14/5	A14/5	A16/5	A16/5	A15/4
Headform <u>1</u> /	A14/4	-	A16/4	-	-
Light transmission	A3/9.1	-	A3/9.1	-	A3/9.1
Fire Resistance	A3/10	A3/10	A3/10	A3/10	A3/10
Chemical Resistance	A3/11	A3/11	A3/11	A3/11	A3/11
Abrasion	A14/6.1	-	A16/6.1	-	-
Weathering	A3/6.4	A3/6.4	A3/6.4	A3/6.4	A3/6.4
Humidity	A14/6.4	A14/6.4	A16/6.4	A16/6.4	-
Cross-Cut <u>2</u> /	A3/13	-	A3/13	-	-

1/ Test requirements are dependant on the location of the glazing within the vehicle.

2/ Applies only if the glazing is to be used in a location requisite for driving visibility.

8.2.2. A safety glazing material shall be approved if it meets all the requirements prescribed in the relevant provisions referred to in the tables: 8.2.1.1 and 8.2.1.2."

Paragraphs 9., 9.1. and 9.1.1., amend the words "safety-glass pane" to read "safety glazing material" (four times).

Paragraphs 10. to 10.3., amend to read:

"10. CONFORMITY OF PRODUCTION

10.1. The conformity of production procedures shall comply with those set out in the Agreement, appendix 2 (E/ECE/324-E/ECE/TRANS/505/Rev.2), with the following requirements:

10.2. Special provisions  
The checks referred to in paragraph 2.2. of Appendix 2 of the Agreement shall include compliance with the requirements of annex 20 to this Regulation.

10.3. The normal frequency of inspection as referred to in paragraph 2.4. of appendix 2 of the Agreement shall be one per year."

Paragraphs 10.3.1. to 10.4.5., should be deleted.

Paragraph 11.1., amend the words "safety-glass pane" to read "safety glazing material".

Paragraph 13., amend the words "safety-glass pane" to read "safety glazing material".

Insert a new paragraph 15., to read:

"15. The technical services responsible for conducting approval tests shall comply with the harmonized standards concerning the operation of testing laboratories (ISO/CEI Guide 25). In addition they should be designated by the approval authority for which they carry out the approval tests.

Annex 1, amend to read:

"Annex 1

(maximum format: A4 (210 x 297 mm))

**COMMUNICATION**

issued by: Name of administration:  
.....  
.....  
.....



Concerning: 2/ APPROVAL GRANTED  
APPROVAL EXTENDED  
APPROVAL REFUSED  
APPROVAL WITHDRAWN  
PRODUCTION DEFINITELY DISCONTINUED

of a type of safety glazing material pursuant to Regulation No. 43.

Approval No . . . . . Extension No. . . . .

- 1. Class of safety glazing material: . . . . .
- 2. Description of the type of glazing: please refer to appendix 1, 2, 3, 4, 5, 6, 7, 8, and 9 2/, and in the case of windscreens, the list conforming to appendix 10.
- 3. Trade names or marks . . . . .
- 4. Manufacturer's name and address . . . . .
- 5. If applicable, name and address of manufacturer's representative .

6. Submitted for approval on: . . . . .
7. Technical service responsible for conducting approval tests: . . .
8. Date of report issued by that service: . . . . .
9. Number of report issued by that service: . . . . .
10. Approval is granted/refused/extended/withdrawn 2/ . . . . .
11. Reason(s) for extension of approval: . . . . .
12. Remarks: . . . . .
13. Place . . . . .
14. Date . . . . .
15. Signature . . . . .
16. The list of documents filed with the administrative service which has granted approval and available on request is annexed to this communication.

---

1/ Distinguishing number of the country which has granted/extended/refused/withdrawn approval (see approval provisions in the Regulation).

2/ Strike out what does not apply.

\_\_\_\_\_ "

Annex 1 – Appendix 1, amend the words:

"Thickness of plastic coating(s) ..." to read "Nominal thickness of plastic coating(s) ...", "Anti-glare strips incorporated (Yes/No) ..." to read "Obscuration bands incorporated (Yes/No) ...", and the reference to "appendix 8" in the footnote to read "appendix 10".

Annex 1 – Appendix 2, after the words "Nature and type of plastic coating(s) ...", insert a new line, reading: "Nominal thickness of plastic coating(s) ...". In addition, amend the words "Anti-glare strips incorporated (Yes/No) ..." to read "Obscuration bands incorporated (Yes/No) ..." and the reference to "appendix 8" in the footnote to read "appendix 10".

Annex 1 - Appendix 3, after the words "Nature and type of plastic coating(s) ...", insert a new line, reading: "Nominal thickness of plastic coating(s) ...". Insert a line, reading: "Colouring of interlayer (total/partial)". In addition, amend the words "Anti-glare strips incorporated (Yes/No) ..." to read "Obscuration bands incorporated (Yes/No) ..." and the reference to "appendix 8" in the footnote to read "appendix 10".

Annex 1 - Appendix 4, amend the words:

"Thickness of plastic coating(s) ..." to read "Nominal thickness of plastic coating(s) ..." and "Anti-glare strips incorporated (Yes/No) ..." to read "Obscuration bands incorporated (Yes/No) ...".

Annex 1 - Appendix 5, amend the words:

"Anti-glare strips incorporated (Yes/No) ..." to read "Obscuration bands incorporated (Yes/No)..." and the reference to "appendix 8" in the footnote to read "appendix 10".

Annex 1 - Appendix 6, amend the words:

"Anti-glare strips incorporated (Yes/No) ..." to read "Obscuration bands incorporated (Yes/No) ...".

Annex 1 - Appendix 7, amend to read:

"Annex 1 - Appendix 7

DOUBLE GLAZED UNITS

(Principal and secondary characteristics as defined in annex 12 or annex 16 to Regulation No. 43)

Approval No.: . . . . . Extension No.: . . . . .

Principal characteristics:

- Composition of double-glazed units (symmetrical/asymmetrical) . . . . . :
- Nominal thickness of the gap: . . . . . :
- Method of assembly: . . . . . :
- Type of each glazing component as defined in annexes 5, 7, 9, 11 or 14 . . . :

Documents attached:

One form for the two panes of a symmetrical double-glazed unit in accordance with the annex under which the panes have been tested or approved.

One form for each pane of an asymmetrical double-glazed unit in accordance with the annexes under which these panes have been tested or approved.

Remarks"

Insert new Annex 1 - Appendices 8 and 9, to read:

"Annex 1 - Appendix 8

RIGID PLASTICS PANES OTHER THAN WINDSCREENS

(Principal and secondary characteristics in  
accordance with annex 14)

Approval No.: . . . . . Extension No.: . . . . .

Principal characteristics:

- Chemical designation of the material :
- The classification of the material by the manufacturer.....:
- Process of manufacture.....:
- Shape and dimensions.....:
- Nominal thickness.....:
- Colouring of the rigid plastic material.....:
- Nature and type of surface coating.....:

Secondary characteristics

Conductors incorporated (YES/NO).....:

Remarks

Annex 1 - Appendix 9

PANES OF FLEXIBLE PLASTICS OTHER THAN WINDSCREENS

(Principal and secondary characteristics in  
accordance with annex 15)

Approval No.: . . . . . Extension No.: . . . . .

Principal characteristics:

- Chemical designation of the material.....:
- Process of manufacture.....:
- Nominal thickness.....:
- Colouring of the plastic product.....:
- Nature and type of surface coating.....:

Secondary characteristics

No secondary characteristic is involved.

Remarks "

Annex 1 – Appendix 8 (former), renumber as "Annex 1 - Appendix 10".

Annex 2,

The captions below the existing examples of approval marks, delete the words "in its original form or as amended by Supplements 1, 2 and/or 3, as the case may be" (4 times), ".... Supplements 2 and/or 3 ...." (4 times) and ".... Supplements 1, 2 and 3 ...." (2 times).

The example titled "Uniformly-toughened glass panes to be used ... 30 km/h", amend the value of "30 km/h" to read "40 km/h".

In addition, add at the end of this annex three new examples of approval marks, to read:

"Rigid plastic glazings other than windscreens

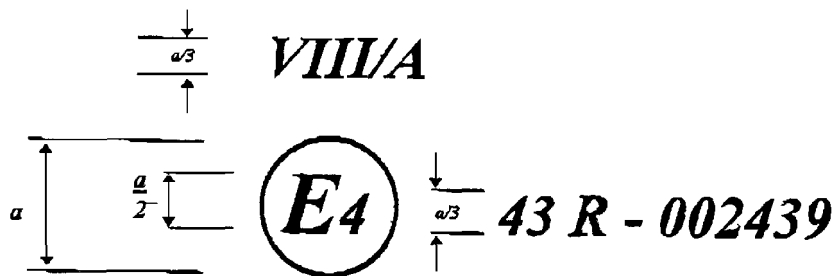

*a = 8 mm min.*

The above approval mark affixed to a rigid plastic glazing pane for forward facing panels shows that the component concerned has been approved in the Netherlands (E 4) pursuant to Regulation No. 43 under approval No. 002439. The approval number indicates that the approval was granted in accordance with the requirements of Regulation No. 43.

Flexible plastic glazings other than windscreens

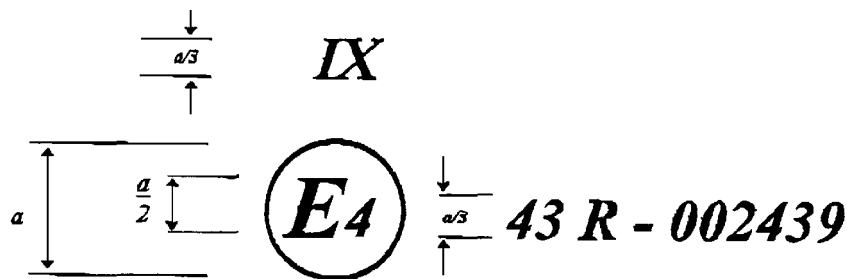

*a = 8 mm min.*

The above approval mark affixed to a flexible plastic glazing pane shows that the component concerned has been approved in the Netherlands (E 4) pursuant to Regulation No. 43 under approval No. 002439. The approval number indicates that the approval was granted in accordance with the requirements of Regulation No. 43.

Rigid plastic double glazed units

FIGURE OFFSET

The above approval mark affixed to rigid plastic double glazed units shows that the component concerned has been approved in the Netherlands (E 4) pursuant to Regulation No. 43 under approval No. 002439. The approval number indicates that the approval was granted in accordance with the requirements of Regulation No. 43.

Annex 3,

Paragraphs 2.1.3. and 2.1.4., amend to read:

"2.1.3. Test piece

The test piece shall be a flat square of side 300 +10/-0 mm or shall be cut from the flattest part of a windscreen or other curved pane of safety glazing.

Alternatively a curved pane of safety glazing may be tested. In this case care shall be taken to ensure adequate contact between the safety glazing and the support.

2.1.4. Procedure



Condition the test piece at the specified temperature for at least four hours immediately preceding the test.

Place the test piece in the fixture (paragraph 2.1.1.3.). The plane of the test piece shall be perpendicular, within 3°, to the incident direction of the ball.

In the case of flexible plastic glazing the test piece shall be clamped to the support.

The point of impact shall be within 25 mm of the geometric centre of the test piece for a drop height less than or equal to 6 m, and within 50 mm of the centre of the test piece for a drop height greater than 6 m. The ball shall strike that face of the test piece which represents the outside face of the safety-glazing pane when mounted on the vehicle. The ball shall be allowed to make only one impact."

Paragraph 2.2.3., amend to read:

"2.2.3. Test piece

The test piece shall be a flat square of side 300 +10/-0 mm or shall be cut out from the flattest part of a windscreen or other curved pane of safety glazing.

Alternatively, the whole windscreen or other curved pane of safety glazing may be tested. In this case care shall be taken to ensure adequate contact between the safety glazing pane and the support."

Paragraphs 3.1. and 3.1.1., amend to read:

"3.1. Headform test without deceleration measurement

3.1.1. Apparatus

Headform weight with a spherical or semi-spherical headform made of ...".

Paragraph 3.2., renumber as paragraph 3.1.4.

Paragraph 3.3., renumber as paragraph 3.1.5.

Paragraph 3.3.1., renumber as paragraph 3.1.5.1. and amend to read:

"3.1.5.1. Test on a flat test piece

The flat test piece, having a length of  $1\ 100 \pm 5/-2$  mm and a width of  $500 \pm 5/-2$  mm, shall be kept at a constant temperature of  $20 \pm 5^\circ\text{C}$  for at least four hours immediately preceding the test.

Fix the test piece in the supporting frames (paragraph 3.1.3.); the torque on the bolts shall ....".

Paragraph 3.3.2., renumber as paragraph 3.1.5.2.

Insert new paragraphs 3.2., to 3.2.6., to read:

"3.2. Headform Test With Deceleration Measurement

3.2.1. Apparatus

In the case of headform tests with simultaneous determination of HIC-values the drop body is the phantom head as in figure 2.1. The total mass of the phantom head should be  $10.0 \pm 0.2/-0.0$  kg.

In the middle of the base plate (24) the triaxial mounting block (26) is mounted in the centre of gravity to receive the acceleration gauges (27). The acceleration gauges should be arranged vertically to each other.

The basin (18) and cover (19) situated under the base plate (24) share, to a great extent, the elastic properties of the human skull. The elastic properties of the phantom head on impact are determined by the hardness and the thickness of the intermediate ring (13) and the basin.

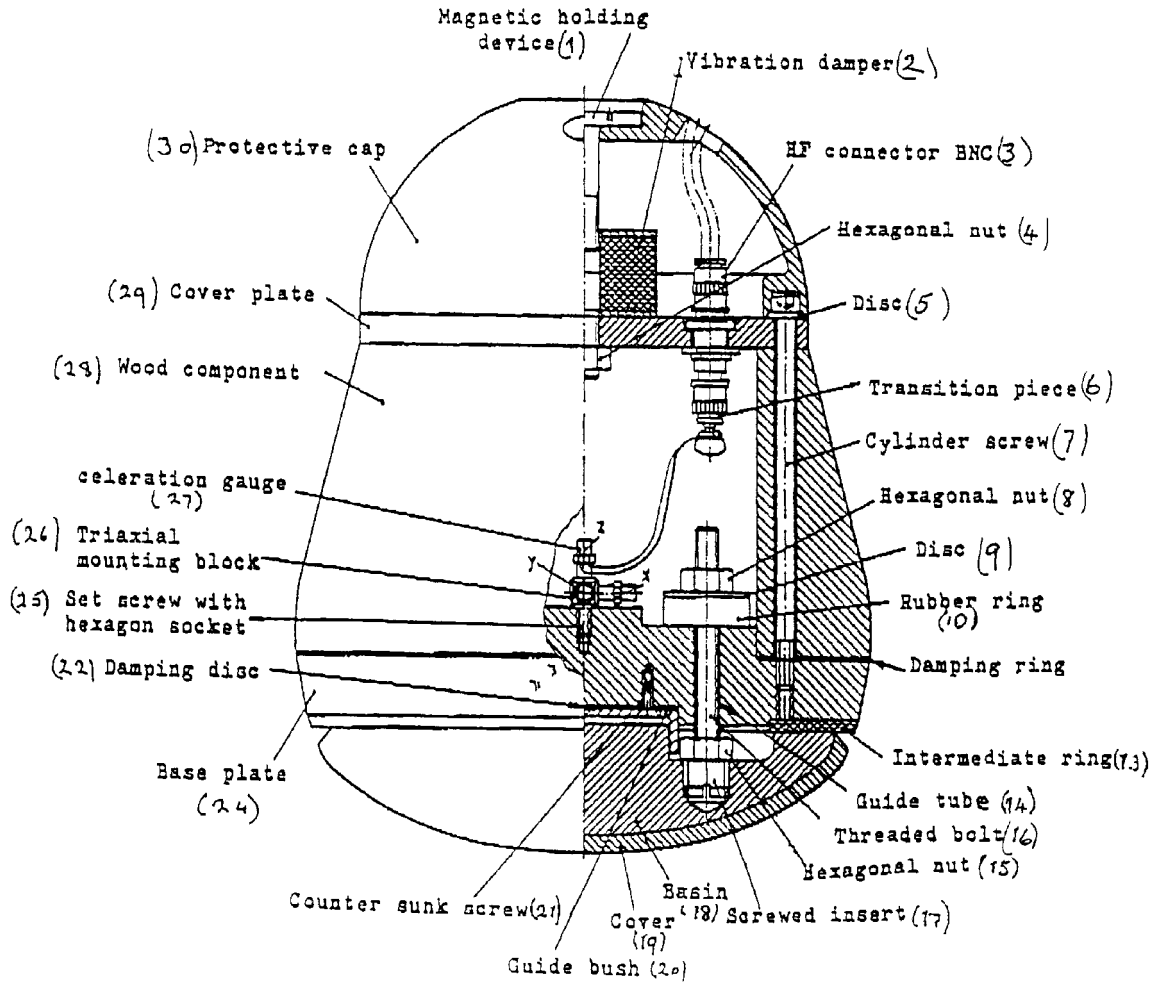

Figure 2.1

10 kg Headform

List of pieces for the 10 kg headform concerning figure 1

Position No.	Number of Pieces	Standard notation	Material	Remarks
1	1	Magnetic holding device	Steel DIN 17100	-
2	1	Vibration damper	Rubber / Steel	Diameter: 50 mm Thickness: 30 mm Thread: M10
3	4	HF connector BNC	-	-
4	1	Hexagonal nut DIN 985	-	-
5	6	Disc DIN 125	-	-
6	3	Transition piece	-	-
7	6	Cylinder screw DIN 912	-	-
8	3	Hexagonal nut	-	-
9	3	Disc	Steel DIN 17100	Hole Diameter: 8 mm Outer Diameter: 35 mm Thickness: 1.5mm
10	3	Rubber ring	Rubber, hardness 60 IRHD	Hole Diameter: 8 mm Outer Diameter: 30 mm Thickness: 10 mm
11	1	Damping ring	Packing with paper	Hole Diameter: 120mm Outer Diameter: 199mm Thickness: 0.5mm
12	-	-	-	-
13	1	Intermediate ring	Butadien-rubber, hardness IRHD about 80	Hole Diameter: 129mm Outer Diameter: 192mm Thick: about 4mm
14	3	Guide tube	Polytetrafluorethen (PTFE)	Inner Diameter: 8 mm Outer Diameter: 10 mm Length: 40 mm
15	3	Hexagonal nut	-	-
16	3	Threaded bolt DIN 976	-	-
17	3	Screwed insert	Cast alloy DIN 1709-GD- CuZn 37Pb	-
18	1	Basin	Polyamid 12	-
19	1	Cover	Butadien-rubber	Thickness: 6 mm Rib on one side
20	1	Guide bush	Steel DIN 17100	-
21	4	Counter sunk screw	-	-
22	1	Damping disc	Packing with paper	Diameter: 65 mm Thickness: 0.5 mm
23	-	-	-	-
24	1	Base plate	Steel DIN 17100	-
25	1	Set screw with hexagonal socket	Class of strength 45H	-
26	1	Triaxial mounting block	-	-
27	3	Acceleration gauge	-	-
28	1	Wood component	Hornbeam, glued in layers	-
29	1	Cover plate	Alloy (AlMg5)	-
30	1	Protective cap	Polyamid 12	-

### 3.2.2. Adjustment and Calibration

To perform the headform test the phantom head is fixed to the cross arm of the guide system (figure 2.2) and moved to the required drop height by means of a lifting device. During the headform test the cross arm with the phantom head is released. After passing the height adjustable light barrier the phantom head is released from the cross arm, the cross arm's fall is dampened and the phantom head falls onto the sample.

No impulse may be given to the phantom head by the drop appliance or by the measuring cable, so that it is accelerated only by gravity and falls vertically.

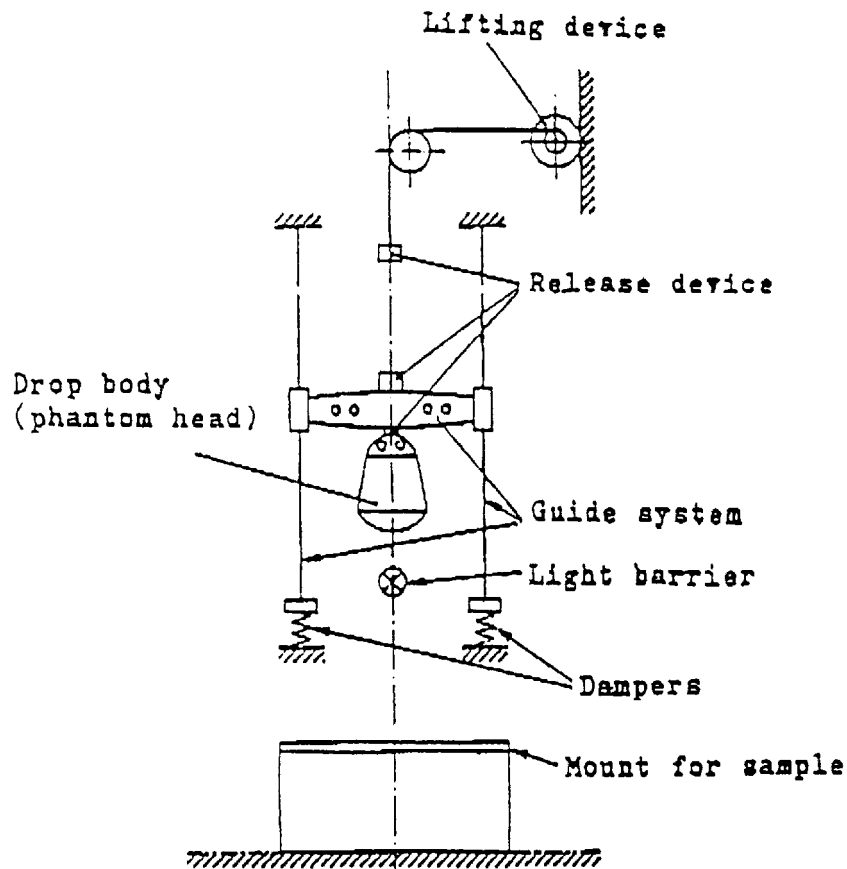

Figure 2.2

Test apparatus for the headform experiment  
with deceleration measurement

3.2.2.1. Measuring device which allows to determine HIC-values with the headform described under paragraph 3.2.1.

3.2.2.2. Equipment to calibrate the phantom head.

The drop appliance must allow drop heights between 50 mm and 254 mm

to be adjusted exactly to within 1 mm. A guide system is not necessary for these small drop heights.

A steel impact plate which is made of steel is 600 mm x 600 mm in size and at least 50 mm thick. The impact surface must be polished: surface roughness  $R_{max} = 1 \mu\text{m}$ , flatness tolerance  $t = 0.05 \text{ mm}$ .

### 3.2.2.3. Calibration and adjustment of the phantom head

Before each test series and no later than each 50 tests within a series, the phantom head must be calibrated and adjusted if necessary.

The impact plate must be clean and dry and during the test must lie non-positively on a concrete base.

The phantom head is allowed to hit the impact plate vertically. The drop heights (measured from the lowest point of the phantom head to the surface of the impact plate) are 50, 100, 150 and 254 mm. The deceleration curves should be recorded.

The greatest deceleration  $a_z$  from the various drop heights on the z-axis must lie within the limits given in the table:

Drop height mm	Greatest deceleration $a_z$ as a multiple of acceleration due to gravity g
50	$64 \pm 5$
100	$107 \pm 5$
150	$150 \pm 7$
254	$222 \pm 12$

The deceleration curves should be based on a unimodel vibration. The deceleration curve of the drop height of 254 mm must run at least 1.2 ms and at most 1.5 ms over 100 g.

If the requirements given in paragraph 3.2.2.3. are not met, the elastic properties of the phantom head must be adjusted by varying the thickness of the intermediate ring (13) in the base plate (24). Corrections can be carried out by adjusting the three self-locking hexagonal nuts (8) on the threaded bolts (16) with which the basin (18) is fixed to the base plate (24). The rubber rings (10) under the hexagon nuts (8) should not be brittle or cracked.

The cover (19) of the impact surface and the intermediate ring (13) should always be replaced immediately if damaged, especially when the phantom head can no longer be adjusted.

- 3.2.3. Supporting fixture for testing flat test pieces is as described in paragraph 3.1.3.
- 3.2.4. Test conditions are specified in paragraph 3.1.4.
- 3.2.5. Tests on complete panes (used for a drop height between 1.5 m and 3 m). Place the pane freely on a support with an interposed strip of rubber of hardness 70 IRHD and thickness of about 3 mm.

The pane shall be clamped to the supporting structure by means of appropriate devices. The surface of the pane shall be substantially perpendicular to the incident direction of the headform weight. The headform weight shall strike the pane at a point within 40 mm of its geometric centre on that face which represents the inward face of the plastic pane when the latter is mounted on the vehicle, and shall be allowed to make only one impact.

Starting from a selected initial drop height, the drop heights should be raised by 0.5 m respectively in each further experiment. The deceleration curves occurring on impact on the sample for  $a_x$ ,  $a_y$  and  $a_z$  should be recorded according to time  $t$ .

After the headform test, it should be checked whether a glazing edge has moved more than 2 mm in the mount and whether the requirement for the point of impact was met. The acceleration components  $a_x$  and  $a_y$  should be smaller for vertical impact than  $0.1 a_z$ .

#### 3.2.6. Evaluation

The deceleration curves should be evaluated as follows:

The resulting deceleration  $a_{res}(t)$  in the centre of gravity according to equation (1) from the measured deceleration curves  $a_x(t)$ ,  $a_y(t)$  and  $a_z(t)$  is to be compounded as multiples of the acceleration due to gravity.

$$(1) \quad a_{res}(t) = (a_x^2(t) + a_y^2(t) + a_z^2(t))^{1/2}$$

The time for which a deceleration of 80 g with  $a_{res}$  is continually exceeded and the greatest deceleration of  $a_{res}$  should be determined. The HIC-value should be calculated as a measurement of the danger of blunt skull-brain-injuries using the following equation (2):

$$(2) \quad HIC = (t_2 - t_1)^{-1.5} \left( \int_{t_1}^{t_2} a_{res}(t) dt \right)^{2.5}$$

The integral limits  $t_1$  and  $t_2$  should be selected in such a way that the integral takes a maximal value."

Paragraph 4.1.1., the reference to footnote 1/ and footnote 1/, renumber as footnote 2/.

Paragraph 4.1.2., the reference to footnote 1/ and footnote 1/, renumber as footnote 3/.

Paragraph 4.4.3., amend to read:

".....

For each type of safety glazing, carry out three tests with the same load. Use the haze as a measure ....."

Insert new paragraphs 6.4. to 6.4.1.5., to read:

"6.4.            Resistance to simulated weathering

6.4.1.        Test method

6.4.1.1.     Apparatus

6.4.1.1.1.   Long arc xenon lamp

The exposure apparatus 4/ shall utilize a long arc xenon lamp as the source of irradiation, but other methods giving the required level of ultraviolet radiant exposure shall be allowed. The long arc xenon lamp is advantageous in that it can, when correctly filtered and maintained, yield a spectrum most closely approximating that of natural sunlight. To this end, the quartz xenon burner tube shall be fitted with suitable borosilicate glass optical filter(s) 5/. The xenon lamps employed shall be operated, from a suitable 50 or 60 Hz power supply suitable reactance transformers and electrical equipment.

The exposure apparatus shall include equipment necessary for measuring and/or controlling the following:

- Irradiance

---

4/    Such as Atlas Ci Series, Heraeus Xenotest Series, or Suga WEL-X Series.

5/    Such as Corning 7740 Pyrex or Heraeus Suprax.



- Black standard temperature
- Water spray
- Operating schedule or cycle

The exposure apparatus shall be made from inert materials which do not contaminate the water employed in the test.

Irradiance shall be measured at the test specimen surface and shall be controlled according to the recommendations of the exposure apparatus manufacturer.

Total ultraviolet 6/ radiant exposure (Joules per square metre) shall be measured or computed and shall be considered the primary measure of test specimen exposure.

#### 6.4.1.2. Test specimens

The dimensions of the test specimen shall normally be those specified in the appropriate test method for the property or properties to be measured after exposure.

The number of control and test specimens for each test condition or exposure stage shall be determined, in addition to those required for visual evaluations by the number required by the test methods.

It is recommended that visual evaluations be conducted on the largest test specimens tested.

#### 6.4.1.3. Procedure

Measure, according to paragraph 9.1. of this annex the luminous transmission of the test specimen(s) to be exposed. Measure, according to paragraph 4 of this annex, the resistance to abrasion of the surface(s) of the control specimen(s). That face of each test specimen, which would represent the surface glazed to the exterior of the road vehicle, shall face the lamp. Other exposure conditions shall be as follows:

- 6.4.1.3.1. The irradiance shall not vary more than  $\pm 10\%$  over the whole test specimen area.
- 6.4.1.3.2. At appropriate intervals, clean lamp filters by washing with detergent and water. Xenon arc filters shall be replaced according to the recommendations of the equipment manufacturer.
- 6.4.1.3.3. The temperature within the exposure apparatus during the dry portion of the cycle shall be controlled by circulation of sufficient air to maintain a constant black standard temperature.

In the xenon arc exposure apparatus, this temperature shall be  $70 \pm 3^\circ\text{C}$  as indicated by a Black standard thermometer or equivalent.

The black panel thermometer shall be mounted in the test specimen

---

6/ Total ultraviolet is considered to be all radiation of wavelength less than 400 nm.

rack and readings shall be taken at the point where maximum heat is developed due to light exposure.

- 6.4.1.3.4. The relative humidity within the exposure apparatus shall be controlled at  $50 \pm 5\%$  during the dry portions of the cycle.
- 6.4.1.3.5. The deionized water used in the spray cycle shall contain less than 1 ppm silicon dioxide solids and shall leave no permanent deposit or residue on the test specimens which would interfere with subsequent measurements.
- 6.4.1.3.6. The pH of the water shall be between 6.0 and 8.0, and the conductivity shall be less than 5 microsiemens.
- 6.4.1.3.7. The temperature of the water in the line where it enters the exposure apparatus shall be the ambient water temperature.
- 6.4.1.3.8. The water shall strike the test specimens in the form of a fine spray in sufficient volume to wet the test specimens uniformly, immediately upon impact.

Water spray will be directed only against the test specimen surface facing the light source. No recirculation of the spray water or immersion of the test specimens in the water shall be permitted.

- 6.4.1.3.9. The test specimens shall be rotated about the arc in order to provide uniform distribution of the light. All positions in the exposure apparatus shall be filled with test specimens or surrogates to ensure that a uniform temperature distribution is maintained. Test specimens shall be held in frames with backs exposed to the cabinet environment. However, reflections from cabinet walls shall not be permitted to strike the back surface of specimens. If necessary, samples may be backed to block such reflections so long as free circulation of air at the specimen surface is not impeded.
- 6.4.1.3.10. The exposure apparatus shall be operated to provide continuous light and intermittent water spray in 2 h cycles. Each 2 h cycle shall be divided into periods during which the test specimens are exposed to light without water spray for 102 minutes and to light with water spray for 18 minutes.

#### 6.4.1.4. Evaluation

After exposure, the test specimens may be cleaned, if necessary, by a practice recommended by their manufacturer to remove any residues present.

Evaluate the exposed test specimens visually with respect to the following properties:

- Bubbles
- Colour
- Haze
- Noticeable decomposition

Measure the luminous transmission of the exposed specimens.

6.4.1.5. Expression of results

Report visual evaluations of exposed test specimens, comparing the appearance of each with that of the unexposed control.

The luminous transmittance measured must not differ from the original tests on unexposed samples by more than 5% and shall not fall below.

75% in the case of a windscreens;

70% in the case of a glazing other than a windscreen which is located in a position requisite for driving visibility."

Paragraph 7.1., amend to read:

"... and the relative humidity at  $95 \pm 4$  per cent.  
In the case of rigid plastic glazings and rigid plastic double glazed units the number of samples shall be ten.  
....."

Paragraph 9.1.1.3., the reference to footnote 1/ and footnote 1/, renumber as footnote 7/.

Paragraph 9.1.2.2., the reference to footnote 2/ and footnote 2/, renumber as footnote 8/; footnote 8/ amend to read:

"8/ As defined in the Consolidated Resolution on the Construction of Vehicles (R.E.3) (document TRANS/WP.29/78/Rev.1, annex 7).

Insert a new paragraph 10.9., to read:

"10.9. Interpretation of results."

Paragraph 10.9. (former), renumber as paragraph 10.9.1., and amend to read.

"10.9.1. Safety-glass panes faced..."

Insert a new paragraph 10.9.2., to read:

"10.9.2. Rigid plastic glazing (paragraph 2.5.1. of this Regulation), flexible plastic glazing (paragraph 2.5.2. of this Regulation) and rigid plastic double glazed units shall be considered satisfactory from the point of view of the fire-resistance test if the burn rate does not exceed 110 mm/min."

Paragraph 11.1.4., amend to read:

"11.1.4. Petrol or equivalent reference petrol: a mixture of 50% by volume toluene, 30% by volume 2,2,4-trimethylpentane, 15% by volume 2,4,4-trimethyl-1-pentene and 5% by volume ethyl alcohol;  
N.B. The composition of the petrol used shall be recorded in the test report."

Paragraphs 11.2. and 11.3., amend to read:

"11.2. Test method

11.2.1. Test procedure under load

11.2.1.1. The test specimen shall be simply supported as a horizontal level arm between a fixed supporting edge at one end in such a way that the entire width will rest on a cutting edge (fulcrum) which is 51 mm from the fixed end support. A load shall be suspended from the free end of the test specimen at a distance of 102 mm from the fulcrum as shown in figure 21 below:

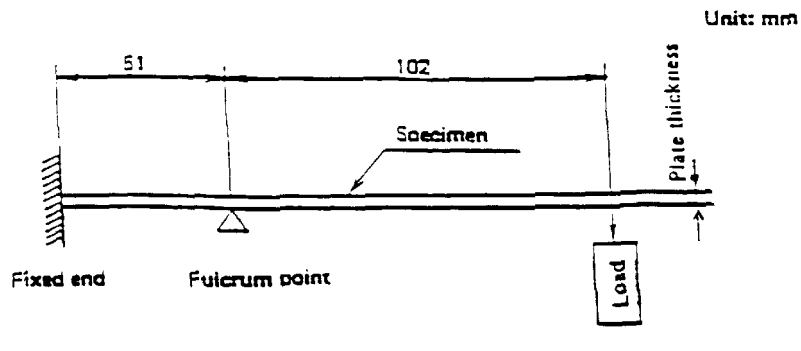

Figure 21: Method of setting up the test specimen

11.2.1.2. The load mass shall be  $28.7 t^2$  g where  $t$  is the thickness in mm of the test specimen. The resulting stress on the outer fibre of the test specimen is approximately 6.9 MPa.

Example: For a 3 mm thick test specimen placed horizontally between a downward fixed edge and an upward fulcrum edge separated by 51 mm the applied downward load at 102 mm from the fulcrum is to be 258 g.

- 11.2.1.3. While the test specimen is stressed, one of the prescribed chemicals shall be applied to the top surface of the test specimen above the fulcrum point. The chemical shall be applied with a soft, 13 mm wide brush, wetted before each stroke. Ten individual strokes at 1 s intervals across the width of the test specimen, avoiding the end and edges, shall be required (see figure 22).

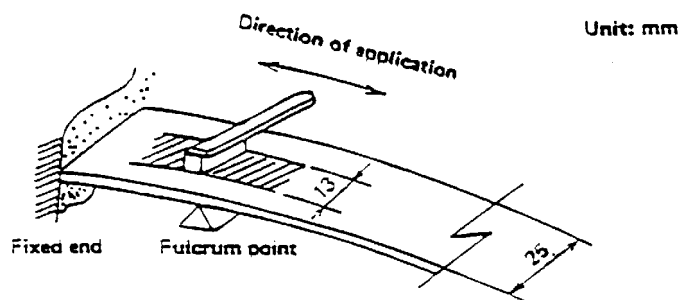

Figure 22 : Method of Applying Chemicals to the Test Specimen

- 11.3. Indices of difficulty of the secondary characteristics

	<u>Colourless</u>	<u>Tinted</u>
Colouring of the plastics coating or plastic glazing	1	2

The other secondary characteristics are not concerned."

Insert new paragraphs 12. to 13.4., to read:

"12. FLEXIBILITY TEST AND FOLD TEST

12.1. Scope

With this test has to be found out whether a plastic is to be classed into the categories of rigid or flexible plastics.

12.2. Test method

From the material of the nominal thickness a rectangular flat sample 300 mm long and 25 mm wide is cut out and horizontally clamped into a clamping device in such a way that 275 mm of the length of the sample freely extend over the holding device. This free end shall be supported horizontally by an appropriate device until the test begins. 60 seconds after removal of this support the vertical deviation of the free end is indicated in mm. If this deviation exceeds 50 mm a 180° fold test is performed subsequently. The sample is folded concisely, after that it is folded round 0.5 mm thick piece of sheet metal in such a way that

it tightly contacts it on both sides.

12.3. Test conditions

- Temperature:  $20^{\circ}\text{C} \pm 2^{\circ}\text{C}$ .
- Relative Humidity:  $60\% \pm 5\%$

12.4. Requirements

The vertical deviation must be more than 50 mm for flexible plastics, and 10 seconds after a  $180^{\circ}$  - folding the material must not show any fracture-like damages at the point of buckling (see figure 23).

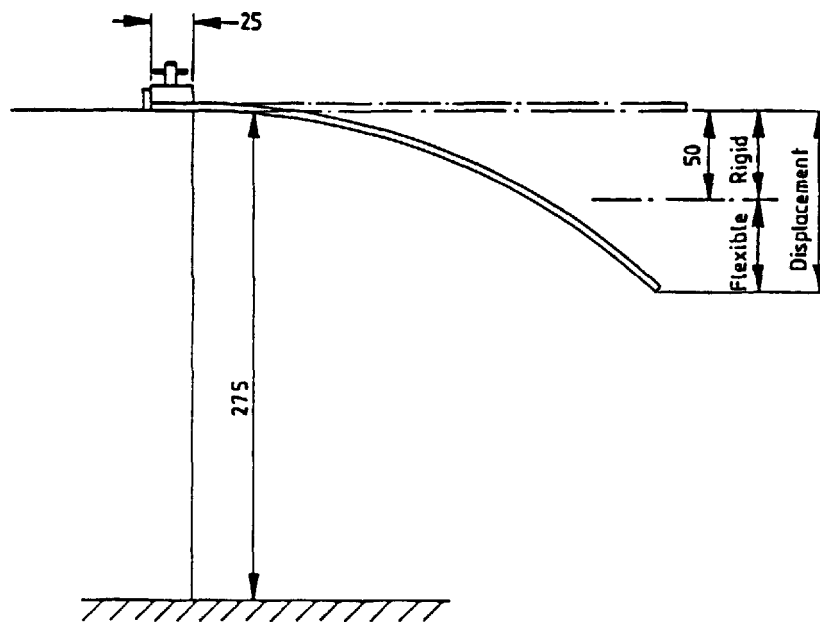

Dimensions in millimetres

Figure 23 : Arrangement of flexibility test

13. CROSS-CUT TEST

13.1. Scope

This test gives a simple method to determine the adhesion of coatings to the subsurface. The brittleness and other strength characteristics can be evaluated.

13.2. Apparatus

Cutting tool with 6 blades set at 1 mm apart. A magnifying glass with an enlargement of 2 x to examine the crosscut specimen (see figure 24).

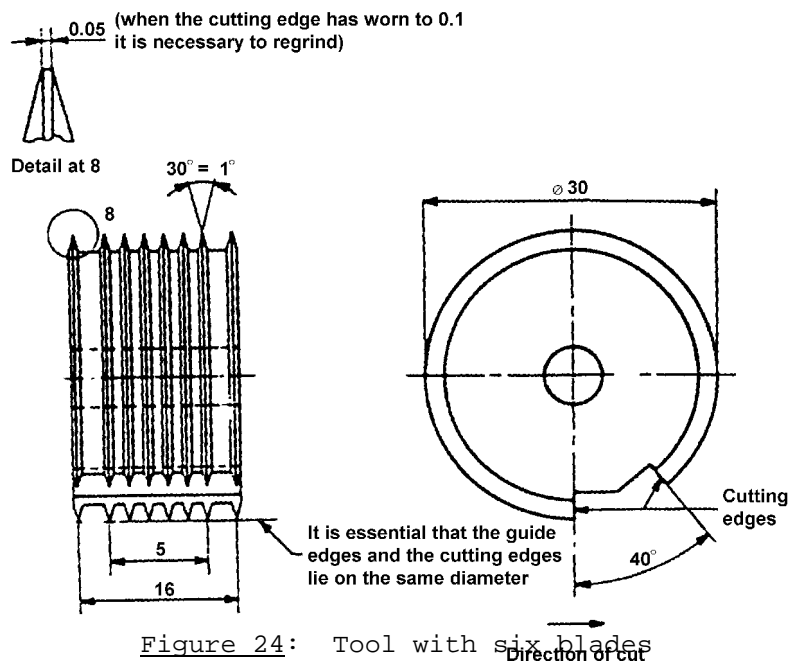

13.3. Test Method

Cut through the coating on to the subsurface a pattern with 6 cuts and perpendicular to this another one so that a grid with 25 squares arises (grid-cut).

The cutting tool should be drawn steadily with a speed of 2 to 5 cm/s so that the cuts reach the subsurface but do not penetrate too deeply.

The cutting is conducted in such a way that the two leading heads at the edge of the apparatus touch the surface uniformly. After the test the cuts are examined with a magnifying glass to check that they reach the subsurface. The test is carried out at least at two different positions of the specimen. After the cuts have been produced they are brushed 5 times with slight pressure in both diagonal directions with a hand brush with polyamide bristles.

13.4. Interpretation of Results

The grid cuts are examined with a magnifying glass. If the cut

edges are perfectly smooth and if no part of the coating is detached then it will be given a cross cut value of Gt0. If there are small fragments detached at the intersection of the cuts and if the exposed area amounts to about 5% of the grid area the cut value is Gt1.

Larger areas of detachment will be graded in the range Gt2 to Gt5.

\_\_\_\_\_ "

Annex 4,

Paragraph 1.1.1., amend to read:

"1.1.1. Trade names or marks;"

Paragraph 2.5., amend "annex 14" into "annex 17".

Paragraph 3.3.1., amend to read:

"3.3.1. The method used shall be that described in annex 3, paragraph 3.1."

Annex 5,

Paragraph 1.1.1., amend to read:

"1.1.1. Trade names or marks;"

Insert a new paragraph 1.2.4., to read:

"1.2.4. The incorporation or otherwise of obscuration bands."

Paragraph 2.5., amend "annex 14" into "annex 17".

Paragraph 2.5.1, amend "annex 14" into "annex 17".

Paragraph 4.2., amend to read:

"4.2. The provisions of paragraph 9 of annex 3 shall apply to uniformly-toughened glass panes used as windscreens of slow-moving vehicles which, by construction, cannot exceed 40 km/h. This shall not apply to flat windscreens which fall within an already approved group."



Annex 6,

Paragraph 1.1.1., amend to read:

"1.1.1. Trade names or marks;"

Paragraph 3.2.2.1., amend to read:

"3.2.2.1. The method used shall be that described in annex 3, paragraph 3.1."

Paragraph 3.3.2.1., amend to read:

"3.3.2.1. The method used shall be that described in annex 3, paragraph 3.1."

Paragraph 5.3.2., amend to read:

"5.3.2. The requirements of annex 3, paragraph 6.3. shall apply".

Paragraph 6., insert the following text at the end:

"... This shall not apply to flat windscreens which fall within an already approved group if the rake angle is less than 40° to the vertical".

Annex 7,

Paragraph 1.1.1., amend to read:

"1.1.1. Trade names or marks;"

Insert a new paragraph 1.2.4., to read:

"1.2.4. The incorporation or otherwise of obscuration bands."

Paragraph 3.3.1., amend to read:

"3.3.1. The method used shall be that described in annex 3, paragraph 3.1."

Paragraph 5.3.2., amend to read:

"5.3.2. Number of samples or test pieces

The requirements of annex 3, paragraph 6.3. shall apply."

Annex 8,

Paragraph 1.1.1., amend to read:

"1.1.1. Trade names or marks;"

Annex 10,

Paragraph 1.1.1., amend to read:

"1.1.1. Trade names or marks;"

Paragraph 3.2.2.1., amend to read:

"3.2.2.1. The method used shall be that described in annex 3, paragraph 3.1."

Paragraph 3.3.2.1., amend to read:

"3.3.2.1. The method used shall be that described in annex 3, paragraph 3.1."

Paragraph 5.3., amend to read:

"5.3. Resistance-to-radiation test

The requirements of annex 3, paragraph 6.3. shall apply."

Annex 11,

Paragraph 1.1.1., amend to read:

"1.1.1. Trade names or marks;"

Insert a new paragraph 1.2.4., to read:

"1.2.4. The incorporation or otherwise of obscuration bands."

Paragraph 3.3.1., amend to read:

"3.3.1. The method used shall be that described in annex 3, paragraph 3.1."

Paragraph 5.3., amend to read:

"5.3. Resistance-to-radiation test

The requirements of annex 3, paragraph 6.3. shall apply."

Annex 12,

Paragraph 1.1.1., amend to read:

"1.1.1. Trade names or marks;"

Paragraph 1.1.5., amend to read:

"1.1.5. The type of sealing."

Paragraph 3.3.1., amend to read:

"3.3.1. The method used shall be that described in annex 3, paragraph 3.1."

Insert new annexes 14, 15 and 16, to read:

"Annex 14

RIGID PLASTIC GLAZINGS OTHER THAN WINDSCREENS

1. DEFINITION OF TYPE

Rigid plastic glazings shall be considered to belong to different types if they differ in at least one of the following principal or secondary characteristics.

1.1. The principle characteristics are as follows:

1.1.1. Trade names or marks;

1.1.2. The chemical designation of the material.

1.1.3. The classification of the material by the manufacturer.

1.1.4. The process of manufacture.

1.1.5. The shape and dimensions.

1.1.6. The nominal thickness. The thickness tolerance limit for extruded plastic products is  $\pm 10\%$  of the nominal thickness. For plastic products produced by other techniques (e.g. cast acrylic sheet), the acceptable thickness tolerance is given by the equation (thickness tolerance limits (mm) =  $\pm (0.4 + 0.1 e)$  where e is the sheet thickness in millimetres. Reference standard is ISO 7823/1.

1.1.7. The colouring of the plastic product.

1.1.8. The nature of the surface coating.

1.2. The secondary characteristics are as follows:

1.2.1. The presence or absence of conductors or heating elements.

2. GENERAL

- 2.1. In the case of rigid plastic panes the tests shall be conducted either on flat test pieces rigorously representative of the finished product or on finished parts. All optical measurements shall be carried out on real parts.
- 2.2. The test pieces must be freed from protecting maskings and have to be cleaned carefully before the test.
- 2.2.1. They must be stored for 48 hours at a temperature of  $23^{\circ}\text{C} \pm 2^{\circ}\text{C}$  and a relative humidity of  $50\% \pm 5\%$ .
- 2.3. To describe the breaking behaviour under dynamical stress, classes will be created depending on the application of the plastics. These classes are related to contact probabilities of the human head with the plastic glazing and they contain different requirements concerning the headform test.

3. FLEXIBILITY TEST

3.1. Indices of difficulty of the secondary characteristics

No secondary characteristic is involved.

3.2. Number of test pieces

One flat test piece measuring 300 mm x 25 mm shall be subjected to testing.

3.3. Test method

- 3.3.1. The method used shall be that described in annex 3 paragraph 12.

3.4. Interpretation of results

For a test piece or sample to be considered rigid the vertical deflection of the test piece shall be less than or equal to 50 mm after 60 seconds.

4. HEADFORM TEST

4.1. Indices of difficulty of the secondary characteristics

No secondary characteristic is involved.

4.2. Number of test pieces

Six flat test pieces (1170 x 570 +0/-2 mm) or six complete parts shall be subjected to testing.

4.3. Test method

- 4.3.1. The method used shall be that described in annex 3, paragraph 3.2.
- 4.3.2. For panes like partitions and separating windows which have impact probability (classification VIII/A) the drop height shall be 3 m. The HIC value is also to be measured.
- 4.3.3. For panes like side windows, back windows and sunroofs which have

reduced impact possibilities (classification VIII/B) the drop height shall be 1.5 m. The HIC value is also to be measured.

- 4.3.4. For panes which do not have contact possibilities as well as for small windows in vehicles and for all windows in trailers (classification VIII/C) there will be no headform testing. A small window is a window into which a 150 mm diameter circle cannot be scribed.

4.4. Interpretation of results

The test shall be deemed to have given a satisfactory result if the following conditions are fulfilled:

- 4.4.1. The test piece or sample is not penetrated nor shall it break into fully separate large pieces.
- 4.4.2. The HIC value is less than 1000.
- 4.4.3. A set of test pieces submitted for approval shall be considered satisfactory from the point of view of the headform test if one of the following conditions is met:
- 4.4.3.1. All the tests give satisfactory results, or
- 4.4.3.2. One test having an unsatisfactory result, a further series of tests carried out on a new set of test pieces give satisfactory results.

5. MECHANICAL STRENGTH TEST 227 g BALL TEST

5.1. Indices of difficulty of the secondary characteristics:

- 1) without conductors or heating elements
- 2) with conductors or heating elements

5.2. Number of test pieces

Ten flat square pieces 300 +10/-0 mm or ten substantially flat finished parts shall be subjected to testing.

5.3. Test method

- 5.3.1. The method used shall be that prescribed in annex 3, paragraph 2.1.

- 5.3.2. The height of drop for the various thickness values is given in the table below:

sheet thickness (mm)	height of drop (m)
< 3	2
4	3
5	4
> 6	5

For intermediate values of test piece thickness in the interval between 3 mm and 6 mm the height of drop must be interpolated.

5.4. Interpretation of results

5.4.1. The ball test shall be considered to have given a satisfactory result if the following conditions are met:

- the ball does not penetrate the test piece
- the test piece does not break into separate pieces

As a result of the impact, cracks and fissures in the sheet are however permissible.

5.4.2. A set of test pieces submitted for approval shall be considered satisfactory from the point of view of the 227 g ball test if one of the following conditions is met:

5.4.2.1. Eight or more separate tests give a satisfactory result at the drop height.

5.4.2.2. Three or more tests having given an unsatisfactory result, a further series of tests carried out on a new set of test pieces gives satisfactory results.

5.5. 227 g ball test at  $-18^{\circ}\text{C} \pm 2^{\circ}\text{C}$ .

5.5.1. To minimize the temperature change of the test piece, the test shall be performed within 30 seconds of the removal of the test piece from the conditioning appliance.

5.5.2. The test method shall be that described in paragraph 5.3. of this annex, except that the test temperature is  $-18^{\circ}\text{C} \pm 2^{\circ}\text{C}$ .

5.5.3. Interpretation of results as in paragraph 5.4. of this annex.

6. TEST RESISTANCE TO THE ENVIRONMENT

6.1. Test of resistance to abrasion

6.1.1. Indices of difficulty and test method

The requirements of annex 3, paragraph 4 shall apply; the test is performed for either 1000, 500 or 100 cycles to measure abrasion of the surface of the product.

6.1.2. Three flat square test pieces of 100 mm for each type of surface shall be subjected to testing.

6.1.3. Interpretation of results

6.1.3.1. For safety glazings used at places which are requisite for the driver visibility, the abrasion test shall be considered to have given a satisfactory result if the total light scatter after abrasion does not exceed 2% after 1000 cycles on the outer surface of the test piece and 4% after 100 cycles on the inner surface of the test piece.

6.1.3.2. For side glazings used at places which are not requisite for the driver visibility, the abrasion test shall be considered to have given a satisfactory result if the total light scatter after abrasion does not exceed 10% after 500 cycles for outer surfaces and 4% after 100 cycles on the inner surface.

No abrasion testing is required for rigid plastic glazings for trailers and motor caravans. 1/

6.1.4. A set of samples for approval shall be considered satisfactory if one of the following conditions is met:

- all samples meet the requirements or
- one sample having failed, a repeat of the tests on a new set of samples gives a satisfactory result.

---

1/ Until "motor caravan" is defined in the Consolidated Resolution on the Construction of Vehicles (R.E.3), "motor caravan" means a special purpose M1 category vehicle constructed to include accommodation space which contains at least the following equipment:

- (i) seats and table
- (ii) sleeping accommodation which may be converted from the seats
- (iii) cooking facilities, and
- (iv) storage facilities.

This equipment shall be rigidly fixed to the living compartment; however, the table may be designed to be easily removable.

6.2. Test of resistance to simulated weathering

6.2.1. Indices of difficulty and test method

The requirements of annex 3, paragraph 6.4. shall apply. The total ultraviolet radiant exposure with the long arc xenon lamp shall be 1600 MJ/m<sup>2</sup>. During irradiation the test pieces shall be exposed to water spray in continuous cycles. During a cycle of 120 minutes the test pieces are exposed to light without water spray for 102 minutes, and to light with water spray for 18 minutes.

6.2.1.1. Other methods giving equivalent results shall be allowed.

6.2.2. Number of test pieces

Three flat test pieces 130 x 40 mm cut from a flat sheet sample shall be subjected to testing.

6.2.3. Interpretation of results

6.2.3.1. The resistance to the simulated weathering shall be considered to have given a satisfactory result if:

6.2.3.1.1. The light transmittance measured in accordance with annex 3, paragraph 9.1. does not fall below 95% of the pre-weathering value. Additionally, for windows which are required for driver visibility the value shall not fall below 70%.

6.2.3.1.2. No bubbles or other visible decompositions, discolourations, milkiness or crazing shall occur during weathering.

6.2.4. A set of test pieces or samples submitted for approval shall be considered satisfactory from the point of view of the resistance to simulated weathering if one of the following conditions is met:

6.2.4.1. All test pieces have given a satisfactory result.

6.2.4.2. One test piece having given an unsatisfactory result, a further series of tests carried out on a new set of test pieces or samples gives satisfactory results.

6.3. Cross-cut test

6.3.1. Indices of difficulty and test method

The requirements of annex 3, paragraph 13 shall apply only to coated rigid products.

6.3.2. The cross-cut test shall be carried out on one of the test pieces from paragraph 6.2.



- 6.3.3. Interpretation of results
  - 6.3.3.1. The cross-cut test shall be considered to have given a satisfactory result if:
    - 6.3.3.1.1. The cross-cut value  $G_{t1}$  is met.
  - 6.3.3.2. The test piece shall be considered satisfactory from the point of view of approval if one of the following conditions is met:
    - 6.3.3.2.1. The test has given satisfactory results.
    - 6.3.3.2.2. The test having given an unsatisfactory result, a further test carried out on another remaining test piece from test 6.2 gives satisfactory results.
- 6.4. Resistance-to-humidity test
  - 6.4.1. Indices of difficulty and test method

The requirements of annex 3, paragraph 7 shall apply.
  - 6.4.2. Ten flat square test pieces of 300 mm shall be subjected to testing.
  - 6.4.3. Interpretation of results
    - 6.4.3.1. The humidity test shall be considered to have given a satisfactory result if:
      - 6.4.3.1.1. No visible decompositions like bubbles or milkiness occur on any sample,
      - 6.4.3.1.2. and if the light transmittance measured according to annex 3, paragraph 9.1. does not fall to less than 95% of the pre-test value and additionally to no less than 70% for any window required for driver visibility.
    - 6.4.4. After testing the test pieces shall be stored for at least 48 hours at a temperature of  $23^{\circ}\text{C} \pm 2^{\circ}\text{C}$  and a relative humidity of  $50\% \pm 5\%$ , and then subjected to the 227 g ball drop test described under item 5 of this annex.
- 7. OPTICAL QUALITIES

The requirements of annex 3, paragraph 9.1. shall apply for products which are requisite for driver visibility.
- 7.1. Interpretation of results

A set of samples shall be considered as satisfactory if one of the following conditions is met:

7.1.1. All samples give a satisfactory results.

7.1.2. One sample having given an unsatisfactory result, a further set of test pieces gives satisfactory results.

8. FIRE RESISTANCE TEST

8.1. Indices of difficulty and test method

The requirements of annex 3, paragraph 10 shall apply.

8.2. Interpretation of results

The fire-resistance test shall be considered to have given a satisfactory result if the burning rate is less than 110 mm/min.

8.2.1. For the purpose of approval a set of samples will be considered satisfactory if one of the following conditions is met:

8.2.1.1. All samples give a satisfactory result.

8.2.1.2. One sample having given an unsatisfactory result a second set of samples gives satisfactory results.

9. RESISTANCE TO CHEMICALS

9.1. Indices of difficulty and test method

The requirements of annex 3, paragraph 11 shall apply.

9.2. Interpretation of results

A set of samples shall be considered acceptable if one of the following conditions is met:

9.2.1. All samples give satisfactory results.

9.2.2. One sample having given an unsatisfactory result, a second set of samples gives satisfactory results.

---

Annex 15

FLEXIBLE PLASTIC GLAZINGS OTHER THAN WINDSCREENS

1. DEFINITION OF TYPE

Flexible plastic glazings shall be considered to belong to different types if they differ in at least one of the following principal or secondary characteristics.

1.1. The principal characteristics are as follows:

1.1.1. Trade names or marks,

1.1.2. The chemical designation of the material.

1.1.3. The classification of the material by the manufacturer.

1.1.4. The process of manufacture.

1.1.5. The nominal thickness (e), a manufacturing tolerance being allowed:  $\pm (0.1 \text{ mm} + 0.1 e)$ ;  $d > 0.1 \text{ mm}$ .

1.1.6. The colouring of the plastic product.

1.1.7. The nature of the surface coating(s).

1.2. The secondary characteristics are as follows:

1.2.1. no secondary characteristic is involved.

2. GENERAL

2.1. In the case of flexible plastic glazings the tests shall be conducted on flat test pieces which either are cut from finished products or are specially produced for that purpose. In both cases the test piece must in every respect be rigorously representative for the panes which are produced in the run and for which approval is being sought.

2.2. The test pieces must be freed from protecting masks and have to be cleaned carefully before the test.

2.2.1. They must be stored for 48 hours at a temperature of  $23^{\circ}\text{C} \pm 2^{\circ}\text{C}$  and a relative humidity of  $50\% \pm 5\%$ .

3. FLEXIBILITY TEST AND FOLD TEST

3.1. Indices of difficulty of the secondary characteristics

No secondary characteristic is involved.

3.2. Number of test pieces

One flat test piece measuring 300 mm x 25 mm shall be subjected to testing.

3.3. Test method

3.3.1. The method used shall be that described in annex 3, paragraph 12.

3.4. Interpretation of results

For a test piece or sample to be considered flexible its vertical deflection shall be more than 50 mm after 60 seconds.

10 seconds after a 180° folding, the material must not show any fracture or damage at the point of bending.

4. MECHANICAL STRENGTH TESTS

4.1. Indices of difficulty of the secondary characteristics

No secondary characteristic is involved.

4.2. 227 g ball test at 20°C ± 5°C

4.2.1. Number of test pieces

Ten flat square pieces 300 +10/-0 mm shall be subjected to testing.

4.2.2. Test method

4.2.2.1. The method used shall be that prescribed in annex 3, paragraph 2.1.

4.2.2.2. The height of drop is 2 m for all thicknesses.

4.2.3. Interpretation of results

4.2.3.1. The ball test shall be considered to have given a satisfactory result if the ball does not penetrate the test piece.

4.2.3.2. A set of test pieces submitted for approval shall be considered satisfactory from the point of view of the 227 g ball test if one of the following conditions is met:

4.2.3.2.1. Eight or more tests give a satisfactory result at the height of drop.

4.2.3.2.2. More than two tests having given an unsatisfactory result at the minimum height of drop, a further series of tests carried out on a new set of test pieces gives satisfactory results.

4.3. 227 g ball test at  $-18^{\circ}\text{C} \pm 2^{\circ}\text{C}$

4.3.1. To minimize the temperature change of the test piece the test shall be performed within 30 seconds of the removal of the test piece from the conditioning appliance.

4.3.2. The test method shall be that described in paragraph 4.2.2. of this annex, except that the test piece temperature is  $-18^{\circ}\text{C} \pm 2^{\circ}\text{C}$ .

4.3.3. Interpretation of results as in paragraph 4.2.3. of this annex.

5. TEST OF RESISTANCE TO THE ENVIRONMENT

5.1. Test of resistance to simulated weathering

5.1.1. Indices of difficulty and test method

The requirements of annex 3, paragraph 6.4. shall apply. The total ultraviolet radiant exposure with the long arc xenon lamp shall be  $1600 \text{ MJ/m}^2$ . During irradiation the test pieces shall be exposed to water spray in continuous cycles. During a cycle of 120 minutes the test pieces are exposed to light without water spray for 102 minutes, and to light with water spray for 18 minutes.

5.1.1.1. Other methods giving equivalent results shall be allowed.

5.1.2. Number of test pieces

Three flat test pieces  $130 \times 40 \text{ mm}$  cut from a flat sheet sample shall be subjected to testing.

5.1.3. Interpretation of results

The resistance to the simulated weathering test shall be considered to have given a satisfactory result if:

5.1.3.1. The light transmittance measured in accordance with annex 3, paragraph 9.1. does not fall below 95% of the pre-weathering value. Additionally, for windows which are required for driver visibility the value shall not fall below 70%.

5.1.3.2. No bubbles or other visible decompositions, discolourations, milkiness or crazing shall occur during weathering.

5.1.4. A set of test pieces or samples submitted for approval shall be considered satisfactory from the point of view of the resistance to simulated weathering if one of the following conditions is met:

- 5.1.4.1. All test pieces have given a satisfactory result.
- 5.1.4.2. One test piece having given an unsatisfactory result, a further series of tests carried out on a new set of test pieces or samples gives satisfactory results.

6. OPTICAL QUALITIES

The requirements of annex 3, paragraph 9.1. shall apply for products which are requisite for driver visibility.

6.1. Interpretation of results

A set of samples shall be considered as satisfactory if one of the following conditions is met:

- 6.1.1. All samples give a satisfactory results.
- 6.1.2. One sample having given an unsatisfactory result, a further set of test pieces gives satisfactory results.

7. FIRE RESISTANCE TEST

7.1. Indices of difficulty and test method

The requirements of annex 3, paragraph 10 shall apply.

7.2. Interpretation of results

The fire-resistance test shall be considered to have given a satisfactory result if the burning rate is less than 110 mm/min.

- 7.2.1. For the purpose of approval a set of samples will be considered satisfactory if one of the following conditions is met:
  - 7.2.1.1. All samples give a satisfactory result.
  - 7.2.1.2. One sample having given an unsatisfactory result a second set of samples gives satisfactory results.

8. RESISTANCE TO CHEMICALS

8.1. Indices of difficulty and test method

The requirements of annex 3, paragraph 11 shall apply.

8.2. Interpretation of results

A set of samples shall be considered acceptable if one of the following conditions is met:

- 8.2.1. All samples give satisfactory results.

- 8.2.2. One sample having given an unsatisfactory result, a second set of samples gives satisfactory results.

---

Annex 16

RIGID PLASTIC DOUBLE GLAZED UNITS

1. DEFINITION OF TYPE

Double glazed units shall be considered to belong to different types if they differ in at least one of the following principal or secondary characteristics.

1.1. The principal characteristics are as follows:

- 1.1.1. Trade names or marks,
- 1.1.2. The chemical designation of the component sheets.
- 1.1.3. The classification of the sheets by the manufacturer.
- 1.1.4. The thickness of the component sheets.
- 1.1.5. The process of window manufacture.
- 1.1.6. The width of air gap between the component plastic sheets.
- 1.1.7. The colouring of the plastic sheets.
- 1.1.8. The nature and type of coating.

1.2. The secondary characteristics are as follows:

- 1.2.1. No secondary characteristic is involved.

2. GENERAL

- 2.1. In the case of rigid plastic double glazed units, tests will be performed on either flat test pieces or finished parts depending upon test requirements.
- 2.2. The test pieces must be freed from protecting maskings and cleaned before testing. They must be stored for 24 hours at a temperature of  $23^{\circ}\text{C} \pm 2^{\circ}\text{C}$  and a relative humidity of  $50\% \pm 5\%$  prior to testing.

- 2.3. The nominal thickness tolerance for extruded plastic products is  $\pm 10\%$  of the nominal thickness. For plastic products produced by other techniques (e.g. cast acrylic sheet), the acceptable thickness tolerance is given by the equation:

$$\text{thickness tolerance limits (mm)} = \pm (0.4 + 0.1 e)$$

where e is the sheet nominal thickness.

Reference standard is ISO 7823/1

NB: Where the thickness is not constant due to forming techniques, the measurement of the thickness will be at the geometric centre of the unit.

- 2.4. Test carried out on rigid plastic double glazed units having a nominal width of gap e measured at the geometrical centre shall be considered to be applicable to all rigid plastic double glazed units having the same characteristics and a nominal width of gap  $e \pm 5$  mm.

The applicant for approval may alternatively submit the sample having the largest and smallest nominal gaps.

### 3. FLEXIBILITY TEST

#### 3.1. Indices of difficulty of the secondary characteristics

No secondary characteristic is involved.

#### 3.2. Number of test pieces

One test piece for each component sheet of the window measuring 300 mm x 25 mm shall be subjected to testing.

#### 3.3. Test method

- 3.3.1. The method used shall be that described in annex 3, paragraph 12.

#### 3.4. Interpretation of results

The vertical deviation of both component sheets shall be less than 50 mm after 60 seconds.

### 4. HEADFORM TEST

#### 4.1. Indices of difficulty of the secondary characteristics

No secondary characteristic is involved.

#### 4.2. Number of test pieces

Six representative windows of size 1170 x 570 mm ( $\pm 2$  mm in both directions) shall be subjected to testing. The samples will have provision for peripheral clamping.

#### 4.3. Test method



- 4.3.1. the test method used shall be that described in annex 3, paragraph 3.2. impact will be on the inner side of the window.
- 4.3.2. For panes like partitions and separating windows which have high impact probability) the drop height shall be 3 m.
- The HIC value is also to be measured.
- 4.3.3. For panes like side windows, back windows and sunroofs which have reduced impact possibilities the drop height shall be 1.5 m.
- The HIC value is also to be measured.
- 4.3.4. For panes which do not have contact possibilities such as windows in trailer caravans as well as for small windows there will be no headform testing. A small window is a window into which a 150 mm diameter circle cannot be scribed.
- 4.4. Interpretation of results
- The test shall be deemed to have given a satisfactory result if the following conditions are fulfilled:
- 4.4.1. The test piece or sample is not penetrated nor shall it break into fully separate large pieces.
- 4.4.2. The HIC value is less than 1000.
- 4.4.3. A set of test pieces submitted for approval shall be considered satisfactory from the point of view of the headform test if one of the following conditions is met:
- 4.4.3.1. All the tests give satisfactory results, or
- 4.4.3.2. One test having given an unsatisfactory result, a further series of tests carried out on a new set of test pieces gives satisfactory results.
5. MECHANICAL STRENGTH TEST 227 g BALL TEST
- 5.1. Indices of difficulty of the secondary characteristics:
- No secondary characteristic is involved.
- 5.2. Number of test pieces
- Ten flat test pieces of the outer component sheet or ten finished parts of size 300 x 300 mm +10/-0 mm shall be subjected to testing.
- 5.3. Test method

5.3.1. The method used shall be that prescribed in annex 3, paragraph 2.1.

Impact will be on the outer side of the test window

5.3.2. The height of drop for the various thickness values of the outer component of the window is given in the table below:

outer sheet thickness (mm)	height of drop (m)
< 3	2
4	3
5	4
> 6	5

For intermediate values of thickness in the interval between 3 mm and 6 mm the height of drop must be interpolated.

5.4. Interpretation of results

5.4.1. The ball test shall be considered to have given a satisfactory result if the following conditions are met:

- the ball does not penetrate the test piece
- the test piece does not break into separate pieces.

5.4.2. A set of test pieces submitted for approval shall be considered satisfactory from the point of view of the 227 g ball test if one of the following conditions is met:

5.4.2.1. Eight or more separate tests give a satisfactory result at the drop height.

5.4.2.2. Three or more tests having given an unsatisfactory result, a further series of tests carried out on a new set of test pieces gives satisfactory results.

5.5. 227 g ball test at -18°C ± 2°C

5.5.1. To minimize the temperature change of the test piece, the test shall be performed within 30 seconds of the removal of the test piece from the conditioning appliance.

5.5.2. The test method shall be that described in paragraph 5.3. of this annex, except that the test temperature is -18°C ±2°C.

5.5.3. Interpretation of results as in paragraph 5.4. of this annex."

6. TEST RESISTANCE TO THE ENVIRONMENT

6.1. Test of resistance to abrasion

6.1.1. Indices of difficulty and test method

The requirements of annex 3, paragraph 4 shall apply; the test is performed for either 1000, 500 or 100 cycles to measure abrasion of the surface of the product.

6.1.2. Three flat square test pieces of 100 mm for each type of surface shall be subjected to testing.

6.1.3. Interpretation of results

6.1.3.1. For safety glazings used at places which are requisite for the driver visibility, the abrasion test shall be considered to have given a satisfactory result if the total light scatter after abrasion does not exceed 2% after 1000 cycles on the outer side of the test window and 4% after 100 cycles on the inner side of the test window.

6.1.3.2. For safety glazings used at places which are not requisite for the driver visibility, the abrasion test shall be considered to have given a satisfactory result if the total light scatter after abrasion does not exceed 10% after 500 cycles on the outer side of the test window and 4% after 100 cycles on the inner side of the test window.

No abrasion testing is required for rigid plastic double glazings for trailers and motor caravans. 1/

6.1.4. A set of samples for approval shall be considered satisfactory if one of the following conditions is met:

- All samples meet the requirements or
- one sample having failed, a repeat of the tests on a new set of samples gives a satisfactory result.

---

1/ Until "motor caravan" is defined in the Consolidated Resolution on the Construction of Vehicles (R.E.3), "motor caravan" means a special purpose M1 category vehicle constructed to include accommodation space which contains at least the following equipment:

- (i) seats and table
- (ii) sleeping accommodation which may be converted from the seats
- (iii) cooking facilities, and
- (iv) storage facilities.

This equipment shall be rigidly fixed to the living compartment; however, the table may be designed to be easily removable.

6.2. Test of resistance to simulated weathering

6.2.1. Indices of difficulty and test method

The requirements of annex 3, paragraph 6.4. shall apply. The total ultraviolet radiant exposure with the long arc xenon lamp shall be 1600 MJ/m<sup>2</sup>. During irradiation the test pieces shall be exposed to water spray in continuous cycles. During a cycle of 120 minutes the test pieces are exposed to light without water spray for 102 minutes, and to light with water spray for 18 minutes.

6.2.1.1. Other methods giving equivalent results shall be allowed.

6.2.2. Number of test pieces

Three flat test pieces 130 x 40 mm cut from the outer skin of the window shall be subjected to testing.

6.2.3. Interpretation of results

6.2.3.1. The resistance to the simulated weathering shall be considered to have given a satisfactory result if:

6.2.3.1.1. The light transmittance measured in accordance with annex 3, paragraph 9.1. does not fall below 95% of the pre-weathering value. Additionally, for windows which are required for driver visibility the value shall not fall below 70%.

6.2.3.1.2. No bubbles or other visible decompositions, discolourations, milkiness or crazing shall occur during weathering.

6.2.4. A set of test pieces or samples submitted for approval shall be considered satisfactory from the point of view of the resistance to simulated weathering if one of the following conditions is met:

6.2.4.1. All test pieces have given a satisfactory result.

6.2.4.2. One test piece having given an unsatisfactory result, a further series of tests carried out on a new set of test pieces or samples gives satisfactory results.

6.3. Cross-cut test

Indices of difficulty and test method

The requirements of annex 3, paragraph 13 shall apply only to coated products.

6.3.2. The cross-cut test shall be carried out on one of the test pieces from 6.2.

6.3.3. Interpretation of results

6.3.3.1. The cross-cut test shall be considered to have given a

satisfactory result if:

The cross-cut value  $G_{t1}$  is met.

6.3.3.2. The test piece shall be considered satisfactory from the point of view of approval if one of the following conditions is met:

6.3.3.2.1. The test has given satisfactory results.

6.3.3.2.2. The test having given an unsatisfactory result, a further test carried out on another remaining test piece from test in paragraph 6.2. gives satisfactory results.

6.4. Resistance-to-humidity test

6.4.1. Indices of difficulty and test method

The requirements of annex 3, paragraph 7 shall apply.

6.4.2. Ten square pieces or test windows of 300 x 300 mm shall be subjected to testing.

6.4.3. Interpretation of results

6.4.3.1. The humidity test shall be considered to have given a satisfactory result if:

6.4.3.1.1. No visible decompositions like bubbles or milkiness occur on any sample,

6.4.3.1.2. and if the light transmittance measured according to annex 3, paragraph 9.1. does not fall to less than 95% of the pre-test value and additionally to no less than 70% for any window required for driver visibility.

6.4.4. After testing the test pieces shall be stored for at least 48 hours at a temperature of  $23^{\circ}\text{C} \pm 2^{\circ}\text{C}$  and a relative humidity of  $50\% \pm 5\%$ , and then subjected to the 227 g ball drop test described under paragraph 5 of this annex.

7. OPTICAL QUALITIES

The requirements of annex 3, paragraph 9.1. shall apply for products which are requisite for driver visibility.

7.1. Interpretation of results

A set of samples shall be considered as satisfactory if one of the following conditions is met:

7.1.1. All samples give a satisfactory results.

7.1.2. One sample having given an unsatisfactory result, a further set of test pieces gives satisfactory results.

8. FIRE RESISTANCE TEST

8.1. Indices of difficulty and test method

The requirements of annex 3, paragraph 10 shall apply.

8.2. Interpretation of results

The test needs to be performed separately on both surfaces of the double glazed unit.

The fire-resistance test shall be considered to have given a satisfactory result if the burning rate is less than 110 mm/min.

8.2.1. For the purpose of approval a set of samples will be considered satisfactory if one of the following conditions is met:

8.2.1.1. All samples give a satisfactory result.

8.2.1.2. One sample having given an unsatisfactory result a second set of samples gives satisfactory results.

9. RESISTANCE TO CHEMICALS

9.1. Indices of difficulty and test method

The requirements of annex 3, paragraph 11 shall apply.

Testing will only be applied to samples representative of the outer face of the double glazed unit.

9.2. Interpretation of results

A set of samples shall be considered acceptable if one of the following conditions is met:

9.2.1. All samples give satisfactory results.

9.2.2. One sample having given an unsatisfactory result, a second set of samples gives satisfactory results.

\_\_\_\_\_ "

Annex 14 (former), renumber as Annex 17,

and in the caption below figure 1 amend the words "safety-glass" to read "safety glazing" (twice).

Annex 15 (former), renumber as Annex 18.

Annex 16 (former), renumber as Annex 19.

Annex 16 - Appendix 1, renumber as Annex 19 - Appendix 1.

Annex 16 - Appendix 2, renumber as Annex 19 - Appendix 2.

Annex 16 - Appendix 3, renumber as Annex 19 - Appendix 3.

Annex 17 (former), renumber as annex 20 and

Insert new paragraphs 2.8., to 2.10.2., to read:

"2.8. Rigid plastic panes other than windscreens

- 2.8.1. 227 g ball drop test in accordance with annex 14, paragraph 5.
- 2.8.2. Light transmission measurement in accordance with annex 3, paragraph 9.1.
- 2.8.3. The abrasion test in accordance with annex 14, paragraph 6.1.
- 2.8.4. Cross-cut test in accordance with annex 14, paragraph 6.3.

NB: The above test of paragraph 2.8.2. only applies if the glazing is to be used in a location requisite for driving visibility.

The above test of paragraph 2.8.4. will be carried out on samples that have not been subjected to test in accordance with paragraph 6.2. of annex 14.

- 2.9. Flexible plastic panes other than windscreens
  - 2.9.1. 227 g ball drop test in accordance with annex 15, paragraph 4.
  - 2.9.2. Light transmission measurement in accordance with annex 3, paragraph 9.1.

NB: The above test of paragraph 2.9.2. only applies if the glazing is to be used in a location requisite for driving visibility.

2.10. Rigid plastic double glazed units

- 2.10.1. 227 g ball drop test in accordance with annex 16, paragraph 5.
- 2.10.2. Light transmission measurement in accordance with annex 3, paragraph 9.1.

NB: The above tests of paragraph 2.10.2. only applies if the glazing is to be used in a location requisite for driving visibility."

Paragraph 3.6.1., amend to read

"3.6.1. Tests

Representative samples of tinted finished products shall be subjected to this test.

The check shall be carried out at least at the beginning of every production run if there is any change in the characteristics of the glazing pane affecting the results of the test.

Glazing panes having a regular light transmission measured ...."

Paragraph 3.8.1., amend to read:

"3.8.1. Tests

Plastics-surfaced, glass-plastics and plastic glazing panes only shall be submitted to this test. There shall be at least one check per month and per type of plastic material surfacing or plastic material."

Paragraph 3.9.1., amend to read:

"3.9.1. Tests

Plastics-surfaced and glass-plastics glazing panes only shall be submitted to this test. There shall be at least one check per month and per type of plastic material surfacing or plastic material."

Paragraph 3.10.1., amend to read:

"3.10.1. Tests

Plastics-surfaced, glass-plastics and plastic glazing panes only shall be submitted to this test. There shall be at least one check per month and per type of plastic material surfacing or plastic material."



Insert new paragraphs 3.11. to 3.11.2., to read:

"3.11.           Cross-cut test

3.11.1.        Tests

Only rigid plastic glazing with an abrasion resistant coating shall be submitted to this test. There shall be at least one check per week and per type of plastic material and its coating, on samples that have not been subjected to the test for simulated weathering (annex 14, paragraph 6.2.).

A test on weathered samples shall be carried out each 3 months.

3.11.2.        Results

All results shall be recorded."

---