

Proposal for a Mutual Resolution No.4 (M.R.4) of the 1958 and the 1998 Agreements concerning Panoramic Sunroof Glazing (PSG)

The text was produced by the Informal Working Group on PSG. It is submitted to the Working Party on General Safety provisions (GRSG) for review and potential adoption at its 117th session in October 2019.

The work done by the IWG on PSG is according to the authorization set in ECE/TRANS/WP.29/AC.3/41.

Mutual Resolution No.4 (M.R.4) of the 1958 and the 1998 Agreements concerning Panoramic Sunroof Glazing (PSG)

Contents

	<i>Page</i>
I. Statement of technical rationale and justification.....	2
A. Introduction	2
B. Background.....	2
C. Technical rationale and justification.....	3
1. Glass Breakage	3
2. CPA Limitation	4
II. Text of the Mutual Resolution.....	4
A. Introduction	4
B. Scope and application.....	5
C. General provisions	5
D. Specific provisions.....	5
E. Definitions	6
F. Abbreviations.....	7
Annexes	
I. PSG breakage data from Korea and USA	7
II. Data samples of Panoramic Sunroof Glazing CPA	7
III. Cases of CPA changes in Korea.....	7

I. Statement of technical rationale and justification

A. Introduction

1. This Mutual Resolution does not hold regulatory status within Contracting Parties. It is recommended that Contracting Parties and Manufacturers refer to this Mutual Resolution when designing the Ceramic Printed Area (CPA) of Panoramic Sunroofs (PS) and verifying the measurement methods hereto.

2. Sunroofs and especially Panoramic Sunroofs with more than one glass pane are today widely used in global vehicle production. Commonly the Panoramic Sunroofs are designed and manufactured with toughened safety glass panes: the Panoramic Sunroof Glazing (PSG).

Due to technical requirements and design purposes a ceramic layer is necessary to be printed onto the lower side of the toughened safety glass panes of Panoramic Sunroofs, so that a certain amount of each single toughened safety glass pane is covered with Ceramic Printed Area.

3. The Ceramic Printed Area of today reduces in general the mechanical strength of toughened safety glazing. This indicates a higher risk of complete toughened safety glass pane breakage in case of an unidentified impact (e.g. gravel, stone). In case such impacted toughened safety glass pane of a PS can be touched from inside of the vehicle, a downfall of toughened safety glazing pieces into the vehicle passenger area is possible. Due to the standards of safety glazing requirements the risk of serious injuries of vehicle passengers is very low, which is confirmed by government statistics available. Today more and more vehicles are equipped with Panoramic Sunroofs, which have larger toughened safety glass panes due to the wish of having improved design, more light and a panoramic view in the vehicle. Although the total numbers of PS is increasing globally, the quantity of PSG breakages is very low.

4. This Mutual Resolution supports the efforts to reduce the risk of toughened safety glass pane breakage in case of an unidentified impact by recommending limitations to the CPA of the PSG, which might result in a downfall of glass pieces into the vehicle passenger area in case of a glass pane breakage.

5. Some countries throughout the world have started to review on national level the possibility to reduce the CPA of the PS without additional legal regulations. As the PSG glass breakage risk is not limited to specific countries there is the need for a global approach to homogenise global practices.

6. This Mutual Resolution outlines the provisions and proposes the procedures for the limitation of CPA and respective measurements, taking into account existing standards as well as state of the art design and manufacturing technologies. It will encourage manufacturers to adapt the future design of CPA on PSG to meet this recommendation.

7. Experts also have an interest in global harmonisation since it offers more efficient development, adaptation to technical progress and potential collaboration. It also facilitates the exchange of information between interested parties.

B. Procedural Background

8. The authorization to develop amendments to UN GTR No.6 (Safety glazing) was adopted by the Executive Committee (AC.3) of the 1998 Agreement at its March 2015 session (ECE/TRANS/WP.29/1114, para. 115). It is based on ECE/TRANS/WP.29/2015/42. It endorsed the proposed action plan to establish an Informal Working Group (IWG) on PSG.

9. The aim was to develop an amendment to relevant parts of UN GTR No.6 and UN Regulation No.43, if necessary so that appropriate methods could be clarified for testing and evaluating Panoramic Sunroof Glazing.

10. The IWG should, at a first stage, collect information to clearly understand the reasons for glass breakage.

11. Parallel to this, additional review and activities should be done to verify the impact of CPA in part areas of vehicle glass in order to establish testing programs and develop recommendations.

12. The IWG on PSG under the Working Party on General Safety (GRSG) reported that PSG breakage can happen based on several factors, none of which could be identified as the single possible source. These include one-time manufacturing or human errors, vehicle and/or roof system design flaws, miss-assemblies or a massive sudden local load-case due to an undefined impact with a sharp, hard and large indenter of high impulse, among various others.

13. The IWG determined that PSG breakage itself does not usually cause serious injuries to the occupants of the vehicle, but this event might trigger other potential incidents to occur as a result of the breakage.

14. The proposed Mutual Resolution (M.R.4) provides guidance to limit the CPA of a possibly affected single toughened safety PSG pane and the measurement procedure proposals for CPA.

C. Technical rationale and justification

15. This section introduces the main working items discussed and the technical rationale for developing a harmonized design guideline for establishing a maximum size of the CPA on each single toughened safety glass pane of a PS, which is touchable from inside passenger's area.

1. Glass Breakage

16. The IWG on PSG found at a first analysis that there was a risk of glass breakage, if a PSG is part of the vehicle and special load cases occur. Nevertheless the risk of injury to the vehicle occupants through a glass breakage (such as scratches and cuts) is rather small compared to delivered volumes of sunroofs.

17. Analysis also showed that the risk of glass breakage increased, if the toughened safety glass pane was hit in a ceramic printed area instead of the clear glass area without CPA underneath. This led the IWG on PSG to the conclusion that both the CPA area and testing requirements should be reviewed.

18. Based on the available information on glass behaviour it was agreed that for a testing requirement amendment to relevant parts of UN Regulation No.43 and UN GTR No.6 long-term studies on PSG breakage would be necessary.

19. Among the possibilities explaining a regional increase in the number of breakages of PSG are: the increased global adoption of PSG's; an increased awareness; and an increased use of CPA in state of the art PSG design.

20. The development of new enamels, which do not affect the mechanical strength of the toughened safety glass while meeting all other required glass specifications might reduce the probability of toughened safety glass breakages. However, these are not available in the near

future in the required quality and quantity to meet the specifications and general needs of vehicle manufacturers.

2. CPA Limitation

21. The IWG on PSG supports that a CPA limitation should only affect glass panes of the PSG in the overhead zone, which reach into the design glass outline area.

22. In case of measuring the width of the ceramic print according to II.3.1 the ceramic print measurement should include the dotted area, but no markings or other ceramic prints.

23. In case of a percentual specific limitation of CPA according to II.3.2. all ceramic prints should be included such as markings, dotted areas and other ceramic prints such as logos.

24. It is assumed and confirmed in general that a CPA of today will reduce the mechanical strength of toughened safety glazing in any kind of glass application.

25. It is also assumed in general that in the automotive industry dynamic load cases in terms of impacts of undefined specification during the lifetime movements of a vehicle are likely to happen.

26. It was agreed in the IWG on PSG that a reduction of CPA during serial production of Panoramic Sunroofs and vehicles is not an easy task and should be done preferably with a new PSG product design for a new model launch.

27. An adaptation of the technical requirements for an amendment to relevant parts of UN Regulation No.43 and UN GTR No.6 should be based only on scientific knowledge.

28. The research required for this would take more time to produce insights into the adaptation of the 227g ball test, the CPA and possible connecting issues between both aspects.

29. There were lively discussions in the IWG on PSG based on the information above and the expectation that a change in regulations with regards to CPA limitation may not be acceptable for all members in due time.

30. Therefore it was decided in the IWG on PSG that a Recommendation with this Mutual Resolution would be a good intermediate solution until new technologies are made available.

31. To answer the question how a limitation of CPA on a toughened safety glass pane should be defined, the intense technical discussions within the IWG on PSG finally concluded, that the state of art materials, the respective design requirements and manufacturing technology limitations need to be taken into account.

32. The discussion on the variety of target CPA values (nominal and %) within the expert group concluded into the agreement on limiting the width and percentual CPA.

II. Text of the Mutual Resolution

A. Introduction

1. The Ceramic Printed Area (CPA) ensures the lifetime of the adhesion between the toughened safety glass pane and the vehicle or panoramic sunroof structure, but could reduce the strength of toughened safety glass.

2. In October 2019, the IWG on PSG prepared a recommendation to limit the size of CPA for the case of ceramic printed coatings, which reduce the strength of the toughened

safety glass to the extent that a fully-printed test piece would not withstand the UN GTR No.6 ball drop test.

B. Scope and application

3. This Mutual Resolution contains the provisions and harmonised test procedures for the maximum measurement of CPA of each single toughened safety glass pane of a Panoramic Sunroof, which is touchable from inside the passenger area.

4. This Mutual Resolution applies to category 1-1 vehicles of Special Resolution No.1, which have or may have a PS.

C. General Provisions

5. Contracting Parties are invited to refer to this Mutual Resolution for the limitation of CPA of each single toughened safety glass pane of a PS, which is touchable from inside the passenger area.

6. This Mutual Resolution does not hold regulatory status within Contracting Parties. It is recommended that Contracting Parties and Manufacturers refer to this Mutual Resolution when designing the CPA of PS and verifying the measurement methods hereto.

D. Specific Provisions

7. Following the decisions in the IWG, the manufacturers are asked to limit the maximum size of such CPA for the use on toughened safety glass for PSG:

- Each single glass pane which is touchable from inside passenger compartment shall be limited to a maximum measured, summed-up width of 125mm on each side (front, rear, left and right).
- In case that this limitation to a maximum width of 125mm on any side of the glass pane cannot be achieved due to technical restrictions or requirements, the CPA widths of any of these sides may exceed the limitation of 125mm, if the total proportion of the CPA for this single pane remains below a maximum of 45%.

8. The IWG recognizes that this Mutual Resolution to modify the ceramic print design requirements of panoramic sunroofs for vehicles cannot be implemented into vehicle applications immediately.

9. Contracting parties will understand that the orderly implementation of new sunroof glazing designs to address this guidance must be introduced into the manufacturers product portfolio early in the design process.

10. Worldwide vehicle manufacturers, component suppliers and sub-suppliers will require ample design time to integrate this Mutual Resolution into the vehicle application successfully.

11. Therefore the IWG also recommends that contracting parties implementing the provisions should not mandate full compliance upon publication of these provisions, but allow a minimum 3 (three) year phase in process to accommodate the natural vehicle design cycle.

12. In addition, vehicles types already in the specific markets at the time of publication should be unaffected by the new provisions and allowed to continue being marketed.

E. Definitions

For the purpose of this Mutual Resolution, the following definitions apply:

13. The width of maximum 125mm is defined as the summed-up dimension of ceramic printed areas measured in a 90° angle from any point on the edge of each side of the respective toughened safety glass pane on the inner surface, which is outside of the 125mm cross-over corner area (green marked area below).

In case of measuring the width of the ceramic print, the ceramic print measurement should include the dotted area, but no markings or other ceramic prints.

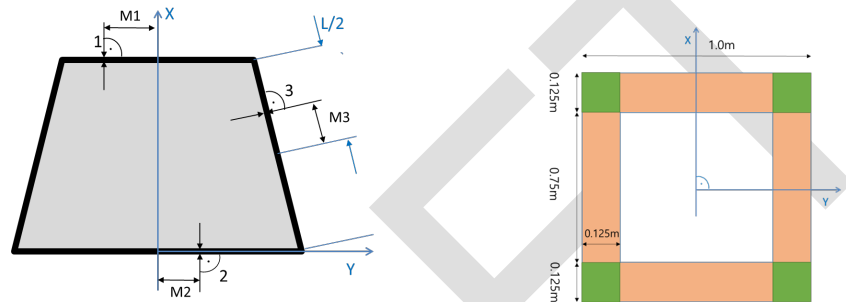

Position	max. CPA width*	Mx
1	[xx] mm	[xx] mm
2	[xx] mm	[xx] mm
3	[xx] mm	[xx] mm

Mx: point where the max. CPA width is measured from middle glass

*: including dotted area

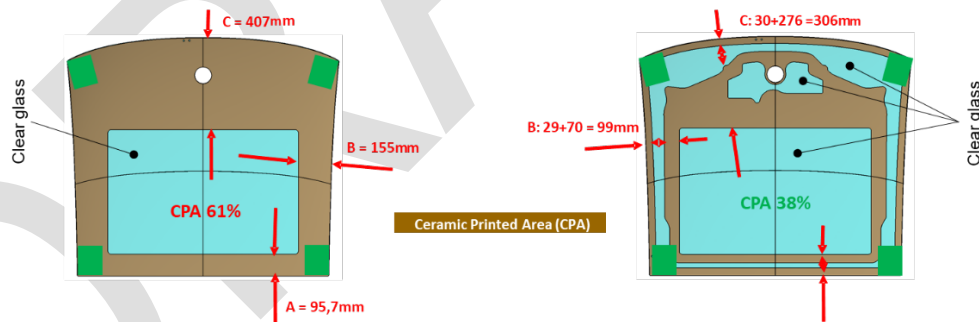

Example of CPA measurement as complete print (left side) or as sum-up of CPA stripes (right side)

14. The maximum percentage value of 45% is defined as the maximum proportion of CPA on the respective toughened safety glass pane in relation to the total size of the respective glass pane, excluding any additional glass edge covering manners (e.g. Tape, Sealing, Encapsulation, etc).

In case of a percentual specific limitation of CPA all ceramic prints should be included such as markings, dotted areas and other ceramic prints such as logos.

For the determination of the ceramic printed %-area CAD data should be the reference.

15. A PS in the context of this Mutual Resolution is defined as a vehicle integrated sunroof with one or more panes, which can be applied in a fixed or moveable manner.

F. Abbreviations

PSG	Panoramic Sunroof Glazing
IWG	Informal Working Group
CPA	Ceramic Printed Area
PS	Panoramic Sunroof

Annex I

PSG breakage data from Korea and USA

https://wiki.unece.org/download/attachments/26902754/PSG-02-04-Overall_Review_of_CPA.pdf?api=v2

https://wiki.unece.org/download/attachments/28213736/PSG-03-09_NHTSA%20panoromic%20sunroof%20incidents%20%283rd%20GRSG%20IWG%20on%20PSG%20-%2024Feb2016%29.pdf?api=v2

Annex II:

Data analysis of Panoramic Sunroof Glazing CPA

<https://wiki.unece.org/download/attachments/87621864/PSG-WEBEX%202019-02%20CPA%20data%20review-V2.pdf?api=v2>

<https://wiki.unece.org/download/attachments/80381010/PSG-11-05%20Analysis%20on%20Ceramic%20Printed%20Area%20data%20by%20ROK.pdf?api=v2>

Annex III

Cases of CPA changes in Korea

https://wiki.unece.org/download/attachments/62226910/PSG-10-02_Ceramic%20printed%20area%20changes%20cases%20in%20Korea%288Oct%29.pdf?api=v2