



---

**Economic Commission for Europe****Inland Transport Committee****World Forum for Harmonization of Vehicle Regulations****Working Party on General Safety Provisions****117th session**

Geneva, 8-11 October 2019

Item 9 of the provisional agenda

**UN Regulation No. 58 (Rear underrun protective devices)****Proposal for a Supplement to the 03 series of amendments to  
UN Regulation No. 58****Submitted by the expert from the International Organization of Motor  
Vehicle Manufacturers\***

The text reproduced below was prepared by the expert from the International Organization of Motor Vehicle Manufacturers (OICA) to introduce the aerodynamic device in the UN Regulation No. 58. Aerodynamic devices at the rear end of the vehicle shall not compromise the functionality of rear underrun protection devices. The modifications to the current text of UN Regulation No. 58 are marked in bold for new or strikethrough for deleted characters.

**A. Proposal**

*Insert new paragraph 3.1.5., to read:*

**“3.1.5. “Aerodynamic devices” means devices that are designed to reduce aerodynamic drag of road vehicles. The aerodynamic devices to vehicles consist in adds-on that, due to their design, may protrude beyond the outermost part of the vehicles at the back or laterally.”**

*Paragraph 16.4., amend to read:*

**“16.4. For vehicles of categories M, N<sub>1</sub>, N<sub>2</sub> with a maximum mass not exceeding 8 t, O<sub>1</sub> and O<sub>2</sub>, the device shall be so fitted that the horizontal distance between the rear of the cross-member of the device and the most rearward point at the rear extremity of the vehicle, including any platform lift system, does not exceed**

---

\* In accordance with the programme of work of the Inland Transport Committee for 2018–2019 (ECE/TRANS/274, para. 123 and ECE/TRANS/2018/21/Add.1, Cluster 3.1), the World Forum will develop, harmonize and update UN regulations in order to enhance the performance of vehicles. The present document is submitted in conformity with that mandate.



400 mm diminished by the largest total deformation including both plastic and elastic deformation (paragraph 7.3. of Part I) measured and recorded during the test at any of the points where the test forces are applied (Annex 1, item 8) during the type approval of the rear underrun protective device in conformity with the provisions of Part I of this Regulation and recorded in the type approval communication form. In measuring this distance, any part of the vehicle which is more than 2 m above the ground for every loading condition of the vehicle shall be excluded.

For vehicles of categories N<sub>2</sub> with a maximum mass exceeding 8 t, N<sub>3</sub>, and vehicles of categories O<sub>3</sub> and O<sub>4</sub>, equipped with a platform lift or being designed as a tipping trailer, the same requirement as above applies; however, for vehicles of these categories, the horizontal distance shall not exceed 300 mm measured to the rear of the cross-member before the test forces are applied.

For vehicles of categories O<sub>3</sub> and O<sub>4</sub>, without any platform lift system and not being designed as a tipping-trailer, the maximum horizontal distances are reduced to 200 mm before the test forces have been applied and 300 mm diminished by the largest total deformation including both plastic and elastic deformation (paragraph 7.3. of Part I) measured and recorded during the test at any of the points where the test forces are applied (Annex 1, item 8).

In any case non-structural protrusions such as tail lamps and those of less than 50 mm of size in any direction, such as rubber bumpers, resilient buffers, hinges and latches shall be excluded from the determination of the most rearward point at the rear extremity.

**In any case aerodynamic devices that comply with the provisions in annex 8 shall be excluded from the determination of the most rearward point at the rear extremity.**

Before the application of the test forces, the maximum allowed horizontal distance of a single, a segmented or an inclined cross-member of a RUPD is 100 mm between the rear of the cross-member measured at the most forward point and the rear of the cross-member measured at the most rearward point, measured in the longitudinal plane of the vehicle.”

*Paragraph 25.3., amend to read:*

“25.3. For vehicles of categories M, N<sub>1</sub>, N<sub>2</sub> with a maximum mass not exceeding 8 t, O<sub>1</sub> and O<sub>2</sub>, the RUP shall be situated as close to the rear of the vehicle as possible. The maximum horizontal distance between the rear of the device and the most rearward point at the rear extremity of the vehicle, including any platform lift system, does not exceed 400 mm measured to the rear of the cross-member and recorded during the test when the test forces are applied.

For vehicles of categories N<sub>2</sub> with a maximum mass exceeding 8 t, N<sub>3</sub>, and vehicles of categories O<sub>3</sub> and O<sub>4</sub>, equipped with a platform lift or being designed as a tipping trailer, the same requirement as above applies; however, for vehicles of these categories, the horizontal distance shall not exceed 300 mm measured to the rear of the cross-member before the test forces are applied.

For RUP for vehicles of categories O<sub>3</sub> and O<sub>4</sub>, without any platform lift system and not being designed as a tipping-trailer, the maximum horizontal distance is reduced to 200 mm before and 300 mm during the test when the test forces are applied.

In any case non-structural protrusions such as tail lamps and those of less than 50 mm of size in any direction, such as rubber bumpers, resilient buffers, hinges and latches shall be excluded from the determination of the most rearward point at the rear extremity.

**In any case aerodynamic devices that comply with the provisions in Annex 8 shall be excluded from the determination of the most rearward point at the rear extremity.**

Before the application of the test forces the maximum allowed horizontal distance of a single, a segmented or an inclined cross-member of a RUPD is 100 mm between the rear of the cross-member measured at the most forward point and the rear of the cross-member measured at the most rearward point, measured in the longitudinal plane of the vehicle.”

*Insert new Annex 8., to read:*

## “Annex 8

### Aerodynamic devices

#### 1. Purpose

The purpose of this test is to verify whether the aerodynamic device in the event of a collision with the rear of the vehicle or the vehicle combination is compromising the rear underrun protection.

#### 2. General specifications

2.1. The external surface of aerodynamic devices shall not exhibit, directed outwards, any pointed or sharp parts or any projections of such shape, dimensions, direction or hardness as to be likely to increase the risk or seriousness of bodily injury to a person hit by the external surface or brushing against it in the event of a collision.

2.2. The external surface of vehicles shall not exhibit, directed outwards, any part likely to catch on pedestrians, cyclists or motor cyclists.

2.3. Protruding parts of the external surface of an aerodynamic device shall not have a radius of curvature less than 2.5 mm. Those parts of the external surface of an aerodynamic device which are so located that, in their folded or retracted condition as well as when in operation, they cannot be contacted by a sphere 100 mm in diameter, may have a radius of curvature less than 2.5 mm. This requirement shall not apply to parts of the external surface which protrude less than 5 mm, but the outward facing angles of such parts shall be blunted, save where such parts protrude less than 1.5 mm.

2.4. Protruding parts of the external surface, made of a material of hardness not exceeding 60 shore A, may have a radius of curvature less than 2.5 mm. The hardness measurement shall be taken with the component as installed on the vehicle. Where it is impossible to carry out a hardness measurement by the Shore A procedure, comparable measurements shall be used for evaluation.

#### 3. Test conditions for aerodynamic devices

3.1. At the request of the manufacturer the test may be conducted either:

3.1.1. On a vehicle of the type for which an aerodynamic device is intended; in this case the test conditions set out in paragraph 4. below shall be observed; or

3.1.2. On a part of the body of the vehicle type for which the aerodynamic device is intended; this part shall be representative of the vehicle type(s) in question; or,

3.1.3. On a rigid wall.

3.2. In the case of paragraph 3.1.2. and 3.1.3., the parts used to connect the aerodynamic devices to a part of the vehicle body or to a rigid wall shall be equivalent to those which are used to secure the aerodynamic devices when it is installed on the vehicle. Every device shall be accompanied by installation and operating instructions giving sufficient information for any competent person to install it correctly.

- 3.3. At the request of the manufacturer the test procedure described in paragraph 5. may be simulated by calculation.

The mathematical model shall be validated in comparison with the actual test conditions. To that effect, a physical test shall be conducted for the purposes of comparing the results obtained when using the mathematical model with the results of a physical test. Comparability of the test results shall be proven. A validation report shall be drafted by the manufacturer.

Any change made to the mathematical model or to the software likely to invalidate the validation report shall require a new validation process to be conducted.

4. Test conditions for vehicles

- 4.1. The vehicle shall be at rest on a level, flat, rigid and smooth surface.
- 4.2. The front wheels shall be in the straight ahead position.
- 4.3. The tyres shall be inflated to the pressure recommended by the vehicle manufacturer.
- 4.4. The vehicle is unladen.
- 4.5. The vehicle may, if necessary to achieve the test force required in paragraph 5.1.2. below, be restrained by any method. This method is to be specified by the vehicle manufacturer.
- 4.6. Vehicles equipped with hydropneumatic, hydraulic or pneumatic suspension or a device for automatic levelling according to load shall be tested with the suspension or device in the normal running condition specified by the manufacturer.

5. Test procedure

- 5.1. The aerodynamic device shall offer a certain level of deformation to forces applied parallel to the longitudinal axis of the vehicle. Alternatively, the device may also be folded or retracted under the influence of force. The test shall be verified by means of suitable test mandrels. The device used to distribute the test force over the stated flat surface shall be connected to the force actuator through a swivel joint. In cases of geometric incompatibilities, it is recommended to use an adaptor instead of a device with a flat surface.

- 5.1.1. A force shall be applied parallel to the longitudinal axis of the vehicle via a surface not more than 250 mm in height and 200 mm wide with a radius of curvature of  $5 \pm 1$  mm at the vertical edges or an adaptor. The surface or adaptor shall not be rigidly fixed to the aerodynamic device and shall be articulated in all directions. When the test is carried out on a vehicle the height of the centre of the surface or adaptor shall be defined by the manufacturer in an area between the lowest edge of the aerodynamic device and a point no more than 2.0 meters above the ground in vehicle-mounted condition (see figure 1). This point is to be defined on a laden vehicle with the technically permissible maximum laden mass.

When the test is carried out on a part of the body of the vehicle type or on a rigid wall the height of the centre of the surface or adaptor shall be defined by the manufacturer in an area between the lowest edge of the aerodynamic device and the point that represents the height of no more than 2.0 meters above the ground in vehicle-mounted condition on a laden vehicle with the technically permissible maximum laden mass (see figure 2).

The exact location of the centre of the surface or adaptor in the area of application of forces shall be specified by the manufacturer. In cases where the aerodynamic device has different stiffness's in the area of application of forces (e.g. due to reinforcements, different materials or thicknesses etc.) the location of centre of the surface or adaptor is to be defined in the area with

the highest resistance against external forces in longitudinal direction of the vehicle.

Figure 1

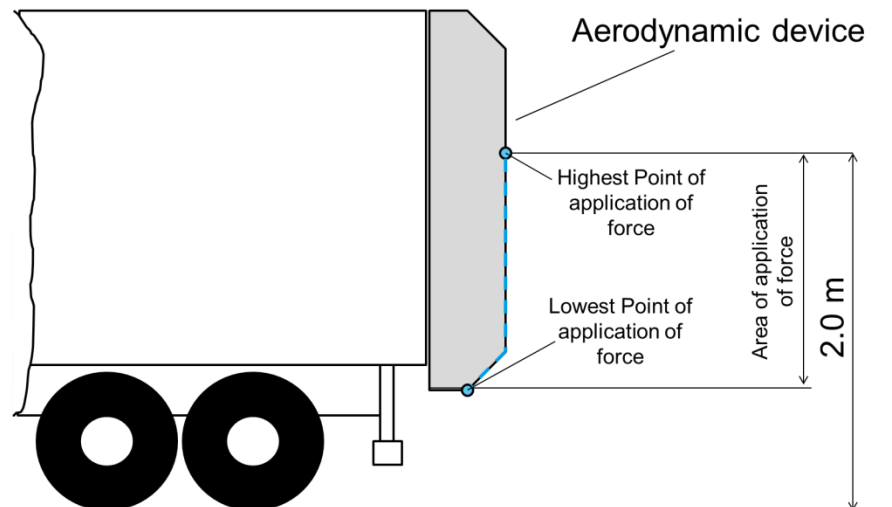
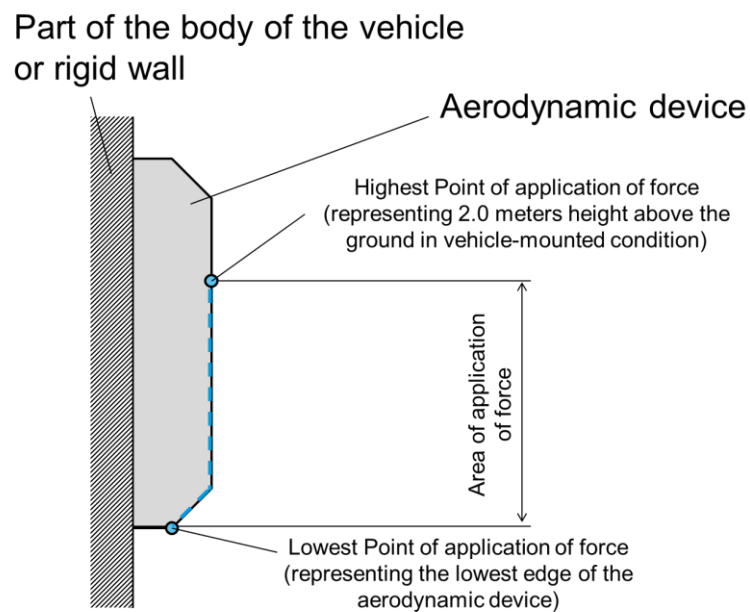
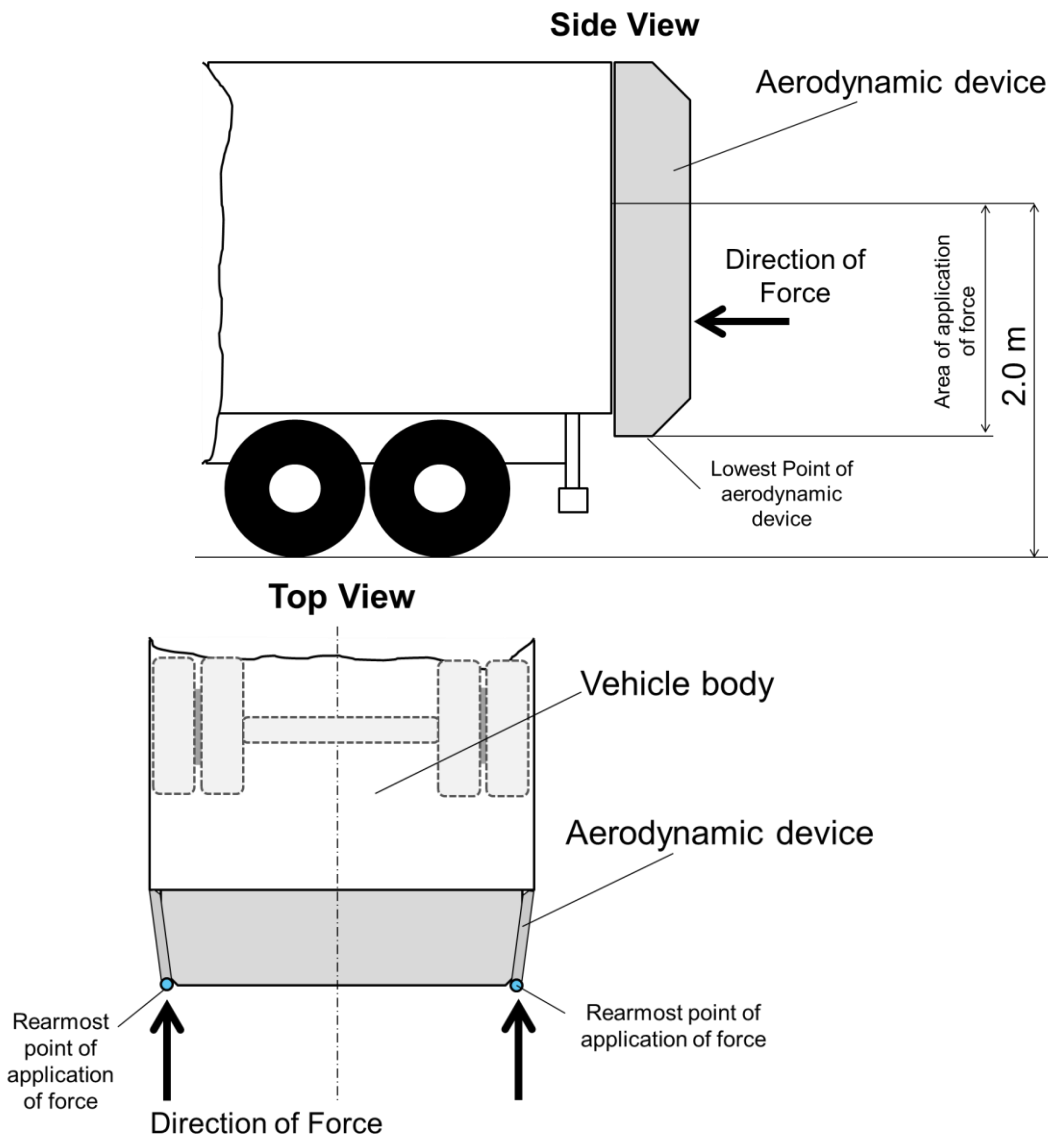

Figure 2



- 5.1.2. A horizontal force of maximum  $[4000] \text{ N} \pm 400 \text{ N}$  shall be applied consecutively to two points situated symmetrically about the centre line of the vehicle or the centre line of the device on the rearmost outer edge of the aerodynamic device in completely unfolded or not retracted condition (see figure 3). The order in which the forces are applied may be specified by the manufacturer.

Figure 3



**6. Requirements**

**6.1.** The aerodynamic device shall be so fitted that during the application of the test forces as specified in paragraph 5.1.2 this aerodynamic device has at the point of application of forces an elastic and/or plastic deformation with a maximum remaining length of 200 mm in longitudinal direction of the vehicle.

This requirement is also deemed to be fulfilled if the aerodynamic device will be folded or retracted under influence of test forces as specified in paragraph 5.1.2 so that the aerodynamic device has in this folded or retracted position a maximum remaining length of 200 mm in longitudinal direction of the vehicle.

**6.2.** Notwithstanding the provisions in paragraph 5.1., 5.1.1., 5.1.2. and 6.1. the application of forces shall not be conducted if the aerodynamic device is made of a material of hardness not exceeding 60 shore A in the area 1 regarding figure 4. Components (fastenings, hinges, actuators, springs, cables, lamps etc.) used to install the aerodynamic device on the body of the vehicle or that are mounted on the aerodynamic device are exempted from these provisions.

The hardness measurement shall be taken with the aerodynamic device as installed on the vehicle. Where it is impossible to carry out a hardness measurement by the Shore A procedure, comparable measurements shall be used for evaluation.

Figure 4

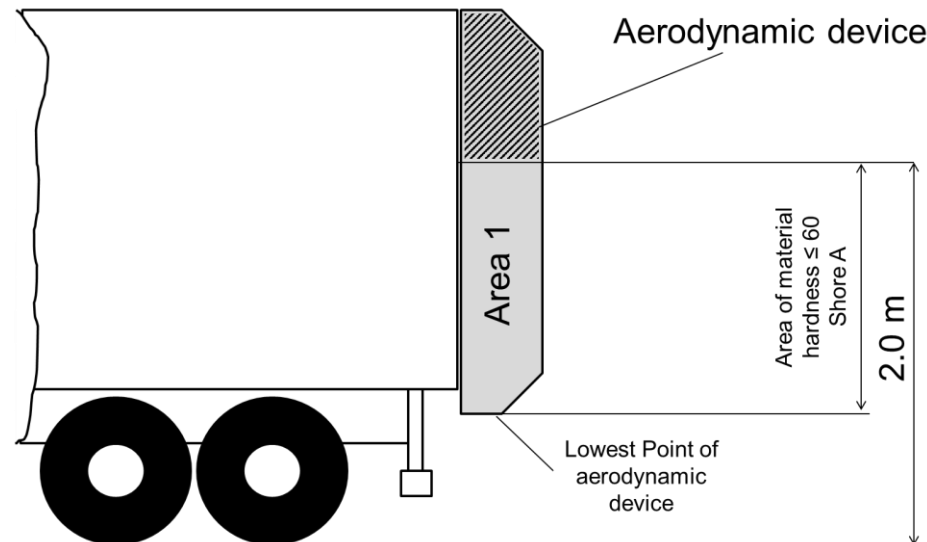

## 7. Marking

7.1. There shall be affixed to the aerodynamic device a clearly legible and indelible marking consisting of:

- (a) A serial number;
- (b) Name of device;
- (c) Name of manufacturer;
- (d) The marking "In accordance to UN Regulation No. 58" and year/month of conformity (e.g. 2018/01)."

## B. Justification

1. The European Directive 96/53 (EC) describes requirements regarding the maximum authorised dimensions in national and international traffic and the maximum authorised weights in international traffic. In the revision (EU) 2015/719, published in May 2015) it was described that technological developments make it possible to attach retractable or foldable aerodynamic devices to the rear of vehicles. The improved aerodynamics of the vehicle is urged by the need to reduce greenhouse gas emissions, particularly carbon dioxide (CO<sub>2</sub>) emissions.

2. The current draft amendment for regulation (EU) No 1230/2012 with regard to type-approval requirements for masses and dimensions of motor vehicles and their trailers describes in Appendix 1 Table 1 and Table 2 devices and equipment that are not required to be taken into account for the determination of the outermost dimensions. It is defined that foldable devices and equipment designed to reduce aerodynamic drag are exempted from the determination of the outermost length of the vehicle and the vehicle width shall not exceed 2.600 mm.

3. Nevertheless, the vehicle equipped with such aerodynamic devices has to comply with additional requirements based on UN regulations. In this case UN Regulation No. 58 describes geometric requirements to install the Rear Underrun Protection Device based on the rearmost vehicle body position. In the current series of amendments of UN Regulation

No. 58 the aerodynamic devices are not defined and would have an influence on the position of the Rear Underrun Protection Device.

4. This amendment for UN Regulation No. 58 is proposed to clarify the installation of Rear Underrun Protection Devices with regard to the installation of aerodynamic devices.

5. Paragraph 3.1.5. introduces a definition for “Aerodynamic devices” that is based on a common understanding of the purpose of such devices.

6. The paragraphs 16.4. and 25.3. describe the geometric requirements to install a Rear Underrun Protection Device (RUPD) including some special provisions and exemptions for certain components up to 50 mm length. Based on this principle an amendment is proposed to exempt aerodynamic devices from the determination of the geometric positioning of the RUPD. But this exemption implies some new requirements for the aerodynamic device itself. These new requirements are defined in a new Annex 8.

7. The provisions defined in Annex 8 are based on the assumption that an aerodynamic device fitted at the rear of the vehicle should not harm occupants in other vehicles during a rear-end collision. The main idea is to require a kind of deformation or retraction of the aerodynamic device during an impact that does not compromise the functionality of the RUPD. It is proposed to use a similar test procedure/test equipment as describes in Annex 5 of the 03 series of UN Regulation No. 58. The proposed forces and the required deformation level guarantee that the aerodynamic device would not endanger occupants by intruding into the vehicle occupant’s compartment. The proposed test is required for all parts of the aerodynamic device up to a height of 2.0 m above the ground. Notwithstanding these provisions, manufacturers are free to design an aerodynamic device with a material with a maximum hardness of 60 Shore A. This relates to the hardness of other elastomers and provide a sufficient safety level during a rear-end collision. The Shore durometer is a device for measuring the hardness of a material, typically of polymers, elastomers, and rubbers. Higher numbers in its scale indicate a greater resistance to indentation, and thus harder materials, lower less and softer.

<i>Durometers of various common materials</i>		
<i>Material</i>	<i>Durometer</i>	<i>Scale</i>
Bicycle gel seat	15–30	OO
Chewing gum	20	OO
Sorbothane	30–70	OO
Rubber band	25	A
Door seal	55	A
Automotive tire tread	70	A
Soft wheels of roller skates and skateboard	78	A
Hydraulic O-ring	70-90	A
Hard wheels of roller skates and skateboard	98	A
Ebonite rubber	100	A

(Source: [https://en.wikipedia.org/wiki/Shore\\_durometer](https://en.wikipedia.org/wiki/Shore_durometer))

8. The provisions in paragraph 6.1 of Annex 8 are defined to allow a sufficient deformation or folding functionality under the influence of force. Based on the geometry of the trailer/truck rear end and the geometry of different cars (see below) it would be imminent to define a level of residual space for deformed aerodynamic devices that guarantees a certain safety level for occupants in rear end collisions. The proposed values relate to discussions for the revision of the 96/53 (EC) to allow “Rear Flaps” on heavy duty vehicles. There was mentioned a request by railway operators that for the transport of trailers on the wagon (intermodal traffic) the aerodynamic devices shall have maximum 200 mm in longitudinal direction of the vehicle in folded position. Therefore article 8b, paragraph 3c of (EC) 2015/719 requests: “The aerodynamic devices referred to in paragraph 1 shall fulfil the following operational conditions: their use shall be compatible with intermodal transport



operations and, in particular, when retracted/folded, they shall not exceed the maximum authorised length by more than 20 cm.”

9. The provisions in paragraph 5.1.2. of Annex 8 are defined to allow on the one hand a sufficient stability of aerodynamic devices (e.g. resistance against aerodynamic effects during driving and handling in standstill) and on the other hand to guarantee a level of forces that is applicable to deform/unfold/retract the aerodynamic device. The force of 4.000 N base on the assumption that the passenger car in a rear end collision is in contact with the rear underrun protection device (RUPD) before parts of the aerodynamic devices are partly in contact with other parts of the vehicle body over impact time (see dimensions length of vehicle from front end to centre of front wheel).

10. In parallel it is proposed in the draft amendment of European legislation for “Masses and Dimensions” that aerodynamic devices have to withstand forces of 2.000 N in all directions. Similar provisions were requested by Railway operators and the European Union Agency for Railways in the public consultations of the European Commission. This leads to the complex situation that aerodynamic devices have to withstand external forces up to 2.000 N (required for safe operations during the transport on railways) and have to deform in case of rear-end collisions. In the context of an amendment of UN Regulation No. 58 the current proposal focus on the assessment of the safety level with regard to the functionality of the Rear Underrun Protection Device and excludes any provisions for safe operations at railway transport modes.

Examples: Dimensions Truck/Trailer vs. Cars

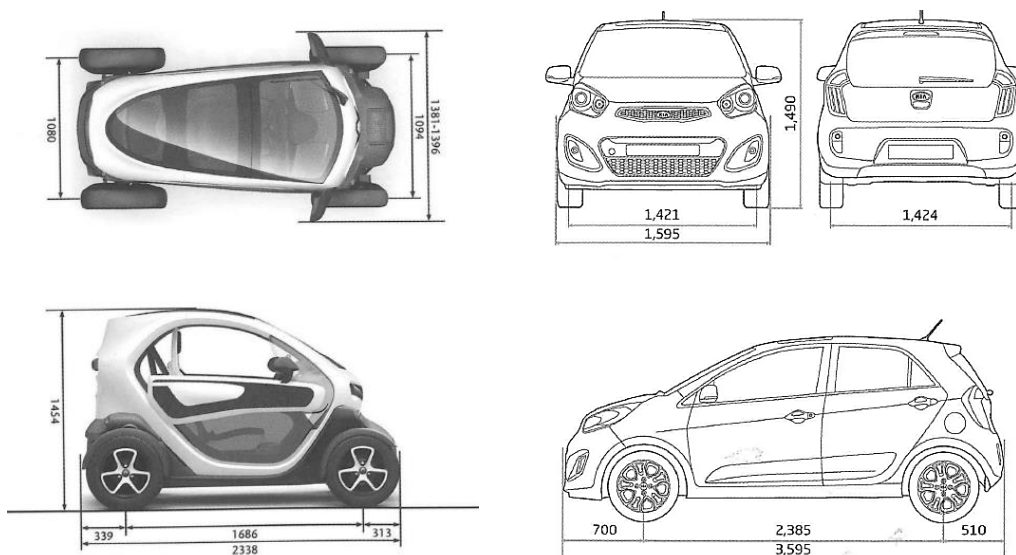

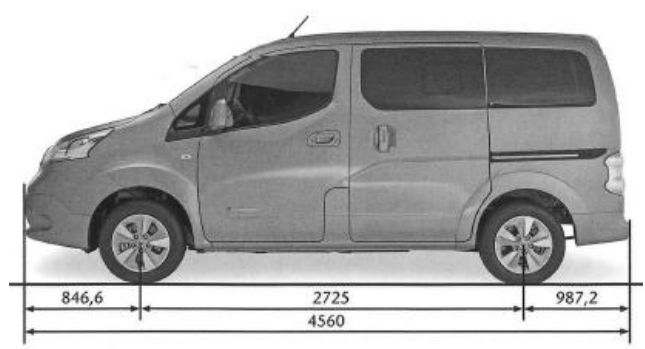
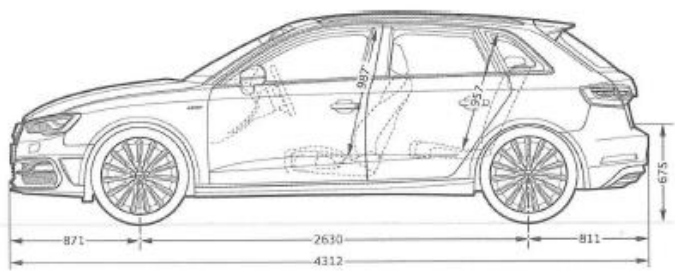
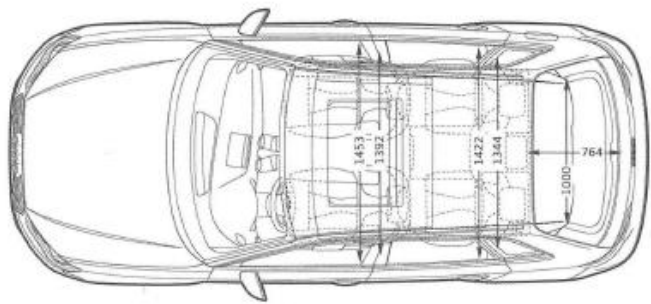
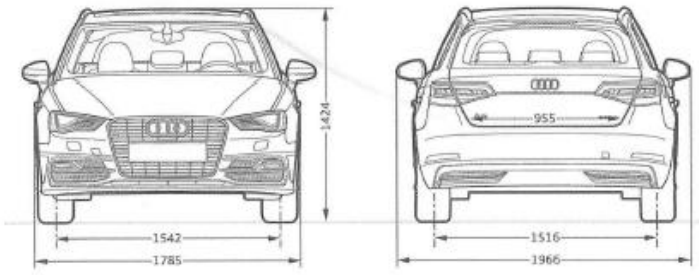

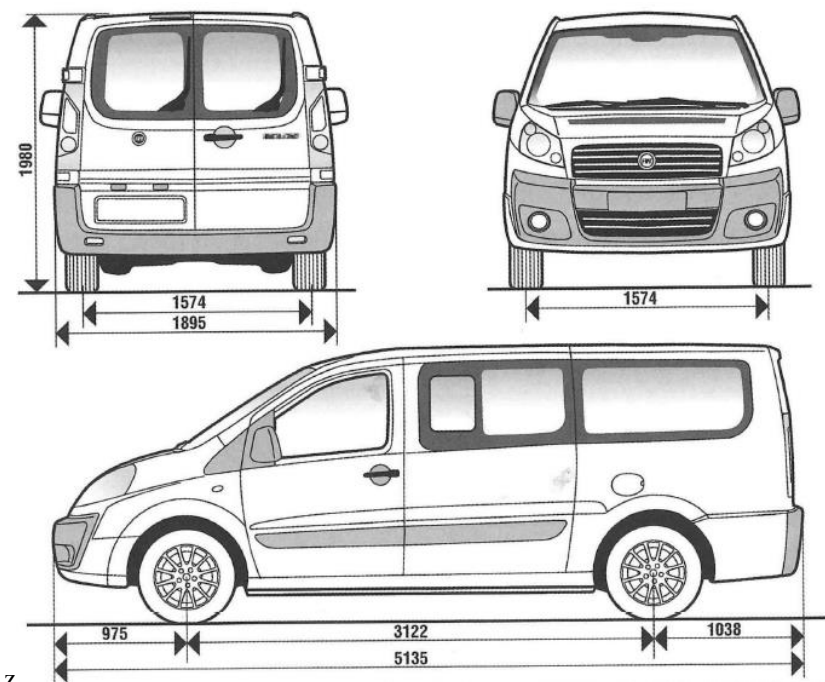
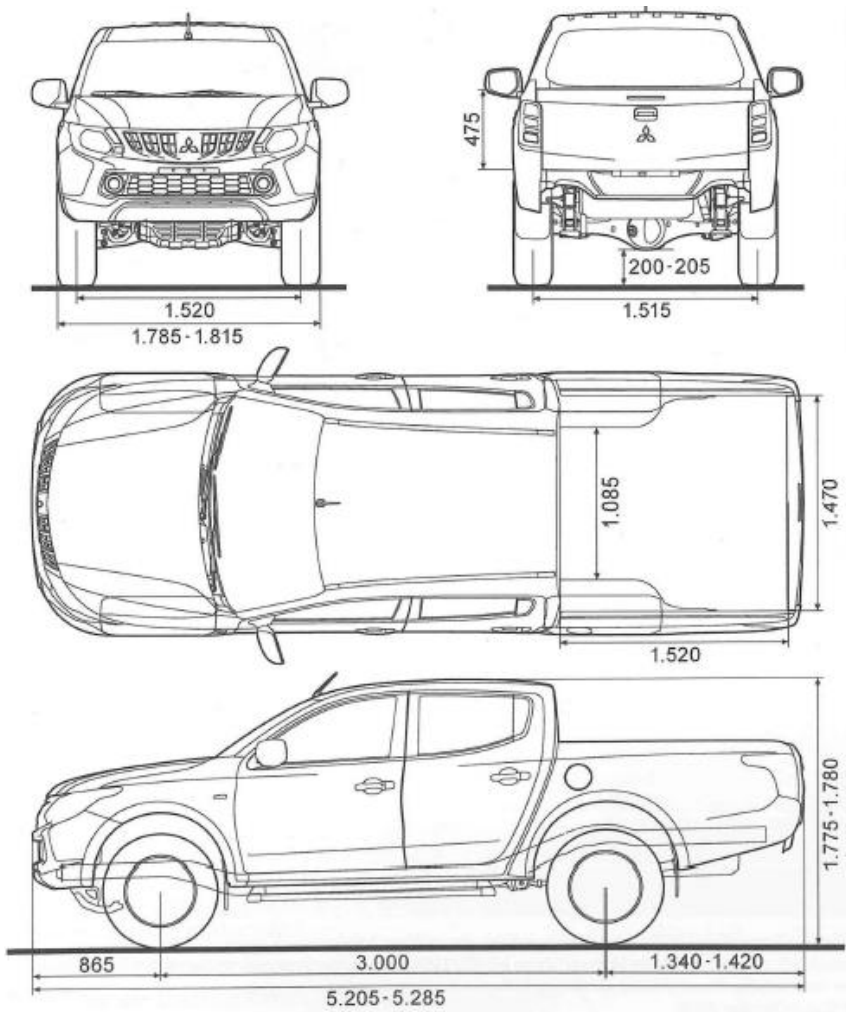

Z

