

Global technical regulation on tyres

Contents

	Page
Executive Summary.....	3
I. Statement of technical rationale and justification	4
A. Introduction and procedural background	4
B. Background of tyre regulations.....	5
C. Procedural background and development of the global technical regulation.....	5
D. Technical and economic feasibility	11
E. Anticipated benefits	11
F. Potential cost effectiveness	11
G. Specific statement of technical rationale and justification for Amendment 1 to UN GTR No. 16.....	11
H. Specific statement of technical rationale and Justification for Amendment 2 to UN GTR No. 16.....	13
II. Text of the global technical regulation	21
1. Scope	21
2. Definitions	21
3. Requirements	29
3.1. Plant codes.....	29
3.2. Marking	30
3.3. Other sidewall markings	30
3.4. Tread wear indicators.....	33
3.5.1. Dimensions of passenger car tyres.....	33
3.5.2. Dimensions of LT/C tyres.....	36
3.6. High-speed performance test	41
3.6.1. High-speed performance test for passenger car tyres.....	41
3.6.2. High-speed performance test for LT/C tyres	44
3.7. Strength test	47
3.7.1. Strength test for passenger car tyres	47
Table 8 Minimum breaking energy	47
3.7.2. Strength test for LT/C tyres	48
Table 10 Minimum Strength	49
3.8. Bead unseating resistance test.....	50
3.8.1. Bead unseating resistance test for tubeless passenger car tyres	50
3.8.2. Bead unseating resistance test for LT/C tubeless tyres with rim codes of 10 or greater.....	53

3.9.	Endurance test.....	57
3.9.1.	Harmonized endurance and low inflation pressure performance test for passenger car tyres.....	57
3.9.2.	Non-harmonized endurance tests for LT/C tyres	60
3.10.	Flat tyre running mode test	64
3.10.1.	Flat tyre running mode test for passenger car tyres	64
3.11.	Rolling sound emission test	65
3.12.	Adhesion performance on wet surfaces test.....	72
3.13.	Rolling resistance test	97
3.14.	Snow performance test relative to snow tyre for use in severe snow conditions	108
Annex 1	Speed symbol table	120
Annex 2	Load Index (LI) and equivalent maximum load rating table	121
Annex 3	Nominal rim diameter code table.....	122
Annex 4	Tyre size designation examples and description	123
Annex 5	Variation of load capacity with speed	126
Annex 6	Tyre-size designations and dimensions.....	128
Annex 7	Tyre standards organizations	135
Annex 8	Rolling resistance test equipment tolerances	136
Annex 9	Theoretical, measuring, minimum and maximum rim widths and codes	139
Annex 10	Deceleration method: Measurements and data processing for deceleration value applying the differential form $d\omega/dt$	145
Annex 11	Test Equipment Tolerances Specification Guidelines	148

Executive Summary

Initial Establishment of UN GTR No. 16

UN Global Technical Regulation (UN GTR) No. 16 for Tyres applies to new radial pneumatic tyres typically for Category 1 and 2 vehicles up to and including 4,536 kg (10,000 pounds). At an early stage it was decided to develop UN GTR No. 16 in two stages, initially for passenger tyres and at a later stage for light truck (commercial) (LT/C) tyres.¹

In developing UN GTR No. 16, several different national regulations were reviewed. For passenger tyres, some of the requirements considered for UN GTR No. 16 existed in only a single national regulation and therefore were adopted without the need for harmonization. These requirements are the endurance test, the low-pressure endurance test, the bead unseating resistance test, the strength test, the rolling sound emission test, the wet grip test and the run flat test. Other requirements required harmonizing differing national regulations, including markings and tread wear indicators, the high-speed performance test and the physical dimension test. For passenger tyres, these requirements were arranged in a “general module” plus two options, which have since been eliminated.²

While an agreement had been reached to harmonize passenger tyre recommendations only in the initial establishment of UN GTR No. 16, several unharmonized requirements for LT/C tyres taken from UN Regulation Nos. 54 and 117 and Federal Motor Vehicle Safety Standard (FMVSS) 139 were included for reference. These requirements were: markings and tread wear indicators (FMVSS 139), physical dimensions test (both), high-speed performance test (both), endurance test (both³), low-pressure endurance test (FMVSS 139), strength test (FMVSS 139), bead unseating resistance test (FMVSS 139), and rolling sound emissions (UN Regulation No. 117).

For a complete discussion of the establishment of UN GTR No. 16 see [paragraphs 1-36] of the Statement of Technical Rationale and Justification.

Amendment 1

Parallel with the development of UN GTR No. 16, UN Regulation No. 117 was amended several times. As it was not feasible to consider these amendments during the development of UN GTR No. 16, it was decided to consider them as a Phase 1b prior to beginning work to harmonize the requirements for LT/C tyres. Amendment 1 amended the wet grip test in UN GTR No. 16 to the most recent version from UN Regulation No. 117. Amendment 1 also amended UN GTR No. 16 to add two new requirements taken from UN Regulation No. 117 – the rolling resistance test and the test for classification of a snow tyre for use in severe snow conditions.

For a complete discussion of Amendment 1 to UN GTR No. 16 see paragraphs 4bis, 4ter, 22bis, 28bis (now 28quater), 28ter (now 28quinquies), and 37-48 of the Statement of Technical Rationale and Justification.

Amendment 2

Amendment 2 to UN GTR No. 16 addresses the harmonization of the previously non-harmonized tests applicable to for light truck / commercial (LT/C) tyres, specifically Physical Dimensions Test and High-speed performance test. The Amendment 2 to UN GTR No. 16 will also cover the most recent updates of UN Regulation Nos. 30 and 54 as well as FMVSS 139 of the United States.

¹ See section 2 of UN GTR No. 16 for definitions of these tyre types.

² Option 1 consisting of the strength test and the bead unseating resistance test. Option 2 consisting of the rolling sound emission test.

³ UN Regulation No. 54 “endurance” test applies only to tyres with P speed symbol and below  150 km/h). For tyres with Q speed symbol and above, UN Regulation No. 54 requirement is a high-speed type test.

For a complete discussion of Amendment 2 to UN GTR No. 16 see relevant sections of the Statement of Technical Rationale and Justification.

I. Statement of technical rationale and justification

A. Introduction and procedural background

1. The objective of UN GTR No. 16 is to establish provisions for new radial pneumatic tyres typically equipping passenger cars and light truck (commercial) vehicles up to and including 4,536 kg (10,000 pounds) under the 1998 Agreement. The official bases of this harmonized set of requirements are UN Regulation Nos. 30, 54 and 117 annexed to the 1958 Agreement, as well as the Federal Motor Vehicle Safety Standard (FMVSS) 139 requirements established in the United States of America under the direction of the National Highway Traffic Safety Administration (NHTSA). Regulations from GCC Standardization Organization (GSO), India and China, although not officially registered in the compendium of regulations for UN GTR No. 16, were also analysed and requirements from them were considered in UN GTR No. 16 insofar as they were not already covered by one of the regulations from UNECE and United States of America. In addition, parts of FMVSS 109 and 119 were copied directly into UN GTR No. 16, since they are applicable to certain tyres for light commercial vehicles (LT or C tyres).

2. Many countries throughout the world have already introduced regulations concerning pneumatic tyres. Many of the existing regulations are based on the four primary ones mentioned above. However, many differences in test conditions and regulatory marking requirements require tyre manufacturers to produce almost identical products but with market specific variations to meet local market requirements – including slight variations on sidewall marking provisions.

2 bis. Consistent with section 7 of the 1998 Agreement Concerning the Establishing of Global Technical Regulations for Wheeled Vehicles, Equipment and Parts which can be Fitted and/or be Used on Wheeled Vehicles, a Contracting Party may decide whether to transpose any individual provision in UN GTR No. 16 into its national regulations at its discretion.

3. The first phase of UN GTR No. 16 harmonized the requirements for passenger car tyres, while Amendment 1 updated the passenger car requirements to include recent amendments to UN and U.S. regulations.

3bis. Amendment 2 to UN GTR No. 16 addressed the technical specification for the harmonization of tyres with the designation of LT or C. Amendment 2 harmonized several provisions for LT/C tyres, including physical dimensions test and the high-speed performance test. See the discussion in paragraphs 49 – 93 for further details.

4. Additional technical evaluation is necessary to assess whether consideration should be given for certain tyre types typical in the North American market in relation to the specifications in paragraph 3.12. (referring to the test for adhesion performance on wet surfaces). Government and industry in the United States of America and Canada are coordinating to conduct this evaluation.

4 bis. For the purposes of future harmonization, it is noted that amendments are anticipated in the areas of the strength test for passenger car tyres and the tubeless tyre bead unseating resistance test for passenger car tyres. For both tests, work is underway

in the United States to consider modifications to the test conditions, performance requirements or both.

4 ter. Following additional technical evaluation of the adhesion performance on wet surfaces, a future additional category of use might be necessary for certain tyre types typical in the North American market.

B. Background of tyre regulations

5. Radial pneumatic tyres for passenger cars and light vehicles are increasingly becoming worldwide products, expected to be used anywhere in the world when mounted as original equipment on new vehicles which are themselves marketed on a global basis. This globalization creates significant opportunities for manufacturers to deliver better and more cost-efficient products but also requires harmonization of the technical provisions at a global level to avoid increasing manufacturing costs.

6. Although testing requirements for different regulations used around the world are often substantially similar, slight variations in test procedures oblige tyre manufacturers to test the same object for the same performance characteristic under slightly different conditions, without any significant improvement in the final product.

7. Marking requirements are also variable around the world, and the same tyre may need several different approval marks to be marketed in a truly worldwide fashion. Any harmonization of such markings should continue to be a priority, as it would clarify the administrative identity of the tyre and facilitate the management of production moulds.

C. Procedural background and development of the global technical regulation

8. UN GTR No. 16 was developed by the GRRF informal working group on the Tyre UN GTR.

9. The work on UN GTR No. 16 began informally in December of 2004 with a meeting in Paris. As required by the 1998 Agreement, a formal proposal for the establishment of UN GTR No. 16 was proposed to the Executive Committee of the 1998 Agreement (AC.3) by the technical sponsor, France. At the 140th session of the World Forum for Harmonization of Vehicle Regulations (WP.29) on 14 November 2006, the French proposal was approved as UN GTR No. 16 project by AC.3 (ECE/TRANS/WP.29/2006/139). The adopted proposal was published as ECE/TRANS/WP.29/AC.3/15.

10. Subsequent to that approval, the informal working group on UN GTR No. 16 met on numerous occasions. In addition to three unofficial meetings held between December 2004 and November 2006, another ten meetings were scheduled in conjunction with GRRF sessions and a further two interim meetings were held in Brussels in July 2007 and July 2009.

11. In 2009, at the request of the informal working group, AC.3 approved the development of UN GTR No. 16 in two phases: the initial phase being dedicated to harmonizing requirements for passenger car tyres only, and requirements for light truck tyres, which carry a C or LT designation, to be harmonized as a second phase. In the interim, the existing requirements for C or LT tyres (albeit non-harmonized) are included in the first stage of UN GTR No. 16 for completeness. The current document reflects that decision and contains only harmonized requirements for passenger car tyres, with the LT/C requirements remaining to be harmonized.

12. Tests or requirements for radial passenger car tyres required extensive harmonization during the course of the informal working group's mandate. These harmonized tests or requirements are:

- (a) High-speed performance test;
- (b) Physical dimensions test;
- (c) Required markings.

13. Several other test requirements for radial passenger car tyres existed only in one of the existing regulations and needed no harmonization. These tests were simply included as direct copies in UN GTR No. 16. In particular, no harmonization was required for:

- (a) Endurance test;
- (b) Low-pressure endurance test;
- (c) Bead unseating resistance test;
- (d) Strength test;
- (e) Rolling sound emission test;
- (f) Wet grip test;
- (g) Run flat test.

14. Harmonizing the high-speed performance test for passenger car tyres posed a significant challenge in that the two existing tests were quite different from each other and based on different principles. One was designed to ensure that a tyre would perform adequately at speeds well above a national speed limit, but the test requirements were not related to any speed symbol indicated on the tyre itself. The other required that a tyre pass a test at its highest rated speed.

15. Taking into account the long experience of FMVSS standards in the United States of America and in countries applying UN Regulation No. 30, and the huge volume of test results corresponding to these two testing procedures, it was decided to base harmonization on a combination of the two existing test procedures rather than develop a wholly new harmonized test procedure. The harmonization work was based on a determination of which test was more onerous for tyres of different speed symbols, using the best test procedure.

16. At the meeting of the ad hoc working group in September 2006, three different scenarios for the high-speed performance test harmonization were discussed. One of the options considered was to use the FMVSS 139 high-speed performance test for tyres with a speed rating equivalent to the symbol of "S" and below (less than or equal to 180 km/h), and the UN Regulation No. 30 test for speed symbols above "S" (greater than 180 km/h). At that meeting, there was a general consensus by the Contracting Parties that this proposal could be considered as a starting point, but it would require significant further work in order to demonstrate the validity of the proposal.

17. The tyre industry presented a theoretical method to determine, for each speed symbol, the test which is the most severe and to validate that the equivalence point (the speed symbol for which both tests are equally severe) between the two tests is reached at a specific speed symbol. Over the following year the tyre industry gathered data to demonstrate this concept. Six tyre manufacturers supplied data, and in total, 704 tyres were tested using both tests. All the tyres were tested above and beyond the normal high-speed performance test requirements, and the number of steps that each tyre was able to withstand above the regulatory limit, were counted. The ratio of the number of

Steps above the Limit (SAL) for the FMVSS 139 test, divided by the number of steps above the limit for UN Regulation No. 30 test was used to evaluate the data. Based on this extensive set of data, it was determined that the FMVSS 139 high-speed performance test was more severe for tyres with speed symbol of S and below (less than or equal to 180 km/h). The UN Regulation No. 30 high-speed performance test was more severe for tyres with speed symbols of T (190 km/h) and above.

18. To validate this concept further, work was undertaken on a smaller sample of tyres to determine the temperature increase during the different tests. In all cases, it was demonstrated that for T rated tyres and above, greater energy input was required (as determined by the increase in the contained air temperature) during the UN Regulation No. 30 test than from the FMVSS 139 test. This data was also independently confirmed by one of the Contracting Parties. Since the increase in temperature of a tyre should be directly related to the amount of energy supplied during the test, a higher internal tyre temperature at the end of a test indicates a higher degree of severity. At the meeting in September 2008, it was agreed to use UN Regulation No. 30 test for tyres with speed symbols of T (190 km/h) and above, and to use the FMVSS 139 high-speed performance test for all lower speed symbols (180 km/h and below).

19. The physical dimensions test was less difficult to harmonize from a technical point of view, because of the elementary simplicity of determining the outside diameter and width of a tyre in its inflated state to ensure interchangeability between tyres marked with the same size designation. A small but not insignificant gain has been achieved by harmonizing the measuring of the tyre's width at four points around the circumference.

20. After the inventory of different tests for passenger car tyres existing in the world had been made, it appeared that some of these tests might be harmonized on a worldwide level, while some of them appeared to have a more regional application. In order to take this situation into account, the different tests were organized into three modules: a mandatory minimum requirement and two permissive requirements.

21. This modular structure was described in document ECE/TRANS/WP.29/AC.3/15 that was adopted by AC.3 as the formal request of authorisation to develop UN GTR No. 16.

22. The informal working group developing UN GTR No. 16 pursued the modular approach. As the group continued to develop the modular approach a wider appreciation among Contracting Parties of the application of modules emerged. This prompted proposals for a less prescriptive approach to some of the individual elements included in the mandatory module. The informal group considered alternatives to deliver the requirements of Contracting Parties while retaining the original modular approach but could not find a sufficiently robust solution. As a result, the group proposed a revised structure centred upon a "General Module" plus two options (Options 1 and 2). These are described in the table.

<i>Passenger car tyres</i>		
	<i>Test name</i>	<i>Paragraph(s)</i>
General module	Marking and tread wear indicators	3.2., 3.3. and 3.4.
	Physical dimensions test	3.5.1
	High-speed test	3.11.
	Endurance and low-pressure test	3.9.1

	Wet grip test	3.12.
	Run flat test	3.10.1.
Option 1	Strength test	3.7.1.
	Bead unseating resistance test	3.8.1.
Option 2	Rolling sound emissions	3.11.

22 bis. However, since UN GTR No. 16 contains only technical prescriptions and no legal aspects concerning implementation of UN GTR No. 16 in national/regional legislation of the Contracting Parties to the 1998 Agreement, irrespective of the above described module concept, only a Contracting Party decides how to transpose UN GTR No. 16 provisions into its national/regional legislation. In order to facilitate the transposition process, a stepwise approach may be recommended, where the first stage is to select just those provisions and test methods of UN GTR No. 16 that meet the most immediate regulatory needs of a Contracting Party. For example, when adopting rolling resistance provisions together with wet grip provisions, attention should be given to assure that one performance is not optimized at the expense of another. The second stage would be to consider additional performance requirements, considering the possible trade-offs with the other desired tyre performances. Meanwhile, such a Contracting Party will allow access to its internal market for tyres complying with the provisions of UN GTR No. 16 that the Contracting Party has not adopted if such tyres meet the national/regional legal requirements of that Contracting Party.

23. The initial version of UN GTR No. 16 only provided harmonized requirements for passenger car tyres. In Amendment 2 to UN GTR No. 16, harmonized requirements were added for LT/C tyres. The module concept does not apply to LT/C tyres, and the following table describes the harmonized tests applicable to these tyres following Amendment 2.

<i>LT/C tyres</i>	
<i>Test name</i>	<i>Paragraph(s)</i>
Marking and tread wear indicators	3.2., 3.3. and 3.4.
Physical dimensions test	3.5.2.
High-speed test	3.6.2.
Endurance test (not harmonized)	3.9.2.
Wet grip test	3.12.
Run flat test	None
Strength test	3.7.2.
Bead unseating resistance test	3.8.2.
Rolling sound emissions	3.11.
Tyre rolling resistance	3.13.

24. In the case of required markings, it was possible to eliminate some that had become unnecessary over the years, such as the words Radial and Tubeless. Indeed over 90 per cent of passenger car tyres and LT/C tyres sold worldwide are of radial, tubeless construction and so continuing to mark tyres is unnecessary. In addition, a change was made in the way the Tyre Identification Number (TIN) will be used in combination with other markings.

25. The TIN format is based on NHTSA's 2015 change from 2-digit plant codes to 3 digits. A symbol, the number "1" for example, will be reserved to precede most existing 2-digit codes, and be used exclusively for existing plant codes. The "1" is used as the prefix for existing 2-digit codes, and not be used as the leading digit for any new 3-digit codes. NHTSA will continue to assign global plant codes and the necessary information to obtain such a code is contained within UN GTR No. 16.

26. The aim of UN GTR No. 16 is to introduce the universal worldwide harmonized requirements to tyres included into the scope of UN GTR No. 16. In accordance with the provisions of the 1998 Agreement, once UN GTR No. 16 is adopted, those Contracting Parties voting in favour of its adoption will start the process of transposing those requirements into their national legislation. In a case when a test procedure includes several options, a Contracting Party may select the option(s) at its discretion.

26 bis. In the interest of moving rapidly towards creating a "global tyre" approach, the Contracting Parties should transpose UN GTR No. 16 requirements in a flexible way to permit tyres complying with the full requirements access to as many markets as possible.

27. Consideration was given to harmonize the approval markings (both type approval and self-certification markings) and discussions on this issue were elevated to WP.29 and AC.3 meetings. It was concluded as not possible currently to adopt a harmonized approval marking since the compliance assessment procedures are not yet harmonized worldwide. Consequently, UN GTR No. 16 contains no administrative provisions on approval markings. In the absence of a harmonized marking, the Contracting Parties retain the option to assign markings to tyres, especially markings for a "global tyre", and these can be introduced within their national / regional compliance assessment systems.

28. It is anticipated that the Contracting Parties will incorporate the provisions of UN GTR No. 16 into regulations within their legal framework. This may include applying suitable tyre marking and so help provide for market recognition between the Contracting Parties of tyres complying with the provisions of UN GTR No. 16. Such an approach might encourage wider recognition of harmonized markings and thus further the move towards a single global marking where tyres meet the full requirements established by UN GTR No. 16.

28 bis. It is recognised that different regulatory provisions inconsistent with UN GTR No. 16 may be necessary in a specific country for regional tyres to accommodate local needs for specific tyre types. Consequently, a Contracting Party may choose to retain additional tyre regulatory provisions for regional tyres inconsistent with UN GTR No. 16 within its legal framework.

28 ter. When adopting the provisions of UN GTR No. 16, a transition period of up to ten years is recommended to minimize costs associated with regulatory changes that require different tyre markings. The typical useful life of a tyre mould is between five and ten years, depending on several factors, including but not limited to tyre type and size, tyre line and mould usage. According to NHTSA, all tyre moulds in use at a point in time would be retired within 13 years, based on a linear regression model.

28 quater. In parallel to development of UN GTR No. 16, UN Regulation No. 117, which is a base for UN GTR No. 16, had been amended several times by detailing and extending the provisions to tyre wet grip performance, adding the provisions for rolling resistance and for classification as snow tyre for use in severe snow conditions for all tyre classes included in its scope. As harmonization of the newly introduced provisions of UN Regulation No. 117 was not feasible in a reasonable time frame, the decision for UN GTR No. 16 was not to consider those provisions for inclusion in the text of UN GTR No. 16 at that time. Those new provisions represent the state-of-the-art level and are important for assessment of performance of tyres on the markets worldwide. Therefore, at so-called "Phase 1b" the relevant provisions aligned with those of UN Regulation No. 117 are introduced by the Amendment No. 1 to UN GTR No. 16.

28 quinques. The Amendment No. 1 to UN GTR No. 16 incorporates:

- (a) Amendment of Part I by adding new paragraphs 4bis, 22bis, 28bis (now 28quater) and 28ter (now 28quinques);
- (b) Amendment of Part II:
 - (i) Addition of new definitions;
 - (ii) Modification of test for adhesion performance on wet surfaces;
 - (iii) Addition of new requirements to rolling resistance;
 - (iv) Addition of new requirements for qualification of a tyre to be designated for use in severe snow conditions;
- (c) Addition of new Annexes containing the details of the newly added test methods.

28 sexies. The Amendment 2 to UN GTR No. 16 incorporates:

- a. Amendment of Part I by adding new paragraphs 49 – 93;
- b. Amendment of Part II:
 - i. Alignment of scope and clarifications
 - ii. Alignment of the provisions with the most recent developments in UN Regulations
 - (a) Addition of new or updated definitions
 - (b) Alignment of the provisions for tyre marking
 - (c) Alignment of the provisions for tyre physical dimensions
 - iii. Elimination of inconsistencies in the text
 - (a) Reference Test Inflation Pressure
 - (b) Measuring rim
 - iv. Updates of Annexes 3, 5, 6, 9 and 11
 - v. New Harmonized Provisions
 - (a) Reference test inflation pressure
 - (b) Tread wear indicators
 - (c) Physical dimensions
 - (d) High-speed test

- vi. Amendments reflecting Chinese and Indian proposals
- vii. Others
- viii. Future Work

D. Technical and economic feasibility

29. UN GTR No. 16 has been developed by drawing on the experience of many stakeholders, including regulatory authorities, type approval authorities, tyre and vehicle manufacturers and technical consultants. UN GTR No. 16 has been built upon the experience of many organizations and individuals with expertise in the area of tyres for passenger cars and light trucks or light commercial vehicles.

30. UN GTR No. 16 has been designed to update and improve upon existing regulations, and the requirements are based on existing concepts in different Contracting Parties' present regulations.

31. Since UN GTR No. 16 is based on existing requirements and some harmonized tests, no economic or technical feasibility study was deemed necessary. When transposing this UN GTR into national legislation, Contracting Parties are invited to consider the economic feasibility of UN GTR in the context of their country.

E. Anticipated benefits

32. The principal economic benefit of UN GTR No. 16 will be a reduction in the variety of tests for the same or substantially similar requirements.

33. Depending on how different Contracting Parties implement UN GTR No. 16, there may be benefits due to the way the approval markings are treated. Tyre mould design and fabrication might be rationalized, with associated reductions in production costs.

34. Safety benefits resulting from the transposition of UN GTR No. 16 in the national legislations depend on the previous level of the national regulations.

F. Potential cost effectiveness

35. It is not possible to assess, at this moment, the total costs linked to UN GTR No. 16. On one hand, there are more tests in UN GTR No. 16 than in the existing national or international regulations. On the other hand, the harmonization of the regulation will reduce the global cost of type approval in the variety of countries which will apply UN GTR No. 16 through that administration procedure.

36. Safety benefits are anticipated, but it is not yet possible to assess them in terms of reduction of number of accidents and victims.

G. Specific statement of technical rationale and justification for Amendment 1 to UN GTR No. 16

I. Objective

37. The objective of Amendment 1 is to develop, in the framework of the 1998 Agreement, an amendment to UN GTR No. 16 on tyres aimed at adaptation of UN GTR

No. 16 to the technical progress by including the newly developed provisions to wet grip performance, rolling resistance and qualification for use at severe snow conditions both for passenger car (PC) and light truck / commercial (LT/C) tyres, recently adopted within UN Regulation No. 117. The approved changes in the relevant Federal Motor Vehicle Safety Standards (FMVSS) and UN Regulation Nos. 30 and 54 also had been included.

II. Introduction and procedural background

38. UN GTR No. 16 was established in the Global Registry on 13 November 2014. The informal working group on UN GTR No. 16 was challenged by reaching harmonization of technical provisions making those acceptable both for type approval and self-certification compliance assessment systems.

39. Meanwhile, in parallel to development of UN GTR No. 16, UN Regulation No. 117, which is one of the bases for UN GTR No. 16, was amended several times by inclusion of the provisions to tyre wet grip performance, rolling resistance and qualification for use at severe snow conditions for all tyre classes included in its scope. Other base UN Regulation Nos. 30 and 54 were also subjects to certain amendments, and the relevant provisions of UN GTR No. 16 needed to be aligned.

40. As harmonization of the newly introduced provisions of UN Regulation No. 117 was not feasible in a reasonable time frame, the decision for draft UN GTR No. 16 was not to consider those provisions for inclusion in the text of UN GTR No. 16 at the time of its development.

41. As the aforesaid new provisions of UN Regulation No. 117, as well as those of UN Regulation Nos. 30 and 54 represent the state-of-the art level and are important for assessment of performance of tyres on the markets worldwide, at the 79th GRRF session the decision was made to prepare a draft amendment keeping UN GTR No. 16 in line with the latest regulatory developments (ECE/TRANS/WP.29/GRRF/79, para. 27).

42. The European Tyre and Rim Technical Organisation (ETRTO) agreed to prepare a draft Amendment No. 1 to UN GTR No. 16 considered as Phase 1b of the development of UN GTR No. 16. The Government of the Russian Federation assumed the duties of the technical sponsor for that development.

III. Justification of changes

(a) Amendment of Part I

43. This Amendment 1 incorporates five new paragraphs in Part I of UN GTR No. 16: 4bis, 4ter, 22bis, 28bis (now 28quater) and 28ter (now 28quinquies).

44. Paragraphs 4bis and 4ter are added for information for further anticipated amendments in UN GTR No. 16 to be followed the results of current rulemaking activities in the United States in the field of the strength test for passenger car tyres and the tubeless tyre bead unseating resistance test for passenger car tyres. Following additional technical evaluation of the adhesion performance on wet surfaces, a future additional category of use might be necessary for certain tyre types typical in the North American market.

45. Paragraph 22bis provides for additional clarification that no legal aspects concerning implementation of UN GTR No. 16 in national/regional legislation of the Contracting Parties to the 1998 Agreement is provided within the text of UN GTR No. 16, therefore the way of transposition of UN GTR No. 16 provisions into its

national/regional legislation is at the discretion of the Contracting Parties. In this regard, paragraph 22bis contains recommendations on anticipated practice of transposition of the provisions of UN GTR No. 16 into national/regional legislation of the Contracting Parties providing for facilitation of the transposition process. The recommendations of paragraph 22bis are partly based on the developments of the WP.29 Informal Group dealing with the development of the procedure of International Whole Vehicle Type Approval (IWVTA).

46. Paragraph 26 has been amended to clarify that when a test procedure includes several options, a Contracting Party may select the option(s) at its discretion, understanding that unique tolerances could preclude mutual recognition.

47. Paragraphs 28bis (now 28quater) and 28ter (now 28quinquies) briefly explain the objective and the content of Amendment 1 to UN GTR No. 16. These two paragraphs are added for clarity and refreshment of history, when this Amendment 1 will be incorporated into the main text of UN GTR No. 16.

(b) *Amendment of Part II*

48. See the Technical Report on the development of Amendment 1, para. 16 (i)

H. Specific statement of technical rationale and Justification for Amendment 2 to UN GTR No. 16

I. Objective

49. The objective of Amendment 2 is to develop, within the framework of the 1998 Agreement, an amendment to UN GTR No. 16 aimed at further harmonization of its provisions and updating UN GTR No. 16 to reflect recent amendments to UN Regulations. Amendment 2 also adds new harmonized provisions for physical dimensions and high-speed performance test for LT/C tyres.

II. Introduction and procedural background

50. In the initial version of UN GTR No. 16, the harmonized requirements apply only to passenger car tyres although, as described in paragraph 23 of this Part, some non-harmonized tests applicable to LT/C tyres were included in the original UN GTR No. 16. Amendment 1 was subsequently established in the UN Global Registry on 17 November 2016, including the newly developed provisions for wet grip performance, rolling resistance and qualification for use in severe snow conditions both for passenger car and LT/C tyres.

51. GRRF at its 82nd session in September 2016 endorsed the establishment (reinstating) of the Informal Working Group for the Phase 2 of development of UN GTR No. 16 (Tyres) dealing with development of Amendment 2 to UN GTR No. 16 to harmonize provisions for LT/C tyres, including marking, high-speed performance test and measuring tyre dimensions. In addition, the informal working group considered possible further developments of UN GTR No. 16, including the feasibility of harmonizing of endurance test for LT/C tyres and the introduction of a global tyre marking. The expert from the Russian Federation volunteered to lead the development of this amendment and requested the authorization to develop Amendment 2 to UN GTR No. 16 from the Executive Committee of the 1998 Agreement (AC.3) (ECE/TRANS/WP.29/GRRF/82, para. 28).

52. The government of the Russian Federation assumed the duties of the technical sponsor for that development. The European Tyre and Rim Technical Organisation

(ETRTO) in cooperation with other tyre manufacturers' associations agreed to assume the role of Secretary in the development of the draft Amendment 2 to UN GTR No. 16.

53. The AC.3 at its 48th session in March 2017 adopted ECE/TRANS/WP.29/2017/52 tabled by the Russian Federation to request authorization to start work on developing the Amendment 2 to UN GTR No. 16 (ECE/TRANS/WP.29/1129, para. 153). After the adoption, this document was assigned the reference number ECE/TRANS/WP.29/ AC.3/48.

54. At its 175th session in June 2018, The World Forum for Harmonization of Vehicle Regulations realigned work streams assigned to the various Working Parties. Tyre-related work under both the 1958 Agreement and the 1998 Agreements was removed from the Working Party on Brakes and Running Gear (GRRF) mandate and placed under the Working Party on Noise (GRB) mandate. Consequently, GRB was renamed to the Working Party of Noise and Tyres (GRBP). Beginning with the 68th session of the GRBP, tyre-related regulations, including UN GTR No. 16, were discussed within GRBP. Likewise, the informal working group for UN GTR No. 16 was moved under GRBP.

55. The informal working group held ten meetings between 2017 and 2019 to consider provisions for Amendment 2. The informal working group considered several proposals during the course of these sessions.

56. Amendment 2 to UN GTR No. 16 addresses the harmonization of physical dimensions test and high-speed performance test for LT/C tyres. It also covers the most recent updates of UN Regulation Nos. 30 and 54 as well as FMVSS of the United States. Due to challenges associated with harmonizing the endurance test provisions, the informal working group deferred further work on this topic. No other areas required harmonization, because multiple provisions did not exist for any other tests.

III. Justification of Changes

(a) Amendment to Part I

57. Amendment 2 incorporates 45 new paragraphs in Part I of UN GTR No. 16.

(b) Amendment of Part II – Text of the Global Technical Regulation

i. Alignment of scope and clarifications

58. The scope of UN GTR No. 16 was amended to exclude Special Tyres (ST) for trailers in highway service and LT/C tyres with tread-depth of greater than or equal to 14.3 mm (18/32 inch). Previously, these tyre types could be optionally excluded by a Contracting Party.

59. The scope of UN GTR No. 16 was amended to specify the Class C3 tyres to which UN GTR No. 16 does not apply, clarifying that UN GTR No. 16 does not apply to Class C3 tyres “except those with Load Index between 122 and 131 that contain “LT” or “C” in the size designation”.

60. A new section was added to indicate that UN GTR No. 16 provides definitions for different types of tyres.

61. Several subsections were added or modified to provide definitions of different types of tyres, including “high flotation”, “light truck or commercial tyre”; was added consistent with UN Regulation No. 54. Additionally, editorial changes to the definition of “passenger car tyre” were made to add the word “car”.

62. Definitions of “load index”, “load capacity”, “maximum load rating”, “reference test inflation pressure”, “standard reference test tyre (SRTT)” were added consistent with the amendments made in UN GTR No. 16 to harmonize concepts of load range and PSI Index by translating load range into inflation pressure ranges and replacing the term “PSI Index” with the term “Reference Test Inflation Pressure.
63. Definitions of “measuring rim width”, “minimum and maximum rim widths”, “nominal section width”, “test rim”, “theoretical rim width” were added consistent with amendments made regarding measuring rim requirements described below.
64. Editorial additions and amendments were made to the definitions to the terms “extra load”, “passenger car tyre”, “tyre”, “spin traction test”, “trade description/commercial name” for clarity. The term “metric sizes” was also added for clarity.
- ii. Alignment of the provisions with the most recent developments in UN Regulations
- a. Addition of new or updated definitions
65. The scope of UN GTR No. 16 was amended to add the word “pneumatic” in alignment with UN Regulation No. 30.
66. Several definitions were amended to reflect amendments to UN Regulation Nos. 30 and 117. The affected definitions included “brand name/trademark”, “carcass”, “pneumatic”, “normal tyre” and “section width (S)”. A definition of “manufacturer” and trade description/commercial name” was also inserted, consistent with UN Regulation No. 30.
- b. Alignment of the provisions for tyre marking
67. Alignment of the provisions for tyre marking of passenger car tyres with the most recent developments in UN Regulation Nos. 30 and 54 (Sections 2, 3.3 and 3.5).
68. The inscription “M+S”, “M.S.”, “M&S”, “M-S”, or “M/S”, have been specified as optional if a tyre is a special use tyre, in line with UN Regulation No. 54.
69. The suffix “LT” after the tyre to rim fitment configuration has been introduced, in line with UN Regulation No. 54.
- c. Alignment of the provisions for tyre physical dimensions
70. The Section width and Outer diameter of the tyre have been aligned with UN Regulation No. 30.
71. The Section width and Outer diameter of the tyre have been aligned with UN Regulation No. 54.
- iii. Elimination of inconsistencies in the text
- a. Reference Test Inflation Pressure
72. As described in paragraph 64 above, FMVSS 139 requirements relative to load range and UN PSI index (3.14 and 3.15). Strength test and bead unseat test provisions were harmonized to translate load range into a corresponding reference test inflation pressure.
73. Amendment 2 provides specific reference test inflation pressures for performing the various prescribed tests. The test prescriptions define a singular test inflation for each reference test inflation pressure range to ensure common test severity. Therefore,

either specifying or marking (branding) a specific load range (or ply rating) on the tyre is no longer needed. Ply rating is used to identify a given tyre with its maximum recommended load when used in a specific type of service. It is an index of tyre strength and does not necessarily represent the number of cord plies in a tyre. Since some Contracting Parties continue to use the term “ply rating,” the table below is provided for reference to assist Contracting Parties in converting from ply rating to load range, which can then be converted to reference test inflation pressure as defined in Section 2.56.

<i>Load Range and Ply Rating Conversions extracted from Tire and Rim Association Yearbook, 2014.</i>	
<i>Load Range</i>	<i>Ply Rating</i>
B	4
C	6
D	8
E	10

74. UN GTR No. 16 was amended to allow for a tyre to be marked with both the inflation pressure corresponding to the maximum load of the tyre and a reference test inflation pressure where the reference test inflation pressure differs from the inflation pressure marked for single application, consistent with U.S. regulations. While most LT/C tyres are marked with a pressure equivalent to the reference test inflation pressure, the FMVSS 139 Section 5.5.6 allows a tyre manufacturer the option to mark a different pressure on the tyre sidewall.

b. Measuring rim

75. Minimum and maximum rim width were added in the tables of Annex 6 to allow for the measurement of tyre dimensions on a certain range of rim widths, aligned with the practice for tyres that are not covered by the annex 6. This addition is necessary because all the rim widths are not always available from the tyre manufacturer or the verification authorities and is consistent with the common practice of allowing a tyre to operate within a range of rim widths.

iv. Updates of Annexes 3, 5, 6, 9 and 11

76. Annex 3 of UN GTR No. 16 was updated consistent with UN Regulation Nos. 30 and 54 and provides rim width codes and corresponding rim widths.

77. Annex 5 of UN GTR No. 16 was updated to align language on variation of load capacity with speed for Passenger car tyres with the provisions in UN Regulation No. 30 and consistent with the high-speed performance test for passenger car tyres where the test conditions reflect the variation described in Annex 5.

78. Annex 6 of UN GTR No. 16 was updated consistent with the most recent developments in UN Regulation No. 54 to reflect dimensions for tyres with “LT” designation that are high flotation tyres. Specifically, minimum and maximum rim width code were added, eight additional sizes were added and note 3 was amended for clarity.

79. Annex 9 was updated ensure consistency within UN GTR No. 16 in terms of minimum, measuring and maximum test rims. The initial and amendment 1 versions of UN GTR No. 16 refer to Annex 9 for the measuring rim of some category of tyres, to

standard organisations in other cases, and to the standard organisations for the minimum and maximum rim.

80. Annex 11 of UN GTR No. 16 was added to provide Contracting Parties with guidance on potential compliance tolerances for various values in the technical prescriptions of UN GTR No. 16. It is at the discretion of a Contracting Party whether and how tolerances are applied in its national regulations when transposing UN GTR No. 16, understanding that unique tolerances could preclude mutual recognition.

v. New harmonized provisions

a. Reference test inflation pressure

81. The concept of reference test inflation pressure was introduced to replace the term “PSI index” used in UN Regulation No. 54, which is a test inflation pressure defined by the tyre manufacturer. The concept of “PSI index” was inconsistent with the provisions from the FMVSS 139, which defines inflation pressure in relation to the tyre load carrying capacity. To harmonize these concepts, reference test inflation pressure was introduced to clearly define inflation pressure in relation to the maximum load rating. All the references to “PSI index” in the text have been changed to “Reference Test Inflation Pressure.”

b. Tread wear indicators

82. Tread wear indicator provisions have been introduced for LT/C tyres, in line with the FMVSS 139 requirements.

c. Physical dimensions

83. Physical dimensions provisions were harmonized by deleting the previous section 3.5.1 and 3.5.2 adding a new section 3.20. Physical dimensions provisions were also harmonized by integrating provisions for measuring and calculating physical dimensions and assuring that all LT/C tyre sizes are addressed by the provisions. Additional provisions were added to address high flotation sizes.

d. High-speed performance test

84. The high-speed performance test for LT/C tyres was harmonized. The harmonized test contains two sets of requirements: the first for LT/C tyres with speed symbols below “Q” and other for LT/C tyres with speed symbols greater than or equal to “Q”. The informal working group concluded that for tyres with speed symbols below “Q” the FMVSS 139 test was the most severe then developed a modified UN Regulation No. 54 high-speed performance test that was equivalent to the FMVSS 139 high-speed performance test in terms of test severity. This modified UN Regulation No. 54 test represents a more efficient test than the FMVSS 139 high-speed performance test because it is of shorter duration, which impacts the capacity of testing facilities and reduces testing costs while representing a test that is comparable in terms of safety. Additionally, eliminating the break-in and cool down cycles further economizes laboratory resources without affecting test results. The results of the tyre industry testing programme were accepted by the informal working group without additional validation by a Contracting Party. For tyres with Speed Symbols “Q” and above the Amendment 2 of UN GTR No. 16 substituted the non-harmonized provisions of UN Regulation No. 54 by the new harmonized provisions of the modified load/speed endurance test method. A provision was also added to recognise a case of a tyre with an alternative service description, specifying that a second tyre of the same type should be tested according to the alternative service description unless a clear engineering

justification is made that a single test represents the worst-case combination of load index and speed category symbol.

vi. Amendments reflecting Indian and Chinese proposals

85. The informal working group considered a proposal by India that would have revised the strength test for passenger car tyres and LT/C tyres to address the situation when a plunger is stopped by the plunger bottoming out against the rim before reaching the specified energy value by stating that the tyre is deemed to have passed the test at that point. India cited several international standards that recognize this situation and allow a tyre to pass the test when it occurs. The provisions in UN GTR No. 16 are based on U.S. regulations that currently are undergoing review. The informal working group developed compromise language in Amendment 2, which provides that “If the tyre fails to break before the plunger is stopped on reaching the rim, and the required minimum breaking energy is not achieved, then record the bottom out and the corresponding energy, the test results are inconclusive and Contracting Parties may provide further guidance to manufacturers. This new language has been included in the strength test for passenger car tyres and the strength test for LT/C tyres”

86. The informal working group evaluated a proposal made by India to include additional minimum breaking energy values in the strength test for small diameter tyres. The informal working group verified that values for small diameter tubeless radial tyres are included in UN GTR No. 16 and added requirements for rim diameter codes 13 and below to the table listing minimum breaking energy values.

87. The informal working group considered whether several regional and national markings should be included in UN GTR No. 16 as proposed by the Peoples’ Republic of China. In general, the informal working group recognized that Contracting Parties have the right to retain optional markings in national regulations under the provisions of the 1998 Agreement. The table below lists each marking considered and the action taken or recommendation of the informal working group:

<i>Regional Markings</i>	<i>Action/Recommendation</i>
<i>Passenger Car Tyres and LT/C Tyres</i>	
Marks of treadwear indicator (TWI) location	Tread wear indicators should be identified by the acronym ‘TWI’, or by means of a triangle, or by an arrow radially arranged on the tyre, or else by a symbol determined by the manufacturer. These indications should be moulded on the both sides of the sidewall in the tyre shoulder region. A Contracting Party may at the national level require fewer treadwear indicators on tyres than UN GTR No. 16 specifies.
Production Code	A production code marking is not included in UN GTR No. 16. A Contracting Party may at the national level allow an additional optional regional marking on tyres.
Inspection Mark	UN GTR No. 16 does not require an inspection mark. A Contracting Party may at the national level allow an additional optional regional marking on tyres.

Driving direction for tread pattern	This type of marking should be at the discretion of a tyre manufacturer, not required by regulation. This type of marking is not included in UN GTR No. 16.
Name and number of plies	UN GTR No. 16 does not require a mark indicating the name and number of plies. A Contracting Party may at the national level allow an additional optional regional marking on tyres.
<i>LT/C Tyres only</i>	
"ULT" for mini-type truck tyres	UN GTR No. 16 does not require a mark for "ULT". A Contracting Party may at the national level allow an additional optional regional marking on tyres.
"Regroovable"	LT/C tyres that have a TWI should not be regrooved.
Ply rating	UN GTR No. 16 does not require a mark for ply rating. For reference, a table converting ply rating to load range is included in the technical rationale. A Contracting Party may at the national level allow an additional optional regional marking on tyres.

vii. Other Clarifications and Improvements

88. The informal working group did not harmonize the endurance tests for LT/C tyres. The informal working group streamlined the non-harmonized endurance provisions by presenting them as two different non-harmonized tests for potential transposition to the national/regional legislation of the Contracting Parties to the 1998 Agreement. Contracting Parties may utilize either or both tests for transposition. The first test is based on the provisions of FMVSS 139, and it is applicable for all LT/C tyres regardless of speed rating. This option consists of two components: the endurance test and the low inflation pressure performance test, which must be performed in sequence, using the same tyre and rim assembly. The second test is based on UN Regulation No. 54 and is applicable only to tyres with speed symbols below "Q".

89. The informal working group discussed whether to remove the publication year of the ASTM standards for the various standard reference test tyre (SRTT) standards. The informal working group agreed to remove the revision years from the ASTM SRTT standards listed in UN GTR No. 16 but recognized that a Contracting Party may choose to include a revision year in its national regulations even though it may be difficult or impossible to obtain and impossible to verify a SRTT from a previous revision year. The informal working group reviewed the detailed and rigorous quality assurance and control measures in place to assure that SRTT performance remains consistent. The validation process includes validation of both the tread rubber and the finished tyre. The tread rubber is validated by testing samples in both the manufacturer's laboratory and an independent laboratory to assure material properties. Tyre quality and performance are validated by taking a random sample of ten tyres from each build and subjecting them to physical and chemical measurements and a range of tyre

performance tests, including both regulatory and proprietary tests. In addition, the informal working group noted that the revision year is not included on the sidewall of any SRTT. The informal working group recognized a distinction between listing the revision year for an SRTT standard and listing a revision year for a tyre testing standard, where substantive provisions may change from revision to revision.

90. The informal working group reviewed the list of tyre standards organizations listed in Annex 7 for completeness and added Associacao Latino Americana de Pneus e Aros (Brazil) (ALAPA) to the list.

viii. Future Work

91. The informal working group recommends that discussions continue regarding the viability of a potential global mark for tyres that meet all requirements specified in UN GTR No. 16. During the development of Amendment 2, Russian Federation presented a proposal to develop a global mark as part of UN GTR No. 16. The informal working group held some discussions on the proposal but did not develop a recommendation in this area.

92. Industry recommends that UN Regulation Nos. 30 and 54 be amended to remove the maximum outer growth diameter requirements for radial tyres that have completed the high-speed performance test and the load/speed endurance test. Once these provisions are removed from UN Regulation Nos. 30 and 54, the industry would support their removal from UN GTR No. 16 as well in a future amendment.

93. The informal working group recommends that potential future amendments be considered pursuant to articles 6.3 and 6.4 of the 1998 Agreement when UN Regulations, FMVSS or other relevant regulations are amended.

II. Text of the global technical regulation

1. Scope

- 1.1. This global technical regulation covers new radial **pneumatic** tyres referred to as 'tyres' in this document designed primarily for vehicles in Categories 1 and 2, all with a gross vehicle mass of 4,536 kg or less, as defined in the Special Resolution No. 1.⁴
- 1.2. **This global technical regulation** does not apply to:
- (a) T-Type temporary use spare tyres;
 - (b) Tyres having a nominal rim diameter code ≤ 8 (or ≤ 203 mm).
 - (c) Special Tyres (ST) for trailers in highway service;
 - (d) LT or C tyres with tread-depth of greater than or equal to 14.3 mm (18/32 inch)
 - (e) **Class C3 tyres except those with Load Index between 122 and 131 that contain "LT" or "C" in the size designation.**
- 1.3. **The definitions for the different kinds of tyres are provided in section 2 of this regulation.**

2. Definitions

For the purpose of this regulation the following definitions apply:

- 2.1. "*Acceleration test*" means a series of specified number of traction-controlled acceleration test runs of the same tyre repeated within a short timeframe;
- 2.2. "*Adhesion on wet surfaces*" means the relative braking performance, on a wet surface, of a test vehicle equipped with the candidate tyre in comparison to that of the same test vehicle with a Standard Reference Test Tyre (SRTT);
- 2.3. **"Metric-A tyre" or "Metric-U tyre" means a Metric tyre with a "A" or "U" suffix indicating a passenger car tyre intended to be used on specific rims; refer to Annex 4 for examples;**
- 2.4. "*Basic tyre functions*" means the nominal capability of an inflated tyre in supporting a given load up to a given speed and transmitting the driving, the steering and the braking forces to the ground on which it runs;
- 2.5. "*Bead*" means the part of the tyre which is of such shape and structure as to fit the wheel rim and hold the tyre on it;
- 2.6. "*Bead separation*" means a breakdown of the bond between components in the tyre bead area;
- 2.7. "*Braking force of a tyre*" means the longitudinal force, expressed in newtons, resulting from braking torque application;
- 2.8. "*Braking force coefficient of a tyre (BFC)*" means the ratio of the braking force to the vertical load;

⁴ Document ECE/TRANS/WP.29/1045, as amended.

-
- 2.9. "Braking test" means a series of a specified number of ABS-braking test runs of the same tyre repeated within a short time frame;
- 2.10. "Brand name/trademark" means the identification of the brand or trademark as defined by the tyre manufacturer and marked on the sidewall(s) of the tyre. The brand name/trademark may be the same as that of the manufacturer;
- 2.11. "Candidate tyre(s)" means a tyre or a tyre set that is tested for the purpose of calculating its wet or snow grip index;
- 2.12. "Capped inflation" means the process of inflating the tyre and allowing the inflation pressure to build up as the tyre is warmed up while running;
- 2.13. "Carcass" means that part of the tyre structure other than the tread and sidewall rubber, which, when inflated, bears the load;
- 2.14. "Chunking" means the breaking away of pieces of the tread or sidewall;
- 2.15. "Class C1 tyres" means tyres designed primarily for vehicles of Category 1-1 of Special Resolution No. 1;
- 2.16. "Class C2 tyres" means tyres designed primarily for vehicles of Categories 1-2 and 2 of Special Resolution No. 1 with a load index in single application ≤ 121 and the speed symbol \geq "N";
- 2.17. "Class C3 tyres" means tyres designed primarily for vehicles of Category 2 of Special Resolution No. 1 with a load index in single application ≤ 121 and the speed symbol \leq "M", or with a load index in single application ≥ 122 ;
- 2.18. "Control tyre" means a normal production tyre that is used to establish the wet grip or snow grip performance of tyre sizes unable to be fitted to the same vehicle as the standard reference test tyre;
- 2.19. "Cord" means the strands or filaments of material forming the plies of the tyre structure;
- 2.20. "Cord separation" means the parting of cords from adjacent rubber compounds;
- 2.21. "Coupling (hitch) height" means the height when measured perpendicularly from the centre of the articulation point of the trailer towing coupling or hitch to the ground, when the towing vehicle and trailer are coupled together. The vehicle and trailer shall be standing on level pavement surface in its test mode complete with the appropriate tyre(s) to be used in the particular test;
- 2.22. "CP tyre" means a commercial vehicle tyre for service on motor caravans;
- 2.23. "Cracking" means any parting within the tread, sidewall or inner liner of the tyre which may or may not extend to cord material;
- 2.24. "Deflected section height" is the difference between the deflected radius, measured from the centre of the rim to the surface of the drum, and one half the nominal rim diameter as defined in ISO 4000-1:2010;
- 2.25. "Extra Load" means a tyre structure designed to carry more load at a higher inflation pressure than the load carried by the corresponding standard version tyre at the standard inflation pressure as specified in ISO 4000-1:2010;
- 2.26. "Flat tyre running mode" describes the state of the tyre, essentially maintaining its structural integrity, while operating at an inflation pressure between 0 and 70 kPa, for runflat tyres or systems;

- 2.27. "High flotation tyre" means an LT/C tyre which is dimensionally larger and operates at a lower inflation pressure than the tyre it replaces to provide improved flotation in off-the-road service. Refer to Annex 4 for examples;
- 2.28. "Inner liner" means the layer of rubber forming the inside surface of a tubeless tyre that contains the inflating medium within the tyre;
- 2.29. "Inertia or moment of inertia" means the ratio of the torque applied to a rotating body to the rotational acceleration of this body⁵;
- 2.30. "Intended outboard sidewall" means the sidewall that contains a whitewall, bears white lettering, or bears manufacturer or model name moulding that is higher or deeper than that on the other sidewall of the tyre;
- 2.31. "Laboratory Control Tyre" means the tyre used by an individual laboratory to control machine behaviour as a function of time;
- 2.32. "Light load tyre (LL)" means a tyre designed for loads lower than the standard load (SL) version;
- 2.33. "Light truck or commercial tyre" also referred to as "LT/C tyres" in this document, means a tyre of a group prescribed in the "LT" Light Truck or "C-type" Commercial or "CP-type" Commercial tyre section of the standards manuals of the organizations shown in Annex 7; Refer to Annex 4 for examples;
- 2.34. "Load index" means a numerical code which indicates the maximum load rating. The list of these indices and their corresponding reference loads is given in Annex 2;
- 2.35. "Load capacity" means the maximum load that a tyre is able to carry subject to the tyre operating speed, the tyre speed symbol and the tyre class. Annex 5 specifies the Tyre Load Capacity variation for Class C1 (Passenger Car) and Class C2 or Class C3 (LT/C) tyres;
- 2.36. "Load range" means a letter (B, C, D, or E) used to identify a given LT/C tyre with its load classification and inflation limits, as per table below:

Table 1

Load Range Table for Reference Test Inflation Pressure

Reference Test Inflation Pressure Range (kPa)	Load range for Nominal section width	
	≤ 295mm	> 295mm
170 – 199	Not Applicable	B
200 – 299	B	C
300 – 399	C	D
400 – 499	D	E
500 – 599	E	Not Applicable

- 2.37. "Lockup of a wheel" means the condition of a wheel in which its rotational velocity about the wheel spin axis is zero and it is prevented from rotating in the presence of applied wheel torque;

⁵ The rotating body can be, for example, a tyre assembly or machine drum.

- 2.38. "Manufacturer" means the person or body who is responsible to the Regulatory Authority for all aspects of the approval or certification and for ensuring the conformity of production;
- 2.39. "Measurement reproducibility σ_m " means the capability of a machine to measure rolling resistance⁶;
- 2.40. "Maximum load rating" means the reference mass corresponding to the load index used to define the load capacity of the tyre;
- 2.41. "Maximum permissible inflation pressure" means the maximum cold inflation pressure to which the tyre may be inflated;
- 2.42. "Mean fully developed deceleration ("mfdd")" means the average deceleration calculated on the basis of the measured distance recorded when decelerating a vehicle between two specified speeds;
- 2.43. "Measuring rim width" means a particular rim width as defined in Annex 9, except for the sizes listed in Annex 6, where the measuring rim width is obtained by multiplying the measuring rim width code indicated in the table by 25.4;
- 2.44. "Metric tyre" means a tyre which has its nominal section width denomination expressed in mm and the aspect ratio expressed as a percentage or the outer diameter expressed in mm as part of the size designation. Refer to Annex 4 for examples;
- 2.45. "Minimum and maximum rim widths" define a range of rim widths to which the tyre can be fitted for testing, as specified for the relevant tests;
- 2.46. "Nominal aspect ratio (profile)" means the ratio of the nominal section height to the nominal section width expressed as a percentage in a multiple of 5 (ending in 0 or 5);
- 2.47. "Nominal section width" is a theoretical standardised section width, which is part of the tyre size designation. The nominal section width of the tyre shall be indicated in millimeters (mm) except in the case of high flotation tyres. In the case of High flotation sizes, it is expressed by a code that will end in « .50 » and its value is given in mm and is obtained by multiplying the code by 25.4 and rounded as indicated in the table 3 in paragraph 3.5.2.2.1. For the existing types of tyres whose designation is given in the first column of the tables in Annex 6 to this regulation, the nominal section width shall be deemed to be that given opposite the tyre designation in those tables;
- 2.48. "Normal tyre" means a tyre intended for normal on-road use;

⁶ Measurement reproducibility σ_m shall be estimated by measuring n times (where $n \geq 3$), on a single tyre, the whole procedure described in paragraph 3.13.5 as follows:

$$\sigma_m = \sqrt{\frac{1}{n-1} \cdot \sum_{j=1}^n \left(Cr_j - \frac{1}{n} \cdot \sum_{j=1}^n Cr_j \right)^2}$$

Where:

j = is the counter from 1 to n for the number of repetitions of each measurement for a given tyre,

n = number of repetitions of tyre measurements ($n \geq 3$).

Cr = coefficient of rolling resistance measured

- 2.49. "Open splice" means any parting at any junction of tread, sidewall, or inner liner that extends to cord material;
- 2.50. "Outer diameter" means the overall diameter of an inflated new tyre;
- 2.51. "Overall width" means the linear distance between the outsides of the sidewalls of an inflated tyre, including elevations due to labelling (marking), decorations, and/or protective bands or ribs;
- 2.52. "Parasitic loss" means loss of energy (or energy consumed) per unit distance excluding internal tyre losses, attributable to aerodynamic loss of the different rotating elements of the test equipment, bearing friction and other sources of systematic loss which may be inherent in the measurement;
- 2.53. "Passenger car tyre" means a tyre of a group prescribed in the passenger car tyre section of the standards manuals from one of the organizations shown in Annex 7;
- 2.54. "Peak brake force coefficient ("pbfc")" means the maximum value of a tyre braking force coefficient that occurs prior to wheel lockup as the braking torque is progressively increased;
- 2.55. "Ply" means a layer of rubber-coated parallel cords;
- 2.56. "Ply separation" means a parting of adjacent plies;
- 2.57. "Tyre" means a form of tyre comprising a reinforced flexible envelope which is either provided with, or forms in conjunction with the wheel upon which it is mounted, a continuous, closed, essentially toroidal chamber containing a gas, (usually air), or gas and a liquid, which is intended to be used at a pressure greater than atmospheric pressure. A tyre may be classified as a passenger car tyre (see "passenger car tyre" above), or an LT/C tyre, depending on the service duty conditions required for any specific application;
- 2.58. "P- Metric tyre" is a type of metric Passenger car tyre with a "P" prefix in the tyre size designation indicating specific dimensions of such tyre; Refer to Annex 4 for examples;
- 2.59. "Principal grooves" means the wide circumferential grooves positioned in the central zone of the tyre tread, which, in the case of passenger car and LT/C tyres, have the tread wear indicators located in the base;
- 2.60. "Professional off-road tyre" is a special use tyre primarily used for service in severe off-road conditions;

In order to be classified as a 'professional off-road tyre', a tyre shall have all of the following characteristics:

- (a) For Class C1 and Class C2 tyres:
- (i) A tread depth ≥ 11 mm;
 - (ii) A void-to-fill ratio ≥ 35 per cent;
 - (iii) A maximum speed symbol $\leq Q$;
- (b) For Class C3 tyres:
- (i) A tread depth ≥ 16 mm;
 - (ii) A void-to-fill ratio ≥ 35 per cent;
 - (iii) A maximum speed symbol $\leq K$;

- 2.61. "Reference Test Inflation Pressure" applicable for LT/C tyres means the minimum cold inflation pressure for the maximum load rating of the tyre in single application;
- 2.62. "Radial ply tyre" means a tyre structure in which the ply cords that extend to the beads are laid at substantially 90° to the centreline of the tread, the carcass being restrained by circumferential belts of 2 or more layers of substantially inextensible cord material;
- 2.63. "Rim" means that part of the wheel forming the support for the tyre and on which the tyre beads are seated;
- 2.64. "Rim protector" means a feature (for example: a protruding circumferential rubber rib) incorporated into the lower sidewall area of the tyre which is intended to protect the rim flange from damage;
- 2.65. "Rolling resistance coefficient C_r " means the ratio of the rolling resistance to the load on the tyre⁷;
- 2.66. "Rolling resistance F_r " means the loss of energy (or energy consumed) per unit of distance travelled⁸;
- 2.67. "Run flat tyre" or "Self-supporting tyre" describes a tyre structure provided with any technical solutions (for example, reinforced sidewalls, etc.) allowing the tyre, mounted on the appropriate wheel and in the absence of any supplementary component, to supply the vehicle with the basic tyre functions, at least, at a speed of 80 km/h (50 mph) and a distance of 80 km when operating in flat tyre running mode;
- 2.68. "Run flat system" or "Extended mobility system" describes an assembly or specified functionally dependant components, including a tyre, which together provide the specified performance granting conditions for the vehicle with at least basic tyre functions, at a speed of 80 km/h (50 mph) and a distance of 80 km (50 miles) when operating in flat tyre running mode;
- 2.69. "Secondary grooves" means the supplementary grooves of the tread pattern which may disappear in the course of the tyre's life;
- 2.70. "Section height" means a distance equal to half the difference between the outer diameter of the tyre and the nominal rim diameter;
- 2.71. "Section width" means the linear distance between the outside of the sidewalls of an inflated tyre, excluding elevations due to labelling (marking), decoration or protective bands or ribs;
- 2.72. "Service description" means the association of the load index or indices with a speed symbol (for example, 91H or 121/119S);
- The service description of an LT/C tyre may include either one or two load indices which indicate the load the tyre can carry in single or in single and dual operation. In addition, an LT/C tyre can have an alternative service description;
- 2.73. "Sidewall" means that portion of a tyre between the tread and the bead;

⁷ The rolling resistance is expressed in newtons and the load is expressed in kilonewtons. The rolling resistance coefficient is dimensionless.

⁸ The International System of Units (SI) unit conventionally used for the rolling resistance is the newton meter per meter, which is equivalent to a drag force in newtons.

- 2.74. "Sidewall separation" means the parting of the rubber compound from the cord material in the sidewall;
- 2.75. "Skim test reading" means the type of parasitic loss measurement, in which the tyre is kept rolling without slippage, while reducing the tyre load to a level at which energy loss within the tyre itself is virtually zero;
- 2.76. "Snow grip index (SG)" means the ratio between the performance of the candidate tyre and the performance of the standard reference test tyre;
- 2.77. "Snow tyre" means a tyre whose tread pattern, tread compound or structure is primarily designed to achieve in snow conditions a performance better than that of a normal tyre with regard to its ability to initiate or maintain vehicle motion;
- 2.78. "Snow tyre for use in severe snow conditions" means a snow tyre whose tread pattern, tread compound or structure is specifically designed to be used in severe snow conditions and that fulfils the requirements in paragraph 3.14;
- 2.79. "Special Tyres (ST) for trailers in highway service" means a tyre having the ST prefix or suffix in the tyre size. These tyres have higher allowable loads than the corresponding sized tyres without the ST designation and consequently are only allowed for use on trailers;
- 2.80. "Special use tyre" means a tyre intended for mixed use, both on and/or off road or for other special service duty. These tyres are primarily designed to initiate and maintain the vehicle in motion in off-road conditions;
- In order to be classified as a "special use tyre" a tyre shall have a block tread pattern in which the blocks are larger and more widely spaced than for normal tyres and have the following characteristics:
- For Class C1 tyres: a tread depth ≥ 11 mm and void to fill ratio ≥ 35 per cent
- For Class C2 tyres: a tread depth ≥ 11 mm and void to fill ratio ≥ 35 per cent
- For Class C3 tyres: a tread depth ≥ 16 mm and void to fill ratio ≥ 35 per cent
- 2.81. "Speed symbol" means the letter code which defines the maximum speed which the tyre can sustain, (see Annex 1 to this regulation);
- 2.82. "Standard Reference Test Tyre (SRTT)" means a reference tyre that is produced, controlled and stored in accordance with the ASTM International (ASTM) standards: The following SRTT's are used for the purpose of this regulation.
- (a) E1136 for the size P195/75 R 14
- (b) F2493 for the size P225/60 R 16
- (c) F2872 for the size 225/75 R 16 C
- (d) F2871 for the size 245/70 R 19.5
- (e) F2870 for the size 315/70 R 22.5
- 2.83. "Structure" means the technical characteristics of the tyre's carcass (for example: radial, bias-belted, bias ply, run flat etc.);
- 2.84. "SRTT14" means the ASTM E 1136, Standard Specification for a Radial Standard Reference Test Tyre P195/75R14;

- 2.85. "SRTT16" means the ASTM F 2493, Standard Specification for a Radial Standard Reference Test Tyre P225/60R16;
- 2.86. "Temporary use spare tyre" means a tyre different from a tyre fitted to a vehicle for normal driving conditions, and intended only for temporary use under restricted driving conditions;
- 2.87. "Test rim" means the rim on which a tyre is fitted for testing;
- 2.88. "Test run" means a single pass of a loaded tyre over a given test track surface;
- 2.89. "Test tyre(s)" means a candidate tyre, a reference tyre or a control tyre or tyre set that is used in a test run;
- 2.90. "Theoretical rim width" means a rim width specified in Annex 9 and used to determine the tyre physical dimensions. The theoretical rim width is expressed in mm;
- 2.91. "Spin traction test" means a series of a specified number of spin-traction test runs according to ASTM standard F1805-06 of the same tyre repeated within a short time frame;
- 2.92. "Traction tyre" means a tyre in Class C2 or Class C3 bearing the inscription TRACTION and intended to be fitted primarily to the drive axle(s) of a vehicle to maximize force transmission in various circumstances;
- In order to be classified as a "traction tyre", a tyre is required to meet at least one of the following conditions:
- The tyre shall have a tread pattern with minimum two circumferential ribs, each containing a minimum of 30 block-like elements, separated by grooves and/or sipe elements the depth of which has to be minimum of one half of the tread depth;
- 2.93. "Trade description/commercial name" means an identification of a range of tyres as given by the tyre manufacturer. It may coincide with the brand name/trademark;
- 2.94. "Tread" means that part of a tyre that comes into contact with the road;
- 2.95. "Tread pattern groove" means the space between two adjacent ribs or blocks in the tread pattern;
- 2.96. "Tread depth" means the depth of the principal grooves;
- 2.97. "Tread pattern" means the geometric arrangement of blocks, ribs and grooves of the tread;
- 2.98. "Tread separation" means the pulling away of the tread from the tyre carcass;
- 2.99. "Tread Wear Indicators (TWI)" means the projections within the principal grooves designed to give a visual indication of the wear of the tread;
- 2.100. "Tubeless tyre" means a tyre specifically designed for fitting to appropriate wheel rims without an inner tube;
- 2.101. "T-type temporary use spare tyre" means a type of temporary use spare tyre designed for use at inflation pressures higher than those established for standard and extra load tyres;
- 2.102. "Tyre size designation" means a combination of letters, numbers and symbols which uniquely identify the size and structure of the tyre as set out in one of

the standards of the organizations listed in Annex 7 or in the tables in Annex 6 to this regulation. Refer to Annex 4 for tyre size designation descriptions;

- 2.103. *"Tyre test vehicle"* means a dedicated special purpose vehicle which has instruments to measure the vertical and the longitudinal forces on one test tyre during braking;
- 2.104. *"Vertical load"* means the load in newtons imposed on the tyre perpendicular to the road surface;
- 2.105. *"Void to fill ratio"* means the ratio between the area of voids in a reference surface and the area of this reference surface calculated from the mould drawing;
- 2.106. *"Wet grip index ("G")"* means the ratio between the performance of the candidate tyre and the performance of the standard reference test tyre.

3. Requirements

In case specific tolerances are not mentioned in the section 3. of this regulation, guidelines are provided in Annex 11.

- 3.1. Plant codes
 - 3.1.1. Plant code registration for manufacturers with a representative in the United States of America
 - 3.1.1.1. Each tyre manufacturer of new tyres shall apply in writing to the following address for registration and allocation of a manufacturer plant code identification symbol:
Office of Vehicle Safety Compliance
National Highway Traffic Safety Administration
1200 New Jersey Avenue, SE
Washington, D.C. 20590, United States of America
 - 3.1.1.2. The tyre manufacturer requesting a plant code assignment shall identify itself as the tyre manufacturer and declare the following information in the application and shall inform the NHTSA of any changes to the information:
 - 3.1.1.3. The name or other designation identifying the applicant, and its main office address;
 - 3.1.1.4. The name, or other identifying designation, of each individual plant operated by the manufacturer and the address of each plant, if applicable;
 - 3.1.1.5. The type of tyres manufactured at each plant; e.g., tyres for passenger cars, buses, trucks or motorcycles; pneumatic retreaded tyres; or non-pneumatic retreaded tyres; or non-pneumatic tyre assemblies.
 - 3.1.2. Plant code for manufacturers with no specified representative in the United States of America
 - 3.1.2.1. The plant code for tyres manufactured by companies with no specified representative in the United States of America shall be 999.

-
- 3.2. Marking
- 3.2.1. The Tyre Identification Number is a series of numbers, letters and spaces in the format `YYY_MMMMMM_DDDD`.
- 3.2.1.1. The YYY is a 3-digit universal plant code for the place of manufacture of the tyre.
- 3.2.1.2. The MMMMM is a 6-digit manufacturer's code. Within the tyre identification number format, this shall be a 6-digit required field, but the content is at the discretion of the tyre manufacturer.
- 3.2.1.3. The DDDD with 4 digits represents the week and year of manufacture, also known as the date code. The first two symbols shall identify the week of the year by using "01" for the first full calendar week in each year, "02" for the second full calendar week, and so on. The calendar week runs from Sunday through the following Saturday. The final week of each year shall include not more than 6 days of the following year. The third and fourth symbols shall identify the year. Example: 0110 means the first week of 2010.
- 3.2.1.4. The Tyre Identification Number shall be located on the intended outboard sidewall of the tyre and positioned between the bead and 50 per cent of the distance from the bead to the tread. On the other sidewall of the tyre either a tyre identification number or a partial tyre identification number is required. The partial tyre identification number is comprised of all characters except the date code. If the tyre has no intended outboard sidewall, the complete tyre identification number shall be placed on one sidewall, and a partial or complete tyre identification number shall be placed on the other sidewall.
- 3.2.1.5. The symbols to be used in the tyre identification number format are A, B, C, D, E, F, H, J, K, L, M, N, P, R, T, U, V, W, X, Y, 1, 2, 3, 4, 5, 6, 7, 8, 9, 0.
- 3.2.1.6. The symbols that shall not be used are G, I, O, Q, S, and Z.
- 3.2.1.7. The font to be used for the Tyre Identification Number shall be Futura Bold, Modified Condensed, Gothic, or OCR-B (as defined in ISO 1073-2: 1976).
- 3.2.1.8. The characters shall have a height of at least 6 mm and a positive or negative relief of between 0.5 to 1.0 mm, as measured from the surface in the immediate vicinity of the marking.
- 3.3. Other sidewall markings
- 3.3.1. Unless otherwise stated in this UN GTR No. 16, the following information, together with any other markings required by provisions in Annexes to this regulation, shall be legibly and permanently moulded into or onto the sidewall(s):
- 3.3.1.1. In the case of asymmetric tyres on the intended outboard sidewall as viewed when the tyre is fitted to the vehicle;
- 3.3.1.2. In either case, on at least one sidewall, the required markings shall be in a position on the sidewall where they are least susceptible to being "scrubbed" away during use;
- 3.3.1.2.1. The manufacturer's name or the brand name/trademark in characters not less than 4 mm high.
- 3.3.1.2.2. The trade description/commercial name (see paragraph 2.93 of this Regulation) in characters not less than 4 mm high. However, the trade description is not required when it coincides with the brand name/trademark.

- 3.3.1.2.2. The country of manufacture in characters not less than 2 mm high;
- 3.3.1.2.3. The tyre size designation in characters not less than 6 mm high comprising:
- 3.3.1.2.3.1. An indication of the tyre structure;
- 3.3.1.2.3.1.1. R for radial construction;
- 3.3.1.2.3.1.2. RF for radial run flat tyre;
- 3.3.1.2.3.2. The service description and if applicable alternative service description;
- 3.3.1.2.3.3. An identification of the tyre to rim fitment configuration when it differs from the standard configuration.

3.3.1.2.3.3.1. In the case of LT and C tyres, the words "Load Range" or "LR" followed by the letter designating the tyre load range "B, C, D, or E".

3.3.2. Each tyre shall be labelled on the other side (from that directed in paragraph 3.2.1.4 above) with the same tyre identification number except for the date code and, at the discretion of the manufacturer, any optional code on the other sidewall.

3.3.3. For tyres suitable for speed in excess of 300 km/h, the letter "R" placed in front of the rim diameter code symbol marking shall be replaced by "ZR" and the tyre shall be marked, in parentheses, with a service description consisting of the speed symbol "Y" and a corresponding load index, for example, 245/45ZR17 (95 Y).

Note: The maximum speed permitted by the tyre manufacturer and the corresponding load capacity for that maximum speed shall be stated in the tyre manufacturer's technical literature and made available to the public.

3.3.4. For passenger car tyres, each tyre shall be labelled with its maximum permissible inflation pressure in kPa (psi) and shall be labelled with its maximum load rating in kilograms (lbs).

3.3.5. In the case of LT/C tyres, the maximum load rating and corresponding inflation pressure of the tyre, shown as follows:

"Max load single _____ kg (_____ lb) at _____ kPa (_____ psi) cold
Max load dual _____ kg (_____ lb) at _____ kPa (_____ psi) cold"

For LT/C tyres rated for single fitment only, mark as follows:

"Max load single _____ kg (_____ lb) at _____ kPa (_____ psi) cold "

The inflation pressure marked for single application shall be taken as the Reference Test Inflation Pressure, unless a different value for the Reference Test Inflation Pressure is marked separately as follows⁹:

"Max load single _____ kg (_____ lb) at _____ kPa (_____ psi) cold
Max load dual _____ kg (_____ lb) at _____ kPa (_____ psi) cold"

TEST AT: _____ kPa¹⁰

⁹ In line with the definition of the Reference Test inflation Pressure, the inflation pressure marked for single application (and dual application if applicable) shall be equal or higher than the Reference Test Inflation Pressure.

¹⁰ May be replaced by « TEST INFL : » or the symbol « @ »

For LT/C tyres rated for single fitment only, mark as follows:

"Max load single kg (lb) at kPa (psi) cold

TEST AT: kPa"¹¹

When implementing this paragraph, the Contracting Parties may limit the difference between the inflation pressure(s) marked for single application (and dual application if applicable) and the Reference Test Inflation Pressure.

- 3.3.6. The inscription "EXTRA LOAD" or "XL" for extra load tyres, or the inscription "LL" or "LIGHT LOAD" for light load tyres, if applicable, in characters not less than 4 mm high;
- 3.3.7. The word "TUBETYPE", if applicable, in characters not less than 4 mm high;
- 3.3.8. The inscription "M+S", "M.S.", "M&S", "M-S", or "M/S", in characters not less than 4 mm high, if the tyre is a snow tyre or optionally if the tyre is a special use tyre;
- 3.3.9. The "Alpine" symbol ("3-peak-mountain with snowflake") which identifies a snow tyre classified as "snow tyre for use in severe snow conditions". The symbol shall have a minimum base of 15 mm and a minimum height of 15 mm and shall contain three peaks with the middle peak being the tallest. Inside the mountain, there shall be a six-sided snowflake having a minimum height of one-half the tallest peak. An example is shown below, and is to be placed adjacent to an inscription as listed in paragraph 3.3.8;

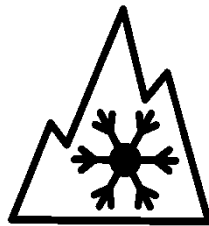

- 3.3.10. The symbol below if the tyre is a "run flat" or "self-supporting" tyre, and performance requirements for run flat tyres are met as per paragraph 3.10.1, where "h" is at least 12 mm.

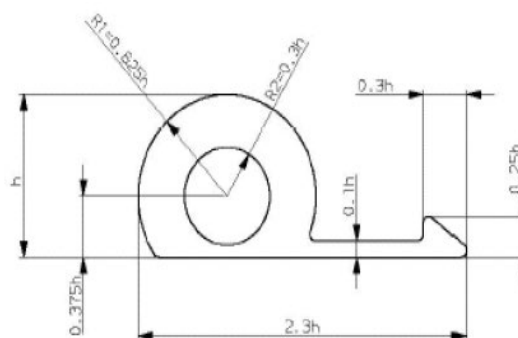

¹¹ May be replaced by « TEST INFL : » or the symbol « @ »

- 3.3.11. In the case of LT or C tyres classified as "traction tyre", the inscription "TRACTION";
- 3.3.12. In the case of LT or C tyres, the inscription "ET" or "ML" or "MPT" and / or "POR" for "Special use tyres":
- 3.3.12.1. ET = Extra Tread;
- 3.3.12.2. ML = Mining and Logging tyre used in intermittent highway service;
- 3.3.12.3. MPT = Multi-Purpose Truck tyres.
- 3.3.12.4. POR = Professional Off-Road tyres.
- 3.3.12.5. In addition, they may also bear the inscription M+S or M.S or M&S.
- 3.3.13. In the case of LT or C tyres, the prefix "LT" before the tyre size designation, or the suffix "C" or "LT" after the rim diameter marking referred to in Annex 3, and, if applicable, after the tyre to rim fitment configuration referred to in paragraph 3.3.1.2.3.3. or the suffix "LT" after the service description
- 3.3.14. In the case of CP tyres as defined in 2.22, the suffix "CP" replaces the suffix "C" after the rim diameter marking referred to in Annex 3 and, if applicable, after the tyre to rim fitment configuration referred to in paragraph 3.3.1.2.3.3. This marking is mandatory in the case of tyres fitted on 5° drop centre rims, having a load index in single operation lower or equal to 121 and specifically designed for the equipment of motor caravans.
- 3.4. Tread wear indicators
- 3.4.1. Except as noted below, each passenger car tyre and each LT/C tyre shall have at least six transverse rows of tread wear indicators, approximately equally spaced around the circumference of the tyre and situated in the principal grooves of the tread.
- 3.4.2. For passenger car tyres designed for mounting on rims of nominal rim diameter code 12 or less, not less than three transverse rows of tread wear indicators is acceptable.
- 3.4.3. The tread wear indicators may be identified by the acronym 'TWI', or by means of a triangle, or by an arrow radially arranged on the tyre, or else by a symbol determined by the manufacturer. These indications may be moulded on both sides of the sidewall in the tyre shoulder region.
- 3.4.4. The height of each tread wear indicator shall be $1.6_{-0.0}^{+0.6}$ mm.
- 3.5. Dimensions
- The following paragraphs describe in detail the requirements for determining the reference and the physical dimensions of passenger car tyres and LT/C tyres according to this regulation. The characteristics to be determined are the overall width, and the outer diameter. If these characteristics are within the specified tolerances, the physical dimensions of the tyre are acceptable.
- Definitions (see paragraph 2. of this regulation for detailed definitions of various terms)
- The overall width of the tyre is defined as the average of four measurements of its width at the widest point, including any markings or protective ribs.
- 3.5.1. Dimensions of passenger car tyres
- 3.5.1.1. Reference dimensions

3.5.1.1.1. Section width of a tyre

3.5.1.1.1.1. The section width shall be calculated by the following formula:

$$S = S_1 + K \cdot (A - A_1),$$

Where:

S is the "section width" rounded to the nearest millimeter;

S_1 is the nominal section width (in mm) as shown on the side wall of the tyre in the designation of the tyre as prescribed;

A is the width (expressed in mm) of the test rim;

A_1 is the width (expressed in mm) of the theoretical rim;

A_1 shall be taken to equal S_1 multiplied by the factor x, as specified by the manufacturer, and K shall be taken to equal 0.4.

3.5.1.1.1.2. However, for the types of tyres whose designation is given in the first column of the tables in Annex 6 to this regulation, the section width shall be deemed to be that given opposite the tyre designation in those tables.

3.5.1.1.1.3. However, for metric-A or metric-U tyres, K shall be taken to equal 0.6.

3.5.1.1.2. Outer diameter of tyre

The outer diameter of the tyre shall be calculated by the following formula:

$$D = d + 2 \cdot H$$

Where:

D is the outer diameter in millimeters;

d is the nominal rim diameter as defined in the Nominal rim diameter code table in Annex 3.

H is the nominal section height rounded to the nearest millimeter and is equal to:

$$H = S_1 \cdot 0.01 Ra, \text{ where}$$

S_1 is the nominal section width in millimeters;

Ra is the nominal aspect ratio;

3.5.1.1.2.1. However, for the existing types of tyres whose designation is given in the first column of the tables in Annex 6 to this regulation, the outer diameter shall be deemed to be that given opposite the tyre designation in those tables.

3.5.1.1.2.2. However, for metric-A or metric-U tyres, the outer diameter shall be that specified in the tyre size designation as shown on the sidewall of the tyre.

3.5.1.2. Physical dimensions measurement method

3.5.1.2.1. Mount the tyre on a test rim with a width comprised between the minimum and maximum width as per Annex 9.

3.5.1.2.2. Adjust the pressure to that specified in the table below:

Table 2

Physical dimensions test inflation pressures

<i>Tyre application</i>	<i>Test inflation pressure (kPa)</i>
Standard load, light load	180
Extra load	220

3.5.1.2.3. Condition the tyre, mounted on its rim, at the ambient room temperature between 18 °C and 38 °C for not less than 24 hours.

3.5.1.2.4. Readjust the pressure to that specified in the table above.

3.5.1.2.5. Measure the overall width at four equally spaced points around the tyre, taking the thickness of protective ribs or bands into account. The reported value will be the average of the four measurements rounded to the nearest millimeter.

3.5.1.2.6. Determine the outer diameter by measuring the maximum circumference, dividing the result by 3.1416 (Pi) and rounding to the nearest millimeter.

3.5.1.2.7. Determine the height of the tread wear indicators by measuring the difference between the total depth of the tread pattern groove in the vicinity of the tread wear indicator and the depth to the top of the tread wear indicator. Repeat this measurement for at least one tread wear indicator in each row (minimum of 6 or 3, depending on the rim diameter; a row is the linear sequence of tread wear indicators positioned radially across the tread from one side to the other). At least one tread wear indicator in each principal groove shall be measured (the principal grooves are the wide grooves positioned circumferentially around the tread). Record all of the individual values rounded to the nearest tenth of a millimeter.

3.5.1.3. Physical dimension requirements

3.5.1.3.1. Overall width

3.5.1.3.1.1. The tyre overall width may exceed the section width defined in paragraph 3.5.1.1.1. above by 4 per cent whereby the limits shall be rounded to the nearest mm.

3.5.1.3.1.2. In addition, if the tyre has rim protectors (see definition in paragraph 2.), the figure as increased by the above tolerance may be exceeded by 8 mm.

3.5.1.3.1.3. However, for metric-A or metric-U tyres, the overall width of the tyre, in the lower area of the tyre, equals the nominal width of the rim on which the tyre is mounted, as shown by the manufacturer in the descriptive note, increased by 20 mm.

3.5.1.3.2. Outer diameter

3.5.1.3.2.1. The outer diameter of a tyre shall not be outside the values D_{min} and D_{max} obtained from the following formulae:

$$D_{min} = d + 2 \cdot H_{min}$$

$$D_{max} = d + 2 \cdot H_{max}$$

where:

$$H_{min} = H \cdot a \quad \text{rounded to the nearest mm}$$

$$H_{max} = H \cdot b \quad \text{rounded to the nearest mm}$$

Where the coefficients "a" and "b" are:

coefficient "a" = 0.97

Coefficient "b" = 1.04 for normal tyres and 1.06 for special-use tyres

For snow tyres the outer diameter shall not exceed the following value

$$D_{\text{max.snow}} = 1.01 \cdot D_{\text{max}} \quad \text{rounded to the nearest mm}$$

where D_{max} is the maximum outer diameter established for the normal tyres in conformity with the above.

3.5.1.3.2.2. However, for the types of tyres whose size designation is given in the first column of the tables in Annex 6 to this regulation, and for metric-A or metric-U tyres, the nominal section height H is equal to:

$$H = 0.5 \cdot (D - d), \text{ rounded to the nearest millimeter – for references see paragraph. 3.5.1.1.2.};$$

3.5.1.4. Figure 1: Drawing of normal tyre showing rim diameter (d), outside diameter (D), section height (H) and section width (S) and the rim width (A).

Figure 1

Drawing of a normal tyre showing various dimensions

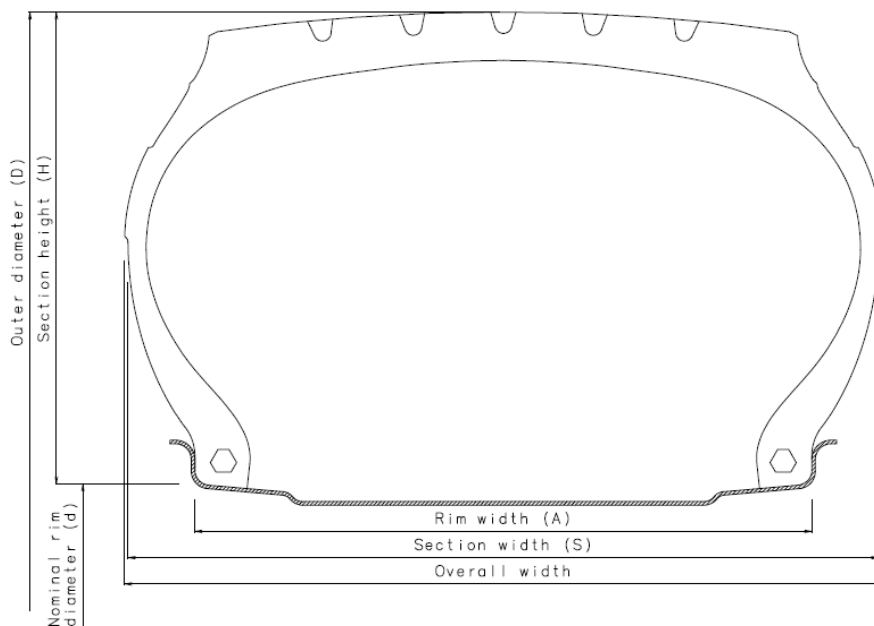

3.5.1.5. For other tyre sizes for which dimensions cannot be calculated, the dimensions including allowance for growth in service, shall comply with those given in standards publications of the organizations listed in Annex 7 and which were current either at the date of manufacture of the tyre or at any later date.

3.5.2. Dimensions of LT/C tyres

3.5.2.1. Reference dimensions for metric tyre sizes (excluding all sizes listed in Annex 6)

3.5.2.1.2. Section width of a tyre

3.5.2.1.2.1. The section width shall be obtained by the following formula:

$$S = S_1 + K \cdot (A - A_1),$$

Where:

S is the section width rounded to the nearest millimeter;

S_1 is the nominal section width (in mm) as shown on the sidewall of the tyre in the designation of the tyre as prescribed;

A is the width (expressed in mm) of the test rim;

A_1 is the width (expressed in mm) of the theoretical rim;

A_1 shall be taken to equal S_1 multiplied by the factor x as specified by the manufacturer, and K shall be taken to equal 0.4.

3.5.2.1.2.3. However, for metric-A tyres, K shall be taken to equal 0.6.

3.5.2.1.3. Outer diameter of a tyre

3.5.2.1.3.1. The outer diameter of a tyre shall be obtained by means of the following formula:

$$D = d + 2 \cdot H$$

Where:

D is the outer diameter in millimeters;

d is the nominal rim diameter in millimeters as defined in the nominal rim diameter code table in Annex 3;

H is the nominal section height rounded to the nearest millimeter and is equal to

$$H = S_1 \cdot 0.01 \cdot Ra, \text{ where}$$

S_1 is the nominal section width in millimeters;

Ra is the nominal aspect ratio;

3.5.2.1.3.1.1. However, for metric-A tyres the nominal section height H is equal to:

$$H = 0.5 \cdot (D - d), \text{ rounded to the nearest mm - for references see paragraph 3.5.2.1.3.1}$$

3.5.2.2. Reference dimensions for high flotation sizes (excluding all sizes listed in Annex 6)

For a description of the high flotation size designation, see example in Annex 4.

To convert dimensions expressed in code to mm, multiply the code by 25.4 and round to the nearest mm.

3.5.2.2.1. Section width of a tyre

The tyre section width is calculated by adjusting the section width value for the measuring rim widths from the table below by 5 mm for each 0.5 change in test rim width code vs the measuring rim width code.

The tyre section widths for the measuring rim widths as specified in paragraph 2.2 of Annex 9 are as follows:

Table 3
Tyre Section Width

Nominal Section Width code	Measuring Rim Width Code ¹²	Tyre Section Width (mm)
7.50	6.00	191
8.50	7.00	218
9.50	7.50	240
10.50	8.50	268
11.50	9.00	290
12.50	10.00	318
13.50	11.00	345
14.50	11.50	367
15.50	12.50	395
16.50	13.00	417
17.50	14.00	445
18.50	15.00	472
19.50	15.50	496

3.5.2.2.2. The outer diameter (D) is calculated as follows:

(a) Traction Tread ¹³

$D \text{ (mm)} = (\text{nominal overall diameter code} - 0.24) \cdot 25.4$, rounded to the nearest mm.

(b) Highway Tread ¹⁴

$D \text{ (mm)} = (\text{nominal overall diameter code} - 0.48) \cdot 25.4$, rounded to the nearest mm.

3.5.2.3. Reference dimensions for sizes listed in Annex 6

The section width for the measuring rim width code and the outer diameter shall be deemed to be those given opposite the tyre size designation in the tables of Annex 6.

If the measuring rim width code is not used, the section width is calculated by adjusting the section width value for the measuring rim widths from the table by 2.5 mm for each 0.25 change in test rim width code vs the measuring rim width code. The section width shall be rounded to the nearest mm.

3.5.2.4. Physical dimensions measurement method

¹² The table reproduces the measuring rim width codes defined in Annex 9 for purpose of clarity.

¹³ Traction Tread tyres are those bearing at least one of the following inscriptions:

- Inscription(s) defined in paragraph 3.3.12.
- Alpine symbol (3-peak-mountain with snowflake) as defined in paragraph 3.3.9 and meeting the requirements of section 3.14.1
- TRACTION inscription as defined in paragraph 3.3.11.

¹⁴ Highway Tread tyres are all tyres that are not Traction Tread.

3.5.2.4.1. Mount the tyre on a test rim with a width comprised between the minimum and maximum width as per Annex 9. The rim contour shall be one of those specified for the fitment of the test tyre.

3.5.2.4.2. Inflate the tyre to the Reference Test Inflation Pressure.

3.5.2.4.3. Condition the tyre, mounted on its rim, at the temperature between 18 °C and 38 °C for not less than 24 hours.

3.5.2.4.4. Adjust the pressure to that defined in 3.5.2.4.2

3.5.2.4.5. Measure the overall width at four equally spaced points around the tyre, taking the thickness of protective ribs or bands into account. The reported value will be the average of the four measurements rounded to the nearest millimeter.

3.5.2.4.6. Determine the outer diameter by measuring the maximum circumference, dividing the result by 3.1416 (Pi) and rounding to the nearest millimeter.

3.5.2.4.7. Determine the height of the tread wear indicators by measuring the difference between the total depth of the tread pattern groove in the vicinity of the tread wear indicator and the depth to the top of the tread wear indicator. Repeat this measurement for at least one tread wear indicator in each row (minimum of 6 or 3, depending on the rim diameter; a row is the linear sequence of tread wear indicators positioned radially across the tread from one side to the other). At least one tread wear indicator in each principal groove shall be measured (the principal grooves are the wide grooves positioned circumferentially around the tread). Record all of the individual values rounded to the nearest tenth of a millimeter.

3.5.2.5. Physical dimension requirements

3.5.2.5.1. Metric tyre sizes (excluding all sizes listed in Annex 6)

3.5.2.5.1.1. Overall width

3.5.2.5.1.1.1. The overall width of a tyre may be less than the section width or widths determined pursuant to paragraph 3.5.2.1.2. above.

3.5.2.5.1.1.2. It may exceed that value by 4 per cent. The respective limits shall be rounded to the nearest millimeter (mm).

3.5.2.5.1.1.2.1. However, for LT/C tyres belonging to a group prescribed in the "C-type" commercial or "CP-type" commercial tyre sections of the ETRTO Standards Manual or in the sections "B" or "S" of the JATMA Year Book, tyres with nominal section width exceeding 305 mm and aspect ratio higher than 60 designed for dual mounting (twinning), the overall width of the tyre may exceed the value determined pursuant to paragraph 3.5.2.1.2. by 2 per cent. The respective limits shall be rounded to the nearest millimeter (mm).

This paragraph does not apply to tyres included by the other tyre standards organisations listed in Annex 7 of this regulation.

3.5.2.5.1.1.3. However, for metric-A tyres, the overall width of the tyre, in the lower area of the tyre, equals the nominal width of the rim on which the tyre is mounted, as shown by the manufacturer in the descriptive note, increased by 27 mm.

3.5.2.5.1.2. Outer diameter

3.5.2.5.1.2.1. The outer diameter of a tyre shall not be outside the range D_{min} and D_{max} obtained from the following formulae:

$$D_{min} = d + (2 \cdot H_{min})$$

$$D_{\max} = d + (2 \cdot H_{\max})$$

Where $H_{\min} = H \cdot a$, rounded to the nearest mm

$$H_{\max} = H \cdot b$$
, rounded to the nearest mm

"H" and "d" are as defined in paragraph 3.5.2.1.3.1

Coefficient 'a' for the calculation of H_{\min} :

$$a = 0.97$$

Coefficient "b" for the calculation of H_{\max} :

For normal tyres, $b = 1.04$

For snow tyres the outer diameter shall not exceed the following value: $D_{\max, \text{snow}} = 1.01 \cdot D_{\max}$, rounded to the nearest mm, where D_{\max} is the maximum outer diameter established for normal tyres above.

For special use tyres, $b = 1.06$

3.5.2.5.2 High flotation sizes (excluding all sizes listed in Annex 6)

3.5.2.5.2.1 Overall width

3.5.2.5.2.1.1. The overall width of a tyre may be less than the section width or widths determined pursuant to paragraph 3.5.2.2.2. above.

The overall width of a tyre may exceed the section width or widths determined pursuant to paragraph 3.5.2.2.2. by up to +7%.

3.5.2.5.2.2. Outer diameter

3.5.2.5.2.2.1. The outer diameter of a tyre shall not be outside the range D_{\min} and D_{\max} obtained from the following formulae:

$$D_{\min} = d + (2 \cdot H_{\min})$$

$$D_{\max} = d + (2 \cdot H_{\max})$$

Where $H_{\min} = H \cdot a$, rounded to the nearest mm

$$H_{\max} = H \cdot b$$
, rounded to the nearest mm

$$H = 0.5 \cdot (D - d)$$
 rounded to the nearest mm;

D as determined pursuant to paragraph 3.5.2.2.3.

Coefficient 'a' for the calculation of H_{\min} :

$$a = 0.97$$

Coefficient "b" for the calculation of H_{\max} :

$$b = 1.07$$

3.5.2.5.3. Sizes listed in Annex 6

3.5.2.5.3.1. Overall width

3.5.2.5.3.1.1. The overall width of a tyre may be less than the section width as pursuant to paragraph 3.5.2.2.1. The overall width may exceed the section width pursuant to paragraph 3.5.2.2.1 as follows:

For tyre sizes listed in Tables A6/1, A6/2 and A6/3 – by up to 4 per cent

For tyre sizes listed in Table A6/4 – by up to 8 per cent.

For tyre sizes listed in Table A6/5 – by up to 7 per cent.

The respective limits shall be rounded to the nearest millimeter (mm).

3.5.2.5.3.2. Outer diameter

3.5.2.5.3.2.1. The outer diameter of a tyre shall not be outside the range D_{min} and D_{max} obtained from the following formulae:

$$D_{min} = d + (2 \cdot H_{min})$$

$$D_{max} = d + (2 \cdot H_{max})$$

Where $H_{min} = H \cdot a$, rounded to the nearest mm

$$H_{max} = H \cdot b, \text{ rounded to the nearest mm}$$

$H = 0.5 \cdot (D - d)$ rounded to the nearest mm;

D is the outer diameter given opposite the tyre size designation in the tables of Annex 6.

d is the nominal rim diameter (mm) given opposite the tyre size designation in the tables of Annex 6.

Coefficient 'a' for the calculation of H_{min} :

$$a = 0.97$$

Coefficient "b" for the calculation of H_{max} :

For tyre sizes listed in Tables A6/1, A6/2 and A6/3:

For normal tyres, $b = 1.04$

For snow tyres the outer diameter shall not exceed the following value: $D_{max, snow} = 1.01 \cdot D_{max}$, rounded to the nearest mm, where D_{max} is the maximum outer diameter established for normal tyres above.

For special use tyres, $b = 1.06$

For tyre sizes listed in Table A6/4, $b = 1.08$

For tyre sizes listed in Table A6/5, $b = 1.07$.

- 3.6. High-speed performance test
- 3.6.1. High-speed performance test for passenger car tyres
- 3.6.1.1. Requirements
- When the tyre is tested in accordance with paragraph 3.6.1.3. or 3.6.1.5.;
- 3.6.1.1.1. There shall be no visible evidence of tread, sidewall, ply, cord, inner liner, belt or bead separation, chunking, open splices, cracking or broken cords. For tyres tested at a speed of 300 km/h (speed symbol "Y") or above, superficial blistering in the tyre tread due to localized heat build-up in the test drum is acceptable.
- 3.6.1.1.2. The tyre pressure, when measured at any time between 15 minutes and 25 minutes after the end of the test, shall not be less than 95 per cent of the initial pressure.
- 3.6.1.1.3. The outer diameter of the tyre, measured two hours after the **high-speed performance** test, shall not differ by more than ± 3.5 per cent from the outer diameter as measured before the test.

- 3.6.1.1.4. For tyres identified by means of letter code "ZR" within the size designation and suitable for speeds over 300 km/h, the above high-speed performance test is carried out on one tyre at the load and speed conditions marked on the tyre. Another high-speed performance test shall be carried out on a second sample of the same tyre type at the load and speed conditions specified as maximum by the tyre manufacturer. The second test may be carried out on the same tyre sample.
- 3.6.1.2. Preparation of the tyres with speed symbols "F" to "S" as specified in Annex 1 to this regulation.
- 3.6.1.2.1. Mount the tyre on a test rim with a width comprised between the minimum and maximum width as per Annex 9. The rim contour shall be one of those specified for the fitment of the test tyre. Inflate it to the appropriate pressure specified in the table below:

Table 4
Inflation pressure and test load

Speed symbol	Inflation pressure, kPa		Test load
	Standard load tyres, light load tyres	Extra load tyres	
F, G, J, K L, M, N, P, Q, R, S	220	260	85 % of the maximum load rating

- 3.6.1.2.2. Condition the assembly at (35 ± 3) °C for not less than three hours.
- 3.6.1.2.3. Before or after mounting the assembly on a test axle, readjust the tyre pressure to that specified in the table above in paragraph 3.6.1.2.1.
- 3.6.1.3. Test procedure for tyres with speed symbols "F", "G", "J", "K", "L", "M", "N", "P", "Q", "R" or "S" as specified in Annex 1
- 3.6.1.3.1. Press the assembly against the outer face of a test drum having a diameter of $1.7 \text{ m} \pm 1 \text{ per cent}$ or $2.0 \text{ m} \pm 1 \text{ per cent}$ and surface at least as wide as tyre tread.
- 3.6.1.3.2. Apply to the test axle a load equal to 85 per cent of the maximum load rating.
- 3.6.1.3.3. Break-in the tyre by running it for 2 hours at 80 km/h.
- 3.6.1.3.4. Allow the tyre to cool to 38 °C and readjust inflation pressure to the applicable pressure in the table in paragraph 3.6.1.2.1. above immediately before the test.
- 3.6.1.3.5. Throughout the test, the inflation pressure is not corrected, and the test load is maintained at the value applied in paragraph 3.6.1.2.1.
- 3.6.1.3.6. During the test, the ambient temperature, shall be maintained at (35 ± 3) °C. The measurement equipment for ambient temperature shall be placed in a location between 150 mm and 1,000 mm away from the test tyres.
- 3.6.1.3.7. The test is conducted, continuously and uninterrupted, for ninety minutes through three thirty-minute consecutive test stages at the following speeds: 140, 150, and 160 km/h.

- 3.6.1.3.8. Allow the tyre to cool for between 15 minutes and 25 minutes. Measure its inflation pressure. Then, deflate the tyre, remove it from the test rim, and inspect it for the conditions specified in paragraph 3.6.1.1.1. above.
- 3.6.1.4. Preparation of tyres with speed symbols "T" to "Y" as specified in Annex 1 to this Regulation.
- 3.6.1.4.1. Mount the tyre on a test rim with a width comprised between the minimum and maximum width as per Annex 9. The rim contour shall be one of those specified for the fitment of the test tyre.
- 3.6.1.4.2. Inflate it to the appropriate pressure as given (in kPa) in the table below:

Table 5

Inflation pressure and test load

<i>Speed symbol</i>	<i>Inflation pressure, kPa</i>		<i>Test load (in % of the maximum load rating)</i>
	<i>Standard load tyres, light load tyres</i>	<i>Extra load tyres</i>	
T, U, H	280	320	80 %
V	300	340	73 %
W	320	360	68 %
Y	320	360	68 %

- 3.6.1.4.3. Condition the tyre and wheel assembly at between 20 °C and 30 °C for not less than three hours.
- 3.6.1.4.4. Re-adjust the tyre pressure to that specified in paragraph 3.6.1.4.2. above.
- 3.6.1.5. Test procedure for tyres with speed symbols "T" to "Y" as specified in Annex 1 to this regulation.
- 3.6.1.5.1. Press the assembly against the outer face of 1.7 m ± 1 per cent or 2.0 m ± 1 per cent test drum.
- 3.6.1.5.2. Depending upon the speed symbol applicable to the tyre, apply a load to the test axle equal to that shown in the table in paragraph 3.6.1.4.2. above.
- 3.6.1.5.3. Throughout the test the tyre pressure shall not be corrected, and the test load shall be kept constant.
- 3.6.1.5.4. During the test the temperature in the test-room shall be maintained at between 20 °C and 30 °C or at a higher temperature if the manufacturer desires to increase test severity.
- 3.6.1.5.5. Carry the test through, without interruptions as follows, in relation to the tyre's speed symbol.
- 3.6.1.5.6. The initial test speed (ITS) is equal to the tyre's speed symbol:
- Less 40 km/h on a 1.7 m ± 1 per cent drum, or
 - Less 30 km/h on a 2.0 m ± 1 per cent drum.
- 3.6.1.6. For tyres of speed symbols "T" to "W" as specified in Annex 1;
- 3.6.1.6.1. Accelerate the equipment at a constant rate such that the initial test speed (ITS) is reached at the end of 10 minutes from start-up.

- (a) Then, at the ITS for 10 minutes;
 - (b) Then, at the ITS plus 10 km/h for 10 minutes;
 - (c) Then, at the ITS plus 20 km/h for 10 minutes;
 - (d) Then, at the ITS plus 30 km/h for 20 minutes.
- 3.6.1.6.2. For tyres of speed symbol "Y": Accelerate the equipment at a constant rate such that the Initial Test Speed (ITS) is reached at the end of 10 minutes from start-up.
- (a) Then, at the ITS for 20 minutes;
 - (b) Then, at the ITS plus 10 km/h for 10 minutes.
 - (c) Then, at the ITS plus 20 km/h for 10 minutes;
 - (d) Then, at the ITS plus 30 km/h for 10 minutes.
- 3.6.1.7. For tyres with "ZR" in the size designation intended for use at speeds greater than 300 km/h;
- 3.6.1.7.1. Test the tyre at the load and inflation for a speed symbol "Y" tyre according to the procedures specified above in paragraphs 3.6.1.4.2. and 3.6.1.6.2. above.
- 3.6.1.7.2. Test a further sample of the same type according to:
- Inflate the tyre to 320 kPa for standard load or light load tyres and 360 kPa for extra load tyres. Apply a load to the test axle that is equal to 80 per cent of the **maximum load rating** specified by the tyre manufacturer. Accelerate the equipment at a constant rate such that the rated speed of the tyre is reached at the end of 10 minutes from the start-up. Then test at the rated speed for 5 minutes.

3.6.2. High-speed performance test for LT/C tyres

3.6.2.1. High-speed performance test for LT/C tyres with speed symbol < "Q"

3.6.2.1.1. Requirements

3.6.2.1.1.1. When the tyre is tested in accordance with paragraph 3.6.2.1.3.:

- (a) There shall be no visual evidence of tread, sidewall, ply, cord, inner liner, belt or bead separation, chunking, open splices, cracking, or broken cords.
- (b) The tyre pressure, when measured at any time between 15 minutes and 25 minutes after the end of the test, shall not be less than 95 per cent of the initial pressure specified in paragraph 3.6.2.1.2.1.

3.6.2.1.2. Preparation of tyre

3.6.2.1.2.1. Mount the tyre on a test rim with a width comprised between the minimum and maximum width as per Annex 9. The rim contour shall be one of those specified for the fitment of the test tyre and inflate it to the pressure specified for the tyre in the following table:

Table 6

Test Inflation Pressure Selection Table for High-Speed Performance test

Reference Test Inflation Pressure Range (kPa)	Test Inflation Pressure (kPa) for Nominal section width	
	≤ 295	> 295
170 – 199	n/a	n/a
200 – 299	n/a	230
300 – 399	320	320
400 – 499	410	410
500 – 599	500	n/a

3.6.2.1.2.2. Condition the assembly at (35 ± 3) °C for not less than 3 hours.

3.6.2.1.2.3. Before or after mounting the assembly on a test axle, readjust the tyre pressure to that specified in paragraph 3.6.2.1.2.1.

3.6.2.1.3. Test procedure

3.6.2.1.3.1. Press the assembly against the outer face of a test drum with a diameter of 1.7 m \pm 1 per cent and surface at least as wide as tyre tread.

3.6.2.1.3.2. Apply to the test axle a load equal to 85 per cent of the maximum load rating.

3.6.2.1.3.3. Break-in the tyre by running it for 2 hours at 80 km/h.

3.6.2.1.3.4. Allow tyre to cool to 38 °C and readjust inflation pressure to applicable pressure in paragraph 3.6.2.1.2.1. immediately before the test.

3.6.2.1.3.5. Throughout the test, the inflation pressure is not corrected, and the test load is maintained at the value applied in paragraph 3.6.2.1.2.1.

3.6.2.1.3.6. During the test, the ambient temperature, is maintained at (35 ± 3) °C. The measurement equipment for ambient temperature shall be placed in a location between 150 mm and 1,000 mm away from the test tyres.

3.6.2.1.3.7. The test is conducted, continuously and uninterrupted, for ninety minutes through three thirty-minute consecutive test stages at the following speeds: 140, 150, and 160 km/h.

3.6.2.1.3.8. Allow the tyre to cool for between 15 minutes and 25 minutes. Measure its inflation pressure. Then, deflate the tyre, remove it from the test rim, and inspect it for the conditions specified in paragraph 3.6.2.1.1.1., subparagraph (a).

3.6.2.2. High speed performance test for LT/C tyres with speed symbol \geq "Q"

3.6.2.2.1. Requirements

3.6.2.2.1.1. When the tyre is tested in accordance with paragraph 3.6.2.2.3.:

(a) There shall be no visual evidence of any tread separation, ply separation, cord separation, chunking or broken cords.

(b) The outer diameter of the tyre, measured six hours after the test, shall not differ by more than ± 3.5 per cent from the outer diameter as measured before the test.

- 3.6.2.2.1.2. If the load/speed combination for the tyre is given in the table in Annex 5 "Variation of load capacity with speed for LT/C tyres", the test prescribed in paragraph 3.6.2.2. need not be carried out for load and speed values other than the nominal values.
- 3.6.2.2.1.3. In the case of a tyre which has an alternative Service Description in addition to the one that is subject to the variation of load with speed given in the table in Annex 5 to this Regulation, the test prescribed in paragraph 3.6.2.2. shall also be carried out on a second tyre of the same type at the additional load/speed combination, unless a sufficient engineering justification is provided by the tyre manufacturer for a worst-case combination of load index and speed category symbol, to be tested.
- 3.6.2.2.2. Preparation of tyre
 - 3.6.2.2.2.1. Mount the tyre on a test rim with a width comprised between the minimum and maximum width as per Annex 9. The rim contour shall be one of those specified for the fitment of the test tyre.
 - 3.6.2.2.2.2. Use a new inner tube or combination of inner tube, valve and flap (as required) when testing tyres with inner tubes.
 - 3.6.2.2.2.3. Inflate the tyre to the Reference Test Inflation Pressure.
 - 3.6.2.2.2.4. Condition the tyre-and-wheel assembly at test-room temperature as specified in paragraph 3.6.2.2.3.4. for not less than three hours.
 - 3.6.2.2.2.5. Readjust the tyre pressure to that specified in paragraph 3.6.2.2.2.3. above.
- 3.6.2.2.3. Test procedure
 - 3.6.2.2.3.1. Mount the tyre-and-wheel assembly on the test axle and press it against the outer face of a smooth power-driven test drum $1.7\text{ m} \pm 1\text{ per cent}$ or $2.0\text{m} \pm 1\text{ per cent}$ in diameter having a surface at least as wide as the tyre tread.
 - 3.6.2.2.3.2. Apply to the test axle a test load as specified in paragraph 3.6.2.2.4.
 - 3.6.2.2.3.3. The tyre pressure shall not be corrected throughout the test and the test load shall be kept constant throughout each of the three test stages.
 - 3.6.2.2.3.4. During the test the ambient temperature in the test-room shall be maintained in the range specified in the following table:

Table 7
Test-room temperature

Speed Symbol	Temperature t (°C)
Q, R	35 ± 3
S, T, H	25 ± 5 (*)

(*) or higher if the tyre manufacturer agrees

- The measurement equipment for ambient temperature shall be placed in a location between 150 mm and 1,000 mm away from the test tyres.
- 3.6.2.2.3.5. The test programme shall be carried out without interruption.
- 3.6.2.2.4. Load placed on the wheel as a percentage of the maximum load rating in single application:

3.6.2.2.4.1. 90 per cent when tested on a test drum 1.7 m \pm 1 per cent in diameter;

3.6.2.2.4.2. 92 per cent when tested on a test drum 2.0 m \pm 1 per cent in diameter.

3.6.2.2.5. Initial test speed: speed corresponding to the speed symbol less 20 km/h;

3.6.2.2.5.1. Time to reach the initial test speed: 10 min.

3.6.2.2.5.2. Duration of the first step = 10 min.

3.6.2.2.6. Second test speed: speed corresponding to the speed symbol less 10 km/h;

3.6.2.2.6.1. Duration of the second step = 10 min.

3.6.2.2.7. Final test speed: speed corresponding to the speed symbol:

3.6.2.2.7.1. Duration of the final step = 30 min.

3.7. Strength test

3.7.1. Strength test for passenger car tyres

3.7.1.1. Each tyre shall meet the requirements for minimum breaking energy as calculated in 3.7.1.2.6. specified in the table below.

Table 8
Minimum breaking energy

Nominal section width	Units	Standard load or light load tyres	Extra load tyres
Below 160 mm	Joules	220	441
	Inch-pounds	1950	3900
160 mm or above	Joules	294	588
	Inch-pounds	2600	5200

3.7.1.2. Strength test procedure

3.7.1.2.1. Mount the tyre on a test rim with a width comprised between the minimum and maximum width as per Annex 9. The rim contour shall be one of those specified for the fitment of the test tyre. Inflate it to the test inflation pressure specified in the table below:

Table 9
Strength test tyre inflation pressures for strength test

Tyre application	Test Inflation pressure (kPa)
Standard load, light load	180
Extra load	220

3.7.1.2.2. Condition the wheel and tyre assembly for at least three hours at the temperature of the test room;

3.7.1.2.3. Re-adjust the tyre pressure to that specified in the previous table above (paragraph 3.7.1.2.1);

3.7.1.2.4. Force a (19 ± 0.5) mm ((0.75 ± 0.02) inch) diameter cylindrical steel plunger with a hemispherical end perpendicularly into the tread rib as near to the centreline as possible, avoiding penetration into the tread pattern groove, at the rate of (50 ± 2.5) mm/min ((2 ± 0.1) in/min).

3.7.1.2.5. Record the force and penetration at five test points equally spaced around the circumference of the tyre.

If the tyre fails to break before the plunger is stopped by reaching the rim, record the force and penetration as the rim is reached and use these values in paragraph 3.7.1.2.6

If the tyre fails to break before the plunger is stopped on reaching the rim, and the required minimum breaking energy is not achieved, then record the bottom out and the corresponding energy, the test results are inconclusive and Contracting Parties may provide further guidance to manufacturers.

3.7.1.2.6. The breaking energy, W, in joules, shall be calculated from:

$$W = ((F \cdot P)/2) \cdot 10^{-3}$$

Where:

W = Energy in joules

F = Force in newtons applied to the plunger

P = Penetration of the plunger in millimeters

or

$$W = (F \cdot P)/2$$

Where:

W = Energy in inch-pounds

F = Force in pounds and

P = Penetration in inches.

3.7.1.2.7. Determine the breaking energy value for the tyre by computing the average of the five values obtained;

3.7.1.2.8. In the case of tubeless tyres, an inner tube may be provided to ensure the retention of the inflation pressure throughout the test provided that such inner tube does not adversely affect the test.

3.7.2. Strength test for LT/C tyres

3.7.2.1. Requirements

When tested according to the procedure described in this section, LT/C tyres shall have an average strength as calculated in 3.7.2.3.3 of not less than the values shown in the table below:

Table 10
Minimum Strength

Reference Test Inflation Pressure Range (kPa)	Rim Diameter Codes > 13 Tubeless Rim Diameter Codes > 15 Tube Type		Rim Diameter Codes < 12 Tubeless and Tube Type	Rim Diameter Codes 13 and 14 Tube Type
	Nominal Section Width			
	≤ 295 mm	> 295 mm		
170 – 199	n/a	294	68	n/a
200 – 299	294	362	136	192
300 – 399	362	514	203	271
400 – 499	514	576	271	384
500 – 599	576	n/a	339	514

3.7.2.2. Preparation of tyre

Mount the tyre on a rim with a width comprised between the minimum and maximum width as per Annex 9. The rim contour shall be one of those specified for the fitment of the test tyre.

Inflate it to the Reference Test Inflation Pressure.

If the tyre is tubeless, a tube may be inserted to prevent loss of air during the test in the event of puncture

Condition it at ambient room temperature for at least 3 hours and readjust the inflation pressure if necessary.

3.7.2.3. Test procedure

3.7.2.3.1. Force a (19 ± 0.5) mm ((0.75 ± 0.02) inch) diameter cylindrical steel plunger with a hemispherical end perpendicularly into the tread rib as near to the centreline as possible, avoiding penetration into the tread pattern groove, at the rate of (50 ± 2.5) mm/min ((2 ± 0.1) in/min).

3.7.2.3.2. Record the force and penetration at five test points equally spaced around the circumference of the tyre.

If the tyre fails to break before the plunger is stopped by reaching the rim, record the force and penetration as the rim is reached and use these values in paragraph 3.7.2.3.3.

If the tyre fails to break before the plunger is stopped on reaching the rim, and the required minimum breaking energy is not achieved, then record the bottom out and the corresponding energy, the test results are inconclusive and Contracting Parties may provide further guidance to manufacturers.

3.7.2.3.3. Compute the breaking energy for each test point by means the following formula:

$$W = ((F \cdot P)/2) \cdot 10^{-3}$$

Where:

W = Energy, in joules;

F = Force, in newtons; and

P = Penetration, in millimeters;

- 3.7.2.3.4. Determine the breaking energy value for the tyre by computing the average of the five values obtained in accordance with paragraph 3.7.2.3.3.
- 3.8. Bead unseating resistance test
- 3.8.1. Bead unseating resistance test for tubeless passenger car tyres
- 3.8.1.1. Requirements
- 3.8.1.1.1. Each tubeless tyre shall meet the requirements for minimum force, in newtons, for bead unseating resistance, specified in one of the tables below.
- 3.8.1.1.2. For tubeless radial ply tyres the applied force required to unseat the tyre bead at the point of contact, in relation to the nominal section width of the tyre, shall not be less than:

Table 11

Minimum bead unseating force (Metric tyre sizes)

<i>Nominal section width (mm)</i>	<i>Minimum force (N)</i>
Less than 160	6 670
From 160 to 204	8 890
Equal to or greater than 205	11 120

Table 12

Minimum bead unseating force (Other tyre sizes)

<i>Nominal section width (code)</i>	<i>Minimum force (N)</i>
Less than 6.00	6 670
From 6.00 to 7.99	8 890
Equal to or greater than 8.00	11 120

- 3.8.1.2. Preparation of tyre
- 3.8.1.2.1. Wash the tyre and dry it at the beads. Mount it without lubricant or adhesive on a clean, painted test rim with a width comprised between the minimum and maximum width as per Annex 9. The rim contour shall be one of those specified for the fitment of the test tyre.
- 3.8.1.2.2. Inflate the tyre to the pressure specified in the table shown below:

Table 13

Test inflation pressures for Bead unseating resistance test

<i>Tyre application</i>	<i>Test inflation pressure kPa</i>
Standard load, light load	180
Extra load	220

- 3.8.1.3. Test procedure
- 3.8.1.3.1. Mount the assembly on a fixture as shown in Figure 2, below, and force the bead unseating block shown in Figure 3 or Figure 4 against the tyre sidewall as required by the geometry of the fixture.
- 3.8.1.3.2. Position the bead unseating block against the tyre sidewall at a horizontal distance "A" as shown in Figure 2 and Table 14, below.
- 3.8.1.3.3. Apply a force through the block to the tyre outer sidewall at a rate of (50 ± 2.5) mm/min ((2 ± 0.1) inches/min).
- 3.8.1.3.4. Increase the force until the bead unseats or until the prescribed value shown in paragraph 3.8.1.1.2. is reached.
- 3.8.1.3.5. Repeat the test at least four times at places approximately equally spaced around the tyre circumference.

Figure 2

Bead unseating fixture

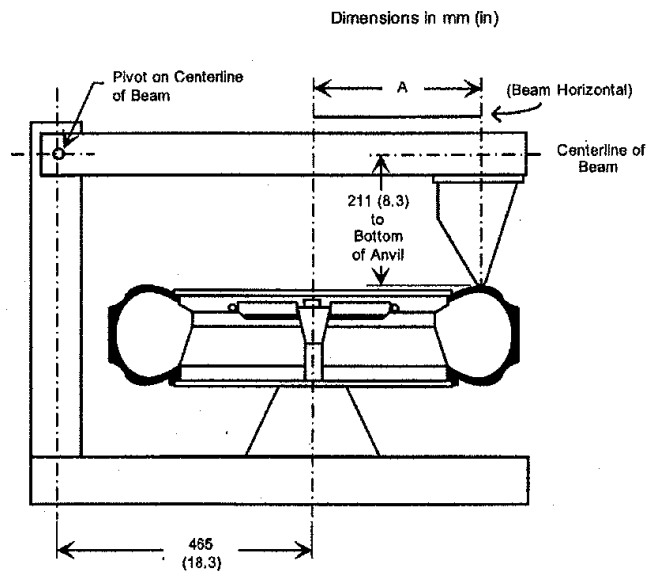

Table 14
List of "A" dimensions

<i>Table of A dimension for different rim codes</i>		
<i>Rim code</i>	<i>mm</i>	<i>Inches</i>
20	345	13.50
19	330	13.00
18	318	12.50
17	305	12.00
16	292	11.50
15	279	11.00

<i>Table of A dimension for different rim codes</i>		
<i>Rim code</i>	<i>mm</i>	<i>Inches</i>
14	267	10.50
13	254	10.00
12	241	9.50
11	229	9.00
10	216	8.50
320	216	8.50
340	229	9.00
345	235	9.25
365	248	9.75
370	254	10.00
390	279	11.00
415	292	11.50

Figure 3

Bead unseating block

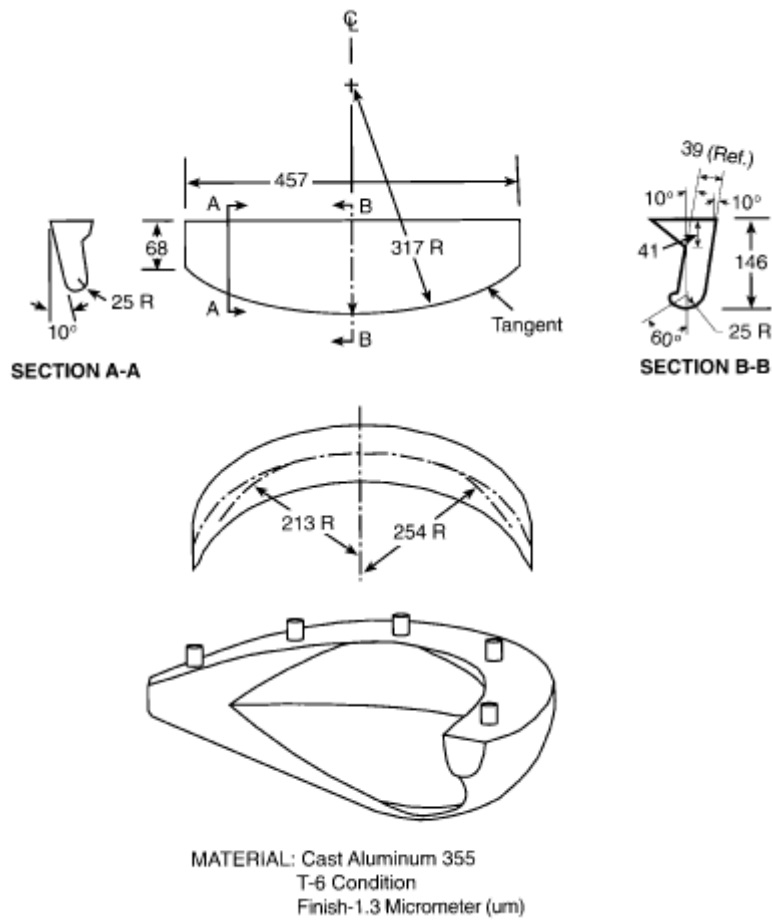
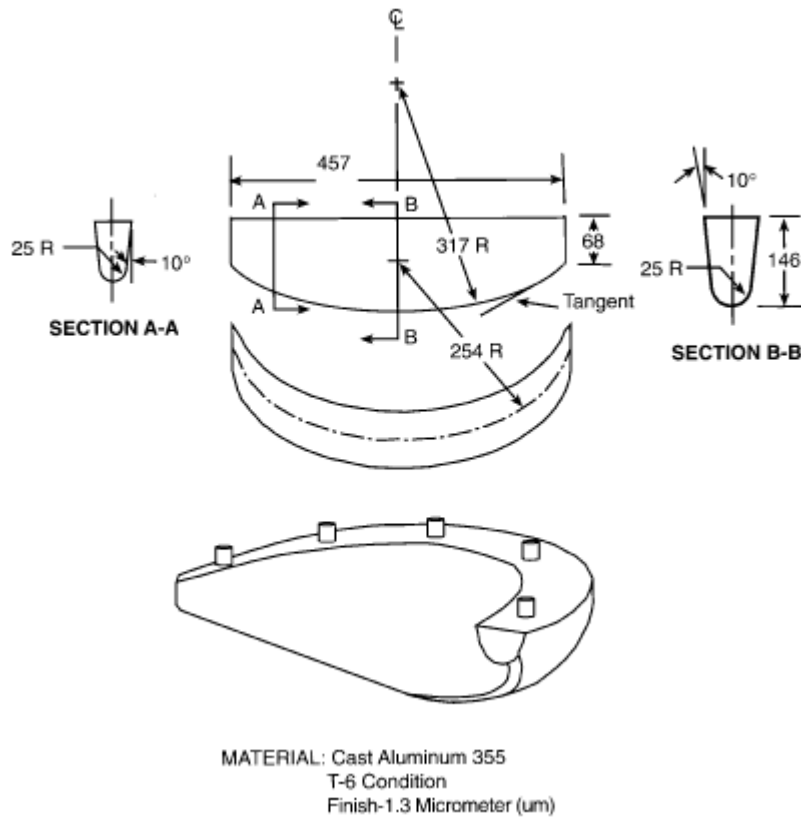

Figure 4

Bead unseating block

3.8.2. Bead unseating resistance test for LT/C tubeless tyres with rim codes of 10 or greater

3.8.2.1. Requirements

When a tubeless LT/C tyre is tested in accordance with the procedure described in this section, the applied force required to unseat the tyre bead at the point of contact shall be not less than:

- (a) 6670 N (1500 pounds) for tyres with a nominal section width of less than 160 mm (6 inches);
- (b) 8890 N (2000 pounds) for tyres with a nominal section width of 160 mm (6 inches) or more but less than 205 mm (8 inches);
- (c) 11120 N (2500 pounds) for tyres with a nominal section width of 205 mm (8 inches) or more.

3.8.2.2. Preparation of tyre-wheel assembly

3.8.2.2.1. Wash the tyre, dry it at the beads, and mount it without lubrication or adhesives on a clean, painted test rim with a width comprised between the minimum and maximum width as per Annex 9. The rim contour shall be one of those specified for the fitment of the test tyre.

3.8.2.2.2. Inflate it to the applicable pressure specified in the following table at ambient room temperature:

For LT/C tyres, the test inflation pressure to be used for the bead unseating test is as follows:

Table 15

Test Inflation Pressure for bead unseating resistance test

Reference Test Inflation Pressure Range (kPa)	Test Inflation pressure for Bead Unseating (kPa)
170 – 199	n/a
200 – 299	190
300 – 399	260
400 – 499	340
500 – 599	410

3.8.2.2.3. Mount the wheel and tyre in a fixture shown in Figure 7 and force the bead unseating block shown in Figure 8 or Figure 9 against the tyre sidewall as required by the geometry of the fixture.

Figure 7

Bead Unseating Fixture (all dimension in mm) and table of "A" dimensions

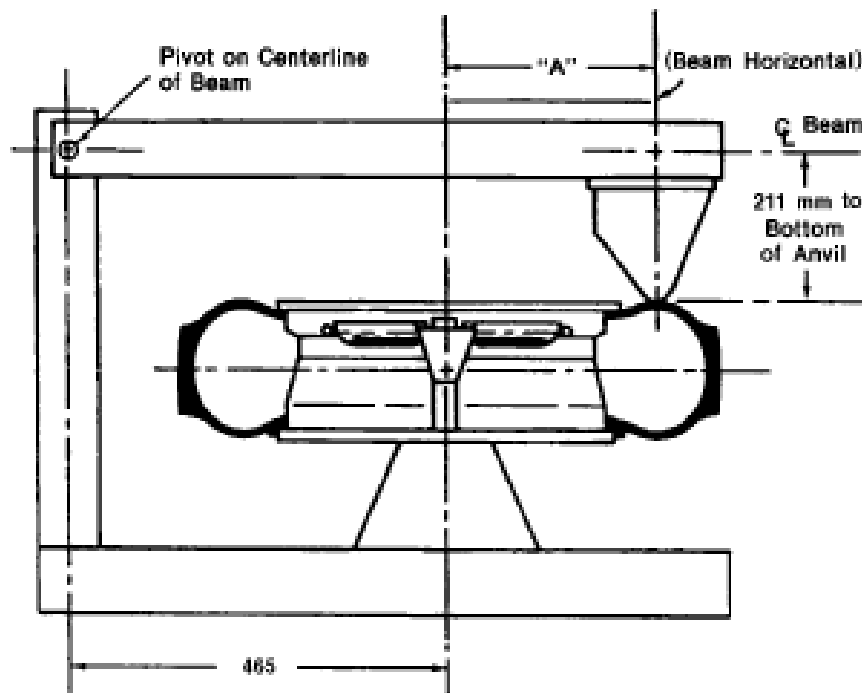

Table 16

'A' dimensions

<i>Table of A dimension for different rim codes</i>		
<i>Rim code</i>	<i>mm</i>	<i>Inches</i>
20	345	13.50
19	330	13.00
18	318	12.50
17	305	12.00
16	292	11.50
15	279	11.00
14	267	10.50
13	254	10.00
12	241	9.50
11	229	9.00
10	216	8.50
320	216	8.50
340	229	9.00
345	235	9.25
365	248	9.75
370	254	10.00
390	279	11.00
415	292	11.50

Figure 8

Diagram of bead unseating block (all dimensions in mm)

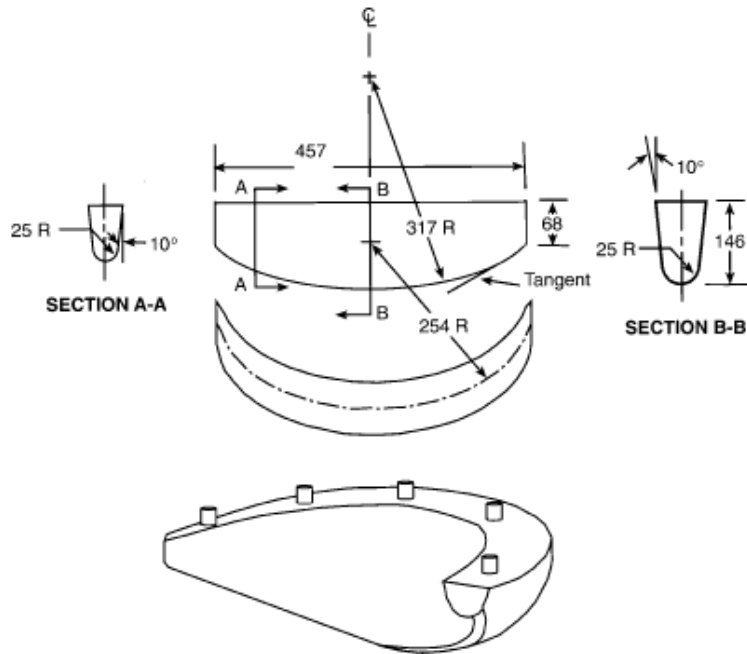

MATERIAL: Cast Aluminum 355
T-6 Condition
Finish-1.3 Micrometer (um)

Figure 9

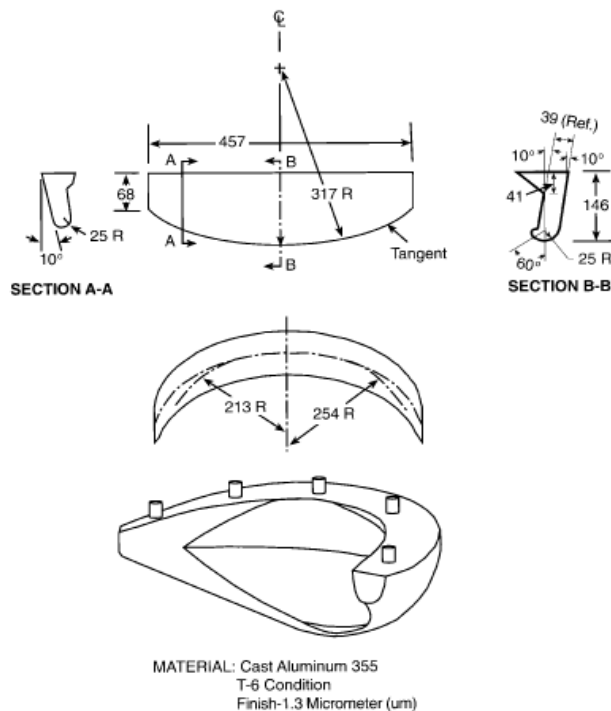
Diagram of bead unseating block (all dimensions in mm)

3.8.2.3. Test procedure

3.8.2.3.1. Apply a load through the block to the tyre's outer sidewall at the distance specified in Figure 8 for the applicable wheel size at a rate (50 ± 2.5) mm/min ((2 ± 0.1) inches/min), with the load arm substantially parallel to the tyre and rim assembly at the time of engagement.

3.8.2.3.2. Increase the load until the bead unseats or the applicable value specified in paragraph 3.8.2.1. is reached.

3.8.2.3.3. Repeat the test at least four places equally spaced around the tyre circumference.

3.9. Endurance test

3.9.1. **Harmonized** endurance and low inflation pressure performance test for passenger car tyres

3.9.1.1. Endurance test for passenger car tyres

3.9.1.1.1. Requirements

3.9.1.1.1.1. The following requirements shall be met by all passenger car tyres when tested in accordance with the procedures described in paragraphs 3.9.1.1.2. and 3.9.1.1.3. below.

3.9.1.1.1.2. There shall be no visible evidence of tread, sidewall, ply, cord, inner liner, belt or bead separation, chunking, open splices, cracking or broken cords.

3.9.1.1.1.3. The tyre pressure, when measured at any time between 15 minutes and 25 minutes after the end of the test, shall not be less than 95 per cent of the initial pressure specified in paragraph 3.9.1.1.2.

3.9.1.1.2. Preparation of tyre

Mount the tyre on a test rim with a width comprised between the minimum and maximum width as per Annex 9. The rim contour shall be one of those specified for the fitment of the test tyre.

Inflate the tyre to the pressure specified in the table below.

Table 17

Test inflation pressures for Endurance test

<i>Tyre application</i>	<i>Test Inflation pressure (kPa)</i>
Standard load, light load	180
Extra load	220

3.9.1.1.2.1. Condition the assembly at (35 ± 3) °C for not less than 3 hours.

3.9.1.1.2.2. Readjust the pressure to the value specified in the table in paragraph 3.9.1.1.2. immediately before testing.

3.9.1.1.3. Test procedure

3.9.1.1.3.1. Mount the assembly on a test axle and apply a load as given in paragraph 3.9.1.1.3.3. below to load it against the outer face of a smooth wheel having a diameter of $1.7 \text{ m} \pm 1$ per cent

3.9.1.1.3.2. During the test the ambient temperature, at a distance of not less than 150 mm and not more than 1 m from the tyre, is maintained at (35 ± 3) °C

3.9.1.1.3.3. Conduct the test, without interruptions, at not less than 120 km/h (110 km/h for snow tyres for use in severe snow conditions and marked with the three peak mountain snowflake) test speed with loads and test periods not less than those shown in the table below:

Table 18

Test programme for endurance test of passenger car tyres:

<i>Test period</i>	<i>Duration</i>	<i>Load as a percentage of the maximum load rating</i>
1	4 h	85 %
2	6 h	90 %
3	24 h	100 %

3.9.1.1.3.4. Throughout the test the inflation pressure shall not be corrected, and the test loads shall be kept constant at the value corresponding to each test period.

- 3.9.1.1.3.5. Allow the tyre to cool for between 15 and 25 minutes, then measure its inflation pressure. Inspect the tyre externally on the test rim for the conditions specified in paragraph 3.9.1.1.1., 3.9.1.1.2., and 3.9.1.1.3. above.
- 3.9.1.2. Low inflation pressure performance test for passenger car tyres
- 3.9.1.2.1. Requirements
- The following requirements shall be met by tyres when tested in accordance with the procedure given in paragraph 3.9.1.2.3. below.
- 3.9.1.2.1.1. There shall be no visible evidence of tread, sidewall, ply, cord, inner liner, belt or bead separation, chunking, open splices, cracking or broken cords.
- 3.9.1.2.1.2. The tyre pressure, when measured at any time between 15 minutes and 25 minutes after the end of the test, shall not be less than 95 per cent of the initial pressure specified in paragraph 3.9.1.2.2. below.
- 3.9.1.2.2. Preparation of tyre
- This test is conducted following completion of the tyre endurance test using the same tyre and rim assembly tested in accordance with paragraph 3.9.1.1 above, with the tyre deflated to the following pressures show in the table below:

Table 19

Test inflation pressure for low inflation pressure performance test of passenger car tyres

<i>Tyre application</i>	<i>Test inflation pressure kPa</i>
Standard load, light load	140
Extra load	160

- 3.9.1.2.2.1. After the tyre is deflated to the appropriate test inflation pressure in paragraph 3.9.1.2.2. at the completion of the endurance test, condition the assembly at (35 ± 3) °C for not less than 2 hours.
- 3.9.1.2.2.2. Before or after mounting the assembly on a test axle, readjust the tyre pressure to that specified in the table in paragraph 3.9.1.2.2.
- 3.9.1.2.3. Test procedure
- 3.9.1.2.3.1. The test is conducted for ninety minutes at the end of the test specified in paragraph 3.9.1.1, continuous and uninterrupted, at a speed of 120 km/h (110 km/h for snow tyres for use in severe snow conditions and marked with the three peak mountain snowflake).
- 3.9.1.2.3.2. Press the assembly against the outer face of a test drum having a diameter of $1.7m \pm 1$ per cent
- 3.9.1.2.3.3. Apply to the test axle a load equal to 100 per cent of the maximum load rating.
- 3.9.1.2.3.4. Throughout the test, the inflation pressure is not corrected, and the test load is maintained at the initial level.

- 3.9.1.2.3.5. During the test, the ambient temperature, is maintained at (35 ± 3) °C. The measurement equipment for ambient temperature shall be placed in a location between 150 mm and 1,000 mm away from the test tyres.
- 3.9.1.2.3.6. Allow the tyre to cool for between 15 and 25 minutes. Measure its inflation pressure. Then deflate the tyre, remove it from the test rim, and inspect it for the conditions specified in paragraph 3.9.1.2.1.1. above.
- 3.9.2. Non-harmonized endurance tests for LT/C tyres
- This section is reserved for a future harmonized endurance test. It currently contains two non-harmonized endurance tests. When transposing the provisions of this Regulation to the national/regional legislation, Contracting Parties wishing to include this kind of test are encouraged to review the sub sections 3.9.2.1. and 3.9.2.2. based on the provisions of FMVSS 139 and UN Regulation No. 54 respectively.
- The endurance test represented in paragraph 3.9.2.1. is applicable for all LT/C tyres regardless of speed category symbol and consists of two tests: the endurance test described in paragraph 3.9.2.1.1. and the Low inflation pressure performance test described in paragraph 3.9.2.1.2. which shall be performed in sequence. The low inflation pressure performance test is conducted following completion of the tyre endurance test using the same tyre and rim assembly.
- The endurance test represented in paragraph 3.9.2.2. is only applicable for LT/C tyres with Speed Symbol less than "Q".
- 3.9.2.1. Endurance and Low inflation pressure performance test for LT/C tyres¹⁵
- 3.9.2.1.1. Endurance test for LT/C tyres
- 3.9.2.1.1.1. Requirements
- 3.9.2.1.1.1.1. When the tyre is tested in accordance with paragraph 3.9.2.1.1.3.:
- (a) There shall be no visual evidence of tread, sidewall, ply, cord, belt or bead separation, chunking, open splices, cracking or broken cords.
 - (b) The tyre pressure, when measured at any time between 15 minutes and 25 minutes after the end of the test, shall not be less than 95 per cent of the initial pressure specified in paragraph 3.9.2.1.1.2.1.
- 3.9.2.1.1.2. Preparation of tyre
- 3.9.2.1.1.2.1. Mount the tyre on a test rim with a width comprised between the minimum and maximum width as per Annex 9. The rim contour shall be one of those specified for the fitment of the test tyre and inflate it to the pressure specified for the tyre in the following table:

¹⁵ From FMVSS 139

Table 20

Test inflation pressure for Endurance test

Reference Test Inflation Pressure Range (kPa)	Test Inflation Pressure (kPa) for Nominal section width	
	≤ 295 mm	> 295 mm
170 – 199	n/a	n/a
200 – 299	n/a	190
300 – 399	260	260
400 – 499	340	340
500 – 599	410	n/a

3.9.2.1.1.2.1.1. For the inflation device, the maximum range shall be equal or higher than 100kPa and precision shall be ±10kPa.

3.9.2.1.1.2.2. Condition the assembly at (35 ± 3) °C for not less than 3 hours.

3.9.2.1.1.2.3. Readjust the pressure to the value specified in paragraph 3.9.2.1.1.2.1. immediately before testing.

3.9.2.1.1.3. Test procedure

3.9.2.1.1.3.1. Mount the assembly on a test axle and press it against the outer face of a smooth wheel having a diameter of $1.7 \text{ m} \pm 1$ per cent.

3.9.2.1.1.3.2. During the test, the ambient temperature, at a distance of not less than 150 mm and not more than 1 m from the tyre, is maintained at (35 ± 3) °C.

3.9.2.1.1.3.3. Conduct the test, without interruptions, at the test speed of not less than 120 km/h with loads and test periods not less than those shown in the following table. For snow tyres for use in severe snow conditions and marked with the three-peaked mountain-snowflake symbol, conduct the test at not less than 110 km/h.

Table 21

Load programme for Endurance test

Test period	Duration (hours)	Load as a percentage of the maximum load rating
1	4	85
2	6	90
3	24	100

3.9.2.1.1.3.4. Throughout the test, the inflation pressure is not corrected, and the test loads are maintained at the value corresponding to each test period, as shown in the table in paragraph 3.9.2.1.1.3.3.

3.9.2.1.1.3.5. Allow the tyre to cool for between 15 minutes and 25 minutes after running the tyre for the time specified in the table in paragraph 3.9.2.1.1.3.3., measure its inflation pressure. Inspect the tyre externally on the test rim for the conditions specified in paragraph 3.9.2.1.1.1.1.

- 3.9.2.1.2. Low inflation pressure performance test for LT/C tyres
 - 3.9.2.1.2.1. Requirements
 - 3.9.2.1.2.1.1. When the tyre is tested in accordance with paragraph 3.9.2.1.2.3.:
 - (a) There shall be no visual evidence of tread, sidewall, ply, cord, inner liner, belt or bead separation, chunking, open splices, cracking, or broken cords, and;
 - (b) The tyre pressure, when measured at any time between 15 minutes and 25 minutes after the end of the test, shall not be less than 95 per cent of the initial pressure specified in paragraph 3.9.2.1.2.2.1.
 - 3.9.2.1.2.2. Preparation of tyre

3.9.2.1.2.2.1. This test is conducted following completion of the tyre endurance test using the same tyre and rim assembly tested in accordance with paragraph 3.9.2.1.1. with the tyre deflated to the following appropriate pressure:

Table 22

Test Inflation pressure for Low inflation pressure performance test

Reference Test Inflation Pressure (kPa)	Test Inflation Pressure (kPa)
200 – 299	150
300 – 399	200
400 – 499	260
500 – 599	320

3.9.2.1.2.2.1.1. For the inflation device, the maximum range shall be equal or higher than 100 kPa and precision shall be ± 10 kPa.

- 3.9.2.1.2.2.2. After the tyre is deflated to the appropriate test inflation pressure in paragraph 3.9.2.1.2.2.1. at the completion of the endurance test, condition the assembly at (35 ± 3) °C for not less than 2 hours.
- 3.9.2.1.2.2.3. Before or after mounting the assembly on a test axle, readjust the tyre pressure to that specified in paragraph 3.9.2.1.2.2.1.
- 3.9.2.1.2.3. Test procedure
 - 3.9.2.1.2.3.1. The test is conducted for ninety minutes at the end of the test specified in paragraph 3.9.2.1.1., continuous and uninterrupted, at a speed of 120 km/h. For snow tyres for use in severe snow conditions and marked with the three-peaked mountain-snowflake symbol, conduct the test at not less than 110 km/h.
 - 3.9.2.1.2.3.2. Press the assembly against the outer face of a test drum with a diameter of 1.7 m \pm 1 per cent and surface at least as wide as tyre tread.
 - 3.9.2.1.2.3.3. Apply to the test axle a load equal to 100 per cent of the maximum load rating.
 - 3.9.2.1.2.3.4. Throughout the test, the inflation pressure is not corrected, and the test load is maintained at the initial level.
 - 3.9.2.1.2.3.5. During the test, the ambient temperature, is maintained at (35 ± 3) °C.

The measurement equipment for ambient temperature shall be placed in a location between 150 mm and 1,000 mm away from the test tyres.

- 3.9.2.1.2.3.6. Allow the tyre to cool for between 15 minutes and 25 minutes. Measure its inflation pressure. Then, deflate the tyre, remove it from the test rim, and inspect it for the conditions specified in paragraph 3.9.2.1.2.1.1., subparagraph (a).
- 3.9.2.2. Endurance test for LT/C tyres ¹⁶
- 3.9.2.2.1. Requirements
- 3.9.2.2.1.1. An LT/C tyre which, after undergoing the endurance test, does not exhibit any tread separation, ply separation, cord separation, chunking or broken cords shall be deemed to have passed the test.
- 3.9.2.2.1.2. In the case of a tyre which has an alternative Service Description in addition to the one that is subject to the variation of load with speed given in the table in Annex 5 to this Regulation, the endurance shall also be carried out on a second tyre of the same type at the additional load/speed combination.
- 3.9.2.2.2. Preparing the tyre
- 3.9.2.2.2.1. Mount the tyre on a rim with a width comprised between the minimum and maximum width as per Annex 9. The rim contour shall be one of those specified for the fitment of the test tyre.
- 3.9.2.2.2.2. Use a new inner tube or combination of inner tube, valve and flap (as required) when testing tyres with inner tubes.
- 3.9.2.2.2.3. Inflate the tyre to the Reference Test Inflation Pressure.
- 3.9.2.2.2.4. Condition the tyre-and-wheel assembly at test-room temperature for not less than three hours.
- 3.9.2.2.2.5. Readjust the tyre pressure to that specified in paragraph 3.9.2.2.2.3. above.
- 3.9.2.2.3. Test procedure
- 3.9.2.2.3.1. Mount the tyre-and-wheel assembly on the test axle and press it against the outer face of a smooth power-driven test drum 1.7 m ± 1 per cent in diameter having a surface at least as wide as the tyre tread.
- 3.9.2.2.3.2. Apply to the test axle a series of test loads as defined in paragraph 3.9.2.2.4. where the maximum load rating will be the one corresponding to tyre single application.
- 3.9.2.2.3.3. The endurance test programme is shown in paragraph 3.9.2.2.4.
- 3.9.2.2.3.4. The tyre pressure shall not be corrected throughout the test and the test load shall be kept constant throughout each of the three test stages.
- 3.9.2.2.3.5. During the test the temperature in the test-room shall be maintained at between 20 °C and 30 °C or at a higher temperature if the manufacturer so agrees.
- 3.9.2.2.3.6. The endurance-test programme shall be carried out without interruption.

¹⁶ From UN Regulation No 54

3.9.2.2.4. Endurance test programme

Table 23
Endurance test programme

Load index	Tyre speed category symbol	Test-drum speed Radial-ply km/h	Load placed on the wheel as a percentage of the maximum load rating		
			7 h	16 h	24 h
122 or more	F	32	66 %	84 %	101 %
	G	40			
	J	48			
	K	56			
	L	64			
	M	72			
121 or less	F	32	70 %	88 %	106 %
	G	40			
	J	48			
	K	56			
	L	64	4 h	6 h	
	M	80	75 %	97 %	114 %
	N	88	75 %	97 %	114 %
	P	96	75 %	97 %	114 %

Special use tyres (marked "ET" or "ML" or "MPT") should be tested at a speed equal to 85 per cent of the speed prescribed for equivalent normal tyres.

3.10. Flat tyre running mode test

3.10.1. Flat tyre running mode test for passenger car tyres

For run flat tyres identified by means of letter code "RF" within the size designation a load/speed test shall be carried out as specified in paragraph 3.10.1.1. below.

A run flat tyre tested in accordance with paragraph 3.10.1.1. shall be deemed to have passed the test if the tread remains connected to the two sidewalls and the deflected section height does not alter by a value greater than 20 per cent when compared to the deflected section height at the start of the test.

3.10.1.1. Test procedure

3.10.1.1.1. Mount a new tyre on the test rim specified by the manufacturer. Mount the tyre on a test rim with a width comprised between the minimum and maximum width as per Annex 9. The rim contour shall be one of those specified for the fitment of the test tyre.

3.10.1.1.2. Condition the tyre at (35 ± 3) °C and 250 kPa for three hours.

3.10.1.1.3. Remove the valve core and wait until the tyre deflates completely.

- 3.10.1.1.4. Mount the tyre-and-wheel assembly to a test axle and press it against the outer surface of a smooth wheel $1.7 \text{ m} \pm 1 \text{ per cent}$ or $2.0 \text{ m} \pm 1 \text{ per cent}$ in diameter.
- 3.10.1.1.5. Apply to the test axle a load equal to 65 per cent of the maximum load rating.
- 3.10.1.1.6. At the start of the test, measure the deflected section height (Z1).
- 3.10.1.1.7. During the test the temperature of the test room shall be maintained at $(35 \pm 3) \text{ }^\circ\text{C}$.
- 3.10.1.1.8. Carry the test through, without interruption in conformity with the following particulars:
 Time taken to pass from zero speed to constant test speed: 5 minutes;
 Test speed: 80 km/h; Duration of test at the test speed: 60 minutes.
- 3.10.1.1.9. At the end of the test, measure the deflected section height (Z2).
- 3.10.1.1.10. Calculate the change in per cent of the deflected section height compared to the deflected section height at the start of the test as $((Z1 - Z2) / Z1) \cdot 100$.
- 3.11. Rolling sound emission test
- 3.11.1. Requirements
- For tyres which are included within the scope of this regulation, except Professional off-road tyres, tyres fitted with additional devices to improve traction properties (e.g. studded tyres), tyres with a speed rating less than 80 km/h (speed symbol F) and those having a nominal rim diameter code ≤ 10 (or $\leq 254 \text{ mm}$) or ≥ 25 (or $\geq 635 \text{ mm}$), the rolling sound emission value shall not exceed the values given below for Class C1, Class C2 and Class C3 tyres, with reference to the categories of use and, where relevant, the nominal section widths, given in the definitions section in paragraph 2. of this regulation.

Table 24
Class C1 tyres

<i>Nominal section width</i>	<i>Limit dB(A)</i>
185 and lower	70
Over 185 up to 245	71
Over 245 up to 275	72
Over 275	74
The above limits shall be increased by 1 dB(A) for snow tyres for use in severe snow conditions, extra load tyres or any combination of these classifications.	

Table 25
Class C2 tyres

Category of use	Limit dB(A)	
	Other	Traction tyres
Normal tyre	72	73
Snow tyre	72	73
	Snow tyre for use in severe snow conditions	75
Special use tyre	74	75

Table 26
Class C3 tyres

Category of use	Limit dB(A)	
	Other	Traction tyres
Normal tyre	73	75
Snow tyre	73	75
	Snow tyre for use in severe snow conditions	76
Special use tyre	75	77

3.11.2. Coast-by test method for measuring tyre rolling sound emission

The presented method contains specifications on measuring instruments, measurement conditions and the measurement method, in order to obtain the sound level of a set of tyres mounted on a test vehicle rolling on a specified road surface. The maximum sound pressure level is to be recorded, when the test vehicle is coasting, by remote-field microphones; the final result for a reference speed is obtained from a linear regression analysis. Such test results cannot be related to tyre rolling sound measured during acceleration under power or deceleration under braking.

3.11.3. Measuring instruments

3.11.3.1. Acoustic measurements

The sound level meter or the equivalent measuring system, including the windscreen recommended by the manufacturer shall meet or exceed the requirements of Type 1 instruments in accordance with [IEC 61672-1:2013 standard](#).

The measurements shall be made using the frequency weighting A, and the time weighting F.

When using a system that includes a periodic monitoring of the A-weighted sound level, a reading should be made at a time interval not greater than 30 ms.

3.11.3.1.1. Calibration

At the beginning and at the end of every measurement session, the entire measurement system shall be checked by means of a sound calibrator that fulfils the requirements for sound calibrators of at least precision Class 1 according to IEC 60942:2003 standard.

Without any further adjustment the difference between the readings of two consecutive checks shall be less than or equal to 0.5 dB(A). If this value is exceeded, the results of the measurements obtained after the previous satisfactory check shall be discarded.

3.11.3.1.2. Compliance with requirements

The compliance of the sound calibration device with the requirements of IEC 60942:2003 standard shall be verified once a year and the compliance of the instrumentation system with the requirements of IEC 61672-1:2013 standard shall be verified at least every two years, by a laboratory which is authorized to perform calibrations traceable to the appropriate standards.

3.11.3.1.3. Positioning of the microphone

The microphone (or microphones) shall be located at a distance of 7.5 ± 0.05 m from track reference line CC' (Figure 5) and 1.2 ± 0.02 m above the ground. Its axis of maximum sensitivity shall be horizontal and perpendicular to the path of the vehicle (line CC').

3.11.3.2. Speed measurements

The vehicle speed shall be measured with instruments with accuracy of ± 1 km/h or better when the front end of the vehicle has reached line PP' (Figure 5).

3.11.3.3. Temperature measurements

Measurements of air as well as test surface temperature are mandatory.

The temperature measuring devices shall be accurate within ± 1 °C.

3.11.3.3.1. Air temperature

The temperature sensor is to be positioned in an unobstructed location close to the microphone in such a way that it is exposed to the airflow and protected from direct solar radiation. The latter may be achieved by any shading screen or similar device. The sensor should be positioned at a height of (1.2 ± 0.1) m above the test surface level, to minimize the influence of the test surface thermal radiation at low airflows.

3.11.3.3.2. Test surface temperature

The temperature sensor is to be positioned in a location where the temperature measured is representative of the temperature in the wheel tracks, without interfering with the sound measurement.

If an instrument with a contact temperature sensor is used, heat-conductive paste shall be applied between the surface and the sensor to ensure adequate thermal contact.

If a radiation thermometer (pyrometer) is used, the height should be chosen to ensure that a measuring spot with a diameter of ≥ 0.1 m is covered.

3.11.3.4. Wind measurement

The device shall be capable of measuring the wind speed with a tolerance of ± 1 m/s. The wind shall be measured at microphone height. The wind direction with reference to the driving direction shall be recorded.

3.11.4. Conditions of measurement

3.11.4.1. Test site

The test site shall consist of a central section surrounded by a substantially flat test area. The measuring section shall be level; the test surface shall be dry and clean for all measurements. The test surface shall not be artificially cooled during or prior the testing.

The test track shall be such that the conditions of a free sound field between the sound source and the microphone are attained to within 1 dB(A). These conditions shall be deemed to be met if there is no large sound reflecting objects such as fences, rocks, bridges or building within 50 m of the centre of the measuring section. The surface of the test track and the dimensions of the test site shall be in accordance with ISO 10844:2014.

A central part of at least 10 m radius shall be free of powdery snow, tall grass, loose soil, cinders or the like. There shall be no obstacle, which could affect the sound field within the vicinity of the microphone and no persons shall stand between the microphone and the sound source. The operator carrying out the measurements and any observers attending the measurements shall position themselves so as not to affect the readings of the measuring instruments.

3.11.4.2. Meteorological conditions

Measurements shall not be made under poor atmospheric conditions. It shall be ensured that the results are not affected by gusts of wind. Testing shall not be performed if the wind speed at the microphone height exceeds 5 m/s.

Measurements shall not be made if the air temperature is below 5 °C or above 40 °C or the test surface temperature is below 5 °C or above 50 °C.

3.11.4.3. Ambient noise

3.11.4.3.1. The background sound level (including any wind noise) shall be at least 10 dB(A) less than the measured tyre rolling sound emission. A suitable windscreen may be fitted to the microphone provided that account is taken of its effect on the sensitivity and directional characteristics of the microphone.

3.11.4.3.2. Any measurement affected by a sound peak which appears to be unrelated to the characteristics of the general sound level of tyres, shall be ignored.

3.11.4.4. Test vehicle requirements

3.11.4.4.1. General

The test vehicle shall be a motor vehicle and be fitted with four single tyres on just two axles.

3.11.4.4.2. Vehicle load

The vehicle shall be loaded such as to comply with the test tyre loads as specified in paragraph 3.11.4.5.2. below.

3.11.4.4.3. Wheelbase

The wheelbase between the two axles fitted with the test tyres shall for Class C1 tyres be less than 3.50 m and for Class C2 and Class C3 tyres be less than 5 m.

3.11.4.4. Measures to minimize vehicle influence on sound level measurements

To ensure that tyre rolling sound is not significantly affected by the test vehicle design the following requirements and recommendations are given.

3.11.4.4.1. Requirements:

- (a) Spray suppression flaps or other extra device to suppress spray shall not be fitted;
- (b) Addition or retention of elements in the immediate vicinity of the rims and tyres, which may screen the emitted sound, is not permitted;
- (c) Wheel alignment (toe in, camber and caster) shall be in full accordance with the vehicle manufacturer's recommendations;
- (d) Additional sound absorbing material may not be mounted in the wheel housings or under the underbody;
- (e) Suspension shall be in such a condition that it does not result in an abnormal reduction in ground clearance when the vehicle is loaded in accordance with the testing requirement. If available, body level regulation systems shall be adjusted to give a ground clearance during testing which is normal for unladen condition.

3.11.4.4.2. Recommendations to avoid parasitic noise:

- (a) Removal or modification on the vehicle that may contribute to the background noise of the vehicle is recommended. Any removals or modifications shall be recorded in the test report;
- (b) During testing it should be ascertained that brakes are not poorly released, causing brake noise;
- (c) It should be ascertained that electric cooling fans are not operating;
- (d) Windows and sliding roof of the vehicle shall be closed during testing.

3.11.4.5. Tyres

3.11.4.5.1. General

Four identical tyres shall be fitted on the test vehicle. In the case of tyres with a load index in excess of 121 and without any dual fitting indication, two of these tyres of the same type and range shall be fitted to the rear axle of the test vehicle; the front axle shall be fitted with tyres of size suitable for the axle load and planed down to the minimum depth in order to minimize the influence of tyre/road contact noise while maintaining a sufficient level of safety. Winter tyres that in certain Contracting Parties may be equipped with studs intended to enhance friction shall be tested without this equipment. Tyres with special fitting requirements shall be tested in accordance with these requirements (e.g. rotation direction). The tyres shall have full tread depth before being run-in.

Tyres are to be tested on test rims with a width comprised between the minimum and maximum width as per Annex 9. The rim contour shall be one of those specified for the fitment of the test tyre.

3.11.4.5.2. Tyre loads

The test load Q_t for each tyre on the test vehicle shall be 50 to 90 per cent of the reference load Q_r , but the average test load $Q_{t,avr}$ of all tyres shall be (75 ± 5) per cent of the reference load Q_r .

For all tyres the reference load Q_r corresponds to the maximum **load rating in single application** of the tyre. In the case where the load index is constituted by two numbers divided by a slash (/), reference shall be made to the first number.

3.11.4.5.3. Tyre inflation pressure

Each tyre fitted on the test vehicle shall have a test inflation pressure P_t not higher than the P_r and within the interval:

$$P_r \cdot \left(\frac{Q_t}{Q_r} \right)^{1.25} \leq P_t \leq 1.1 P_r \cdot \left(\frac{Q_t}{Q_r} \right)^{1.25}$$

For Class C2 and Class C3 tyres, P_r is the Reference Test Inflation Pressure marked on the tyre.

For Class C1 tyres, P_r is equal to 250 kPa for "standard" or "light load" tyres and equal to 290 kPa for "extra load" tyres; the minimum test inflation pressure shall be P_t equal to 150 kPa.

3.11.4.5.4. Preparations prior to testing

The tyres shall be "run-in" prior to testing to remove compound nodules or other tyre pattern characteristics resulting from the moulding process. This will normally require the equivalent of about 100 km of normal use on the road.

The tyres fitted to the test vehicle shall rotate in the same direction as when they were run-in.

Prior to testing tyres shall be warmed up by running under test conditions.

3.11.5. Method of testing

3.11.5.1. General conditions

For all measurements the vehicle shall be driven in a straight line over the measuring section (AA' to BB') in such a way that the median longitudinal plane of the vehicle is as close as possible to the line CC'.

When the front end of the test vehicle has reached the line AA', the vehicle's driver shall have put the gear selector on neutral position and switched off the engine. If abnormal noise (e.g. ventilator, self-ignition) is emitted by the test vehicle during the measurement, the test shall be disregarded.

3.11.5.2. Nature and number of measurements

The maximum sound level expressed in A-weighted decibels (dB(A)) shall be measured to the first decimal place as the vehicle is coasting between lines AA' and BB' (Figure 5 – front end of the vehicle on line AA', rear end of the vehicle on line BB'). This value will constitute the result of the measurement.

At least four measurements shall be made on each side of the test vehicle at test speeds lower than the reference speed specified in paragraph 3.11.6.1. and at least four measurements at test speeds higher than the reference speed. The speeds shall be approximately equally spaced over the speed range specified in paragraph 3.11.5.3.

3.11.5.3. Test speed range

The test vehicle speeds shall be within the range:

- (a) From 70 to 90 km/h for Class C1 and Class C2 tyres;
- (b) From 60 to 80 km/h for Class C3 tyres.

3.11.6. Interpretation of results

The measurement shall be invalid if an abnormal discrepancy between the values is recorded (see paragraph 3.11.4.3.2. above).

3.11.6.1. Determination of test result

The reference speed V_{ref} used to determine the final result shall be:

- (a) 80 km/h for Class C1 and Class C2 tyres;
- (b) 70 km/h for Class C3 tyres.

3.11.6.2. Regression analysis of rolling sound measurements

The tyre-road rolling sound level L_R in dB(A) is determined by a regression analysis according to:

$$L_R = \bar{L} - a \cdot \bar{v}$$

Where:

\bar{L} is the mean value of the rolling sound levels L_i , measured in dB(A):

$$\bar{L} = \frac{1}{n} \sum_{i=1}^n L_i$$

n is the measurement number ($n \geq 16$),

\bar{v} is the mean value of logarithms of speeds v_i :

$$\bar{v} = \frac{1}{n} \sum_{i=1}^n v_i \quad \text{with} \quad v_i = \lg \left(\frac{v_i}{v_{\text{ref}}} \right)$$

" a " is the slope of the regression line in dB(A):

$$a = \frac{\sum_{i=1}^n (v_i - \bar{v})(L_i - \bar{L})}{\sum_{i=1}^n (v_i - \bar{v})^2}$$

3.11.6.3. Temperature correction

For Class C1 and Class C2 tyres, the final result shall be normalized to a test surface reference temperature ϑ_{ref} by applying a temperature correction, according to the following:

$$LR(\vartheta_{\text{ref}}) = LR(\vartheta) + K(\vartheta_{\text{ref}} - \vartheta)$$

Where:

ϑ = the measured test surface temperature

$\vartheta_{\text{ref}} = 20 \text{ }^\circ\text{C}$.

For Class C1 tyres, the coefficient K is:

-0.03 dB(A)/ $^\circ\text{C}$ when $\vartheta > \vartheta_{\text{ref}}$ and

-0.06 dB(A)/ $^\circ\text{C}$ when $\vartheta < \vartheta_{\text{ref}}$.

For Class C2 tyres, the coefficient K is $-0.02 \text{ dB(A)/}^\circ\text{C}$.

If the measured test surface temperature does not change more than 5°C within all measurements necessary for the determination of the sound level of one set of tyres, the temperature correction may be made only on the final reported tyre rolling sound level as indicated above, utilizing the arithmetic mean value of the measured temperatures. Otherwise each measured sound level L_i shall be corrected, utilizing the temperature at the time of the sound recording.

- 3.11.6.4. In order to take account of any measuring instrument inaccuracies, the results according to paragraph 3.11.6.3. shall be reduced by 1 dB(A).
- 3.11.6.5. The final result, the temperature corrected tyre rolling sound level $L_R(9_{\text{ref}})$ in dB(A), shall be rounded down to the nearest lower whole value.

Figure 5

Microphone positions for the measurement

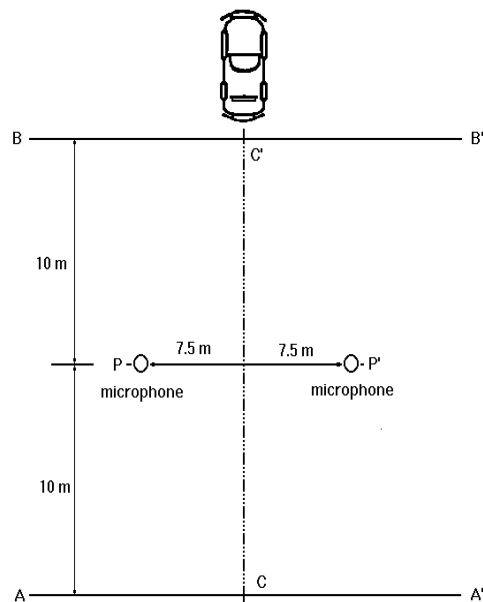

3.12. Adhesion performance on wet surfaces test

3.12.1. Requirements

The following requirements do not apply to professional off-road tyres, tyres fitted with additional devices to improve traction properties (e.g. studded tyres), tyres with a speed rating less than 80 km/h (speed symbol F) and those having a nominal rim diameter code ≤ 10 (or $\leq 254 \text{ mm}$) or ≥ 25 (or $\geq 635 \text{ mm}$).

For Class C1 tyres, tested in accordance with either procedure given in paragraph 3.12.2., the tyre shall meet the following requirements:

Table 27
Wet grip index for Class C1 tyres

<i>Category of use</i>	<i>Wet grip index (G)</i>	
Normal tyre	≥ 1.1	
Snow tyre	≥ 1.1	
	"Snow tyre for use in severe snow conditions" and with a speed symbol ("R" and above, including "H") indicating a maximum permissible speed greater than 160 km/h	≥ 1.0
	"Snow tyre for use in severe snow conditions" and with a speed symbol ("Q" or below excluding "H") indicating a maximum permissible speed not greater than 160 km/h	≥ 0.9
Special use tyre	Not defined	

For Class C2 tyres, tested in accordance with either procedure given in paragraph 3.12.3., the tyre shall meet the following requirements:

Table 28
Wet grip index for Class C2 tyres

<i>Category of use</i>	<i>Wet grip index (G)</i>	
	<i>Other</i>	<i>Traction tyres</i>
Normal tyre	≥ 0.95	≥ 0.85
Snow tyre	≥ 0.95	≥ 0.85
	Snow tyre for use in severe snow conditions	≥ 0.85
Special use tyre	≥ 0.85	≥ 0.85

For Class C3 tyres, tested in accordance with either procedure given in paragraph 3.12.3., the tyre shall meet the following requirements:

Table 29
Wet grip index for Class C3 tyres

Category of use	Wet grip index (G)		
	Other	Traction tyres	
Normal tyre	≥ 0.80	≥ 0.65	
Snow tyre	≥ 0.65	≥ 0.65	
<table border="1" style="display: inline-table; vertical-align: middle;"> <tr> <td style="padding: 2px;">Snow tyre for use in severe snow conditions</td> </tr> </table>	Snow tyre for use in severe snow conditions	≥ 0.65	≥ 0.65
Snow tyre for use in severe snow conditions			
Special use tyre	≥ 0.65	≥ 0.65	

3.12.2. **Class** C1 tyres

3.12.2.1. Reference standards

The following documents listed apply.

3.12.2.1.1. ASTM E 303-93 (Reapproved 2008), Standard Test Method for Measuring Surface Frictional Properties Using the British Pendulum Tester.

3.12.2.1.2. ASTM E 501-08, Standard Specification for Standard Rib Tyre for Pavement Skid-Resistance Tests.

3.12.2.1.3. ASTM E 965-96 (Reapproved 2006), Standard Test Method for Measuring Pavement Macrottexture Depth Using a Volumetric Technique.

3.12.2.2. General test conditions

3.12.2.2.1. Track characteristics

The test track shall have the following characteristics:

3.12.2.2.1.1. The surface shall have a dense asphalt surface with a uniform gradient of not more than 2 per cent and shall not deviate more than 6 mm when tested with a 3 m straight edge.

3.12.2.2.1.2. The surface shall have a pavement of uniform age, composition, and wear. The test surface shall be free of loose material and foreign deposits.

3.12.2.2.1.3. The maximum chipping size shall be 10 mm (tolerances permitted from 8 mm to 13 mm).

3.12.2.2.1.4. The texture depth as measured by a sand patch shall be (0.7 ± 0.3) mm. It shall be measured in accordance with ASTM E 965-96 (Reapproved 2006).

3.12.2.2.1.5. The wetted frictional properties of the surface shall be measured with either method (a) or (b) in section 3.12.2.2.2..

3.12.2.2.2. Methods to measure the wetted frictional properties of the surface

3.12.2.2.2.1. British Pendulum Number (BPN) method (a)

The British Pendulum Number method shall be as defined in ASTM E 303-93 (Reapproved in 2008).

Pad rubber component formulation and physical properties shall be as specified in ASTM E 501-08.

The averaged British Pendulum Number (BPN) shall be between 42 and 60 BPN after temperature correction as follows.

BPN shall be corrected by the wetted road surface temperature. Unless temperature correction recommendations are indicated by the British pendulum manufacturer, the following formula is used:

BPN = BPN(measured value) + temperature correction

temperature correction = $-0.0018 t^2 + 0.34 t - 6.1$

where t is the wetted road surface temperature in degrees Celsius.

Effects of slider pad wear: the pad shall be removed for maximum wear when the wear on the striking edge of the slider reaches 3.2 mm in the plane of the slider or 1.6 mm vertical to it in accordance with section 5.2.2. and Figure 3 of ASTM E 303-93 (Reapproved 2008).

For the purpose of checking track surface BPN consistency for the measurement of wet grip on an instrumented passenger car: the BPN values of the test track should not vary over the entire stopping distance so as to decrease the dispersion of test results. The wetted frictional properties of the surface shall be measured five times at each point of the BPN measurement every 10 meters and the coefficient of variation of the averaged BPN shall not exceed 10 per cent.

3.12.2.2.2.2. ASTM E 1136 Standard Reference Test Tyre method (b)

This method uses the reference tyre that has the characteristics indicated in the ASTM E 1136-93 (Reapproved 2003) and referred to as SRTT14.

The average peak braking force coefficient ($\mu_{\text{peak,ave}}$) of the SRTT14 shall be (0.7 ± 0.1) at 65 km/h.

The average peak braking force coefficient ($\mu_{\text{peak,ave}}$) of the SRTT14 shall be corrected for the wetted road surface temperature as follows:

Peak braking force coefficient ($\mu_{\text{peak,ave}}$) = peak braking force coefficient (measured) + temperature correction

Temperature correction = $0.0035 (t - 20)$

Where t is the wetted road surface temperature in degrees Celsius.

3.12.2.2.3. Atmospheric conditions

The wind conditions shall not interfere with wetting of the surface (wind-shields are allowed).

Both the wetted surface temperature and the ambient temperature shall be between 2 °C and 20 °C for snow tyres and 5 °C and 35 °C for normal tyres.

The wetted surface temperature shall not vary during the test by more than 10 °C.

The ambient temperature must remain close to the wetted surface temperature; the difference between the ambient and the wetted surface temperatures must be less than 10 °C.

3.12.2.3. Testing methods for measuring wet grip

For the calculation of the wet grip index (G) of a candidate tyre, the wet grip braking performance of the candidate tyre is compared to the wet grip braking

performance of the reference tyre on a vehicle travelling straight ahead on a wet, paved surface. It is measured with one of the following methods:

- (a) Vehicle method consisting of testing a set of tyres mounted on an instrumented passenger car;
- (b) Testing method using a trailer towed by a vehicle or a tyre test vehicle, equipped with the test tyre(s).

3.12.2.3.1. Testing method (a) using an instrumented passenger car

3.12.2.3.1.1. Principle

The testing method covers a procedure for measuring the deceleration performance of **Class C1** tyres during braking, using an instrumented passenger car equipped with an Antilock Braking System (ABS), where "instrumented passenger car" means a passenger car that is fitted with the measuring equipment listed in section 3.12.2.3.1.2.2. for the purpose of this testing method. Starting with a defined initial speed, the brakes are applied hard enough on four wheels at the same time to activate the ABS. The average deceleration is calculated between two pre-defined speeds.

3.12.2.3.1.2. Equipment

3.12.2.3.1.2.1. Vehicle

Permitted modifications on the passenger car are as follows:

- (a) Those allowing the number of tyre sizes that can be mounted on the vehicle to be increased;
- (b) Those permitting automatic activation of the braking device to be installed;
- (c) Any other modification of the braking system is prohibited.

3.12.2.3.1.2.2. Measuring equipment

The vehicle shall be fitted with a sensor suitable for measuring speed on a wet surface and distance covered between two speeds.

To measure vehicle speed, a fifth wheel or non-contact speed-measuring system shall be used.

3.12.2.3.1.3. Conditioning of the test track and wetting condition

The test track surface shall be watered at least half an hour prior to testing in order to equalize the surface temperature and water temperature. External watering should be supplied continuously throughout testing. For the whole testing area, the water depth shall be (1.0 ± 0.5) mm, measured from the peak of the pavement.

The test track should then be conditioned by conducting at least ten test runs with tyres not involved in the test programme at 90 km/h.

3.12.2.3.1.4. Tyres and rims

3.12.2.3.1.4.1. Tyre preparation and break-in

The test tyres shall be trimmed to remove all protuberances on the tread surface caused by mould air vents or flashes at mould junctions.

Mount the tyre on a test rim with a width comprised between the minimum and maximum width as per Annex 9. The rim contour shall be one of those specified for the fitment of the test tyre.

3.12.2.3.1.4.2. Tyre load

The static load on each axle tyre shall lie between 60 per cent and 90 per cent of the tested maximum load rating of the tested tyre. Tyre loads on the same axle should not differ by more than 10 per cent.

3.12.2.3.1.4.3. Tyre inflation pressure

On the front and rear axles, the inflation pressures shall be 220 kPa (for standard- and extra load tyres). The tyre pressure should be checked just prior to testing at ambient temperature and adjusted if required.

3.12.2.3.1.5. Procedure

3.12.2.3.1.5.1. Test run

The following test procedure applies for each test run.

3.12.2.3.1.5.1.1. The passenger car is driven in a straight line up to 85 ± 2 km/h.

3.12.2.3.1.5.1.2. Once the passenger car has reached 85 ± 2 km/h, the brakes are always activated at the same place on the test track referred to as "braking starting point", with a longitudinal tolerance of 5 m and a transverse tolerance of 0.5 m.

3.12.2.3.1.5.1.3. The brakes are activated either automatically or manually.

3.12.2.3.1.5.1.3.1. The automatic activation of the brakes is performed by means of a detection system made of two parts, one indexed to the test track and one on board the passenger car.

3.12.2.3.1.5.1.3.2. The manual activation of the brakes depends on the type of transmission as follows. In both cases, a minimum of 600 N pedal efforts is required.

For manual transmission, the driver should release the clutch and depress the brake pedal sharply, holding it down as long as necessary to perform the measurement.

For automatic transmission, the driver should select neutral gear and then depress the brake pedal sharply, holding it down as long as necessary to perform the measurement.

3.12.2.3.1.5.1.4. The average deceleration is calculated between 80 km/h and 20 km/h.

If any of the specifications listed above (including speed tolerance, longitudinal and transverse tolerance for the braking starting point, and braking time) are not met when a test run is made, the measurement is discarded, and a new test run is made.

3.12.2.3.1.5.2. Test cycle

A number of test runs are made in order to measure the wet grip index of a set of candidate tyres (T) according to the following procedure, whereby each test run shall be made in the same direction and up to three different sets of candidate tyres may be measured within the same test cycle:

3.12.2.3.1.5.2.1. First, the set of reference tyres are mounted on the instrumented passenger car.

- 3.12.2.3.1.5.2.2. After at least three valid measurements have been made in accordance with section 3.12.2.3.1.5.1, the set of reference tyres is replaced by a set of candidate tyres.
- 3.12.2.3.1.5.2.3. After six valid measurements of the candidate tyres are performed, two more sets of candidate tyres may be measured.
- 3.12.2.3.1.5.2.4. The test cycle is closed by three more valid measurements of the same set of reference tyres as at the beginning of the test cycle.

Examples:

- (a) The run order for a test cycle of three sets of candidate tyres (T1 to T3) plus a set of reference tyres (R) would be the following:

R – T1 – T2 – T3 – R

- (b) The run order for a test cycle of five sets of candidate tyres (T1 to T5) plus a set of reference tyres (R) would be the following:

R – T1 – T2 – T3 – R – T4 – T5 – R

- 3.12.2.3.1.6. Processing of measurement results
- 3.12.2.3.1.6.1. Calculation of the average deceleration (AD)

The average deceleration (AD) is calculated for each valid test run in m/s² as follows:

$$AD = \left| \frac{S_f^2 - S_i^2}{2d} \right|$$

where:

S_f is the final speed in m/s; S_f = 20 km/h = 5.556 m/s

S_i is the initial speed in m/s; S_i = 80 km/h = 22.222 m/s

d is the distance covered between S_i and S_f in meters.

- 3.12.2.3.1.6.2. Validation of results

The AD coefficient of variation is calculated as follows:

(Standard Deviation / Average) × 100.

For the reference tyres (R): If the AD coefficient of variation of any two consecutive groups of three tests runs of the reference tyre set is higher than 3 per cent, all data should be discarded, and the test repeated for all test tyres (the candidate tyres and the reference tyres).

For the candidate tyres (T): The AD coefficients of variation are calculated for each candidate tyre set. If one coefficient of variation is higher than 3 per cent, the data should be discarded, and the test repeated for that candidate tyre set.

- 3.12.2.3.1.6.3. Calculation of adjusted average deceleration (Ra)

The average deceleration (AD) of the reference tyre set used for the calculation of its braking force coefficient is adjusted according to the positioning of each candidate tyre set in a given test cycle.

This adjusted AD of the reference tyre (Ra) is calculated in m/s² in accordance with the following table where R₁ is the average of the AD values in the first

test of the reference tyre set (R) and R_2 is the average of the AD values in the second test of the same reference tyre set (R).

Table 30

Adjusted average deceleration (Ra) calculation

<i>Number of sets of candidate tyres within one test cycle</i>	<i>Set of candidate tyres</i>	<i>Ra</i>
1 ($R_1 - T_1 - R_2$)	T1	$Ra = 1/2 (R_1 + R_2)$
2 ($R_1 - T_1 - T_2 - R_2$)	T1	$Ra = 2/3 R_1 + 1/3 R_2$
	T2	$Ra = 1/3 R_1 + 2/3 R_2$
3 ($R_1 - T_1 - T_2 - T_3 - R_2$)	T1	$Ra = 3/4 R_1 + 1/4 R_2$
	T2	$Ra = 1/2 (R_1 + R_2)$
	T3	$Ra = 1/4 R_1 + 3/4 R_2$

3.12.2.3.1.6.4. Calculation of the braking force coefficient (BFC)

The braking force coefficient (BFC) is calculated for a braking on the two axles according to the following table where T_a ($a = 1, 2$ or 3) is the average of the AD values for each candidate tyre (T) set that is part of a test cycle

Table 31

Braking force coefficient calculation

<i>Test Tyre</i>	<i>Braking force coefficient</i>
Reference tyre	$BFC(R) = Ra/g $
Candidate tyre	$BFC(T) = Ta/g $
g is the acceleration due to gravity, $g = 9.81 \text{ m/s}^2$	

3.12.2.3.1.6.5. Calculation of the wet grip index of the candidate tyre

The wet grip index of the candidate tyre ($G(T)$) is calculated as follows:

$$G(T) = \left[\frac{BFC(T)}{BFC(R)} \cdot 125 + a \cdot (t - t_0) + b \cdot \left(\frac{BFC(R)}{BFC(R_0)} - 1.0 \right) \right] \cdot 10^{-2}$$

where:

t is the measured wet surface temperature in degrees Celsius when the candidate tyre (T) is tested

t_0 is the wet surface reference temperature condition, $t_0 = 20 \text{ }^\circ\text{C}$ for normal tyres and $t_0 = 10 \text{ }^\circ\text{C}$ for snow tyres

$BFC(R_0)$ is the braking force coefficient for the reference tyre in the reference conditions, $BFC(R_0) = 0.68$

$a = -0.4232$ and $b = -8.297$ for normal tyres, $a = 0.7721$ and $b = 31.18$ for snow tyres. a is expressed as ($1/^\circ\text{C}$)

3.12.2.3.1.7. Wet grip performance comparison between a candidate tyre and a reference tyre using a control tyre

3.12.2.3.1.7.1. General

Where the candidate tyre size is significantly different from that of the reference tyre, a direct comparison on the same instrumented passenger car may not be possible. This testing method uses an intermediate tyre, hereinafter called the control tyre as defined in paragraph 2.

3.12.2.3.1.7.2. Principle of the approach

The principle is the use of a control tyre set and two different instrumented passenger cars for the test cycle of a candidate tyre set in comparison with a reference tyre set.

One instrumented passenger car is fitted with the reference tyre set followed by the control tyre set, the other with the control tyre set followed by the candidate tyre set.

The specifications listed in sections 3.12.2.3.1.2. to 3.12.2.3.1.4. apply.

The first test cycle is a comparison between the control tyre set and the reference tyre set.

The second test cycle is a comparison between the candidate tyre set and the control tyre set. It is done on the same test track and during the same day as the first test cycle. The wetted surface temperature shall be within ± 5 °C of the temperature of the first test cycle. The same control tyre set shall be used for the first and the second test cycles.

The wet grip index of the candidate tyre ($G(T)$) is calculated as follows:

$$G(T) = G_1 \cdot G_2$$

where:

G_1 is the relative wet grip index of the control tyre (C) compared to the reference tyre (R) calculated as follows:

$$G_1 = \left[\frac{BFC(C)}{BFC(R)} \cdot 125 + a \cdot (t - t_0) + b \cdot \left(\frac{BFC(R)}{BFC(R_0)} - 1.0 \right) \right] \cdot 10^{-2}$$

G_2 is the relative wet grip index of the candidate tyre (T) compared to the control tyre (C) calculated as follows:

$$G_2 = \frac{BFC(T)}{BFC(C)}$$

3.12.2.3.1.7.3. Storage and preservation

It is necessary that all the tyres of a control tyre set have been stored in the same conditions. As soon as the control tyre set has been tested in comparison with the reference tyre, the specific storage conditions defined in ASTM E 1136-93 (Reapproved 2003) shall be applied.

3.12.2.3.1.7.4. Replacement of reference tyres and control tyres

When irregular wear or damage results from tests, or when wear influences the test results, the use of the tyre shall be discontinued.

3.12.2.3.2. Testing method (b) using a trailer towed by a vehicle or a tyre test vehicle

3.12.2.3.2.1. Principle

The measurements are conducted on test tyres mounted on a trailer towed by a vehicle (hereafter referred to as tow vehicle) or on a tyre test vehicle. The brake

in the test position is applied firmly until sufficient braking torque is generated to produce the maximum braking force that will occur prior to wheel lockup at a test speed of 65 km/h.

3.12.2.3.2.2. Equipment

3.12.2.3.2.2.1. Tow vehicle and trailer or tyre test vehicle

The tow vehicle or the tyre test vehicle shall have the capability of maintaining the specified speed of 65 ± 2 km/h even under the maximum braking forces.

The trailer or the tyre test vehicle shall be equipped with one place where the tyre can be fitted for measurement purposes hereafter called 'test position' and the following accessories:

- (a) Equipment to activate brakes in the test position;
- (b) A water tank to store sufficient water to supply the road surface wetting system, unless external watering is used;
- (c) Recording equipment to record signals from transducers installed at the test position and to monitor water application rate if the self-watering option is used.

The maximum variation of toe-settings and camber angle for the test position shall be within $\pm 0.5^\circ$ with maximum vertical load. Suspension arms and bushings shall have sufficient rigidity necessary to minimize free play and ensure compliance under application of maximum braking forces. The suspension system shall provide adequate load-carrying capacity and be of such a design as to isolate suspension resonance.

The test position shall be equipped with a typical or special automotive brake system which can apply sufficient braking torque to produce the maximum value of braking test wheel longitudinal force at the conditions specified.

The brake application system shall be able to control the time interval between initial brake application and peak longitudinal force as specified in paragraph 3.12.2.3.2.7.1. below.

The trailer or the tyre test vehicle shall be designed to accommodate the range of candidate tyre sizes to be tested.

The trailer or the tyre test vehicle shall have provisions for adjustment of vertical load as specified in paragraph 3.12.2.3.2.5.2. below;

3.12.2.3.2.2.2. Measuring equipment

The test wheel position on the trailer or the tyre test vehicle shall be equipped with a rotational wheel velocity measuring system and with transducers to measure the braking force and vertical load at the test wheel.

General requirements for measurement system: The instrumentation system shall conform to the following overall requirements at ambient temperatures between 0 °C and 45 °C:

- (a) Overall system accuracy, force: ± 1.5 per cent of the full scale of the vertical load or braking force;
- (b) Overall system accuracy, speed: ± 1.5 per cent of speed or ± 1.0 km/h, whichever is greater.

Vehicle speed: To measure vehicle speed, a fifth wheel or non-contact precision speed-measuring system should be used.

Braking forces: The braking force-measuring transducers shall measure longitudinal force generated at the tyre-road interface as a result of brake application within a range from 0 per cent to at least 125 per cent of the applied vertical load. The transducer design and location shall minimize inertial effects and vibration-induced mechanical resonance.

Vertical load: The vertical load-measuring transducer shall measure the vertical load at the test position during brake application. The transducer shall have the same specifications as described previously.

Signal conditioning and recording system: All signal conditioning and recording equipment shall provide linear output with necessary gain and data reading resolution to meet the specified previous requirements. In addition, the following requirements apply:

- (a) The minimum frequency response shall be flat from 0 Hz to 50 Hz (100 Hz) within ± 1 per cent full scale;
- (b) The signal-to-noise ratio shall be at least 20/1;
- (c) The gain shall be sufficient to permit full-scale display for full-scale input signal level;
- (d) The input impedance shall be at least ten times larger than the output impedance of the signal source;
- (e) The equipment shall be insensitive to vibrations, acceleration, and changes in ambient temperature.

3.12.2.3.2.3. Conditioning of the test track

The test track should be conditioned by conducting at least ten test runs with tyres not involved in the test programme at (65 ± 2) km/h.

3.12.2.3.2.4. Wetting conditions

The tow vehicle and trailer or the tyre test vehicle may be optionally equipped with a pavement-wetting system, less the storage tank, which, in the case of the trailer, is mounted on the tow vehicle. The water being applied to the pavement ahead of the test tyres shall be supplied by a nozzle suitably designed to ensure that the water layer encountered by the test tyre has a uniform cross section at the test speed with a minimum splash and overspray.

The nozzle configuration and position shall ensure that the water jets are directed towards the test tyre and pointed towards the pavement at an angle of 20° to 30° .

The water shall strike the pavement 250 mm to 450 mm ahead of the centre of tyre contact. The nozzle shall be located 25 mm above the pavement or at the minimum height required to clear obstacles which the tester is expected to encounter, but in no case more than 100 mm above the pavement.

The water layer shall be at least 25 mm wider than the test tyre tread and applied so the tyre is centrally located between the edges. Water delivery rate shall ensure a water depth of (1.0 ± 0.5) mm and shall be consistent throughout the test to within ± 10 per cent. The volume of water per unit of wetted width shall be directly proportional to the test speed. The quantity of water applied

at 65 km/h shall be 18 l/s per meter of width of wetted surface in case of a water depth of 1.0 mm.

3.12.2.3.2.5. Tyres and rims

3.12.2.3.2.5.1. Tyre preparation and break-in

The test tyres shall be trimmed to remove all protuberances on the tread surface caused by mould air vents or flashes at mould junctions.

Mount the tyre on a test rim with a width comprised between the minimum and maximum width as per Annex 9.

A proper bead seat should be achieved by the use of a suitable lubricant. Excessive use of lubricant should be avoided to prevent slipping of the tyre on the wheel rim.

The test tyres/rim assemblies shall be stored in a location for a minimum of two hours such that they all have the same ambient temperature prior to testing. They should be shielded from the sun to avoid excessive heating by solar radiation.

For tyre break-in, at least two braking runs shall be performed under the load, pressure and speed as specified in paragraphs 3.12.2.3.4.2.5.2, 3.12.2.3.4.2.5.3 and 3.12.2.3.4.2.7.1 respectively.

3.12.2.3.2.5.2. Tyre load

The test load on the test tyre is (75 ± 5) per cent of the maximum load rating.

3.12.2.3.2.5.3. Tyre inflation pressure

The test tyre cold inflation pressure shall be 180 kPa for standard-load tyres. For extra load tyres, the cold inflation pressure shall be 220 kPa.

The tyre pressure should be checked just prior to testing at ambient temperature and adjusted if required.

3.12.2.3.2.6. Preparation of the tow vehicle and trailer or the tyre test vehicle

3.12.2.3.2.6.1. Trailer

For one axle trailers, the hitch height and transverse position shall be adjusted once the test tyre has been loaded to the specified test load in order to avoid any disturbance of the measuring results. The longitudinal distance from the centre line of the articulation point of the coupling to the transverse centre line of the axle of the trailer shall be at least ten times the "hitch height" or the "coupling (hitch) height".

3.12.2.3.2.6.2. Instrumentation and equipment

Install the fifth wheel, when used, in accordance with the manufacturer's specifications and locate it as near as possible to the mid-track position of the tow trailer or the tyre test vehicle.

3.12.2.3.2.7. Procedure

3.12.2.3.2.7.1. Test run

The following procedure applies for each test run:

3.12.2.3.2.7.1.1. The tow vehicle or the tyre test vehicle is driven onto the test track in a straight line at the specified test speed (65 ± 2) km/h.

- 3.12.2.3.2.7.1.2. The recording system is launched.
- 3.12.2.3.2.7.1.3. Water is delivered to the pavement ahead of the test tyre approximately 0.5 s prior to brake application (for internal watering system).
- 3.12.2.3.2.7.1.4. The trailer brakes are activated within 2 meters of a measurement point of the wetted frictional properties of the surface and sand depth in accordance with paragraphs 3.12.2.2.1.4. and 3.12.2.2.1.5.. The rate of braking application shall be such that the time interval between initial application of force and peak longitudinal force is in the range 0.2 s to 0.5 s.
- 3.12.2.3.2.7.1.5. The recording system is stopped.
- 3.12.2.3.2.7.2. Test cycle

A number of test runs are made in order to measure the wet grip index of the candidate tyre (T) according to the following procedure, whereby each test run shall be made from the same spot on the test track and in the same direction. Up to three candidate tyres may be measured within the same test cycle, provided that the tests are completed within one day.

- 3.12.2.3.2.7.2.1. First, the reference tyre is tested.
- 3.12.2.3.2.7.2.2. After at least six valid measurements are performed in accordance with paragraph 3.12.2.3.2.7.1. the reference tyre is replaced by the candidate tyre.
- 3.12.2.3.2.7.2.3. After six valid measurements of the candidate tyre are performed, two more candidate tyres may be measured.
- 3.12.2.3.2.7.2.4. The test cycle is closed by six more valid measurements of the same reference tyre as at the beginning of the test cycle.

Examples:

- (a) The run order for a test cycle of three candidate tyres (T1 to T3) plus the reference tyre (R) would be the following:

R – T1 – T2 – T3 – R

- (b) The run order for a test cycle of five candidate tyres (T1 to T5) plus the reference tyre R would be the following:

R – T1 – T2 – T3 – R – T4 – T5 – R

- 3.12.2.3.2.8. Processing of measurement results
- 3.12.2.3.2.8.1. Calculation of the peak braking force coefficient

The tyre peak braking force coefficient (μ_{peak}) is the highest value of $\mu(t)$ before lockup occurs calculated as follows for each test run. Analogue signals should be filtered to remove noise. Digitally recorded signals must be filtered using a moving average technique.

$$\mu(t) = \left| \frac{f_h(t)}{f_v(t)} \right|$$

where:

$\mu(t)$ is the dynamic tyre braking force coefficient in real time;

$f_h(t)$ is the dynamic braking force in real time, in N;

$f_v(t)$ is the dynamic vertical load in real time, in N.

3.12.2.3.2.8.2. Validation of results

The μ_{peak} coefficient of variation is calculated as follows:

$$(\text{Standard Deviation} / \text{Average}) \times 100$$

For the reference tyre (R): If the coefficient of variation of the peak braking force coefficient (μ_{peak}) of the reference tyre is higher than 5 per cent, all data should be discarded, and the test repeated for all test tyres (the candidate tyre(s) and the reference tyre).

For the candidate tyre(s) (T): The coefficient of variation of the peak braking force coefficient (μ_{peak}) is calculated for each candidate tyre. If one coefficient of variation is higher than 5 per cent, the data should be discarded, and the test repeated for this candidate tyre.

3.12.2.3.2.8.3. Calculation of the adjusted average peak braking force coefficient

The average peak braking force coefficient of the reference tyre used for the calculation of its braking force coefficient is adjusted according to the positioning of each candidate tyre in a given test cycle.

This adjusted average peak braking force coefficient of the reference tyre (R_a) is calculated in accordance with the following table where R_1 is the average peak tyre braking coefficient in the first test of the reference tyre (R) and R_2 is the average peak tyre braking coefficient in the second test of the same reference tyre (R).

Table 32

Adjusted average peak braking force coefficient of the reference tyre (R_a) calculation

<i>Number of candidate tyre(s) within one test cycle</i>	<i>Candidate tyre</i>	<i>R_a</i>
1 ($R_1 - T_1 - R_2$)	T1	$R_a = 1/2 (R_1 + R_2)$
2 ($R_1 - T_1 - T_2 - R_2$)	T1	$R_a = 2/3 R_1 + 1/3 R_2$
	T2	$R_a = 1/3 R_1 + 2/3 R_2$
3 ($R_1 - T_1 - T_2 - T_3 - R_2$)	T1	$R_a = 3/4 R_1 + 1/4 R_2$
	T2	$R_a = 1/2 (R_1 + R_2)$
	T3	$R_a = 1/4 R_1 + 3/4 R_2$

3.12.2.3.2.8.4. Calculation of the average peak braking coefficient ($\mu_{peak,ave}$)

The average value of the peak braking coefficients ($\mu_{peak,ave}$) is calculated according to the following table whereby T_a ($a= 1, 2$ or 3) is the average of the peak braking force coefficients measured for one candidate tyre within one test cycle.

Table 33

Average peak braking coefficient calculation

<i>Test tyre</i>	<i>$\mu_{peak,ave}$</i>
------------------	------------------------------------

Reference tyre	$\mu_{\text{peak,ave}}(\text{R}) = \text{Ra}$ as per Table 3
Candidate tyre	$\mu_{\text{peak,ave}}(\text{T}) = \text{Ta}$

3.12.2.3.2.8.5. Calculation of the wet grip index of the candidate tyre

The wet grip index of the candidate tyre (G(T)) is calculated as follows:

$$G(T) = \left[\frac{\mu_{\text{peak,ave}}(T)}{\mu_{\text{peak,ave}}(R)} \cdot 125 + a \cdot (t - t_0) + b \cdot \left(\frac{\mu_{\text{peak,ave}}(R)}{\mu_{\text{peak,ave}}(R_0)} - 1.0 \right) \right] \cdot 10^{-2}$$

where:

t is the measured wet surface temperature in degree Celsius when the candidate tyre (T) is tested

t₀ is the wet surface reference temperature condition

t₀ = 20 °C for normal tyres t₀ = 10 °C for snow tyres

$\mu_{\text{peak,ave}}(R_0) = 0.85$ is the peak braking force coefficient for the reference tyre in the reference conditions

a = -0.4232 and b = -8.297 for normal tyres, a = 0.7721 and b = 31.18 for snow tyres" a is expressed as (1/°C)

3.12.3. Class C2 and Class C3 tyres

3.12.3.1. General test conditions

3.12.3.1.1. Track characteristics

The surface shall be a dense asphalt surface with a uniform gradient of not more than two per cent and shall not deviate more than 6 mm when tested with a 3 m straightedge.

The test surface shall have a pavement of uniform age, composition, and wear. The test surface shall be free of loose material or foreign deposits.

The maximum chipping size shall be from 8 mm to 13 mm.

The sand depth measured as specified in EN13036-1:2001 and ASTM E 965-96 (reapproved 2006) shall be (0.7 ± 0.3) mm.

The surface friction value for the wetted track shall be established by one or other of the following methods.

3.12.3.1.1.1. Standard reference test tyre (SRTT) method

The average peak braking coefficient (μ peak average) of the ASTM E1136 - 93 (reapproved 2003) reference tyre (Test method using a trailer, or a tyre test vehicle as specified in clause 2.1) shall be (0.7 ± 0.1) (at 65 km/h and 180 kPa). The measured values shall be corrected for the effects of temperature as follows:

$$\text{pbfc} = \text{pbfc (measured)} + 0.0035 \cdot (t - 20)$$

Where "t" is the wetted track surface temperature in degrees Celsius.

The test shall be conducted using the lanes and length of the track to be used for the wet grip test.

For the trailer method, testing is run in such a way that braking occurs within 10 meters distance of where the surface was characterized.

3.12.3.1.1.2. British Pendulum Number (BPN) method

The averaged British Pendulum Number (BPN) British Pendulum Tester method as specified in ASTM E 303-93 (reapproved 2008) using the Pad as specified in ASTM E 501-08 shall be (50 ± 10) BPN after temperature correction.

BPN shall be corrected by the wetted road surface temperature. Unless temperature correction recommendations are indicated by the British pendulum manufacturer the following formula can be used:

$$\text{BPN} = \text{BPN (measured value)} - (0.0018 t^2) + 0.34 t - 6.1$$

Where: "t" is the wetted road surface temperature in degrees Celsius.

Effects of slider pad wear: the pad should be removed for maximum wear when the wear on the striking edge of the slider reaches 3.2 mm in the plane of the slider or 1.6 mm vertical to it.

Check the test track testing surface BPN consistency for the measurement of wet grip on a standard vehicle.

In the lanes of the track to be used during the wet grip tests, the BPN shall be measured at intervals of 10 m along the length of the lanes. The BPN shall be measured 5 times at each point and the coefficient of variation of the BPN averages shall not exceed 10 per cent.

3.12.3.1.2. The surface may be wetted from the track-side or by a wetting system incorporated into the test vehicle or the trailer.

If a track-side system is used, the test surface shall be wetted for at least half an hour prior to testing in order to equalize the surface temperature and water temperature. It is recommended that track-side wetting be continuously applied throughout testing.

The water depth shall be between 0.5 and 2.0 mm.

3.12.3.1.3. The wind conditions shall not interfere with wetting of the surface (wind-shields are permitted).

The ambient and the wetted surface temperature shall be between 5 °C and 35 °C and shall not vary during the test by more than 10 °C.

3.12.3.1.4. In order to cover the range of the tyre sizes fitting the commercial vehicles, three Standard Reference Testing Tyre (SRTT) sizes shall be used to measure the relative wet index:

- (a) SRTT 315/70R22.5 LI=154/150, ASTM F2870
- (b) SRTT 245/70R19.5 LI=136/134, ASTM F2871
- (c) SRTT 225/75 R 16 C LI=116/114, ASTM F2872

The three standard reference testing tyre sizes shall be used to measure the relative wet index as shown in the following table:

Table 34

Standard reference testing tyre size selection

<i>For Class C3 tyres</i>	
Narrow family $S_{Nominal} < 285 \text{ mm}$	Wide family $S_{Nominal} \geq 285 \text{ mm}$
SRTT 245/70R19.5 LI=136/134	SRTT 315/70R22.5 LI=154/150
<i>For Class C2 tyres</i>	
SRTT 225/75 R 16 C LI=116/114	
$S_{Nominal} = \text{Tyre nominal section width}$	

3.12.3.2. Test procedure

The comparative wet grip performance shall be established using either:

- (a) A trailer or special purpose tyre evaluation vehicle; or
- (b) A standard production vehicle as defined in Special Resolution No. 1 concerning the common definitions of vehicle categories, masses and dimensions (S.R.1) contained in ECE/TRANS/WP.29/1045 and subsequent amendments.

3.12.3.2.1. Trailer or special purpose tyre evaluation vehicle procedure

- 3.12.3.2.1.1. The measurements are conducted on (a) tyre(s) mounted on a trailer towed by a vehicle or a tyre test vehicle.

The brake on the test position is applied firmly until sufficient braking torque results to produce maximum braking force that will occur prior to wheel lockup at a test speed of 50 km/h. The trailer, together with the towing vehicle, or the tyre evaluation vehicle shall comply with the following requirements:

- 3.12.3.2.1.1.1. Be capable of exceeding the upper limit for the test speed of 50 km/h and of maintaining the test speed requirement of (50 ± 2) km/h even at the maximum level of application of braking forces;
- 3.12.3.2.1.1.2. Be equipped with an axle providing one test position having a hydraulic brake and actuation system that can be operated at the test position from the towing vehicle if applicable. The braking system shall be capable of providing sufficient braking torque to achieve the peak brake force coefficient over the range of tyre sizes and tyre loads to be tested;
- 3.12.3.2.1.1.3. Be capable of maintaining longitudinal alignment (toe) and camber of the test wheel and tyre assembly throughout the test within $\pm 0.5^\circ$ of the static figures achieved at the test tyre loaded condition;
- 3.12.3.2.1.1.4. In the case a track wetting system is incorporated:

The system shall be able to deliver the water such that the tyre and track surface in front of the tyre are wetted before the start of braking and throughout the duration of the test. The apparatus may be optionally equipped with a pavement-wetting system, less the storage tank, which, in the case of the trailer, is mounted on the tow vehicle. The water being applied to the pavement ahead of the test tyres shall be supplied by a nozzle suitably designed to ensure that the water layer encountered by the test tyre has a uniform cross section at the test speed with a minimum splash and overspray.

The nozzle configuration and position shall ensure that the water jets shall be directed toward the test tyre and pointed toward the pavement at an angle of 15° to 30°. The water shall strike the pavement 0.25 to 0.5 m ahead of the centre of tyre contact. The nozzle shall be located 100 mm above the pavement or the minimum height required to clear obstacles which the tester is expected to encounter, but in no case more than 200 mm above the pavement. The water layer shall be at least 25 mm wider than the test tyre tread and applied so the tyre is centrally located between the edges. The volume of water per unit of wetted width shall be directly proportional to the test speed. The quantity of water applied at 50 km/h shall be 14 l/s per meter of the width of the wetted surface. The nominal values of rate of water application shall be maintained within ±10 per cent.

3.12.3.2.1.2. Test procedure

- 3.12.3.2.1.2.1. Mount the tyre on a test rim with a width comprised between the minimum and maximum width as per Annex 9. The rim contour shall be one of those specified for the fitment of the test tyre.

Ensure proper bead seating by the use of a suitable lubricant. Excessive use of lubricant should be avoided to prevent slipping of the tyre on the wheel rim.

Check the test tyres for the specified inflation pressure at ambient temperature (cold), just prior to testing. For the purpose of this standard the testing tyre cold inflation pressure P_t shall be calculated as follows:

$$P_t = P_r \cdot \left(\frac{Q_t}{Q_r} \right)^{1.25}$$

Where:

P_r is the Reference Test Inflation pressure.

Q_t = The static test load of the tyre

Q_r = The maximum load rating of the tyre

- 3.12.3.2.1.2.2. For tyre break-in, two braking runs are performed. The tyre shall be conditioned for a minimum of two hours such that it is stabilized at the ambient temperature of the test track area. The tyre(s) shall not be exposed to direct sunshine during conditioning.
- 3.12.3.2.1.2.3. The load conditions for testing shall be 75 ± 5 per cent of the maximum load rating.
- 3.12.3.2.1.2.4. Shortly before testing, the track shall be conditioned by carrying out at least ten braking test runs at 50 km/h on the part of the track to be used for the performance test programme but using a tyre not involved in that programme;
- 3.12.3.2.1.2.5. Immediately prior to testing, the tyre inflation pressure shall be checked and reset, if necessary, to the values given in paragraph 3.12.3.2.1.2.1.
- 3.12.3.2.1.2.6. The test speed shall be at 50 ± 2 km/h and shall be maintained between these limits throughout the test run.
- 3.12.3.2.1.2.7. The direction of the test shall be the same for each set of tests and shall be the same for the test tyre as that used for the SRTT with which its performance is to be compared.
- 3.12.3.2.1.2.8. Deliver water to the pavement ahead of the test tyre approximately 0.5 s prior to brake application (for internal watering system). The brakes of the test wheel

assembly shall be applied such that peak braking force is achieved within 0.2 s and 1.0 s of brake application.

- 3.12.3.2.1.2.9. For new tyres, the first two braking runs are discarded for tyre break-in.
- 3.12.3.2.1.2.10. For the evaluation of the performance of any tyre compared with that of the SRTT, the braking test should be run at the same area on the test pad.
- 3.12.3.2.1.2.11. The order of testing shall be:

R1 – T – R2

Where:

R1 = the initial test of the SRTT,

R2 = the repeat test of the SRTT and

T = the test of the candidate tyre to be evaluated.

A maximum of three candidate tyres may be tested before repeating the SRTT test, for example:

R1 – T1 – T2 – T3 – R2

- 3.12.3.2.1.2.12. Calculate the peak braking force coefficient, μ_{peak} , for each test using the following equation:

$$\mu(t) = \left| \frac{f_h(t)}{f_v(t)} \right| \quad (1)$$

Where:

$\mu(t)$ = dynamic tyre braking force coefficient in real time,

$f_h(t)$ = dynamic braking force in real time, N,

$f_v(t)$ = dynamic vertical load in real time, N.

Using equation (1) for dynamic tyre braking force coefficient, calculate the peak tyre braking force coefficient, μ_{peak} , by determining the highest value of $\mu(t)$ before lockup occurs. Analogic signals should be filtered to remove noise. Digitally recorded signals may be filtered using a moving average technique.

Calculate the average values of peak-braking coefficient ($\mu_{\text{peak, ave}}$) by averaging four or more valid repeated runs for each set of test and reference tyres for each test condition provided that the tests are completed within the same day.

- 3.12.3.2.1.2.13. Validation of results

For the reference tyre:

If the coefficient of variation of the peak braking coefficient, which is calculated by "standard deviation/average x 100" of the reference tyre is higher than five per cent, discard all data and repeat the test for this reference tyre.

For the candidate tyres:

The coefficients of variation (standard deviation/average x 100) are calculated for all the candidate tyres. If one coefficient of variation is greater than five per cent, discard the data for this candidate tyre and repeat the test.

If R1 is the average of the peak braking coefficient in the first test of the reference tyre, R2 is the average of the peak braking coefficient in the second

test of the reference tyre, the following operations are performed, according to the following table:

Table 35

“Ra” calculation

<i>If the number of sets of candidate tyres between two successive runs of the reference tyre is:</i>	<i>and the set of candidate tyres to be qualified is:</i>	<i>then "Ra" is calculated by applying the following:</i>
1 R1 – T1 – R2	T1	Ra = 1/2 (R1 + R2)
2 R1 – T1 – T2 – R2	T1	Ra = 2/3 R1 + 1/3 R2
	T2	Ra = 1/3 R1 + 2/3 R2
3 R1 – T1 – T2 – T3 – R2	T1	Ra = 3/4 R1 + 1/4 R2
	T2	Ra = 1/2 (R1 + R2)
	T3	Ra = 1/4 R1 + 3/4 R2

3.12.3.2.1.2.14. The wet grip index (G) shall be calculated as:

$$\text{Wet grip index (G)} = \mu_{\text{peak,ave}} (\text{T}) / \mu_{\text{peak,ave}} (\text{R})$$

It represents the relative Wet Grip Index for braking performance of the candidate tyre (T) compared to the reference tyre (R).

3.12.3.2.2. Standard vehicle procedure

3.12.3.2.2.1. The vehicle used shall have two axles and be equipped with an anti-lock braking system. The ABS shall continue to fulfil the utilisation of adhesion requirements defined in the Regulations as appropriate and shall be comparable and constant throughout the tests with the different tyres mounted.

3.12.3.2.2.1.1. Measuring equipment

The vehicle shall be fitted with a sensor suitable for measuring speed on a wet surface and distance covered between two speeds.

To measure vehicle speed, a fifth wheel or non-contact speed-measuring system shall be used.

The following tolerances shall be respected:

- (a) For the speed measurements: ± 1 per cent or ± 0.5 km/h whichever is greater;
- (b) For the distance measurements: $\pm 1 \times 10^{-1}$ m.

A display of the measured speed or the difference between the measured speed and the reference speed for the test can be used inside the vehicle so that the driver can adjust the speed of the vehicle.

A data acquisition system can be also used for storing the measurements.

3.12.3.2.2.2. Test procedure

Starting with a defined initial speed, the brakes are applied hard enough on the two axles at the same time to activate the ABS system.

3.12.3.2.2.2.1. The Average Deceleration (AD) is calculated between two defined speeds, with an initial speed of 60 km/h and a final speed of 20 km/h.

3.12.3.2.2.2.2. Vehicle equipment

The rear axle may be indifferently fitted with 2 or 4 tyres.

For the reference tyre testing, both axles are fitted with reference tyres. (A total of 4 or 6 reference tyres depending on the choice above mentioned).

For the candidate tyre testing, 3 fitting configurations are possible:

- (a) Configuration "Configuration 1": Candidate tyres on front and rear axles: it is the standard configuration that should be used every time it is possible.
- (b) Configuration "Configuration 2": Candidate tyres on front axle and reference tyre or control tyre on rear axle: allowed in such cases where fitting the candidate tyre on the rear position is not possible.
- (c) Configuration "Configuration 3": Candidate tyres on rear axle and reference tyre or control tyre on front axle: permitted in such cases where fitting the candidate tyre on the front position is not possible.

3.12.3.2.2.2.3. Tyre inflation pressure

- (a) For a vertical load higher or equal to 75 per cent of the maximum load rating of the tyre, the test inflation pressure "P_t" shall be calculated as follows:

$$P_t = P_r \left(\frac{Q_t}{Q_r} \right)^{1.25}$$

P_r is the Reference Test Inflation Pressure.

Q_t = The static test load of the tyre

Q_r = The maximum load rating of the tyre

- (b) For a vertical load lower than 75 per cent of the maximum load rating of the tyre, the test inflation pressure P_t shall be calculated as follows:

$$P_t = P_r (0.75)^{1.25} = (0.7) P_r$$

P_r Is the Reference Test Inflation Pressure.

Check the tyre pressure just prior to testing at ambient temperature.

3.12.3.2.2.2.4. Tyre load

The static load on each axle shall remain the same throughout the test procedure. The static load on each tyre shall lie between 60 per cent and 100 per cent maximum load rating of the candidate tyre's. This value shall not exceed 100 per cent of the maximum load rating of the reference tyre.

Tyre load on the same axle should not differ by more than 10 per cent.

The use of fitting as per Configuration 2 and Configuration 3 shall fulfil the following additional requirements:

Configuration 2: Front axle load > Rear axle load

The rear axle may be indifferently fitted with 2 or 4 tyres

Configuration 3: Rear axle load > Front axle load 1.8

3.12.3.2.2.2.5. Tyre preparation and break-in

- 3.12.3.2.2.2.5.1. Mount the tyre on a test rim with a width comprised between the minimum and maximum width as per Annex 9. The rim contour shall be one of those specified for the fitment of the test tyre.

Ensure proper bead seating by the use of a suitable lubricant. Excessive use of lubricant should be avoided to prevent slipping of the tyre on the wheel rim.

- 3.12.3.2.2.2.5.2. Place the fitted test tyres in a location for a minimum of two hours such that they all have the same ambient temperature prior to testing and shield them from the sun to avoid excessive heating by solar radiation. For tyre break-in, perform two braking runs.
- 3.12.3.2.2.2.5.3. Condition the pavement by conducting at least ten test runs with tyres not involved in the test programme at an initial speed higher or equal to 65 km/h (which is higher than the initial test speed to guarantee that a sufficient length of track is conditioned).

3.12.3.2.2.2.6. Procedure

- 3.12.3.2.2.2.6.1. First, mount the set of reference tyres on the vehicle.

The vehicle accelerates in the starting zone up to (65 ± 2) km/h.

Activation of the brakes on the track is made always at the same place with a tolerance of 5 meters in longitudinal and 0.5 meter in transverse.

- 3.12.3.2.2.2.6.2. According to the type of transmission, two cases are possible:

(a) Manual transmission

As soon as the driver is in the measuring zone and having reached (65 ± 2) km/h, the clutch is released, and the brake pedal depressed sharply, holding it down as long as necessary to perform the measurement.

(b) Automatic transmission

As soon as the driver is in the measuring zone and having reached (65 ± 2) km/h, select neutral gear and then the brake pedal is depressed sharply, holding it down as long as necessary to perform the measurement.

Automatic activation of the brakes can be performed by means of a detection system made of two parts, one indexed to the track and one embarked on the vehicle. In that case braking is made more rigorously at the same portion of the track.

If any of the above-mentioned conditions are not met when a measurement is made (speed tolerance, braking time, etc.), the measurement is discarded, and a new measurement is made.

- 3.12.3.2.2.2.6.3. Test running order

Examples:

The run order for a test of 3 sets of candidate tyres (T1 to T3) plus a reference tyre R would be:

R – T1 – T2 – T3 – R

The run order for a test of 5 sets of tyres (T1 to T5) plus a reference tyre R would be:

R – T1 – T2 – T3 – R – T4 – T5 – R

- 3.12.3.2.2.2.6.4. The direction of the test shall be the same for each set of tests and shall be the same for the candidate test tyre as that used for the SRTT with which its performance is to be compared.
- 3.12.3.2.2.2.6.5. For each test and for new tyres, the first two braking measurements are discarded.
- 3.12.3.2.2.2.6.6. After at least 3 valid measurements have been made in the same direction, the reference tyres are replaced by a set of the candidate tyres (one of the 3 configurations presented in paragraph 3.12.3.2.2.2.2.) and at least 6 valid measurements shall be performed.
- 3.12.3.2.2.2.6.7. A maximum of three sets of candidate tyres can be tested before the reference tyre is re-tested.

3.12.3.2.2.2.7. Processing of measurement results

3.12.3.2.2.2.7.1. Calculation of the Average Deceleration (AD)

Each time the measurement is repeated, the average deceleration AD (m·s⁻²) is calculated by:

$$AD = \left| \frac{S_f^2 - S_i^2}{2d} \right|$$

Where d (m) is the distance covered between the initial speed S_i (m·s⁻¹) and the final speed S_f (m·s⁻¹).

3.12.3.2.2.2.7.2. Validation of results

For the reference tyre:

If the coefficient of variation of "AD" of any two consecutive groups of 3 runs of the reference tyre is higher than 3 per cent, discard all data and repeat the test for all tyres (the candidate tyres and the reference tyre). The coefficient of variation is calculated by the following relation:

$$\frac{\text{standard deviation}}{\text{average}} \times 100$$

For the candidate tyres:

The coefficients of variation are calculated for all the candidate tyres.

$$\frac{\text{standard deviation}}{\text{average}} \times 100$$

If one coefficient of variation is greater than 3 per cent, discard the data for this candidate tyre and repeat the test.

3.12.3.2.2.2.7.3. Calculation of the "average AD"

If R1 is the average of the AD values in the first test of the reference tyre and R2 is the average of the AD values in the second test of the reference tyre, the following operations are performed, according to the following table.

Ra is the adjusted average AD of the reference tyre

Table 36

"Ra" calculation

<i>Number of sets of candidate tyres between two successive runs of the reference tyre</i>	<i>Set of candidate tyres to be qualified</i>	<i>Ra</i>
1 R1 – T1 – R2	T1	$Ra = 1/2 (R1 + R2)$
2 R1 – T1 – T2 – R2	T1	$Ra = 2/3 R1 + 1/3 R2$
	T2	$Ra = 1/3 R1 + 2/3 R2$
3 R1 – T1 – T2 – T3 – R2	T1	$Ra = 3/4 R1 + 1/4 R2$
	T2	$Ra = 1/2 (R1 + R2)$
	T3	$Ra = 1/4 R1 + 3/4 R2$

3.12.3.2.2.2.7.4. Calculation of braking force coefficient, BFC

BFC(R) and BFC(T) are calculated according to the following table:

Table 37

Braking force coefficient calculation

<i>Tyre type</i>	<i>Braking force coefficient is</i>
Reference tyre	$BFC(R) = Ra/g$
Candidate tyre	$BFC(T) = Ta/g$
g is the acceleration due to gravity (rounded to 9.81 m·s ⁻²).	

Ta (a = 1, 2, etc.) is the average of the AD values for a test of a candidate tyre.

3.12.3.2.2.2.7.5. Calculation of the relative wet grip performance index of the tyre

The Wet grip index represents the relative performance of the candidate tyre compared to the reference tyre. The way to obtain it depends on the test configuration as defined in paragraph 3.12.3.2.2.2. The wet grip index of the tyre is calculated as reported into the following table:

Table 38

Wet grip index calculation

Configuration 1: candidate tyres on both axles	$Wet\ Grip\ Index = \frac{BFC(T)}{BFC(R)}$
Configuration 2: candidate tyres on front axle and reference tyres on rear axle	$Wet\ Grip\ Index = \frac{(BFC(T) \cdot [a + b + h \cdot BFC(R)] - a \cdot BFC(R))}{BFC(R) \cdot [b + h \cdot BFC(T)]}$
Configuration 3: reference tyres on front axle and candidate tyres on rear axle	$Wet\ Grip\ Index = \frac{(BFC(T) \cdot [-a - b + h \cdot BFC(R)] + b \cdot BFC(R))}{BFC(R) \cdot [-a + h \cdot BFC(T)]}$

Where:

- "G": centre of gravity of the loaded vehicle;
- "m": mass (in kilograms) of the loaded vehicle;
- "a": horizontal distance between front axle and centre of gravity of the loaded vehicle (m);
- "b": horizontal distance between rear axle and centre of gravity of the loaded vehicle;
- "h": vertical distance between ground level and centre of gravity of the loaded vehicle (m);
- N.B.* When "h" is not precisely known, these worst-case values shall apply: 1.2 for configuration 2, and 1.5 for configuration 3
- " γ " loaded vehicle acceleration ($m \cdot s^{-2}$);
- "g" acceleration due to the gravity ($m \cdot s^{-2}$);
- "X1" longitudinal (X-direction) reaction of the front tyre on the road;
- "X2" longitudinal (X-direction) reaction of the rear tyre on the road;
- "Z1" normal (Z-direction) reaction of the front tyre on the road;
- "Z2" normal (Z-direction) reaction of the rear tyre on the road;

Figure 6

Nomenclature explanation related to grip index of the tyre

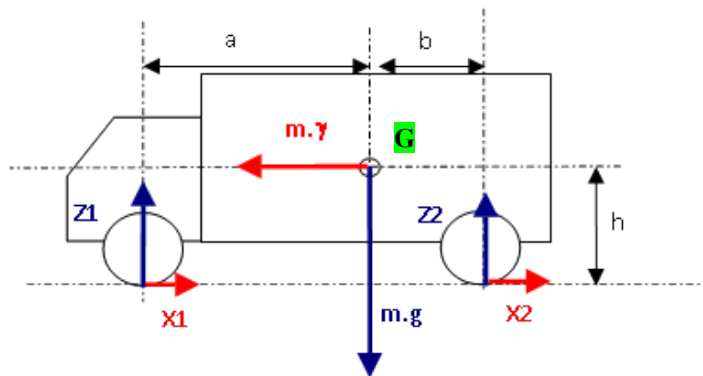

3.12.3.2.2.2.8. Wet grip performance comparison between a candidate tyre and a reference tyre using a control tyre

When the candidate tyre size is significantly different from the reference tyre, a direct comparison on the same vehicle may be not possible. This approach uses an intermediate tyre, hereinafter called the control tyre.

3.12.3.2.2.2.8.1. The principle lies upon the use of a control tyre and 2 different vehicles for assessing a candidate tyre in comparison with a reference tyre.

One vehicle can fit the reference tyre and the control tyre, the other the control tyre and the candidate tyre. All conditions are in conformity with paragraphs 3.12.3.2.2.2.1, to 3.12.3.2.2.2.5, above.

3.12.3.2.2.2.8.2. The first assessment is a comparison between the control tyre and the reference tyre. The result (Wet Grip Index 1) is the relative efficiency of the control tyre compared to the reference tyre.

3.12.3.2.2.2.8.3. The second assessment is a comparison between the candidate tyre and the control tyre. The result (Wet Grip Index 2) is the relative efficiency of the candidate tyre compared to the control tyre.

The second assessment is done on the same track as the first one and within one week maximum. The wetted surface temperature shall be in the range of $\pm 5^{\circ}\text{C}$ of the temperature of the first assessment. The control tyre set (4 or 6 tyres) is physically the same set as the set used for the first assessment.

3.12.3.2.2.2.8.4. The wet grip index of the candidate tyre compared to the reference tyre is deduced by multiplying the relative efficiencies calculated above:

(Wet Grip Index 1 \times Wet Grip Index 2)

Note: When the test expert decides to use an SRTT tyre as a control tyre (i.e. in the test procedure two SRTTs are compared directly instead of an SRTT with a control tyre) the result of the comparison between the SRTTs is called the "local shift factor".

It is permitted to use a previous SRTTs comparison.

The comparison results shall be checked periodically.

3.12.3.2.2.2.8.5. Selection of a set of tyres as a control tyre set

A "control tyre" set is a group of identical tyres made in the same factory during a one-week period.

3.12.3.2.2.2.8.6. Reference and control tyres

Before the first assessment (control tyre / reference tyre), normal storage conditions can be used. It is necessary that all the tyres of a control tyre set have been stored in the same conditions.

3.12.3.2.2.2.8.7. Storage of control tyres

As soon as the control tyre set has been assessed in comparison with the reference tyre, specific storage conditions shall be applied for control tyres replacement.

3.12.3.2.2.2.8.8. Replacement of reference and control tyres

When irregular wear or damage results from tests, or when wear influences the test results, the use of the tyre shall be discontinued.

3.13. Rolling resistance test

3.13.1. Requirements

The following requirements does not apply to professional off-road tyres, tyres fitted with additional devices to improve traction properties (e.g. studded tyres), tyres with a speed rating less than 80 km/h (speed symbol F) and those having a nominal rim diameter code ≤ 10 (or ≤ 254 mm) or ≥ 25 (or ≥ 635 mm).

3.13.1.1. The maximum values for the rolling resistance coefficient shall not exceed the following (value in N/kN is equivalent to value in kg/tonne):

Table 39

Maximum rolling resistance coefficient value

<i>Tyre class</i>	<i>Max value (N/kN)</i>
C1	10.5
C2	9.0
C3	6.5

For "snow tyre for use in severe snow conditions", the limits shall be increased by 1 N/kN.

3.13.2. Test Methods

The alternative measurement methods listed below are given in this Regulation. The choice of an individual method is left to the tester. For each method, the test measurements shall be converted to a force acting at the tyre/drum interface. The measured parameters are:

- (a) In the force method: the reaction force measured or converted at the tyre spindle¹⁷;
- (b) In the torque method: the torque input measured at the test drum¹⁸;
- (c) In the deceleration method: the measurement of deceleration of the test drum and tyre assembly¹⁸.
- (d) In the power method: the measurement of the power input to the test drum¹⁸.

3.13.3. Test Equipment

3.13.3.1. Drum specifications

3.13.3.1.1. Diameter

The test dynamometer shall have a cylindrical flywheel (drum) with a diameter of at least 1.7 m.

The F_r and C_r values shall be expressed relative to a drum diameter of 2.0 m. If drum diameter different than 2.0 m is used, a correlation adjustment shall be made following the method in paragraph 3.13.7.3.

3.13.3.1.2. Surface

The surface of the drum shall be smooth steel. Alternatively, in order to improve skim test reading accuracy, a textured surface may also be used, which should be kept clean.

The F_r and C_r values shall be expressed relative to the "smooth" drum surface. If a textured drum surface is used, see Annex 8, paragraph 7.

3.13.3.1.3. Width

The width of the drum test surface shall exceed the width of the test tyre contact patch.

3.13.3.2. Test rim

¹⁷ This measured value also includes the bearing and aerodynamic losses of the wheel and tyre which are also to be considered for further data interpretation.

¹⁸ The measured value in the torque, deceleration and power methods also includes the bearing and aerodynamic losses of the wheel, the tyre, and the drum which are also to be considered for further data interpretation.

The tyre shall be mounted on a steel or light alloy test rim, with a width corresponding to the measuring rim width code as per Annex 9, except for sizes listed in Annex 6, in which case the width of the test rim to be used is the one indicated in the column "measuring rim width code".

The rim contour shall be one of those specified for the fitment of the test tyre.

3.13.3.3. Load, alignment, control and instrumentation accuracies

Measurement of these parameters shall be sufficiently accurate and precise to provide the required test data. The specific and respective values are shown in Annex 8.

3.13.3.4. Thermal environment

3.13.3.4.1. Reference conditions

The reference ambient temperature, measured at a distance not less than 0.15 m and not more than 1 m from the tyre sidewall, shall be 25 °C.

3.13.3.4.2. Alternative conditions

If the test ambient temperature is different from the reference ambient temperature, the rolling resistance measurement shall be corrected to the reference ambient temperature in accordance with paragraph 3.13.7.2. of this Regulation.

3.13.3.4.3. Drum surface temperature.

Care should be taken to ensure that the temperature of the test drum surface is the same as the ambient temperature at the beginning of the test.

3.13.4. Test Conditions

3.13.4.1. General

The test consists of a measurement of rolling resistance in which the tyre is inflated, and the inflation pressure allowed to build up, i.e., "capped air".

3.13.4.2. Test speeds

The value shall be obtained at the appropriate drum speed specified in Table 40.

Table 40

Test Speeds (in km/h)

<i>Tyre Class</i>	<i>C1</i>	<i>C2 and C3</i>	<i>C3</i>	
Load Index	All	LI ≤ 121	LI > 121	
Speed Symbol	All	All	J 100 km/h and lower or tyres not marked with speed symbol	K 110 km/h and higher
Speed	80	80	60	80

3.13.4.3. Test load

The standard test load shall be computed from the values shown in Table 41 and shall be kept within the tolerance specified in Annex 8.

3.13.4.4. Test inflation pressure

The inflation pressure shall be in accordance with that shown in Table 41 and shall be capped with the accuracy specified in paragraph 4. of Annex 8.

Table 41
Test Loads and Inflation Pressures

Tyre Class	C1 ^(a)		C2, C3
	Standard Load	Extra Load	
Test Load (% of the maximum load rating)	80	80	85 ^(b) (% of single load)
Test Inflation Pressure kPa	210	250	Reference Test Inflation Pressure

Note: The inflation pressure shall be capped with the accuracy specified in paragraph 4 of Annex 8.

^(a) For those passenger car tyres belonging to categories which are not shown in ISO 4000-1:2010, the inflation pressure shall be the inflation pressure recommended by the tyre manufacturer, corresponding to the maximum load rating, reduced by 30 kPa.

^(b) As a percentage of single load, or 85 per cent of maximum load rating for single application specified in applicable tyre standards manuals if not marked on tyre.

3.13.4.5. Duration and speed.

When the deceleration method is selected, the following requirements apply:

- (a) The deceleration j shall be determined in differential $d\omega/dt$ or discrete $\Delta\omega/\Delta t$ form, where ω is angular velocity, t – time;
If the differential form $d\omega/dt$ is used, then the recommendations of Annex 10 are to be applied.
- (b) For duration Δt , the time increments shall not exceed 0.5 s;
- (c) Any variation of the test drum speed shall not exceed 1 km/h within one time increment.

3.13.5. Test Procedure

3.13.5.1. General

The test procedure steps described below shall be followed in the sequence given.

3.13.5.2. Thermal conditioning

The inflated tyre shall be placed in the thermal environment of the test location for a minimum of:

- (a) 3 hours for Class C1 tyres;
- (b) 6 hours for Class C2 and Class C3 tyres.

3.13.5.3. Pressure adjustment

After thermal conditioning, the inflation pressure shall be adjusted to the test inflation pressure, and verified 10 minutes after the adjustment is made.

3.13.5.4. Warm-up

The warm-up durations shall be as specified in Table 42

Table 42
Warm Up Durations

Tyre Class	C1	C2 and C3 $LI \leq 121$	C3 $LI > 121$	
			< 22.5	≥ 22.5
Nominal Rim Diameter	All	All	< 22.5	≥ 22.5
Warm up duration	30 min.	50 min.	150 min.	180 min.

3.13.5.5. Measurement and recording

The following shall be measured and recorded (see Figure 10):

- (a) Test speed U_n ;
- (b) Load on the tyre normal to the drum surface L_m ;
- (c) The initial test inflation pressure as defined in paragraph 3.13.4.3.;
- (d) The coefficient of rolling resistance measured C_r , and its corrected value C_{re} , at 25 °C and for a drum diameter of 2.0 m;
- (e) The distance from the tyre axis to the drum outer surface under steady state r_L ;
- (f) Ambient temperature t_{amb} ;
- (g) Test drum radius R ;
- (h) Test method chosen;
- (i) Test rim (size and material);
- (j) Tyre size, manufacturer, type, identity number (if one exists), speed symbol, load index, TIN (Tyre Identification Number)

Figure 10

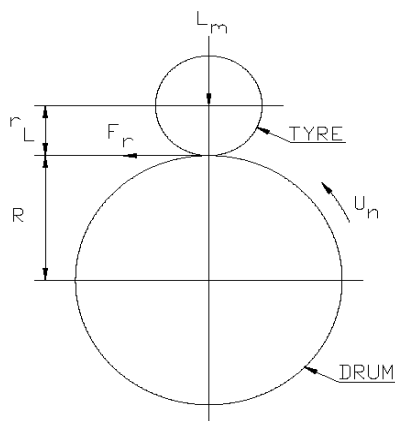

All the mechanical quantities (forces, torques) will be orientated in accordance with the axis systems specified in ISO 8855:1991.

The directional tyres shall be run in their specified rotation sense.

- 3.13.5.6. Measurement of parasitic losses
- The parasitic losses shall be determined by one of the following procedures given in paragraph 3.13.5.6.1. or 3.13.5.6.2.
- 3.13.5.6.1. Skim test reading
- Skim test reading follows the procedure below:
- (a) Reduce the load to maintain the tyre at the test speed without slippage¹⁹.
- The load values should be as follows:
- (i) Class C1 tyres: recommended value of 100 N; not to exceed 200 N;
- (ii) Class C2 tyres: recommended value of 150 N; not to exceed 200 N for machines designed for Class C1 tyres measurement or 500 N for machine designed for Class C2 and Class C3 tyres;
- (iii) Class C3 tyres: recommended value of 400 N; not to exceed 500 N.
- (b) Record the spindle force F_b , input torque T_b , or the power, whichever applies¹⁶;
- (c) Record the load on the tyre normal to the drum surface L_m ¹⁶.
- 3.13.5.6.2. Deceleration method
- The deceleration method follows the procedure below:
- (a) Remove the tyre from the test surface;
- (b) Record the deceleration of the test drum $\Delta\omega_{D0}/\Delta t$ and that of the unloaded tyre $\Delta\omega_{T0}/\Delta t$ ¹⁶ or record the deceleration of the test drum j_{D0} and that of the unloaded tyre j_{T0} in exact or approximate form in accordance with paragraph 3.13.4.5.
- 3.13.5.7. Allowance for machines exceeding σ_m criterion
- The steps described in paragraphs 3.13.5.3. to 3.13.5.5. shall be carried out once only, if the measurement standard deviation determined in accordance with paragraph 3.13.7.5. is:
- (a) Not greater than 0.075 N/kN for Class C1 and Class C2 tyres;
- (b) Not greater than 0.06 N/kN for Class C3 tyres.
- If the measurement standard deviation exceeds this criterion, the measurement process will be repeated n times as described in paragraph 3.13.7.5. The rolling resistance value reported shall be the average of the n measurements.

¹⁹ With the exception of the force method, the measured value includes the bearing and aerodynamic losses of the wheel, the tyre, and the drum losses which also need to be considered. It is known that the spindle and drum bearing frictions depend on the applied load. Consequently, it is different for the loaded system measurement and the skim test reading. However, for practical reasons, this difference can be disregarded.

3.13.6. Data interpretation

3.13.6.1. Determination of parasitic losses

3.13.6.1.1. General

The laboratory shall perform the measurements described in paragraph 3.13.5.6.1. for the force, torque and power methods or those described in paragraph 3.13.5.6.2. for the deceleration method, in order to determine precisely in the test conditions (load, speed, temperature) the tyre spindle friction, the tyre and wheel aerodynamic losses, the drum (and as appropriate, engine and/or clutch) bearing friction, and the drum aerodynamic losses.

The parasitic losses related to the tyre/drum interface F_{pl} expressed in newtons shall be calculated from the force F_t torque, power or the deceleration, as shown in paragraphs 3.13.6.1.2. to 3.13.6.1.5. below.

3.13.6.1.2. Force method at tyre spindle

Calculate: $F_{pl} = F_t \left(1 + r_L/R\right)$

Where:

F_t is the tyre spindle force in newtons (see paragraph 3.13.5.6.1.),

r_L is the distance from the tyre axis to the drum outer surface under steady state conditions, in meters,

R is the test drum radius, in meters.

3.13.6.1.3. Torque method at drum axis

Calculate: $F_{pl} = T_t/R$

Where:

T_t is the input torque in newtons meters, as determined in paragraph 3.13.5.6.1.

R is the test drum radius, in meters.

3.13.6.1.4. Power method at drum axis

Calculate:

$$F_{pl} = \frac{3.6 V \cdot A}{U_n}$$

Where:

V is the electrical potential applied to the machine drive, in volts,

A is the electric current drawn by the machine drive, in amperes,

U_n is the test drum speed, in kilometers per hour.

3.13.6.1.5. Deceleration method

Calculate the parasitic losses F_{pl} , in newtons.

$$F_{pl} = \frac{I_D}{R} \left(\frac{\Delta\omega_{D0}}{\Delta t_0} \right) + \frac{I_T}{R_r} \left(\frac{\Delta\omega_{T0}}{\Delta t_0} \right)$$

Where:

- I_D is the test drum inertia in rotation, in kilograms meter squared,
- R is the test drum surface radius, in meters,
- ω_{D0} is the test drum angular speed, without tyre, in radians per second,
- Δt_0 is the time increment chosen for the measurement of the parasitic losses without tyre, in seconds,
- I_T is the spindle, tyre and wheel inertia in rotation, in kilograms meter squared,
- R_r is the tyre rolling radius, in meters,
- ω_{T0} is the tyre angular speed, unloaded tyre, in radians per second.

or

$$F_{pl} = \frac{I_D}{R} j_{D0} + \frac{I_T}{R_r} j_{T0}$$

Where:

- I_D is the test drum inertia in rotation, in kilograms meter squared,
- R is the test drum surface radius, in meters,
- j_{D0} is the deceleration of the test drum, without tyre, in radians per second squared,
- I_T is the spindle, tyre and wheel inertia in rotation, in kilograms meter squared,
- R_r is the tyre rolling radius, in meters,
- j_{T0} is the deceleration of unloaded tyre, in radians per second squared."

3.13.6.2. Rolling resistance calculation

3.13.6.2.1. General

The rolling resistance F_r , expressed in newtons, is calculated using the values obtained by testing the tyre to the conditions specified in paragraphs 3.13.4 and by subtracting the appropriate parasitic losses F_{pl} , obtained according to paragraph 3.13.6.1.

3.13.6.2.2. Force method at tyre spindle

The rolling resistance F_r , in newtons, is calculated using the equation

$$F_r = F_t [1 + (r_L/R)] - F_{pl}$$

Where:

- F_t is the tyre spindle force in newtons,
- F_{pl} represents the parasitic losses as calculated in paragraph 3.13.6.1.2.,
- r_L is the distance from the tyre axis to the drum outer surface under steady-state conditions, in meters,
- R is the test drum radius, in meters.

3.13.6.2.3. Torque method at drum axis

The rolling resistance F_r , in newtons, is calculated with the equation

$$F_r = \frac{T_t}{R} - F_{pl}$$

Where:

T_t is the input torque, in newton meters,

F_{pl} represents the parasitic losses as calculated in paragraph 3.13.6.1.3.,

R is the test drum radius, in meters.

3.13.6.2.4. Power method at drum axis

The rolling resistance F_r , in newtons, is calculated with the equation:

$$F_r = \frac{3.6V \cdot A}{U_n} - F_{pl}$$

Where:

V = is the electrical potential applied to the machine drive, in volts,

A = is the electric current drawn by the machine drive, in amperes,

U_n = is the test drum speed, in kilometers per hour,

F_{pl} = represents the parasitic losses as calculated in paragraph 3.13.6.1.4.

3.13.6.2.5. Deceleration method

The rolling resistance F_r , in newtons, is calculated using the equation:

$$F_r = \frac{I_D}{R} \left(\frac{\Delta\omega_V}{\Delta t_V} \right) + \frac{R I_T}{R_r^2} \left(\frac{\Delta\omega_V}{\Delta t_V} \right) - F_{pl}$$

Where:

I_D is the test drum inertia in rotation, in kilograms meter squared,

R is the test drum surface radius, in meters,

F_{pl} represents the parasitic losses as calculated in paragraph 3.13.6.1.5.,

Δt_V is the time increment chosen for measurement, in seconds,

$\Delta\omega_V$ is the test drum angular speed increment, without tyre, in radians per second,

I_T is the spindle, tyre and wheel inertia in rotation, in kilograms meter squared,

R_r is the tyre rolling radius, in meters,

F_r is the rolling resistance, in newtons.

or

$$F_r = \frac{I_D}{R} j_V + \frac{R I_T}{R_r^2} j_V - F_{pl}$$

Where:

- I_D is the test drum inertia in rotation, in kilograms meter squared,
 R is the test drum surface radius, in meters,
 F_{pl} represents the parasitic losses as calculated in paragraph 3.13.6.1.5.,
 j_V is the deceleration of the test drum, in radians per second squared,
 I_T is the spindle, tyre and wheel inertia in rotation, in kilograms meter squared,
 R_r is the tyre rolling radius, in meters,
 F_r is the rolling resistance, in newtons.

3.13.7. Data Analysis

3.13.7.1. Rolling resistance coefficient

The rolling resistance coefficient C_r is calculated by dividing the rolling resistance by the load on the tyre:

$$C_r = \frac{F_r}{L_m}$$

Where:

F_r is the rolling resistance, in newtons,

L_m is the test load, in kilonewtons.

3.13.7.2. Temperature correction

If measurements at temperatures other than 25 °C are unavoidable (only temperatures not less than 20 °C or more than 30 °C are acceptable), then a correction for temperature shall be made using the following equation:

$$F_{r25} = F_r [1 + K(t_{amb} - 25)]$$

Where:

F_{r25} is the rolling resistance at 25 °C, in newtons,

F_r is the rolling resistance, in newtons,

t_{amb} is the ambient temperature, in degrees Celsius,

K is equal to:

0.008 for Class C1 tyres

0.010 for Class C2 and Class C3 tyres with a load index equal or lower than 121

0.006 for Class C3 tyres with a load index greater than 121"

3.13.7.3. Drum diameter correction

Test results obtained from different drum diameters shall be compared by using the following theoretical formula:

$$F_{r02} \cong KF_{r01}$$

with:

$$K = \sqrt{\frac{(R_1/R_2)(R_2 + r_T)}{(R_1 + r_T)}}$$

Where:

R_1 is the radius of drum 1, in meters,

R_2 is the radius of drum 2, in meters,

r_T is one-half of the nominal design tyre diameter, in meters,

$F_{r,01}$ is the rolling resistance value measured on drum 1, in newtons,

$F_{r,02}$ is the rolling resistance value measured on drum 2, in newtons.

3.13.7.4. Measurement result

Where n measurements are greater than 1, if required by paragraph 3.13.5.6., the measurement result shall be the average of the C_T values obtained for the n measurements, after the corrections described in paragraphs 3.13.7.2. and 3.13.7.3. have been made.

3.13.7.5. The laboratory shall ensure that, based on a minimum of three measurements, the machine maintains the following values of σ_m , as measured on a single tyre:

$\sigma_m \leq 0.075$ N/kN for Class C1 and Class C2 tyres

$\sigma_m \leq 0.06$ N/kN for Class C3 tyres

If the above requirement for σ_m is not met, the following formula shall be applied to determine the minimum number of measurements n (rounded to the immediate superior integer value) that are required by the machine to qualify for conformance with this Regulation.

$$n = (\sigma_m / x)^2$$

Where:

$x = 0.075$ N/kN for Class C1 and Class C2 tyres

$x = 0.06$ N/kN for Class C3 tyres

If a tyre needs to be measured several times, the tyre/wheel assembly shall be removed from the machine between the successive measurements.

If the removal/refitting operation duration is less than 10 minutes, the warm-up durations indicated in paragraph 3.13.5.3. may be reduced to:

- (a) 10 minutes for Class C1 tyres;
- (b) 20 minutes for Class C2 tyres;
- (c) 30 minutes for Class C3 tyres.

3.13.7.6. Monitoring of the laboratory control tyre shall be carried out at intervals no greater than one month. Monitoring shall include a minimum of 3 separate measurements taken during this one-month period. The average of the 3 measurements taken during a given one-month period shall be evaluated for drift from one monthly evaluation to another.

3.14. Snow performance test relative to snow tyre for use in severe snow conditions

In order to be classified as a "snow tyre for use in severe snow conditions" the tyre shall meet the performance requirements of paragraph 3.14.1. The tyre shall meet these requirements based on a test method by which:

- (a) the mean fully developed deceleration ("mfdd") in a braking test;
- (b) or alternatively an average traction force in a spin traction test;
- (c) or alternatively the average acceleration in an acceleration test;

of the candidate tyre is compared to that of a standard reference tyre.

The relative performance shall be indicated by a snow index.

3.14.1. Tyre snow performance requirements

The following requirements does not apply to professional off-road tyres, tyres fitted with additional devices to improve traction properties (e.g. studded tyres), tyres with a speed rating less than 80 km/h (speed symbol F) and those having a nominal rim diameter code ≤ 10 (or ≤ 254 mm) or ≥ 25 (or ≥ 635 mm).

3.14.1.1. Class C1, Class C2 and Class C3 tyres

The minimum snow index value, as calculated in the procedure described in this paragraph for the different class of tyres, shall be as follows:

Table 43

Minimum snow grip index

Class of tyre	Snow grip index (brake on snow method) (a)		Snow grip index (spin traction method) (b)	Snow grip index (acceleration method) (c)
	Ref. = C1 – SRTT 14	Ref. = C2 – SRTT 16C	Ref. = C1 – SRTT 14	Ref. = C3N – SRTT 19.5 Ref. = C3W – SRTT 22.5
C1	1.07	No	1.10	No
C2	No	1.02	1.10	No
C3	No	No	No	1.25

- (a) See paragraph 3.14.3.
- (b) See paragraph 3.14.2.
- (c) See paragraph 3.14.4.

3.14.2. Spin traction method for Class C1 and Class C2 tyres (traction force test).

The test procedure of ASTM standard F1805-06 shall be used to assess snow performance through spin traction values on medium packed snow (The snow compaction index measured with a CTI penetrometer²⁰ shall be between 70 and 80).

3.14.2.1. The test course surface shall be composed of a medium packed snow surface, as characterized in table A2.1 of ASTM standard F1805-06.

3.14.2.2. The tyre load for testing shall be as per option 2 in paragraph 11.9.2. of ASTM standard F1805-06.

²⁰ See appendix of ASTM standard F1805-06 for details.

3.14.3. Braking on snow method for Class C1 and Class C2 tyres

3.14.3.1. General conditions

3.14.3.1.1. Test course

The braking tests shall be done on a flat test surface of sufficient length and width, with a maximum 2 per cent gradient, covered with packed snow.

The snow surface shall be composed of a hard packed snow base at least 3 cm thick and a surface layer of medium packed and prepared snow about 2 cm thick.

The air temperature, measured about one meter above the ground, shall be between -2°C and 15°C ; the snow temperature, measured at a depth of about one centimeter, shall be between -4°C and -15°C .

It is recommended to avoid direct sunlight, large variations of sunlight or humidity, as well as wind.

The snow compaction index measured with a CTI penetrometer¹⁷ shall be between 75 and 85.

3.14.3.1.2. Vehicle

The test shall be conducted with a standard production vehicle in good running order and equipped with an ABS system.

The vehicle used shall be such that the loads on each wheel are appropriate to the tyres being tested. Several different tyre sizes can be tested on the same vehicle.

3.14.3.1.3. Tyres

The tyres should be "broken-in" prior to testing to remove spew, compound nodules or flashes resulting from the moulding process. The tyre surface in contact with snow shall be cleaned before performing a test.

Tyres shall be conditioned at the outdoor ambient temperature at least two hours before their mounting for tests. Tyre pressures shall then be adjusted to the values specified for the test.

In case a vehicle cannot accommodate both the reference and candidate tyres, a third tyre ("control" tyre) may be used as an intermediate. First test control vs. reference on another vehicle, then test candidate vs. control on the vehicle.

3.14.3.1.4. Load and pressure:

3.14.3.1.4.1. For Class C1 tyres, the vehicle load shall be such that the resulting loads on the tyres are between 60 per cent and 90 per cent of the maximum load rating.

The cold inflation pressure shall be 240 kPa.

3.14.3.1.4.2. For Class C2 tyres, the vehicle load shall be such that the resulting loads on the tyres are between 60 per cent and 100 per cent of the maximum load rating in single application.

The static tyre load on the same axle should not differ by more than 10 per cent.

The inflation pressure is calculated to run at constant deflection:

For a vertical load higher or equal to 75 per cent of the **maximum load rating** of the tyre, a constant deflection is applied, hence the test inflation pressure P_t shall be calculated as follows:

$$P_t = P_r \left(\frac{Q_t}{Q_r} \right)^{1.25}$$

Q_r is the maximum **load rating**.

P_r is **the Reference Test Inflation Pressure**

Q_t is the static test load of the tyre

For a vertical load lower than 75 per cent of the **maximum load rating** of the tyre, a constant inflation pressure is applied, hence the test inflation pressure P_t shall be calculated as follows:

$$P_t = P_r (0.75)^{1.25} = (0.7)P_r$$

P_r is the **Reference Test Inflation Pressure**

Check the tyre pressure just prior to testing at ambient temperature."

3.14.3.1.5. Instrumentation

The vehicle shall be fitted with calibrated sensors suitable for measurements in winter. There shall be a data acquisition system to store measurements.

The accuracy of measurement sensors and systems shall be such that the relative uncertainty of the measured or computed mean fully developed decelerations is less than 1 per cent.

3.14.3.2. Testing sequences

3.14.3.2.1. For every candidate tyre and the standard reference tyre, ABS-braking test runs shall be repeated a minimum of 6 times.

The zones where ABS-braking is fully applied shall not overlap.

When a new set of tyres is tested, the runs are performed after shifting aside the vehicle trajectory in order not to brake on the tracks of the previous tyre.

When it is no longer possible not to overlap full ABS-braking zones, the test course shall be re-groomed.

Required sequence:

6 repeats SRTT, then shift aside to test next tyre on fresh surface

6 repeats Candidate 1, then shift aside

6 repeats Candidate 2, then shift aside

6 repeats SRTT, then shift aside

3.14.3.2.2. Order of testing:

If only one candidate tyre is to be evaluated, the order of testing shall be:

R1 – T – R2

Where:

R1 is the initial test of the SRTT,

R2 is the repeat test of the SRTT and

T is the test of the candidate tyre to be evaluated.

A maximum of two candidate tyres may be tested before repeating the SRTT test, for example:

R1 – T1 – T2 – R2.

3.14.3.2.3. The comparative tests of SRTT and candidate tyres shall be repeated on two different days.

3.14.3.3. Test procedure

3.14.3.3.1. Drive the vehicle at a speed not lower than 28 km/h.

3.14.3.3.2. When the measuring zone has been reached, the vehicle gear is set into neutral, the brake pedal is depressed sharply by a constant force sufficient to cause operation of the ABS on all wheels of the vehicle and to result in stable deceleration of the vehicle and held down until the speed is lower than 8 km/h.

3.14.3.3.3. The mean fully developed deceleration between 25 km/h and 10 km/h shall be computed from time, distance, speed, or acceleration measurements.

3.14.3.4. Data evaluation and presentation of results

3.14.3.4.1. Parameters to be reported

3.14.3.4.1.1. For each tyre and each braking test, the mean and standard deviation of the mfdd shall be computed and reported.

The coefficient of variation CV of a tyre braking test shall be computed as:

$$CV(\text{tyre}) = \frac{\text{Std.dev}(\text{tyre})}{\text{Mean}(\text{tyre})}$$

3.14.3.4.1.2. Weighted averages of two successive tests of the SRTT shall be computed taking into account the number of candidate tyres in between:

In the case of the order of testing R1 – T – R2, the weighted average of the SRTT to be used in the comparison of the performance of the candidate tyre shall be taken to be:

$$\text{wa}(\text{SRTT}) = (\text{R1} + \text{R2})/2$$

Where:

R1 is the mean mfdd for the first test of the SRTT and

R2 is the mean mfdd for the second test of the SRTT.

In the case of the order of testing R1 – T1 – T2 – R2, the weighted average (wa) of the SRTT to be used in the comparison of the performance of the candidate tyre shall be taken to be:

wa (SRTT) = 2/3 R1 + 1/3 R2 for comparison with the candidate tyre T1; and:

wa (SRTT) = 1/3 R1 + 2/3 R2 for comparison with the candidate tyre T2.

3.14.3.4.1.3. The snow grip index (SG) of a candidate tyre shall be computed as:

$$\text{Snow Grip Index (candidate)} = \frac{\text{Mean (candidate)}}{\text{wa (SRTT)}}$$

3.14.3.4.2. Statistical validations

The sets of repeats of measured or computed mfdd for each tyre should be examined for normality, drift, eventual outliers.

The consistency of the means and standard-deviations of successive braking tests of SRTT should be examined.

The means of two successive SRTT braking tests shall not differ by more than 5 per cent.

The coefficient of variation of any braking test shall be less than 6 per cent.

If those conditions are not met, tests shall be performed again after re-grooming the test course.

3.14.3.4.3. In the case where the candidate tyres cannot be fitted to the same vehicle as the SRTT, for example, due to tyre size, inability to achieve required loading and so on, comparison shall be made using intermediate tyres, hereinafter referred to as "control tyres", and two different vehicles. One vehicle shall be capable of being fitted with the SRTT and the control tyre and the other vehicle shall be capable of being fitted with the control tyre and the candidate tyre.

3.14.3.4.3.1 The snow grip index of the control tyre relative to the SRTT (SG1) and of the candidate tyre relative to the control tyre (SG2) shall be established using the procedure in paragraphs 3.14.3.1. to 3.14.3.4.2.

The snow grip index of the candidate tyre relative to the SRTT shall be the product of the two resulting snow grip indices that is $SG1 \cdot SG2$.

3.14.3.4.3.2. The ambient conditions shall be comparable. All tests shall be completed within the same day.

3.14.3.4.3.3. The same set of control tyres shall be used for comparison with the SRTT and with the candidate tyre and shall be fitted in the same wheel positions.

3.14.3.4.3.4. Control tyres that have been used for testing shall subsequently be stored under the same conditions as required for the SRTT.

3.14.3.4.3.5. The SRTT and control tyres shall be discarded if there is irregular wear or damage or when the performance appears to have been deteriorated."

3.14.4. Acceleration method for Class C3 tyres

3.14.4.1. According to the definition of Class C3 tyres reported into paragraph 2.17., the additional classification for the purpose of this test method only applies:

- (a) Class C3 Narrow (C3N), when the Class C3 tyre Nominal Section Width is lower than 285 mm;
- (b) Class C3 Wide (C3W), when the Class C3 tyre Nominal Section Width is greater or equal to 285 mm.

3.14.4.2. Methods for measuring Snow Grip Index

Snow performance is based on a test method by which the average acceleration in an acceleration test, of a candidate tyre is compared to that of a standard reference tyre.

The relative performance shall be indicated by a Snow Grip Index (SG).

When tested in accordance with the acceleration test in paragraph 3.14.4.7., the average acceleration of a candidate snow tyre shall be at least 1.25 compared to one of the two equivalent SRTTs – ASTM F 2870 and ASTM F 2871.

3.14.4.3. Measuring equipment

3.14.4.3.1. A sensor suitable for measuring speed and distance covered on snow/ice surface between two speeds must be used.

To measure vehicle speed, a fifth wheel or non-contact speed-measuring system (including radar, GPS, ...) shall be used.

3.14.4.3.2. The following tolerances shall be respected:

(a) For speed measurements: ± 1 per cent (km/h) or 0.5 km/h whichever is greater.

(b) For distance measurements: $\pm 1 \cdot 10^{-1}$ m

3.14.4.3.3. A display of the measured speed or the difference between the measured speed and the reference speed for the test is recommended inside the vehicle so that the driver can adjust the speed of the vehicle.

3.14.4.3.4. For Acceleration test covered in paragraph 3.14.4.7., a display of the slip ratio of the driven tyres is recommended inside the vehicle and shall be used in the particular case of paragraph 3.14.4.7.2.1.1.

The slip ratio is calculated by

$$\text{Slip Ratio \%} = \left[\frac{\text{WheelSpeed} - \text{Vehicle Speed}}{\text{Vehicle Speed}} \right] \cdot 100$$

(a) Vehicle speed is measured as defined in 3.14.4.3.1. (m/s)

(b) Wheel speed is calculated on a tyre of the driven axle by measuring its angular velocity and its loaded diameter

$$\text{wheel speed} = \pi \cdot \text{loaded diameter} \cdot \text{angular speed}$$

Where, $\pi = 3.1416$ (m/360deg), the loaded diameter (m) and the angular speed (revolutions per second = 360 deg/sec).

3.14.4.3.5. A data acquisition system can be used for storing the measurements.

3.14.4.4. General conditions

3.14.4.4.1. Test course

The test shall be done on a flat test surface of sufficient length and width, with a maximum 2 per cent gradient, covered with packed snow.

3.14.4.4.1.1. The snow surface shall be composed of a hard packed snow base at least 3 cm thick and a surface layer of medium packed and prepared snow about 2 cm thick.

3.14.4.4.1.2. The snow compaction index measured with a CTI penetrometer shall be between 80 and 90. Refer to the appendix of ASTM F1805 for additional details on measuring method.

3.14.4.4.1.3. The air temperature, measured about one meter above the ground, shall be between -2 °C and -15 °C; the snow temperature, measured at a depth of about one centimeter, shall be between -4 °C and -15 °C.

Air temperature shall not vary more than 10 °C during the test.

3.14.4.5. Tyres preparation and break-in

3.14.4.5.1. Mount the tyre on a test rim with a width comprised between the minimum and maximum width as per Annex 9. The rim contour shall be one of those specified for the fitment of the test tyre.

All tyres of the same size have to be tested on the same test rim width and contour.

Ensure proper bead seating by the use of a suitable lubricant. Excessive use of lubricant should be avoided to prevent slipping of the tyre on the wheel rim.

3.14.4.5.2. The tyres should be "broken-in" prior to testing to remove spew, compound nodules or flashes resulting from moulding process.

3.14.4.5.3. Tyres shall be conditioned at the outdoor ambient temperature at least two hours before their mounting for tests.

They should be placed such that they all have the same ambient temperature prior to testing and be shielded from the sun to avoid excessive heating by solar radiation.

The tyre surface in contact with snow shall be cleaned before performing a test.

Tyre pressures shall then be adjusted to the values specified for the test.

3.14.4.6. Testing sequence

If only one candidate tyre is to be evaluated, the order of testing shall be:

R1 – T – R2

where:

R1 is the initial test of the SRTT, R2 is the repeat test of the SRTT and T is the test of the candidate tyre to be evaluated.

A maximum of 3 candidate tyres may be tested before repeating the SRTT test, for example: R1 – T1 – T2 – T3 – R2.

Recommendations are that the zones where acceleration is fully applied shall not overlap without reworking and when a new set of tyres is tested.

The runs are performed after shifting the vehicle trajectory in order not to accelerate on the tracks of the previous tyre; when it is no longer possible not to overlap full acceleration zones, the test course should be re-groomed.

3.14.4.7. Acceleration on Snow Test Procedure for Snow Grip Index of Class C3N and C3W

3.14.4.7.1. Principle

The test method covers a procedure for measuring the Snow Grip performance of commercial vehicle tyres during acceleration, using a commercial vehicle having a Traction Control System (TCS, ASR, etc.).

Starting with a defined initial speed, the full throttle is applied to activate the Traction Control system, the Average acceleration is calculated between two defined speeds.

3.14.4.7.2. Vehicle

- 3.14.4.7.2.1. The test shall be conducted with a standard 2 axle commercial vehicle in good running order with:
- (a) Low rear axle weight and an engine powerful enough to maintain the average percentage of slip during the test as required in paragraphs 3.14.4.7.5.1. and 3.14.4.7.5.2.1. below;
 - (b) A manual gearbox (automatic gearbox with manual shift allowed) having a gear ratio covering the speed range of at least 19 km/h between 4 km/h and 30 km/h;
 - (c) Differential lock on driven axle is recommended to improve repeatability;
 - (d) A standard commercial system controlling/limiting the slip of the driving axle during acceleration (Traction Control, ASR, TCS, etc.).
- 3.14.4.7.2.1.1. In the particular case where a standard commercial vehicle equipped with a traction control system is not available, a vehicle without Traction Control/ASR/TCS is permitted provided the vehicle is fitted with a system to display the percentage slip as stated in paragraph 3.14.4.3.4. and a mandatory differential lock on the driven axle used in accordance with operating procedure described in paragraph 3.14.4.7.5.2.1. below. If a differential lock is available it shall be used; if the differential lock, however, is not available, the average slip ratio should be measured on the left and right driven wheel.
- 3.14.4.7.2.2. The permitted modifications are:
- (a) Those allowing to increase the number of tyre sizes capable to be mounted on the vehicle;
 - (b) Those permitting to install an automatic activation of the acceleration and the measurements.
- Any other modification of the acceleration system is prohibited.
- 3.14.4.7.3. Vehicle fitting
- The rear driven axle may be indifferently fitted with 2 or 4 test tyres if respecting the loading by tyre.
- The front steer non-driven axle is equipped with 2 tyres having a size suitable for the axle load. These 2 front tyres could be maintained along the test.
- 3.14.4.7.4. Load and inflation pressure
- 3.14.4.7.4.1. The static load on each rear driven test tyres must be between 20 per cent and 55 per cent of the tested maximum load rating of the tested tyre written on the sidewall.
- The vehicle front steer total static axle load should be between 60 per cent and 160 per cent of the driven rear total axle load.
- The static tyre load on the same driven axle should not differ by more than 10 per cent.
- 3.14.4.7.4.2. The driven tyres inflation pressure shall be 70 per cent of the one written on the sidewall.
- The steer tyres are inflated at the Reference Test Inflation Pressure
- 3.14.4.7.5. Testing Runs

- 3.14.4.7.5.1. Mount first the set of reference tyres on the vehicle and when on the testing area.

Drive the vehicle at a constant speed between 4 km/h and 11 km/h and the gear ratio capable of covering the speed range of at least 19 km/h for the complete test programme (e.g. R – T1 – T2 – T3 – R).

The Recommended Gear ratio selected is 3rd or 4th and shall give a minimum 10 per cent average slip ratio in the measured range of speed.

- 3.14.4.7.5.2. In case of Traction Control system equipped vehicles (already switched "on" before the run) apply full throttle until the vehicle has reached the final speed:

Final speed = Initial speed + 15 km/h

No rearward restraining force shall be applied to the test vehicle.

- 3.14.4.7.5.2.1. In the particular case of paragraph 3.14.4.7.2.1.1. where a standard commercial vehicle equipped with a Traction Control system is not available, the driver shall manually maintain the average slip ratio between 10 and 40 per cent (Controlled Slip procedure in place of the Full Slip) within the prescribed range of speeds. If a differential lock is not available, the averaged slip ratio difference between the left and right driven wheel shall not be higher than 8 per cent for each run. All the tyres and runs in the test session are performed with Controlled Slip procedure.

- 3.14.4.7.5.3. Measure the distance between the initial speed and the final speed.

- 3.14.4.7.5.4. For every candidate tyre and the standard reference tyre, the acceleration test runs shall be repeated a minimum of 6 times and the coefficients of variation (standard deviation/average • 100) calculated for minimum 6 valid runs on the distance shall be lower than or equal to 6 per cent.

- 3.14.4.7.5.5. In case of Traction Control System equipped vehicle, the Average Slip ratio shall be in the range from 10 per cent to 40 per cent (calculated as per paragraph 3.14.4.3.4.).

- 3.14.4.7.5.6. Apply testing sequence as defined in paragraph 3.14.4.6.

- 3.14.4.8. Processing of measurement results

- 3.14.4.8.1. Calculation of the Average Acceleration AA

Each time the measurement is repeated, the average acceleration AA ($m \cdot s^{-2}$) is calculated by:

$$AA = \frac{S_f^2 - S_i^2}{2D}$$

Where D [m] is the distance covered between the initial speed S_i [$m \cdot s^{-1}$] and the final speed S_f [$m \cdot s^{-1}$].

- 3.14.4.8.2. Validation of results

For the candidate tyres:

The coefficients of variation of the Average Acceleration is calculated for all the candidate tyres. If one coefficient of variation is greater than 6 per cent, discard the data for this candidate tyre and repeat the test.

$$\text{coefficient of variation} = \frac{\text{stdev}}{\text{average}} \cdot 100$$

For the reference tyre:

If the coefficient of variation of the average Acceleration "AA" for each group of minimum 6 runs of the reference tyre is higher than 6 per cent, discard all data and repeat the test for all tyres (the candidate tyres and the reference tyre).

In addition, and in order to take in account possible test evolution, the coefficient of validation is calculated on the basis of the average values of any two consecutive groups of minimum 6 runs of the reference tyre. If the coefficient of validation is greater than 6 per cent, discard the data for all the candidate tyres and repeat the test.

$$\text{coefficient of variation} = \left| \frac{\text{Average2} - \text{Average1}}{\text{Average1}} \right| \cdot 100$$

3.14.4.8.3. Calculation of the "average AA"

If R1 is the average of the "AA" values in the first test of the reference tyre, R2 is the average of the "AA" values in the second test of the reference tyre, the following operations are performed, according to Table 44:

Table 44

"Ra" calculation

<i>If the number of sets of candidate tyres between two successive runs of the reference tyre is:</i>	<i>and the set of candidate tyres to be qualified is:</i>	<i>then "Ra" is calculated by applying the following:</i>
1 R – T1 – R	T1	Ra = 1/2 (R1 + R2)
2 R – T1 – T2 – R	T1 T2	Ra = 2/3 R1 + 1/3 R2 Ra = 1/3 R1 + 2/3 R2
3 R – T1 – T2 – T3 – R	T1 T2 T3	Ra = 3/4 R1 + 1/4 R2 Ra = 1/2 (R1 + R2) Ra = 1/4 R1 + 3/4 R2

"Ta" (a = 1, 2, ...) is the average of the AA values for a test of a candidate tyre.

3.14.4.8.4. "AFC" Calculation (Acceleration Force Coefficient)

Also called AFC Acceleration Force Coefficient

Calculation on of AFC(T) and AFC(R) as defined in Table 45:

Table 45

Acceleration force coefficient "AFC" calculation

	<i>The Acceleration Force Coefficient "AFC" is:</i>
Reference tyre	$AFC(R) = \frac{Ra}{g}$
Candidate tyre	$AFC(T) = \frac{Ta}{g}$

Ra and Ta are in m/s²

"g"= gravity acceleration (rounded to 9.81 m/s²)

3.14.4.8.5. Calculation of the relative Snow Grip Index of the tyre

The Snow grip index represents the relative performance of the candidate tyre compared to the reference tyre:

$$\text{Snow Grip Index} = \frac{AFC(T)}{AFC(R)}$$

3.14.4.8.6. Calculation of the Slip Ratio

The slip ratio can be calculated as the average of Slip ratio as mentioned in paragraph 3.14.4.3.4. or by comparing the average distance referred to in paragraph 3.14.4.7.5.3. of the minimum 6 runs to the distance of a run done without slip (very low acceleration)

$$\text{Slip Ratio}\% = \left[\frac{\text{Averagedistance} - \text{No slip distance}}{\text{No slip distance}} \right] \cdot 100$$

No slip distance means the wheel distance calculated on a run done with a constant speed or a continuous low acceleration.

3.14.4.9. Snow grip performance comparison between a candidate tyre and a reference tyre using a control tyre

3.14.4.9.1. Scope

When the candidate tyre size is significantly different from the reference tyre a direct comparison on the same vehicle may be not possible. This is an approach using an intermediate tyre, hereinafter called the control tyre.

3.14.4.9.2. Principle of the approach

The principle lies upon the use of a control tyre and 2 different vehicles for the assessment of a candidate tyre in comparison with a reference tyre.

One vehicle can fit the reference tyre and the control tyre, the other the control tyre and the candidate tyre. All conditions are in conformity with paragraph 3.14.4.7.

The first assessment is a comparison between the control tyre and the reference tyre. The result (Snow Grip Index 1) is the relative efficiency of the control tyre compared to the reference tyre.

The second assessment is a comparison between the candidate tyre and the control tyre. The result (Snow Grip Index 2) is the relative efficiency of the candidate tyre compared to the control tyre.

The second assessment is done on the same track as the first one. The air temperature must be in the range of ± 5 °C of the temperature of the first assessment. The control tyre set is the same set as the set used for the first assessment.

The Snow Grip Performance Index of the candidate tyre compared to the reference tyre is deduced by multiplying the relative efficiencies calculated above:

$$\text{Snow Grip Index} = \text{SG1} \cdot \text{SG2}$$

3.14.4.9.3. Selection of a set of tyres as a control tyre set

A control tyre set is a group of identical tyres made in the same factory during one week period.

3.14.4.10. Storage and preservation

Before the first assessment (control tyre / reference tyre), normal storage conditions can be used. It is necessary that all the tyres of a control tyre set have been stored in the same conditions.

As soon as the control tyre set has been assessed in comparison with the reference tyre, specific storage conditions shall be applied for Control tyres replacement.

When irregular wear or damage results from tests, or when wear influences the test results, the use of the tyre shall be discontinued.

Annex 1 Speed symbol table

Table A1/ 1

<i>Speed symbol</i>	<i>Corresponding speed km/h</i>
F	80
G	90
J	100
K	110
L	120
M	130
N	140
P	150
Q	160
R	170
S	180
T	190
U	200
H	210
V	240
W	270
Y	300

Annex 2 Load Index (LI) and equivalent maximum load rating table

Table A2/ 1

<i>LI</i>	<i>kg</i>	<i>LI</i>	<i>kg</i>	<i>LI</i>	<i>kg</i>	<i>LI</i>	<i>kg</i>	<i>LI</i>	<i>kg</i>
0	45	27	97.5	54	212	81	462	108	1 000
1	46.2	28	100	55	218	82	475	109	1 030
2	47.5	29	103	56	224	83	487	110	1 060
3	48.7	30	106	57	230	84	500	111	1 090
4	50.0	31	109	58	236	85	515	112	1 120
5	51.5	32	112	59	243	86	530	113	1 150
6	53.0	33	115	60	250	87	545	114	1 180
7	54.5	34	118	61	257	88	560	115	1 215
8	56.0	35	121	62	265	89	580	116	1 250
9	58.0	36	125	63	272	90	600	117	1 285
10	60.0	37	128	64	280	91	615	118	1 320
11	61.5	38	132	65	290	92	630	119	1 360
12	63.0	39	136	66	300	93	650	120	1 400
13	65.0	40	140	67	307	94	670	121	1 450
14	67.0	41	145	68	315	95	690	122	1 500
15	69.0	42	150	69	325	96	710	123	1 550
16	71.0	43	155	70	335	97	730	124	1 600
17	73.0	44	160	71	345	98	750	125	1 650
18	75.0	45	165	72	355	99	775	126	1 700
19	77.5	46	170	73	365	100	800	127	1 750
20	80.0	47	175	74	375	101	825	128	1 800
21	82.5	48	180	75	387	102	850	129	1 850
22	85.0	49	185	76	400	103	875	130	1 900
23	87.5	50	190	77	412	104	900	131	1 950
24	90.0	51	195	78	425	105	925		
25	92.5	52	200	79	437	106	950		
26	95.0	53	206	80	450	107	975		

Annex 3 Nominal rim diameter code table

Table A3/ 1

<i>Nominal rim diameter code ("d" symbol)</i>	<i>Value of the "d" symbol (expressed in mm)</i>
9	229
10	254
11	279
12	305
13	330
14	356
14.5	368
15	381
16	406
16.5	419
17	432
17.5	445
18	457
19	483
19.5	495
20	508
20.5	521
21	533
22	559
22.5	572
23	584
24	610
24.5	622
25	635
26	660
27	686
28	711
29	737
30	762

Annex 4 Tyre size designation examples and description

1. Metric tyres:

225/50R17

Where

225 is the Nominal Section Width (mm)

50 is the Nominal Aspect Ratio

R is the Structure or Construction Code

17 is the Nominal Rim Diameter Code

In the case of Metric-A tyres:

195-620R420A

Where

195 is the Nominal Section Width (mm)

620 is the Nominal Overall Diameter

R is the Structure or Construction Code

420 is the Nominal Rim Diameter

A indicates a Metric A Rim (Asymmetric)

In the case of P-metric tyre sizes:

P225/50R17

Where

P indicates a P-metric size

225 is the Nominal Section Width (mm)

50 is the Nominal Aspect Ratio

R is the Structure or Construction Code

17 is the Nominal Rim Diameter Code

LT/C tyre with a “LT-metric” size designation:

LT225/75R16

or **225/75R16LT**

or **225/75R16 118/116N LT**

Where

225 is the Nominal Section Width (mm)

75 is the Nominal Aspect Ratio

R is the Structure or Construction Code

16 is the Nominal Rim Diameter Code

LT is indicating a Light Truck tyre

118/116 N is the Service Description

LT/C tyre with a “C type” size designation:

225/75R16C

Where

225 is the Nominal Section Width (mm)

75 is the Nominal Aspect Ratio

R is the Structure or Construction Code

16 is the Nominal Rim Diameter Code

C is indicating a Commercial tyre

2. High flotation tyres:

31x10.50R15LT

Where

31 is the Nominal Overall Diameter Code

10.50 is the Nominal Section Width Code, and must end in .50

R is the Structure or Construction Code

15 is the Nominal Rim Diameter Code

LT indicates a Light Truck Tyre

To convert dimensions expressed in code to mm, multiply the code by 25.4 and round to the nearest mm.

3. Sizes listed in Annex 6 (non-exhaustive list of examples):

7.00R16

or 7.00R16C

Where

7.00 is the Nominal Section Width code (inches)

R is the Structure or Construction Code

16 is the Nominal Rim Diameter Code

C is indicating a Commercial tyre

7.00R16 LT

or 7.00R16 116/114N LT

Where

7.00 is the Nominal Section Width code (inches)

R is the Structure or Construction Code

16 is the Nominal Rim Diameter Code

116/114N is the Service Description

LT is indicating a Light Truck tyre

185R14C

Where

185 is the Nominal Section Width (mm)

R is the Structure or Construction Code

14 is the Nominal Rim Diameter Code

C is indicating a Commercial tyre

Annex 5 Variation of load capacity with speed

Variation of load capacity with speed for Passenger car tyres

For speeds not exceeding 210 km/h, the load capacity shall not exceed the value associated with the load index of the tyre.

For speeds above 210 km/h, the following table applies:

Table A5/ 1

Variation of load capacity (per cent)¹

Speed (km/h)	Tyre speed symbol		
	V	W	Y
210	0	0	0
220	-3	0	0
230	-6	0	0
240	-9	0	0
250		-5	0
260		-10	0
270		-15	0
280			-5
290			-10
300			-15

¹ For intermediate speeds, linear interpolation is permitted.

Variation of load capacity with speed for LT/C tyres

The following table defines the variation of load capacity for LT/C tyres:

Table A5/ 2

Variation of load capacity (per cent)

Speed (km/h)	All load indices				Load indices ≥ 122 ¹		Load indices ≤ 121 ²²			
	Tyre speed symbol				Tyre speed symbol		Tyre speed symbol			
	F	G	J	K	L	M	L	M	N	P ²
0	+150	+150	+150	+150	+150	+150	+110	+110	+110	+110
5	+110	+110	+110	+110	+110	+110	+90	+90	+90	+90
10	+80	+80	+80	+80	+80	+80	+75	+75	+75	+75
15	+65	+65	+65	+65	+65	+65	+60	+60	+60	+60
20	+50	+50	+50	+50	+50	+50	+50	+50	+50	+50
25	+35	+35	+35	+35	+35	+35	+42	+42	+42	+42
30	+25	+25	+25	+25	+25	+25	+35	+35	+35	+35
35	+19	+19	+19	+19	+19	+19	+29	+29	+29	+29
40	+15	+15	+15	+15	+15	+15	+25	+25	+25	+25
45	+13	+13	+13	+13	+13	+13	+22	+22	+22	+22
50	+12	+12	+12	+12	+12	+12	+20	+20	+20	+20
55	+11	+11	+11	+11	+11	+11	+17.5	+17.5	+17.5	+17.5
60	+10	+10	+10	+10	+10	+10	+15.0	+15.0	+15.0	+15.0
65	+7.5	+8.5	+8.5	+8.5	+8.5	+8.5	+13.5	+13.5	+13.5	+13.5
70	+5.0	+7.0	+7.0	+7.0	+7.0	+7.0	+12.5	+12.5	+12.5	+12.5
75	+2.5	+5.5	+5.5	+5.5	+5.5	+5.5	+11.0	+11.0	+11.0	+11.0
80	0	+4.0	+4.0	+4.0	+4.0	+4.0	+10.0	+10.0	+10.0	+10.0
85	-3	+2.0	+3.0	+3.0	+3.0	+3.0	+8.5	+8.5	+8.5	+8.5
90	-6	0	+2.0	+2.0	+2.0	+2.0	+7.5	+7.5	+7.5	+7.5
95	-10	-2.5	+1.0	+1.0	+1.0	+1.0	+6.5	+6.5	+6.5	+6.5
100	-15	-5	0	0	0	0	+5.0	+5.0	+5.0	+5.0
105		-8	-2	0	0	0	+3.75	+3.75	+3.75	+3.75
110		-13	-4	0	0	0	+2.5	+2.5	+2.5	+2.5
115			-7	-3	0	0	+1.25	+1.25	+1.25	+1.25
120			-12	-7	0	0	0	0	0	0
125						0	-2.5	0	0	0
130						0	-5.0	0	0	0
135							-7.5	-2.5	0	0
140							-10	-5	0	0
145								-7.5	-2.5	0
150								-10.0	-5.0	0
155									-7.5	-2.5
160									-10.0	-5.0

¹ The load indices refer to a single operation.

² Load variations are not allowed for speeds above 160 km/h. For tyre speed symbols "Q" and above the speed corresponding to the tyre speed symbol (Annex 1) specifies the maximum speed permitted for the tyre.

Annex 6 Tyre-size designations and dimensions

Table A6/ 1

Code designated sizes mounted on 5° tapered rims or flat base rims

<i>Tyre size designation</i>	<i>Measuring rim width code</i>	<i>Minimum rim width code</i>	<i>Maximum rim width code</i>	<i>Nominal rim diameter d (mm)</i>	<i>Outer diameter D (mm)</i>	<i>Section width S (mm)</i>
4.00R10 ^(*)	3	3	3	254	466	108
4.00R12 ^(*)	3	3	3	305	517	108
4.50R10 ^(*)	3	3	3.5	254	490	125
4.50R12 ^(*)	3	3	3.5	305	545	125
5.00R10 ^(*)	3.5	3	4	254	516	134
5.00R12 ^(*)	3.5	3	4	305	568	134
6.00R9	4	3.5	5	229	540	160
6.00R14C	4	3.5	5	356	626	158
6.00R16 ^(*)	4	3.5	5	406	728	170
6.50R10	4.5	3.5	5	254	588	177
6.50R14C	4.5	3.5	5	356	640	170
6.50R16 ^(*)	4.5	3.5	5	406	742	176
6.50R20 ^(*)	4.5	3.5	5	508	860	181
7.00R12	5	4	5.5	305	672	192
7.00R14C	5	4	5.5	356	650	180
7.00R15 ^(*)	5	4	5.5	381	746	197
7.00R16C	5	4	5.5	406	778	198
7.00R16	5	4	5.5	406	784	198
7.00R20	5	4	5.5	508	892	198
7.50R10	5.5	4	6	254	645	207
7.50R14C	5.5	4	6	356	686	195
7.50R15 ^(*)	5.5	4	6	381	772	212
7.50R16 ^(*)	5.5	4	6	406	802	210
7.50R17 ^(*)	5.5	4	6	432	852	210
8.25R15	6	4.5	6.5	381	836	230
8.25R16	6	4.5	6.5	406	860	230
9.00R15	6.5	5	7	381	840	249
9.00R16 ^(*)	6.5	5	7	406	912	246

(*) The tyre size designation may be supplemented with the letter "C".

Table A6/ 2
Tyres for light commercial vehicles

<i>Tyre size designation</i>	<i>Measuring rim width code</i>	<i>Minimum rim width code</i>	<i>Maximum rim width code</i>	<i>Nominal rim diameter d (mm)</i>	<i>Outer diameter D (mm)</i>	<i>Section width S (mm)</i>
145 R 10 C	4.00	3.50	4.50	254	492	147
145 R 12 C	4.00	3.50	4.50	305	542	147
145 R 13 C	4.00	3.50	4.50	330	566	147
145 R 14 C	4.00	3.50	4.50	356	590	147
145 R 15 C	4.00	3.50	4.50	381	616	147
155 R 12 C	4.50	4.00	5.00	305	550	157
155 R 13 C	4.50	4.00	5.00	330	578	157
155 R 14 C	4.50	4.00	5.00	356	604	157
165 R 13 C	4.50	4.00	5.00	330	596	167
165 R 14 C	4.50	4.00	5.00	356	622	167
165 R 15 C	4.50	4.00	5.00	381	646	167
175 R 13 C	5.00	4.50	5.50	330	608	178
175 R 14 C	5.00	4.50	5.50	356	634	178
175 R 16 C	5.00	4.50	5.50	406	684	178
185 R 13 C	5.50	5.00	6.00	330	624	188
185 R 14 C	5.50	5.00	6.00	356	650	188
185 R 15 C	5.50	5.00	6.00	381	674	188
185 R 16 C	5.50	5.00	6.00	406	700	188
195 R 14 C	5.50	5.00	6.00	356	666	198
195 R 15 C	5.50	5.00	6.00	381	690	198
195 R 16 C	5.50	5.00	6.00	406	716	198
205 R 14 C	6.00	5.50	6.50	356	686	208
205 R 15 C	6.00	5.50	6.50	381	710	208
205 R 16 C	6.00	5.50	6.50	406	736	208
215 R 14 C	6.00	5.50	6.50	356	700	218
215 R 15 C	6.00	5.50	6.50	381	724	218
215 R 16 C	6.00	5.50	6.50	406	750	218
245 R 16 C	7.00	6.50	7.50	406	798	248
17 R 15 C	5.00	4.50	5.50	381	678	178
17 R 380 C	5.00	4.50	5.50	381	678	178
17 R 400 C	150 mm	130 mm	150 mm	400	698	186
19 R 400 C	150 mm	130 mm	150 mm	400	728	200
5.60 R 12 C	4.00	3.50	4.50	305	570	150
6.40 R 13 C	4.50	4.00	5.00	330	648	172
6.70 R 13 C	5.00	4.50	5.50	330	660	180
6.70 R 14 C	5.00	4.50	5.50	356	688	180
6.70 R 15 C	5.00	4.50	5.50	381	712	180

Table A6/ 3

Tyres for special applications

<i>Tyre size designation</i>	<i>Measuring rim width code</i>	<i>Minimum rim width code</i>	<i>Maximum rim width code</i>	<i>Nominal rim diameter d (mm)</i>	<i>Outer diameter D (mm)</i>	<i>Section width S (mm)</i>
21x8R9	6.0	5.5	6.5	229	535	200
21x4	3.0	3.0	3.0	330	565	113
22x4 1/2	3.0	3.0	3.5	330	595	132
23x5	3.5	3.5	4.0	330	635	155
23x9R10	7.0	6.0	7.0	254	595	225
25x6	4.0	4.0	4.5	330	680	170
27x10R12	7.5	7.0	8.0	305	690	255
28x9R15	7.0	6.5	7.0	381	707	216
200R15	6.0	5.5	6.5	381	730	205
250R15	7.5	7.0	8.0	381	735	250
300R15	9.0	8.5	9.5	381	840	300

Table A6/ 4

Tyres with LT designation

Outer diameters are listed for the various categories of use: Normal, Snow and Special.

Tyre size designation	Measuring rim width code	Minimum rim width code	Maximum rim width code	Nominal rim diameter d(mm)	Outer diameter D (mm)		Section width S (mm)
					Normal	Snow	
6.00R16LT	4.50	4.50	4.50	406	732	743	173
6.50R16LT	4.50	4.50	6.00	406	755	767	182
6.70R16LT	5.00	4.50	6.00	406	722	733	191
7.00R13LT	5.00	4.50	5.50	330	647	658	187
7.00R14LT	5.00	4.50	6.00	356	670	681	187
7.00R15LT	5.50	5.00	6.50	381	752	763	202
7.00R16LT	5.50	5.00	6.50	406	778	788	202
7.10R15LT	5.00	5.00	5.50	381	738	749	199
7.50R15LT	6.00	5.50	7.00	381	782	794	220
7.50R16LT	6.00	5.50	7.00	406	808	819	220
8.25R16LT	6.50	6.50	7.00	406	859	869	241
9.00R16LT	6.50	6.50	6.50	406	890	903	257
G78R15LT	6.00	5.50	7.00	381	711	722	212
H78R15LT	6.00	5.50	7.00	381	727	739	222
L78R15LT	6.50	6.00	7.00	381	749	760	236
L78R16LT	6.50	6.00	7.00	406	775	786	236
7R14.5LT	6.00	6.00	6.00	368	677	█	185
8R14.5LT	6.00	6.00	6.00	368	707	█	203
9R14.5LT	7.00	7.00	7.00	368	711	█	241
7R17.5LT	5.25	5.25	5.25	445	758	769	189
8R17.5LT	5.25	5.25	5.25	445	788	799	199
9R15LT	8.00	7.00	8.00	381	744	755	254
10R15LT	8.00	7.00	8.50	381	773	783	264
11R15LT	8.00	8.00	8.50	381	777	788	279
8.00R16.5LT	6.00	6.00	6.75	419	720	730	203
8.75R16.5LT	6.75	6.00	6.75	419	748	759	222
9.50R16.5LT	6.75	6.75	8.25	419	776	787	241
10R16.5LT	8.25	8.25	8.25	419	762	773	264
12R16.5LT	9.75	8.25	9.75	419	818	831	307

Table A6/ 5
High flotation LT tyres

Tyre-size designation	Measuring rim width code	Minimum rim width code	Maximum rim width code	Nominal rim diameter <i>d</i> (mm)	Outer diameter <i>D</i> (mm)		Section width <i>S</i> (mm)
					Highway Tread ²	Traction Tread ¹	
24x7.50R13LT	6.00	5.00	6.50	330	597	604	191
27x8.50R14LT	7.00	5.50	7.00	356	674	680	218
28x8.50R15LT	7.00	6.00	7.50	381	699	705	218
29x9.50R15LT	7.50	6.00	8.00	381	724	731	240
30x9.50R15LT	7.50	6.00	8.00	381	750	756	240
31x10.50R15LT	8.50	7.00	9.00	381	775	781	268
31x11.50R15LT	9.00	8.00	10.50	381	775	781	290
31x12.50R15LT	10.00	8.50	11.00	381	775	781	318
31x13.50R15LT	11.00	8.50	11.00	381	775	781	345
31x15.50R15LT	12.50	11.00	13.00	381	775	781	395
32x11.50R15LT	9.00	7.50	10.00	381	801	807	290
33x9.50 R15LT	7.50	6.00	8.00	381	826	832	240
33x10.50R15LT	8.50	7.00	9.00	381	826	832	268
33x10.50R17LT	8.50	7.00	9.00	432	826	832	268
33x10.50R18LT	8.50	7.00	9.00	457	826	832	268
33x11.50R18LT	9.00	8.00	10.50	457	826	832	290
33x11.50R20LT	9.00	8.00	10.50	508	826	832	290
33x12.50R15LT	10.00	8.00	10.50	381	826	832	318
33x12.50R17LT	10.00	8.50	11.00	432	826	832	318
33x12.50R18LT	10.00	8.50	11.00	457	826	832	318
33x12.50R20LT	10.00	8.50	11.00	508	826	832	318
33x12.50R22LT	10.00	8.50	11.00	559	826	832	318
33x13.50R15LT	11.00	9.50	12.00	381	826	832	345
33x15.50R15LT	12.50	11.00	14.00	381	826	832	395
34x10.50R17LT	8.50	7.00	9.00	432	851	858	268
34x12.50R18LT	10.00	8.50	11.00	457	851	858	318
35x11.50R17LT	9.00	7.50	10.00	432	877	883	290
35x11.50R18LT	9.00	7.50	10.00	457	877	883	290
35x11.50R20LT	9.00	8.00	10.50	508	877	883	290
35x12.50R15LT	10.00	8.00	10.50	381	877	883	318
35x12.50R17LT	10.00	8.00	10.50	432	877	883	318
35x12.50R18LT	10.00	8.50	11.00	457	877	883	318
35x12.50R20LT	10.00	8.50	11.00	508	877	883	318
35x12.50R22LT	10.00	8.50	11.00	559	877	883	318
35x13.50R15LT	11.00	9.00	11.50	381	877	883	345
35x13.50R18LT	11.00	9.50	12.00	457	877	883	345
35x13.50R20LT	11.00	9.50	12.00	508	877	883	345
35x14.50R15LT	11.50	10.00	13.00	381	877	883	367
36x13.50R18LT	11.00	9.50	12.00	457	902	908	345

Tyre-size designation	Measuring rim width code	Minimum rim width code	Maximum rim width code	Nominal rim diameter d (mm)	Outer diameter D (mm)		Section width S (mm)
					Highway Tread ²	Traction Tread ¹	
36x14.50R15LT	11.50	9.50	12.50	381	902	908	367
36x14.50R17LT	11.50	10.00	13.00	432	902	908	367
36x14.50R18LT	11.50	10.00	13.00	457	902	908	367
36x15.50R15LT	12.50	11.00	14.00	381	902	908	395
36x15.50R20LT	12.50	11.00	14.00	508	902	908	395
37x11.50R20LT	9.00	7.50	10.00	508	928	934	290
37x12.50R15LT	10.00	8.00	10.50	381	928	934	318
37x12.50R17LT	10.00	8.00	10.50	432	928	934	318
37x12.50R18LT	10.00	8.00	10.50	457	928	934	318
37x12.50R20LT	10.00	8.50	11.00	508	928	934	318
37x12.50R22LT	10.00	8.50	11.00	559	928	934	318
37x13.50R15LT	11.00	9.00	11.50	381	928	934	345
37x13.50R17LT	11.00	9.00	11.50	432	928	934	345
37x13.50R18LT	11.00	9.00	11.50	457	928	934	345
37x13.50R20LT	11.00	9.50	12.00	508	928	934	345
37x13.50R22LT	11.00	9.50	12.00	559	928	934	345
37x13.50R24LT	11.00	9.50	12.00	610	928	934	345
37x13.50R26LT	11.00	9.50	12.00	660	928	934	345
37x14.50R15LT	11.50	9.50	12.50	381	928	934	367
38x13.50R17LT	11.00	9.00	11.50	432	953	959	345
38x13.50R20LT	11.00	9.50	12.00	508	953	959	345
38x13.50R22LT	11.00	9.50	12.00	559	953	959	345
38x13.50R24LT	11.00	9.50	12.00	610	953	959	345
38x14.50R17LT	11.50	9.50	12.50	432	953	959	367
38x14.50R18LT	11.50	10.00	13.00	457	953	959	367
38x14.50R20LT	11.50	10.00	13.00	508	953	959	367
38x15.50R15LT	12.50	10.00	13.00	381	953	959	395
38x15.50R17LT	12.50	11.00	14.00	432	953	959	395
38x15.50R18LT	12.50	11.00	14.00	457	953	959	395
38x15.50R20LT	12.50	11.00	14.00	508	953	959	395
39x13.50R17LT	11.00	9.00	11.50	432	978	985	345
40x13.50R17LT	11.00	9.00	11.50	432	1004	1010	345
40x13.50R20LT	11.00	9.00	11.50	508	1004	1010	345
40x14.50R17LT	11.50	9.50	12.50	432	1004	1010	367
40x14.50R18LT	11.50	9.50	12.50	457	1004	1010	367
40x14.50R20LT	11.50	10.00	13.00	508	1004	1010	367
40x15.50R20LT	12.50	11.00	14.00	508	1004	1010	395
40x15.50R22LT	12.50	11.00	14.00	559	1004	1010	395
40x15.50R24LT	12.50	11.00	14.00	610	1004	1010	395
40x15.50R26LT	12.50	11.00	14.00	660	1004	1010	395
42x14.50R17LT	11.50	9.50	12.50	432	1055	1061	367

Tyre-size designation	Measuring rim width code	Minimum rim width code	Maximum rim width code	Nominal rim diameter d (mm)	Outer diameter D (mm)		Section width S (mm)
					Highway Tread ²	Traction Tread ¹	
42x14.50R20LT	11.50	9.50	12.50	508	1055	1061	367
30x9.50R16.5LT	7.50	6.75	8.25	419	750	761	240
31x10.50R16.5LT	8.25	8.25	8.25	419	775	787	266
33x12.50R16.5LT	9.75	8.25	10.50	419	826	838	315
35x12.50 R16.5LT	10.00	9.75	10.00	419	877	883	318
37x12.50R16.5LT	9.75	8.25	9.75	419	928	939	315
37x14.50R16.5LT	11.25	9.75	12.00	419	928	939	365

¹ Traction Tread tyres are those bearing at least one of the following inscriptions:

- Inscription(s) defined in paragraph 3.3.12.
- Alpine symbol (3-peak-mountain with snowflake) as defined in paragraph 3.3.9 and meeting the requirements of paragraph 3.14.1.
- TRACTION inscription as defined in paragraph 3.3.11.

² Highway Tread tyres are all tyres that are not Traction Tread.

Annex 7 Tyre standards organizations

The Tire and Rim Association. Inc. (TRA)

The European Tyre and Rim Technical Organisation (ETRTO)

The Japan Automobile Tyre Manufacturers' Association (JATMA)

The Tyre and Rim Association of Australia (TRAA)

South Africa Bureau of Standards (SABS)

China Association for Standardization (CAS)

Indian Tyre Technical Advisory Committee (ITTAC)

Associação Latino Americana de Pneus e Aros (Brazil) (ALAPA)

Annex 8 Rolling resistance test equipment tolerances

1. Purpose

The limits specified in this Annex are necessary in order to achieve suitable levels of repeatable test results, which can also be correlated among various test laboratories. These tolerances are not meant to represent a complete set of engineering specifications for test equipment; rather, they should serve as guidelines for achieving reliable test results.
2. Test rims
 - 2.1. Rim Width is specified in paragraph 3.13.3.2 of this regulation.
- 2.2. Run-out

Run-out shall meet the following criteria:

 - (a) Maximum radial run-out: 0.5 mm;
 - (b) Maximum lateral run-out: 0.5 mm.
3. Drum / tyre alignment

General:

Angle deviations are critical to the test results.

 - 3.1. Load application

The direction of tyre loading application shall be kept normal to the test surface and shall pass through the wheel centre within

 - (a) 1 mrad for the force and deceleration methods;
 - (b) 5 mrad for the torque and power methods.
 - 3.2. Tyre alignment
 - 3.2.1. Camber angle

The plane of the wheel shall be perpendicular to the test surface within 2 mrad for all methods.
 - 3.2.2. Slip angle

The plane of the tyre shall be parallel to the direction of the test surface motion within 1 mrad for all methods.
4. Control accuracy

Test conditions shall be maintained at their specified values, independent of perturbations induced by the tyre and rim non-uniformity, such that the overall variability of the rolling resistance measurement is minimized. In order to meet this requirement, the average value of measurements taken during the rolling resistance data collection period shall be within the accuracies stated as follows:

 - (a) Tyre loading:
 - (i) For $LI \leq 121 \pm 20$ N or ± 0.5 per cent, whichever is greater;
 - (ii) For $LI > 121 \pm 45$ N or ± 0.5 per cent, whichever is greater.
 - (b) Cold inflation pressure: ± 3 kPa;

- (c) Surface speed:
 - (i) ± 0.2 km/h for the power, torque and deceleration methods;
 - (ii) ± 0.5 km/h for the force method;
 - (d) Time:
 - (i) ± 0.02 s for the time increments specified in paragraph 3.13.4.5.(b) for the data acquisition in the deceleration method in $\Delta\omega/\Delta t$ form;
 - (ii) ± 0.2 per cent for the time increments specified in paragraph 3.13.4.5.(a) for the data acquisition in the deceleration method in $d\omega/dt$ form;
 - (iii) ± 5 per cent for the other time durations specified in paragraph 3.13.
5. Instrumentation accuracy

The instrumentation used for readout and recording of test data shall be accurate within the tolerances stated below:

Table A8/ 1

Instrumentation tolerances

Parameter	Load Index ≤ 121	Load Index > 121
Tyre load	± 10 N or ± 0.5 % ^(a)	± 30 N or ± 0.5 % ^(a)
Inflation pressure	± 1 kPa	± 1.5 kPa
Spindle force	± 0.5 N or ± 0.5 % ^(a)	± 1.0 N or ± 0.5 % ^(a)
Torque input	± 0.5 Nm or ± 0.5 % ^(a)	± 1.0 Nm or ± 0.5 % ^(a)
Distance	± 1 mm	± 1 mm
Electrical power	± 10 W	± 20 W
Temperature	± 0.2 °C	
Surface speed	± 0.1 km/h	
Time	± 0.01 s or ± 0.1 % or ± 10 s ^(b)	
Angular velocity	± 0.1 %	

^(a) Whichever is greater.

^(b) ± 0.01 s for the time increments specified in paragraph 3.13.4.5.(b) for the data acquisition in the deceleration method in $\Delta\omega/\Delta t$ form
 ± 0.1 per cent for the time increments specified in paragraph 3.13.4.5.(a) for the data acquisition in the deceleration method in $d\omega/dt$ form
 ± 10 s for the other time durations specified in paragraph 3.13.

6. Compensation for load/spindle force interaction and load misalignment for the force method only

Compensation of both load/spindle force interaction (cross talk) and load misalignment may be achieved either by recording the spindle force for both forward and reverse tyre rotation or by dynamic machine calibration. If spindle force is recorded for forward and reverse directions (at each test condition), compensation is achieved by subtracting the reverse value from the forward value and dividing the result by two. If dynamic machine calibration is

intended, the compensation terms may be easily incorporated in the data reduction.

In cases where reverse tyre rotation immediately follows the completion of the forward tyre rotation, a warm-up time for reverse tyre rotation shall be at least 10 minutes for Class C1 tyres and 30 minutes for all other tyre types.

7. Test surface roughness

The roughness, measured laterally, of the smooth steel drum surface shall have a maximum centreline average height value of 6.3 μm .

Note: In cases where a textured drum surface is used instead of a smooth steel surface, this fact is noted in the test report. The surface texture shall then be 180 μm deep (80 grit) and the laboratory is responsible for maintaining the surface roughness characteristics. No specific correction factor is recommended for cases where a textured drum surface is used.

Annex 9 Theoretical, measuring, minimum and maximum rim widths and codes

1. Class C1 tyres

1.1. Metric sizes (excluding all sizes listed in Annex 6).

Theoretical rim width (R_{th})

$$R_{th} = K_1 \cdot S_N$$

where

S_N is the nominal section width.

For tyres mounted on 5° rims (code-designated) with nominal rim diameter expressed by a two-figure code:

- $K_1 = 0.7$ where the tyres have a nominal aspect ratio of 50 to 95;
- $K_1 = 0.85$ where this ratio is 20 to 45.

Measuring rim width code (R_{mc})

$$R_{mc} = \frac{K_2 \cdot S_N}{25.4}$$

For tyres mounted on 5° drop-centre rims with a nominal diameter expressed by a two-figure code:

- $K_2 = 0.7$ for nominal aspect ratios 95 to 75;
- $K_2 = 0.75$ for nominal aspect ratios 70 to 60;
- $K_2 = 0.8$ for nominal aspect ratios 55 and 50;
- $K_2 = 0.85$ for nominal aspect ratio 45;
- $K_2 = 0.9$ for nominal aspect ratios 40 to 30;
- $K_2 = 0.92$ for nominal aspect ratios 20 and 25.

Minimum and maximum rim width codes

The minimum and maximum rim width codes for the nominal aspect ratio of 35 and above are calculated as the product of the nominal section width, S_N , and the coefficients shown in Table Coefficients for calculation of rim widths below, divided by 25.4. Round the values obtained to the nearest 0.5 rim width code. For tyre sizes with a nominal aspect ratio of 30 and below, the minimum and maximum rim width codes are the measuring rim width code ± 0.5 .

Table A9/ 1

Coefficients for calculation of rim widths

Nominal aspect ratio H/S	Coefficients for calculation of the minimum and maximum rim width	
	Minimum	Maximum
$70 \leq H/S \leq 95$	0.65	0.85
$50 \leq H/S \leq 65$	0.70	0.90
$H/S = 45$	0.80	0.95
$35 \leq H/S \leq 40$	0.85	1.00
$H/S \leq 30$	Measuring rim width code - 0.5	Measuring rim width code + 0.5

1.2. Sizes listed in Annex 6

For the tyres whose designation is given in the first column of the tables in Annex 6 to this Regulation, the measuring rim code width shall be deemed to be that given opposite the tyre designation in those tables. Minimum and maximum rim width codes are given in Annex 6.

2. Class C2 and Class C3 tyres

2.1. Metric sizes (excluding all sizes listed in Annex 6)

For the choice of coefficients, see Table Coefficients K_1 , K_4 .

Theoretical rim width (R_{th})

The theoretical rim width, R_{th} , is equal to the product of the nominal section width, S_N , and the coefficient K_1 , (see Table Coefficients K_1 , K_4):

$$R_{th} = K_1 \cdot S_N$$

Measuring rim width code (R_{mc})

The measuring rim width, R_{mc} , is equal to the product of the nominal section width, S_N , and the coefficient, K_4 (see Table Coefficients K_1 , K_4):

$$R_{mc} = K_4 \cdot S_N \text{ rounded to the nearest standardized rim width (see column 2 Table Rim Width Code).}$$

The measuring rim width code is given in column 1 of the Table Rim Width Code, in the row corresponding to the measuring rim width R_{mc} .

Table A9/ 2

Rim width code conversion

<i>Rim width code</i>	<i>Rim width (mm)</i>
3.00	76.0
3.50	89.0
4.00	101.5
4.50	114.5
5.00	127.0
5.50	139.5
6.00	152.5
6.50	165.0
7.00	178.0
7.50	190.5
8.00	203.0
8.50	216.0
9.00	228.5
9.50	241.5
10.00	254.0
10.50	266.5
11.00	279.5
12.00	305.0
13.00	330.0
14.00	355.5
15.00	381.0

Table A9/ 3

Coefficients K_1 , K_2

<i>Nominal aspect ratio H/S</i>	K_1	K_2
100 to 75	0.70	0.70
70, 65	0.70	0.75
60	0.70	0.75
55	0.70	0.80
50	0.70	0.80
45	0.85	0.85
40	0.85	0.90

Minimum and maximum rim width codes

The minimum and maximum rim width codes are determined, for each nominal section width, by multiplying the nominal section width, S_N , by the coefficients, C_R , presented in Table Coefficients for calculation of rim widths

minimum rim width: $C_{R, \min} \cdot S_N$

maximum rim width: $C_{R, \max} \cdot S_N$

The minimum and maximum rim width codes are obtained by rounding these values to the nearest standardized rim width in Table Rim Width Code

Table A9/ 4

Coefficients for calculation of rim widths

Nominal aspect ratio <i>H/S</i>	Coefficients for calculation of minimum and maximum rim width	
	Minimum	Maximum
100 to 75	0.65	0.80
70	0.675	0.80
65	0.70	0.80
60	0.725	0.825
55	0.75	0.825
50	0.75	0.825
45	0.80	0.875
40	0.85	0.925

2.2. High flotation sizes (excluding all sizes listed in Annex 6). 5° tapered rims.

Theoretical rim width, R_{th}

The theoretical rim width, R_{th} , is equal to the product of the nominal section width code (S_1) and the coefficient 0.80.

$$R_{th} = 0.80 \cdot S_1$$

The theoretical rim width A_1 , is equal to the product of the theoretical rim width (R_{th}) by 25.4 and is expressed in mm:

$$A_1 = R_{th} \cdot 25.4$$

Measuring rim width code

The measuring rim width is equal to the theoretical rim width rounded to nearest 0.50 code, as shown in the following table:

Table A9/ 5

Measuring rim width code

<i>Nominal Section Width</i>	<i>Measuring Rim Width Code</i>
7.50	6.00
8.50	7.00
9.50	7.50
10.50	8.50
11.50	9.00
12.50	10.00
13.50	11.00
14.50	11.50
15.50	12.50
16.50	13.00
17.50	14.00
18.50	15.00
19.50	15.50

Minimum and maximum rim width codes

The minimum and maximum rim width codes are determined by multiplying the nominal section width code, S_1 , by the factors in the table below, and rounded to the nearest standardised rim width code.

Table A9/ 6

Minimum and maximum rim width coefficients

<i>Aspect ratio</i> AR	<i>Coefficients for calculation of the minimum and maximum rim width</i>	
	<i>Minimum</i>	<i>Maximum</i>
$70 \leq AR \leq 80$	0.65	0.85
$AR < 70$	0.70	0.90

Aspect Ratio is calculated for High flotation sizes as follows:

$$\text{Aspect Ratio} = ((\text{Outer Diameter } D \text{ (mm)} / 25.4 - \text{Nominal Rim Diameter Code}) / 2) / S_{.80}$$

Whereas $S_{.80}$ is defined as follows:

Table A9/ 7
Coefficient S_{80}

Nominal Section Width	S_{80}
7.50	7.50
8.50	8.47
9.50	9.51
10.50	10.49
11.50	11.52
12.50	12.50
13.50	13.47
14.50	14.51
15.50	15.48
16.50	16.52
17.50	17.50
18.50	18.47
19.50	19.63

2.3. Sizes listed in Annex 6

For the tyres whose designation is given in the first column of the tables in Annex 6 to this Regulation, the measuring rim code width shall be deemed to be that given opposite the tyre designation in those tables. Minimum and maximum rim width codes are given in Annex 6.

Annex 10 Deceleration method: Measurements and data processing for deceleration value **applying the differential form $d\omega/dt$.**

1. Record dependency "distance-time" of rotating body decelerated from peripheral with a speed range such as 82 to 78 km/h or 62 to 58 km/h dependent on tyre class (Paragraph 3.13.4.2., table 40) in a discrete form (figure 1) for a rotating body:

$$z=f(t_z)$$

where:

z is a number of body revolutions during deceleration;

t_z is end time of revolution number z in seconds recorded with 6 digits after zero.

Figure 1

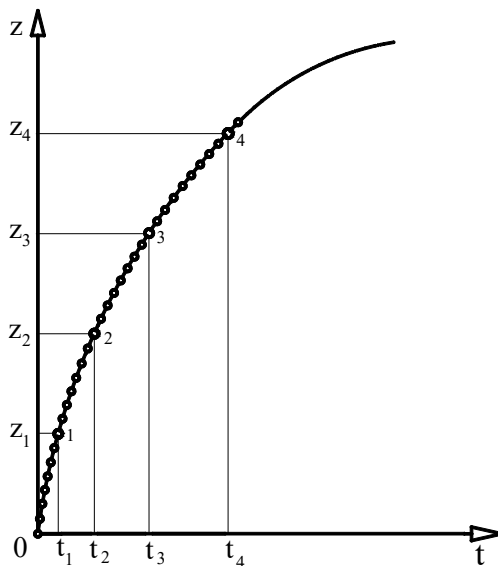

- Note 1:* The lower speed of the recording range may be reduced down to 60 km/h when test speed is 80 km/h and 40 km/h when the test speed is 60 km/h.
2. Approximate recorded dependency by continuous, monotonic, differentiable function:
 - 2.1. Choose the value nearest to the maximum of z dividable by 4 and divide it into 4 equal parts with bounds: $0, z_1(t_1), z_2(t_2), z_3(t_3), z_4(t_4)$.
 - 2.2. Work out the system for 4 equations each of the form:

$$z_m = A \ln \frac{\cos B(T_z - t_m)}{\cos B T_z}$$

where unknowns:

A is a dimensionless constant,
 B is a constant in revolutions per second,
 T_{Σ} is a constant in seconds,
 m is the number of bounds shown in figure 1.

Insert in these 4 equations the coordinates of 4-th bound above.

- 2.3. Take constants A, B and T_{Σ} as the solution of the equation system of paragraph 2.2. above using iteration process and approximate measured data by formulae:

$$z(t) = A \ln \frac{\cos B(T_{\Sigma} - t)}{\cos B T_{\Sigma}}$$

where:

$z(t)$ is the current continuous angular distance in number of revolutions (not only integer values);

t is time in seconds.

Note 2: Other approximating functions $z = f(t_z)$ may be used if their adequacy is proven.

3. Calculate the deceleration j in revolutions per second squared (s^{-2}) by the formula:

$$j = AB^2 + \frac{\omega^2}{A}$$

where:

ω is the angular speed in revolutions per second (s^{-1}).
 For the case $U_n = 80$ km/h; $\omega = 22.222/R_r$ (or R).
 For the case $U_n = 60$ km/h; $\omega = 16.666/R_r$ (or R).

4. Estimate the quality of approximation of measured data and its accuracy by parameters:

- 4.1. Standard deviation in percentages:

$$\sigma = \sqrt{\frac{1}{n-1} \sum_1^n \left[1 - \frac{z(t)}{z} \right]^2} \cdot 100\%$$

- 4.2. Coefficient of determination

$$R^2 = 1 - \frac{\sum_1^n [z - z(t)]^2}{\sum_1^n [z - \bar{z}]^2}$$

where:

$$\bar{z} = \frac{1}{n} \sum_{z=1}^n z = \frac{1}{n} (1+2+\dots+n) = \frac{1+n}{2}$$

Note 3: The above calculations for this variant of the deceleration method for tyre rolling resistance measurement can be executed by the computer programme "Deceleration Calculator" downloadable from the WP.29 website¹ as well as any software which allows the calculation of nonlinear regression.

¹ http://www.unece.org/trans/main/wp29/wp29wgs/wp29gen/deceleration_calculator.html.

Annex 11 Test Equipment Tolerances Specification Guidelines

Table A11/ 1
High-speed durability test bench

Drum diameter	1.7 m \pm 1 per cent or 2.0 m \pm 1 per cent
Drum surface	A smooth wheel
Drum width	surface at least as wide as tyre tread
Test loading device	The loading capability of the test loading equipment shall meet the requirements of the test method and the accuracy shall be within $\pm 1.5\%$ of the full scale.
Test speed	The speed capability of the equipment shall be adequate for the requirements of the test method. The test drum speed shall be within $(+2/-0)$ km/h from the specified value.
Drum radial runout	The radial run-out of the testing machine drum shall be equal or less than 0.25 mm.
Position of the ambient temperature measuring sensor	During the test the ambient temperature is maintained at (35 ± 3) °C. The measurement equipment for ambient temperature shall be placed in a location between 150 mm and 1,000 mm away from the test tyres.

Table A11/ 2
Strength test bench

Steel cylindrical plunger with a hemispherical diameter	a (19 ± 0.5) mm $((0.75 \pm 0.02)$ inch) diameter cylindrical steel plunger
Plunger penetration speed	at the rate of (50 ± 2.5) mm/min $((2 \pm 0.1)$ inches/min)
Force and Penetration measuring device	For the plunger equipment, the loading device shall permit a gradual application of the force. Indicators of displacement and of force shall be provided with accuracy within $\pm 1\%$ of full scale.
Plunger penetration speed monitoring device	For the plunger equipment, the speed of the displacement shall be controlled with an accuracy within $\pm 3\%$ of the full scale.

Table A11/ 3
Inflation device

Inflation device max. range ≥ 100 kPa	For the inflation device, the maximum range shall be equal or higher than 100 kPa and precision shall be ± 10 kPa.
--	--