

Proposal for Amendment 1 of Phase 2 of UN Global Technical Regulation No. 7 (Head restraints)

Submitted by the Informal Working Group on the Phase 2 of UN Global Technical Regulation No. 7

The text reproduced below was prepared by the experts of the Informal Working Group (IWG) on UN Global Technical Regulation No. 7, Phase 2 (GTR7-PH2) and proposes provisions on head restraints. The modifications to the existing text of the UN Global Technical Regulation No. 7 (ECE/TRANS/180/Add.7) are marked in bold for new or strikethrough for deleted characters.

I. Proposal

Table of contents, amend to read:

"Contents

	<i>Page</i>
I. Statement of technical rationale and justification	
A. Phase 1	
1. The safety concerns	
2. Understanding whiplash	
3. Current knowledge.....	
4. Procedural background	
5. Global technical regulation requirements	
6. Lead time	
7. Regulatory impact and economic effectiveness	
8. Review of existing international regulations	
B. Phase 2	
1. Background and context	
2. Procedural background	
3. Requirements of Global technical regulations	
II. Text of the Regulation.....	
1. Purpose.....	
2. Application/Scope	
3. Definitions.....	
4. General requirements	
5. Performance requirements.....	
6. Test conditions	

Annexes

Annex 1	Minimum Height measurement test procedure	
Annex 2	Minimum width measurement test procedure	
Annex 3	GAP measurement test procedure	
Annex 4	Backset measurement test procedure using the HRMD method	
Annex 54	Backset measurement test procedure using the R-point method	

Annex 65	Displacement, backset retention, and strength test procedure
Annex 76	Energy absorption test procedure
Annex 87	Height retention test procedure
Annex 98	Dynamic performance test procedure.....
Annex 109	Non-use position test procedure
Annex 1110	Three-dimensional reference system.....
Annex 1211	Procedure for validation of the H-point and R-point relationship for seating positions in motor vehicles.....
Annex 1312	Description of the three-dimensional H-point machine

Part A, statement of technical rationale and justification, renumber as I and amend to read:

"I. Statement of technical rationale and justification

A. Phase 1

1. The safety concern...
 1. Whiplash injuries...

121. Additionally...also considered.

B. Phase 2

1. Background and context

122. UN GTR No. 7 on heads restraints was established in the Global Registry on 13 March 2008 (ECE/TRANS/180/Add.7). The aim was to mitigate the incidence of soft tissue injuries to the head, neck and spine, (commonly referred to as "whiplash" injuries) that result from vehicle impacts – predominantly rear impacts.

123. UN GTR No. 7 prescribes the use of an anthropometric test device (ATD) to assess the risk of injury, and at the time of adoption, included detailed procedures for the use of the Hybrid III tool. The Biofidelic Rear Impact Dummy II (BioRID II) tool was also recognised as a candidate tool in whiplash mitigation tests for which the UN GTR maintained a section for its subsequent adoption and associated assessment criteria.

124. This amendment to UN GTR No. 7 concerns primarily the adoption of BioRID II. However, following a recommendation from the Executive Committee of the 1998 Agreement (AC.3) of the World Forum for Harmonization of Vehicle Regulation (WP.29), this amendment also amends the procedure for establishing the effective height of a head restraint and includes other editorial and technical changes that increase the effectiveness of the regulation.

125. The changes introduced by this amendment intend not to change the severity of the original requirements. Contracting parties and regional economic integration organizations would, however, be able to adopt a particular or a preferred tool into their national or regional legislation when introducing the BioRID ATD.

2. The Working Party on Passive Safety

126. The World Forum, at its 143rd session in November 2007, agreed to establish an IWG on developing UN GTR No. 7 (ECE/TRANS/WP.29/1064, para. 81) and agreed to consider (Informal document No. WP.29-143-23-Rev.1):

- (a) A head restraint height of 850 mm;
- (b) An appropriate dynamic test, including the test procedure, injury criteria and the associated corridors for the biofidelic rear impact dummy – BioRID II.

127. At its 149th session in November 2009, the representative from Japan, along with the representatives of the United Kingdom and the United States of America submitted

a proposal to AC.3 for developing amendments to the UN GTR. AC.3 adopted the proposal on the basis that the focus, in the first step, would be on developing a low-speed dynamic test using the BioRID II dummy and would begin with the procedures for defining the effective head restraint height. AC.3 acknowledged that detailed discussions on dummies would be conducted by a Technical Evaluation Group (TEG) who would report to the informal group. Detailed drawings on the specifications of the test tools were to be developed and provided to the secretariat as reference material.

128. The dynamic evaluation of seats in addressing minor neck injuries (Maximum Abbreviated Injury Scale 1 – MAIS 1) that occur in low-speed rear impact crashes were conducted by insurance groups (i.e. International Insurance Whiplash Prevention Group (IIWPG), Insurance Institute for Highway Safety (IIHS) and Thatcham). The European New Car Assessment Programme (Euro NCAP) and the Korean New Car Assessment Program (KNCAP) introduced dynamic evaluations of seats in 2008; the Japanese New Car Assessment Programme (JNCAP) in 2009, and the China New Car Assessment Programme in 2012. However, the testing and evaluation methods varied from one programme to another. Additionally, the European Enhanced Vehicle-safety Committee (EEVC) Working Group 12 had investigated the appropriate dynamic test for addressing minor injuries in low-speed crashes. This included the test procedure, injury criteria and the associated corridors for the BioRID II dummy.

129. An in-depth review of a first set of data from the expert of the United States of America showed that while a number of AIS 2 and AIS 3 injuries occur in rear impact crashes at speeds greater than 18 km/h, most of the neck injuries (which are the focus of this UN GTR and which can be evaluated with a rear impact dummy) are AIS 1. AIS 1 injuries occur in approximately equal numbers below or above 18 km/h. Research from the expert of Japan showed similar results, with a significant number of long-term minor neck injuries occurring at 16–25 km/h

(www.unece.org/trans/doc/2010/wp29grsp/GTR7-02-16e.pdf).

130. An evaluation of research by EEVC, "Recommendations for a Low-speed Rear Impact Sled Test Pulse", concluded that most long-term minor neck injuries (greater than one month) are sustained at speeds between 16 and 25 km/h. The expert from the United States of America evaluated several dummies in addressing long-term minor neck injuries and compared them to cadaver testing at 24 km/h.

131. Although previous research differentiated between "low speed" and "medium/high" all the research was conducted at speeds that could be considered as "low speed" for short-term and long-term minor neck injuries. As a complement to the test speed, the IWG developed a comprehensive approach to determining the most appropriate test pulse(s) to mitigate minor neck injuries. This resulted in a level of injury benefit comparable to the requirements of UN GTR No. 7. The IWG also identified options that provided additional benefits focusing on long-term injuries. The IWG suggested developing additional proposals during the time frame of the work schedule but agreed that this work should not delay the principal task.

132. At the 153rd session of the World Forum, the representatives of Japan, the United Kingdom and the United States of America jointly submitted a proposal to amend the Terms of Reference (ToR) so that the dynamic evaluation method under study could focus on reducing injuries from low-speed rear impact crashes. The aim was to finalize the draft amendments to the UN GTR for recommendation at the 2012 December session of GRSP and for establishment at the June 2013 session of AC.3. The amendment proposal for ToR was approved.

133. At the 154th session of the World Forum, a delay was reported in the injury criteria work of the experts of Japan and the United States of America that would

hinder the satisfactory conclusion of the work. In addition, the representative of the United States of America and the United Kingdom questioned whether the dummy drawing package and other specifications would not be better incorporated into a separate UN GTR. The development of a Mutual Resolution No. 1 (M.R.1) suitable for use by both the 1958 and 1998 Agreements was suggested and a proposal submitted to WP.29 for discussion.

134. At the 157th session of the World Forum, the representative of the United Kingdom, on behalf of the Chair of the IWG, reported difficulties in finalising the work on replacing the Hybrid III ATD with the BioRID II ATD within the scheduled timeframe and, that the IWG would require a twelve-month extension of its mandate to deliver the injury criteria. AC.3 agreed to extend the mandate of the IWG until December 2013.

135. At the 158th session of the World Forum, the United States of America and the United Kingdom submitted a proposal (ECE/TRANS/WP.29/2012/124 and WP.29-158-19) for a protocol on drawings, calibration and maintenance procedures associated with test tools referenced by UN Regulations and UN GTR in the framework of the 1958 and 1998 Agreements. Finally, WP.29 and AC.3 adopted the M.R.1 (ECE/TRANS/WP.29/2012/124 as amended by WP.29-158-19).

136. At the 160th session of WP.29, the representative of the United Kingdom, on behalf of the Chair of the IWG on UN GTR No. 7, Phase 2, reported on the progress of IWG and indicated that a two-step approach where amendments to the measurement of head restraint height could proceed in advance of new criteria to incorporate BioRID into the GTR.

AC.3 preferred to proceed in a one-step approach, to consider a complete proposal, including a draft Addendum to M.R.1 and agreed to extend the mandate of the IWG until the end of 2015.

137. At the 166th session of WP.29, the representative of Japan reported on the working progress of the IWG on UN GTR No.7, Phase 2, announcing that the IWG would submit the injury criteria proposal and the pass/fail criteria, at the December 2015 session of GRSP and the final proposal at the May 2016 session of GRSP. AC.3 agreed to extend the mandate of the IWG until December 2016.

138. At the 167th session of WP.29, the representative of Japan reported on the work status of IWG. The group was waiting for output from Post Mortem Human Subjects (PMHS) studies conducted by the National Highway Traffic Safety Administration (NHTSA). This work would help to establish pass/fail criteria. However, while the study performed by NHTSA had provided good data on the reproducibility and repeatability of the BioRID, it was not possible to determine the correlation between the dummy and PMHS. Therefore, more work would be needed to establish statistical significance. He also informed AC.3 that IWG had transmitted an updated draft amendment to the UN GTR to GRSP for discussion at its December 2015 session and that the details of the proposal would be refined before that GRSP session. He added that he expected a final proposal at the May 2016 session of GRSP on UN GTR No. 7 and M.R.1 and that these would be brought to the November 2016 session of WP.29.

139. At the 168th session of WP.29, the representative of the United Kingdom (Chair of AC.3) reported on the work status of IWG. He informed AC.3 that IWG would expect a more advanced proposal at the May 2016 session of GRSP of UN GTR No. 7 and of Addendum 1 to M.R.1 to incorporate BioRID specifications. AC.3 endorsed his request of an extension of the mandate of the IWG until March 2017.

140. At the 170th session of WP.29, the representative of Japan reported on the progress of IWG. Since the IWG meeting in September 2015, studies on PMHS by NHTSA had not been sufficient to provide data to enable the establishment of suitable injury criteria. The IWG was waiting for further study results on PMHS to be conducted by NHTSA, which were expected by spring 2017. He clarified that these results might help the full incorporation of BioRID into the UN GTR and avoid the adoption of empirical values. He advised that the IWG would provide an update on the progress of work at the March 2017 session of AC.3 to seek consent for a revised timetable for the delivery of the proposed amendment to UN GTR No. 7.

141. At the 171st session of WP.29, the Chair of the IWG on UN GTR No.7, Phase 2 reminded WP.29 that the work to establish injury criteria, based on biomechanical data, had been inconclusive and that the work of the group had now been suspended for approximately eighteen months. It appeared that new data would not be available before the end of 2017 and that a different approach might be necessary. AC.3 extended the mandate of the IWG until June 2018.

142. At the 172nd session of WP.29, the representative of the United Kingdom on behalf of the Chair of IWG, reported that IWG had been unable to establish injury criteria directly from PMHS testing but that they had developed some understanding based on empirical data. He added that the expert from the United States of America had agreed to explore their ability to provide further PMHS data, but it seemed likely that they would be able to complete any related work before the end of 2017. Accordingly, AC.3 agreed to extend the time mandate for IWG to allow finalization of its work by using an empirical approach if the data could not be obtained.

143. At the 175th session of WP.29, the Chair of the IWG on Phase 2 of UN GTR No. 7 on head restraints, informed WP.29 that IWG had not been able to establish a correlation between PMHS and BioRID responses. Developing injury criteria directly from PMHS testing required still further research. However, he explained that the IWG intended to re-start its activity to submit an official proposal of amendments, to the UN GTR based on empirical data, at the December 2018 session of GRSP. The a proposed amendments would also be introduced as a revision to UN Regulation R17. The amendments would be presented as:

- (a) an informal document to introduce the latest development of the IWG on injury criteria,
- (b) the final status report of the IWG, and (c) a proposal of Addendum 1 to the M.R.1 to incorporate drawings and specifications of the BioRID.

He expected finalization of this work within one year of activity and therefore requested an extension of the mandate. AC.3 agreed to the extension of the mandate until June 2019.

144. At the 177th session of WP.29, the representative of Japan, as technical sponsor, reported on the progress of work. He recalled that at the 175th session of WP.29 the Chair of the IWG had informed AC.3 of his intention to restart activity. He recalled that a working document on GTR No.7 phase 2 activity had been submitted to the 64th session of GRSP. He explained that GRSP had discussed the remaining items and that the IWG will consider the remaining points in square brackets in preparation for the 65th session of GRSP session in May 2019.¹⁴⁵ Studies with post mortem human subjects (PMHS) by NHTSA have advanced the understanding of the mechanism of Whiplash Associated Disorder. Further PMHS studies will be conducted to improve the data set but at this time correlation between PMHS and BioRID responses has not been established.

146. At the 175th session of WP.29 the Chair of the IWG on Phase 2 of UN GTR No. 7 advised that the group would proceed to establish assessment criteria based upon empirical values. Values were compared with an analysis of data from approximately 150 seats assessed by the European New Car Assessment Programme. This analysis confirmed that seats exhibiting poor whiplash protection performance in the market would be identified using the proposed values.

147. The assessment criteria include both upper and lower neck values. For the upper neck both shear force and extension/flexion criteria are provided. For the lower neck only extension/flexion criteria are provided. Nevertheless, the IWG recognised that consumer testing programmes employing BioRID had identified high lower neck shear force values. While the IWG was not able to recommend assessment values for lower neck shear force it recommends the establishment of such values. Contracting Parties or regional economic integration organizations applying the provisions of this Global Technical Regulation with respect to the use of BioRID are recommended to consider collating data concerning lower neck shear forces that may guide further discussion..

3. Requirements of Global technical regulations

(a) Height of the Head Restraint

(i) Determination of an Effective Height

148. The method of height measurement continued to cause concern regarding the provision of protection for taller occupants. Proposals were put forward in Phase 1 to improve the measurement method, and were fully developed during Phase 2 (See paragraphs 5.1.1.)

149. The UN GTR initially included, a requirement that the height of the head restraint face be a minimum of 100 mm to ensure sufficient surface for contact with the occupant's head. The requirement is assessed in the same manner as the overall height of the head restraint. Questions remained on whether the measurement method addressed the effective height of the head restraint or not. An extremely contoured head restraint example is shown in Figure 1.

Figure 1

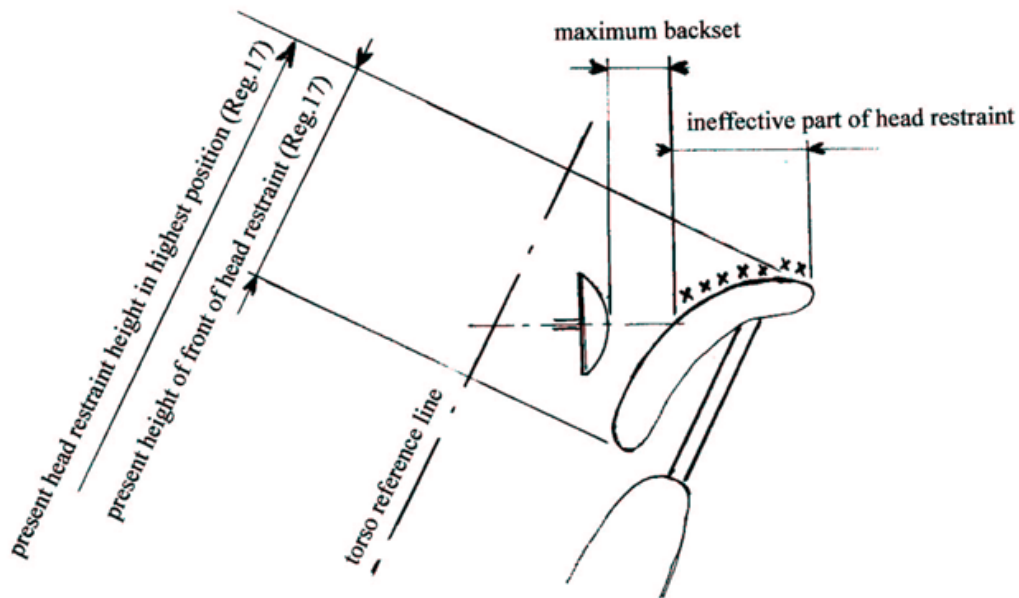

150. The original draft UN GTR No. 7 contained a proposal addressing these concerns, but a final decision was not reached at the time. In response to statements that the back-of-head is dependent on the occupant's height, the expert from the Dutch Organization for Applied Scientific Research (TNO) presented a study (GTR7-04-03). The automotive posture study from UMTRI-83-53-1 (used to create the Head Restraint Measurement Device (HMRD) concept) was combined with the anthropometric database of the Civilian American and European Surface Anthropometry Resource (CAESAR). It was found that in this posture (UMTRI design torso angle) the back-of-head of the CAESAR 2004 NL large male was 39 mm more rearward than an HRMD occupant. In comparison, the UMTRI-86-39 study showed a 31 mm difference in the back-of-head position between the mid-size male and a large male from the 1980s. It was concluded that the effective height (in figure 2 indicated for HRMD-occupant) for this CAESAR 2004 NL large male would be reached at a bigger backset comprising the HRMD backset plus Distance x (here 39 mm). To calculate this "Distance x" for any design torso angle, the principle of the Torso and Neck Link (shown in Annex 5 of UN GTR No.7, Phase 1) is supplemented with an up-scaled Torso and Neck Link representing the CAESAR 2004 NL large male. The resulting calculations are presented as a table expressing the difference in back-of-head position (in direction X) between the mid-sized male (HRMD) and the large male (CEASAR NL 2004 male) at various torso angles and this is defined as Distance x. The test procedure for an effective head restraint height was reduced to the use of goniometric measurements (excluding non-biofidelic interactions) and five simple steps (GTR7-08-03).

151. The point IP would be used for the height measurement of the head restraint and also for checking a minimum height requirement for the front surface of the head restraint. This is recommended, since in Phase 1 some contracting parties expressed the wish to continue regulating a 100 mm minimum height requirement under their current regulation scheme.

(ii) Determination of Height requirement

152. The expert from the Netherlands proposed to measure the height by combining it with the backset to ensure the effectiveness of head restraints for tall occupants. At the second informal group meeting, the expert from the Netherlands pointed out that

the backset was not considered under the methods of the current UN Regulation No. 17; EuroNCAP and IIWPG proposed a new evaluation method that combines the height and backset. In this evaluation method, measurements are only performed at the centre of the head restraint. Measurements according to this evaluation method would require the height to be raised by approximately 40 mm. Some methodological issues were pointed out, such as remaining uncertainties, reproducibility/repeatability, and hindrance to rear visibility. At the fourth informal group meeting, the expert from the Netherlands explained the status of their consideration of new head restraint height requirements. The head restraint height would be considered by measuring the backset based on the 95 percentile HRMD template proposed by the expert from the Netherlands. The evaluation of effectiveness had been reported in the accident analysis by EEVC (HR-10-6). Japan pointed out that the evaluation method for active head restraints was necessary and that the timing of its delivery was important. The Chair noted that this topic could be developed in parallel to the principal issue of developing a procedure for the BioRID dummy. He encouraged the expert from the Netherlands to define their proposal as soon as possible and asked that he considered the effect that the most recent changes to regulatory requirements had on taller occupants. He also welcomed the cooperation between the International Organization of Motor Vehicle Manufacturers (OICA) and the Netherlands to collect data on the head position according to the Realistic Anthropological Mathematical Systems for Interior Comfort Simulation by June 2011.

153. At the sixth informal meeting, a proposal on "a simple, pragmatic approach to effective height measurement" was submitted by a task force led by the expert from the Netherlands and including experts from OICA. It was decided that the task force would study the new method further and the result of the study would be reported in June 2011.

154. At the seventh informal meeting, the head restraint height task force reported its proposed new height measurement method and explained measurement of the backset and effective height of head restraints for 50th percentile and 95th percentile occupants and the problem of possible interference between Child Restraint Systems (CRS) and rear head restraint. A new method for measuring the head restraint width was also proposed. The task force reported that, to further improve the measurement method, it would continue to study different head restraint designs as well as issues related to UN Regulation No. 16 (safety-belts) concerning the interference problem with CRS. The SAE Human Accommodations and Design Devices Committee had some comments on the head restraint height measurement method, and the Chair noted that SAE would be welcome to contribute to the work. It was also agreed that the task force would make the data obtained from this work available to NHTSA.

155. At the eighth IWG meeting, the expert from the Netherlands presented the proposed effective height measurement method with a proposal of text for the regulation. Annex 1 described the determination of the highest head restraint height at paragraph 2.3.3. as follows:

"2.3.3. Determination of the highest head restraint height

The head restraint height is the distance from the R-point, parallel to the torso reference line and limited by a line perpendicular to the torso reference line intersecting IP.

After the coordinates of IP are determined, the highest head restraint height can be calculated by its longitudinal (ΔX) and vertical (ΔZ) distance from the R-point, as follows:

Head restraint height = $\Delta X \cdot \text{SIN}(\text{design torso angle}) + \Delta Z \cdot \text{COS}(\text{design torso angle})$ "

The IWG discussed the proposed method of head restraint height measurement and noted some issues remained concerning certain head restraint shapes and the measurement device. The task force considered these issues and the IWG discussed them further at the following meeting.

156. At the fifty-first GRSP session, the expert from the Netherlands introduced a proposal to increase head restraint height (GRSP-51-24). The expert from OICA stated that the discussion should focus first on the definition of the measurement method and then on the height thresholds. GRSP agreed to resume discussion at its December 2012 session on the basis of a possible proposal of draft UN GTR No. 7, Phase 2 that may be submitted by IWG.

157. At the workshop held in March 2013 at Federal Highway Research Institute (BAST), the effective head restraint height measurement procedure was examined using a whole vehicle. The workshop outcomes are reflected in the text of Annex 1. The workshop also concluded that the backset could be measured without using an HRMD.

158. At the fifty-third GRSP meeting, the expert from the Netherlands proposed head restraint height requirements (GRSP-53-15) and GRSP resumed discussion at its December 2013 session on the draft proposal submitted by the experts from the Germany, the Netherlands and the United Kingdom.

159. At the fifty-fourth GRSP meeting, the expert from the United States of America questioned (GRSP-54-23) the rationale for both proposed height values. The expert from OICA observed (GRSP-54-18-Rev.1) that the new measurement procedure would reduce the measured height. GRSP agreed to resume consideration on this agenda item on the basis of a final proposal of draft amendment submitted by the IWG and of further justification (ECE/TRANS/WP.29/GRSP/2013/17).

160. At the fifty-eight GRSP meeting, the Netherlands informed GRSP that further improvements to the height measurement procedure of head restraint would be possible and withdrew document ECE/TRANS/WP.29/GRSP/2013/17. The proposal was further developed in the latest document ECE/TRANS/WP.29/GRSP/2015/34. The experts from Australia, China, Denmark, France, Germany, Hungary, Japan, the Netherlands, Republic of Korea, Sweden, Spain, United Kingdom, United States of America, Russian Federation and EC supported the proposal of a head restraint height requirement of 830 mm and 720 mm as proposed by the experts from the Netherlands, Germany and the United Kingdom, in reference to the 2007 EEVC study report. The experts from India stated that he could agree with the proposal on the condition that a footnote would allow contracting parties to restrict the requirements at the national level. Italy agreed with India on the higher height of head restraint. GRSP also adopted the proposal of the expert from OICA for the above-mentioned footnote as follow: "A contracting party may opt for a lower value in its domestic legislation if it decides that such value is appropriate". GRSP concluded that the head restraint heights of 830 mm and 720 mm respectively could be finalized. The IWG decided to review the proposal accordingly and where appropriate to adapt the height requirements. For the rear centre seat, it was decided to retain the height of 700 mm.

(b) **BioRID II**

(i) **List of items concerning BioRID II:**

161. Discussions on dummies had been conducted as part of the Global BioRID Users Meetings (GBUM) activities up to the first informal meeting. However, starting with

the second meeting, the GBUM activities were incorporated into those of the Informal Group's TEG (Technical Evaluation Group) who held web meetings approximately once a month.

(ii) **Biofidelity**

162. At the "meeting of interested experts", the current status of the study by EEVC Working Group 12 (WG12) and WG20 and the results of studies on the biofidelity of Hybrid III, Rear Impact Dummy (RID) 3D, and BioRID II were reported on. Biofidelity in volunteer tests at 7–9 km/h was verified using qualitative procedures and quantitative core method, and BioRID II presented the best results.

163. The expert from the United States of America reported on the progress of its studies on the biofidelity of dummies and injury mechanisms for the evaluation of AIS3+ injuries in mid- and high-speed rear impact crashes. Based on these results, a seat for sled tests was created. In addition, the biofidelity was compared with data from PMHS, BioRID, RID3D and Hybrid III experiments to determine the most appropriate dummy. The injury mechanisms were also examined to determine and verify the instrumentation to the spine and to define the injury behaviour.

164. At the fourth IWG meeting, the expert from NHTSA reported on the repeatability/reproducibility and biofidelity research. NHTSA had conducted dynamic tests at 17.6 and 24 km/h. NHTSA also conducted tests comparing PMHS with Hybrid III, BioRID, and RID3D. The dummies showed different biofidelity in head displacement and rotation during tests for reproducibility, repeatability and biofidelity. The ramping-up behaviour was quite different between PMHS and dummies. The evaluation of biofidelity and repeatability were planned for completion by the end of October and December 2010 respectively. NHTSA had also conducted tests to compare sensitivity and reproducibility among dummies. They compared the results using BioRID II and Hybrid III in seats with large and small backsets and waveforms as specified in FMVSS 202a and in a proposal to incorporate BioRID in UN Regulation No. 17. The purpose was to evaluate if the tests rank the severity of backset in the same manner. The testing was planned to be completed by November 2010 and the results to be presented in February 2011. OICA requested that a biofidelity assessment be conducted on the rear impact dummy chosen for this UN GTR, over the range of potential seatback angles.

165. One of the original tasks of the informal group was to develop a low-speed dynamic test, including the test procedure, compliance criteria and the associated corridors for the biofidelic rear impact dummy (BioRID II). As a possible later phase, depending upon the direction of WP.29, the group would consider the possibility of a higher-speed dynamic test.

166. At the fourth meeting, the Chair recalled that IWG was tasked to report to WP.29 at its 152nd session (November 2010), and specifically, to confirm the timetable for delivering a proposal for adopting the BioRID II dummy into UN GTR No. 7. He suggested recommending to WP.29 that the period for consideration of Phase 2 would be approximately two years, that the adoption by GRSP be in December 2012, that a proposal to WP.29 be in June 2013. The recommendation was based on the completion, as scheduled, of the research that was being conducted by the experts from Japan and the United States of America by the end of 2011, and moreover, on successfully establishing injury criteria suitable for evaluation in a regulatory test procedure.

167. Japan commented that BioRID II be added to the UN GTR in May 2011 as specified in the original ToR, since neck injury was a serious problem that needed to be addressed in the regulation immediately. Two options were proposed:

(a) **Option 1:** A proposal to amend UN GTR No. 7 that would be submitted to GRSP in May 2011 to specify dynamic backset evaluations using either Hybrid III or BioRID II, as a Contracting Party option. Then, as a second step, harmonization of the dummy, evaluation of upright postures, tests at higher speed and at mid-speed to be considered in 2014 and later.

(b) **Option 2:** Extend the work schedule of the informal group to require a proposal to amend UN GTR No. 7 to be submitted to GRSP in December 2012, in anticipation that a harmonized dynamic backset evaluation proposal would be made based on the injury criteria using BioRID II only. Then, as a second step, harmonization of the dummy, evaluation of upright postures, tests at higher speed and at mid-speed to be considered in 2014 and later.

168. OICA expressed strong concerns that both of these options would result in a UN GTR of choice by the Contracting Parties.

169. At the 152nd session of WP.29, the expert from Japan proposed a revision of the ToR to AC.3 that would establish the timeline of the group until 2012. This schedule should allow completion of the injury criteria analysis, but if the work was not complete, a detailed BioRID II test would be added to the UN GTR as an alternative to the existing test (the option already exists as a placeholder). The experts from the United States of America presented an alternative proposal which revised the ToR to allow the group to take a comprehensive approach in addressing both long-term and short-term minor neck injuries. AC.3 sent the proposals to GRSP, with a request for a revised proposal for the ToR at the 153rd session.

170. At the fifth meeting of the IWG it was confirmed that the group preferred to deliver a new proposal of a single procedure to assess protection against neck injury for integration into the UN GTR. The group also agreed with the recommendation of the expert from the United States of America that the injury criteria that emerge from the ongoing research effort in Japan and the United States of America should guide the development of the final procedure.

171. The expert from Japan showed associated lower-speed tests with injuries at the AIS1 level and said that any change to address more severe injury levels would take longer than December 2012. It was agreed that AIS1 injuries remain the focus but that, if possible, consideration would be given to long term as well as short term injuries.

172. Thus, the group recommended that GRSP amend the ToR to specify that the primary focus of the IWG should be developing a proposal for the BioRID II that would provide benefits that were equal or better than the benefits of the existing option in UN GTR No. 7. If the group was able to provide additional benefits within the specified time frame it would be permitted to do so, but if this work was not completed, any discussion of further work in this area would take place at a further stage.

173. At the sixth IWG meeting, the expert from the United States of America reported that BioRID II had the best biofidelity and reproducibility. The experts from Japan and the United States of America informed the IWG about the planned, joint study of the injury criteria by the end of 2011.

174. At the seventh IWG meeting, the expert from the Partnership for Dummy Technology and Biomechanics (PDB) reported that the shoulder of the BioRID II interacts with the seat back of the hard bucket seat depending on the seat back shape, with a load path via the T2 jacket bolt/shoulder plate; PDB also presented the simulation and sled test results that affect the upper neck Fx and My.

175. At the sixteenth IWG meeting, NHTSA reported on the significance of flexion in PHMS studies and, like HybridIII, the BioRID neck did not fully replicate this movement.

(iii) Dummy drawings (2D and 3D)

176. At the first and second IWG meetings, the progress of the drawing harmonization between Denton and First Technology Safety Systems (FTSS) was reported on. The 2D drawing (PDF form), 3D drawing (STEP form) and user's manual were scheduled to be drafted jointly by the two manufacturers.

177. By the fourth IWG meeting, Humanetics (formed by the merger of Denton and FTSS), had had the drawings posted on the GRSP website. They reported that 3D data was ready, but that the Procedures for Assembly, Disassembly, and Inspection (PADI) was under revision. They announced the preparation of the list, to be included in PADI, for checking the most recent dummy. The Chair of IWG pointed out that a method to clarify the suitability of the build level of BioRID II was needed. A suggestion from the expert of Japan to provide PADI along with drawings in a same website was agreed on.

178. At the 153rd session of WP.29, the Chair of IWG introduced a proposal for a protocol to manage drawings, manuals and specifications under WP.29 responsibilities. The basic principle was agreed on.

179. At the eighth IWG meeting, the Chair reported the status of the register of technical specifications. It was noted that WP.29 had decided, as a first step, that data had to be incorporated into the Consolidated Resolution on the Construction of Vehicles (R.E.3). The amendment to R.E.3 would also be used for other ATDs.

180. At the 158th session of WP.29, the World Forum and AC.3 adopted the M.R.1 of the 1958 and the 1998 Agreements which concerns the description and performance of test tools and devices.

181. At the fourteenth IWG meeting, PDB reported that the dummy drawing check was almost ready for incorporation into addendum 1. (M.R.1)

(iv) Certification procedures

182. At a "meeting of interested experts", the history of discussions on the new certification test at GBUM and the summary of those discussions were presented. The new certification test procedure were completed in Japan, the Republic of Korea, the United States of America and the European Union. The resulting sled test waveform had become flatter, showing good reproducibility. At the second IWG meeting, it was proposed to change the calibration waveform to match that of the EuroNCAP medium pulse and dummy input. However, the Chair commented that since the ToR of the informal group states that our objective is to specify the uniform method for evaluating low-speed impacts, and that the low speed is defined as V18 km/h or below, we should aim for a sled waveform around 16–18 km/h and discuss the calibration waveform based on the current proposal (GBUM2009).

183. At the third meeting, the BioRID TEG reported on the new certification test method with the head restraint. While developing in the right direction, there were concerns that the "head to head–restraint" contact time was too short (10–20 ms). Humanetics agreed to draft a detailed method for the head restraint calibration in the new sled. This was to be evaluated by Japan, Ford, General Motors (GM) and PDB.

184. At the fifth and sixth informal meetings, the calibration method without head restraints was agreed on. It was decided that the calibration with head restraints study would be based on the weight probe (119 kg) with a better correlation with input pulses of evaluation tests.

185. The jacket impact assessment was adopted as another improvement to dummy performance, while pelvis impact assessment was not considered to affect the dummy's effectiveness. The optional Skull CAP switch should be included in the drawing package.

186. At the seventh informal meeting, Humanetics reported on the results of certification tests using the standard probe and the heavy probe. They noted that none offered a clear benefit over the others, while the standard probe is better in terms of reduced burdens in handling in laboratories. The safe handling of such heavy tools was questioned.

187. At the eighth informal meeting, Japan reported that the Standard vs. Heavy probe calibration test results showed that with the heavy probe, the peak value and variation by calibration test had become more apparent.

188. At the fourteenth informal meeting, Humanetics reported on the recommended certification tests as follows:

- (a) Spine quasi-static setup;
- (b) Mini-sled without head restraint;
- (b) Mini-sled with seat back and head restraint;
- (c) Jacket only impact;
- (d) Pelvis only impact (bottom only).

And on the recommended inspection tests as follows:

- (a) Spine bumper stiffness;
- (b) Pelvis shape check.

189. At the informal meeting by WebEX in mid-November 2014, Humanetics reported progress on the dummy certification work and confirmed the ability of the new "Gen-X" test to discriminate dummy responses. They also reported progress on delivering material for Addendum I to the M.R.1. This will include, United Nations numbered drawings, and detailed text to describe the new "Gen-X" certification test.

(v) **Repeatability and Reproducibility**

190. In testing, good repeatability was obtained if the same dummy was used. However, there were problems with reproducibility among different dummies. Work to establish a common build level for BioRID II, together with dummy improvements and revised certification tests were being discussed to improve their repeatability and reproducibility.

191. At the third meeting, Japan reported on the results of the new dummy calibration methods and sled tests. The same variations in Lower Fz that had been seen in the new certification test method with the simulated head restraint were also observed in the sled tests. Accordingly, it was considered effective to use the head restraint in the certification test, especially to minimize variations around the contact time. However, there were differences in absolute values between certification and sled tests, and so further discussed in September 2010.

192. At the fourth IWG meeting, a quite large difference between sled types was reported when one seat was tested for evaluating the reproducibility using acceleration and deceleration sleds. It was difficult to keep the pulse within the corridor when using the deceleration sled. It was also pointed out that the backset changed due to the

movement of dummy head during approach. These issues would continue to be monitored.

193. At the seventh informal meeting, Korea Automobile Testing and Research Institute (KATRI) reported the results of dummy reproducibility in sled tests (with delta-v of 16 km/h and 20 km/h). Comparison of the values (CV) between the two sled speeds shows that, in general, CV was larger at 16 km/h than at 20 km/h, but it was also seen that the tendency was not the same for different evaluation areas. Injury values were not very reproducible, and it was decided to check the dummy specifications (2009–2010), to collect the latest findings and information obtained at this meeting, and to continue the study on reproducibility and repeatability. PDB re-adjusted the BioRID II that it had long used in testing, performed certification tests with the head restraint using the standard and heavy probes as well as verification tests with the accompanying hard bucket seat, and reported the results of these tests. As a result, it concluded that although the reproducibility/repeatability for accelerations was acceptable, the values were not adequate to be used as injury criteria for forces or moments — even though the dummy which satisfied testing with a hard bucket seat had shown poor reproducibility for some data channels. It was thus agreed that round-robin tests be performed between the United States of America and Europe with the dummy used in the PDB testing.

194. At the eighth IWG meeting, Humanetics reported on the round-robin test. Test results from Occupant Safety Research Partnership (OSRP) and Vehicle Research and Testing (VRTC) did not recreate the results recorded at PDB but OSRP did identify some reproducibility concerns. However, analysis of the results was not complete. The IWG would continue to investigate dummy reproducibility. The TEG Chair proposed a WebEX meeting as soon as possible, to schedule future work. The expert from Japan reported a BioRID response differentiation between dummy number 095G and dummies number 102G & 115 during calibration tests. By swapping the dummy jacket between 012G and 095, the waveform was shifted to correspond with the original dummy jacket's waveform. The expert from Japan would evaluate the jacket stiffness using the new procedures developed by Humanetics. The expert from the Republic of Korea reported their latest study of test procedure on the variation of dummy response by using FEM model and sled test. The expert from the Republic of Korea noted that the current low level of confidence in repeatability and reproducibility of real tests might be due to high tolerance of some factor of the dummy and considered that the current tolerance for the BioRID II setting should be reconsidered for establishing a test procedure in UN GTR 7, Phase2.

195. At the ninth IWG meeting, the Transport Research Laboratory reported the outcome of an EC study that evaluated the dummy reproducibility and repeatability using sled tests. The results indicated that some specific data channels do not provide adequate reproducibility (CV). The dummy response was sensitive to change which suggested that better certification tests and control of material properties might be needed. The spine bumper, jacket and pelvis flesh will be examined and the dummies refurbished. The refurbished dummies will be evaluated under the same sled test conditions.

196. At the eleventh informal meeting, Humanetics reported on the sled test results of the refurbished dummies. The results indicated better reproducibility with CV values but still needed data analysis. The TEG Chair proposed an additional sled test series with the European Commission (EC) project rig seat and PDB hard bucket seat. The test results were discussed at the subsequent IWG meeting in mid-February 2013.

197. At the BioRID TEG and IWG meeting, Chrysler reported the repeatability and reproducibility analysis from the EC project of dummy repeatability and

reproducibility, which showed that some channels are good and some poor. It was noted that the dummy components, jacket, pelvis and bumper had since been updated through validation tests and the analysis showed the dummy reproducibility had been improved (Series1, Series2).

198. At the fifteenth IWG meeting, Humanetics reported on the status of development of an update for the dummy certification tests and for the reproducibility issue. Humanetics reported that the stiffness of the candidate replacement materials for the spine bumper (Urethane rubber) in BioRID had proven unstable with ageing. He confirmed that all current testing proceeded by using matched and stable material and that new materials, when available, would be benchmarked against the original.

199. At the IWG meeting by WebEX in mid-November 2014, Humanetics reported that the dummy quality had improved as a result of the new procedures. Repeatability, reproducibility and C.V values were reported for several dummies. Matched dummies were identified for delivery to NHTSA (VRTC).

200. At the sixteenth informal meeting, NHTSA provided positive data for the repeatability and reproducibility of BioRID based on their latest sled test series.

(vi) Dummy seating conditions

201. At a "meeting of interested experts" and at the first informal meeting on the seating procedures of IIWPG and EuroNCAP, Japan made proposals on:

- (a) Design reference torso angle;
- (b) Reduction of backset tolerance; and
- (c) Special adjustment in the case of smaller torso angle (more upright) seats typically used in small N₁ vehicles (especially those with forward control).

And explained the reasons for the proposals (GTR7-01-09e).

202. At the second IWG meeting, the expert from Japan reported that, in general, the torso angle was about 15° in trucks and vans, and it proposed to specify an optional spine angle to accommodate these upright seats. Denton, Inc. (now part of Humanetics) presented a new spine shape former (comb) to set the dummy in a more erect seating posture. The appropriateness of the dummy when set to this posture was being evaluated.

203. At the third IWG meeting, basic agreement was reached on adopting the design reference angle proposed by the expert from Japan for the standard (recumbent) seating posture.

204. The expert from Japan reported on the influence of the difference of seating postures at the design torso angle and 25° angle. They reported no specific differences between two of the same seats with tested with the conditions of JNCAP (design angle, 20°–25° angle) or IIHS (25° angle).

205. The expert from Japan reported on the results of tests that it had conducted to study the new tool for upright postures using a smaller torso angle (10°) for commercial vehicles. While the dummy spine could be set to the revised posture when the dummy was equipped with its jacket, its upright posture would tilt the dummy forward significantly and it was not possible to keep the dummy head fully horizontal. For this reason, it was decided that, applying the upright posture tool, development of the jacket, etc. would be undertaken as a second step.

206. The experts from Japan and OICA reported on the ratio of seats with upright torso angle in the market. The expert from Japan reported that such seats account for

45 per cent of all seats in the Japanese market and pointed out the necessity of a static backset option until the dummy is developed for use with an upright posture.

207. The expert from OICA reported that the overall worldwide percentage (which includes the Japanese data) of seats with upright torso angle is 12 per cent.

208. It was agreed that work to define procedures to assess more upright seats would not be pursued as a priority at this time but that the static evaluation procedure was kept as an option for these seats until the dynamic evaluation was shown to be suitable for all seat angles.

2.09. At the workshop held in July 2013 at BAST, the BioRID seating procedure examined different torso angle conditions. However, it was noted that the dummy spine flexibility might, during setting up, lead to position variations. The seating procedure continued to be investigated by the experts from OICA with the intention that the dummy seating procedure and appropriate dummy positioning tolerances would be suggested in the near future.

210. At the fifteenth IWG meeting, the expert from the Japan Automobile Manufacturers Association (JAMA) reported on the study of the dummy seating procedure for the dynamic test. The study indicated that it was better to set the pelvis angle at $26.5^\circ \pm 2.5^\circ$ and hip point tolerance(z) 0 ± 10 mm in dynamic tests using production seats. JAMA indicated that their work was continuing.

(vii) Dummy Durability

211. The neck damper was damaged during the new calibration test procedures in the Republic of Korea. Ford pointed out that it was necessary to add a body block to the calibration sled to prevent damage to dummies.

212. At the fourth IWG group meeting, it was agreed that the issue experienced by the Republic of Korea had not been seen elsewhere and it was not considered to be a problem.

(viii) Specifications

213. BioRID tests exhibited good repeatability in a number of studies. However, problems were identified in reproducibility among different dummies. The generic build level according to commercial identification did not adequately specify the tool and a specific build level was established: BioRID II, along with dummy improvements.

214. European Commission research showed that differences in the measured values from different BioRID ATD could be associated with the torso flesh, i.e. when swapping the flesh between ATD the resulting values changed accordingly. The research also recommended an evaluation of the contribution of BioRID's intervertebral bumpers.

215. Insert an additional section on control of materials, e.g. pelvis and torso flesh, spine bumpers, etc. [To be added]

(ix) Limitations

216. The spine curvature of BioRID was established using a shape former (comb) during its assembly. This curvature essentially determines the device's posture. The IWG had based its evaluation work on the most recumbent posture of the two defined build options as this covers the majority of vehicle seats in the market.

217. While evaluation had not been made of the recumbent device's repeatability and reproducibility when used in very upright vehicle seats, certain limitations were recognised even in a static condition, e.g. the stability of the head.

218. The use of BioRID was therefore limited, in the context of this UN GTR, for use

with seat back angles between 20° and 30°.

219. The repeatability and reproducibility studies were completed exclusively using acceleration sleds (those that are accelerated from rest by the application of a sudden force). Annex 9 of this UN GTR contains procedures for the BioRID dummy using an acceleration sled only.

(c) **Backset measurement method**

220. Measurement of Backset using coordinate measuring apparatus. [To be added]

(d) **Lead time**

221. It is recommended that the Contracting Parties which implement this UN GTR allow adequate lead time before full mandatory application and give consideration to the necessary vehicle development time and product lifecycle."

Part B, Text of the Regulation, renumber as II and amend to read:

"II. Text of the Regulation

1. Purpose

This Regulation specifies requirements for head restraints to reduce the frequency and severity of injuries caused by ~~rearward displacement of the head~~ **relative motion of the head, the neck, and the torso resulting from rear impact.**

2. Application / Scope

This Regulation applies to all Category 1-1 vehicles; Category 1-2 vehicles with a Gross Vehicle Mass of up to 4,500 kg; and Category 2 vehicles with a Gross Vehicle Mass of up to 4,500 kg. ¹

3. Definitions

- 3.1. "*Adjustable head restraint*" means a head restraint that is capable of movement independent of the seatback between at least two positions of adjustment intended for occupant use.
- 3.2. "*Backlight*" means rearward-facing window glazing located at the rear of the roof panel.
- 3.3. "*Backset*" means the horizontal distance between the front surface of the head restraint and the rearmost point of the head ~~restraint measurement device, as measured in accordance with Annex 4 or Annex 5.~~
- 3.3.1. "*R-point Backset*" means the backset as measured in accordance with Annex 4.
- 3.3.2. "*BioRID Reference Backset*" means the backset as determined in accordance with Annex 8.
- 3.4. "*Head restraint*" means, at any designated seating position, a device that limits rearward displacement of a seated occupant's head relative to the occupant's torso and that has a height equal to or greater than 700 mm at any point between two vertical longitudinal planes passing at 85 mm on either side of the torso line, in any position of backset and height adjustment, as measured in accordance with Annex 1.

¹ As defined in Special Resolution No. 1 concerning the common definitions of vehicle categories, masses and dimensions (S.R.1) document, TRANS/WP.29/1045 and Amend. 1, Annex 2, para. 1.

www.unece.org/trans/main/wp29/wp29wgs/wp29gen/wp29resolutions.html

A contracting party may restrict application of the requirements in its domestic legislation if it decides that such restriction is appropriate.

- ~~3.5.~~ "~~Head restraint measurement device (HRMD)~~" means a separate head shaped device used with the H-point machine with the head form, as defined in Annex 4, attached with sliding scale at the back of the head for the purpose of measuring backset.²
- ~~3.6.~~ **3.5.** "*Three-dimensional H-point machine*" (H-point machine) means the device used or the determination of "H-points" and actual torso angles. This device is defined in Annex ~~13~~**12**.
- ~~3.7.~~ **3.6.** "*Head restraint height*" means the distance from the R-point, measured parallel to the torso line **to the effective top (IP)** of the head restraint on a plane normal to the torso line.
- ~~3.8.~~ **3.7.** "*Intended for occupant use*" means, when used in reference to the adjustment of a seat and head restraint, adjustment positions used by seated occupants while the vehicle is in motion, and not those intended solely for the purpose of allowing ease of ingress and egress of occupants; access to cargo storage areas; and or storage of cargo in the vehicle.
- ~~3.9.~~ **3.8.** "*H-point*" means the pivot centre of the torso and thigh of the H-point machine when installed in a vehicle seat in accordance with Annex ~~12~~**11**. Once determined in accordance with the procedure described in Annex ~~12~~**11**, the "H" point is considered fixed in relation to the seat-cushion structure and is considered to move with it when the seat is adjusted **in the X direction**.
- ~~3.10.~~ **3.9.** "*R-point*" means a design point defined by the vehicle manufacturer for each designated seating position and established with respect to the three-dimensional reference system as defined by Annex ~~11~~**10**. The R-point is **defined in Annex 10 and:**
- ~~3.10.1.~~ **3.9.1.** Establishes the rearmost normal design driving or riding position of each designated seating position in a vehicle;
- ~~3.10.2.~~ **3.9.2.** Has coordinates established relative to the designed vehicle structure;
- ~~3.10.3.~~ **3.9.3.** Simulates the position of the centre pivot of the human torso and thigh;
- ~~3.10.4.~~ **3.9.4.** Is defined in Annex ~~12~~**11** of this regulation.
- 3.10.** "*R₅₀-point*" means a design point defined by the vehicle manufacturer for the seated 50th percentile male for the designated seating position.
- ~~3.11.~~ "~~Top of the head restraint~~" means the point on the head restraint centreline with the greatest height.
- "*Effective top of the head restraint*" means the highest point on the centreline of the head restraint, determined in accordance with Annex 1 and is designated as intersection point (IP).
- ~~3.12.~~ "*Torso line*" means the centreline of the probe of the H-point machine with the probe in the fully rearward position.
- ~~3.13.~~ "*Actual torso angle*" means the angle measured **using the H-point machine** between a vertical line through the H-point and the torso line using the back angle quadrant on the H-point machine. ~~The actual torso angle corresponds theoretically to the design torso angle.~~

² ~~The technical specifications and detailed drawings of HRMD, are deposited with the Secretary General of the United Nations and may be consulted on request at the secretariat of the UNECE, Palais des Nations, Geneva, Switzerland.~~

- 3.14. "*Design torso angle*" means the angle measured **with the H-Point machine** between a vertical line through the R-point and the torso line in a position which corresponds to the design position of the seat back ~~established~~ **specified** by the vehicle manufacturer.
- 3.15. "*Longitudinal plane*" means any plane parallel to the vertical longitudinal zero plane of the vehicle, as defined in Annex 10.
- 3.16. "*Rebound*" means ~~that the head bounced back after contacting the head restraint.~~ **the movement of the head after contact with the head restraint (i.e. times after T-HRC(end))**
- 3.17. **"Side bolster" means adjustable seat elements on the sides of the seat cushion and / or of the seat back in order to allow a lateral retention of the occupant.**

4. General requirements

- 4.1. Whenever a range of measurements is specified, the head restraint shall meet the requirement at any position of adjustment intended for occupant use.
- 4.2. In each vehicle subject to the requirements of this Regulation, a head restraint shall be provided at each front outboard designated seating position, conforming to either paragraph 4.2.1. or paragraph 4.2.2. **at the choice of the manufacturer.**
- 4.2.1. The head restraint shall conform to paragraphs 5.1., 5.2., 5.4., and 5.5. of this Regulation.
- 4.2.2. The head restraint shall conform to paragraphs 5.1.1. to 5.1.4., 5.3., 5.4., and 5.5. of this Regulation.
- 4.3. For vehicles equipped with rear outboard and/or front centre head restraints, the head restraint shall conform to either paragraph 4.3.1. or paragraph 4.3.2. **at the choice of the manufacturer.**
- 4.3.1. The head restraint shall conform to paragraphs 5.1.1. to 5.1.4., 5.2., 5.4., and 5.5. of this Regulation.
- 4.3.2. The head restraint shall conform to paragraphs 5.1.1. to 5.1.4., 5.3., 5.4., and 5.5. of this Regulation.
- 4.4. For vehicles equipped with rear centre head restraints, the head restraint shall conform to either paragraph 4.4.1. or 4.4.2. **at the choice of the manufacturer.**
- 4.4.1. The head restraint shall conform to paragraphs 5.1.2. to 5.1.4., 5.2., 5.4., and 5.5. of this Regulation.
- 4.4.2. The head restraint shall conform to paragraphs 5.1.2. to 5.1.4., 5.3., 5.4., and 5.5. of this Regulation.
- 4.5. This Regulation does not apply to auxiliary seats such as temporary or folding jump seats or to side-facing or rear-facing seats.
- 4.6. At designated seating positions incapable of seating the test dummy specified in paragraph 5.3. of this Regulation, the applicable head restraint shall conform to either paragraph 4.2.1., or 4.3.1, or 4.4.1. of this Regulation, as appropriate.

5. Performance requirements

5.1. Dimensional requirements

5.1.1. ~~Minimum~~ Height requirements for the highest and lowest use positions

5.1.1.1. General specifications

The following requirements on ~~minimum~~ height shall be demonstrated in accordance with Annex 1.

5.1.1.2. Front outboard designated seating positions

The ~~top height~~ **height** of a head restraint located in a front outboard designated seating position shall, except as provided in paragraph 5.1.1.4. of this Regulation, ~~have a height of~~ **be**:

- (a) not less than ~~800~~ **830**³ mm in at least one position of head restraint adjustment, and
- (b) not less than ~~750~~ **720** mm in any position of head restraint adjustment.

5.1.1.3. Front centre designated seating positions equipped with head restraints

The ~~top height~~ **height** of a head restraint located in the front centre designated seating position shall ~~have a height of~~ **be** not less than ~~750~~ **720** mm in any position of adjustment, except as provided in paragraph 5.1.1.4. of this Regulation.

5.1.1.4. Exception (should this be a sub para to 5.1.1.3?)

~~The top of a head restraint located in a front outboard designated seating position shall have a height of not less than 700 mm when the head restraint is adjusted to its lowest position intended for occupant use; if the interior surface of the vehicle roofline, including the headliner, physically prevents a head restraint, located in the front designated seating position, from attaining the height required by paragraphs 5.1.1.2. and or 5.1.1.3. of this Regulation as applicable, the gap between the head restraint and the interior surface of the roofline, including the headliner, when measured in accordance with Annex 1, paragraph 2.3.3.1., shall not exceed 50 mm when the head restraint is adjusted to its highest position intended for occupant use. However, in no instance shall the height of a head restraint located in a front designated seating position be less than 700 mm when the head restraint is adjusted to its lowest position intended for occupant use. In those instances, the vertical distance between the top of the head restraint and the interior surface of the roofline, including the headliner, shall not exceed 50 mm for convertibles and 25 mm for all other vehicles, when the head restraint is adjusted to its highest position intended for occupant use.~~

5.1.1.5. Rear outboard designated seating positions equipped with head restraints

The ~~top height~~ **height** of a head restraint located in a rear outboard designated seating position shall have a height of not less than ~~750~~ **720** mm in any position of adjustment, except as provided in paragraph 5.1.1.6. of this Regulation.

5.1.1.6. Exception (again sub para?)

³ A contracting party may opt for a lower value in its domestic legislation if it decides that such value is appropriate.

~~The requirements of paragraph 5.1.1.5. of this Regulation do not apply~~ If the interior surface of the vehicle roofline, including the headliner, or backlight physically prevent a head restraint, located in the rear outboard designated seating position, from attaining the ~~required height. In those instances, the maximum vertical distance between the top of~~ **height required by paragraph 5.1.1.5. of this Regulation, the gap between** the head restraint and interior surface of the roofline, including the headliner, or the backlight **when measured in accordance with Annex 1, paragraph 2.3.3.1.,** shall not exceed 50 mm for convertibles and 25 mm for all other vehicles, when the head restraint is adjusted to its highest position intended for occupant use.

5.1.2. Minimum width

When measured in accordance with Annex 2, the lateral width of a head restraint shall be not less than 85 mm on either side of the torso line (distances L and L' ~~measured as per Annex 2).~~

5.1.3. Gaps within head restraint

If a head restraint has any gap greater than 60 mm when measured in accordance with Annex 3, the maximum rearward displacement of the head form shall be less than 102 mm when the head restraint is tested at that gap in accordance with Annex 65.

5.1.4. Gaps between head restraint and the top of the seat back

When measured in accordance with Annex 3, there shall not be a gap greater than 60 mm between the bottom of the head restraint and the top of the seat back if the head restraint cannot be adjusted in height.

In the case of head restraints adjustable in height to more than one position intended for occupant use, when measured in accordance with Annex 3, there shall not be a gap greater than 25 mm between the bottom of the head restraint and the top of the seat back, with the head restraint adjusted to its lowest height position.

5.1.5. Backset requirements

5.1.5.1. General specifications

5.1.5.1.1. Head restraints on the front outboard designated seating positions shall meet the backset requirements of paragraph 5.1.5.2.

5.1.5.2. Static maximum backset requirements

5.1.5.2.1. For height adjustable head restraints, the requirements shall be met with the **effective** top of the head restraint in all height positions of adjustment between ~~750~~ **720** mm and ~~800~~ **830**³ mm, inclusive. If the **effective** top of the head restraint, in its lowest position of adjustment, is above ~~800~~ **830**³ mm, the requirements of this regulation shall be met at that position only.

For head restraints that are adjustable in the longitudinal plane of the vehicle, the maximum backset requirement shall be achieved in any position of the available backset adjustment.

5.1.5.2.2. When measured in accordance with Annex 4, the backset shall not be more than ~~55 mm~~ **45mm**. ~~Based on a determination by each Contracting Party or regional economic integration organization, the manufacturer may be allowed the option to measure in accordance with Annex 5 as an alternative, in which case the backset shall not be more than 45 mm.~~

- 5.1.5.2.3. ~~In the case of Annex 4, If the front outboard head restraint is not attached to the seat back, it shall not be possible to adjust the seat or head restraint such that the backset is more than 55 mm~~ 45 mm. ~~when the seat back inclination is positioned closer to vertical than the position specified in Annex 4.~~
- 5.1.5.2.4. ~~The above requirements on maximum backset shall be demonstrated by taking the arithmetic mean of 3 measurements obtained in accordance with Annex 4 or Annex 5.~~
- 5.2. Static performance requirements
- Each head restraint shall conform to paragraphs 5.2.1. to 5.2.4. of this Regulation.
- 5.2.1. Energy absorption
- When the front surface of the head restraint is impacted in accordance with Annex 76, the deceleration of the head form shall not exceed 785 m/s² (80g) continuously for more than 3 milliseconds.
- 5.2.2. Adjustable head restraint height retention
- When tested in accordance with Annex 87, the mechanism of the adjustable head restraint shall not fail in such a way as to allow downward movement of the head restraint by more than 25 mm.
- 5.2.3. Displacement and backset retention
- 5.2.3.1. General Specifications
- 5.2.3.1.1. In the case of head restraints with an adjustable backset, the head restraint shall conform to the displacement and backset retention requirements of paragraph 5.2.3.2. of this Regulation. However, based on the determination of each Contracting Party or regional economic integration organization, the manufacturer may be allowed to apply the displacement requirements of paragraph 5.2.3.3. as an alternative.
- 5.2.3.1.2. All other head restraints shall conform to the displacement requirements of paragraph 5.2.3.3.
- 5.2.3.2. Displacement and backset retention
- 5.2.3.2.1. When the head restraint is tested in any position of backset adjustment in accordance with Annex 65, the head form shall:
- 5.2.3.2.1.1. Not be displaced more than 25 mm during the application of the initial reference moment of 37 Nm;
- 5.2.3.2.1.2. Not be displaced more than 102 mm perpendicularly and rearward of the displaced extended torso line during the application of a 373 Nm moment about the R-point; and
- 5.2.3.2.1.3. Return to within 13 mm of its initial reference position after the following sequence occurs: application of a 373 Nm moment about the R-point; reduction of the moment to 0 Nm; and by re-application of the initial reference load 37 Nm.
- 5.2.3.3. Displacement
- 5.2.3.3.1. When the head restraint is tested in the rearmost (relative to the seat) position of horizontal adjustment (if provided) in accordance with Annex 65, the head form shall not be displaced more than 102 mm perpendicularly and rearward

of the displaced extended torso line during the application of a 373 Nm moment about the R-point.

5.2.4. Head restraint strength

When the head restraint is tested in accordance with Annex 65, the load applied to the head restraint shall reach 890 N and remain at 890 N for a period of 5 seconds.

5.3. Dynamic performance requirements

5.3.1. Based on a determination by each Contracting Party or regional economic integration organization, either a Hybrid III 50th percentile male dummy ⁴ or a BioRID II 50th percentile male dummy shall be used to determine compliance. If a Hybrid III dummy is used, the head restraint shall meet the requirements of paragraph 5.3.2. If a BioRID II dummy is used, the head restraint shall meet the requirements of paragraph 5.3.3.

5.3.2. Hybrid III Requirements

5.3.2.1. When tested during forward acceleration of the dynamic test platform, in accordance with Annex 98, at each designated seating position equipped with a head restraint, the head restraint shall conform to paragraphs 5.3.2.2. and 5.3.2.3.

5.3.2.2. Angular rotation

Limit the maximum rearward angular rotation between the head and torso of the 50th percentile male Hybrid III test dummy to 12° for the dummy in all outboard designated seating positions.

5.3.2.3. Head injury criteria

Limit the maximum HIC15 value to 500. HIC15 is calculated as follows: For any two points in time, t_1 and t_2 , during the event which are separated by not more than a 15 millisecond time interval and where t_1 is less than t_2 , the head injury criterion (HIC15) is determined using the resultant head acceleration at the centre of gravity of the dummy head, a_r , expressed as a multiple of g (the acceleration of gravity) and is calculated using the expression:

$$HIC = \left[\frac{1}{(t_2 - t_1)} \int_{t_1}^{t_2} a_r dt \right]^{2.5} (t_2 - t_1)$$

5.3.3. BioRID II Requirements

~~Reserved: Until BioRID II requirements are included in this Regulation or adopted in the national Regulation of a Contracting Party or regional economic integration organization, head restraints shall comply with either paragraph 5.3.3.1. or 5.3.3.2. as appropriate.~~

Until further evaluation is conducted, the use of the BioRID II dummy shall be limited to seats having a torso angle between 20° and 30°. However, at the manufacturer's request, seats with a torso angle between

⁴ The technical specifications and detailed drawings of Hybrid III dummy, corresponding to the principal dimensions of a 50th percentile male of the United States of America, and the specifications for its adjustment for this test are deposited with the Secretary-General of the United Nations and may be consulted on request at the secretariat of the ECE, Palais des Nations, Geneva, Switzerland.

15° and 20° may be tested as if the torso angle is 20°, if it is possible to adjust the torso angle at 20° or the closest locking position above.

5.3.3.1. ~~Based on a determination by each Contracting Party or regional economic integration organization, dynamic head restraints shall comply with any or all of the items contained in paragraph 5.2.~~

Each head restraint, when tested during forward acceleration of the dynamic test platform, using BioRID II 50th percentile male dummy⁵ in accordance with Annex 8, shall conform to the requirements of paragraph 5.3.3.2.

⁵ The technical specifications and detailed drawings of BioRID II dummy, corresponding to the principal dimensions of a 50th percentile male of the United States of America, and the specifications for its adjustment when used for the purpose of this Regulation are recorded in Addendum I to Mutual Resolution No. 1, TRANS/WP.29/1101/Add.1 of the 1958 and 1998 Agreements.

5.3.3.2. All other head restraints shall meet the requirements of either paragraph 4.2.1, 4.3.1, or 4.4.1, as appropriate.

Evaluation Criteria

Each head restraint shall control the movement of the head and neck within the following limits:

<i>{-AIS1+; 50% Value</i>		
<i><Equivalence> WAD2+</i>		
IV-NIC=1.1}		
<i>Injury Criteria</i>		
NIC Max		25 m²/s²
Upper Neck	FX	360 N
	MY(Flx/Ext)	30 Nm
Lower Neck	FX (Backward)	360 N
	MY(Flx/Ext)	30 Nm

~~Note: The injury criteria shall be calculated excluding rebound movement of the head. For the injury criteria of upper and lower neck shear force, both the positive and negative values as defined in Annex 8, paragraph 4.4.2, shall be used.~~

Injury Criteria		
	NIC Max	25 m²/s²
Upper Neck	FX	360 N
	MY(Flx/Ext)	30 Nm
Lower Neck	FX	Remove. Going forward possible plan to Monitor and add preamble text.
	MY(Flx/Ext)	30 Nm

Note: The injury criteria shall be calculated excluding rebound movement of the head. For the injury criteria of upper and lower neck, both the positive and negative values shall be assessed.

5.4. Non-use positions

5.4.1. A driver head restraint shall not have a non-use position.

- 5.4.2. A front outboard passenger head restraint may be adjusted to a position at which its height does not comply with the requirements of paragraph 5.1.1.2. of this Regulation. However, in any such position, the front outboard passenger head restraint shall meet paragraph 5.4.4.1. of this Regulation.
- 5.4.3. All rear head restraints and any front centre head restraint may be adjusted to a position at which their height does not comply with the requirements of either paragraph 5.1.1.3. or 5.1.1.5. of this Regulation. However, in any such position, the head restraint shall also meet one additional requirement from a set of several alternative test requirements.
- The set of alternative test requirements may be, at the choice of the manufacturer either paragraph 5.4.4.1., or 5.4.4.2., or 5.4.4.3., or 5.4.4.4. of this Regulation.
- Based on a determination by each Contracting Party or regional economic integration organization, the manufacturer may also be allowed to choose paragraph 5.4.4.5. of this Regulation as an alternative to paragraphs 5.4.4.1. to 5.4.4.4.
- 5.4.4. Alternative requirements
- All of the items described in paragraphs 5.4.4.1. to 5.4.4.5. are permitted as ~~additional features.~~
- 5.4.4.1. In all designated seating positions equipped with head restraints, except the driver's designated seating position, the head restraint shall automatically return from a non-use position to a position in which its minimum height is not less than that specified in paragraph 5.1.1. of this Regulation when a 5th percentile female Hybrid III test dummy ⁶ is positioned in the seat in accordance with Annex ~~109~~. At the option of the manufacturer, instead of using a 5th percentile female Hybrid III test dummy, human beings may be used as specified in Annex ~~109~~.
- 5.4.4.2. In front centre and rear designated seating positions equipped with head restraints, the head restraint shall, when tested in accordance with Annex ~~109~~, be capable of manually rotating either forward or rearward by not less than 60° from any position of adjustment intended for occupant use in which its minimum height is not less than that specified in paragraph 5.1.1. of this Regulation. **A head restraint rotated by a minimum of 60° forward or rearward, shall be considered to be placed in a non-use position even if the head restraint height in such a position would be greater than that specified in paragraph 5.1.1.**
- 5.4.4.3. When measured in accordance with Annex ~~109~~, the lower edge of the head restraint (HLE) shall be not more than 460 mm, but not less than 250 mm from the R-point and the thickness (S) shall not be less than 40 mm.
- 5.4.4.4. When tested in accordance with Annex ~~109~~, the head restraint shall cause the **actual** torso ~~line~~ angle to be at least 10° ~~less~~ ~~closer to vertical~~ than when the

⁶ The technical specifications and detailed drawings of Hybrid III dummy, corresponding to the principal dimensions of a 5th percentile female of the United States of America, and the specifications for its adjustment for this test are deposited with the Secretary-General of the United Nations and may be consulted on request at the secretariat of the ECE, Palais des Nations, Geneva, Switzerland.

head restraint is in any position of adjustment in which its height is not less than that specified in paragraph 5.1.1. of this Regulation.

- 5.4.4.5. The head restraint shall be marked with a label in the form of a pictogram which may include explanatory text. The label shall either provide an indication when the head restraint is in a non-use position or provide information to enable an occupant to determine whether the head restraint is in a non-use position. The label shall be durably affixed and located such that it is clearly visible by an occupant when entering the vehicle to the designated seating position.

Examples of possible designs of pictograms are shown in Figure 1.

Figure 1

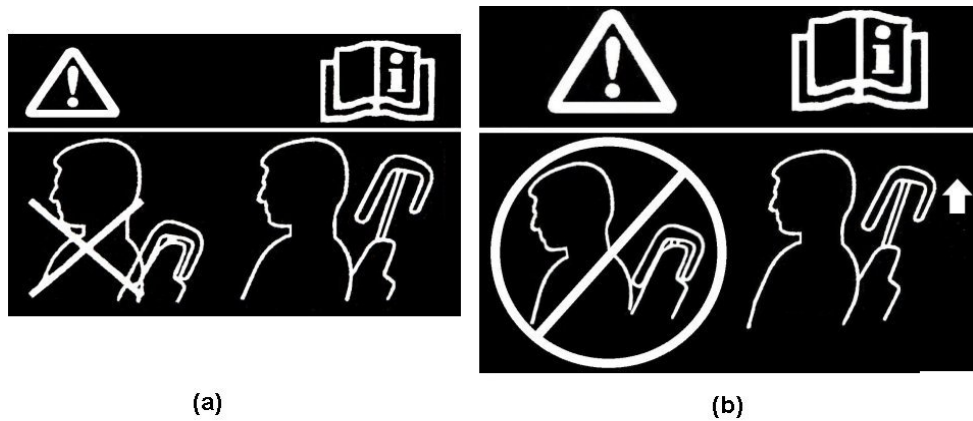

- 5.5. Removability of head restraints

The head restraints shall not be removable without a deliberate action distinct from any action necessary for upward head restraint adjustment.

6. Test conditions

The test procedures described in the following annexes are to be performed using any or all of the following:

- 6.1. A full vehicle including at least the seat to be tested and all necessary seat and head restraint equipment.
- 6.2. A vehicle body in white including at least the seat to be tested and all necessary seat and head restraint equipment as well as all necessary equipment **for the activation of dynamic head restraints. Where a manufacturer requests, a seat belt, equivalent to that used in the vehicle, and its anchorages may be used. This does not make sense, not sure what it is trying to say.**
- 6.3. **Where the performance of the seat is assessed independent of the vehicle,** a seat equipped with its head restraint and all necessary attachment hardware, as well as all necessary equipment for the activation of dynamic head restraints. **Where a manufacturer requests, a seat belt, equivalent of that used in the vehicle, and its anchorages may be used. Same as above**

Annex 1

Minimum Height measurement test procedure

1. Purpose

The purpose of this test procedure is to demonstrate compliance with the ~~minimum~~ height requirements described in paragraph 5.1.1. of this Regulation.
2. Procedure for height measurement

Compliance with the requirements of paragraph 5.1.1. of this Regulation is demonstrated by using the height measurement ~~apparatus~~ **procedure** defined in paragraphs 2.2. and 2.3. below.

~~The seat is adjusted such that its H-point coincides with the R-point; if the seat back is adjustable, it is set at the design seat back angle; both of these adjustments are in accordance with the requirements of paragraph 2.1. below. The height of the head restraint is the distance between point A and the intersection of lines AE and FG.~~

 - 2.1. Relationship between the H-point and the R-point

~~When the seat is positioned in accordance to the manufacturer's specifications, the H-point, as defined by its coordinates, shall lie within a square of 50 mm side length with horizontal and vertical sides whose diagonals intersect at the R-point, and the actual torso angle is within 5 degrees of the design torso angle.~~

 - ~~2.1.1. If these conditions are met, the R-point and the design torso angle are used to determine the height of the head restraints in accordance with this Annex.~~
 - ~~2.1.2. If the H-point or the actual torso angle does not satisfy the requirements of paragraph 2.1., the H-point and the actual torso angle are determined twice more (three times in all). If the results of two of these three operations satisfy the requirements, the conditions of paragraph 2.1.1. shall apply.~~
 - ~~2.1.3. If the results of at least two of the three operations described in paragraph 2.1.2. do not satisfy the requirements of paragraph 2.1. the centroid of the three measured points or the average of the three measured angles is used and be regarded as applicable in all cases where the R-point or the design torso angle is referred to in this Annex.~~

The seat is adjusted such that its H-point coincides with the R-point; if the seat back is adjustable, it shall be adjusted to the seat back inclination corresponding to the design torso angle; the relationship between the H-point and the R-point shall be in accordance with the requirements of Annex 4, paragraph 2.2.1.

If, elsewhere during head restraint testing, the H-point and/or actual torso angle have not been found in accordance with Annex 4, paragraph 2.1.1. but consequently paragraph 2.1.3. or paragraph 2.1.4. of Annex 4 have been applied, then the check on the relationship shall not be repeated for the height measurement.
 - 2.2. Height measuring apparatus

The height measurement ~~apparatus~~ consists of (see Figure 1-1): **shall be based on the use of an apparatus that facilitates the measurement of coordinates.**

~~2.2.1. A straight edge AE. The lower point A is placed at the R point location in accordance with paragraph 2.1. of this Annex. The line AE is parallel to the design torso angle.~~

~~2.2.2. A straight edge FG, perpendicular to the line AE and in contact with the top of the head restraint. The height of the head restraint is the distance between point A and the intersection of the lines AE and FG.~~

2.3. Height measurement for front outboard head restraints

All measurements shall be taken in the median longitudinal plane of the designated seating position.

2.3.1. ~~If adjustable, adjust the top of the head restraint to the highest position and measure the height.~~

~~If adjustable, adjust the top of the head restraint to the lowest position intended for normal use, other than any non-use position described in paragraph 5.4. of this Regulation, and measure the height.~~

Determination of contact point (CP) (see Figure 1-1)

Adjust the head restraint to the position intended for use by the mid-sized male¹, as specified by the manufacturer. In the absence of any specification, the head restraint shall be adjusted as close as possible to the mid-position. If two positions of adjustment are equidistant from the mid-position, the head restraint shall be adjusted to the higher of the mid-position and/or rear of the mid-position.

For head restraints not adjustable for height, the fixed position shall be used.

If there is only one in-use position, this shall be treated as a head restraint which is not adjustable for height.

The CP is defined as the intersection of a horizontal line, on the height of the Z-coordinate of the back-of-head of the mid-sized male (as given in table 1), with the front surface of the head restraint as indicated in Figure 1-1.

Once established, the point CP is a virtual seat reference point (x and z coordinates).

Where CP cannot be determined because the horizontal line through the back-of-head of the mid-sized male is located above the head restraint, the head restraint must be raised to the next locking position to enable the determination of point CP.

In the instance where this will not produce a point of intersection, the CP will be designated at the horizontal top of the head restraint. The horizontal top of the head restraint being defined as the uppermost point on the head restraint, which is determined by lowering a horizontal line in the median longitudinal plane of the designated seating position until it touches the head restraint (see Figure 1-4). Where more points are located at the same height, the longitudinally forward most point of the horizontal top of the head restraint is designated as CP.

***Note:* This paragraph 2.3.1. describes only CP.**

¹ The back-of-head of the mid-sized male is represented by the HRMD attached to the three-dimensional H-point machine, as well as by the Torso and Neck Link with the head room probe fitted 71 mm rearwards (see Figure 1-1)

Where CP cannot be determined because the horizontal line through the back-of-head of the mid-sized male is on the level of a gap within the head restraint, CP will be determined using a 165 mm diameter sphere with its centre at the same height level as the horizontal line through the back-of-head of a mid-sized male.

When the sphere is making first contact with the head restraint, the CP is designated as the rearmost point of the sphere in the gap area (see Figure 1-5).

- 2.3.2. For front outboard head restraints that are prevented by the interior surface of the vehicle roofline from meeting the required height as specified in paragraph 5.1.1.2. of this Regulation, the requirements of paragraph 5.1.1.4. of this Regulation are assessed by the following procedure:
- 2.3.2.1. Adjust the head restraint to its maximum height and measure the clearance between the top of the head restraint and the interior surface of the roofline or the rear backlight, by attempting to pass a 25 ± 0.5 mm sphere between them. In the case of convertibles, the diameter of the sphere is 50 ± 0.5 mm.
- 2.3.2.2. Adjust the top of the head restraint to the lowest position of adjustment intended for normal use, other than any non-use position described in paragraph 5.4. of this Regulation, and measure the height.

Determination of intersection point IP

Adjust the head restraint to the uppermost position. If the head restraint is tiltable or adjustable fore-and-aft, the tilt and fore-and-aft adjustment used for the determination of CP will be kept.

The IP is determined on the front surface of the head restraint as the intersection with a vertical line rearwards of CP (see Figure 1-2) at the "distance x" (as given in table 1).

Where the IP would be located rearwards of the horizontal top of the head restraint, the IP will be designated at the horizontal top of the head restraint (see Figure 1-4).

Note: consider all references to "horizontal top" for similar solution.

Where the CP is designated at the horizontal top of the head restraint in paragraph 2.3.1. of this Annex, and there is no existing point of the IP on the head restraint surface, the IP shall be designated on the horizontal top of the head restraint as determined in accordance with paragraph 2.3.1. of this Annex.

The determined "IP" will be kept in any adjustment position.

For head restraints not adjustable for height, the IP is to be determined in the fixed position.

Table 1*Head position table*

Location of the back-of-head of two designated males in automotive posture with respect to the R-point at several design torso angles, and their in-between "distance x"

Design torso angle	X-coordinate of back-of-head calculated for the mid-sized male	Z-coordinate of back-of-head calculated for the mid-sized male	X-coordinate of back-of-head calculated for large male ²	"Distance x": distance between X-coordinates of back-of-head of both males
	$504.5 * \sin(\text{design torso angle} - 2.6) + 71$	$504.5 * \cos(\text{design torso angle} - 2.6) + 203$	$593 * \sin(\text{design torso angle} - 2.6) + 76$	$88.5 * \sin(\text{design torso angle} - 2.6) + 5$
5	92	707	101	9
6	101	707	111	10
7	110	706	121	12
8	118	705	132	13
9	127	704	142	15
10	136	703	152	16
11	145	702	163	18
12	153	701	173	19
13	162	699	183	21
14	171	698	193	22
15	179	696	203	24
16	188	694	213	26
17	196	692	223	27
18	205	689	233	29
19	213	687	243	30
20	222	684	253	31
21	230	682	263	33
22	239	679	273	34
23	247	676	283	36
24	255	673	292	37
25	263	669	302	39
26	271	666	312	40
27	279	662	321	42
28	287	659	330	43
29	295	655	340	44
30	303	651	349	46

² The large male is represented by a virtually up-scaled Torso and Neck Link; where the mid-sized male version of the Torso and Neck Link measures 504.5 mm and 203 mm with the head room probe 71 mm rearwards, the up-scaled version for the large male measures respectively 593 mm and 219 mm with the head room probe 76 mm rearwards.

2.3.3. Determination of the highest head restraint height

The head restraint height is the distance from the R-point, parallel to the torso reference line and limited by a line perpendicular to the torso reference line intersecting IP (see Figure 1-3).

After the coordinates of the IP are determined, the highest head restraint height can be calculated by its longitudinal (ΔX) and vertical (ΔZ) distance from the R-point (see Figure 1-3), as follows:

Head restraint height =

$\Delta X \cdot \text{SIN}(\text{design torso angle}) + \Delta Z \cdot \text{COS}(\text{design torso angle})$

2.3.3.1. Determination of the highest head restraint height in case of exception according to paragraphs 5.1.1.4. and 5.1.1.6. of this Regulation.

Adjust the head restraint to its highest position intended for occupant use and measure the clearance between the highest point on the centre line of the head restraint and the interior surface of the roofline or the rear backlight, by attempting to pass a 50 ± 0.5 mm sphere, between them.

2.3.4. Determination of the lowest head restraint height

Adjust the head restraint to the lowest position of adjustment intended for normal use other than any non-use position described in paragraph 5.4. of this Regulation.

In this lowest in-use position, the head restraint height is the distance from the R-point, parallel to the torso reference line and limited by a line perpendicular to the torso reference line intersecting the point IP (the IP was determined for the highest head restraint height in paragraph 2.3.3. of this Annex).

Figure 1-1
Goniometry in the test procedure using apparatus that facilitate the measurement of coordinates.

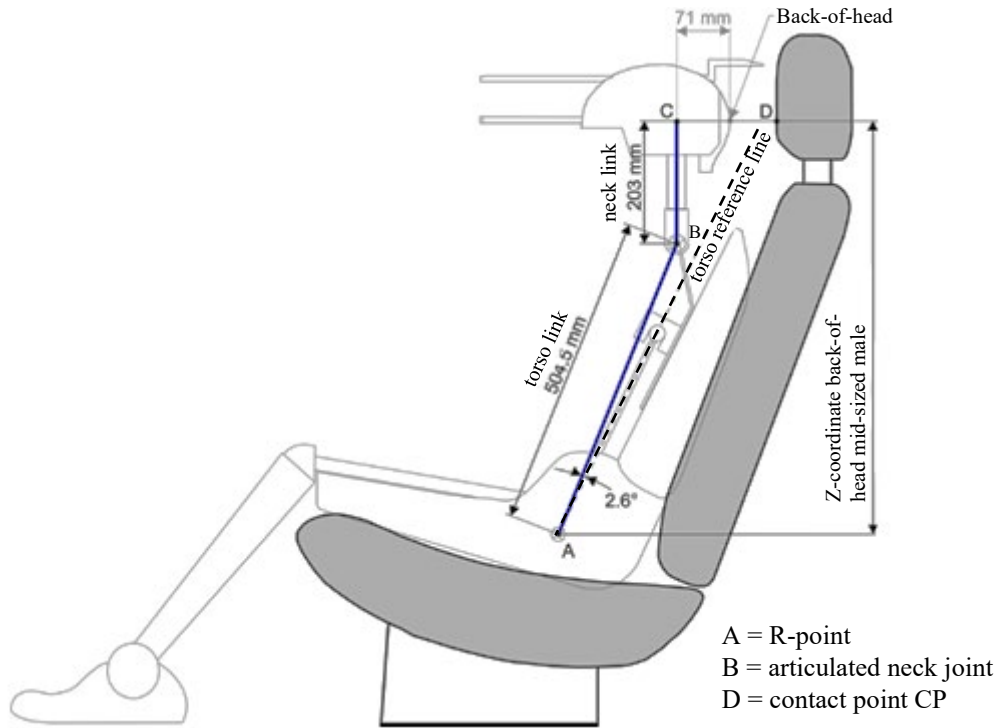

The H-point machine is shown to explain the concept but is not needed for this test procedure.

Figure 1-2

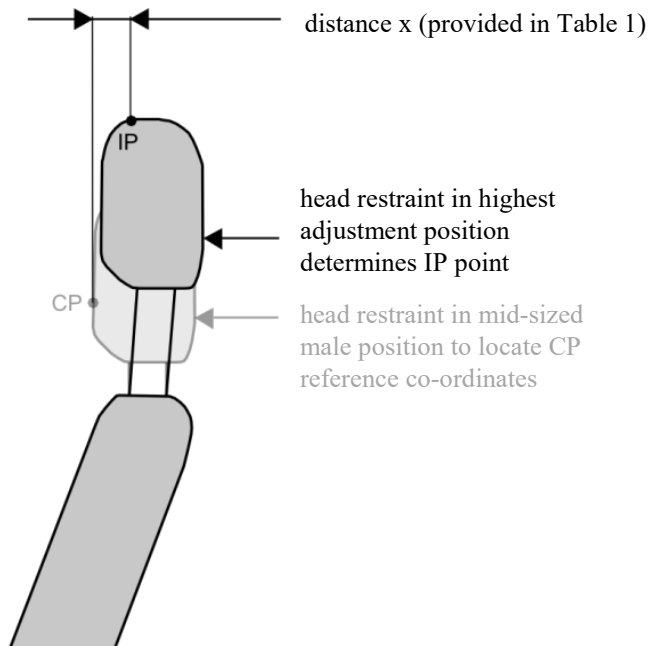

Figure 1-3

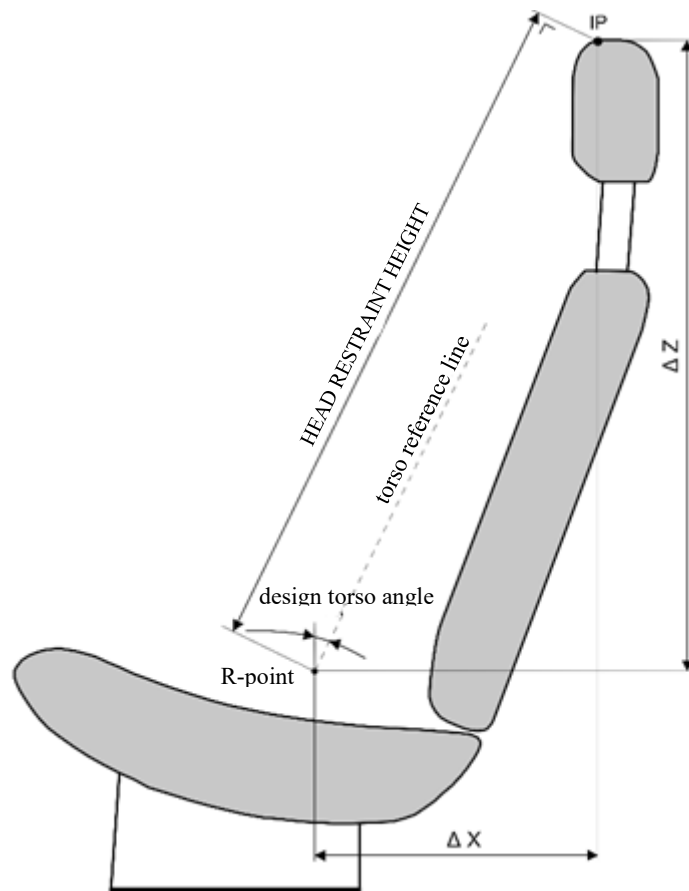

Figure 1-4

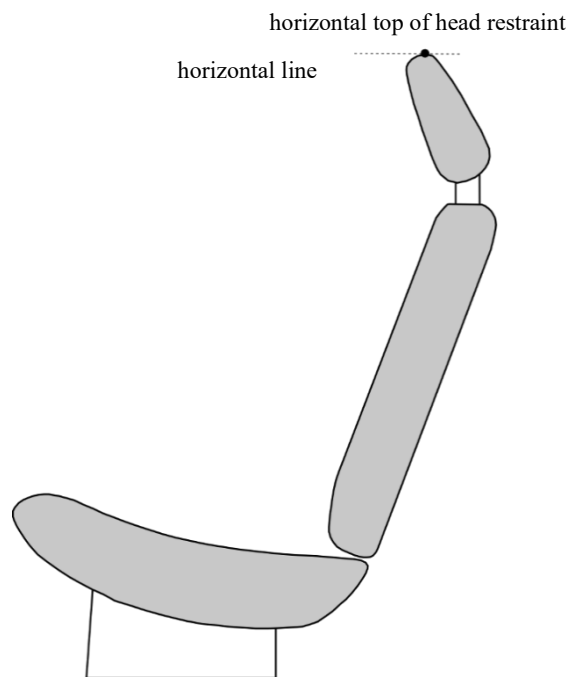
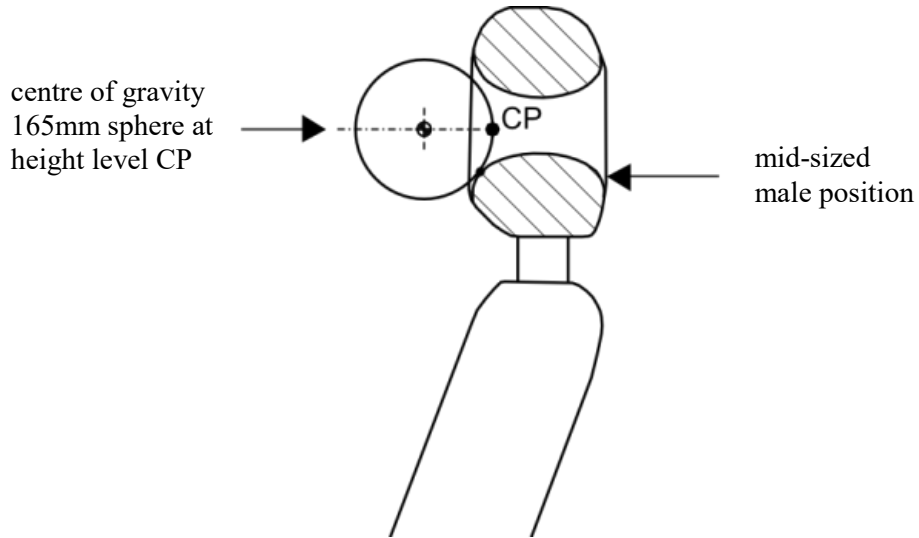

Figure 1-5



- 2.4. Height measurement for front centre and rear outboard head restraints
- 2.4.1. If adjustable, adjust the top of the head restraint to the lowest position of adjustment intended for normal use, other than any non-use position described in paragraph 5.4. of this Regulation and measure the height.
- 2.4.2. For head restraints that are prevented by the interior surface of the vehicle roofline or rear backlight from meeting the required height as specified in paragraphs 5.1.1.3. or 5.1.1.5. of this Regulation, the requirements of paragraphs 5.1.1.4. and 5.1.1.6. are assessed by the following procedure:
 - 2.4.2.1. If adjustable, adjust the head restraint to its maximum height and measure the clearance between the top of the head restraint or the seat back at all seat back angles for intended use and the interior surface of the roofline or the rear backlight, by attempting to pass a 25 ± 0.5 mm sphere between them. In the case of convertibles, the diameter of the sphere is 50 ± 0.5 mm.

Annex 2

Minimum width measurement test procedure

1. Purpose

The purpose of this test procedure is to demonstrate compliance with the minimum width requirements described in paragraph 5.1.2. of this Regulation.
2. Procedure for width measurement
 - 2.1. The seat is adjusted such that its H-point coincides with the R-point; if the seat back is adjustable, it is set at the design seat back angle; both these adjustments are in accordance with the requirements of paragraph 2.1. of Annex 1.

~~The head restraint shall be adjusted to its highest and most rearward position relative to the seat back.~~
 - 2.2. The plane S1 is a plane perpendicular to the reference line and situated 65 ± 3 mm below the **effective** top of the head restraint.
 - 2.3. Planes P and P' are vertical longitudinal planes, tangential to each side of the head restraint to be measured.
 - 2.4. Measure the distance L and L', measured in the plane S1 between the vertical longitudinal plane passing through the torso line and vertical longitudinal planes P and P'.

Figure 2-1

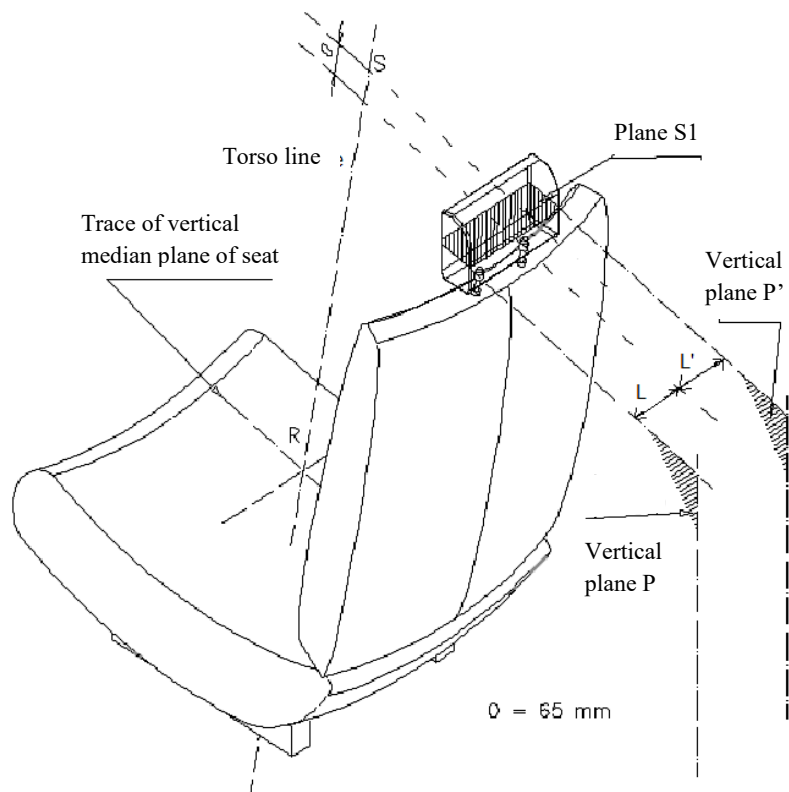

Annex 3

Gap measurement test procedure

1. Purpose

The purpose of this test procedure is to evaluate any gaps within head restraints as well as gaps between the bottom of the head restraint and the top of the seat back, in accordance with the requirements of paragraphs 5.1.3. and 5.1.4. of this Regulation.

Any gaps within the head restraint are measured using the sphere procedure described in paragraph 2. of this Annex.

Gaps between the bottom of the head restraint and the top of the seat back are measured using either the sphere procedure described in paragraphs 2.1. to 2.5. of this Annex, or, at the manufacturer option, using the linear procedure described in paragraph 3. of this Annex.
2. Gap measurement using a sphere
 - 2.1. The seat is adjusted such that its H-point coincides with the R-point; if the seat back is adjustable, it is set at the design seat back angle; both these adjustments are in accordance with the requirements of paragraph 2.1. of Annex 1.
 - 2.1.1 The head restraint shall be adjusted to its highest and most rearward position relative to the seat back.**
 - 2.2. The head restraint is adjusted to its lowest height position and any backset position intended for occupant use.
 - 2.3. The area of measurement is anywhere between two vertical longitudinal planes passing at 85 mm on either side of the torso line and above the top of the seat back.
 - 2.4. Applying a load of no more than 5 N against the area of measurement specified in paragraph 2.3. above, place a 165 ± 2 mm diameter spherical head form against any gap such that at least two points of contact are made within the area.
 - 2.5. Determine the gap dimension by measuring the straight line distance between the inner edges of the two furthest contact points, as shown in Figures 3-1 and 3-2.
 - 2.6. For gaps within the head restraint, if the measurement determined in paragraph 2.5. of this Annex exceeds 60 mm, then in order to demonstrate compliance with the requirements of paragraph 5.1.3. of this Regulation, the seat back displacement test procedure described in Annex 65 is performed, by applying to each gap, using a sphere of 165 mm in diameter, a force passing through the centre of gravity of the smallest of the sections of the gap, along transversal planes parallel to the torso line, and reproducing a moment of 373 Nm about the R point.

Figure 3-1
Measurement of a vertical gap "A".

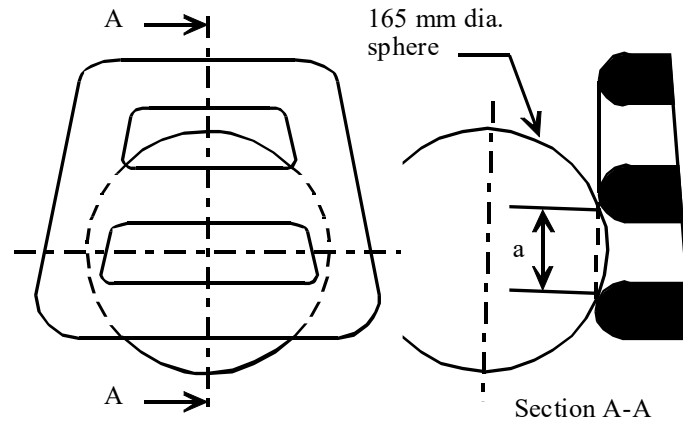

Note: Section A-A is to be made in a point of the gap area which allows the maximum sphere intrusion, without exerting any load.

Figure 3-2
Measurement of a horizontal gap "A".

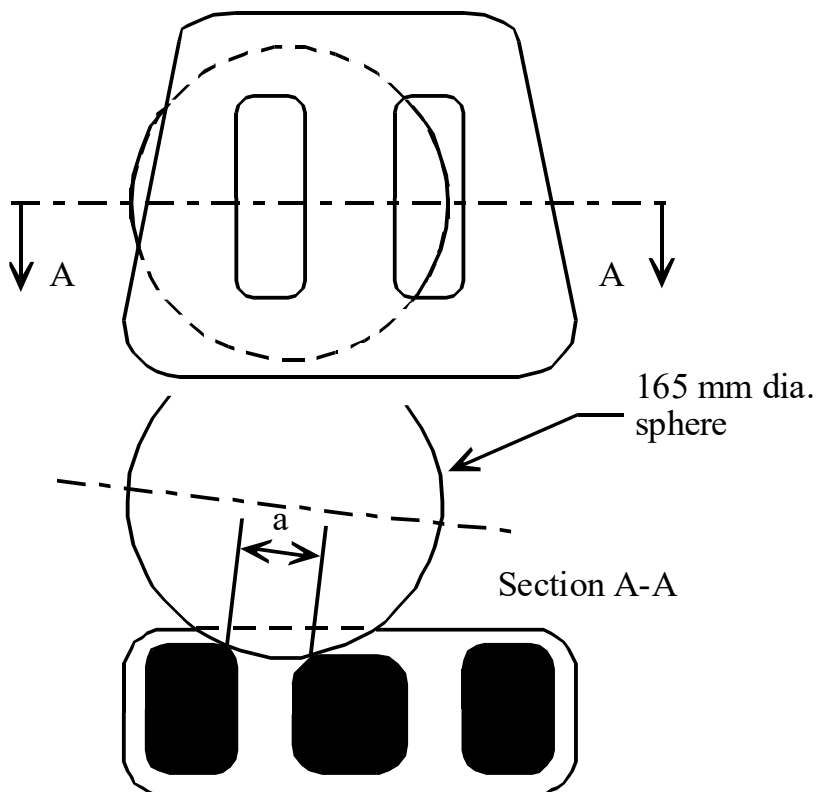

Note: Section A-A is to be made in a point of the gap area which allows the maximum sphere intrusion, without exerting any load.

3. Linear measurement of gap
 - 3.1. The seat is adjusted such that its H-point coincides with the R-point; if the seat back is adjustable, it is set at the design seat back angle; both these adjustments are in accordance with the requirements of paragraph 2.1. of Annex 1.
 - 3.2. The head restraint is adjusted to its lowest height position and any backset position intended for occupant use.
 - 3.3. The gap between the bottom of the head restraint and the top of the seat is measured as the perpendicular distance between two parallel planes, described as follows (see Figure 3-3).
 - 3.3.1. Each plane is perpendicular to the design torso line.
 - 3.3.2. One of the planes is tangent to the bottom of the head restraint.
 - 3.3.3. The other plane is tangent to the top of the seat back.

Figure 3-3

Measurement gap between head restraint and top of the seat back.

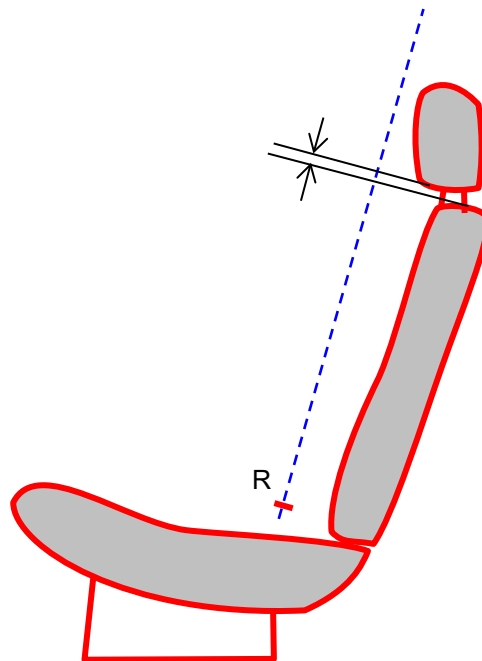

Annex 4Backset measurement test procedure using the HRMD method

1. ~~———— Purpose~~
~~———— Demonstrate compliance with paragraph 5.1.5.2. by measuring the backset using the H point as the reference point.~~
2. ~~———— Procedure for backset measurement using H point as the reference point~~
~~———— Demonstrate compliance with paragraph 5.1.5.2. by measuring the backset of the head restraint using the three dimensional H point machine, defined in Annex 13, and the HRMD (Figure 4 1). This procedure uses the H point as the reference point.~~
 - 2.1. ~~———— The test vehicle is levelled using the door sill (front to rear level) and centre luggage compartment (side to side level) as reference points.~~
 - 2.2. ~~———— The test vehicle is preconditioned at a temperature of $20^{\circ}\text{C} \pm 10^{\circ}\text{C}$ to ensure that the seat material reaches room temperature.~~
 - 2.3. ~~———— Remove the head room probe from the three dimensional H point machine and install the two washers (supplied with the HRMD) in the spaces remaining on the H point pivot.~~
 - 2.4. ~~———— Set up the seat as described in Annex 12, paragraph 3.3. If the seat back is adjustable, it is set at an initial inclination position closest to design angle as measured by the three dimensional H point machine. If there is more than one inclination position closest to design angle, set the seat back inclination to the position closest to and rearward of the design angle.~~
 - 2.5. ~~———— Set up the H point machine as described in Annex 12, paragraphs 3.4. through 3.10.~~
 - 2.6. ~~———— Confirm the H point assembly is level, facing directly forward and located in the centreline of the vehicle seat. As necessary reposition the seat pan.~~
 - 2.7. ~~———— Install the right and left buttock weights. Install four of the torso weights used in Annex 12, paragraph 3.11., and the two larger HRMD chest weights; alternating left to right. The HRMD torso weights are installed last and with the flat side down. Maintain H point machine level.~~
 - 2.8. ~~———— Confirm the actual torso angle is $\pm 1.0^{\circ}$ of the design torso angle by placing an inclinometer on the lower brace of the torso weight hangers. If the measured angle is outside this range, if possible adjust the seat back angle to be $\pm 1.0^{\circ}$ of the design seat back angle. If an adjustment is made, remove the buttock and torso weights and repeat the steps contained in paragraphs 3.9. through 3.10. of Annex 12, along with steps as described in paragraphs 2.6. and 2.7. of this Annex until the actual torso angle is $\pm 1.0^{\circ}$ of the design seat back angle.~~
 - 2.9. ~~———— Perform the steps contained in paragraph 3.12. of Annex 12.~~
 - 2.10. ~~———— Attach the HRMD to the three dimensional H-point machine.~~
 - 2.11. ~~———— Confirm the actual torso angle remained $\pm 1.0^{\circ}$ of the design seat back angle by placing an inclinometer on the lower brace of the torso weight hangers. If the actual torso angle is outside this range, if possible carefully adjust the seat back~~

angle to be $\pm 1.0^\circ$ of the design seat back angle. If the legs and seat pan of the three dimensional H point machine move during this procedure, remove the HRMD, the buttock and torso weights, and repeat the steps contained in paragraphs 3.9. through 3.11. of Annex 12, along with steps as described in paragraphs 2.6. through 2.10. of this Annex until the actual torso angle is $\pm 1.0^\circ$ of the design seat back angle.

- 2.12. Level the HRMD and extend the sliding scale on the back of the head until it contacts the head restraint. Confirm that the scale is positioned laterally within 15 mm of the torso line and take the backset measurement.

Figure 4-1

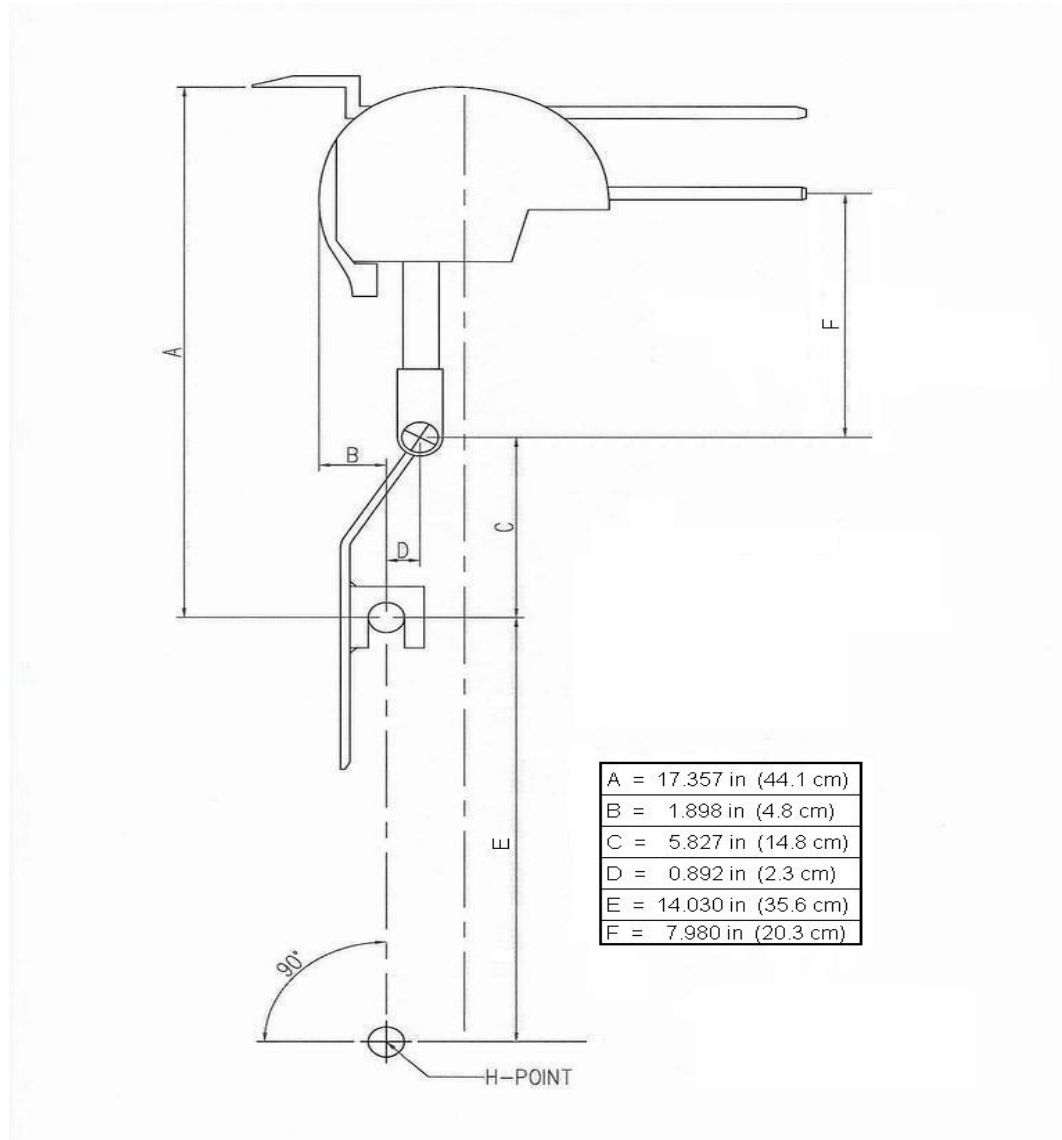

}

Annex 54

Backset measurement test procedure using the R-point method

1. Purpose

Demonstrate compliance with paragraph 5.1.5.2. of this Regulation by measuring the backset using the R-point as the reference point.
2. Procedure for backset measurement using R-point as the reference point

Demonstrate compliance with paragraph 5.1.5.2. of this Regulation by measuring the **R-point** backset of the head restraint **based on the usage of apparatus that facilitates the measurement of coordinates** and using the dimensions as illustrated in Figure 1.1 of Annex 1. ~~using the backset measurement apparatus defined in paragraph 2.1. of this Annex and the following procedures:~~

 - ~~2.1. Backset measuring apparatus~~

~~The backset measurement apparatus consists of (see Figure 5-2):~~

 - ~~2.1.1. A straight edge (lower arm) AB. The lower point A is placed at the R point location. Point B is located at a distance of 504.5 mm from the R point. The line AB is 2.6 degrees forward of the design torso angle.~~
 - ~~2.1.2. A vertical straight edge (upper arm) BC. Point C is located at a distance of 203 mm vertically up from point B.~~
 - ~~2.2.~~ **2.1.** Adjust the seat such that its H-point coincides with the R-point, in accordance with the following requirements.
 - ~~2.2.1.~~ **2.1.1.** Relationship between the H-point and the R-point

When the seat is positioned in accordance to the manufacturer's specifications, **following the procedure of Annex 11** the H-point, as defined by its co-ordinates, shall lie within a square of 50 mm side length with horizontal and vertical sides whose diagonals intersect at the R-point, and the actual torso angle is within 5 °C of the design torso angle.
 - ~~2.2.2.~~ **2.1.2.** If these conditions are met, the R-point and the design torso angle are used to demonstrate compliance with the provisions of paragraph 5.1.5.2. of this Regulation.
 - ~~2.2.3.~~ **2.1.3.** If the H-point or the actual torso angle ~~does~~ not satisfy the requirements of paragraph ~~2.2.1.~~ **2.1.1.** of this Annex, the H-point and the actual torso angle are determined twice more (three times in all). If the results of two of these three operations satisfy the requirements, the conditions of paragraph ~~2.2.2.~~ **2.1.2.** shall apply.
 - ~~2.2.4.~~ **2.1.4.** If the results of at least two of the three operations described in paragraph ~~2.2.3.~~ **2.1.3.** of this Annex do not satisfy the requirements of paragraph ~~2.2.1.~~ **2.1.1.** of this Annex the centroid of the three measured points or the average of the three measured angles is used and **shall** be regarded as applicable in all cases where the R-point or the design torso angle is referred to in this Annex.
- ~~2.3.~~ **2.2.** Adjust the seat back to its design angle

- 2.4. 2.3. Adjust the front head restraint so that its ~~top point IP~~ **top point IP** is at any height between and inclusive ~~750mm–720mm~~ **720mm and 800mm** ¹ **mm of paragraph 5.1.5.2., measured as described in Annex 1.** If the lowest position of adjustment is above ~~800mm~~ **830** ¹ **mm, adjust the head restraint to that lowest position of adjustment.**
- 2.5. 2.4. In the case of head restraint with adjustable backset, adjust the head restraint at the most rearward position, such that the backset is in the maximum position.
- 2.6. 2.5. Establish point D on the head restraint, point D being the intersection of a line drawn from point C horizontally in the x-direction, with the front surface of the head restraint, **see Figure 1-1 of Annex 1.**
- 2.7. 2.6. ~~Measure the distance CD. The backset is the measured distance CD minus 71 mm~~
Measure the X-coordinate of point D. The R-point backset is the difference between the X-coordinate of point D and the X-coordinate of the back-of-head of the mid-size male as given in Table 1 of Annex 1.

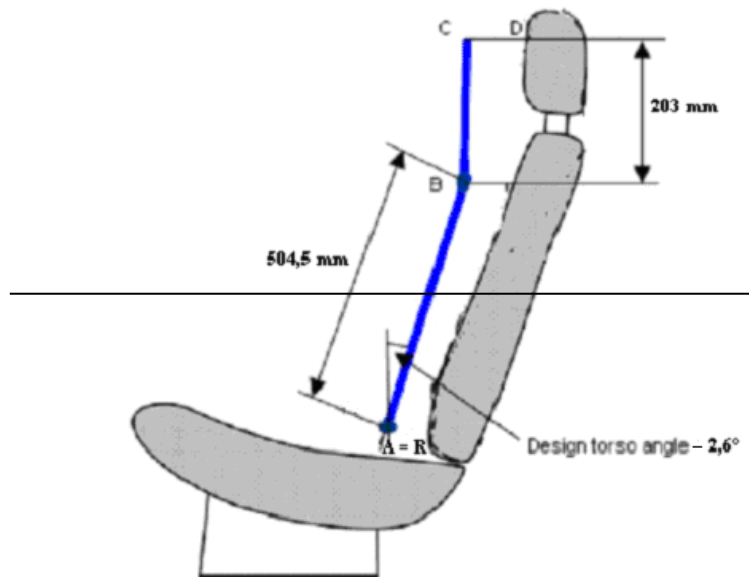

Figure 5-2

¹ A contracting party may opt for a lower value in its domestic legislation if it decides that such value is appropriate.

Annex 65

Displacement, backset retention, and strength test procedure

1. Purpose

To demonstrate compliance with the displacement requirements of paragraph 5.1.3. of this Regulation with paragraph 2. of this Annex.

Demonstrate compliance with the displacement requirements of paragraph 5.2.3.3. of this Regulation with paragraph 2. of this Annex.

Demonstrate compliance with the displacement and backset retention requirements of paragraph 5.2.3.2. of this Regulation with paragraph 3. of this Annex.

Demonstrate compliance with the strength requirements of paragraph 5.2.4. of this Regulation with paragraph 4. of this Annex.
2. Procedure for displacement

The load vectors that generate a moment on the head restraint are initially contained in a vertical plane parallel to the vertical longitudinal zero plane.

 - 2.1. Seat set-up

If the seat back is adjustable, it is adjusted to a position specified by the vehicle manufacturer. If there is more than one inclination position closest to the position specified by the manufacturer, set the seat back inclination to the position closest to and rearward of the manufacturer specified position. If the head restraint position is independent of the seat back inclination position, compliance is determined at a seat back inclination position specified by the manufacturer. Adjust the head restraint to the highest position of vertical adjustment intended for occupant use. Adjust the head restraint to the rearmost (relative to the seat) position of horizontal adjustment backset position.
 - 2.2. In the seat, place a test device having, when viewed laterally, the back pan dimensions and torso line (vertical centre line) of the three dimensional H-point machine, as specified in Annex 12, with the head room probe in the full back position.
 - 2.3. Establish the displaced torso line by creating a rearward moment of 373 ± 7.5 Nm about the R-point by applying a force to the seat back through the back pan at the rate of ~~2.5 Nm/second to 37.3~~ **3.7 Nm/second.** The initial location on the back pan of the moment generating force vector has a height of $290 \text{ mm} \pm 13 \text{ mm}$. Apply the force vector normal to the torso line and maintain it within 2° of a vertical plane parallel to the vehicle vertical longitudinal zero plane. Constrain the back pan to rotate about the R-point. Rotate the force vector direction with the back pan. **In the case of simultaneous testing of bench seats, the rearward moment shall be applied to all seating positions of the bench simultaneously, irrespective of this position being equipped with or without head restraint.**
 - 2.4. Maintain the position of the back pan as established in paragraph 2.3. of this Annex. Using a $165 \pm 2 \text{ mm}$ diameter spherical head form, establish the head form

initial reference position by applying, perpendicular to the displaced torso line, a rearward initial load at the seat centreline at a height 65 ± 3 mm below the **effective** top of the head restraint that will produce a 373 Nm moment about the R-point. After maintaining this moment for 5 seconds, measure the rearward displacement of the head form during the application of the load. **In the case of simultaneous testing of bench seats, the force shall be applied to all head restraints as present on the bench seats simultaneously.***

- 2.5. When determining the rearward displacement for head restraints at a gap greater than 60 mm in accordance with paragraph 5.1.3. of this Regulation, the load of paragraph 2.4. of this Annex is applied through the centre of gravity of the smallest of the sections of the gap, along transversal planes parallel to the torso line.
- 2.6. If the presence of gaps prevents the application of the force, as described in paragraph 2.4. of this Annex at 65 ± 3 mm from the **effective** top of the head restraint, the distance may be reduced so that the axis of the force passes through the centre line of the frame element nearest to the gap.
3. Procedures for backset retention and displacement
 - 3.1. If the seat back is adjustable, it is adjusted to a position specified by the vehicle manufacturer. If there is more than one inclination position closest to the position specified by the manufacturer, set the seat back inclination to the position closest to and rearward of the manufacturer specified position. If the head restraint position is independent of the seat back inclination position, compliance is determined at a seat back inclination position specified by the manufacturer. Adjust the head restraint to the highest position of vertical adjustment intended for occupant use.
 - 3.2. Adjust the head restraint to any backset position.
 - 3.3. In the seat, place a test device having the back pan dimensions and torso line (vertical centre line), when viewed laterally, with the head room probe in the full back position, of the three-dimensional H-point machine.
 - 3.4. Establish the displaced torso line by creating a rearward moment of 373 ± 7.5 Nm about the R-point by applying a force to the seat back through the back pan at the rate between ~~2.5 Nm/second and 37.3~~ **3.7 Nm/second**. The initial location on the back pan of the moment generating force vector has a height of $290 \text{ mm} \pm 13 \text{ mm}$. Apply the force vector normal to the torso line and maintain it within 2° of a vertical plane parallel to the vehicle vertical longitudinal zero plane. Constrain the back pan to rotate about the R-point. Rotate the force vector direction with the back pan.
 - 3.5. Maintain the position of the back pan as established in paragraph 3.4. of this Annex. Using a 165 ± 2 mm diameter spherical head form, establish the head form initial reference position by applying, perpendicular to the displaced torso line, a rearward initial load at the seat centreline at a height 65 ± 3 mm below the **effective** top of the head restraint that will produce a 37 Nm moment about the R-point. Measure the rearward displacement of the head form during the application of the load.
 - 3.6. If the presence of gaps prevents the application of the forces, as described in paragraph 3.5. of this Annex at 65 ± 3 mm from the **effective** top of the head

* Note by the secretariat: text to be better clarified

restraint, the distance may be reduced so that the axis of the force passes through the centre line of the frame element nearest to the gap.

- 3.7. Increase the initial load at the rate of ~~2.5 Nm/second to 37.3~~ **3.7 Nm/second** until a 373 Nm moment about the R-point is produced. Maintain the load level producing that moment for not less than 5 seconds and then measure the rearward displacement of the head form relative to the displaced torso line.
- 3.8. Reduce the load at the rate of ~~2.5 Nm/second to 37.3~~ **3.7 Nm/second** until 0 Nm. Wait ~~10~~ **not more than 2** minutes. Re-load to 37 Nm about the R-point. While maintaining the load level producing that moment, measure the rearward displacement of the head form position with respect to its initial reference position.
4. Strength

Increase the load specified in paragraph 2.6. or paragraph 3.8. of this Annex at the rate between 5 N/second and 200 N/second-to at least 890 N and maintain the applied load for not less than 5 seconds.

Figure 6-1 5-1

r: reference line
r1: displaced reference line

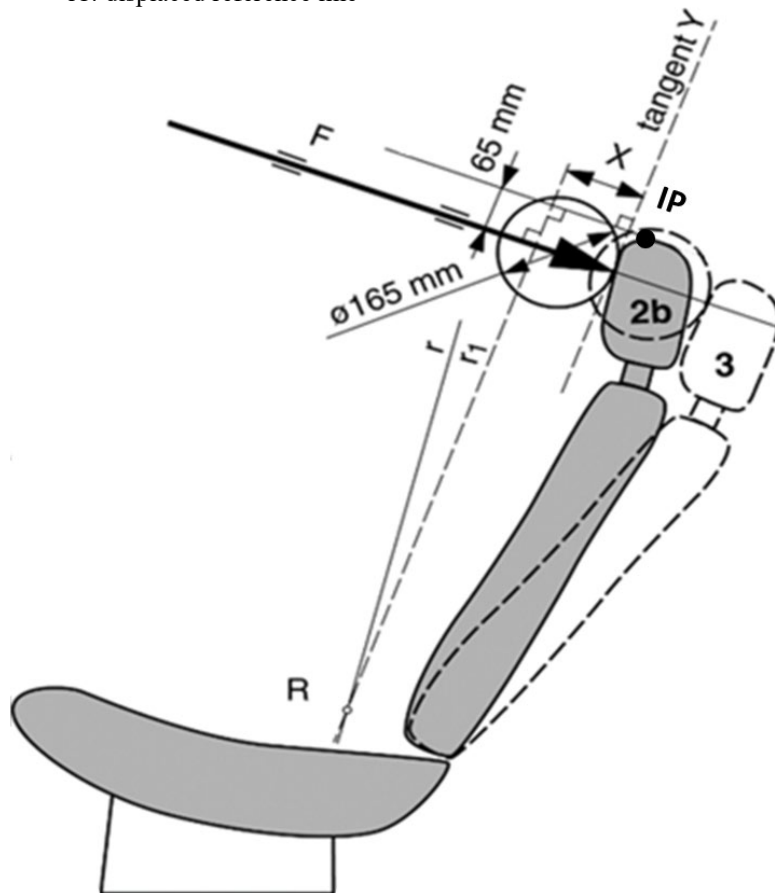

Annex 7 6

Energy absorption test procedure

1. Purpose
Evaluate the energy absorption ability of the head restraint by demonstrating compliance with paragraph 5.2.1. of this Regulation in accordance with this Annex.
2. Seat set-up
The seat is either mounted in the vehicle or firmly secured to the test bench, as mounted in the vehicle with the attachment parts provided by the manufacturer, so as to remain stationary when the impact is applied. The seat-back, if adjustable, is locked in the design position specified by the vehicle manufacturer. If the seat is fitted with a head restraint, the head restraint is mounted on the seat-back as in the vehicle. Where the head restraint is separate, it is secured to the part of the vehicle structure to which it is normally attached.
3. Procedures for energy absorption
The adjustable head restraints are measured in any height and backset position of adjustment.
 - 3.1. Test equipment
 - 3.1.1. Use an impactor with a hemispherical head form of a 165 ± 2 mm diameter. The head form and associated base have a combined mass such that at a speed of **not more than** 24.1 km/h at the time of impact an energy of 152 Joule will be reached.
 - 3.1.2. Instrument the impactor with an acceleration sensing device whose output is recorded in a data channel that conforms to the requirements for a 600 Hz channel class filter as specified in ISO Standard 6487 (2002). The axis of the acceleration-sensing device coincides with the geometric centre of the head form and the direction of impact. As an alternative the impactor can be equipped with 2 accelerometers sensing in the direction of impact and placed symmetrically in comparison to the geometric centre of the spherical head form. In this case the deceleration rate is taken as the simultaneous average of the readings on the two accelerometers.
 - 3.2. Accuracy of the test equipment
The recording instrument used is such that measurements can be made with the following degrees of accuracy:
 - 3.2.1. Acceleration:
Accuracy: ~~± 5~~ **± 5** per cent of the actual value;
Cross-axis sensitivity = < 5 per cent of the lowest point on the scale.
 - 3.2.2. Speed:
Accuracy: ~~± 2.5~~ **± 2.5** per cent of the actual value;
Sensitivity: = < 0.5 km/h.
 - 3.2.3. Time recording:

The instrumentation shall enable the action to be recorded throughout its duration and readings to be made to within one one-thousandth of a second; the beginning of the impact at the moment of first contact between the head form and the item being tested is detected on the recordings used for analysing the test.

- 3.3. Test procedure
- 3.3.1. Propel the impactor toward the head restraint. At the time of impact, the longitudinal axis of the impactor is within $\pm 2^\circ$ of being horizontal and parallel to the vehicle longitudinal axis and the impactor speed is not more than 24.1 km/h.
- 3.3.2. Impact the front surface of the head restraint at any point with a height greater than 635 mm from the R-point and within a **lateral** distance of the head restraint vertical centre line of 70 mm and measure the acceleration.

Annex 87

Height retention test procedure

1. Purpose

Demonstrate compliance with the height retention requirements of paragraph 5.2.2. of this Regulation in accordance with this Annex.
2. Procedures for height retention
 - 2.1. Seat set-up

Adjust the adjustable head restraint so that its **effective** top is at any of the following height positions at any backset position:

 - 2.1.1. For front outboard designated seating positions:
 - 2.1.1.1. The highest position; and
 - 2.1.1.2. Not less than, but closest to ~~800mm~~ **830¹ mm**.
 - 2.1.2. For rear outboard and front centre designated seating positions
 - 2.1.2.1. The highest position; and
 - 2.1.2.2. Not less than, but closest to ~~750mm~~ **720 mm**.
 - 2.1.3. For rear centre designated seating position
 - 2.1.3.1. The highest position; and
 - 2.1.3.2. Not less than, but closest to 700 mm.
 - 2.2. Orient a cylindrical test device having a 165 ± 2 mm diameter in plane view (perpendicular to the axis of revolution), and a 152 mm length in profile (through the axis of revolution), such that the axis of the revolution is horizontal and in the longitudinal vertical plane through the vertical longitudinal zero plane of the head restraint. Position the midpoint of the bottom surface of the cylinder in contact with the head restraint.
 - 2.3. Establish **an** initial reference position by applying a vertical downward load of 50 ± 1 N at a rate of 250 ± 50 N/minute. Determine the reference position after 5 seconds at this load. Mark an initial reference position for the head restraint.
 - 2.4. Measure the vertical distance between the lowest point on the underside of the head restraint and the top of the seat back. (see paragraph 2.9. of this Annex)
 - 2.5. Increase the load at the rate of 250 ± 50 N/minute to at least 500 N and maintain this load for not less than 5 seconds.
 - 2.6. Reduce the load at a rate of 250 ± 50 N/m until the load is completely removed. Maintain this condition for no more than two minutes. Increase the load at a rate of 250 ± 50 N/minute to 50 ± 1 N and, after 5 seconds at this load, determine the position of the cylindrical device with respect to its initial reference position.

¹ A contracting party may opt for a lower value in its domestic legislation if it decides that such value is appropriate.

-
- 2.7. Repeat the measurement of the vertical distance measured between the lowest point on the underside of the head restraint and the top of the seat back. (see paragraph 2.9. of this Annex)
- 2.8. Compare the measurements from paragraphs 2.4. and 2.7. of this Annex. The difference is the measurement required to comply with paragraph 5.2.2. of this Regulation.
- 2.9. If the design of the head restraint is such that it is not possible to measure to the top of the seat then the vertical measurement is taken by marking a horizontal line across the front of the seat back at least 25 mm below the lowest point of the head restraint and the measurement is taken from this line to the underside of the head restraint.
- ~~2.10. Alternatively, when the manufacturer demonstrates that the difference of the reference positions of the cylinder measured in 2.3 and 2.6 of this Annex is smaller than the value required by 5.2.2. of the Regulation, then the test result will also comply to paragraph 5.2.2. of the Regulation. In this case measurements of 2.4. and 2.7. do not need to be recorded.~~

Annex 9 8

Dynamic performance test procedure

1. Purpose

Demonstrate compliance with paragraph 5.3. in accordance with this Annex, using a 50th percentile male Hybrid III or **BioRID II (United Nations)** test dummy.
2. Test equipment
 - 2.1. An acceleration or deceleration test sled.
 - 2.2. 50th percentile male test dummy
 - 2.2.1. Hybrid III
 - 2.2.1.1. Three accelerometers are in the head cavity to measure orthogonal accelerations at the centre of gravity of the head assembly. The three accelerometers are mounted in an orthogonal array, and the intersection of the planes containing the sensitivity axis of the three sensors will be the origin of the array.
 - ~~2.2.3.~~ 2.2.1.2. Equipment for measuring the head to torso angle.
 - 2.2.2. **BioRID II**
 - 2.2.2.1. **Conforming to Addendum 1 to the Mutual Resolution No. 1 (ECE/TRANS/WP.29/1101/Add.1)**
 - ~~2.2.4.~~ 2.2.2.2. Equipment for measuring and recording sled accelerations.
3. Procedures for test set-up
 - 3.1. **Full Vehicle or Body in White (Hybrid III)**
 - ~~3.1.~~ 3.1.1. Mount the vehicle on a dynamic test platform so that the vertical longitudinal zero plane of the vehicle is parallel to the direction of the test platform travel and so that movement between the base of the vehicle and the test platform is prevented. Instrument the platform with an accelerometer and data processing system. Position the accelerometer sensitive axis parallel to the direction of test platform travel.
 - ~~3.2~~ 3.1.2. Remove the tyres, wheels, fluids, and all unsecured components. Rigidly secure the engine, transmission, axles, exhaust system, vehicle frame and any other vehicle component necessary to assure that all points on the acceleration vs. time plot measured by an accelerometer on the dynamic test platform fall within the corridor described in Figure ~~9-1~~ 8-2 and Table ~~9-1~~ 8-1.
 - ~~3.3.~~ 3.1.3. Place any moveable windows in the fully open position.
 - ~~3.4.~~ 3.1.4. Seat Adjustment
 - ~~3.4.1~~ 3.1.4.1. At each designated seating position, if the seat back is adjustable, it is set at an initial inclination position closest to 25° from the vertical, as measured by the three-dimensional H-point machine, as specified in Annex ~~4-12~~ 12. If there is more than one inclination position closest to 25°

from the vertical, set the seat back inclination to the position closest to and rearward of 25°.

~~3.4.2.~~ **3.1.4.2.** Using any control that primarily moves the entire seat vertically, place the seat in the lowest position. Using any control that primarily moves the entire seat in the fore and aft directions, place the seat midway between the **full forward most** and **full rearward rearmost** position. If an adjustment position does not exist midway between the **full forward most** and **full rearward rearmost** positions, the closest adjustment position to the rear of the midpoint is used.

~~3.4.3.~~ **3.1.4.3.** If the seat cushion adjusts independently of the seat back, position the seat cushion such that the highest H-point position is achieved with respect to the seat back, as measured by three-dimensional H-point machine as specified in Annex ~~13~~**12**. If the specified position of the H-point can be achieved with a range of seat cushion inclination angles, adjust the seat inclination such that the most forward part of the seat cushion is at its lowest position with respect to the most rearward part.

~~3.4.4.~~ **3.1.4.4.** If the head restraint is adjustable, adjust the top of the head restraint to a position midway between the lowest position of adjustment and the highest position of adjustment. If an adjustment position midway between the lowest and the highest position does not exist, adjust the head restraint to a position below and nearest to midway between the lowest position of adjustment and the highest position of adjustment.

~~3.4.5.~~ **3.1.4.5.** Adjustable lumbar supports are positioned so that the lumbar support is in its lowest retracted or deflated position.

~~3.5.~~ **3.1.5.** Seat Belt Adjustment

Prior to placing the seat belt around the test dummy, fully extend the webbing from the seat belt retractor(s) and release it three times to remove slack. If an upper adjustable seat belt turning loop (adjustable seat belt D-ring anchorage) exists, place it in the adjustment position closest to the mid-position. If an adjustment position does not exist midway between the highest and lowest position, the closest adjustment position above the midpoint is used.

~~3.6.~~ **3.1.6.** Dress and adjust each test dummy as follows:

Each test dummy is clothed in a form fitting cotton stretch short sleeve shirt with above-the-elbow sleeves and above-the-knee length shorts. The mass of the shirt or shorts shall not exceed 0.06 kg each. Each foot of the test dummy is equipped with a size 11XW shoe whose mass is ~~0.51 ± 0.09 kg~~ **0.57 ± 0.1 kg**. Limb joints are set at 1g, barely restraining the weight of the limb when extended horizontally. Leg joints are adjusted with the torso in the supine position.

~~3.7.~~ **3.1.7.** Hybrid III Test dummy positioning procedure

Place a test dummy at each designated seating position equipped with a head restraint.

~~3.7.1.~~ **3.1.7.1.** Head

The transverse instrumentation platform of the head is level within 1/2 degree. To level the head of the test dummy, the following sequence is followed. First,

adjust the position of the H-point ¹ to level the transverse instrumentation platform of the head of the test dummy. If the transverse instrumentation platform of the head is still not level, then adjust the pelvic angle of the test dummy. If the transverse instrumentation platform of the head is still not level, then adjust the neck bracket of the dummy the minimum amount necessary from the non-adjusted "0" setting to ensure that the transverse instrumentation platform of the head is horizontal within 1/2 degree. The test dummy remains within the limits specified in **footnote 1 of this Annex** after any adjustment of the neck bracket.

~~3.7.2.~~ **3.1.7.2.** Upper arms and hands

Position each test dummy as specified below:

~~3.7.2.1.~~ **3.1.7.2.1.** The driver's upper arms shall be adjacent to the torso with the centre lines as close to a vertical plane as possible.

~~3.7.2.2.~~ **3.1.7.2.2.** The passenger's upper arms are in contact with the seat back and the sides of the torso.

~~3.7.2.3.~~ **3.1.7.2.3.** The palms of the driver's test dummy are in contact with the outer part of the steering wheel rim at the rim's horizontal centre line. The thumbs are over the steering wheel rim and are lightly taped to the steering wheel rim so that if the hand of the test dummy is pushed upward by a force of not less than 0.91 kg and not more than 2.27 kg, the tape shall release the hand from the steering wheel rim.

~~3.7.2.4.~~ **3.1.7.2.4.** The palms of the passenger test dummy are in contact with the outside of the thigh. The little finger is in contact with the seat cushion.

~~3.7.3.~~ **3.1.7.3.** Upper Torso

Position each test dummy such that the upper torso rests against the seat back. The midsagittal plane of the dummy is aligned within 15 mm of the head restraint centreline. If the midsagittal plane of the dummy cannot be aligned within 15 mm of the head restraint centreline then align the midsagittal plane of the dummy as close as possible to the head restraint centreline.

~~3.7.4.~~ **3.1.7.4.** Lower Torso

The H-points of the driver and passenger test dummies shall coincide within 12.5 mm in the vertical dimension and 12.5 mm in the horizontal dimension of a point 6.25 mm below the position of the H-point determined by the manikin defined in Annexes ~~1211~~ and Annex ~~1312~~.

~~3.7.5.~~ **3.1.7.5.** Pelvic Angle

As determined using the pelvic angle gauge which is inserted into the H-point gauging hole of the dummy, the angle measured from the horizontal on the 76 mm flat surface of the gauge is $22.5 \pm 2.5^\circ$.

~~3.7.6.~~ **3.1.7.6.** Legs

Position each test dummy as follows:

¹ The H-points of the driver and passenger test dummies shall coincide within 12.5 mm in the vertical dimension and 12.5 mm in the horizontal dimension of a point 6.25 mm below the position of the H-point determined by using the equipment and procedures specified in except that the length of the lower leg and thigh segments of the H-point machine shall be adjusted to 414 mm and 401 mm, respectively.

The upper legs of the driver and passenger test dummies shall rest against the seat cushion to the extent permitted by placement of the feet. The initial distance between the outboard knee clevis flange surfaces is 269 mm. To the extent practicable, the left leg of the driver dummy and both legs of the passenger dummy are in vertical longitudinal planes. To the extent practicable, the right leg of the driver dummy is in a vertical plane. Final adjustment to accommodate the placement of feet in various passenger compartment configurations is permitted.

~~3.7.7.~~ **3.1.7.7.** Feet

~~3.7.7.1.~~ **3.1.7.7.1.** Driver's position

~~3.7.7.1.1.~~ **3.1.7.7.1.1.** If the vehicle has an adjustable acceleration pedal, adjust it to the full forward position. Rest the right foot of the test dummy on the undepressed accelerator pedal with the rearmost point of the heel on the floor pan in the plane of the pedal. If the foot cannot be placed on the accelerator pedal, set it initially perpendicular to the **lower** leg and then place it as far forward as possible in the direction of the pedal centreline with the rearmost point of the heel resting on the floor pan. If the vehicle has an adjustable accelerator pedal and the right foot is not touching the accelerator pedal when positioned as above, move the pedal rearward until it touches the right foot. If the accelerator pedal still does not touch the foot in the full rearward position, leave the pedal in that position.

~~3.7.7.1.2.~~ **3.1.7.7.1.2.** Place the left foot on the toeboard with the rearmost point of the heel resting on the floor pan as close as possible to the point of intersection of the planes described by the toeboard and the floor pan and not on the wheel well projection. If the foot cannot be positioned on the toeboard, set it initially perpendicular to the lower leg and place it as far forward as possible with the heel resting on the floor pan. If necessary to avoid contact with the vehicle's brake or clutch pedal, rotate the test dummy's left foot about the lower leg. If there is still pedal interference, rotate the left leg outboard about the hip the minimum distance necessary to avoid the pedal interference. For vehicles with a foot rest that does not elevate the left foot above the level of the right foot, place the left foot on the foot rest so that the upper and lower leg centrelines fall in a vertical plane.

~~3.7.7.2.~~ **3.1.7.7.2.** Front Passenger's position

~~3.7.7.2.1.~~ **3.1.7.7.2.1.** Vehicles with a flat floor pan/toeboard

Place the right and left feet on the vehicle's toeboard with the heels resting on the floor pan as close as possible to the intersection point with the toeboard. If the feet cannot be placed flat on the toeboard, set them perpendicular to the lower leg centrelines and place them as far forward as possible with the heels resting on the floor pan.

~~3.7.7.2.2.~~ **3.1.7.7.2.2.** Vehicles with wheelhouse projections in passenger compartment

Place the right and left feet in the well of the floor pan/toeboard and not on the wheelhouse projection. If the feet cannot be placed flat on the toeboard, initially set them perpendicular to the lower leg centrelines and then place them as far forward as possible with the heels resting on the floor pan.

~~3.7.7.3.~~ **3.1.7.7.3.** Rear Passenger's position

Position each test dummy as specified in paragraph 3.1.7.7.2. of this Annex, except that feet of the test dummy are placed flat on the floorpan and beneath

the front seat as far forward as possible without front seat interference. If necessary, the distance between the knees can be changed in order to place the feet beneath the seat.

~~3.8.~~ **3.1.8.** All tests specified by this standard are conducted at an ambient temperature of 18 to 28 °C.

~~3.9.~~ **3.1.9.** All tests are performed with the ignition "on."

3.2. Setup of Seat and Dummy on the Sled (BioRID II).

3.2.1. An acceleration sled with the dummy seated facing the direction of motion shall be used. Sled accelerations shall be measured by an appropriate accelerometer attached to the sled platform

The temperature in the test laboratory shall be $22.5^{\circ} \pm 3^{\circ}\text{C}$ with a relative humidity of between 10 per cent and 70 per cent. The test dummy and seat being tested shall be soaked at this temperature for at least 3 hours prior to the test.

All tests shall be performed with the active elements of the system designed to operate during rear impact set to their operation condition (e.g. Active head restraint, Seat belt pre-tensioner). The time to fire (TTF) required for a specific element of the active head restraint shall be specified by the vehicle manufacturer.

3.2.2. Acceleration Sled

3.2.2.1. The parts of the vehicle structure considered essential for the replication of the vehicle rigidity regarding the seat, its anchorages, the safety-belt anchorages and the head restraints shall be secured to the sled.

It shall be so constructed that no permanent deformation appears after the test. Where the upper anchorage has an adjustable height position, it shall be set nearest to the mid-range position permitted by the design

3.2.2.2. The sled shall be capable of accommodating, in an appropriate manner, such equipment as may be specified by the manufacturer as necessary for the correct functioning of advanced head restraint systems (active head restraints).

3.2.2.3. A toe board comprising a horizontal section and a forward facing section oriented at 45° from the horizontal shall be provided.

3.2.2.4. Some sled motion is allowed at the initiation of the test ($T=0$) however, the dummy's head, T1 vertebra, and the sled should have the same velocity $\pm 0.1\text{m/s}$ at $T=0$. The back of the dummy's head and T1 vertebra should be in the same position ($\pm 5\text{mm}$) relative to the head restraint at $T=0$ as the initial test set-up.

3.2.3. Mounting the seat on the sled.

3.2.3.1. Mount the seat, including all of its adjustment mechanisms and hardware that normally connect it to the vehicle floor on the sled platform so that the seat's orientation relative to the horizontal is the same as it would be in the vehicle. The gap between the front of the seat and rear of the toe board shall be no more than 100 mm. Instrument the platform with an accelerometer mounted such that its sensitive axis is parallel to the direction of test platform travel.

3.2.4. Seat Adjustment

- 3.2.4.1. The seat shall be set as specified by the manufacturer, with regard to both the design position of the seat back (see paragraph 3.4. of this Regulation) and the position of the seat itself. This position shall be the one where the H-point coincides with R₅₀-point.
- In the absence of any specification declared by the manufacturer, the procedures of paragraphs 3.2.4.2. to 3.2.4.5. of this Annex shall apply.
- 3.2.4.2. Where adjustment is not specified, the seat shall be adjusted to its mid-position in both the horizontal and vertical directions.
- If an adjustment position does not exist midway between those positions, place the seat midway between the most forward and most rearward position. The closest adjustment position to the rear of the midpoint shall be used.
- 3.2.4.3. Where a cushion adjustment is not specified, and where the seat cushion is adjustable independently of the seat back, adjust the seat cushion inclination to its mid-position. All other cushion adjustments shall be in a fully retracted position, with the exception of cushion side bolsters which shall be set to their widest position.
- 3.2.4.4. Any adjustable lumbar supports shall be positioned so that the lumbar support is in its lowest retracted or deflated position. Arm rests shall be set in the stowed position.
- 3.2.4.5. Any other seat adjustment device must be set in its most retracted or deflated position.
- 3.2.4.6. Where a design torso angle is not specified and where the seat back is adjustable, it shall be set at a torso angle closest to 25° ±1° from the vertical, as measured using the three-dimensional H-point machine, as specified in Annex 12. If there is more than one inclination position close to a torso angle of 25 ° then it shall be set to the position closest to and rearward of 25 °.
- 3.2.5. Head Restraint Adjustment
- 3.2.5.1. If the head restraint adjusts automatically, the adjustments from paragraphs 3.2.4.1. to 3.2.4.6. of this Annex shall apply.
- 3.2.5.2. Adjust the head restraint to the position intended for use by the 50th percentile male, as specified by the manufacturer. If not available adjust the head restraint in the midway between the lowest and the highest position and follow the paragraph 3.2.5.2.2. of this Annex.
- 3.2.5.2.1. Where the adjustment of the head restraint is not automatic, it shall be set in accordance with the manufacturer's specification.
- 3.2.5.2.2. If a locking position midway between the lowest and the highest position does not exist, adjust the head restraint to the position determined by the paragraphs below.
- If a locking position exists within 10 mm vertically upwards from the geometric mid-position, this shall be the test position. If no locking position exists within 10 mm vertically upwards from the geometric mid-position then the next locking position down shall be the test position. **This shall be determined from the top of the head restraint.**

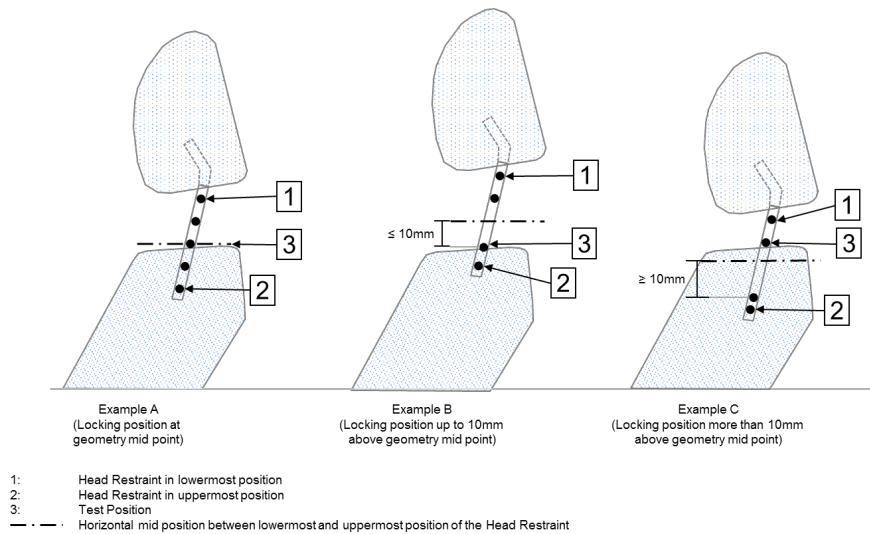

Figure 8-1.

When the head restraint has a locking fore-aft adjustment, it shall be in the midpoint. If a locking position exists within 10 mm horizontally forward from the geometric mid-position, this shall be the test position. If no locking position exists within 10 mm horizontally forwards from the geometric mid-position then the next locking position rearwards shall be the test position, as shown in Figure 8-1.

If no fore-aft locking positions are available for the head restraint it shall be tilted fully rearward.

3.2.6. BioRID II Reference measurement

3.2.6.1. Using the 3D-H measuring machine, check that the H-point coincides with the R₅₀-point, in accordance with the following requirements.

The procedure set out in Annex 11 shall be used to verify the H-point relationship to the R₅₀-point specified by the manufacturer.

The relative positions of the R-point and the H-point relationship shall be considered satisfactory for the seating position in question if the "H-point", lies within a square of 50 mm side length with horizontal and vertical sides F whose diagonals intersect at the R₅₀-point, and the torso angle is within 5° of the design torso angle.

3.2.6.2. Back of the head reference position

The back of the head reference position for the BioRID II is the value determined for the 50th percentile in Table 1, Annex 1 of this Regulation with reference to the specified torso angle minus 15 mm (increasing the backset as shown in figure 8-2).

Where a design torso angle is not specified, set the angle as specified in paragraph 3.2.4.6. of this Annex. Both the measured H-point and angle shall be used when referencing Table 1 of Annex 1.

3.2.7. Dummy Installation

- 3.2.7.1. The dummy's clothing shall comprise two pairs of shorts and two shirts made of a nylon fabric. The fabric has a different texture on the outside as it does on the inside – shiny and matt. The dummy shall be dressed with both sets of clothing so that the shiny sides of the materials come face to face with each other. Shoes are men's dress oxford type, US size 11 (European size 45) extra wide that meet military specifications MIL-S-13192P. Each shoe weighs 0.28 ± 0.1 kg and has an overall length of 320–325mm.
- 3.2.7.2. The seat shall be in an unloaded condition for at least 15 minutes before installing the dummy.
- 3.2.7.3. The appropriate lifting tools and the attachment points recommended by the dummy manufacturer shall be used to position the dummy in the seat. The dummy shall initially be installed with its H-point rearward of the target H-point and the pelvis only moved forward to achieve the position indicated in paragraph 3.2.7.6. below. In the event that the dummy is moved forward of the specified target H-point, the dummy shall be removed from the seat and the complete installation procedure repeated. It is not permissible to push the pelvis rearward to bring the pelvis H-point into line with the specified H-point position.
- 3.2.7.4. Adjust the test dummy's midsagittal plane to be vertical and aligned with the centreline of the seat. The instrumentation platform in the head shall be laterally level within $\pm 0.5^\circ$.
- 3.2.7.5. Adjust the pelvis angle to the actual torso angle recorded by the procedure specified in paragraph 3.14.2. of Annex 11 plus $1.5 \pm 2.5^\circ$.
- 3.2.7.6. The BioRID shall be installed such that its H-point is positioned 20 mm \pm 10 mm forward of the R₅₀-point, as shown in Figure 8-2, while keeping the pelvis angle within the range specified in paragraph 3.2.7.5. above.

Figure 8-12

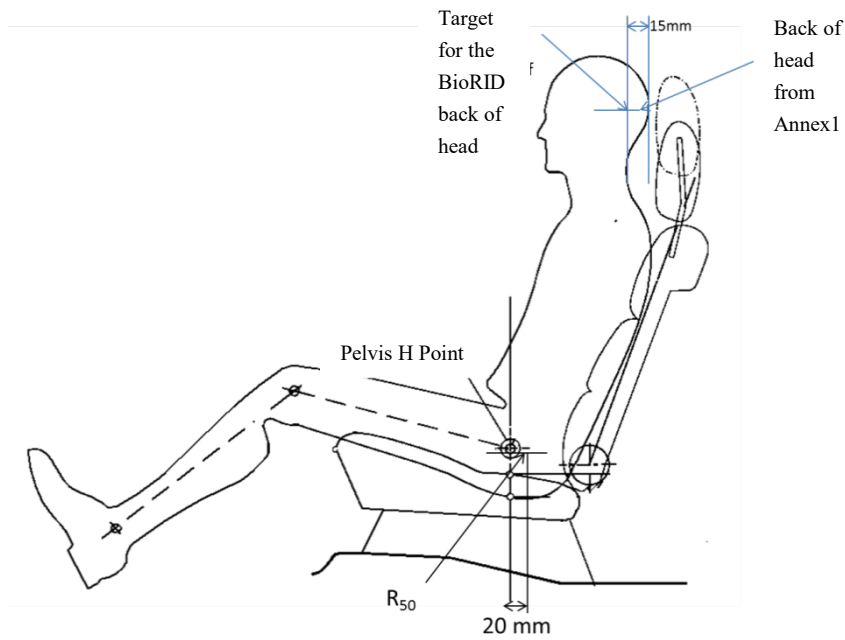

3.2.7.7. Back of head adjustment.

3.2.7.7.1. The back of head (the most rearward position of the head when the head is horizontally level $\pm 1^\circ$) of the BioRID shall be positioned at the reference position described in paragraph 3.2.6.2. of this Annex with a tolerance of ± 5 mm.

3.2.7.7.2. If the test dummy back of head position is found to be different by more than ± 5 mm from that of the BioRID reference back of head, obtained by the procedure specified in paragraph 3.2.6.2. of this Annex, then paragraphs 3.2.7.7.2.1. and 3.2.7.7.2.2. below shall apply.

3.2.7.7.2.1. Tip the head fore/aft no more than $+3.5 / -0.5^\circ$ from level in order to meet the backset requirement.

3.2.7.7.2.2. After carrying out the adjustments specified in paragraph 3.2.7.7.2.1. above and if it is still not possible to set the test dummy backset measurement to within 15 ± 2 mm of the Back of the Head reference position specified in paragraph 3.2.6.2. above then the dummy's pelvis angle and the H-point position shall be adjusted within their respective tolerance bands while prioritising the adjustment of the pelvis angle tolerance to achieve correct backset. It is not permitted to achieve the required position by pushing the dummy rearward.

3.2.7.8. The upper legs of the driver dummy shall rest against the seat cushion to the extent permitted by placement of the feet. Adjust the spacing of the legs so that the centreline of the knees and ankles is 200 mm (± 10 mm) apart and ensure that the knees are level.

3.2.7.8.1. Adjust the dummy's feet and/or the horizontal position of the adjustable toe board so that the heel of its shoe is resting on the heel surface. The tip of the shoe shall rest on the toe pan between 230 mm and 270 mm from the intersection of the heel surface and toe board, as measured along the surface of the toe board. The heel rest position is determined using the

heel rest location defined from the vehicle measurements, or from a specified point from the vehicle manufacturer.

3.2.7.8.2. The test dummy's upper arms shall be positioned so that they are as close to the sides of the dummy as possible, with the rear of the upper arms being in contact with the seatback and the elbows bent such that the small fingers of both hands of the dummy are in contact with the vehicle seat cushion with the palms of the hands facing towards the dummy's thighs.

3.2.8. Seat belt adjustment

3.2.8.1. With the test dummy seated in accordance with the requirements of paragraph 3.2.7. above, place the belt around the test dummy and fasten the latch. Remove all slack from the lap belt. Pull the upper torso webbing out of the retractor and allow it to retract. Repeat this operation four times. Apply a 9 to 18 N tension load to the lap belt. The lap belt routing shall be the resultant of the installation procedure and shall not be artificially altered.

4. Test procedure.

4.1. Full Vehicle or Body in White (Hybrid III).

~~4.1.~~ **4.1.1.** Accelerate or decelerate the dynamic test platform to reach a delta V of 17.3 ± 0.6 km/h. All of the points on the acceleration vs. time curve fall within the corridor described in Figure 9-1 8-3 and Table 9-1 8-1 when filtered to channel class 60, as specified in the SAE Recommended Practice J211/1 (revision March 1995). Measure the maximum rearward angular displacement.

~~4.2.~~ **4.1.2.** Calculate the angular displacement from the output of instrumentation placed in the torso and head of the test dummy and an algorithm capable of determining the relative angular displacement to within one degree and conforming to the requirements of a 600 Hz channel class, as specified in SAE Recommended Practice J211/1, (revision March 1995). No data generated after 200ms from the beginning of the forward acceleration are used in determining angular displacement of the head with respect to the torso.

~~4.3.~~ **4.1.3.** Calculate the HIC15 from the output of instrumentation placed in the head of the test dummy, using the equation in paragraph 5.3.2.3. of this Regulation and conforming to the requirements for a 1,000 Hz channel class as specified in SAE Recommended Practice J211/1 (revision March 1995). No data generated after 200 ms from the beginning of the forward acceleration are used in determining HIC.

Table 9-1 8-1
Sled pulse corridor reference point locations

Reference Point	Time (ms)	Acceleration (m/s ²)
A	0	10
B	28	94
C	60	94
D	92	0
E	4	0
F	38.5	80
G	49.5	80
H	84	0

Figure 9-1 8-3
Sled pulse acceleration corridor

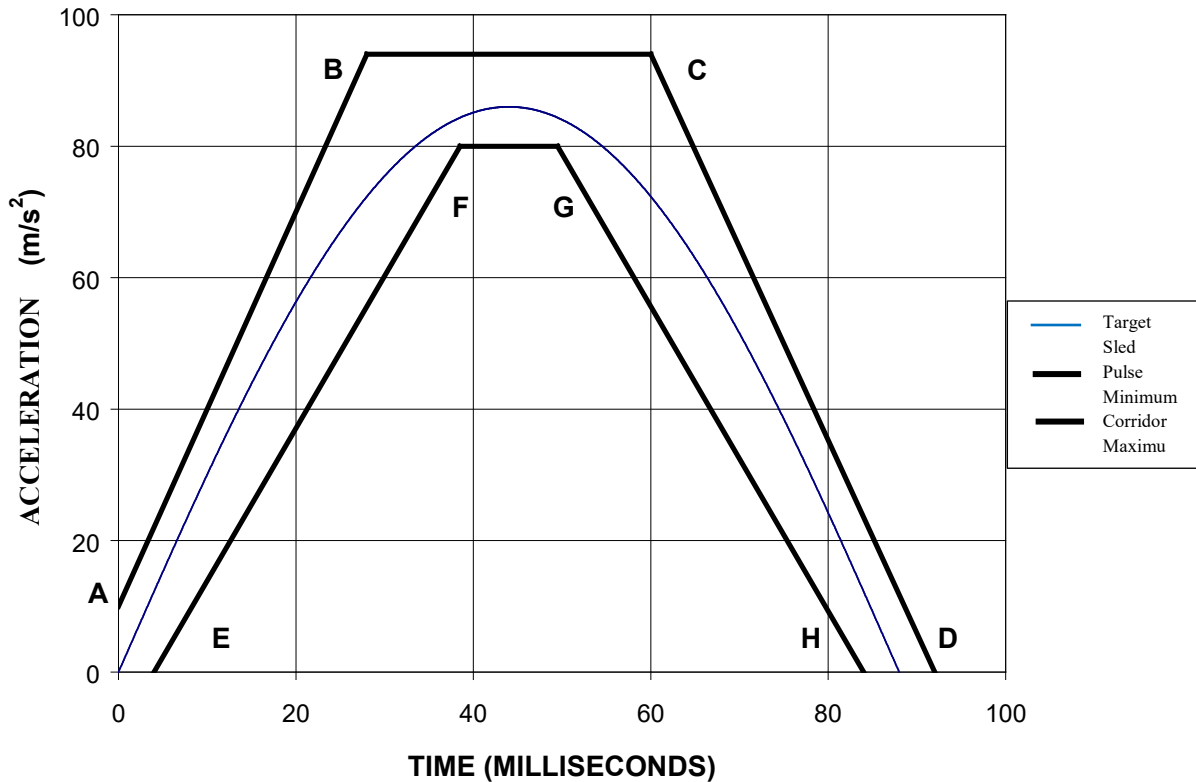

The target acceleration with time expressed in milliseconds is $a = 86 \sin(\pi t/88)$ m/s², for $\Delta V = 17.3 \pm 0.6$ km/h. The time zero for the test is defined by the point when the sled acceleration achieves 2.5 m/s² (0.25g's).

New elements 4.2. to 4.4. – have only had an initial review

4.2. Seat on Acceleration Sled (BioRID II).

The corridors for the pulse are illustrated in Figure 8-4. The sled acceleration shall be adjusted within the corridors described in Figure 8-3 and Table 8-2 for the complete time interval from 0 to 0.15s. The sled pulse shall fulfil the requirements as specified in Table 8-3.

Table 8-2
Acceleration versus time curve tolerances

		<i>Definition</i>	<i>Tolerance</i>	<i>Unit</i>
Velocity change	ΔV	17.6	± 0.9	km/h
Duration	ΔT	90.0	± 5.0	ms
Mean acceleration	Mean Acceleration	54.3	± 5.0	m/s ²
T=0 acceleration	AT0	0.0	± 3.0	m/s ²

Table 8-3
Sled pulse corridor reference point locations in Figure 8-3

Entry Gate

<i>Time (ms)</i>	<i>Slope-Upper (m/s²)</i>	<i>Time (ms)</i>	<i>Slope-Lower (m/s²)</i>
4.2	10.8	8.4	10.8
5.3	14.2	9.5	14.2
6.3	18.0	10.5	18.0
7.4	22.3	11.6	22.3
8.4	27.0	12.6	27.0
9.5	32.2	13.7	32.2
10.5	37.8	14.7	37.8
11.6	43.7	15.8	43.7
12.6	49.8	16.8	49.8
13.7	56.0	17.9	56.0
14.7	62.2	18.9	62.2
15.8	68.4	20.0	68.4
16.8	74.3	21.0	74.3
17.9	80.0	22.1	80.0
18.9	85.2	23.1	85.2

Peak Gate

<i>Time (ms)</i>	<i>Max-Horizontal (m/s²)</i>	<i>Time (ms)</i>	<i>Max-Vertical (m/s²)</i>
17.9	113.3	28.4	82.4
38.9	113.3	28.4	92.7

Exit Gate

<i>Time</i>	<i>1g Level-Upper (m/s²)</i>	<i>Time</i>	<i>1g Level-Lower(m/s²)</i>
105.0	10.3	105.0	-10.3
147.0	10.3	147.0	-10.3

Figure 8-4
Acceleration versus time curve and Permissible Range of curve for the test set-up according to section 3.2. (The target acceleration with time expressed in milliseconds shall meet the value in the table 8-3.)

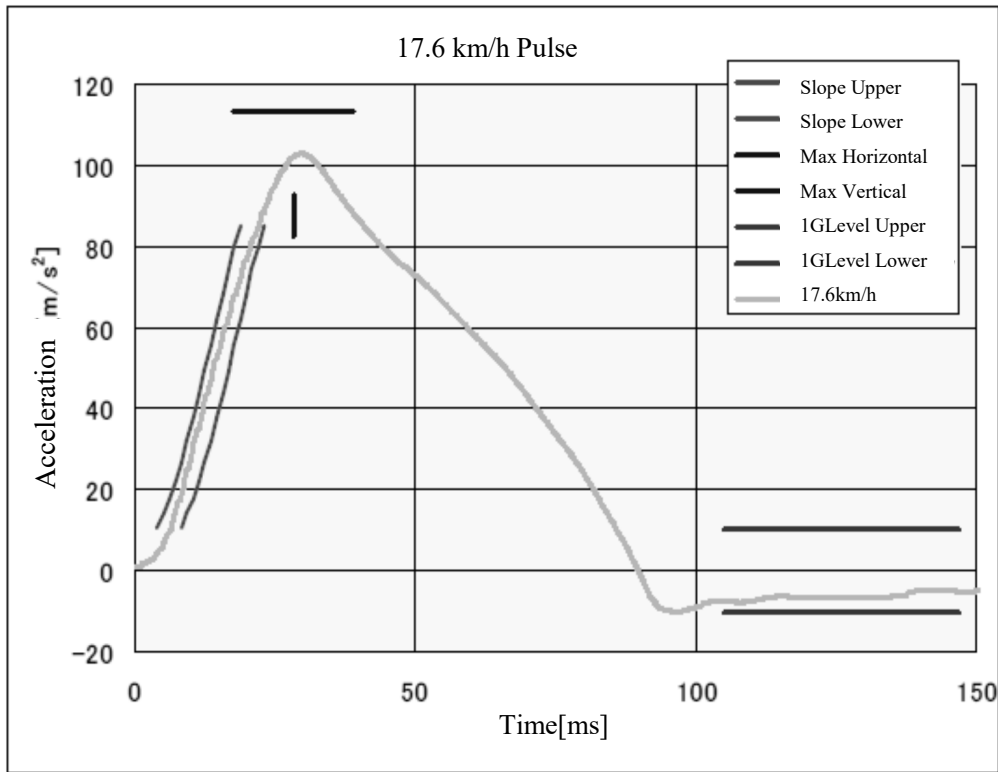

4.2.1. Data processing and definitions

4.2.1.1. Filter with CFC 60

To ensure that low level noise does not influence the results, the acceleration signal shall be filtered with a CFC 60 filter. The CFC 60 filter shall be used according to SAE J211, for sled acceleration signals.

4.2.1.2. T_0 definition

The $T_0(T_{zero})$ shall be defined as the time 5.8 ms before the CFC 60 filtered sled acceleration reaches a 1.0g level.

4.2.1.3. $T_{-HRC}(end)$ definition

The time when the CFC 60 filtered sled acceleration for the first time is $< 0g$ shall be called $T_{-HRC}(end)$.

4.2.1.4. Time span definition

The time span for sled pulse corridor shall be defined as $dT = T_{-HRC}(end) - T_0$.

4.2.1.5. Head and head restraint contact time ($T_{-HRCstart}$, $T_{-HRCend}$)

Head restraint contact time start, $T_{-HRCstart}$, is defined as the time (calculated from $T=0$) of first contact between the back of the dummy's head and the head restraint, where the subsequent continuous contact

duration exceeds 40 ms. T-HRCstart shall be expressed in ms and rounded to one decimal place. Two decimal places of contact time (up to 1 ms) are permissible] if it can be proven that these are due to poor electrical contacts; however, these must be investigated with reference to the film to ascertain whether the breaks in contact are not due to biomechanical phenomena such as dummy ramping, head restraint or seatback collapse, or "bounce" of the head during non-structural contact with the head restraint. For the subsequent criteria, the end of head restraint contact, i.e. T-HRCend, must also be found. This is defined as the time at which the head first loses contact with the head restraint, where the subsequent continuous loss of contact duration exceeds 40 ms.

4.3. Measurements to be recorded

The electrical measurement data for the following parameters from the accelerometers and load cells mounted on the corresponding parts of the dummy and on the test sled shall be recorded from 20 ms before impact to 300 ms after-impact or longer.

- (a) Longitudinal acceleration at the dummy's head;
- (b) Longitudinal force at the dummy's upper neck;
- (c) Vertical force at the dummy's upper neck;
- (d) Lateral axial rotation moment at the dummy's upper neck;
- (e) Longitudinal force at the dummy's lower neck;
- (f) Vertical force at the dummy's lower neck;
- (g) Lateral axial rotation moment at the dummy's lower neck;
- (h) Longitudinal acceleration on the right side of the dummy's T1 vertebra;
- (i) Vertical acceleration on the right side of the dummy's T1 vertebra;
- (j) Longitudinal acceleration on the left side of the dummy's T1 vertebra;
- (k) Vertical acceleration on the left side of the dummy's T1 vertebra;
- (l) Signal of contact between the back of the dummy's head and the head restraint.

4.4. Injury Criteria

The injury criteria for the dummy shall be calculated, using the following method, from the waveform determined in paragraph 4.3.

4.4.1. Neck Injury Criterion (NIC)

NIC is determined based on the velocity of the head relative to the T1 vertebra and horizontal acceleration. Each acceleration shall be calculated in meters per second squared (m/s^2), and the head's longitudinal acceleration shall be filtered at CFC 60. The T1 vertebra acceleration is measured on either side, but in the NIC calculation, the average of the left and right accelerations, which have both been filtered at CFC 60, shall be used.

This average acceleration is determined as follows:

$$T1(t) = \frac{T1_{left}(t) + T1_{right}(t)}{2}$$

T1left(t) = Acceleration measured by accelerometer on the left side of the T1 vertebra

T1right(t) = Acceleration measured by accelerometer on the right side of the T1 vertebra

The "relative longitudinal acceleration" between the head and T1 vertebra

(γ_x^{rel}) shall be generated by subtracting the head longitudinal acceleration

(γ_x^{Head}) from the left-right average of the T1 vertebra longitudinal acceleration (γ_x^{T1}).

This acceleration is calculated as follows:

$$\gamma_x^{rel} = \gamma_x^{T1} - \gamma_x^{Head}$$

The "relative longitudinal velocity" between the head and T1 vertebra (V_x^{rel}) shall be calculated, by integrating the relative acceleration with respect to time, as follows:

$$V_x^{rel}(t) = \int_0^t \gamma_x^{rel}(\tau) d\tau$$

The NIC channel is then calculated as a combination of relative acceleration multiplied by 0.2, and added to the square of the relative velocity. The calculation is performed using the following equation:

$$NIC(t) = 0.2 * \gamma_x^{rel}(t) + [V_x^{rel}(t)]^2$$

The maximum overall NIC value (NIC_{max}) shall be determined, considering only the portion of data from T=0 (start of test) until T-HRC(end) (end of contact between head and head restraint), as follows:

$$NIC_{max} = Max_{T-HRC(end)} [NIC(t)]$$

~~4.4.2. Upper neck shear force (Upper Neck Fx) and lower neck shear force (Lower Neck Fx)~~

~~These are shear forces measured by the dummy's upper neck and lower neck load cells assessed before the moment of rebound. If the instrumentation is configured in accordance with SAE J211 relative movement of the head rearward is considered positive and relative movement of the head forward is considered negative. positive shear force shall indicate a head rearward motion.~~

~~Data shall be filtered at CFC 1000, and the maximum absolute value of the force shall be determined, considering the portion of data from T=0 until T-HRC(end) and only the positive portion of data, as follows:~~

~~$$Fx_{max} = Max_{T-HRC(end)} [Fx(t)]$$
-Amend formula to add absolute.~~

4.4.3. ~~Upper neck lateral axial rotation moment (Upper Neck My)~~

~~This is lateral axial rotation moment measured by the dummy's upper neck load cell assessed before the moment of rebound.~~

~~If the instrumentation is configured in accordance with SAE J211, positive lateral axial rotation moment shall indicate flexion of the neck (head rotating forwards) and negative lateral axial rotation moment shall indicate extension (head rotating rearwards). Data shall be filtered at CFC 600. Due to the construction of the dummy, a correction shall then be made to convert the actual moment measured by the upper neck load cell into the moment about the occipital condyle (OC), as shown below:~~

~~$$My^{OC}(t) = My^{Upper}(t) - DFx^{Upper}(t)$$~~

~~$$D = 0.01778$$~~

~~The maximum absolute value of the moment about the OC shall be determined, considering the portion of data from T=0 until T-HRC(end).~~

~~$$My_{\max} = \underset{T-HRC_{(end)}}{Max} [My(t)]$$
 Amend formula to add absolute.~~

4.4.4. ~~Lower neck lateral axial rotation moment (Lower Neck My)~~

~~This is lateral axial rotation moment measured by the dummy's lower neck load cell assessed before the moment of rebound.~~

~~If the instrumentation is configured in accordance with SAE J211, positive lateral axial rotation moment shall indicate flexion of the neck (head rotating forwards) and negative lateral axial rotation moment shall indicate extension (head rotating rearwards). Data shall be filtered at CFC 600, and the maximum absolute value of the moment shall be determined, considering the portion of data from T=0 until T-HRC(end) and both the positive and negative portions of data, as follows:~~

~~$$My_{\max} = \underset{T-HRC_{(end)}}{Max} [My(t)]$$
 Amend formula to add absolute.~~

4.4.2. Upper neck shear force (Upper Neck Fx) and lower neck shear force (Lower Neck Fx)

These are shear forces measured by the dummy's upper neck and lower neck load cells assessed before the moment of rebound.

If the instrumentation is configured in accordance with SAE J211 relative movement of the head rearward is considered positive and relative movement of the head forward is considered negative. positive shear force shall indicate a head rearward motion.

Data shall be filtered at CFC 1000, and the maximum absolute value of the force shall be determined, considering the portion of data from T=0 until T-HRC(end) and only the positive portion of data, as follows:

$$Fx_{\max} = \underset{T-HRC_{(end)}}{Max} [|Fx(t)|]$$

4.4.3. Upper neck lateral axial rotation moment (Upper Neck My)

This is lateral axial rotation moment measured by the dummy's upper neck load cell **assessed before the moment of rebound**.

If the instrumentation is configured in accordance with SAE J211, positive lateral axial rotation moment shall indicate flexion of the **neck** (head rotating forwards) **and negative lateral axial rotation moment shall indicate extension (head rotating rearwards)**. Data shall be filtered at CFC 600. Due to the construction of the dummy, a correction shall then be made to convert the actual moment measured by the upper neck load cell into the moment about the occipital condyle (OC), as **shown below**:

$$My^{OC}(t) = My^{Upper}(t) - DFx^{Upper}(t)$$

$$D = 0.01778$$

The maximum absolute value of the moment about the OC shall be determined, considering the portion of data from T=0 until T-HRC(end).

$$My_{\max}^{OC} = \underset{T-HRC(end)}{Max} [|My^{OC}(t)|]$$

4.4.4. Lower neck lateral axial rotation moment (Lower Neck My)

This is lateral axial rotation moment measured by the dummy's lower neck load cell **assessed before the moment of rebound**.

If the instrumentation is configured in accordance with SAE J211, positive lateral axial rotation moment shall indicate flexion of the **neck** (head rotating forwards) **and negative lateral axial rotation moment shall indicate extension (head rotating rearwards)**. Data shall be filtered at CFC 600, and the maximum **absolute** value of the moment shall be determined, considering the portion of data from T=0 until T-HRC(end) **and both the positive and negative portions of data**, as follows:

$$My_{\max} = \underset{T-HRC(end)}{Max} [|My(t)|]$$

Annex 109

Non-use position test procedure

1. Purpose
Procedures for folding or retracting head restraints in all designated seating positions equipped with head restraints, except the driver's designated seating position.
2. Procedures to test automatic return head restraints
Demonstrate compliance with paragraph 5.4.4.1. with the ignition "on", and using a 5th percentile female Hybrid III test dummy¹ in accordance with paragraph 2.1. of this Annex, or a human surrogate in accordance with paragraph 2.2. of this Annex. Compliance is determined at a temperature of 18 to 28 °C.
 - 2.1. 5th percentile Hybrid III Dummy
 - 2.1.1. Position the test dummy in the seat such that the dummy's midsagittal plane is aligned within 15 mm of the seating position centreline and is parallel to a vertical plane parallel to the vehicle vertical longitudinal zero plane.
 - 2.1.2. Hold the dummy's thighs down and push rearward on the upper torso to maximize the dummy's pelvic angle.
 - 2.1.3. Place the legs as close as possible to 90° to the thighs. Push rearward on the dummy's knees to force the pelvis into the seat so there is no gap between the pelvis and the seat back or until contact occurs between the back of the dummy's calves and the front of the seat cushion such that the angle between the dummy's thighs and legs begins to change.
 - 2.1.4. Note the position of the head restraint. Remove the dummy from the seat. If the head restraint returns to a retracted position upon removal of the dummy, manually place it in the noted position. Determine compliance with the height requirements of paragraph 5.1.1. by using the test procedures of Annex 1.
 - 2.2. Human surrogate
A human being who weighs between 47 and 51 kg, and who is between 140 and 150 cm tall may be used. The human surrogate is dressed in a cotton T-shirt, full length cotton trousers, and sports shoes. Specified weights and heights include clothing.
 - 2.2.1. Position the human in the centre of the seat with the pelvis touching the seat back and the back against the seat back.
 - 2.2.2. Verify the human's midsagittal plane is vertical and within ± 15 mm of the seating position centreline.

¹ The technical specifications and detailed drawings of Hybrid III dummy, corresponding to the principal dimensions of a 5th percentile female of the United States of America, and the specifications for its adjustment for this test are deposited with the Secretary-General of the United Nations and may be consulted on request at the secretariat of the United Nations Economic Commission for Europe, Palais des Nations, Geneva, Switzerland.

- 2.2.3. Verify the transverse distance between the centres of the front of the knees is 160 to 170 mm. Centre the knee separation with respect to the seat centreline.
- 2.2.4. If needed, extend the legs until the feet do not contact the floor pan. The thighs are resting on the seat cushion.
- 2.2.5. If the human contacts the interior move the seat rearward until a maximum clearance of 5 mm is achieved or the seat is in the closest detent position which does not cause human contact.
- 2.2.6. Passenger foot positioning.
 - 2.2.6.1. Place feet flat on the toe board, or
 - 2.2.6.2. If the feet cannot be placed flat on the toe board, the feet are perpendicular to the lower leg, and the heel is as far forward as possible and resting on the floor pan, or
 - 2.2.6.3. If the heels do not touch the floor pan, the legs are vertical and the feet parallel to the floor pan.
- 2.2.7. Passenger arm/hand positioning.
 - 2.2.7.1. Place the human's upper arms adjacent to the torso with the arm centrelines as close to a vertical longitudinal plane as possible.
 - 2.2.7.2. Place the palms of the human in contact with the outer part of the thighs.
 - 2.2.7.3. Place the little fingers in contact with the seat cushion.
- 2.3. Start the vehicle engine or place the ignition in the "on" position, whichever will turn on the suppression system, and close all vehicle doors. Note the position of the head restraint. Remove the human from the seat. If the head restraint returns to a retracted position upon removal of the human, manually place it in the noted position. Determine compliance with the height requirements of paragraph 5.1.1. by using the test procedures of Annex 1.
- 2.4. Return the ignition switch to the "off" position.
- 3. 60° rotation evaluation

Procedures for the rear and front centre designated seating positions to demonstrate compliance with paragraph 5.4.4.2.

 - 3.1. Place the head restraint in any position meeting the requirements of paragraph 5.1.1.3. or paragraph 5.1.1.5. of the Regulation;
 - 3.1.1. Mark a line on the head restraint with one end at the point of rotation. Measure the angle or range of angles of the head restraint reference line as projected onto a vertical longitudinal vehicle plane;
 - 3.1.2. Fold or retract the head restraint to a position in which its minimum height is less than that specified in paragraph 5.1.1.3. or paragraph 5.1.1.5.;
 - 3.1.3. Determine the minimum change in the head restraint reference line angle as projected onto a vertical longitudinal vehicle plane from the angle or range of angles measured in paragraph 3.1.1. of this Annex.
- 4. Discomfort metric

Procedures for the rear and front centre designated seating positions to demonstrate compliance with paragraph 5.4.4.3. of this Regulation.

- 4.1. The H_{LE} and S dimensions are defined in Figure 40-19-1. Figure 40-19-1 is a vertical fore-aft plane passing through the R-point (i.e. at the mid-point of the designated seating position) intersecting the seat cushion, seat back and the head restraint.
- 4.2. Adjust the head restraint to the non-use position.
- 4.2.1. H_{LE} is the distance from the R-point to the lower edge of the head restraint measured along the torso line.
- 4.2.2. S is the maximum thickness of the head restraint (as determined within 25 mm of the head restraint lower edge) measured perpendicular to the torso line between T_H and T_S from line P.
- 4.2.3. P is a line parallel to the torso line which intersects the head restraint at T_S
- 4.2.4. T_H is the line perpendicular to the torso line and tangent to the lower edge of the head restraint.
- 4.2.5. T_S is the line parallel to and 25 mm from T_H .

Figure 40-19-1

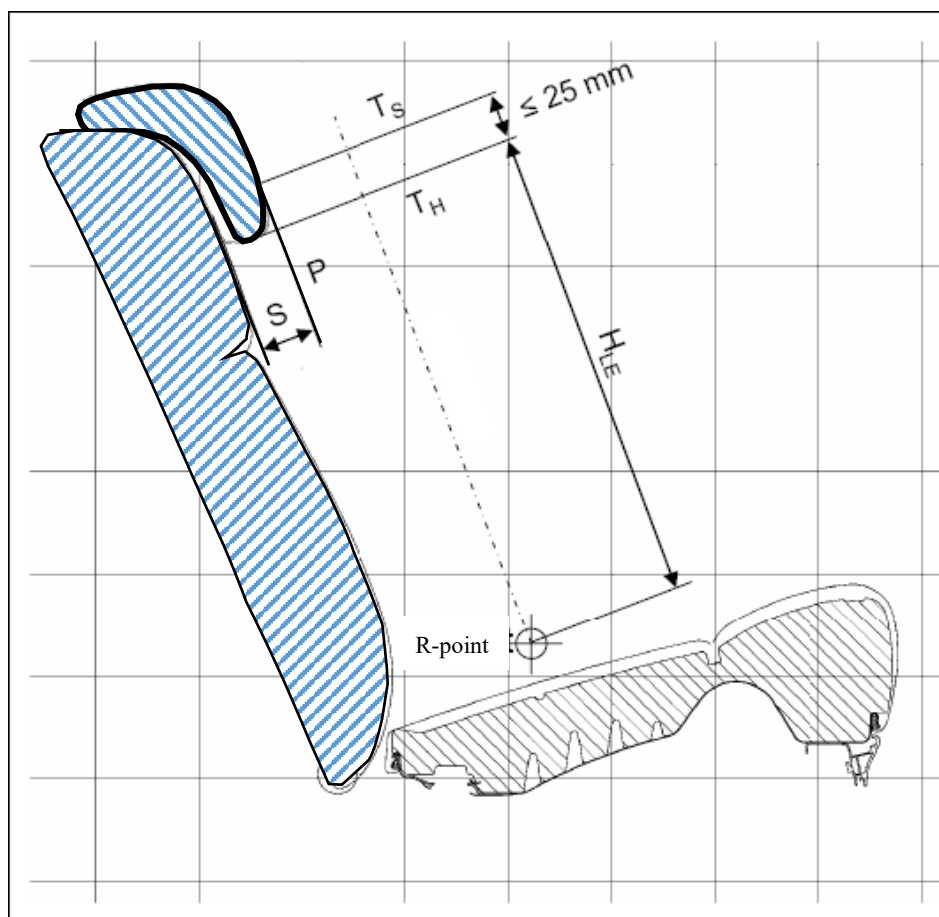

5. 10° **actual** torso ~~line~~ **angle** change
Procedures for the rear and front centre designated seating positions to demonstrate compliance with paragraph 5.4.4.4. **to this Regulation.**
- 5.1. Place the head restraint into any position meeting the requirements of paragraph 5.1.1 of this Regulation;
- 5.2. Measure the **actual** torso ~~line~~ angle with the three-dimensional H-point machine defined in Annex ~~13~~**12**;
- 5.3. Fold or retract the head restraint to any position in which its minimum height is less than that specified in paragraph 5.1.1. of this Regulation or in which its backset is more than that specified in paragraph 5.1.5. of this Regulation; and
- 5.4. Again measure the **actual** torso ~~line~~ angle.

Annex 110

Three-dimensional reference system

1. The three-dimensional reference system is defined by three orthogonal planes established by the vehicle manufacturer (see Figure 11-110-1).¹
2. The vehicle measuring attitude is established by positioning the vehicle on the supporting surface such that the co-ordinates of the fiducial marks correspond to the values indicated by the manufacturer.
3. The coordinates of the "R" point and the "H" point are established in relation to the fiducial marks defined by the vehicle manufacturer.

Figure 11-110-1

Three-dimensional reference system

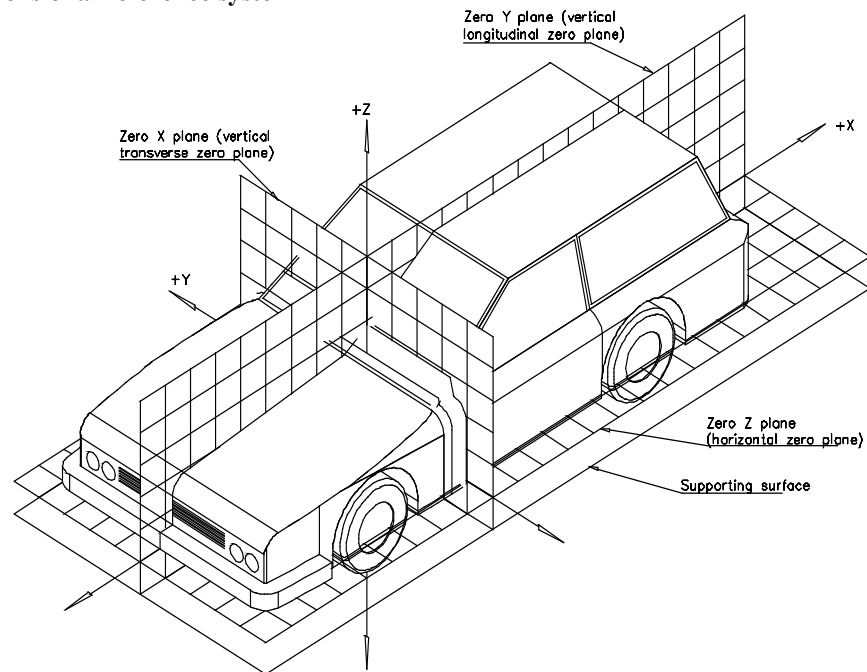

Figure – Three dimensional reference system

¹ The reference system corresponds to ISO standard 4130: 1978.

Annex ~~12~~11

Procedure for validation of the H-point and R-point relationship for seating positions in motor vehicles

1. Purpose
The procedure described in this Annex is used to establish the H-point location and the actual torso angle for one or several seating positions in a motor vehicle and to verify the relationship of measured data to design specifications given by the vehicle manufacturer.
2. Definitions
For the purposes of this Annex:
 - 2.1. "*Reference data*" means one or several of the following characteristics of a seating position:
 - 2.1.1. the H- point and the R-point and their relationship;
 - 2.1.2. the actual torso angle and the design torso angle and their relationship.
 - 2.2. "*Three-dimensional H-point machine (3-D H machine)*" means the device used for the determination of H-points and actual torso angles. This device is described in Annex ~~13~~12;
 - 2.3. "*Centre plane of occupant (C/LO)*" means the median plane of the 3-D H machine positioned in each designated seating position; it is represented by the coordinate of the H-point on the "Y" axis. For individual seats, the centre plane of the seat coincides with the centre plane of the occupant. For other seats, the centre plane of the occupant is specified by the manufacturer;
 - 2.4. "*Three-dimensional reference system*" means a system as described in Annex ~~11~~10;
 - 2.5. "*Fiducial marks*" are physical points (holes, surfaces, marks or indentations) on the vehicle body as defined by the manufacturer;
 - 2.6. "*Vehicle measuring attitude*" means the position of the vehicle as defined by the coordinates of fiducial marks in the three-dimensional reference system.
3. Procedure for H-point and actual torso angle determination
 - 3.1. The vehicle is preconditioned at a temperature of $20\text{ °C} \pm 10\text{ °C}$ to ensure that the seat material reaches room temperature.
 - 3.2. The vehicle is at the measuring attitude defined in paragraph 2.6. of this Annex.
 - 3.3. The seat, if it is adjustable, is adjusted first to the rearmost normal driving position, as indicated by the vehicle manufacturer, taking into consideration only the longitudinal adjustment of the seat, excluding seat travel used for purposes other than normal driving positions. Where other modes of seat adjustment exist (vertical, angular, seat back, etc.) these will be then adjusted to the position specified by the vehicle manufacturer. For suspension seats, the vertical position is rigidly fixed corresponding to a normal driving position as specified by the manufacturer.

- 3.4. The area of the seating position contacted by the 3-D H machine is covered by a muslin cotton, of sufficient size and appropriate texture, described as a plain cotton fabric having 18.9 threads per cm² and weighing 0.228 kg/m² or knitted or non-woven fabric having equivalent characteristics.
- If the test is run on a seat outside the vehicle, the floor on which the seat is placed shall have the same essential characteristics (tilt angle, height difference with a seat mounting, surface texture, etc.) as the floor of the vehicle in which the seat is intended to be used.
- 3.5. Place the seat and back assembly of the 3-D H machine so that the centre plane of the occupant (C/LO) coincides with the centre plane of the 3-D H machine. At the manufacturer's request, the 3-D H machine may be moved inboard with respect to the C/LO if the 3-D H machine is located so far outboard that the seat edge will not permit levelling of the 3-D H machine.
- 3.6. Attach the foot and lower leg assemblies to the seat pan assembly, either individually or by using the T bar and lower leg assembly. A line through the "H" point sight buttons is parallel to the ground and perpendicular to the longitudinal centre plane of the seat.
- 3.7. Adjust the feet and leg positions of the 3-D H machine as follows:
- 3.7.1. In the case of front outboard seats:
- 3.7.1.1. Both feet and leg assemblies are moved forward in such a way that the feet take up natural positions on the floor, between the operating pedals if necessary. Where possible the left foot is located approximately the same distance to the left of the centre plane of the 3-D H machine as the right foot is to the right. The spirit level verifying the transverse orientation of the 3-D H machine is brought to the horizontal by readjustment of the seat pan if necessary, or by adjusting the leg and foot assemblies towards the rear. The line passing through the H-point sight buttons is maintained perpendicular to the longitudinal centre plane of the seat.
- 3.7.1.2. If the left leg cannot be kept parallel to the right leg and the left foot cannot be supported by the structure, move the left foot until it is supported. The alignment of the sight buttons is maintained.
- 3.7.2. In the case of rear outboard seats:
- For rear seats or auxiliary seats, the legs are located as specified by the manufacturer. If the feet then rest on parts of the floor which are at different levels, the foot which first comes into contact with the front seat shall serve as a reference and the other foot is so arranged that the spirit level giving the transverse orientation of the seat of the device indicates the horizontal.
- 3.7.3. In the case of other seats:
- The general procedure indicated in paragraph 3.7.1. of this Annex is followed except that the feet are placed as specified by the vehicle manufacturer.
- 3.8. Apply lower leg and thigh weights and level the 3-D H machine.
- 3.9. Tilt the back pan forward against the forward stop and draw the 3-D H machine away from the seat back using the T bar. Reposition the 3-D H machine on the seat by one of the following methods:
- 3.9.1. If the 3-D H machine tends to slide rearward, use the following procedure. Allow the 3-D H machine to slide rearward until a forward horizontal

- restraining load on the T bar is no longer required i.e. until the seat pan contacts the seat back. If necessary, reposition the lower leg.
- 3.9.2. If the 3-D H machine does not tend to slide rearward, use the following procedure. Slide the 3-D H machine rearwards by applying a horizontal rearward load to the T bar until the seat pan contacts the seat back (see Figure ~~13-212-2~~ of Annex ~~1312~~).
- 3.10. Apply a 100 ± 10 N load to the back and pan assembly of the 3-D H machine at the intersection of the hip angle quadrant and the T bar housing. The direction of load application is maintained along a line passing by the above intersection to a point just above the thigh bar housing (see Figure ~~13-212-2~~ of Annex ~~1312~~). Then carefully return the back pan to the seat back. Care must be exercised throughout the remainder of the procedure to prevent the 3-D H machine from sliding forward.
- 3.11. Install the right and left buttock weights and then, alternately, the eight torso weights. Maintain the 3-D H machine level.
- 3.12. Tilt the back pan forward to release the tension on the seat back. Rock the 3-D H machine from side to side through 10° arc (5° to each side of the vertical centre plane) for three complete cycles. ~~to release any accumulated friction between the 3-D H machine and the seat.~~
- 3.12.1. During the rocking action, the T bar of the 3-D H machine may tend to diverge from the specified horizontal and vertical alignment. The T bar must therefore be restrained by applying an appropriate lateral load during the rocking motions. Care is exercised in holding the T bar and rocking the 3-D H machine to ensure that no inadvertent exterior loads are applied in a vertical or fore and aft direction.
- 3.12.2. The feet of the 3-D H machine are not to be restrained or held during this step. If the feet change position, they should be allowed to remain in that attitude for the moment.
- 3.12.3. Carefully return the back pan to the seat back and check the two spirit levels for zero position. If any movement of the feet has occurred during the rocking operation of the 3-D H machine, they must be repositioned as follows:
- 3.12.4. Alternately, lift each foot off the floor the minimum necessary amount until no additional foot movement is obtained. During this lifting, the feet are to be free to rotate; and no forward or lateral loads are to be applied. When each foot is placed back in the down position, the heel is to be in contact with the structure designed for this.
- 3.12.5. Check the lateral spirit level for zero position; if necessary, apply a lateral load to the top of the back pan sufficient to level the 3-D H machine's seat pan on the seat.
- 3.13. Holding the T bar to prevent the 3-D H machine from sliding forward on the seat cushion, proceed as follows:
- 3.13.1. Return the back pan to the seat back;
- 3.13.2. Alternately apply and release a horizontal rearward load, not to exceed 25 N, to the back angle bar at a height approximately at the centre of the torso weights until the hip angle quadrant indicates that a stable position has been reached after load release. Care is exercised to ensure that no exterior downward or lateral loads are applied to the 3-D H machine. If another level adjustment of

the 3-D H machine is necessary, rotate the back pan forward, re-level, and repeat the procedure from paragraph 3.12. of this Annex.

- 3.14. Take all measurements:
 - 3.14.1. The coordinates of the "H" point are measured with respect to the three-dimensional reference system.
 - 3.14.2. The actual torso angle is read at the back angle quadrant of the 3-D H machine with the probe in its fully rearward position.
- 3.15. If a re-run of the installation of the 3-D H machine is desired, the seat assembly should remain unloaded for a minimum period of 30 minutes prior to the rerun. The 3-D H machine should not be left loaded on the seat assembly longer than the time required to perform the test.
- 3.16. If the seats in the same row can be regarded as similar (bench seat, identical seats, etc.) only one "H" point and one "actual torso angle" is determined for each row of seats, the 3-D H machine described in Annex ~~4~~³12 being seated in a place regarded as representative for the row. This place is:
 - 3.16.1. In the case of the front row, the driver's seat;
 - 3.16.2. In the case of the rear row or rows, an outer seat.

Annex 1312

Description of the three-dimensional H-point machine ¹ (3-D H machine)

1. Back and seat pans
The back and seat pans are constructed of reinforced plastic and metal; they **simulate** the human torso and thigh and are mechanically hinged at the "H" point. A quadrant is fastened to the probe hinged at the H-point to measure the actual torso angle. An adjustable thigh bar, attached to the seat pan, establishes the thigh centreline and serves as a baseline for the hip angle quadrant.
2. Body and leg elements
Lower leg segments are connected to the seat pan assembly at the T bar joining the knees, which is a lateral extension of the adjustable thigh bar. Quadrants are incorporated in the lower leg segments to measure knee angles. Shoe and foot assemblies are calibrated to measure the foot angle. Two spirit levels orient the device in space. Body element weights are placed at the corresponding centres of gravity to provide seat penetration equivalent to a 76 kg male. All joints of the 3-D H machine should be checked for free movement without encountering noticeable friction.

¹— ~~For details of the construction of the 3-D H machine refer to Society of Automotive Engineers (SAE), 400 Commonwealth Drive, Warrendale, Pennsylvania 15096, United States of America [(SAE J826 1995 version)]. The machine corresponds to that described in ISO Standard 6549: 1999.~~

The machine corresponds to that described in ISO Standard 6549-1980. For details of the construction of the 3-DH machine refer to Society of Automotive Engineers (SAE), 400 Commonwealth Drive, Warrendale, Pennsylvania 15096, United States of America.

Figure 41-12-1
 3-D H machine elements designation

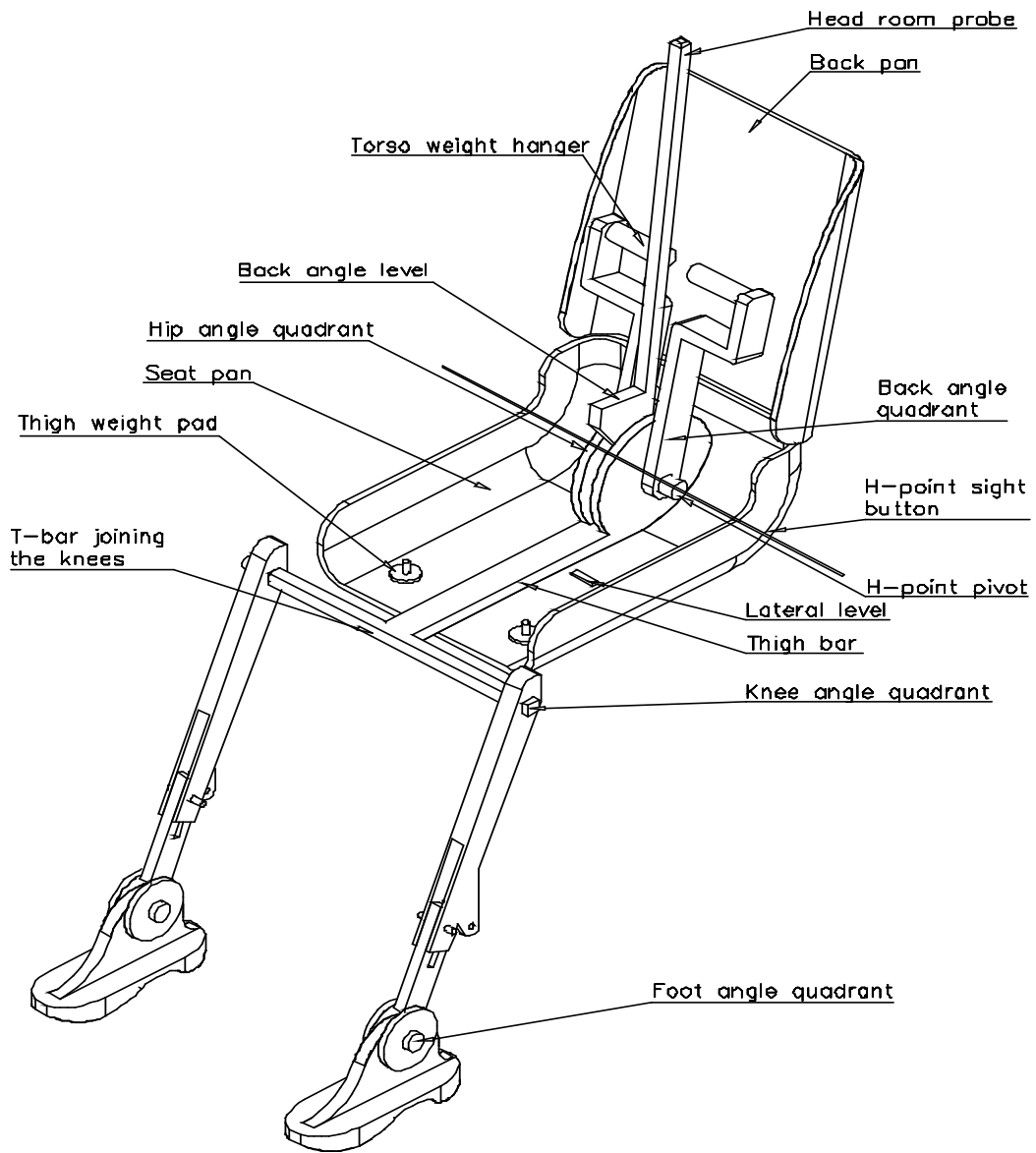
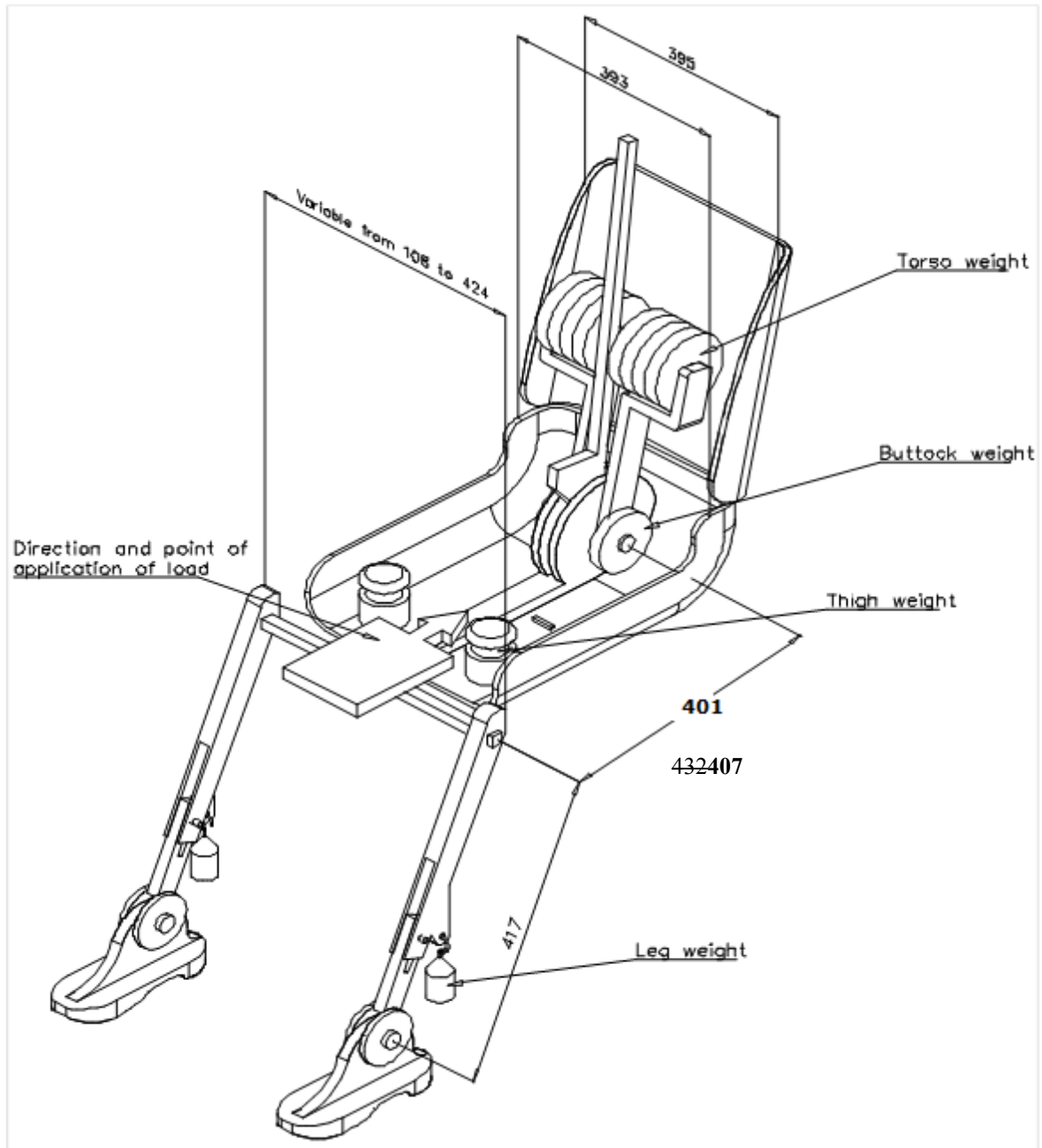

Figure 41-212-2
Dimensions of the 3-D H machine elements and load distribution
(Dimensions in millimetres)



II. Justification

1. GTR7 IWG was charged with considering amendments to UN Global Technical Regulation No. 7 in the areas of head restraint height, with introducing the anthropometric test device – BioRID (Biofidelic Rear Impact Device) and with amendments of an editorial nature. The latest IWG developments are presented in this working paper.

2. Part A (Statement of Technical Rationale and Justification) of the proposed amendments has not been drafted in full and the text, as presented in this document, does not represent any final output from IWG.

3. Annex 1 is the new procedure recommended by IWG to establish the effective height of the head restraint. This approach was presented at the fifty-third session of GRSP for discussion. Notwithstanding paragraph 2 above, a description of this new approach is presented in Part A.

4. The members of IWG developed this approach at a workshop and extended the principles to the seating procedures for the BioRID ATD. This procedure, which has yet to be reviewed by all IWG members, is set out in Annex 9.

5. IWG reviewed the absolute height requirement for a head restraint, but are of the opinion that the issue cannot be solved in isolation, and requested GRSP to reinstate this item in the formal agenda of the fifty-third session.

6. Concerns were raised in IWG on the dimensional variation of 3-D H machines. The trend in seat design to include more pronounced lateral support, coupled with variation in the width of the 3-D H device, present a risk to the consistent identification of the H-point. At its fifty-third session, GRSP indicated that the 3-D H machine might be more appropriate in Mutual Resolution No. 1 rather than in individual Regulations and UN GTRs.

7. Final recommendations for the use of BioRID depend on both the progress in concluding the build level of the device and on the injury criteria to be used. This work is ongoing and IWG is not currently in a position to make recommendations.

8. Nevertheless, this document presents indicative values for injury criteria based upon the current status of the work and initial text which defines the handling and the use of the tool together with recommendations for the appropriate sled pulse.

~~9. — Part B contains the core text of the proposal and uses [square brackets] to indicate that issues are still subject to final agreement by IWG.~~

~~10~~ 9. At the sixty-fourth session of GRSP, IWG submitted ECE/TRANS/WP.29/GRSP/2018/27, and Japan and the European Commission submitted ECE/TRANS/WP.29/GRSP/2018/34 as a proposal for the 10 series of amendments to UN Regulation No. 17 for alignment with UN GTR No. 7, Phase 2. However, since there were many square brackets in the document, Japan, Germany and the Netherland submitted GRSP-64-39-Rev1 as an informal document without square brackets.

~~11~~ 10. Based on the three documents mentioned above, the experts from Japan and CLEPA organized a webex meeting to discuss some concerns that were raised during the sixty-fourth GRSP session. Most of concerns for alignment with UN GTR No. 7, Phase 1 were agreed on, except injury criteria, which are planned for discussion at the coming GTR7 IWG meeting.