



Economic and Social Council

Distr.: General
9 April 2018

Original: English

Economic Commission for Europe

Inland Transport Committee

World Forum for Harmonization of Vehicle Regulations

175th session

Geneva, 19-22 June 2018

Item 4.12.2 of the provisional agenda

1958 Agreement:

**Consideration of proposals for new UN Regulations submitted
by the Working Parties subsidiary to the World Forum**

Proposal for a new UN Regulation on uniform provisions concerning the approval of mechanical coupling components of combinations of agricultural vehicles

Submitted by the Working Party on Brakes and Running Gear*

The text reproduced below was adopted by the Working Party on Brakes and Running Gear (GRRF) at its eighty-sixth session (ECE/TRANS/WP.29/GRRF/86, para. 18). It is based on ECE/TRANS/WP.29/GRRF/2018/4. It is submitted to the World Forum for Harmonization of Vehicle Regulations (WP.29) and to the Administrative Committee AC.1 for consideration at their June 2018 sessions.

* In accordance with the programme of work of the Inland Transport Committee for 2018–2019 (ECE/TRANS/274, para. 123 and ECE/TRANS/2018/21/Add.1, cluster 3.1), the World Forum will develop, harmonize and update UN Regulations in order to enhance the performance of vehicles. The present document is submitted in conformity with that mandate.

Uniform provisions concerning the approval of mechanical coupling components of combinations of agricultural vehicles

Contents

	<i>Page</i>
Regulation	
1. Scope	3
2. Definitions.....	3
3. Application for approval of a mechanical coupling device or component	8
4. General requirements for mechanical coupling devices or components	9
5. Application for approval of a vehicle fitted with a mechanical coupling device or component	10
6. General requirements for vehicles fitted with a mechanical coupling device or component	10
7. Markings	11
8. Approval	11
9. Modifications of the mechanical coupling device or component, or of the vehicle and extension of approval	12
10. Conformity of production procedures	13
11. Penalties for non-conformity of production	13
12. Production definitively discontinued.....	13
13. Names and addresses of Technical Services responsible for conducting approval tests and of Type Approval Authorities.....	13
Annexes	
1 Communication concerning devices and components.....	14
2 Communication concerning vehicles	16
3 Example of an arrangement of the approval mark	18
4 Examples of arrangements of marking of the characteristic values	19
5 Requirements for mechanical coupling devices or components for vehicles of categories T, R and S	20
6 Testing of mechanical coupling devices or components for vehicles of categories T, R and S	36
7 Installation and special requirements	43

1. Scope

- 1.1. This Regulation lays down the requirements which mechanical coupling devices and components shall meet in order to be regarded internationally as being mutually compatible and interchangeable.
- 1.2. This Regulation applies to devices and components intended for vehicles of category T, R or S¹ (agricultural vehicles) intended to form a combination of vehicles.²
- 1.3. This Regulation applies to:
 - 1.3.1. Standard devices and components as defined in paragraph 2.2.;
 - 1.3.2. Non-standard devices and components as defined in paragraph 2.3.;
 - 1.3.3. Non-standard miscellaneous devices and components as defined in paragraph 2.4.
- 1.4. This regulation does not apply to power lifts (three-point hitch) or tractor lower link arms and their connections to the towed vehicle.

2. Definitions

For the purposes of this Regulation:

- 2.1. "*Mechanical coupling devices and components*" means all those items on the frame, load-bearing parts of the bodywork and the chassis of the motor vehicle and trailer by means of which they are connected together to form the combination of vehicles or the articulated vehicles. Fixed, movable or detachable parts for the attachment or operation of the mechanical coupling device or component are included.
 - 2.1.1. Automatic coupling requirement is achieved if reversing the towing vehicle against the trailer is sufficient to engage the coupling completely, to lock it automatically and to indicate proper engagement of the locking devices without any external intervention.
- 2.2. "*Standard mechanical coupling devices and components*" conform to standard dimensions and characteristic values as given in this Regulation. They are interchangeable within their class, independent of manufacturer with regard to mounting dimensions and may be connected to standard mechanical coupling devices and components of the appropriate class in accordance with Annex 5 Table 2.
- 2.3. "*Non-standard mechanical coupling devices and components*" do not conform in all respects to the standard dimensions and characteristic values given in this Regulation but can be connected to standard coupling devices and components in the relevant class.
- 2.4. "*Non-standard miscellaneous mechanical coupling devices and components*" do not conform to standard dimensions and characteristic values as given in this

¹ As defined in the Consolidated Resolution on the Construction of Vehicles (R.E.3.), document ECE/TRANS/WP.29/78/Rev.6, para. 2 - www.unece.org/trans/main/wp29/wp29wgs/wp29gen/wp29resolutions.html

² Within the meaning of the Convention on Road Traffic (Vienna, 1968, article 1, sub-paragraphs (t) and (u)).

Regulation and cannot be connected to standard coupling devices and components. They include, for example, devices which do not correspond with any of the classes a to r listed in paragraph 2.6., but conforming to existing national and international standards.

- 2.5. Towing frames may comprise more than one component and can be quick height adjustable or adjusted by pins.

This Regulation applies to towing frames which are separate units, not a structural part of the tractor.

- 2.6. Mechanical coupling devices and components are classified according to type as follows:

- 2.6.1. Class a80 Coupling ball 80 and keeper plate employing a spherical device and brackets on the towing vehicle for connecting to the trailer by means of a ball-shaped scraper Coupling head 80.
- 2.6.2. Class b80 Coupling head 80 have a 80mm spherical cavity, fitted to the drawbar of trailer for connecting to Coupling ball 80.
- 2.6.3. Class c40 Clevis-type drawbar couplings with a pin (30 mm to 38 mm diameter), a jaw and an automatic or non-automatic closing and locking pin on the towing vehicle for connecting to the trailer by means of a coupling ring
- 2.6.4. Class d40-1 Drawbar eyes 40 having a cylindrical hole suitable for a pin (30 mm to 38 mm diameter) and a nominal thickness of 30,5 mm, and fitted to the drawbar of trailers for connecting to clevis-type couplings.
- 2.6.5. Class d40-2 Drawbar eyes 40 having a cylindrical hole suitable for a pin (30 mm to 38 mm diameter) and a nominal thickness of 42 mm, fitted to the drawbar of a trailer for connecting to a clevis-type coupling.
- 2.6.6. Class d50 Toroidal drawbar eye having a hole with a 50 mm diameter, which are fitted to trailer drawbars for connecting to a hitch hook (class g) or a piton-type coupling (class h)
- 2.6.6.1. Class d50-1 Toroidal drawbar eye having a hole with a 50 mm diameter and a nominal diameter of the cross section of 30 mm, which are fitted to trailer drawbars for connecting to a hitch hook (class g) or a piton-type coupling (class h)
- 2.6.6.2. Class d50-2 Toroidal drawbar eye having a hole with a 50 mm diameter and a diameter of the cross section of 41 mm max., which are fitted to trailer drawbars for connecting to a hitch hook (class g)
- 2.6.7. Class e Non-standard drawbars comprising forked and other drawbars, overrun devices and similar items

- of equipment mounted on the front of the towed vehicle, or on the vehicle chassis, which are suitable for coupling to the towing vehicle by means of coupling rings. Drawbar eyes, ball-shaped scrapers coupling head or similar coupling devices.
- Drawbars may be hinged to move freely in a vertical plane and not support any vertical load or be fixed in a vertical plane so as to support a vertical load (rigid drawbars). Rigid drawbars can be entirely rigid or be spring-mounted or adjustably (e.g. hydraulically) mounted.
- Drawbars may also comprise more than one component and may be adjustable or cranked.
- 2.6.8. Class f Non-standard towing frames comprising all components and devices between the coupling devices, such as clevis coupling, ball coupling etc, and the rear part of the tractor (for example transmission, the load-bearing bodywork or the chassis).
- 2.6.9. Class g Hitch hooks with a keeper plate and a lowering device operated using external power for remote-controlled coupling and uncoupling for connecting to the trailer using hitch rings or drawbar eyes.
- 2.6.10. Class h Piton-type couplings with a keeper plate which are connected to the trailer by means of hitch rings drawbar eyes.
- 2.6.11. Class i Tractor drawbar couplings non-swivel around longitudinal axis.
- 2.6.12. Class j Drawbar eyes which are fitted to trailer drawbars for connecting to a tractor drawbar (class i).
- 2.6.13. Class q Clevis-type drawbar couplings non-swivel around longitudinal axis.
- 2.6.14. Class r Drawbar eye, swivel around longitudinal axis, having a circular cross-section and fitted to the drawbar of trailers for connection with non-swivel clevis type couplings (class q).
- 2.6.15. Class s Coupling devices and components which do not conform to any of the classes a to r and which are used for special applications and which are generally covered by existing national or international standards (unique to some countries).
- 2.7. *"Remote control systems are devices and components"* which enable the coupling device to be operated from the side of the vehicle or from the driving cab of the vehicle.

- 2.8. "Remote indicators are devices and components" which give an indication that coupling has been effected and that the locking devices have engaged.
- 2.9. "Type of coupling device or component" means a device or component which does not differ in such essential respects as:
 - 2.9.1. The manufacturer's or supplier's trade name or mark;
 - 2.9.2. The class of coupling as defined in paragraph 2.6.;
 - 2.9.3. The external shape, principal dimensions or fundamental difference in design including materials used; and
 - 2.9.4. The characteristic values D, D_c, S, A_v and V as defined in paragraph 2.10.
- 2.10. The characteristic values D, D_c, S, A_v and V are defined or determined as:
 - 2.10.1. The D or D_c value is the theoretical reference value for the horizontal forces in the towing vehicle and the trailer and is used as the basis for horizontal loads in the dynamic tests.

For mechanical coupling devices and components not designed to support imposed vertical loads, the value is:

$$D = g \frac{T \cdot R}{T + R} \text{ [kN]}$$

For mechanical coupling devices and components for rigid drawbar trailers as defined in 2.12., the value is:

$$D_c = g \frac{T \cdot C}{T + C} \text{ [kN]}$$

Where:

- T is the technically permissible maximum mass of the towing vehicle, in tonnes. Where relevant, this includes the vertical load imposed by a rigid drawbar trailer.³
- R is the technically permissible maximum mass, in tonnes, of a trailer with drawbar free to move in a vertical plane, or of a semitrailer.³
- C is the mass, in tonnes, transmitted to the ground by the axle or axles of the rigid drawbar trailer, as defined in paragraph 2.12., when coupled to the towing vehicle and loaded to the technically permissible maximum mass.²
- g is the acceleration due to gravity (assumed to be 9.81 m/s²)
- S is as defined in paragraph 2.10.2.
- 2.10.2. The S value is the vertical mass, in kilograms, imposed on the coupling, under static conditions, by the rigid drawbar trailer, as defined in paragraph 2.12., of technically permissible maximum mass.³
- 2.10.3. The A_v value is the maximum permitted axle mass of the steered axle in tonnes in case of trailers with hinged drawbars.

³ The mass T and R and the technically permissible maximum mass, may be greater than the permissible maximum mass prescribed by national legislation.

- 2.10.4. The V value is the theoretical reference value of the amplitude of the vertical force imposed on the coupling by the rigid drawbar trailer of technically permissible maximum mass greater than 3.5 tonnes. The V value is used as the basis for vertical forces in the dynamic tests.

$$V = 1.44 \cdot 1.8 \frac{m}{s^2} \cdot C \text{ [kN]}$$

- 2.11. Symbols and definitions used in Annex 6 to this Regulation.

- A_v = maximum permitted axle mass of the steered axle in tonnes in case of trailers with hinged drawbars.
- C = mass of rigid drawbar trailer in tonnes – see paragraph 2.10.1. of this Regulation.
- D = D value in kN - see paragraph 2.10.1. of this Regulation.
- D_c = D_c value in kN for rigid drawbar trailers - see paragraph 2.10.1. of this Regulation.
- R = mass of towed vehicle in tonnes - see paragraph 2.10.1. of this Regulation.
- T = mass of towing vehicle in tonnes - see paragraph 2.10.1. of this Regulation.
- F_s = static lifting force in kN.
- F_h = horizontal component of test force in longitudinal axis of vehicle in kN.
- F_v = vertical component of test force in kN.
- S = static vertical mass in kg.
- V = V-value in kN - see paragraph 2.10.4. of this Regulation.
- g = acceleration due to gravity, assumed as 9.81 m/s².
- v_{\max} = v_{\max} is the maximum design speed for which the coupling device resp. the vehicle is tested and approved with regards to this regulation

Subscripts:

- O = maximum test force
- U = minimum test force
- s = static force
- h = horizontal
- p = pulsating
- res = resultant
- v = vertical
- w = alternating force
- 2.12. "*Rigid drawbar trailer*" means a towed vehicle with one axle or axle group, a drawbar which is not able to rotate relative to the vehicle or, due to the presence

of a suspension system (for example), can only rotate to a limited extent about one axis – parallel to the road surface and transverse to the direction of travel – and is therefore able to transmit vertical forces to the towing vehicle. A part of the weight of such a trailer is borne by the towing vehicle. A hydraulically adjustable articulated drawbar is considered to be a rigid drawbar.⁴

- 2.13. "*Positive mechanical engagement*" means that the design and geometry of a device and its component parts shall be such that it will not open or disengage under the action of any forces or components of forces to which it is subject during normal use or testing.
- 2.14. "*Vehicle type*" means vehicles which do not differ in such essential respects as the structure, dimensions, shape and materials in areas to which the mechanical coupling device or component is affixed. This applies to both the towing vehicle and trailer.

3. Application for approval of a mechanical coupling device or component

- 3.1. The application for approval shall be submitted by the holder of the trade name or mark or by his duly accredited representative.
- 3.2. For each type of mechanical coupling device or component the application shall be accompanied by the following information, for example, by means of the Communication form given in Annex 1:
- 3.2.1. Details of all manufacturer's or supplier's trade names or marks to be applied to the coupling device or component;
- 3.2.2. Drawings which are sufficiently detailed to define the device or component and which specify how it is to be fitted to the vehicle; the drawings shall show the position and space provided for the approval number and other marking as given in paragraph 7.;
- 3.2.3. A statement of the values of D, D_c, S, A_v and V as applicable and as defined in paragraph 2.10.
- 3.2.3.1. The characteristic values of the coupling devices shall be at least equal to those applicable to the maximum permissible towing vehicle, trailer and combination masses.
- 3.2.4. A detailed technical description of the device or component, specifying, in particular, the type and the materials used;
- 3.2.5. Samples as requested by the Type Approval Authority or Technical Service;
- 3.2.6. All samples shall be fully finished with the final surface treatment applied. However, if the final treatment is by painting or epoxy powder coating, this should be omitted;

⁴ The mass T and R and the technically permissible mass may be greater than the maximum permissible mass prescribed by national legislation.

4. General requirements for mechanical coupling devices or components

- 4.1. Each sample shall conform to the dimensional and strength specifications set out in Annexes 5 and 6. Following the tests specified in Annex 6 there shall not be any cracks, fractures or any excessive permanent distortion which would be detrimental to the satisfactory operation of the device or component.
- 4.2. All parts of the mechanical coupling device or component whose failure could result in separation of the vehicle and trailer shall be made of steel or cast iron. Other materials may be used provided that equivalence has been demonstrated by the manufacturer to the satisfaction of the Type Approval Authority or Technical Service of the Contracting Party applying this Regulation.
- 4.3. The mechanical coupling devices or components shall be safe to operate and coupling and uncoupling shall be possible by one person without the use of tools. Coupling devices intended for trailers having a maximum technically permissible mass greater than 3.5 tonnes shall be of either one of the following type:
- (a) Automatic coupling defined in 2.2, or
 - (b) Automated coupling and locking process where the initiated coupling process is automatically finalized and the locked position indicated in the driver's field of vision, or
 - (c) Manually locked and secured with no automation or selflocking device.
- 4.4. The mechanical coupling devices or components shall be designed and manufactured such that in normal use and with correct maintenance and replacement of wearing parts they will continue to function satisfactorily and retain the characteristics prescribed by this Regulation.
- 4.5. All mechanical coupling devices or components shall be designed to have positive mechanical engagement and the closed position shall be locked at least once by further positive mechanical engagement unless further requirements are stated in Annex 5. Alternatively there may be two or more separate arrangements to ensure the integrity of the device but each arrangement shall be designed to have positive mechanical engagement and shall be tested individually to any requirements given in Annex 6. Positive mechanical engagement shall be as defined in paragraph 2.13.

Spring forces may be used only to close the device and to prevent the effects of vibration from causing component parts of the device to move to positions where it may open or disengage.

The failure or omission of any one single spring shall not allow the complete device to open or disengage.

Remote indication devices, when installed in the vehicle cab, shall be mounted within the driver's field of vision, and be clearly identified.

When installed on the side of the vehicle, the remote indication devices shall be permanently and clearly identified. The remote indication device shall be automatically activated and reset during every opening and closing of the coupling.

- 4.6. Every device or component shall be accompanied by installation and operating instructions giving sufficient information for any competent person to install it correctly on the vehicle and operate it properly - see also Annex 7. The instructions shall be in at least the language of the country in which it will be offered for sale. In the case of devices and components supplied for original equipment fitting by a vehicle manufacturer or bodybuilder, installation instructions may be dispensed with but the vehicle manufacturer or bodybuilder will be responsible for ensuring that the vehicle operator is supplied with the necessary instructions for correct operation of the coupling device or component.
- 4.7. Quick height-adjustable towing devices with no power assistance may not exceed an operating force of 40 daN.

5. Application for approval of a vehicle fitted with a mechanical coupling device or component

- 5.1. The application for approval of a vehicle type with regard to the fitting of a mechanical coupling device or component shall be submitted by the vehicle manufacturer or by his duly accredited representative.
- 5.2. It shall be accompanied by the following information to enable the type approval authority to complete the communication form given in Annex 2.
 - 5.2.1. Drawings which are sufficiently detailed to identify the device or component and which specify how it is to be fitted to the vehicle; the drawings shall show the position and space provided for the approval number and other marking as given in paragraph 7.;
 - 5.2.2. A detailed technical description of the device or component, specifying, in particular, the type and the materials used;
 - 5.2.3. A statement of the values of D, D_c, S, A_v and V as applicable and as defined in paragraph 2.10.;
 - 5.2.3.1. The characteristic values shall be at least equal to those applicable to the maximum permissible towing vehicle, trailer and combination masses.
 - 5.2.4. A vehicle, representative of the type to be approved and fitted with a mechanical coupling device, shall be submitted to the Type Approval Authority or Technical Service which may also request additional samples of the device or component;
 - 5.2.5. A vehicle not having all of the components appropriate to the type may be accepted provided that the applicant can show, to the satisfaction of the Type Approval Authority or Technical Service, that the absence of the components does not have any effect on the results of the inspection as far as the requirements of this Regulation are concerned.

6. General requirements for vehicles fitted with a mechanical coupling device or component

- 6.1. The mechanical coupling device or component fitted to the vehicle shall be approved in accordance with the requirements of paragraphs 3. and 4. and Annexes 5 and 6 to this Regulation.

- 6.2. The installation of the mechanical coupling device or component shall meet the requirements of Annex 7 to this Regulation.
- 6.3. Operating instructions shall be provided for use of the coupling device or component which shall contain any special instructions for operations which are different from those normally associated with the type of coupling device or component and instructions for coupling and uncoupling with different modes of operation, for example, at various angles between the towing and towed vehicles. Each vehicle shall be accompanied by these operating instructions which shall be at least in the language of the country in which it will be offered for sale.

7. Markings

- 7.1. Types of mechanical coupling devices and components submitted for approval shall bear a type plate with the trade name or mark of the manufacturer, supplier or applicant.
- 7.2. There shall be a sufficiently large space for application of the approval mark referred to in paragraph 8.5. and shown in Annex 3. This space shall be shown on the drawings referred to in paragraph 3.2.2.
- 7.3. Adjacent to the approval mark referred to in paragraphs 7.2. and 8.5., the mechanical coupling device or component shall be marked with the class of coupling, as defined in paragraph 2.6. and the relevant characteristic values as defined in paragraph 2.10. and shown in Annex 4 and the maximum design speed defined in 2.11. The position for these markings shall be shown on the drawings referred to in paragraph 3.2.2.
- 7.4. Where the mechanical coupling device or component is approved for alternative characteristic values within the same class of coupling or device, a maximum of two alternatives shall be marked on the device or component.
- 7.5. If the application of the mechanical coupling device or component is restricted in any way, for example, if the use of the device is limited to a certain speed, then that restriction shall be marked on the device or component.
- 7.6. All markings shall be permanent and legible when the device or component is installed on the vehicle.

8. Approval

- 8.1. If the sample(s) of a type of mechanical coupling device or component meets (meet) the requirements of this Regulation, approval shall be granted subject to the requirements of paragraph 10. being satisfactorily met.
- 8.2. An approval number shall be assigned to each type approved. Its first two digits (at present 00) shall indicate the series of amendments incorporating the most recent major technical amendments made to the Regulation at the time of issue of the approval. The same Contracting Party may not assign the same number to another type of device or component referred to in this Regulation.
- 8.3. Notice of approval or of extension, refusal or withdrawal of approval or of production definitely discontinued, relating to a type of mechanical coupling device or component approved pursuant to this Regulation, shall be communicated to the Parties to the 1958 Agreement applying this Regulation,

by means of a communication form conforming to the model in either Annex 1 or Annex 2 to this Regulation.

- 8.4. In addition to the mark prescribed in paragraph 7.1., there shall be affixed to every mechanical coupling device or component approved under this Regulation, in the space referred to in paragraph 7.2., an approval mark as described in paragraph 8.5.
- 8.5. The approval mark shall be an international mark comprising:
 - 8.5.1. A circle surrounding the letter "E" followed by the distinguishing number of the country which has granted approval;⁵
 - 8.5.2. The approval number prescribed in paragraph 8.2.;
 - 8.5.3. A capital letter D when tested according to Annex 6 paragraph 3.1.3 (dynamic endurance test) or
 - 8.5.4. a capital letter S when tested according to Annex 6 paragraph 3.3.3.2 (static test);
 - 8.5.5. A capital letter T for two-component testing;
 - 8.5.6. The approval mark and number shall be arranged as shown in the example in Annex 3.

9. Modifications of the mechanical coupling device or component, or of the vehicle and extension of approval

- 9.1. Any modification to the type of mechanical coupling device or component, or of the vehicle as defined in paragraph 2.9. shall be notified to the Type Approval Authority or Technical Service which granted the approval. The Type Approval Authority or Technical Service may then either:
 - 9.1.1. Consider that the modifications are unlikely to have any appreciable adverse effect and that in any case the device, component or vehicle still conforms to requirements; or
 - 9.1.2. Require a further test report.
- 9.2. Confirmation of, or refusal of approval, specifying the modification, shall be communicated by the procedure prescribed in paragraph 8.3. to the Contracting Parties applying this Regulation.
- 9.3. The Type Approval Authority or Technical Service issuing an extension of approval shall assign a series number for such an extension and shall inform the other Contracting Parties applying this Regulation by the procedure prescribed in paragraph 8.3.

⁵ The distinguishing numbers of the Contracting Parties to the 1958 Agreement are reproduced in Annex 3 to the Consolidated Resolution on the Construction of Vehicles (R.E.3), document ECE/TRANS/WP.29/78/Rev. 6, Annex 3-
www.unece.org/trans/main/wp29/wp29wgs/wp29gen/wp29resolutions.html.

10. Conformity of production procedures

The conformity of production procedures shall comply with those set out in the 1958 Agreement, Schedule 1 (E/ECE/TRANS/505/Rev.3), with the following requirements:

- 10.1. The holder of the approval shall ensure that results of the conformity of production tests are recorded and that the annexed documents remain available for a period determined in agreement with the Type Approval Authority or Technical Service. This period shall not exceed 10 years counted from the time when production is definitively discontinued.
- 10.2. The Type Approval Authority or Technical Service which has granted type approval may at any time verify the conformity control methods applied in each production facility. The normal frequency of these verifications shall be once every two years.

11. Penalties for non-conformity of production

- 11.1. The approval granted in respect of a type of mechanical coupling device or component pursuant to this Regulation may be withdrawn if the requirements are not complied with or if a device or component bearing the approval mark does not conform to the type approved.
- 11.2. If a Contracting Party to the Agreement applying this Regulation withdraws an approval it has previously granted, it shall forthwith so notify the other Contracting Parties applying this Regulation by means of a communication form conforming to the model in either Annex 1 or Annex 2 to this Regulation.

12. Production definitively discontinued

If the holder of the approval completely ceases to manufacture a type of mechanical coupling device or component approved in accordance with this Regulation, he shall so inform the Type Approval Authority or Technical Service which granted the approval. Upon receiving the relevant communication, that Type Approval Authority or Technical Service shall inform thereof the other Contracting Parties to the 1958 Agreement applying this Regulation by means of a communication form conforming to the model in either Annex 1 or Annex 2 to this Regulation.

13. Names and addresses of Technical Services responsible for conducting approval tests and of Type Approval Authorities

- 13.1. The Contracting Parties to the 1958 Agreement applying this Regulation shall communicate to the United Nations Secretariat the names and addresses of the Technical Services responsible for conducting approval tests and of the Type Approval Authorities which grant approval and to which forms certifying approval or extension or refusal or withdrawal of approval, or production definitively discontinued, issued in other countries, are to be sent.

Annex 1

Communication concerning devices and components

(Maximum format: A4 (210 x 297 mm))



issued by: Name of administration:

.....
.....
.....

Concerning:² Approval granted
Approval extended
Approval refused
Approval withdrawn
Production definitively discontinued

of a type of mechanical coupling technical unit or component pursuant to UN Regulation No. [xxx]

Approval No. Extension No.

1. Trade name or mark of the technical unit or component:
2. Manufacturer's name for the type of technical unit or component:
3. Manufacturer's name and address:
4. If applicable, name and address of the manufacturer's representative:
5. Alternative supplier's names or trademarks applied to the technical unit or component:
6. In case of a technical unit: type and make of the vehicle, where the technical unit is intended for.....
7. Name and address of company or body taking responsibility for the conformity of production:
8. Submitted for approval on:

¹ Distinguishing number of the country which has granted/extended/refused/withdrawn approval (see approval provisions in the Regulation).

² Strike out what does not apply.

9. Technical Service responsible for conducting approval tests:
10. Brief description:
 - 10.1. Type and class of technical unit or component:
 - 10.2. Characteristic values:
 - 10.2.1. Primary values:
D..... kN D_c..... kN S..... kg
Av.....tonnes v_{max}.....km/h V..... kN
Alternative values:
D..... kN D_c..... kN S..... kg
Av.....tonnes v_{max}.....km/h V..... kN
11. Instructions for the attachment of the coupling device or component type to the vehicle and photographs or drawings of the mounting points given by the vehicle manufacturer:
12. Information on the fitting of any special reinforcing brackets or plates or spacing components necessary for the attachment of the coupling device or component:
13. Date of test report:
14. Number of test report:
15. Approval mark position:
16. Reason(s) for extension of approval:
17. Approval granted/extended/refused/withdrawn:²
18. Place:
19. Date:
20. Signature:
21. The list of documents deposited with the Type Approval Authority which has granted approval is annexed to this communication and may be obtained on request:

Annex 2

Communication concerning vehicles

(Maximum format: A4 (210 x 297 mm))



issued by: Name of administration:

.....
.....
.....

Concerning:² Approval granted
Approval extended
Approval refused
Approval withdrawn
Production definitively discontinued

of a vehicle type with regard to the fitting of a mechanical coupling device or component pursuant to UN Regulation No. [xxx]

Approval No..... Extension No

1. Trade name or mark of vehicle:
2. Vehicle type:
3. Manufacturer's name and address:
.....
4. If applicable, name and address of the manufacturer's representative:
.....
5. Vehicle category, for example, T, R:³.....
6. Maximum permissible vehicle mass:kg
Distribution of maximum permissible vehicle mass between the axles:
.....
Maximum permissible towable trailer mass:kg
Maximum permissible static mass on coupling point:kg

¹ Distinguishing number of the country which has granted/extended/refused/withdrawn approval (see approval provisions in the Regulation).

² Strike out what does not apply.

³ As defined in the Consolidated Resolution on the Construction of Vehicles (R.E.3.), document ECE/TRANS/WP.29/78/Rev.6, para. 2 - www.unece.org/trans/main/wp29/wp29wgs/wp29gen/wp29resolutions.html.

Maximum mass of the vehicle, with bodywork, in running order, including coolant, oils, fuel, tools and spare wheel (if supplied) but not including driver:

..... kg

7. Required characteristic values

D..... kN D_c..... kN S..... kg

Av..... tonnes v_{max}.....km/h V..... kN

8. Instructions for the attachment of the coupling device or component type to the vehicle and photographs or drawings of the mounting points:

.....

9. Information on the fitting of any special reinforcing brackets or plates or spacing components necessary for the attachment of the coupling device or component:

.....

10. Trade name or mark of the mechanical coupling device or component and the approval number:

.....

11. Class of coupling device or component:

12. Submitted for approval on:

13. Technical service responsible for conducting approval tests:

.....

14. Date of test report:

15. Number of test report:

16. Approval mark position:

17. Reason(s) for extension of approval:

18. Approval granted/extended/refused/withdrawn:²

19. Place:

20. Date:

21. Signature:

22. The list of documents deposited with the Type Approval Authority which has granted approval is annexed to this communication and may be obtained on request.

.....

Annex 3

Example of an arrangement of the approval mark

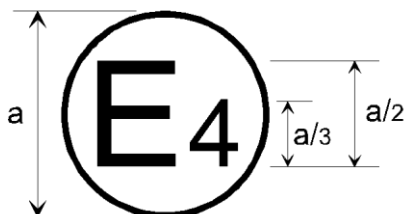

[XXX]R - 002405S \updownarrow a/3

a = 8 mm minimum

The mechanical coupling device or component or vehicle bearing the approval mark shown above is a device or component approved in the Netherlands (E 4), under approval number 2405, meeting the requirements of the 00 series of amendments to this Regulation and was tested statically (S).

Note: The approval number and additional symbols shall be placed close to the circle and either above or below the letter "E", or to the right or left of that letter. The digits of the approval number shall be on the same side of the letter "E" and face in the same direction. The use of Roman numerals as approval numbers should be avoided so as to prevent any confusion with other symbols.

Annex 4

Examples of arrangements of marking of the characteristic values

1. All mechanical coupling devices or components shall be marked with the class of the device or component. In addition there shall be marking to indicate the capacity in terms of characteristic values as defined in paragraph 2.10. of this Regulation.
 - 1.1. The height of all letters and numbers shall be not less than those of the approval number, that is $a/3$ where a is 8 mm minimum.
 - 1.2. The characteristic values applicable to each device or component which are to be marked are as shown in the Table below - see also paragraph 7.3. of this Regulation:

Table 1
Relevant characteristics values to be marked on coupling devices or components

Description of mechanical coupling device or component	Relevant characteristic values to be marked						
	Class	D	D _c	S	V	V _{max}	T**
Coupling balls 80 (Class a)	★	★	★	★	★	★	-
Coupling head (Class b)	★	★	★	★	★	★	-
Clevis-type couplings (Class c or q)	★	★	★	★	★	★	★
Hook-type couplings (Class g)	★	★	★	★	★	★	-
Tractor drawbars (Class i)	★	★	★	★	★	★	★
Towing frames (Class f)	★	★	★	★	★	★	-
Piton-type couplings (Class h)	★	★	★	★	★	★	-
Drawbar eyes (Class d or r)	★	★	★	★	★	★	★
Drawbars (Class e)*	★	★	★	★	★	★	-

* Hinged drawbars shall in addition have the Av-value marked on the type plate, but no S- or V-value

** Towable mass when tested according to Annex 6 paragraph 3.3.3.2.-(static test) (should be defined in the definitions, if needed)

Examples: a80 D130 D_c90 S2000 would identify a standard coupling ball 80 of Class a80 with a maximum D value of 130 kN, a maximum permitted D_c value of 90 kN and a maximum permitted static vertical imposed load of 2,000 kg.

Annex 5

Requirements for mechanical coupling devices or components for vehicles of categories T, R and S

1. Coupling balls 80 and keeper plates (Class a80)
 - 1.1. General requirements for coupling balls 80
 - 1.1.1. All coupling balls 80 and keeper plates shall be designed such that the coupling balls satisfy the tests prescribed in paragraph 3.1 of Annex 6 and keeper plates satisfy the tests prescribed in paragraph 3.3.5 of Annex 6.
 - 1.1.2. Coupling balls 80 of class a shall conform to Figure 1 in external shape and external dimensions. The position of the keeper plate is shown in Figure 2.

Figure 1
Coupling ball of Class a (all dimensions in mm)

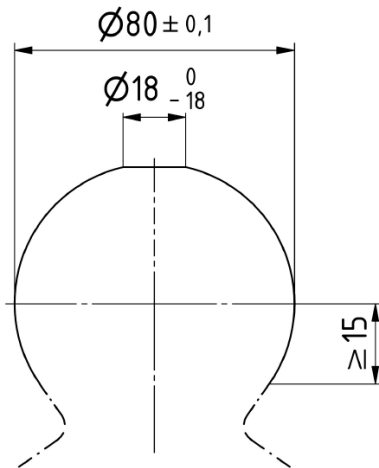
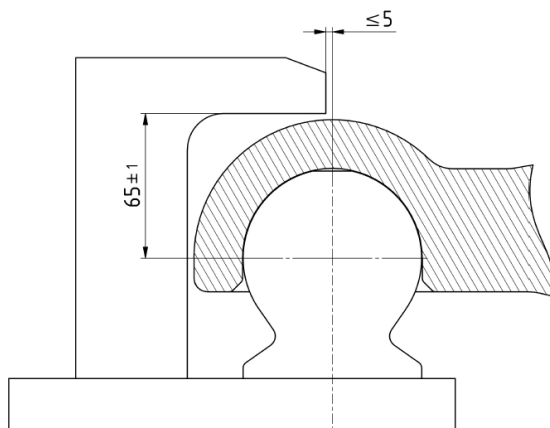
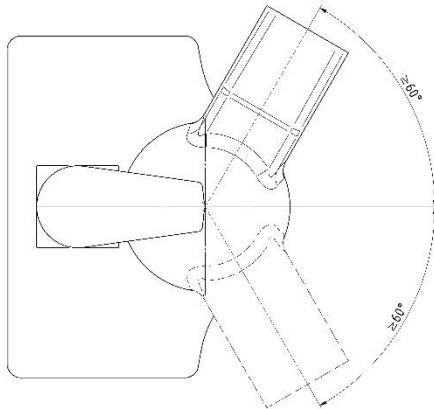

Figure 2
Keeper plate dimensions (all dimensions in mm)



- 1.1.3. The coupling balls 80 shall have at least the following angles of articulation, which do not have to be reached simultaneously:

Figure 3
Angles of articulation



Vertical axis: $\pm 60^\circ$ min.

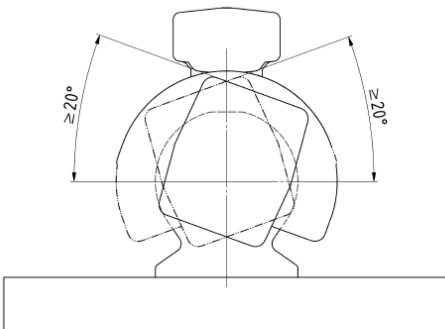

Longitudinal axis: $\pm 20^\circ$ min.

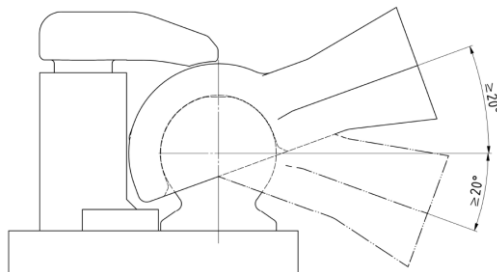

Transverse axis: $\pm 20^\circ$ min.

2. Coupling head 80 (Class b80)
 - 2.1. General requirements for coupling head 80
 - 2.1.1. All coupling head 80 shall be designed so that they are able to satisfy the tests given in paragraph 3.2 of Annex 6.
 - 2.1.2. Coupling head 80 of class b shall conform to Figure 4 in external shape and external dimensions.

Figure 4
Dimensions of coupling head 80 of Class b (all dimensions in mm)

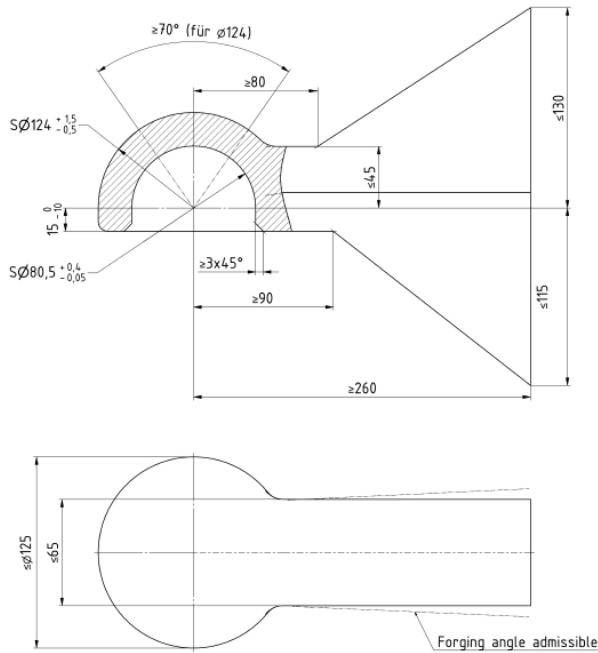

3. Clevis-type drawbar couplings (Class c40)
 - 3.1. General requirements for clevis-type drawbar couplings
 - 3.1.1. All clevis-type drawbar couplings shall be designed so that they satisfy the tests prescribed in paragraph 3.3.1 of Annex 6 and locking devices so that they satisfy the tests prescribed in paragraph 3.3.1.3 of Annex 6.
 - 3.1.2. Clevis-type drawbar couplings of class c shall conform to Figures 5, 6 and 7 in external shape and external dimensions. For all classes, the maximum height of the jaw shall be constant over at least half the width of the jaw.
 - 3.1.3. Requirements:

In the case of automatic couplings, the closed and locked position shall be clearly and conspicuously indicated externally after coupling by at least one control indicator.
 - 3.1.4. Clevis-type drawbar couplings shall have the following angles of articulation (see also Figures 5 and 6):
 - (a) Vertical axis: $\pm 70^\circ$ min.
 - (b) Transverse axis: $\pm 20^\circ$ min.
 - (c) Longitudinal axis: $\pm 20^\circ$ min.
 - 3.1.5. The jaw shall permit the drawbar rings to swivel axially at least 90° to the right or left around the longitudinal axis of the coupling with a fixed braking momentum of between 30 and 150 Nm.

Figure 5
Automatic coupling device with bulged pin (left) and automatic trailer coupling with cylindrical pin (right) (all dimensions in mm)

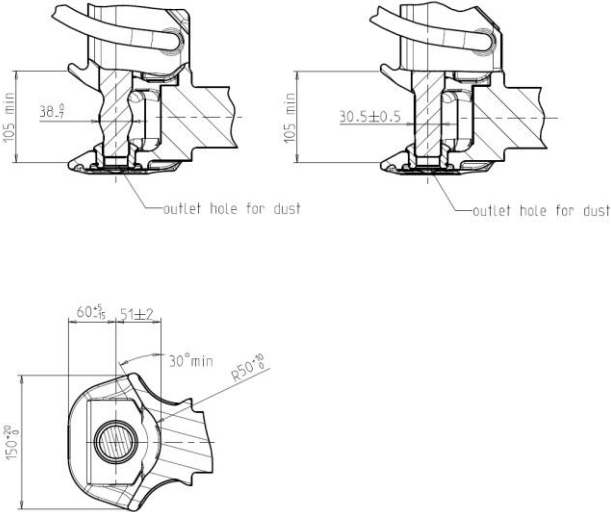
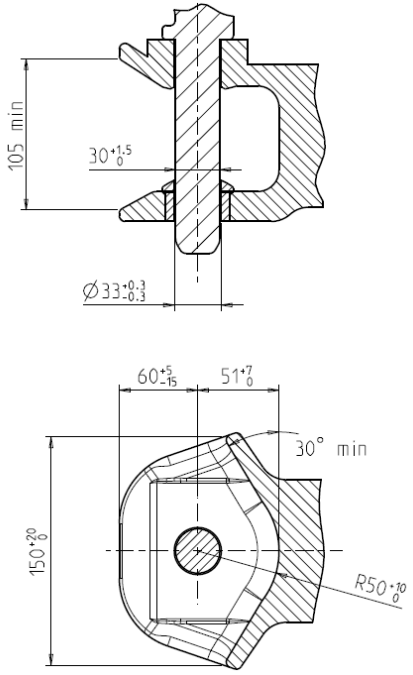

Figure 6
Non-automatic trailer coupling with cylindrical pin (all dimensions in mm)



4. Drawbar eyes (Class d40-1 and d40-2)

4.1. Drawbar eyes d40-1

4.1.1 General requirements for drawbar eyes d40-1

All drawbar eyes of class d40-1 shall be designed so that they are able to satisfy the tests given in paragraph 3.4 of Annex 6. Drawbar eyes d40-1 may be equipped with or without socket.

Drawbar eyes shall conform to Figure 7 in the external shape and external dimensions of the ring.

Figure 7

Principal dimensions of standard drawbar eyes d40-1 (all dimensions in mm)

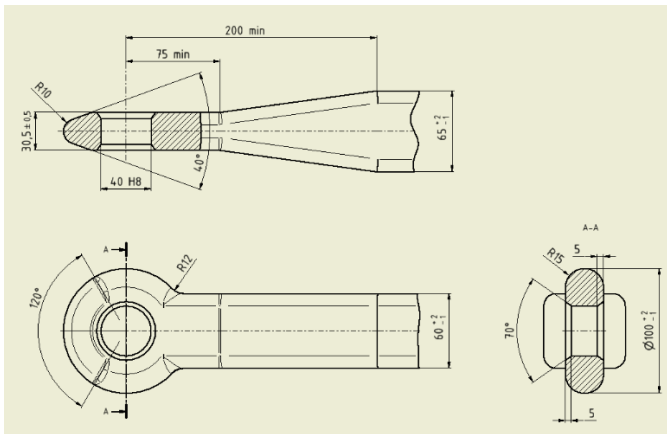

4.2. Drawbar eyes d40-2

4.2.1. General requirements for drawbar eyes d40-2

All drawbar eyes of class d40-2 shall be designed so that they are able to satisfy the tests given in Annex 6.

Drawbar eyes shall conform to Figure 8 in the external shape and external dimensions of the ring.

Figure 8

Principal dimensions of standard coupling ring d40-2

Dimensions in millimetres

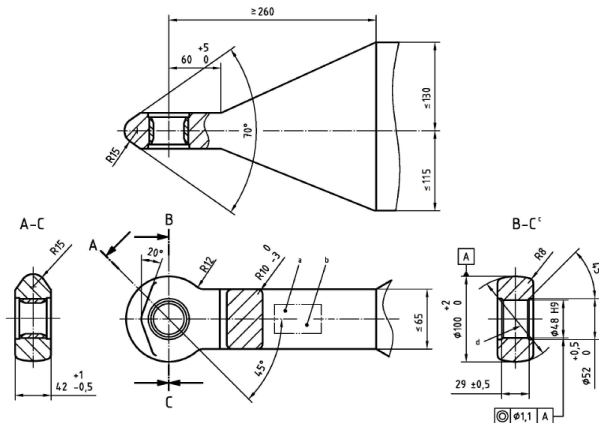

4.3. Toroidal drawbar eye (Class d50-1 and d50-2)

4.3.1. General requirements

All drawbar eyes of class d50 shall be designed so that they are able to satisfy the tests given in Annex 6.

Drawbar eyes of class d50 shall conform to Figure 9 in external shape and external dimensions.

Figure 9

Principal dimensions of toroidal drawbar eye of class d50 (all dimensions in mm)

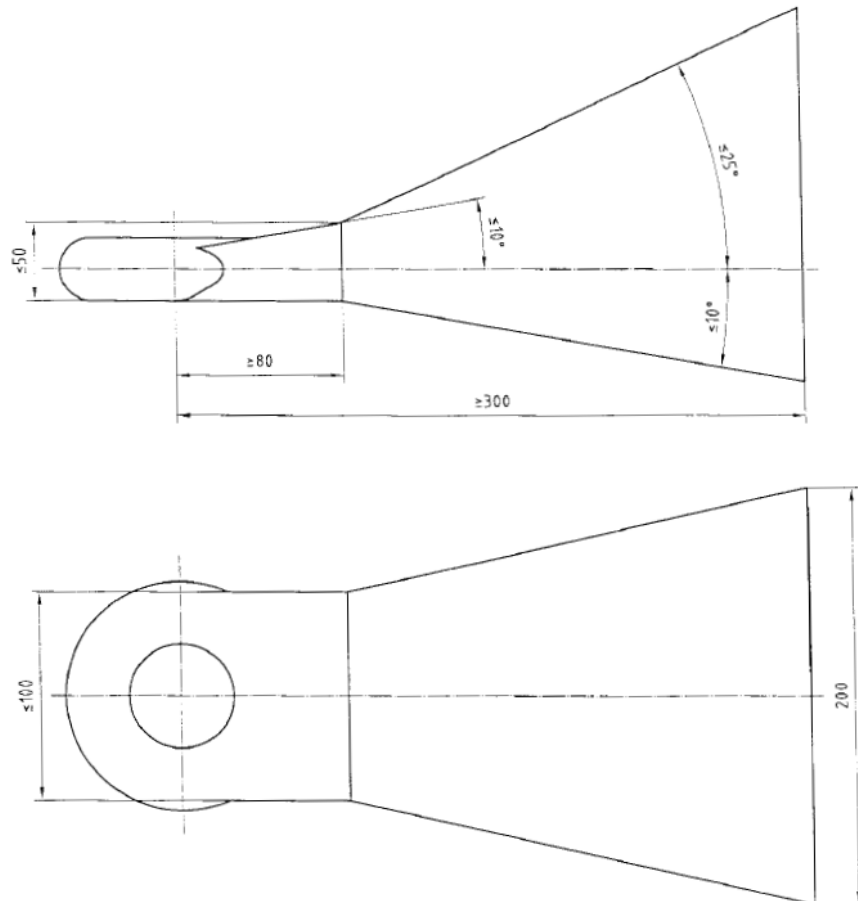

4.3.2. In addition, toroidal drawbar eye of class d50-1 shall have the dimensions according to Figure 10 and toroidal drawbar eye of class d50-2 shall have the dimensions according to Figure 11.

Figure 10
Dimensions of toroidal drawbar eye of class d50-1 (all dimensions in mm)

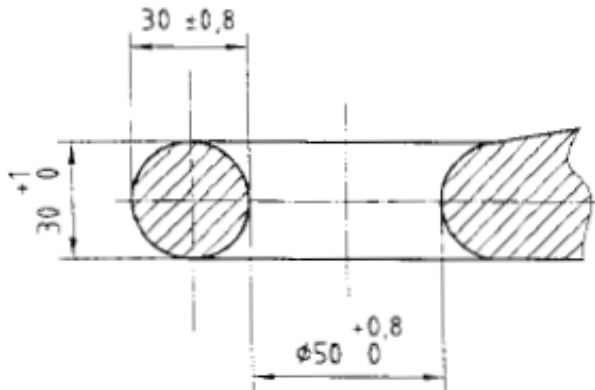
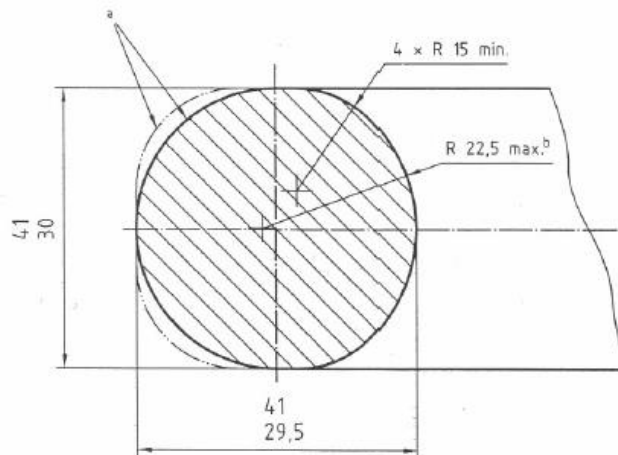
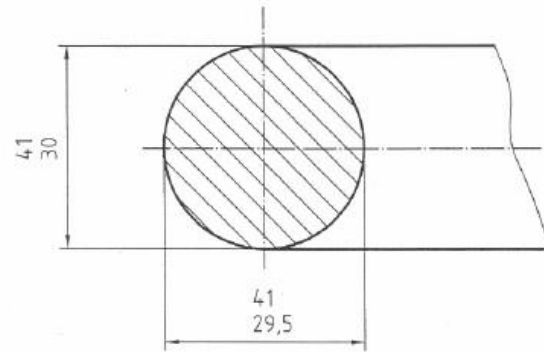

Figure 11
Dimensions of toroidal drawbar eye of class d50-2 (all dimensions in mm)



- ^a Alternative outer contour: outer radius 22,5 max. and 15 min. blend radius top and bottom, or min. top and bottom blend radius to flat outer surface.
- ^b Internal contour.

5. Drawbars (Class e)
 - 5.1. Drawbars of class e shall satisfy the tests given in paragraph 3.7 of Annex 6.
 - 5.2. In order to provide a connection to the towing vehicle, the drawbars can be fitted with either coupling head or drawbar eyes of classes b, d or s. coupling head and drawbar eyes can be attached by screwing, bolting or welding.
 - 5.3. Height adjusting devices for hinged drawbars
 - 5.3.1. Hinged drawbars shall be fitted with devices for adjusting the drawbar to the height of the coupling device or jaw. These devices shall be designed so that the drawbar can be adjusted by one person without tools or any other aids.
 - 5.3.2. Height adjusting devices shall be able to adjust the drawbar eyes or coupling head 80 from the horizontal above the ground at least 300 mm upwards and downwards. Within this range the drawbar shall be adjustable steplessly, or in maximum steps of 50 mm measured at the coupling ring or coupling head.
 - 5.3.3. Height adjusting devices shall not interfere with the easy movement of the drawbar after coupling.
 - 5.3.4. The height adjusting devices shall not interfere with the action of any inertia, overrun type, brake.
 - 5.4. In the case of drawbars combined with inertia, overrun, brakes, the distance between the centre of the drawbar eye and the end of the free shank of the drawbar eye shall not be less than 200 mm in the brake application position. With the shank of the drawbar eye fully inserted the distance shall not be less than 150 mm.
 - 5.5. Drawbars for use on rigid drawbar trailers shall possess at least half the moment of resistance against lateral forces as against vertical forces.
6. Towing frames and rail plates (Class f)

Figure 12

Example of a towing frame of class f

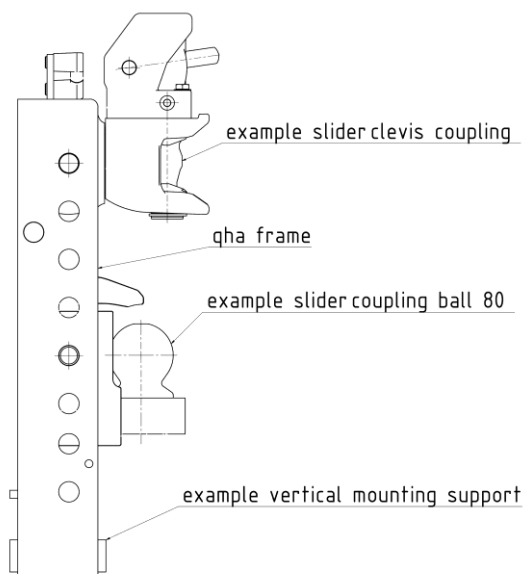

- 6.1. Towing frames of class f shall satisfy the tests given in paragraph 3.6 of Annex 6.
- 6.2. If the towing frames are intended to be mounted to specified vehicle types the fixing points and the coupling shall be in conformity with the vehicle- or the transmission manufacturers provisions.
- 6.3. Towing frames can be designed as quick height-adjustable (qha), pin height-adjustable (pha) frame or as frame without height adjustment. The mostly used types are qha-frames for qha-sliders, so called ladder frames as shown in Figure 12.
7. Hitch hooks and keeper plates (Class g)
- 7.1. General requirements for hitch hooks
- All hitch hooks of class g and keeper plates shall be designed such that hitch hooks satisfy the tests given in Annex 6 and keeper plates satisfy the tests given in Annex 6.
- Hitch hooks of class g shall conform to Figure 13 in external shape and external dimensions. The position of the keeper plate is shown in Figure 14.
- The hitch hook shall permit angles of articulation in accordance with 1.1.3.

Figure 13
Principal dimensions of hitch hook (all dimensions in mm)

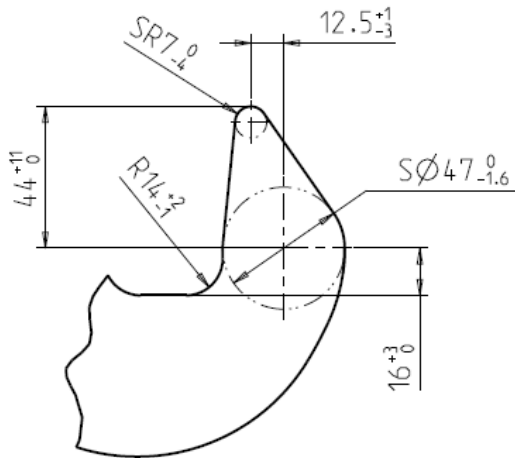
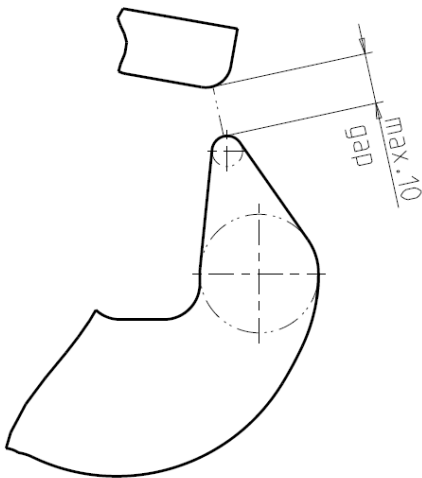

Figure 14
Position of the keeper plate (all dimensions in mm)



- 8. Piton-type couplings and keeper plates (Class h)
- 8.1. General requirements for piton-type couplings

All piton-type couplings of class h and keeper plates shall be designed such that piton-type couplings satisfy the tests given in Annex 6 and keeper plates satisfy the tests given in Annex 6.

Piton-type couplings of class h shall conform to Figure 15 in external shape and external dimensions. The position of the keeper plate is shown in Figure 16.

The piton-type coupling shall permit angles of articulation in accordance with 1.1.3.

Figure 15
Principal dimensions of piton-type coupling (all dimensions in mm)

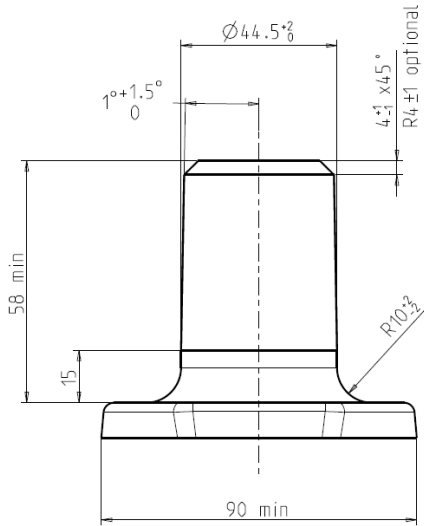
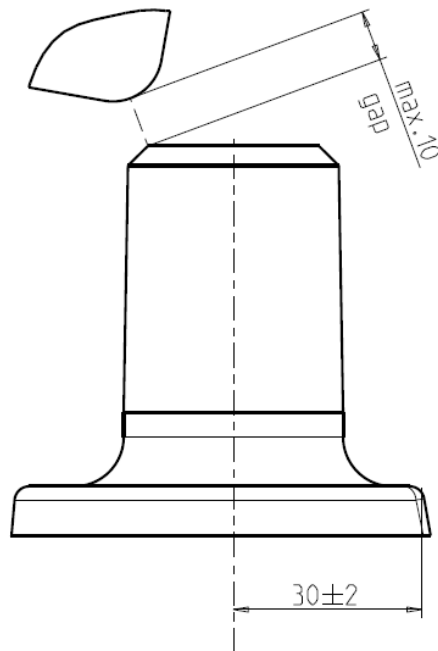

Figure 16
Position of the keeper plate (all dimensions in mm)



9. Tractor drawbar couplings non-swivel around longitudinal axis (Class i)
- 9.1. Tractor drawbar couplings shall have the following angles of articulation (see also Figure 17)
 - a) Vertical axis: $\pm 90^\circ$ min
 - b) Transverse axis: $\pm 20^\circ$ min. ($\pm 15^\circ$ for cat.4 and 5)
 - c) Longitudinal axis: $\pm 20^\circ$ min. ($\pm 15^\circ$ for cat.4 and 5)These angles of articulation do not have to be reached simultaneously.
- 9.2. The coupling unit shall be tested as in 3.3.3 of Annex 6.
- 9.3. The drawbar coupling non-swivel clevis unit shall be provided with a device to prevent unintentional uncoupling.
- 9.4. Drawbar and clevis of Class i shall conform to Figure 17 and Table 2.

Figure 17
Tractor drawbar and clevis dimensions (class i) (all dimensions in mm)

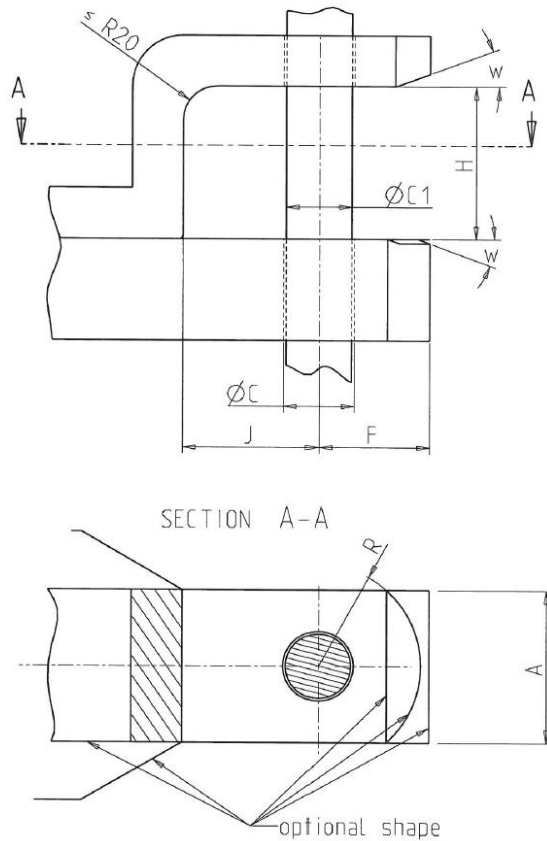

Table 2
Tractor drawbar and clevis- Dimension values

Dimensions in millimetres

Dimension		Drawbar category					
		0	1	2	3	4	5
Drawbar width A ^a	max.	60	67	90	100	130	160
Drawbar thickness B	max.	20	36	52	57	64	80
Pin hole diameter C	+1.00/-0.25	20	33	33	41	52.5	72.5
Pin diameter C1	+1.00/-1.50	18.5	31	31	39	51	71
F	max.	30	45	45	55	70	80
G ^b	min.	140	210	210	210	210	210
Height H	min.	50	70	70	90	90	100
Throat depth J	min.	50	70	80	80	90	110
End radius of drawbar and clevis R ^c	max.	30	45	50	60	80	80
W ^c	min.	20°	20°	20°	20°	15°	15°

^a The drawbar pin handle, retention devices of clevis may extend beyond width A but must not interfere with the implement articulation angles specified in clause 10.

^b G is the distance over which the specified dimensions A and B shall be maintained.

^c The profile shown in Figure 17 represents the maximum envelope for the drawbar and clevis. The radius R and the angle W may differ from the values given so long as the maximum envelope is not exceeded.

10. Drawbar eyes which are fitted to trailer drawbars for connecting to a tractor drawbar (Class j)
- 10.1. The coupling unit shall be tested as in 3.3.3 of Annex 6.
- 10.2. Drawbar eyes of Class j shall conform to Figure 18 and Table 3.

Figure 18
Hitch ring of implement (Class j)

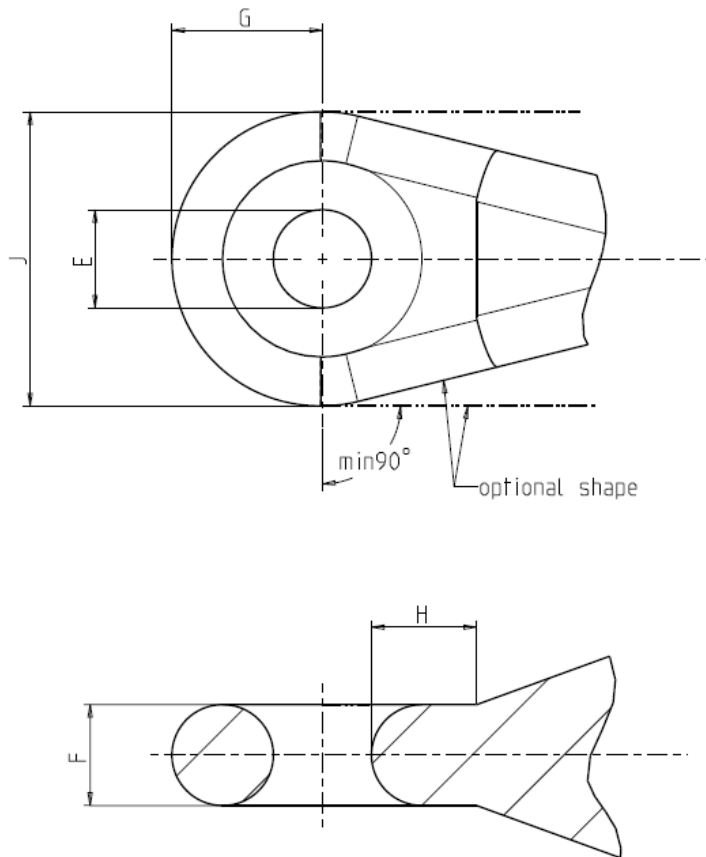

Dimensions in millimetres

Table 3
Hitch ring specifications (Class j)

Dimension		Drawbar category					
		0	1	2	3	4	5
Hole E ^a	min.	23	38	38	47	56	78
Thickness F	max.	30	36	38	46	50	60
Distance G	max.	40	55	55	75	85	100
Distance H	min.	35	40	50	50	65	80
Width J	max.	85	107	115	140	160	190
Radius M		As required to provide adequate articulation between the tractor and the implement $M_{max} = F/2$					
Pin diameter	min.	In accordance with Table 2					

^a For special applications hole E can be an elongated hole

11. Clevis-type drawbar coupling non-swivel around longitudinal axis (Class q)
- 11.1. The coupling unit shape shall allow the swivel hitch ring the following minimum angles:
- ±60° in the horizontal plane (yaw)
 - ±20° in the vertical plane (pitch)
 - ±20° around its longitudinal axis (roll)
- The non-swivel clevis coupling unit shall be provided with a device to prevent unintentional uncoupling.
- 11.2. The coupling unit shall be tested as in 3.3.3 of Annex 6.
- 11.3. Clevis type drawbar Class q shall conform to Figure 19 and Table 4.

Figure 19

Clevis type drawbar (Class q)

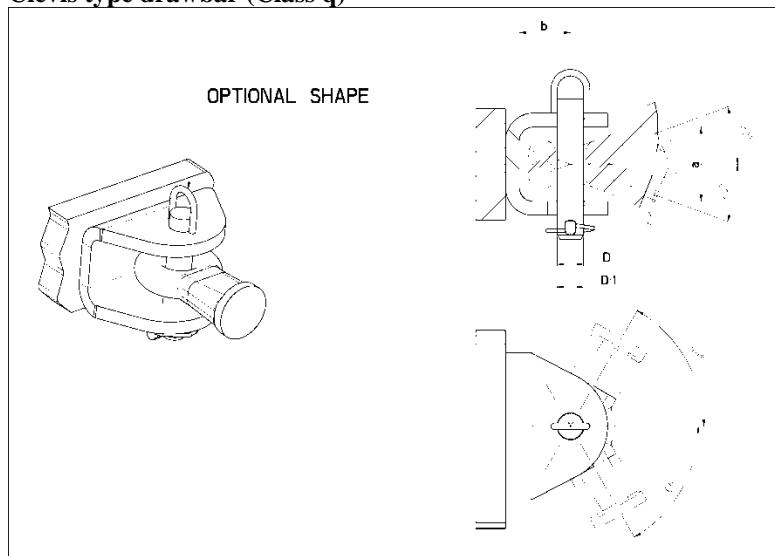

Table 4

Shapes and dimensions of trailer or implement clevis coupling (Class q)

Shape	Dimension mm		
	D ±0,5	a min.	b min.
w	18	50	40
x	28	70	55
y	43	100	80
z	50	110	95

12. Drawbar eye, swivel around longitudinal axis and fitted to the drawbar of trailers for connection with non swivel clevis type couplings (Class r)

- 12.1. The coupling unit shall be tested as in 3.3.3 of Annex 6.
- 12.2. Drawbar Eyes Class r shall conform to Figure 20 and Table 5.

Figure 20
Hitch ring dimensions shall be as shown (class r)

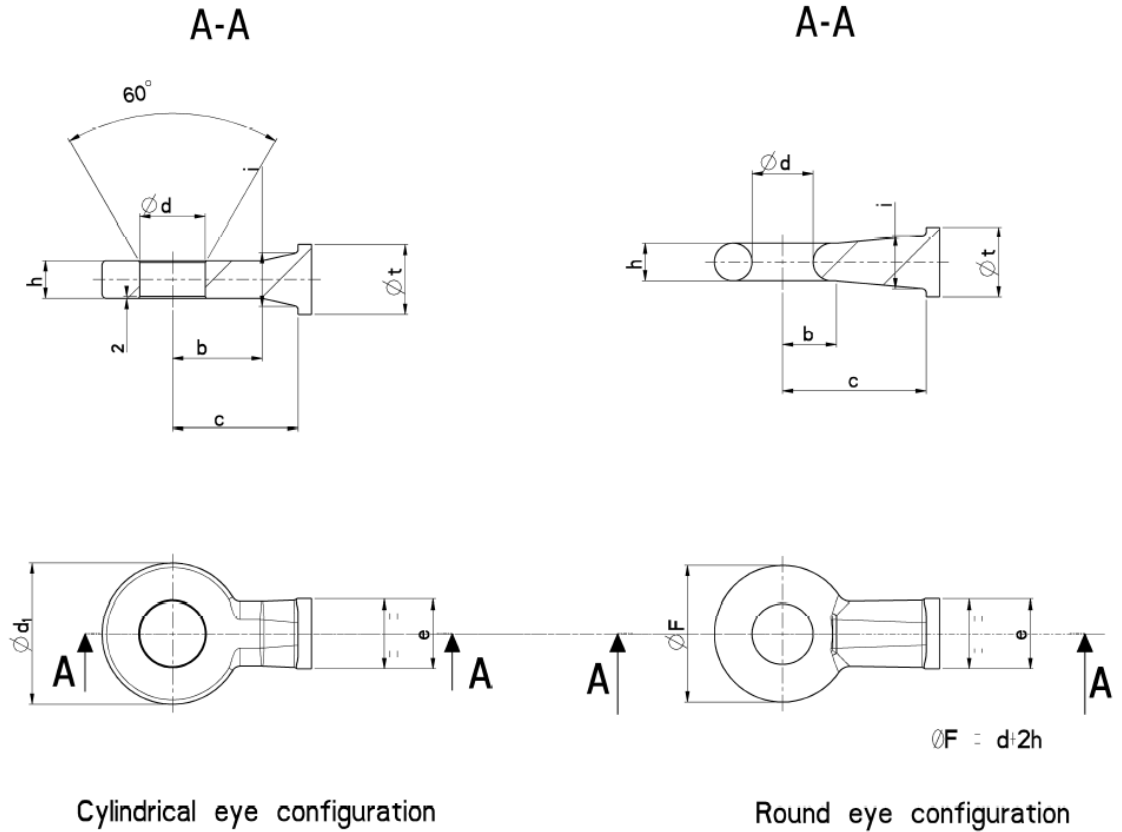

Table 5
Shapes and dimensions (Class r)

Shape	Coupling ring mm														
	Cylindrical eye configuration								Round eye configuration						
	<i>d</i>	<i>b</i>	<i>c</i>	<i>e</i>	<i>i</i>	<i>h</i>	<i>d</i> ₁	<i>t</i>	<i>d</i>	<i>b</i>	<i>c</i>	<i>e</i>	<i>i</i>	<i>t</i>	<i>h</i>
±0,5	min.	min.	max.	max.	±1	±3	min.	±0,5	min.	min.	max.	max.	min.	±1	
W	28	50	80	30	30	20	70	44	22	40	80	30	30	44	20
X	45	70	100	60	40	32	105	63	35	50	100	60	40	53	30
Y	62	90	120		55	40	132	73	50	55	140		55	73	35
Z	73	100	140	75	60	42	157	78	68	60	160	75	60	78	42

13. Coupling devices (Class s)
For coupling devices of class s and p, the relevant requirements in Annexes 5 and 6 for the closest standard or non-standard device or component shall be used.
14. Assignment of mechanical coupling devices of towing vehicles or self-propelled machines and towed vehicles
The assignment of mechanical coupling devices of towing vehicles or self-propelled machines and towed vehicles shall conform to Table 6.

Table 6
Assignment of mechanical coupling devices of towing vehicles or self-propelled machines and towed vehicles

<i>Coupling device on the towing vehicle</i>	<i>Coupling device on the towed vehicle</i>
Class a80	Class b80
Class c40	Class d40-1, d40-2
Class g	Class d50-1, d50-2
Class h	Class d50-2
Class i	Class j
Class q	Class r

15. Remote operated and/or automatic coupling
If the coupling is remote operated or automatic there must always be a remote indication visible to the operator to indicate that coupling has been effected and that the locking devices have engaged.
The remote indication shall be in the vehicle cab if the coupling is achieved without leaving the vehicle cab.

Annex 6

Testing of mechanical coupling devices or components for vehicles of categories T, R and S

1. General testing requirements
 - 1.1. Samples of coupling devices shall be tested for both strength and function. With coupling devices the strength shall be verified by a dynamic test. The strength of the mechanical coupling shall be established by alternating traction on a test bed. Should the design of the mechanical coupling (e.g. excessive play, towing hook) make it impossible to carry out the test with an alternating test load, the test load may also be applied on a rising basis in the direction of traction or pressure, whichever is the greater. In certain cases additional static tests may be necessary. Instead of the dynamic test, mechanical couplings of classes i, q and r intended to be mounted to agricultural vehicles with a maximum design speed not exceeding 40 km/h may be tested according to 3.3.3.2 of this Annex (static test). Mechanical couplings of all classes intended to be mounted to agricultural vehicles with a maximum design speed exceeding 60 km/h shall be tested in accordance with Annex 6 of Regulation 55.01. In addition, the type approval authority or technical service may waive a dynamic or static test if the simple design of a component makes a theoretical check possible in case of coupling classes d, e, f, i, j and class s similar to this coupling classes. Theoretical checks may also be carried out to determine worst case conditions. In all cases, theoretical checks shall ensure the same quality of results as with dynamic or static testing. In cases of doubt it is the results of physical testing that are overriding.
 - 1.2. The dynamic test shall be performed with approximately sinusoidal load (alternating and/or pulsating) with a number of stress cycles appropriate to the material. No cracks or fractures shall be allowed which affects the functioning of the coupling device.
 - 1.3. Only slight permanent deformation is permitted with the static tests prescribed. Unless stated otherwise the permanent (plastic) deformation after releasing shall not be more than 10 per cent of the maximum deformation measured during the test.
 - 1.4. The loading assumptions in the dynamic tests are based on the horizontal force component in the longitudinal axis of the vehicle and the vertical force component. Horizontal force components transverse to the longitudinal axis of the vehicle, and moments, are not taken into account provided they are of only minor significance.

If the design of the coupling device or its attachment to the vehicle or the attachment of additional systems (such as equipment drives, force compensators, positive steering systems, etc.) generates additional forces or moments, these shall be taken into account during the homologation procedure. Additional tests may also be required by the type approval authority or technical service.

The horizontal force component in the longitudinal axis of the vehicle is represented by a theoretically determined reference force, the D or Dc

value. The vertical force component, where applicable, is represented by the static vertical bearing load, S, at the point of coupling and the assumed vertical force component, V.

- 1.5. The characteristic values D, D_c, S, A_v and v_{max}, on which the tests are based and which are defined in paragraph 2.10 of this Regulation, shall be taken from the manufacturer's information given in the application for type approval – see communication form shown in Annex 1 and 2.
- 1.6. Any positive locking device, which is retained in position by spring force, shall remain in its secured position when subjected to a force applied in the least favourable direction and equivalent to three times the mass of the locking mechanism.
- 1.7. Loading assumptions

Dynamic pulsating endurance test with resultant test force:

$$F_{res} = \sqrt{F_h^2 + F_v^2} \text{ (kN)}$$

$$\alpha = \arctan \frac{F_v}{F_h}$$

within the range for tensile or compressive pulsating stresses (whichever is the greater)

Where

Horizontal load (kN):

$$F_h = 1.0 \cdot D_c$$

$$F_h = 1.0 \cdot D \text{ for full trailers}$$

Vertical load (kN)

$$F_s = g \cdot S + 0.3 \cdot V$$

2. Test procedures
 - 2.1. For the dynamic tests and static tests, the sample shall be placed in a suitable rig with a means of force application, such that it is not subjected to any additional forces or moments apart from the specified test force. In the case of alternating tests, the direction of force application shall not deviate by more than $\pm 1^\circ$ from the specified direction. In the case of pulsating and static tests, the angle shall be set for the maximum test force. This will normally require a joint at the point of force application (for example at the point of coupling) and a second joint a given distance away.
 - 2.2. The test frequency shall not exceed 35 Hz. The selected frequency shall be well separated from resonance frequencies of the test set up including the tested device. With asynchronous testing the frequencies of the two force components shall be between approximately one per cent and a maximum of three per cent apart. For coupling devices made from steel the number of stress cycles is 2×10^6 . For devices made from materials other than steel a higher number of cycles may be necessary. The dye-penetration method of crack testing or an equivalent method shall be used to determine any cracking during test.

- 2.3. With pulsating tests, the test force varies between the maximum test force and a minimum test force, which may not be greater than 5 per cent of the maximum test force unless otherwise stated in the specific testing procedure.
- 2.4. With static tests the test force shall be applied smoothly and quickly and be maintained for at least 60 seconds.
- 2.5. The coupling devices or components on test should normally be mounted as rigidly as possible on a test rig in the position in which they will be used on the vehicle. The fixing devices should be those specified by the manufacturer or applicant and should be those intended for the attachment of the coupling device or component to the vehicle and/or shall have identical mechanical characteristics.
- 2.6. Coupling devices or components shall be tested in the form used on the road. However, at the discretion of the manufacturer, and in agreement with the technical service, flexible components may be clamped if this is necessary for the test procedure and if this will not have any unrealistic influence on the test result.

Flexible components which are overheated during these accelerated test procedures may be replaced during the test. The test loads may be applied by means of special slack-free devices.
3. Specific testing requirements
 - 3.1. Coupling balls 80 (Class a)
 - 3.1.1. The basic test is a dynamic pulsating endurance test with resultant test force. Alternatively, a two-component synchronous dynamic endurance test is also permissible. The test sample comprises the coupling ball and the mountings necessary for attaching the assembly to the vehicle. The coupling ball shall be rigidly mounted to a test rig, capable of producing an alternating or pulsating force, in the actual position in which it is intended for use.
 - 3.1.2. A suitable Coupling head 80 shall be used as a means of force application. The sample shall be mounted on the test rig with the coupling elements applied for and arranged such that its relative position corresponds to that of the intended use. The sample shall not be subjected to any additional forces or moments apart from the test force. The test force shall be applied along a line of action through the point of coupling, directed at a resultant angle derived from the horizontal and vertical loading assumptions.
 - 3.1.3. Loading assumptions
As in paragraph 1.7. of this annex.
 - 3.2. Coupling head 80 (Class b)
 - 3.2.1. The basic test is a dynamic endurance test in which an alternating or pulsating test force is applied. Alternatively, a two-component synchronous dynamic endurance test is also permissible.
 - 3.2.2. The dynamic test shall be performed using a separate assembly with a coupling ball 80 of an equivalent or higher strength.

The sample shall be mounted on the test rig with the coupling elements applied for and arranged such that its relative position corresponds to that of the intended use.

The sample shall not be subjected to any additional forces or moments apart from the test force.

The test force shall be applied along a line of action through the point of coupling, directed at a resultant angle derived from the horizontal and vertical loading assumptions.

3.2.3. Loading assumptions

As in paragraph 1.7. of this annex.

3.3. Drawbar couplings

3.3.1. Clevis-type couplings (Class c)

A dynamic endurance test shall be carried out on a sample. The coupling device shall be equipped with all the fixings needed to attach it to the vehicle.

3.3.1.1. For rigid drawbar trailers

Dynamic pulsating endurance test within the range for pulsating tensile stresses with resultant test force (direction of pull rearwards and down)

As in paragraph 1.7. of this annex.

3.3.1.2. Clevis-type couplings on trailers

Loading assumptions taking into account the D value

$$D = g \cdot \frac{R_1 \cdot R_2}{R_1 + R_2}$$

is used.

R_1 and R_2 as specified by the manufacturer ($R_2 \cdot R_1$). Dynamic endurance tests as in paragraph 3.3.1.1. of this annex.

3.3.1.3. Static tests on locking device for coupling pin

With clevis-type couplings with non-cylindrical pins, it is also necessary to test the closure and any locking devices by means of a static force of $0.25 \cdot D$ acting in the direction of opening.

A test force of $0.1 \cdot D$ is sufficient in the case of cylindrical coupling pins.

This force shall be raised to the above value smoothly and quickly and be maintained for 10 seconds.

The test shall not cause the closure to open and it shall not cause any damage.

3.3.2. Hitch hooks (Class g)

As in paragraph 3.3.1. of this annex.

3.3.3. Tractor drawbars (Class i)

3.3.3.1. Either as in paragraph 3.3.1. or a static test instead of the dynamic test as described in paragraph 3.3.3.2. if the drawbar is intended to be mounted

to agricultural vehicles with a maximum design speed not exceeding 40 km/h.

3.3.3.2. Static Test Method

3.3.3.2.1. Test specifications

3.3.3.2.1.1. General

Subject to a check on its construction characteristics, the mechanical coupling shall undergo static tests in accordance with the requirements of paragraphs 3.3.3.2.1.2, 3.3.3.2.1.3 and 3.3.3.2.1.4.

3.3.3.2.1.2. Test preparation

The tests shall be carried out on a special machine, with the mechanical coupling and any structure coupling it to the body of the tractor attached to a rigid structure by means of the same components used to mount it on the tractor.

3.3.3.2.1.3. Test instruments

The instruments used to record loads applied and movements shall have the following degree of accuracy:

- (a) Loads applied ± 50 daN,
- (b) Movements ± 0.01 mm.

3.3.3.2.1.4. Test procedure

3.3.3.2.1.4.1. The coupling device shall first be subjected to a pre-traction load which does not exceed 15 % of the traction test load defined in paragraph 3.3.3.2.1.4.2.

The operation described in paragraph 3.3.3.2.1.4.1 shall be repeated at least twice, starting with a zero load, which is gradually increased until the value prescribed in paragraph 3.3.3.2.1.4.1 is reached, and then decreased to 500 daN; the settling load shall be maintained for at least 60 seconds.

3.3.3.2.1.4.2. The data recorded for plotting the load/deformation curve under traction, or the graph of that curve provided by the printer linked to the traction machine, shall be based on the application of increasing loads only, starting from 500 daN, in relation to the reference centre of the coupling device.

There shall be no breaks for values up to and including the traction test load which is established as 1.5 times the technically permissible trailer mass; in addition, the load/deformation curve shall show a smooth progression, without irregularities, in the interval between 500 daN and 1/3 of the maximum traction load.

Permanent deformation is recorded on the load/deformation curve in relation to the load of 500 daN after the test load has been brought back to that value.

The permanent deformation value recorded shall not exceed 25 % of the maximum elastic deformation occurring.

3.3.3.2.1.5. The test referred to in paragraph 3.3.3.2.1.4.2 shall be preceded by a test in which an initial load of three times the maximum permissible vertical force (in daN, equal to $g \cdot S/10$) recommended by the manufacturer is

applied in a gradually increasing manner, starting from an initial load of 500 daN, to the reference centre of the coupling device.

During the test, deformation of the coupling device shall not exceed 10 % of the maximum elastic deformation occurring.

The check is carried out after removing the vertical force (in daN, equal to $g \cdot S/10$) and returning to the initial load of 500 daN.

3.3.4. Piton-type couplings (Class h)

As in paragraph 3.3.1. of this Annex.

3.3.5. Clevis-type drawbar coupling, non-swivel around longitudinal axis (Class q)

As in paragraph 3.3.3 of this Annex.

3.3.6. Keeper plates (for all drawbar couplings of classes a, g and h, where present)

For ball, hook and piton-type couplings and equivalent devices, the keeper plate shall be tested using a static force of $F_{s \text{ stat}} = 0.6 \cdot D$ (vertically upwards). No cracks or fractures shall be allowed which affects the functioning of the coupling device.

3.4. Drawbar eyes (Classes d)

3.4.1. Drawbar eyes (classes d40-1 and d40-2) for clevis-type couplings shall be subjected to the same dynamic tests and equivalent loading assumptions (see paragraph 3.3.1).

For drawbar eyes which are used exclusively on full trailers, a test using the horizontal loading assumptions shall be performed.

The test may be performed applying either an alternating or a pulsating test force as specified in paragraph 3.3.1.

3.4.2. Drawbar eyes (class d50) for hitch hooks, tractor drawbars or piton-type couplings shall be tested in the same way as drawbar eyes for clevis-type couplings.

3.5. Drawbar eyes (class r)

As in paragraph 3.3.3 of this Annex.

3.6. Towing frames (Class f)

3.6.1. Towing frames shall be subjected to the same forces during testing as the coupling. The test load shall be applied at a horizontal and vertical distance corresponding to the position of the coupling device which exerts the most critical case on the towing frame.

3.6.2. Test preparation

The tests must be carried out according to paragraph 3.3.3.2.1.2.

3.6.3. Test instruments

The instruments used to record loads applied and movements must conform to paragraph 3.3.3.2.1.3.

3.6.4. Comparison of towing frames

Instead of the mandatory tests, towing frames may be evaluated by comparing calculations. The compared frame must be similar in the major design characteristics to an already tested frame.

3.7. Drawbars (class e)

3.7.1. Drawbars shall be tested in the same way as drawbar couplings (see paragraph 3.3.1.). The Type Approval Authority or Technical Service may waive an endurance test if the simple design of a component makes a theoretical check of its strength possible.

The design forces for the theoretical verification shall be calculated as follows:

$$F_{sc} = 9.81 \cdot \frac{S}{1000} + 0.375 \cdot V$$

Where

V is the force amplitude given in paragraph 3.3.1.1.

F_{sc} is the calculated vertical load.

The permissible stresses shall be in accordance with 5.3. of ISO 7641-1:1983.

Permissible stress of weld shall not exceed 90 N/mm².

For bended drawbars (e. g. swan neck) and for the drawbars of full trailers, the horizontal force component $F_{hp} = 1.0 \cdot D$ shall be taken into consideration

3.7.2. For drawbars for full trailers with free movement in the vertical plane, in addition to the endurance test or theoretical verification of strength, the resistance to buckling shall be verified either by a theoretical calculation with a design force of $3.0 \cdot D$ or by a buckling test with a force of $3.0 \cdot D$.

The permissible stresses in the case of calculation shall be in accordance with paragraph 3.7.1

3.7.3. In the case of steered axles, the resistance to bending shall be verified by theoretical calculations or by a bending test. A horizontal, lateral static force shall be applied in the centre of the coupling point. The magnitude of this force shall be chosen so that a moment of $0.6 \cdot A_v \cdot g$ (kNm) is exerted about the front axle centre. The permissible stresses shall be in accordance with paragraph 3.7.1.

Annex 7

Installation and special requirements

1. Tractors
 - 1.1. A tractor may be equipped with one or more mechanical coupling devices according to 2.6. in connection with Table 6 of Annex 5.
 - 1.2. If a tractor is equipped with mechanical coupling devices according to 2.6. in connection with Table 6 of Annex 5, at least one of the devices shall have the characteristic values D , D_c , S , A_v and v_{max} corresponding to the maximum permissible characteristic values of the tractor as stated by the tractor manufacturer.
2. Towed vehicles

Mechanical coupling devices of towed vehicles according to 2.6. in connection with Table 6 of Annex 5 for connecting the towed vehicle to a tractor shall have at least the characteristic values D , D_c , S , A_v and v_{max} corresponding to the maximum permissible characteristic values of the towed vehicle as stated by the towed vehicle manufacturer.