



**Committee of Experts on the Transport of Dangerous Goods
and on the Globally Harmonized System of Classification
and Labelling of Chemicals**

**Sub-Committee of Experts on the Globally Harmonized
System of Classification and Labelling of Chemicals**

Thirty-fifth session

Geneva, 4-6 July 2018

Item 4 (a) of the provisional agenda

Hazard communication: labelling of small packagings

Labelling of sets or kits

**Transmitted by the European Chemical Industry Council (CEFIC) on
behalf of the informal correspondence group***

Introduction

1. At its thirty-fourth session, the Sub-Committee noted that the informal correspondence group had considered proposals to further improve the examples for sets or kits and that a revised proposal would be submitted to the thirty fifth session. The proposal in this document takes account of all comments received.

Proposal

2. Add a new example “Labelling of sets or kits” in annex 7 of the GHS as set out hereafter.

* In accordance with the programme of work of the Sub-Committee for 2017–2018 approved by the Committee at its eighth session (see ST/SG/AC.10/C.3/100, paragraph 98 and ST/SG/AC.10/44, paragraph 14).

“Example 10: Labelling of - sets or kits

A set or kit is a combination packaging intended for defined applications. Generally a set or kit contains two or more small removable inner containers. Each inner container contains different products which can be hazardous or not hazardous substances or mixtures.

This example illustrates ways to label sets or kits where the manufacturer/supplier or competent authority has determined there is insufficient space to place together on each inner container within the kit, the GHS pictogram(s), signal word and hazard statement(s) in accordance with 1.4.10.5.4.1. This may occur when, for example, the inner containers are small, or there are a large number of hazard statements assigned to the chemical, or the information needs to be presented in multiple languages, so all the information cannot be printed on the label in a size that is easily legible. Two different scenarios where this may arise are illustrated, together with ways to provide the necessary GHS information.

Scenario A

The set or kit comprises an outer packaging containing the following inner containers: four cuvettes, each filled with the same substance or mixture (reagent 1) and two larger containers each filled with another substance or mixture (reagent 2).

The approach is to provide minimum information on each of the inner containers containing hazardous substances or mixtures, and to provide the full GHS label information for each hazardous substance or mixture on the outer packaging. For clarity, the full label information for each hazardous substance or mixture is grouped together on the outer packaging.

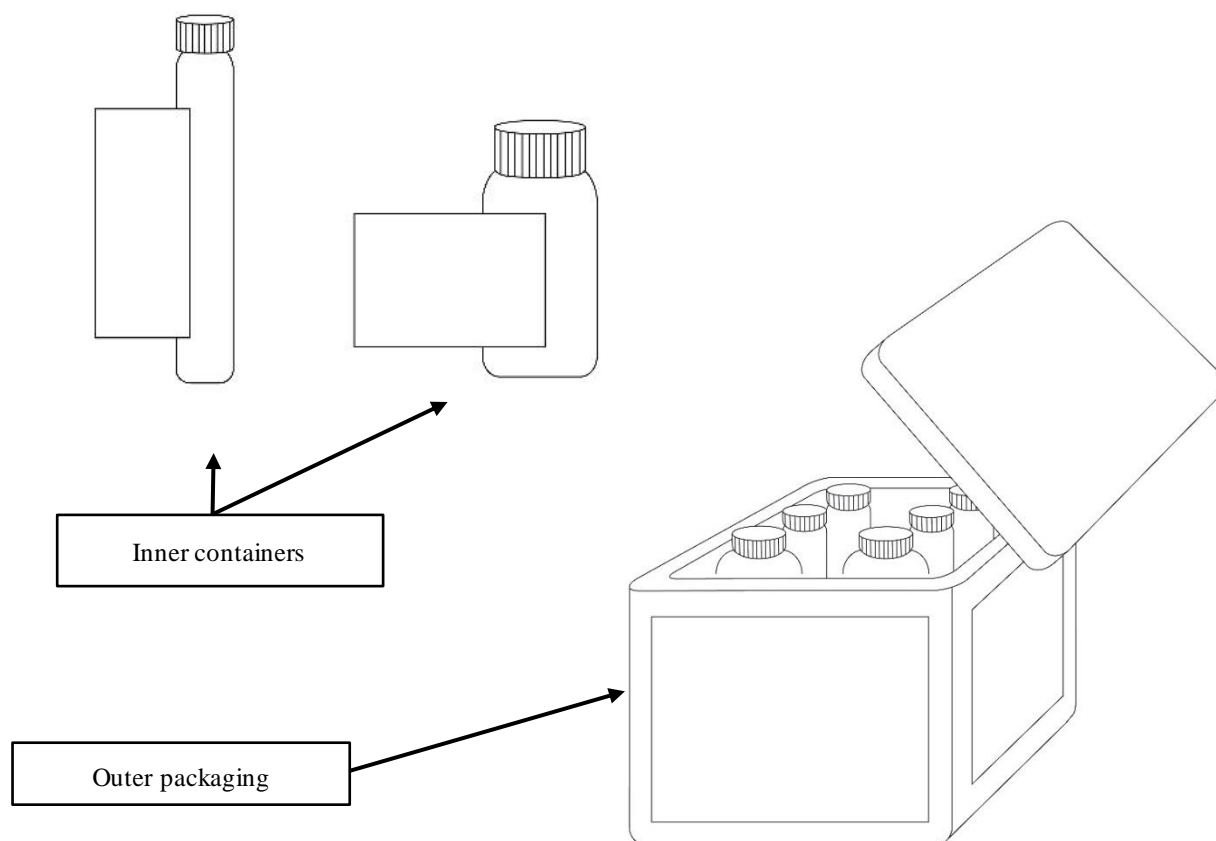

Inner container label

As the area available for a label on the inner containers is not sufficient to include all the required GHS label elements, the following minimum information is included on the label of each hazardous substance or mixture:

- Product identifier¹, and an identifier for each substance or mixture matching the identifier used on the outer packaging label and SDS for that substance or mixture, e.g., “Reagent 1” and “Reagent 2”
- Pictogram(s)
- Signal word
- The statement “Read full label”
- Supplier identification (i.e. name and telephone number)

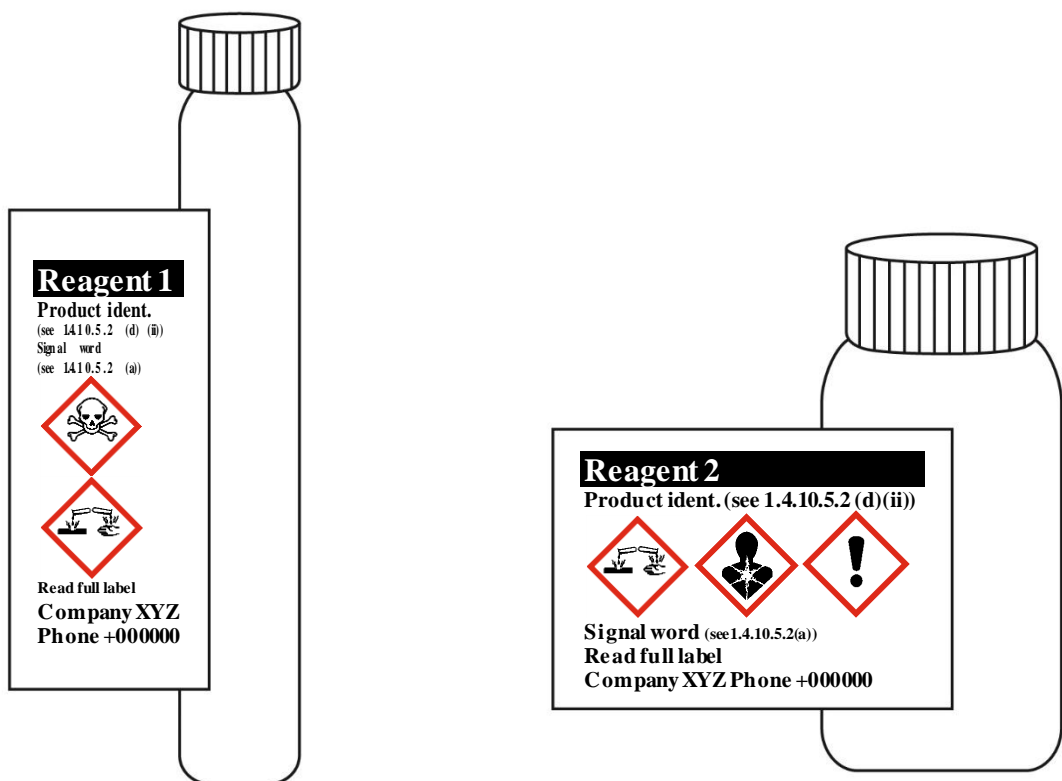

Outer packaging label

In addition to the set or kit identifier, in this case Reagent Kit for water analysis (see below), all the required GHS label elements appear on the outer packaging for each hazardous substance or mixture.

The label elements for each substance or mixture on the outer packaging are grouped together in order to distinguish clearly which label elements are assigned to which substance or mixture.

¹ Where hazardous components are required on the label, they are displayed in the appropriate languages on the outer packaging label.

However, the supplier identification need appear only once on the outer packaging. Where possible any supplemental information may also be included on the outer packaging.

When a large number of precautionary statements are required, the precautionary statements may be located separately from the rest of the label elements, though general precautionary statements (Table A3.2.1) and precautionary statements for storage need only appear once (see also A3.3.2 in Annex 3 on flexibility in the use of precautionary statements to avoid inappropriate statements, taking into account the nature of the user (e.g. consumers, employers and workers) the quantities supplied, and the intended and foreseeable circumstances of use. In these circumstances, the precautionary statements for each substance or mixture should be grouped together on the same side of the outer packaging and on a surface that is visible under normal conditions of use.

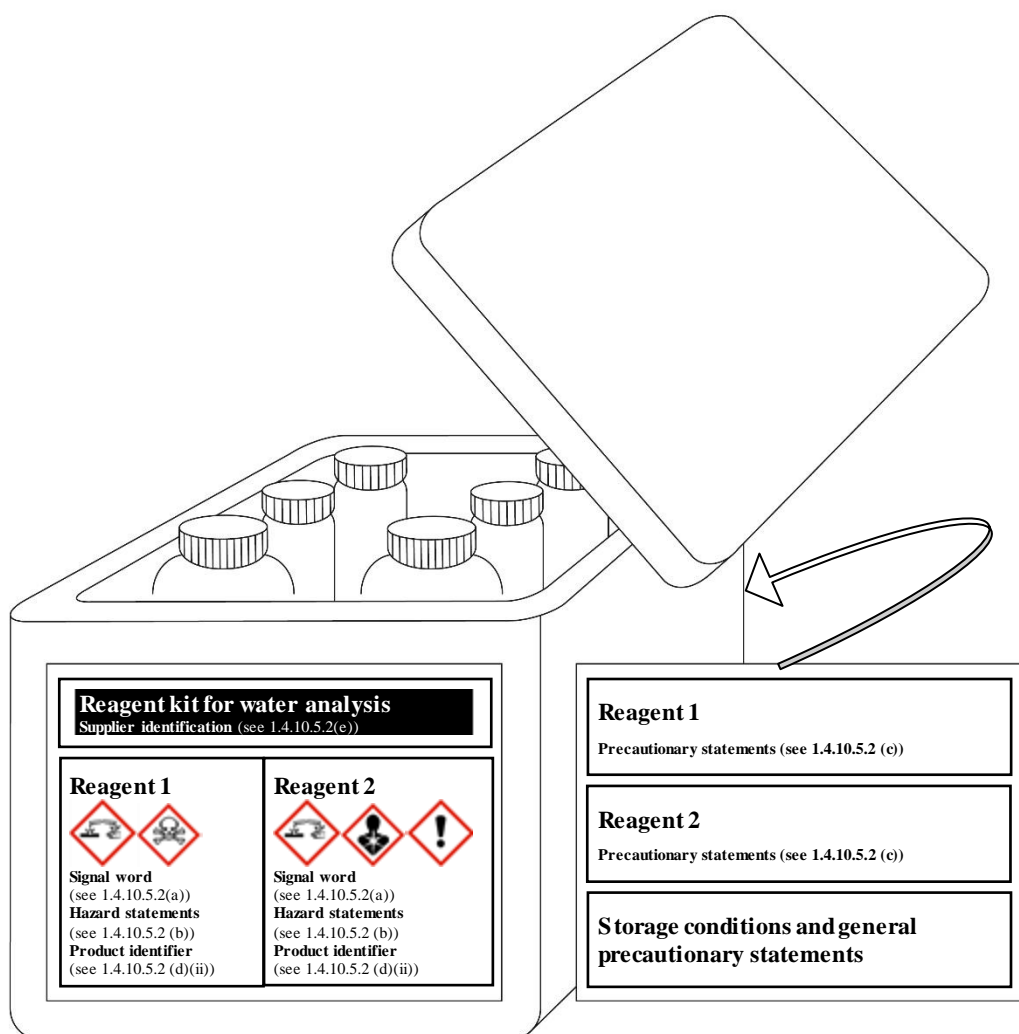

Scenario B

This scenario addresses the situation where it is not possible to affix all appropriate GHS labelling elements for each hazardous substance or mixture in the kit directly on the outer packaging label (due to technical reasons such as the size and shape of this packaging).

This scenario presents a sample kit used for marketing purposes which consist of a large number of different substances or mixtures in individual containers (sample bottles)

presented in an outer packaging (e.g. a box). Depending upon the contents of each bottle, some or all of the different substances or mixtures may be classified as hazardous. The individual inner containers (e.g. bottles) are stored in the outer packaging throughout the lifecycle of the sample kit. Customers may select individual bottles and remove them from the box to check clarity, colour or odour and then replace them into the open slot within the outer packaging.

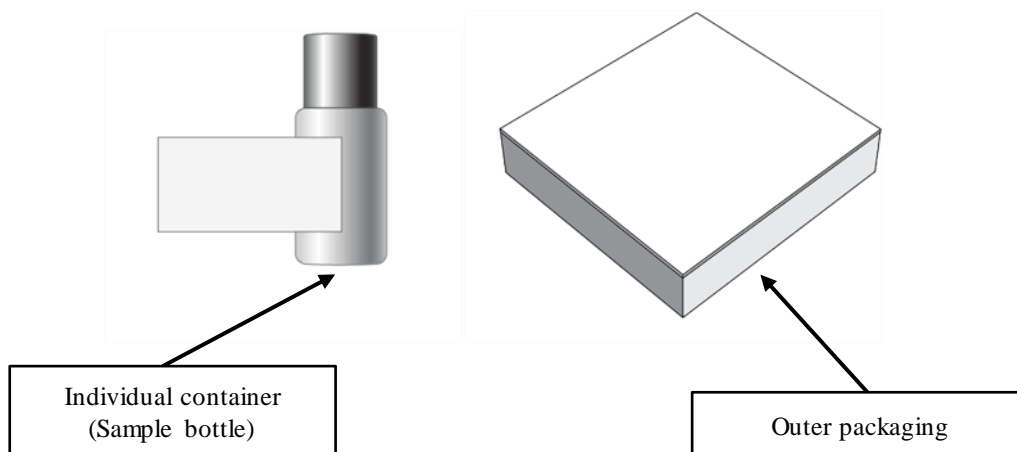

Individual container label

As the area available for a label on the different individual containers is not sufficient to include all required GHS label elements, the following minimum required information should be required:

- supplier identification (i.e. name and telephone number)
- product identifier¹
- pictogram(s)
- signal word
- the statement “Read full label enclosed”

¹ Where hazardous components are required to be identified on the label they are displayed in the appropriate languages as part of the full label information attached to the inside of the kit.

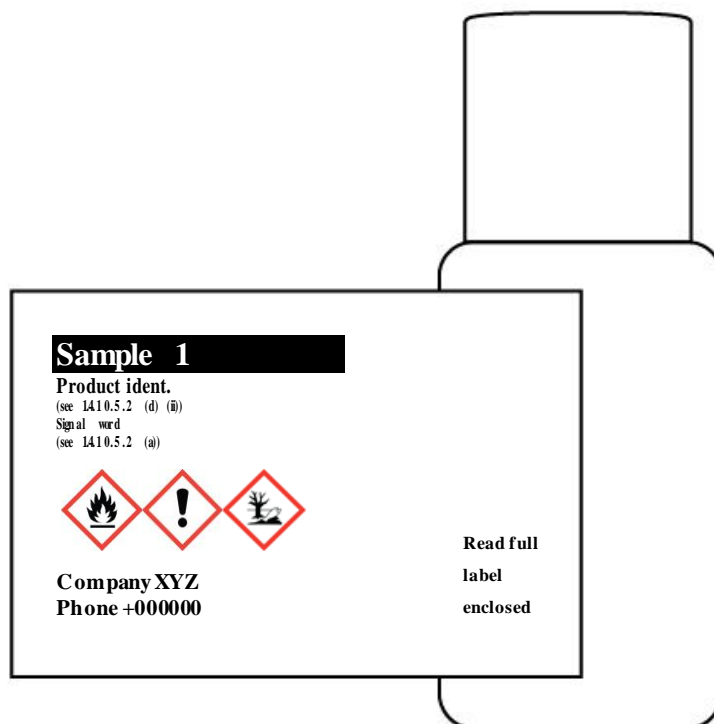

Example of individual container label

Full label information

Attached to the inside of the outer packaging is the full GHS label information for each individual container containing a hazardous substance or mixture. The individual product identifiers on the label align with the product identifier on the individual container label. An example of the content of the full label information is shown below.

Product identifier (see 1.4.10.5.2 (d) (ii))	Pictogram(s) (see 1.4.10.4)	Signal word (see 1.4.10.5.2 (a))	Hazard statement(s) (see 1.4.10.5.2 (b))	Precautionary statement(s) (see 1.4.10.5.2 (c))	Supplemental information (see 1.4.10.5.4.2)
123		Warning	Flammable liquid and vapour. Causes skin irritation. Toxic to aquatic life with long lasting effects.	Keep away from heat, hot surfaces, sparks, open flames and other ignition sources. No smoking. Keep container tightly closed. Use explosion-proof equipment. Use non-sparking tools. Take action to prevent static discharge.	

Product identifier (see 1.4.10.5.2 (d) (ii))	Pictogram(s) (see 1.4.10.4)	Signal word (see 1.4.10.5.2 (a))	Hazard statement(s) (see 1.4.10.5.2 (b))	Precautionary statement(s) (see 1.4.10.5.2 (c))	Supplemental information (see 1.4.10.5.4.2)
				Avoid release to the environment. Wear protective gloves. IF ON SKIN (or hair): Take off immediately all contaminated clothing. Rinse skin with water. In case of fire: Use dry sand, dry chemical or alcohol-resistant foam for extinction. Store in a well-ventilated place. Keep cool.	

Although the contents of each inner container may not be classified as hazardous according to the GHS, and thus would not need to be identified, it may be identified with a statement such as “Not meeting classification criteria” or “Not classified as hazardous” so as to eliminate confusion on the part of the user if the contents of an inner container is omitted from the full label information.

The document containing the full GHS label information should be organized and printed in a format that allows the user to readily identify the information for each individual container. The visibility of the label elements should be ensured without the aid of any device other than corrective lenses. The approach of this scenario may become infeasible if, given the number of samples, required languages, and precautionary statements, the document grows so large it becomes difficult to locate quickly the label information for a particular inner container.

As shown to the right, full label information regarding each inner container is contained within the outer packaging.

The sheets of full label information are permanently connected to the inside of the combination packaging using a secure method of attachment (e.g. fold out label adhered to box tie or tag as shown)

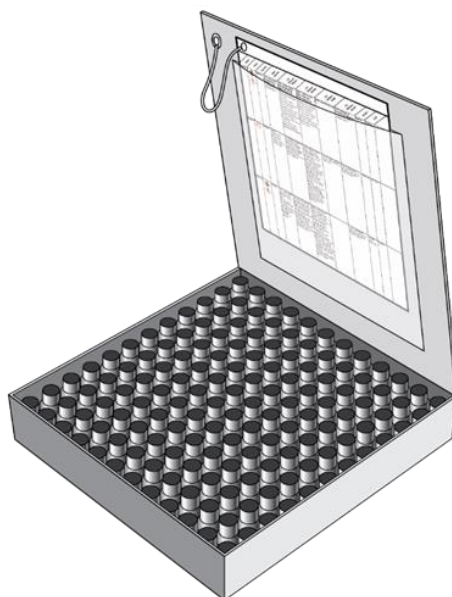

Outer packaging label

The outer box, given the limited area for labelling, will display:

- kit identifier (name of kit)
- supplier identification (see 1.4.10.5.2(e))
- storage and general precautionary statements for the kit as a whole
- pictograms for each single hazardous substance or mixture, without duplication
- signal word (the most stringent assigned to any component)
- the statement “Read full label enclosed”.

MARKET KIT

Product ident. (see 1.4.10.5.2 (d) (ii))

Signal word (see 1.4.10.5.2 (a))



Precautionary Storage Statements (see 1.4.10.5.2 (c))

Read full label enclosed

Supplier identification (see 1.4.10.5.2 (e))