

Proposal for Supplement 2 to the 02 series of amendments to Regulation No. 129

Submitted by the expert from France*

The text reproduced below was prepared by the expert from France, on behalf of the informal group on Child Restraints Systems and updates the latest version of Regulation No 129. The modifications to the current text of the UN Regulation are marked in bold for new or strikethrough for deleted characters. **This document supersedes ECE/TRANS/WP.29/GRSP/2017/16. It includes all proposals of modifications made by the IWG ECRS during the three last meetings (2017/01/25, 2017/03/09 and 2017/04/19.**

Deleted: -----Page Break-----

I. Proposal

Insert new paragraph 4.9., to read:

"4.9. An impact shield that is not permanently attached to the seat shall have a permanently attached label to indicate the brand and model of the **Enhanced Child Restraint System** to which it belongs and the size range. The minimum size of the label shall be ~~40 x 40, mm~~ **or the equivalent area.**"

Deleted: [

Deleted:]

Insert new paragraph 4.10., to read:

"4.10. **Enhanced Child Restraint Systems** shall have a permanently attached label to inform the user of the appropriate method of restraint of the child over the entire stature range declared by the manufacturer.

The label shall be visible to the person installing the child restraint in a vehicle **and when a child is seated in the restraint. The label shall have a minimum size of 40 x 60 mm, or the equivalent area and, shall feature a pictogram of each restraint configuration adjacent to the stature range.**"

Deleted: ,

Deleted: with

Deleted: [

Deleted:]

Deleted: . The label

Paragraph 6.2.1.4., amend to read:

"6.2.1.4. To prevent submarining, either by impact or through restlessness, a crotch strap shall be required on all integral forward-facing restraints incorporating an integral harness belt system. **Enhanced Child Restraint Systems which incorporate a shield instead of a harness shall ensure that the shield**

* In accordance with the programme of work of the Inland Transport Committee for 2016–2017 (ECE/TRANS/254, para. 159 and ECE/TRANS/2016/28/Add.1, cluster 3.1), the World Forum will develop, harmonize and update Regulations in order to enhance the performance of vehicles. The present document is submitted in conformity with that mandate.



extends across the full width of the child's body and sits low on the pelvis."

Paragraph 6.2.1.8., amend to read:

"6.2.1.8. With the crotch strap attached and in its longest position if adjustable, it shall not be possible to adjust the lap strap to lie above the pelvis of both the smallest and largest dummy within the size range covered by the approval. For all forward-facing restraints, it shall not be possible to adjust the lap strap to lie above the pelvis of both the smallest and largest dummy within the size range covered by the approval.

An impact shield shall be adjustable so that it comes in contact with the pelvis and abdomen of the smallest and largest dummy within the size range covered by the approval, leaving no gap between the impact shield and the dummy."

Paragraph 6.3.2.1., amend to read:

"6.3.2.1. Internal geometric characteristics

The Technical Service conducting the approval tests shall verify that the internal dimensions of the Enhanced Child Restraint System conform to the requirements of Annex 18. The minimum dimensions for shoulder breadth, hip breadth and sitting height shall be fulfilled simultaneously for any stature within the size range declared by the manufacturer.

Integral Enhanced Child Restraint System shall also fulfil the minimum and maximum dimensions of shoulder height, for any stature within the size range declared by the manufacturer.

Integral Enhanced Child Restraint Systems that feature an impact shield shall also be capable of being adjusted to fulfil:

- (a) **The 5th percentile upper leg thickness and 5th percentile abdomen depth, simultaneously to the 5th percentile shoulder height;**
- (b) **The 95th percentile upper leg thickness and 95th percentile abdomen depth, simultaneously to the 95th percentile shoulder height, shoulder breadth, hip breadth and sitting height;**

for any stature within the size range declared by the manufacturer.

Non-integral Enhanced Child Restraint System shall also fulfil the maximum dimensions of shoulder height, for any stature within the size range declared by the manufacturer."

Paragraph 6.6.2.1., amend to read:

"6.6.2.1. For all devices with backrests, the areas defined in Annex 14 to this Regulation, when tested according to Annex 13, shall give a peak acceleration of less than 60 g. This requirement applies also to areas of impact shields which are in the head strike area **as defined in Annex 14.**"

Insert new paragraph 6.6.4.1.8., to read:

"6.6.4.1.8. In the case of a convertible integral Enhanced Child Restraint System that is equipped with a means of restraining the child that is intended for one orientation only, the dynamic test shall be carried out as follows:

6.6.4.1.8.1. With the means of restraint used in the orientation for which it is intended, and

6.6.4.1.8.2. With the means of restraint used in the orientation for which it is not intended, unless a mechanism is provided to prevent such incorrect use."

Paragraph 6.6.4.1.1.1., amend to read:

"6.6.4.1.1.1. Where a test is conducted in accordance with paragraph 6.6.4.1.6.2. or paragraph 6.6.4.1.8.2 above, a tolerance of +10 per cent shall be applicable to the head excursion value distance between Cr point and plane AB."

Paragraph 6.6.4.1.2.1, amend to read:

6.6.4.1.2.1. Head excursion: no part of the head of the dummy shall pass beyond the planes FD, FG and DE, as shown in figure 2 below. This shall be judged up to 300 ms or the moment that the dummy has come to a definitive standstill whatever occurs first.

Except when testing using Q6 dummy where:

- a) The value in relation to the FD plane is 840 mm

Where a test is conducted with paragraph 6.6.4.1.6.2. or paragraph 6.6.4.1.8.2. above, only the second configuration test results without 100 mm diameter bar will be considered.

Formatted: Indent: Left: 4 cm

Figure 2
Arrangement for testing a rearward-facing device, not supported by the dashboard

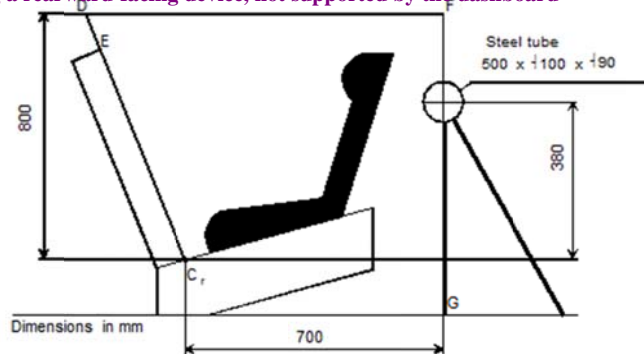

Paragraph 6.6.5.1., amend to read:

"6.6.5.1. Buckle assemblies, retractors, adjusters and lock-off devices that are liable to be affected by temperature, shall be subject to the temperature test specified in paragraph 7.2.7. below. **This requirement is applicable to any such components that are found on the Enhanced Child Restraint System, regardless of the means of restraint.**"

Paragraph 6.7., amend to read:

"6.7. Provisions applicable to individual components of the restraint
This paragraph is applicable to any such components that are found on the Enhanced Child Restraint System, regardless of the means of restraint."

Paragraph 6.7.1.8.2., amend to read:

"6.7.1.8.2. Depending on the mass limit declared by the manufacturer, a ~~harness~~ buckle shall withstand:"

Paragraph 6.7.2.7., amend to read:

"6.7.2.7. An adjuster mounted directly on the Child Restraint System shall be capable of withstanding repeated operation and shall, before the dynamic test prescribed in paragraph 7.1.3. undergo a test comprising 5,000 ± 5 cycles as specified in paragraph 7.2.6.1.

An adjuster mounted on a strap shall be capable of withstanding repeated operation and shall, before the dynamic test prescribed in paragraph 7.1.3. undergo a test comprising 5,000 ± 5 cycles that applies the principles of the test specified in paragraph 7.2.3. This test shall be defined by the Technical Service in consultation with the manufacturer."

Insert new paragraph 7.1.3.6.5., to read:

- "7.1.3.6.5. The test specified in 6.6.4.1.8. above is a requirement only for:
- 7.1.3.6.5.1. The smallest dummy for which the Enhanced Child Restraint is designed, if the means of restraint is an impact shield.
- 7.1.3.6.5.2. The largest dummy for which the Enhanced Child Restraint is designed, if the means of restraint is a harness."

~~Insert new paragraph 7.2.6., to read:~~

~~"7.2.6. Conditioning tests for adjusters"~~

Moved (insertion) [1]

Paragraph 7.2.6., amend to read:

"7.2.6.1 Conditioning test for adjusters mounted directly on a child restraint"

...

Moved up [1]: Insert new paragraph 7.2.6., to read:
"7.2.6. Conditioning tests for adjusters"

Insert new paragraph 7.2.6.2., to read:

7.2.6.2. Conditioning test for adjusters connected to a strap (not directly mounted to the Enhanced Child Restraint System)

Install the largest dummy for which the restraint is intended, as if for the dynamic test, including the standard slack as specified in paragraph 7.1.3.5. above. Mark a reference line on the strap where the free end of the strap enters the adjuster.

Remove the dummy and place the restraint in the conditioning rig shown in Figure 2, Annex 15.

The strap shall be cycled for a total distance of not less than 150 mm through the adjuster. This movement shall be such that at least 100 mm of strap on the side of the reference line towards the free end of the strap.

If the length of strap from the reference line to the free end of the strap is insufficient for the movement described above, the 150 mm of movement through the adjuster shall be from the fully extended strap position.

The frequency of cycling shall be 10 ± 1 cycles/minute, with a velocity on 'B' of 150 ± 1 mm/s.

This process shall be conducted for each adjuster that is part of the retention system of the child within the restraint.

Paragraph 9.2.1.1., amend to read:

"9.2.1.1. Five Enhanced Child Restraint Systems shall be subjected to the dynamic test described in paragraph 7.1.3. above. The Technical Service that conducted the type approval tests shall choose the conditions that produced the maximum horizontal head excursion during the type approval dynamic tests, excluding the conditions described in paragraph 6.6.4.1.6.2. and paragraph 6.6.4.1.8.2. above. All the five Enhanced Child Restraint Systems shall be tested under the same conditions."

Paragraph 14.3.5., amend to read:

"14.3.5. It shall be recommended that any straps holding the restraint to the vehicle should be tight, that any support-leg should be in contact with the vehicle floor, that any straps **or impact shields** restraining the child should be adjusted to the child's body, and that straps should not be twisted;"

Paragraph 14.3.6., amend to read:

"14.3.6. The importance of ensuring that any lap strap is worn low down, **and that any impact shield installed properly**, so that the pelvis is firmly engaged, shall be stressed;"

Annex 14, amend to read:

"Annex 14

Method of defining head impact area of devices with backrests **or impact shields** and for rearward-facing devices defining the minimum size of side wings

1. **Head impact area**

1.1. **Definition of backrest head impact area**

Place the device on the test bench described in...

1.2. **Definition of impact shield head impact area**

The impact shield head impact area is the whole upper surface of the impact shield, which comprises any surfaces visible from the top, looking down on the shield."

Annex 15, amend to read

“Description of conditioning for adjusters connected to a strap

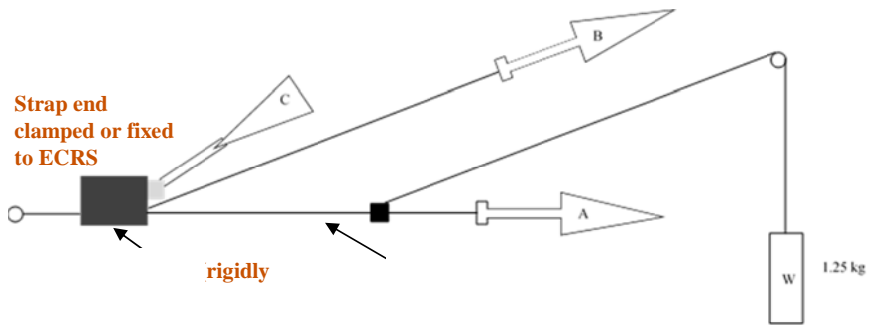

1. Method
 - 1.1. Rigidly clamp the adjuster
 - 1.2. With the strap set at the reference position described in paragraph 7.2.6., withdraw at least 50 mm of strap from the adjuster by pulling on the free end of the strap.
 - 1.3. Attach the adjuster part of the strap to the pulling device A.
 - 1.4. Activate the adjuster (C) and pull at least 150 mm of strap through the adjuster. This represents half of one cycle and puts pulling device A to the maximum strap extraction position.
 - 1.5. Connect the free end of the strap to pulling device B.
2. The cycle is:
 - 2.1. Pull B at least 150 mm whilst A exerts no tension on the strap.
 - 2.2. Activate the adjuster (C) and pull A whilst B exerts no tension on the free end of the strap.
 - 2.3. At the end of the stroke, de-activate the adjuster.
 - 2.4. Repeat the cycle as specified in paragraph 6.7.2.7. of this regulation.”

Annex 18, amend to read:

"Annex 18

Geometrical dimensions of Enhanced Child Restraint Systems

Figure 1.

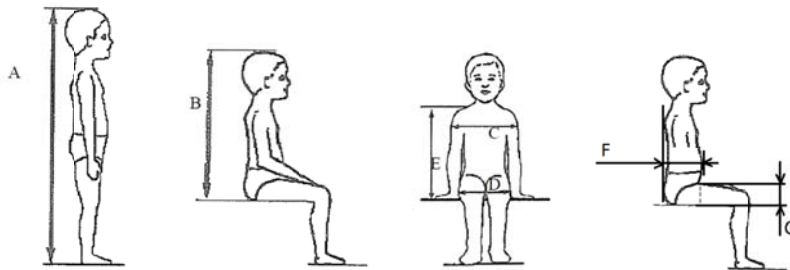

Table 1

Deleted: ¶

[1]

Applicable to all ECRS						Additional internal dimensions for ECRS with impact shield systems			
	Min	Min	Min	Min	Max	Min	Max	Min	Max
Stature	Sitting height cm	Shoulder breadth cm	Hip breadth cm	Shoulder height cm	Shoulder height cm	Abdomen depth cm	Abdomen depth cm	Upper leg thickness cm	Upper leg thickness cm
A	B	C	D	E1	E2	F1	F2	G1	G2
	95%ile	95%ile	95%ile	5%ile	95%ile	5%ile	95%ile	5%ile	95%ile
≤40				< 27.4		Not allowed for these dimensions and stature below 76 cm			
45	39.0	12.1	14.2	27.4	29.0				
50	40.5	14.1	14.8	27.6	29.2				
55	42.0	16.1	15.4	27.8	29.4				
60	43.5	18.1	16.0	28.0	29.6				
65	45.0	20.1	17.2	28.2	29.8				
70	47.1	22.1	18.4	28.3	30.0				
75	49.2	24.1	19.6	28.4	31.3	12.5	15.1	5.7	8.4
80	51.3	26.1	20.8	29.2	32.6	12.7	15.7	5.8	8.4
85	53.4	26.9	22.0	30.0	33.9	12.9	16.2	5.9	8.5

90	55.5	27.7	22.5	30.8	35.2	13.1	16.8	6.2	8.5
95	57.6	28.5	23.0	31.6	36.5	13.3	17.8	6.5	8.9
100	59.7	29.3	23.5	32.4	37.8	13.5	18.2	6.5	9.6
105	61.8	30.1	24.9	33.2	39.1	13.6	18.8	6.6	10.3
110	63.9	30.9	26.3	34.0	40.4	13.9	19.6	6.6	10.3
115	66.0	32.1	27.7	35.5	41.7	13.9	19.9	6.6	10.4
120	68.1	33.3	29.1	37.0	43.0	14.3	20.2	6.8	10.5
125	70.2	33.3	29.1	38.5	44.3	14.7	20.7	7.5	10.9
130	72.3	33.3	29.1	40.0	46.1	Not allowed for these dimensions and stature over 125 cm			
135	74.4	33.3	29.1	41.5	47.9				
140	76.5	34.2	29.6	43.0	49.7				
145	78.6	35.3	30.8	44.5	51.5				
150	81.1	36.4	32.0	46.3	53.3				

All lateral dimensions are measured under a contact force of 50 N with the devices described in Figure 2 & Figure 3 of this annex and the following tolerances will be applied:

Minimum Sitting height:

- up to 87 cm B - 5 per cent

- From stature from 87 cm and up to 150 cm B - 10 per cent,

Minimum shoulder height (5 percentile): $E1_{-2}^{+0}$ cm

Maximum shoulder height (95 percentile): $E2_{-0}^{+2}$ cm

The mass of the devices described in Figure 2 & Figure 3 of this annex shall be 10 kg +/- 1 kg

Deleted:

Internal geometry assessment method

This method describes how to conduct the internal geometry assessment, as required by 6.3.2.1., to verify the stature range of the ECRS declared by the manufacturer.

This assessment shall be carried out for each of the following:

- *For each ECRS orientation (e.g. rearward and forward facing)*
- *For each ECRS type (e.g. integral and non-integral)*
- *For any removable insert (e.g. for use as described by manufacturer's instructions)*
- *For each occupant restraint method (e.g. harness & shield)*

The internal geometry assessment should be conducted with the ECRS placed on a flat surface or connected to a base in the case of ECRS modules.

For integral or non-integral ECRS the device shown in Annex 18, Figure 2 shall be used.

For ECRS with an impact shield the device shown in Annex 18, Figure 3 shall be used.

1 Determining the Minimum Occupant size

The ECRS should be adjusted to fit the smallest occupant (i.e. headrest height, harness height adjustment, appropriate insert, internal padding, impact shield position), whilst still fitting within the required ISO volumetric envelope as defined in 6.3.2.2.

The measurement device shall then be placed in the ECRS. The device shall be aligned centrally to the ECRS.

All measurements shall be taken with the device base in contact with the seat pan of the ECRS and the device backrest in contact with the backrest of the ECRS

The measurements shall be taken in the following order:

1.1 Minimum Shoulder Height (EI)

1.1.1 For integral ECRS:

This measurement shall be taken when the top of the shoulder height cylinders of the device are aligned with the lowest harness slot position. For this alignment, the top of the shoulder cylinder shall be aligned perpendicular to the harness webbing outlet in the ECRS backrest.

A tolerance may be subtracted from this measurement to allow the shoulders of the occupant to be lower than the harness shoulder slots.

Either:

- *If the ECRS instruction manual provided by the manufacturer quantifies the distance the child's shoulder may be below the harness slots, then this distance shall be subtracted from the minimum shoulder height measurement.*
- *If no distance is specified a 2 cm tolerance may be subtracted from the minimum shoulder height measurement*

1.1.2 For non-integral ECRS

This measurement shall be taken when the top of the shoulder height cylinders of the device are aligned without interference with the lowest part of the headrest.

1.1.3 For ECRS with an impact shield:

This measurement shall be taken when the top of the shoulder height cylinders of the device are aligned without interference with the lowest part of the headrest.

1.2 Minimum Upper Leg Thickness (G1)

This requirement only applies to ECRS with impact shields.

Whilst maintaining the minimum shoulder height position (E1), the minimum leg measurement shall be measured when the device is adjusted so that the simulated thighs contact the bottom of the impact shield.

1.3 Minimum Abdomen Depth (F1)

This requirement only applies to ECRS with impact shields

This measurement shall be taken whilst maintaining the minimum leg thickness measurement position (G1) and minimum shoulder height position (E1).

The bottom of the simulated abdomen of the device shall be aligned with the top of the simulated thighs.

The abdomen depth shall be measured when the simulated abdomen contacts the shield.

2 Determining the Maximum Occupant Size

Integral ECRS shall be adjusted to fit the largest occupant (i.e. headrest height, harness height adjustment, impact shield position), whilst still fitting within the required ISO volumetric envelope as defined in 6.3.2.2.1.

Non-integral ECRS shall be adjusted to accommodate children of 135 cm stature or to the largest size of its declared stature range if the upper limit is below 135 cm (i.e. headrest), whilst still fitting within the required ISO volumetric envelope as defined in 6.3.2.2.2.

The measurement device shall then be placed in the ECRS. The device shall be aligned centrally to the ECRS.

The measurements shall then be taken in the following order:

2.1 Sitting Height (B)

This measurement shall be taken to the highest part of the ECRS that is the effective headrest (head pad or backrest).

A tolerance is added to this measurement to allow part of the head to protrude from the ECRS:

- *+5% for stature ranges below 87cm*
- *+10% for statures ranges above 87cm*

2.2 Hip Breadth (D)

The hip breadth measurement shall be taken whilst maintaining the sitting height measurement (B).

The hip breadth measurement shall be taken whilst asserting a 50 N contact force on the ECRS.

If 50 N force cannot be achieved, because the ECRS restricts the space at the simulated thighs then the measurement should be taken at the point the simulated thighs contact the ECRS. There shall be no lateral deformation of the ECRS caused by the measuring device.

2.3 Maximum Shoulder Height (E2)

The maximum shoulder height measurement shall be taken whilst maintaining the sitting height (B) and hip breadth (D) measurements.

2.3.1 For integral ECRS

This measurement shall be taken when the top of the shoulder height cylinders of the device are aligned with the highest harness slot position still fitting within the required ISO volumetric envelope. For this alignment, the top of the shoulder cylinder shall be aligned perpendicular to the harness webbing outlet in the ECRS backrest.

A tolerance may be added to this measurement to allow the shoulders of the occupant to be higher than the harness shoulder slots. However if there is a physical restriction due to the design of the ECRS (e.g. the headrest) that would prevent a child with taller shoulders fitting the tolerance should not be added.

If there is no possible interference then the following tolerances may be added:

- *If the ECRS instruction manual provided by the manufacturer quantifies the distance the child's shoulder may be above the harness slots, then this distance shall be added to the maximum shoulder height measurement.*

- *If no distance is specified a 2 cm tolerance may be added to the maximum shoulder height measurement*

2.3.2 For non-integral ECRS

This measurement shall be taken when the top of the shoulder height cylinders of the device are aligned without interference with the lowest point of the headrest, this includes any belt routing guide.

No tolerance shall be added to this measurement.

2.3.3 For ECRS with an impact shield

This measurement shall be taken when the top of the shoulder height cylinders of the device are aligned without interference with the lowest point of the headrest, this includes any belt routing guide.

No tolerance shall be added to this measurement.

2.4 Maximum Upper Leg Thickness (G2)

This requirement only applies to ECRS with impact shields.

This measurement shall be taken whilst maintaining the sitting height (B), hip breadth (D) and maximum shoulder height (E2) measurements.

The maximum upper leg thickness measurement shall be measured when the device is adjusted so that the simulated thighs contact the bottom of the impact shield.

2.5 Maximum Abdomen Depth (F2)

This requirement only applies to ECRS with impact shields.

This measurement shall be taken whilst maintaining the maximum upper leg thickness (G2), maximum shoulder height (E2), hip breadth (D) and sitting height (B) measurement positions.

The bottom of the simulated abdomen of the device shall be aligned with the top of the simulated thighs.

The abdomen depth shall be measured when the simulated abdomen contacts the shield.

2.6 Shoulder Breadth (C)

The shoulder breadth measurement shall be taken whilst maintaining the sitting height (B) and hip breadth (D) measurements.

The width of the ECRS at the maximum shoulder height measurement position shall be measured whilst asserting a 50N contact force on the ECRS.

If there is no side wing structure to the ECRS at the maximum shoulder height (E2), the shoulder breadth measurement shall be taken at a height, which is the closest proximity to the maximum shoulder height, with side wing structure. If the width of the ECRS between the minimum and maximum shoulder height measurements is not a consistent width i.e. significantly narrower at any point between the E1 and E2 measurements, then an intermediate shoulder breadth measurements shall be taken"

II. Justification

The proposed amendments to the text have been developed to authorise the type approval of integral and non-integral Enhanced Child Restraint Systems equipped with impact shield as restraint device.

A vertical displacement of 840 mm. should be accepted for all dummies, since it's already accepted for the Q10 dummy.

A method describing how to conduct the internal geometry assessment, as required by 6.3.2.1., to verify the stature range of the ECRS declared by the manufacturer was needed.

Deleted: ¶

	<i>Min.</i>	<i>Min.</i>	<i>Min.</i>	<i>Min.</i>	<i>Max</i>	<i>Min.</i>	<i>Max</i>		<i>Minimum</i>	<i>Minimum</i>
<i>Stature</i>	<i>Sitting height cm</i>	<i>Shoulder breadth cm</i>	<i>Hip breadth cm</i>	<i>Shoulder height cm</i>	<i>Shoulder height cm</i>	<i>Abdomen depth cm</i>	<i>Abdomen depth cm</i>		<i>Upper leg thickness cm</i>	<i>Upper leg thickness cm</i>
A	B	C	D	E1	E2	F1	F2		G1	G2
	95%ile	95%ile	95%ile	5%ile	95%ile	5%ile	95%ile		5%ile	95%ile
40	NA	NA	NA	NA	NA	NA	NA		NA	NA
45	39.0	12.1	14.2	27.4	29.0	NA	NA		NA	NA
50	40.5	14.1	14.8	27.6	29.2	NA	NA		NA	NA
55	42.0	16.1	15.4	27.8	29.4	NA	NA		NA	NA
60	43.5	18.1	16.0	28.0	29.6	NA	NA		NA	NA
65	45.0	20.1	17.2	28.2	29.8	NA	NA		NA	NA
70	47.1	22.1	18.4	28.3	30.0	NA	NA		NA	NA
75	49.2	24.1	19.6	28.4	31.3	12,5	15,1		5,7	8,4
80	51.3	26.1	20.8	29.2	32.6	12,7	15,7		5,8	8,4
85	53.4	26.9	22.0	30.0	33.9	12,9	16,2		5,9	8,5
90	55.5	27.7	22.5	30.8	35.2	13,1	16,8		6,2	8,5
95	57.6	28.5	23.0	31.6	36.5	13,3	17,8		6,5	8,9
100	59.7	29.3	23.5	32.4	37.8	13,5	18,2		6,5	9,6
105	61.8	30.1	24.9	33.2	39.1	13,6	18,8		6,6	10,3
110	63.9	30.9	26.3	34.0	40.4	13,9	19,6		6,6	10,3
115	66.0	32.1	27.7	35.5	41.7	13,9	19,9		6,6	10,4
120	68.1	33.3	29.1	37.0	43.0	14,3	20,2		6,8	10,5
125	70.2	33.3	29.1	38.5	44.3	14,7	20,7		7,5	10,9
130	72.3	33.3	29.1	40.0	46.1	NA	NA		NA	NA
135	74.4	33.3	29.1	41.5	47.9	NA	NA		NA	NA
140	76.5	34.2	29.6	43.0	49.7	NA	NA		NA	NA
145	78.6	35.3	30.8	44.5	51.5	NA	NA		NA	NA
150	81.1	36.4	32.0	46.3	53.3	NA	NA		NA	NA