

**Economic and Social Council**Distr.: General
22 September 2017

Original: English

Economic Commission for Europe**Inland Transport Committee****World Forum for Harmonization of Vehicle Regulations****Working Party on Passive Safety****Sixty-second session**

Geneva, 12-15 December 2017

Item 17 of the provisional agenda

UN Regulation No. 129 (Enhanced Child Restraint Systems)**Proposal for Supplement 4 to the 01 series of amendments to
UN Regulation No. 129 (Enhanced Child Restraint Systems)****Submitted by the expert from France***

The text reproduced below was prepared by the expert from France on behalf of the Technical Services Group (TSG) on UN Regulation No. 129 to clarify the test protocol for the opening force of the ISOFIX attachments. The modifications to the current text of UN Regulation No. 129 are marked in bold for new or strikethrough for deleted characters.

* In accordance with the programme of work of the Inland Transport Committee for 2016–2017 (ECE/TRANS/254, para. 159 and ECE/TRANS/2016/28/Add.1, cluster 3.1), the World Forum will develop, harmonize and update Regulations in order to enhance the performance of vehicles. The present document is submitted in conformity with that mandate.

GE.17-16695(E)



* 1 7 1 6 6 9 5 *

Please recycle



I. Proposal

Paragraph 7.2.8., amend to read:

"7.2.8. The complete seat, or the component fitted with ISOFIX attachments (e.g. ISOFIX base) if it has a release button, is attached rigidly to a test rig in such a way that ISOFIX connectors ~~are vertically~~ aligned as shown in Figure 3. A 6 mm diameter bar, 350 mm long, shall be attached to the ISOFIX connectors. A ~~mass force of 5 kg~~ **50 ± 1 N shall be applied to the** ~~shall be attached to the~~ extremities of the bar."

Figure 3, amend to read:

"Figure 3

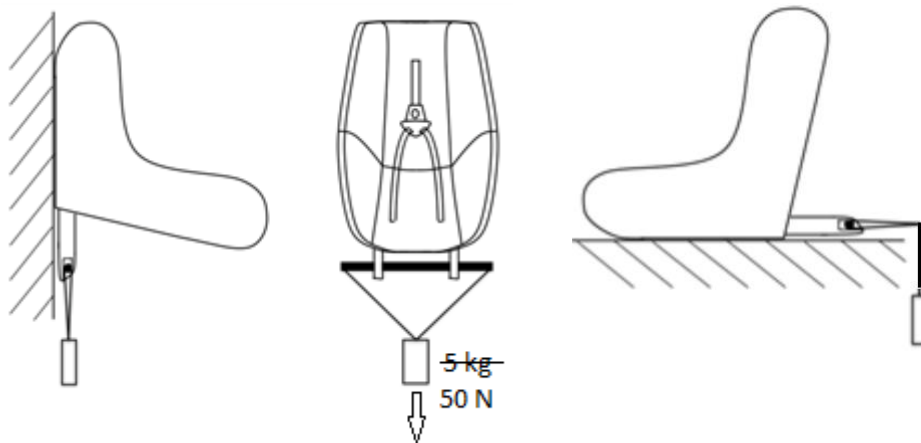

"

II. Justification

Either option is permitted as long as a force of 50 N is applied.
