

REPORT FOLLOWING TECHNICAL INVESTIGATION

**into the collision (and resulting fire)
between a coach and a HGV
that occurred on October 23rd 2015
on Departmental Road No 17
near the town of Puisseguin
(South-West of France)**

1

Observations made at the site of the accident,
expert assessment of the vehicles and
investigations carried out

1

Background to the accident

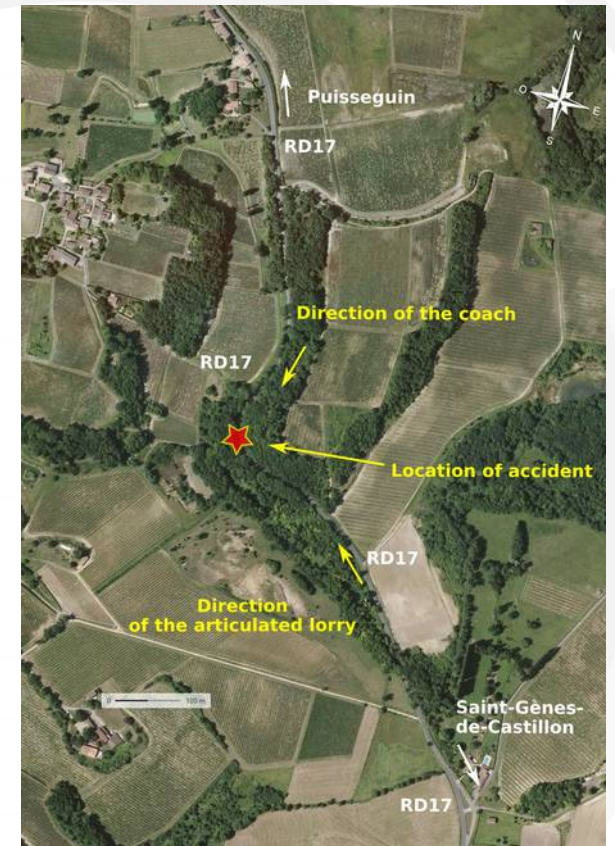
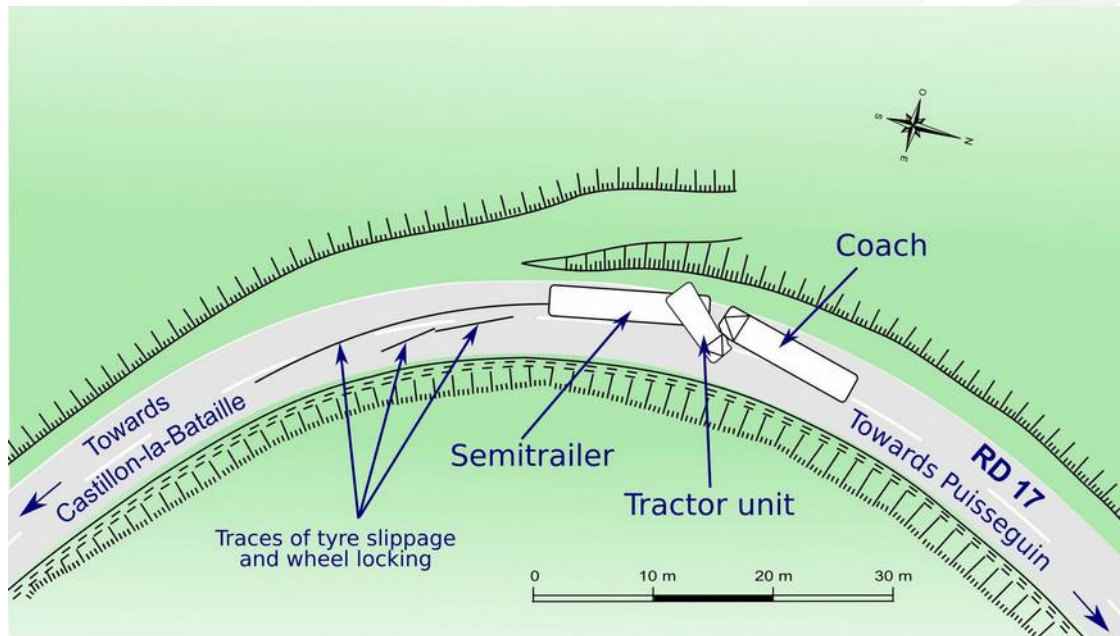

1

View of the right-hand side of the tractor unit involved in the accident

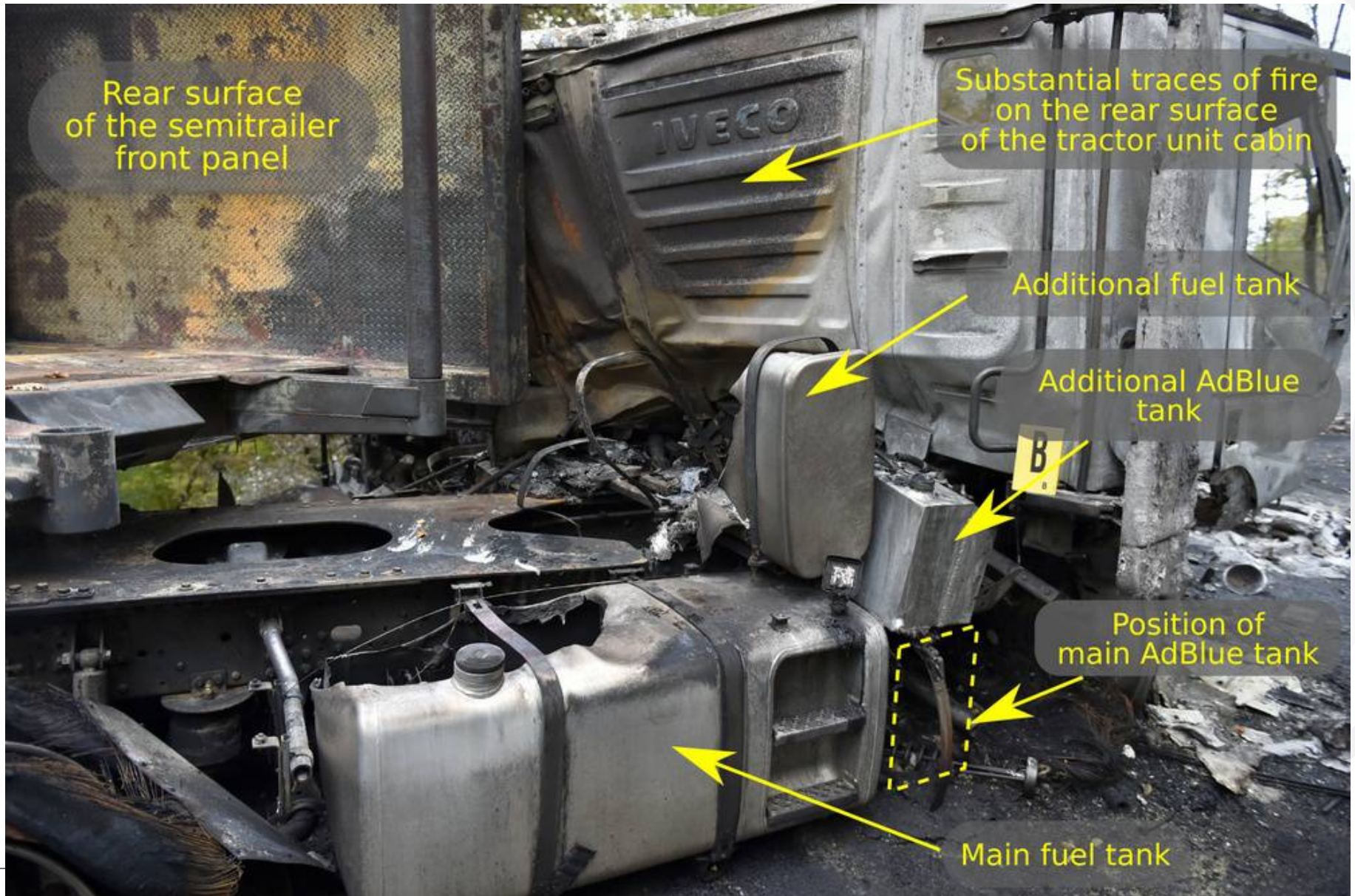

1

Aerial view of the tractor unit

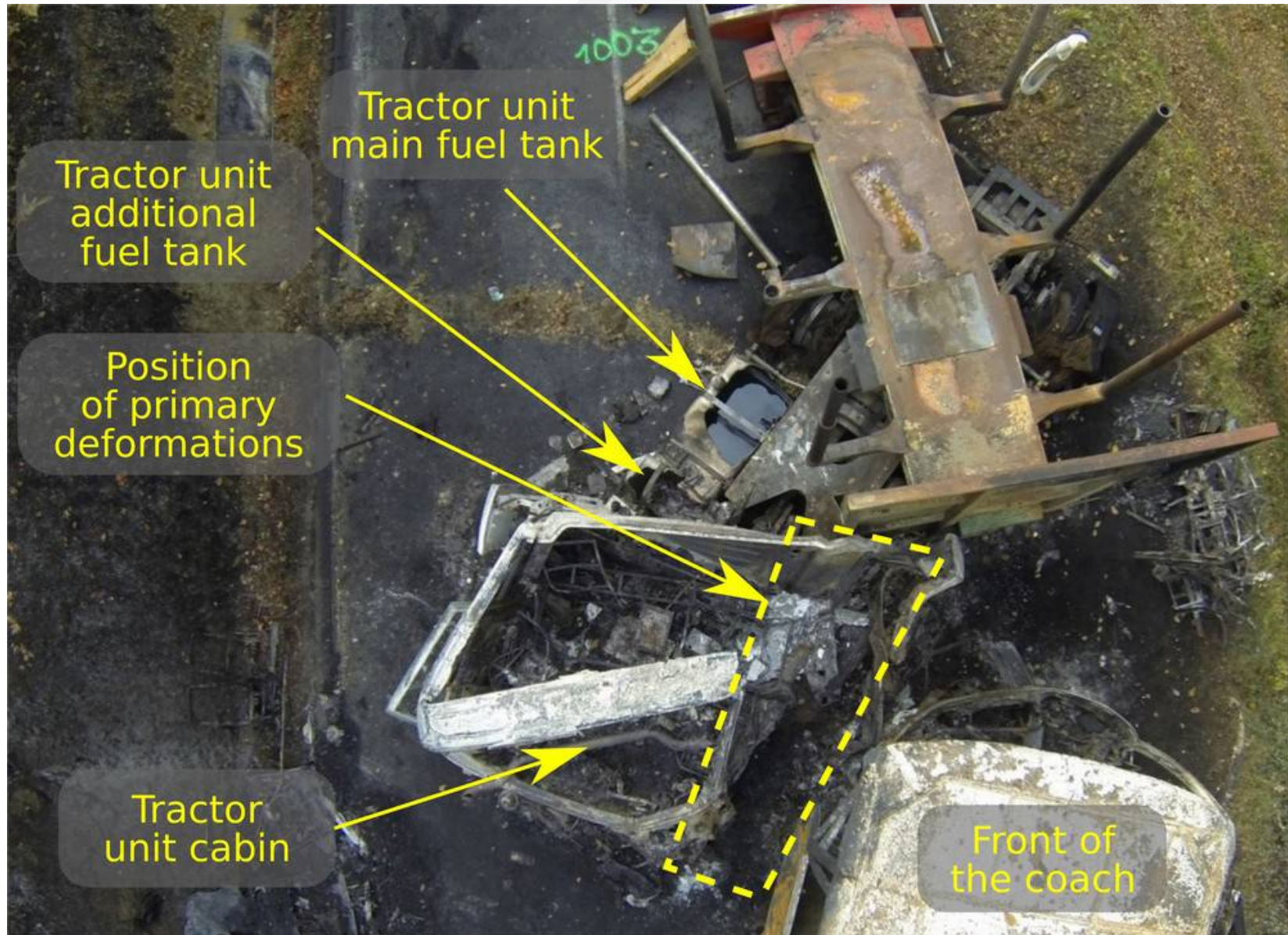

1

View of the front left-hand side of the coach

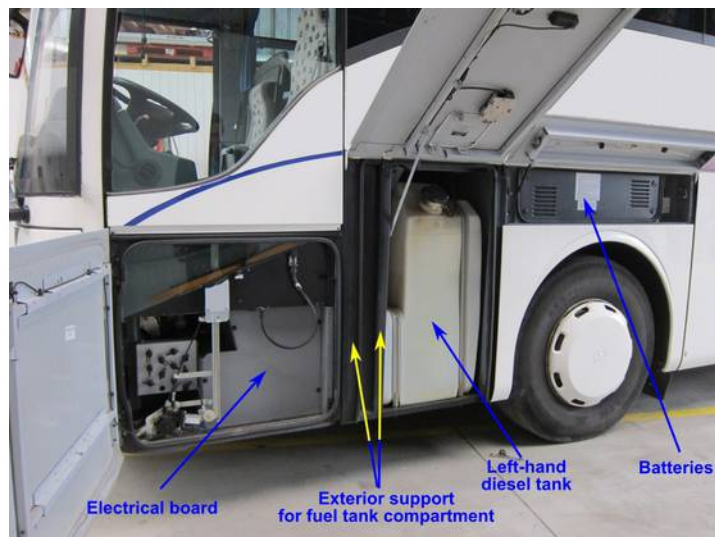
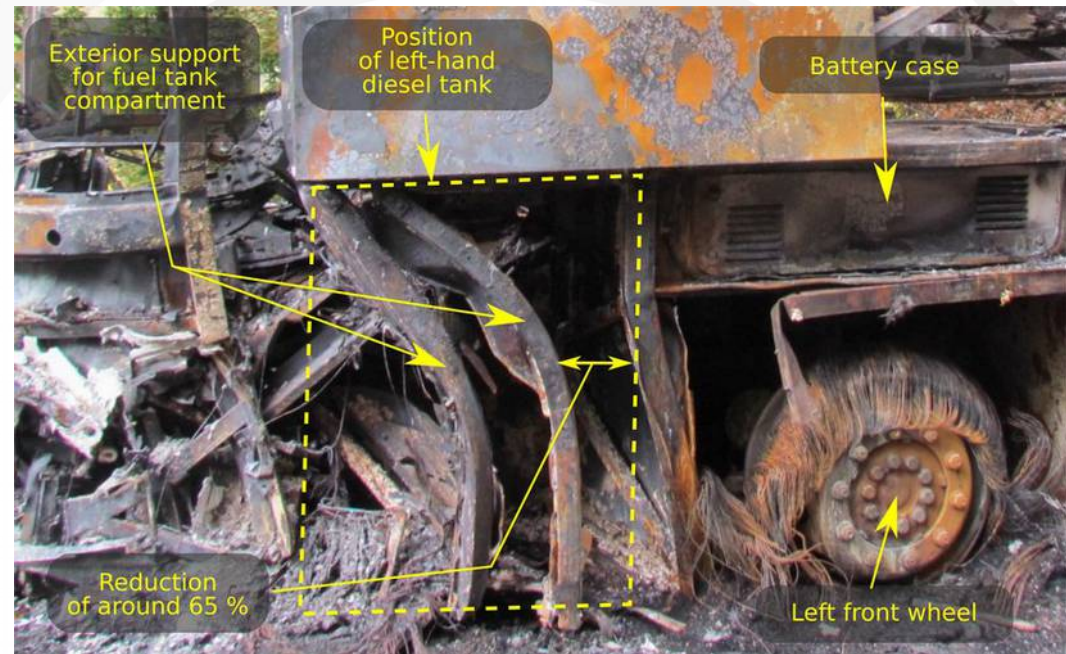

1

Expert assessment of the coach

- The coach (brought into operation in 2011) had been issued with a certificate of compliance.
- it was in **good condition**
- **no modifications or anomalies** were observed which could have influenced **the vehicle's range of motion** before the collision, its response to the impact or its response to the outbreak of a fire

1 Assessment of the Tractor Unit

The assessment **did not show any internal failure** in the tractor unit (brought into operation in 2014) **that might have caused it to malfunction** in the moments leading up to the crash.

The expert assessment showed that following its factory release, **the following modifications had especially been made to the tractor unit:**

- addition of **two tanks behind the cab**: one fuel tank and a tank containing an aqueous urea solution (AdBlue®);
- fifth-wheel coupling moved further towards the rear of the vehicle.



1 Expert analysis of the semitrailer

The trailer unit was first used in 2005

- The examination of its braking system revealed **several defects** (corrosion and cracking of various components, incorrectly connected ABS receptors)
- When the ABS was activated, the trailer was only **able to brake** effectively on **its left-hand side**
- Braking of the right wheels was **weaker** on the third axletree and **stronger** on the first two, causing the wheels to lock



① View of the bend from the position at which the accident occurred, from the direction in which the lorry was travelling



- Road 2x3m wide, without verges
- Visibility reduced by around 40m
- Bends are indicated via warning signs and positional road signs
- Quality of road surface deemed satisfactory

① Kinematic reconstruction of the accident



Position of the vehicles at the moment of impact

Position of the vehicles at 40 m away from each other

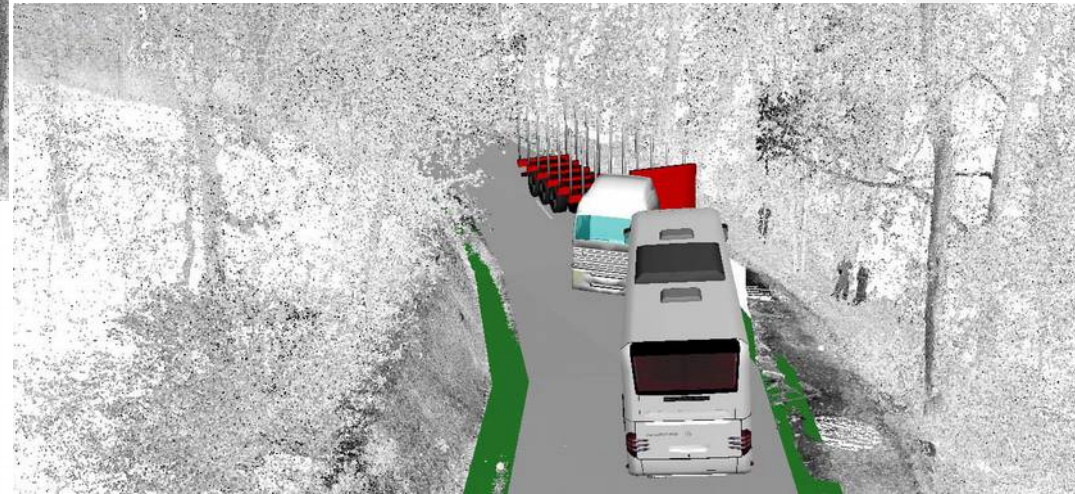

The tractor unit entered the bend at an inappropriate speed given the geometry of the road; the left front steerable wheel entered a skid; the vehicle entered the opposite lane, and the driver braked upon seeing the oncoming coach; the defects observed on the trailer's braking system may have led to or exacerbated the jack-knifing of the lorry; the driver was unable to avoid collision with the oncoming coach.

1

Outbreak and spread of the fire

Main sources of combustible fluids

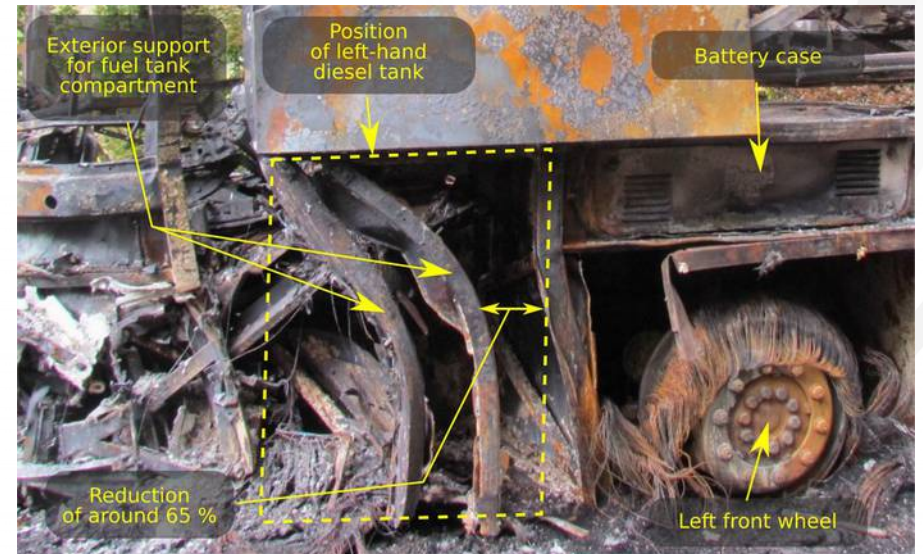
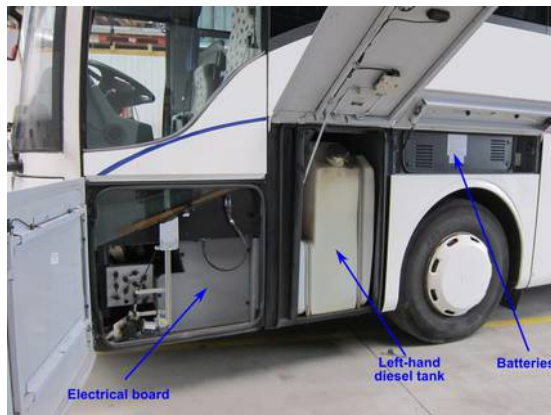

1

Outbreak and spread of the fire

The source of heat at the origin of the conflagration

Tractor Unit

- exhaust line: 500°C-600°C
- device to reduce pollutant levels in exhaust gases
- batteries

Coach

- electrical control unit situated in the front left-hand side
- batteries

Friction between metallic elements

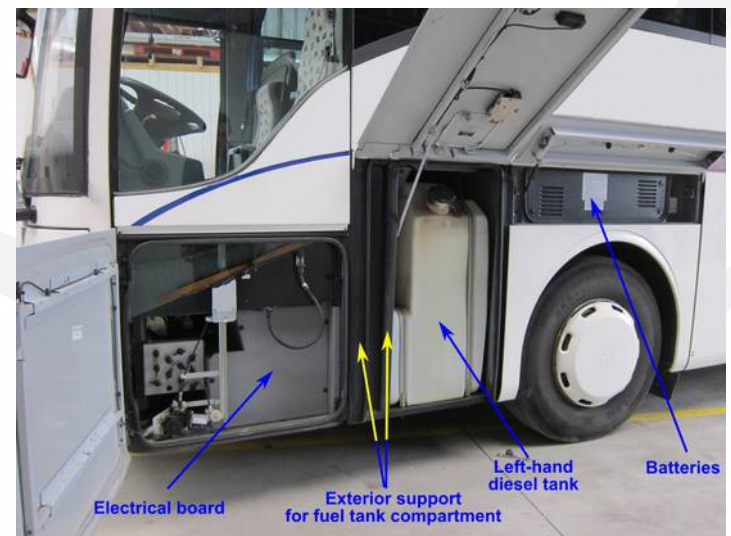

1

Outbreak and spread of the fire

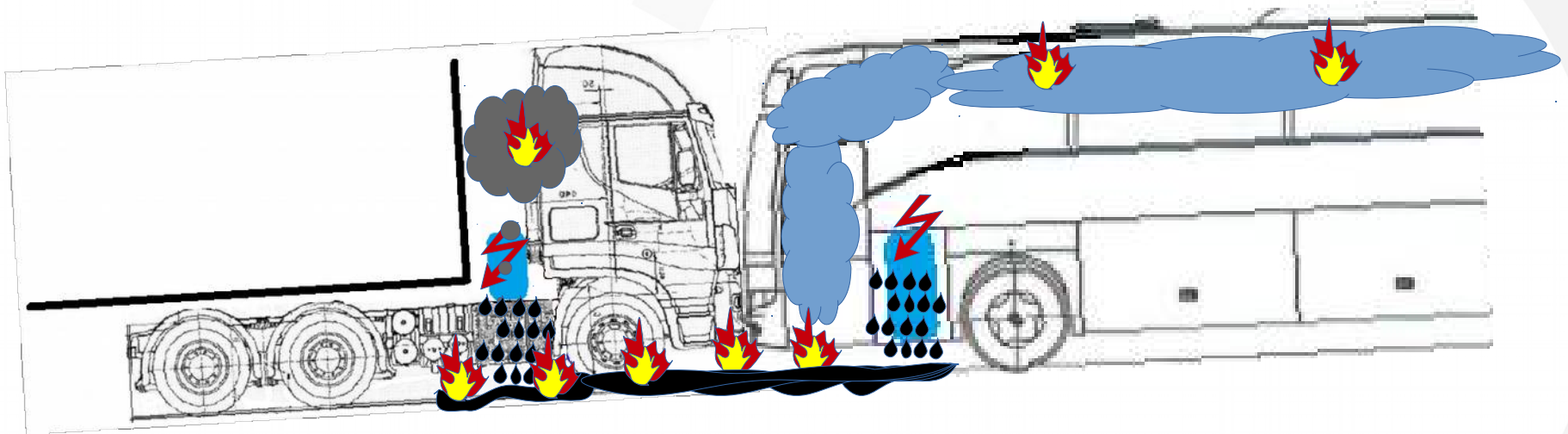

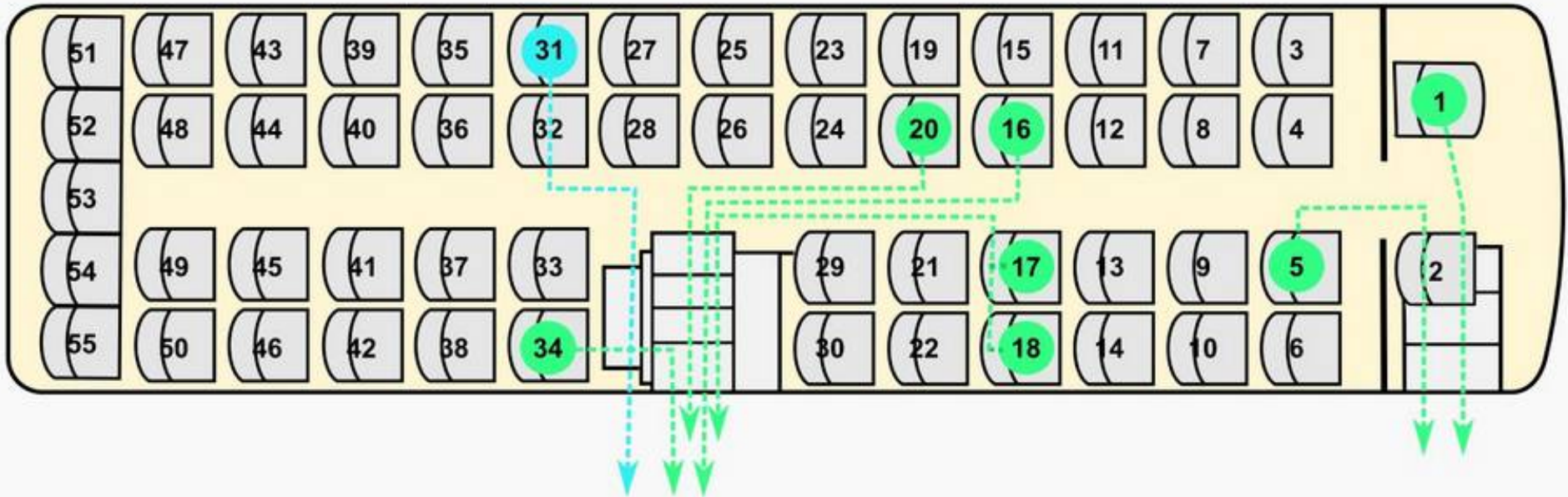

1

Evacuating the coach



Survivor evacuation routes

-  Evacuation via a door
-  Evacuation via an emergency exit

2

Preventative measures and recommendations
formulated by the BEA-TT

Several **factors** played a role in the accident's heavy death toll:

- the speed limit and geometry of the **infrastructure** were unsuitable for the surrounding environment;
- the presence of an **additional diesel fuel tank** on the rear of the tractor unit cabin, which did not comply with existing regulations;
- the nature of the **materials used to fit the interior** of the coach, their level of fire resistance and the toxic gases released upon their combustion;
- the **difficulty** faced by passengers in **operating** the coach's smoke extraction devices, as well as the difficulty in **using** the coach's two exit doors and **emergency exits**;
- the absence of **lighting inside the coach** following the collision.

The BEA-TT has researched preventative recommendations in the following areas:

- road signs indicating the bend;
- additional fuel tanks;
- how coaches respond to outbreaks of fire;
- smoke extraction in coaches;
- emergency evacuation of coaches.

2

Road signs indicating the bend



Since the accident, multi-chevron warning signs have been erected on the outside of the bend in both directions.

*Without issuing any formal recommendations, the **BEA-TT** has invited the body responsible for the roadway to study the possibility of limiting the maximum speed limit to **50 km/h** for this bend.*

Recommendation R 1 (Directorate General for Energy and Climate - DGEC):

Amend Article 13 of the decree of 19 July 1954 relating to the type-approval of motor vehicles in order to add to the list of significant conversions any addition of a tank of fuel of significant capacity not expressly foreseen by the manufacturer of the motor vehicle and update the technical instructions for vehicle inspection accordingly.

In addition, without making any formal recommendation, the BEA-TT invites road haulier associations to make their members aware of the need to install tanks on their vehicles in compliance with the technical rules for approval.

2

The burning behaviour of coaches

The vehicle caught fire extremely quickly, leaving very little time for the passengers to evacuate.

The **materials** used to fit out the passenger compartment of a coach must pass a number of **fire resistance tests**, examining their flammability and **the speed at which a fire progresses**, in accordance with UNECE Regulation No.118.

However, these requirements only require materials to be tested using heat sources at relatively **low temperatures**.

Moreover, **unlike other modes** of transport (train, aeroplane, boat, etc.) there are **no specific requirements** regarding the **toxicity** of gases produced, the **density** of fumes released or the **quantity** of heat emitted.

Recommendation R 2 (Directorate General for Energy and Climate - DGEC):

Within the framework of the revision of UNECE regulation no. 118, it has been proposed that the requirements concerning the fire resistance of materials used in the construction of vehicles be strengthened and that new requirements regarding the toxicity of the gases released by the combustion of these materials be introduced.

2

The smoke extraction of coaches

Without formulating any formal recommendation, the BEA-TT has brought to the attention of transport companies the usefulness of distributing information to passengers regarding the use of smoke extraction devices and emergency evacuation procedures to be followed, and has invited the FNTV to update its passenger safety cards (compiled in 2016) to include a description of what to do in the event of a fire breaking out in the coach's passenger compartment.

Measures should also be taken to permit rapid and automatic opening of smoke extraction devices so as to delay the invasion of the passenger compartment by toxic fumes to allow passengers more time to evacuate the vehicle.

Recommendation R 3 (Directorate General for Energy and Climate - DGEC):

Within the framework of the amendment of UNECE regulation no. 107, it is proposed that the requirements concerning the opening mechanisms of smoke extraction systems be strengthened in order to facilitate their opening.

Recommendation R 4 (Directorate General for Energy and Climate - DGEC):

Within the framework of the revision of UNECE regulation no.107, it is proposed that:

- **an emergency door positioned in the rear part of the vehicle be added. Failing this, extend the provisions of decree 2015-1170 of 22 September 2015 on the accessibility of rolling stock for regular intercity public road transport services for freely organised persons to all coaches.**
- **and/or reinforce the requirements for the opening mechanisms of emergency windows in order to make them manoeuvrable instantaneously to facilitate their use in the event of emergency evacuation**

Following the **collision**, the lights in the coach went off, plunging the passengers into **darkness**. While new vehicles are equipped with emergency lighting systems, it must be ensured that these provide **guide lighting** that is **powerful** enough to be effective in smoky conditions..

Recommendation R 5 (Directorate General for Energy and Climate - DGEC):

Strengthen the regulation of "emergency lighting systems" for coaches in order to ensure that the safety devices to be used for emergency evacuations and the vehicle's marker lights of the evacuation routes remain visible, especially if the passenger compartment becomes flooded with opaque fumes.



Bureau d'Enquêtes sur les Accidents de Transport Terrestre



Tour Pascal B

92055 La Défense cedex

Téléphone : 01 40 81 21 83

Télécopie : 01 40 81 21 50

bea-tt@developpement-durable.gouv.fr

www.bea-tt.developpement-durable.gouv.fr