



Lateral Protection Device

France – Evolution study on Regulation UNECE n° 73

●●● Structure

- ⇒ Accidentology analysis
- ⇒ Regulation context
- ⇒ International overview
- ⇒ Protection structures for motorcyclists
- ⇒ Protection device comparative analysis
- ⇒ Vehicles design
- ⇒ Test phase
- ⇒ Technical proposal

●●● Structure

- ⇒ Accidentology analysis
- ⇒ Regulation context
- ⇒ International overview
- ⇒ Protection structures for motorcyclists
- ⇒ Protection device comparative analysis
- ⇒ Vehicles design
- ⇒ Test phase
- ⇒ Technical proposal

●●● Accidentology analysis

✈ Accident conditions

- ✈ Last accident case was observed in France, 2014, a [motorcyclist](#) drive on highway between the left and the central lanes when he hurts a private car, falls on the ground and slips on the roadway [under the wheels of a semi-trailer](#) located on the right lane.
- ✈ This accident was a direct consequence of a lane switch by a car driver, from the left to the center lane, when the motorcyclist arrived on the same level.

✈ Main factors

- ✈ High speed differential between the motorcycle that was traveling around 70 kph and the car that was quite stationary.
- ✈ The motorcyclist's low detectability in a dark light conditions, in spite of the adapted turn signal switch on.
- ✈ Aggravation by the motorcyclist slide under a semi-trailer that was made possible by [a large space, although compliant with regulations, that was clear between the ground and the protection device](#) equipping this semi-trailer.

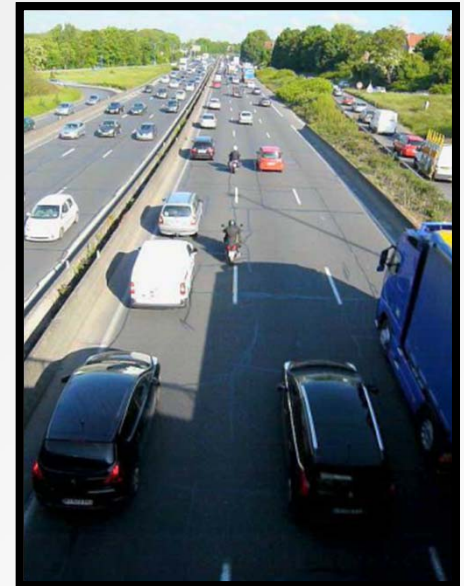

●●● Structure

- ⇒ Accidentology analysis
- ⇒ Regulation context
- ⇒ International overview
- ⇒ Protection structures for motorcyclists
- ⇒ Protection device comparative analysis
- ⇒ Vehicles design
- ⇒ Test phase
- ⇒ Technical proposal

●●● Regulation context

➤ Current requirements in Europe : UNECE n°73 series 01 of amendment

➤ Geometrical requirements on Y axis

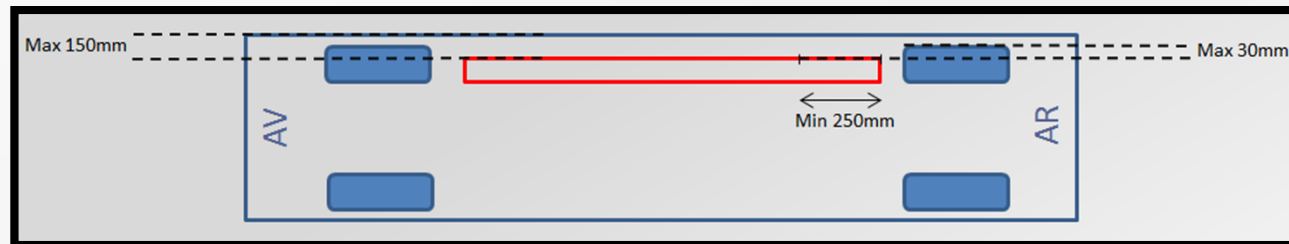

➤ Geometrical requirements on Z axis (depending on vehicle category)

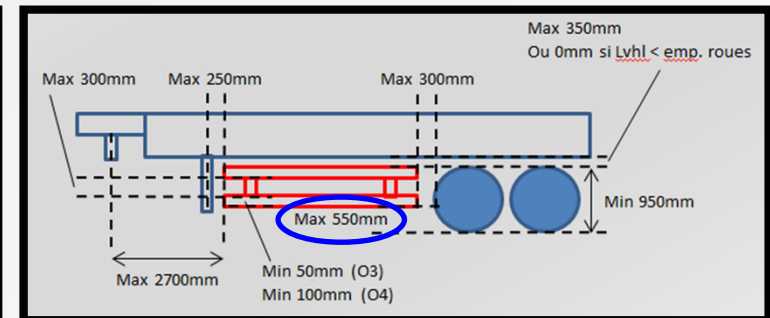
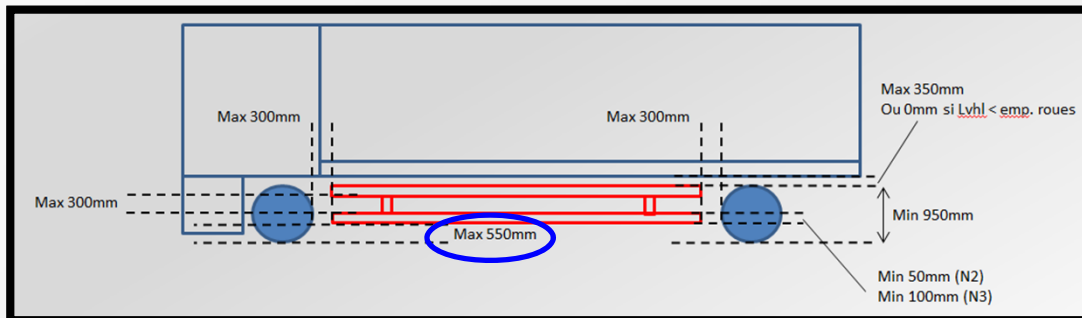

➤ Loading requirement under 1kN force application : displacement under 30mm or 150mm depending on the force application location

●●● Structure

- ⇒ Accidentology analysis
- ⇒ Regulation context
- ⇒ International overview
- ⇒ Protection structures for motorcyclists
- ⇒ Protection device comparative analysis
- ⇒ Vehicles design
- ⇒ Test phase
- ⇒ Technical proposal

●●● International overview

⇒ French statistics

- ⇒ Status including collision loadcases between 2 wheels motorized vehicles and heavy duty vehicles in 2011 (all kinematics) :
 - 0.6% of the total number of accidents, ie approximately 390 accidents (total 65 024)
 - 1.6% of fatalities were recorded, ie approximately **58 users killed** (total 3 647)
 - 0.4% of the injured, or approximately 325 injured (total 81,251)
 - 0.9% of the hospitalized injured, ie approximately 267 patients (total 29,679)

- ⇒ Even if this loadcase seems to be a minor one, **fatalities versus number of accident is high, around 15%**.

●●● International overview

⇒ Feedbacks from other countries

- ⇒ United Kingdom : loadcase considered as a minor one, without explicit statistic on it.
- ⇒ Netherlands : low feedbacks on accidentology but in addition to the dimensional specifications, the loading level seems to not be in adequation with a collision including a morotcyclist.
- ⇒ Belgium : low feedbacks on accidentology except an overview on side-impact collision with a heavy duty vehicle including at least one victim :

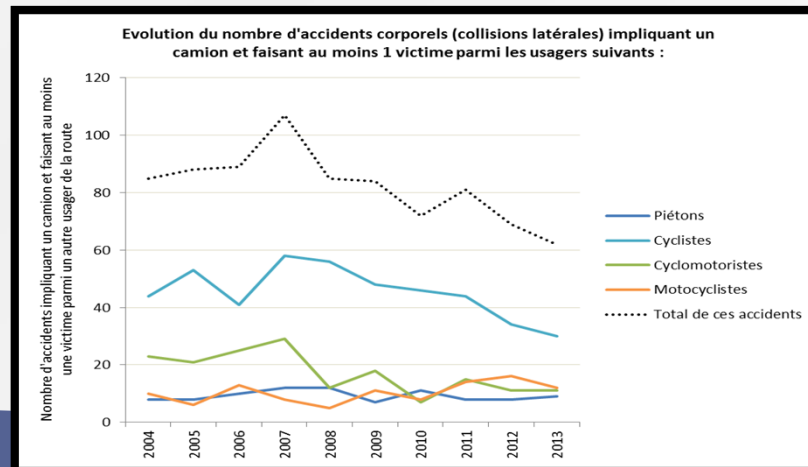

●●● International overview

⇒ Feedbacks from other countries

⇒ European Union : previous study for GSR phase 2 considering an efficiency increase (covering surface and ground clearance updates) based on accidentology feedbacks with cyclists users.

⇒ Japan : Similar UNECE n° 73 national requirements referenced in the "Safety Regulations for Road Vehicle" and associated delegated acts. The main dimensional requirements are as follows: the height of its lower edge is **450 mm or less above the ground** and the height of its upper edge is 650 mm or more above the ground.

Lateral Side-Guards (LAT)

HGVs and their trailers are presently required to be fitted lateral side-guards to provide protection to pedestrians and cyclists in collisions with the side of such vehicles, reducing the likelihood of them being run over. However, the current legislative text allows for broad exemptions to fitting these structures; therefore action has now been taken at the UNECE level to improve the relevant legislation (UN Regulation No. 73).

Make O2 series of amendments to R73 mandatory for N2, N3, O3 and O4 vehicles including certain types of vehicles designed and constructed for special purposes:

- 01/09/2020 new approved types
- 01/09/2022 new vehicles

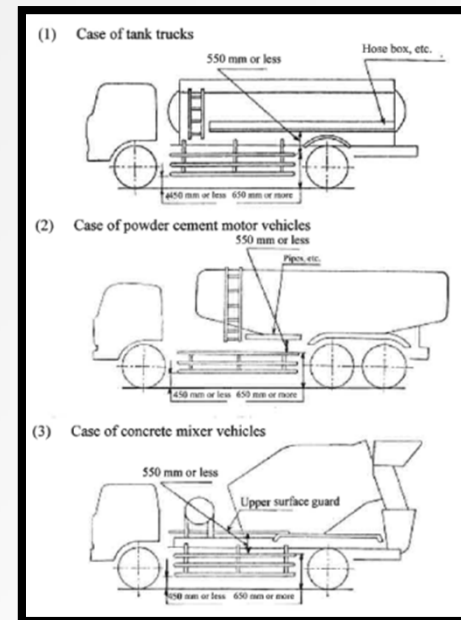

●●● International overview

✈ Feedbacks from other countries

- ✈ Cana / US : There is no federal requirement to equip heavy-duty vehicles with lateral protection because of a high variety of vehicle design, their use, cost, maintenance and climatic conditions. Studies are underway but are more oriented towards requirements in terms of detection of other users around the vehicle (blind spot).

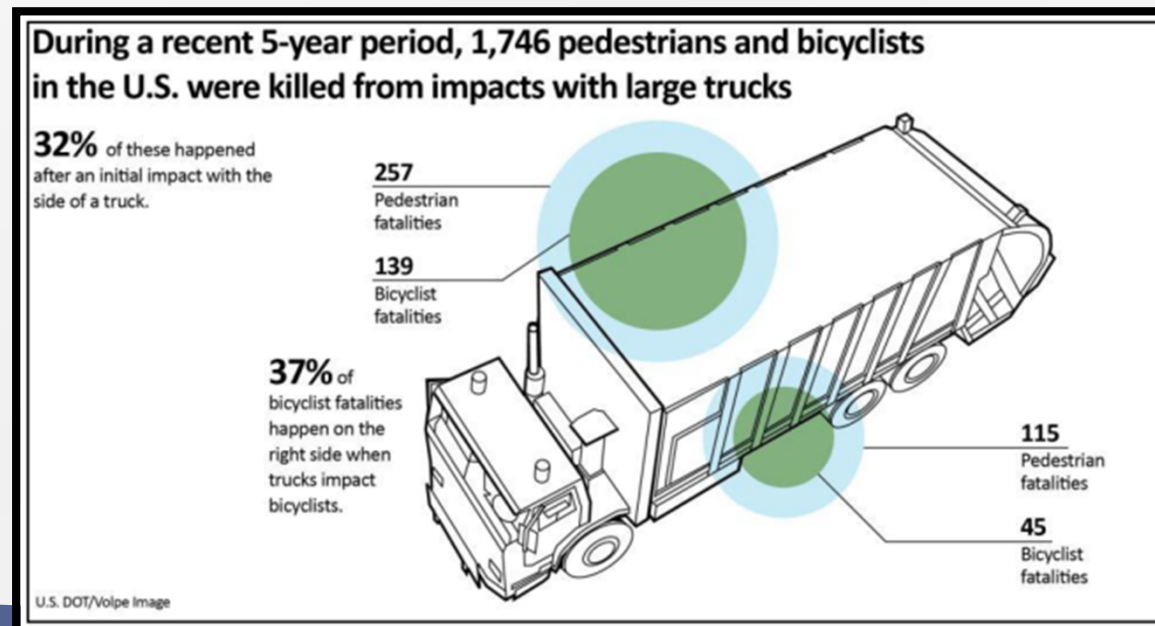

●●● International overview

➤ Feedbacks from other countries

- US : Study for Cambridge safer truck initiative in 2016 to improve vulnerable road users safety in the extended city. As a conclusion, a significant safety increase can be brought by fulfilling the following specifications :
 - Maximum ground clearance at 350mm
 - Loading resistance to 2kN force (30mm or 150mm maximum deformation)

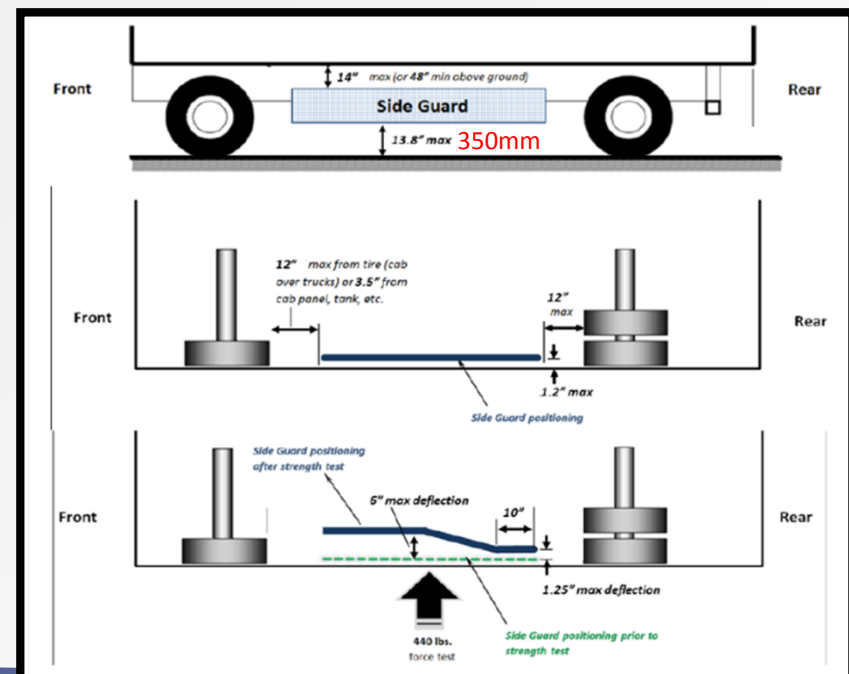
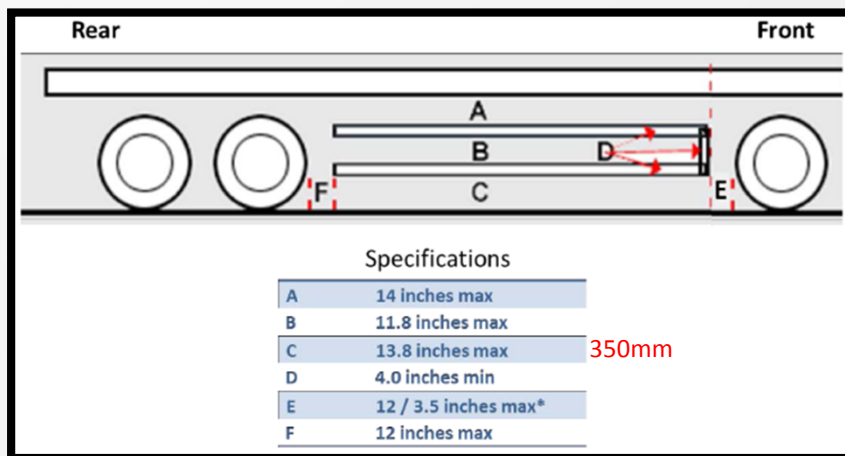

●●● Structure

- ⇒ Accidentology analysis
- ⇒ Regulation context
- ⇒ International overview
- ⇒ Protection structures for motorcyclists
- ⇒ Protection device comparative analysis
- ⇒ Vehicles design
- ⇒ Test phase
- ⇒ Technical proposal

●●● Protection structure for motorcyclists

- XP CEN/TS 1317-8 : Road restraint systems for motorcycles to reduce the severity of impact in the event of a collision with safety barriers
- In order to reduce the consequences of an impact between a two-wheeled motor vehicle and a barrier, it may be necessary to install an additional specific structure above the regular barrier.
- Some studies indicating that [the "slip" configuration is predominant](#) have led to the development and use, in some European countries, of test procedures evaluating the systems with respect to this loadcase.



●●● Protection structure for motorcyclists

⇒ Test principle

- ⇒ The full-scale impact test consists of launching an equipped ATD (Anthropomorphic Testing Device) at a given speed against a barrier equipped with a Motorcycle Protection System (SPM) in a suitable test area.
- ⇒ At the moment of impact, the DAE (50mm Hill dummy) slips while its back and legs are in contact with the ground.
- ⇒ 3 test configuration: impact at the center of the support, offset from the support and at mid-range with an angle of 30° with respect to the device and 2 speeds, 60 kph and 70 kph.

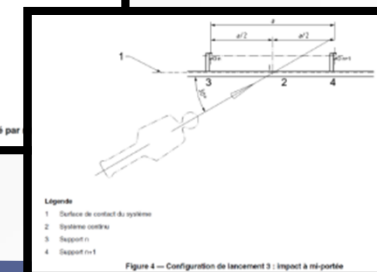
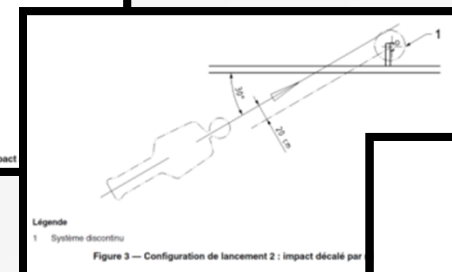
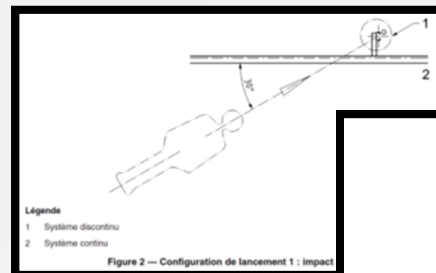

●●● Protection structure for motorcyclists

⇒ Test conformity

- ⇒ Compliance with requirements is assessed through the following biomechanical criteria: Head Injury Criteria, Neck shear force, Axial neck tension, axial compression of neck, neck moment around X and neck moments around Y (extension and flexion)

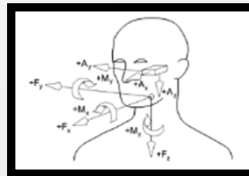

		Valeurs maximales admissibles					
		Cou					
Niveau de sévérité	Tête	F _x N	F _{reaction} N	F _{compression} N	M _{ky} N.m	M _{ky extension} N.m	M _{ky flex} N.m
		HIC ₁₅					
I	650	Figure 7	Figure 8	Figure 9	134	42	190
II	1 000	Figure 10	Figure 11	Figure 12	134	57	190

- ⇒ The height of the SPM is directly related to the geometry of the ATD used during the tests (Hill 50th pc - Mass 80kg)

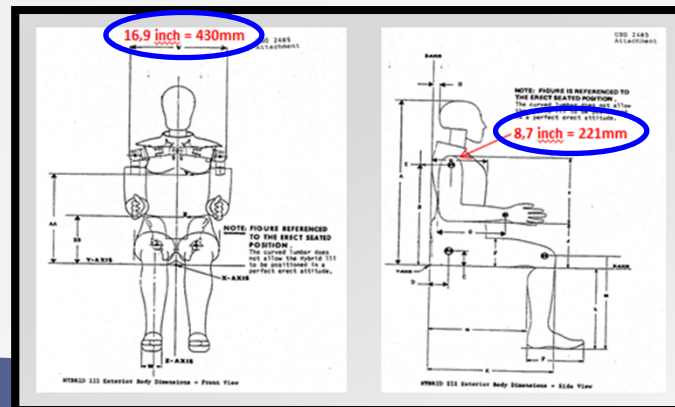

●●● Protection structure for motorcyclists

- Loading levels (Public thesis university Lyon 2016 “Evaluation and modelling of restraints for motorcyclists) – Injury criticality
 - Improved attention to the case of impact accidents with road restraints indicates that torso injuries are the most serious injuries compare to other parts of the body.
 - Evaluations of impact forces Fy cou ~ 10kN and Fy thorax ~ 3kN for impact at 60kph and 30 °

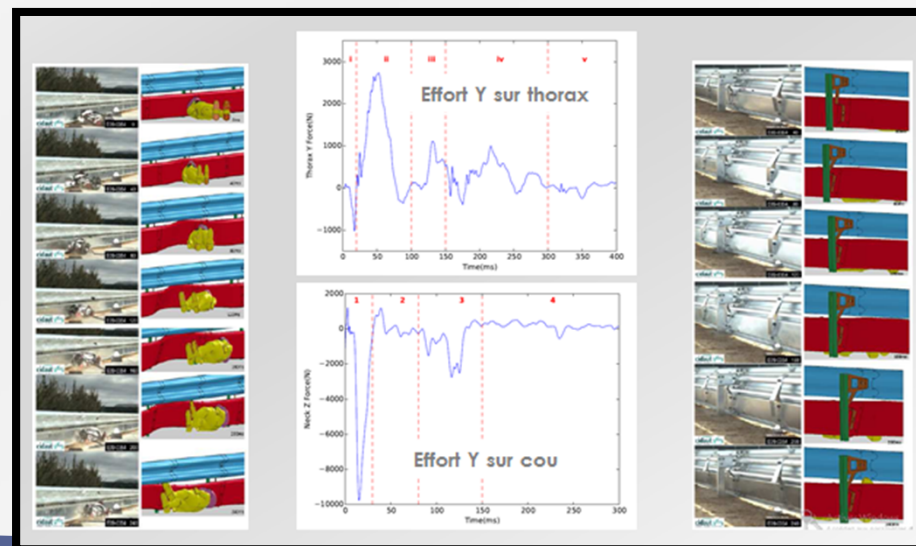

●●● Structure

- ⇒ Accidentology analysis
- ⇒ Regulation context
- ⇒ International overview
- ⇒ Protection structures for motorcyclists
- ⇒ Protection device comparative analysis
- ⇒ Vehicles design
- ⇒ Test phase
- ⇒ Technical proposal

●●● Protection device comparative analysis

➤ Regulation UNECE n° 58 on rear underrun protective device

- Text intended to ensure a minimum level of protection for the occupants of a light vehicle in the event of an impact on the rear of a heavy goods vehicle (high loading performance level between 5t and 10t)
- The severity of injuries is related to 2 main factors: kinetic energy of the light vehicle during the impact and the structural interaction between the front of the light vehicle and the rear of the heavy vehicle (max ground clearance at 550mm).

➤ Regulation UNECE n° 93 on front underrun protective device

- Text intended to ensure a minimum level of protection for the occupants of a light vehicle in the event of a frontal impact with an N2 or N3 vehicle (high loading performance level between 80kN and 160kN)

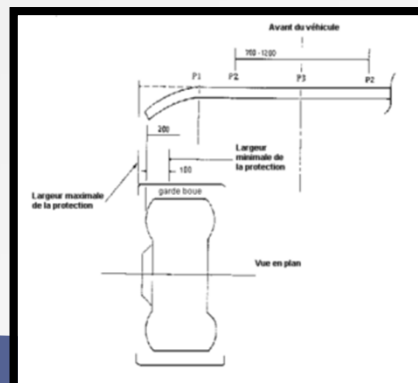

●●● Structure

- ⇒ Accidentology analysis
- ⇒ Regulation context
- ⇒ International overview
- ⇒ Protection structures for motorcyclists
- ⇒ Protection device comparative analysis
- ⇒ Vehicles design
- ⇒ Test phase
- ⇒ Technical proposal

Vehicles design

Dimensional constraints

- Dimensional constraints integrated during the vehicle development phase is mainly based on the constraints of ISO 612: 1978 dealing with the "Dimensions of cars and towed vehicles".
- By analogy with the studies carried out for the last series of amendments to UNECE Regulation No. 58 (leakage angle), the minimum value to be considered for the (half) ramp angle to ensure an easy traffic is 8 °.
- A non-exhaustive analysis of the other categories of vehicles shows that vehicles using the same traffic lanes as those used by vehicles falling within the scope of UNECE Regulation No.73 have much lower ground clearances.

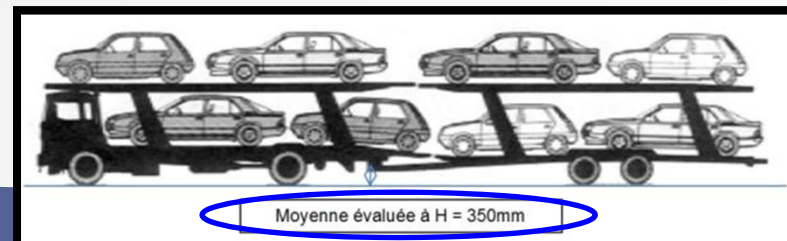
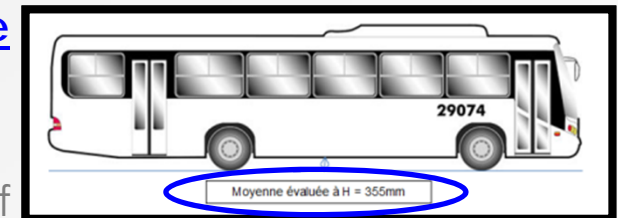
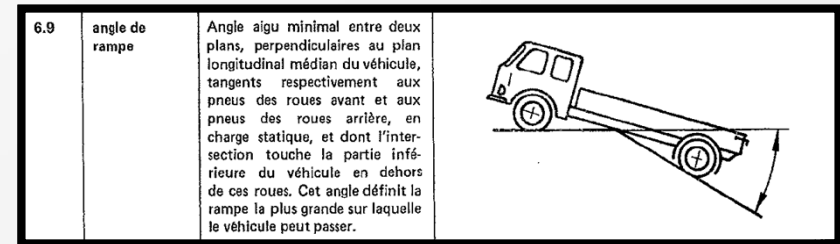

●●● Structure

- ⇒ Accidentology analysis
- ⇒ Regulation context
- ⇒ International overview
- ⇒ Protection structures for motorcyclists
- ⇒ Protection device comparative analysis
- ⇒ Vehicles design
- ⇒ Test phase
- ⇒ Technical proposal

●●● Test phase

⇒ Phase 1 : Tests performed - Evaluation of a separate unit resistance to a loading up to 3kN and quantification of the displacement observed.

⇒ Loading applied on pillar with 3m gap between pillars.



Max. disp. :
55,3mm

⇒ Loading applied in the middle between pillars with 1,5m gap between pillars.



Max. disp. :
76,7mm

⇒ Loading applied outside 350mm from the last pillar with 1,5m gap between pillars.



Max. disp. :
123,5mm

●●● Test phase

⇒ Phase 1 : Analysis

- ⇒ The current structures, without any reinforcement, can be used to fulfill loading requirements increased at 3kN, using implementation adjustments (gap between pillars).
- ⇒ Without device design update, a decrease (in the order of -50%) of the distances between pillars could allow to achieve the targeted performance level for the device resistance (breaking avoidance).
- ⇒ The front and rear extremities also require a decrease of current distance from the last pillar in order to improve the device resistance, in association with a reduced distance between the connecting elements (breaking avoidance).

●●● Test phase

➤ Phase 2 : Tests performed - Evaluation of vehicle integrated unit resistance to a loading up to 3kN and quantification of the displacement observed.

➤ Loading applied in the middle between pillars with 2,65m gap between pillars.

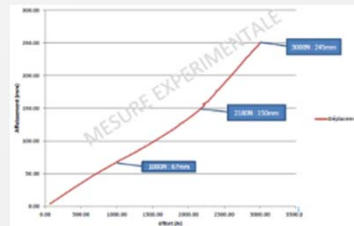

Max. disp. :
245mm

➤ Loading applied on pillar with 2,65m gap between pillars.

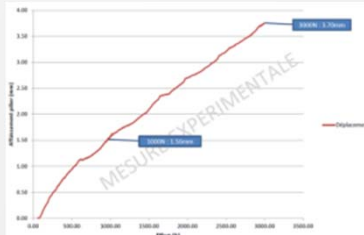

Max. disp. :
3,7mm

➤ Loading applied outside 400mm from the last pillar with 2,65m gap between pillars.

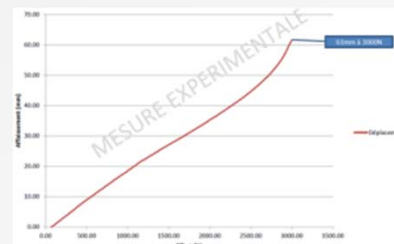

Max. disp. :
61mm

●●● Test phase

⇒ Phase 2 : Analysis

- ⇒ The evaluated structures without any reinforcement can be used to achieve targeted loads at 3kN without any particular update vehicle implementation.
- ⇒ Only the front and rear extremities from the last pillar would require a slight decrease (of the order of -10%) without update on the distance between the connecting elements (breaking avoidance).
- ⇒ On the basis of these results, an update of the current requirements could be investigated with the application of a coefficient 3 on both loading performance level and the required maximum displacement levels.

●●● Structure

- ⇒ Accidentology analysis
- ⇒ Regulation context
- ⇒ International overview
- ⇒ Protection structures for motorcyclists
- ⇒ Protection device comparative analysis
- ⇒ Vehicles design
- ⇒ Test phase
- ⇒ Technical proposal

●●● Technical proposal

⇒ Geometrical constrains

⇒ This proposal deals with the requirements for the installation of protective devices on vehicles, integrating the following parameters:

- Dimensional thorax manikin HIII 50th pc width
- Dimension of existing devices on the market
- International studies and other regulations
- Compatibility with current road devices

⇒ The dimensional principle proposed is based on the ramp angle, considering the intersection point "I" within the wheelbase, with the following requirements along the Z axis of the vehicle reference:

- If $I \leq 350\text{mm}$ then the ground clearance can be 350mm max.
- If $350\text{mm} < I \leq 450\text{mm}$ then the ground clearance is I
- If $450\text{mm} < I$ then the ground clearance is 450mm max.

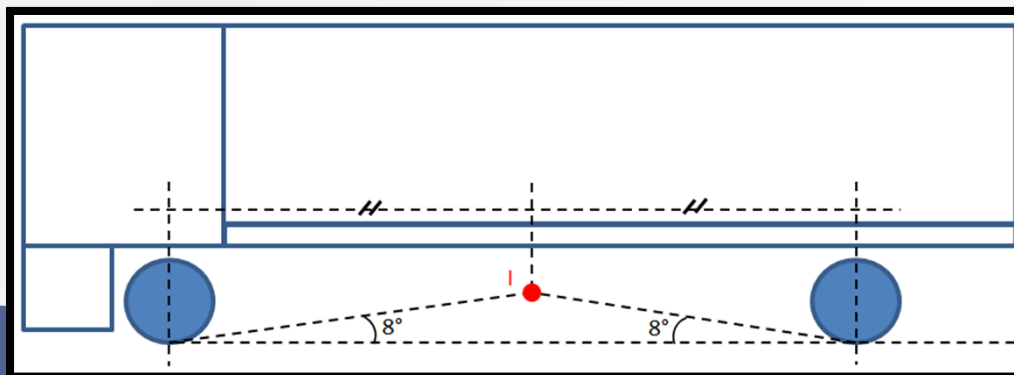

* To be adapted for trailer

●●● Technical proposal

⇒ Geometrical constrains

⇒ Associated distances adjustment

- Height conservation (50 / 100mm).
- Max. gap between devices at 400mm.
- Vehicle chassis distance to top edge of the device at 450mm max.
- Upper edge of the device shall not be less than 850 mm above the ground.
- Exception to be kept for ground clearance of G category

⇒ Loading and displacement constrains

- ⇒ While the current 1kN solicitation of UNECE Regulation No. 73 comply with an adapted protection for pedestrians or cyclists impacts, it appears to be too limited when a motorcycle driver impacts the device.

●●● Technical proposal

⇒ Loading and displacement constrains

- ⇒ Target is to encourage a device behavior still in the material elastic area, including linear strains.

- ⇒ In this way, a device close to the required limit under the new loading will stay close to the limit under current loading level : keep the same protection level for low and for high loadings.

- ⇒ A parallel with the design of motorcycle road restraints and especially of the major criteria of injuries (thorax), the following loading requirements could be updated :
 - Application of a force of [3kN](#) perpendicular to the device (as currently defined).
 - Max. strain under loading at [90mm](#) over the 250mm most backwards part.
 - Max. strain under loading at [450mm](#) on the other parts.

UTAC CERAM



Thanks for your attention.