

**REPORT FOLLOWING  
TECHNICAL INVESTIGATION  
into the collision (and resulting fire)  
between a coach and a HGV  
that occurred on October 23rd 2015  
on Departmental Road No 17  
near the town of Puisseguin  
(South-West of France)**

**July 2017**



**Land Transport Accidents  
Investigations Bureau**

Case n° BEATT-2015-014

**Report following the technical investigation  
into the collision (and resulting fire)  
between a coach and a HGV  
that occurred on October 23<sup>rd</sup> 2015  
on Departmental Road n°17  
near the town of Puisseguin  
(South-West of France)**

# Bordereau documentaire

Report commissioned by: Ministry for an Ecological and Solidarity Transition (MTES)

Report compiled by: Land Transport Accidents Investigations Bureau (BEA-TT)

Document Title: Report following the technical investigation into the collision (and resulting fire) between a coach and a HGV on October 23rd 2015 on Departmental Road 17 near Puisseguin (33)

IRSN N°: EQ-BEAT--17-6--FR

Suggested keywords: coach, fire

Photo and graphic design credits:

- AF: AFHYMAT;
- BEA-TT: Land Transport Accidents Investigations Bureau
- CL: Christophe Ledon, accident examiner;
- EV: EvoBus France;
- FB: Francis Bréville, automobile expert;
- Gend. : gendarmerie (police);
- IV: IVECO;
- XG: Xavier Gargasi, fire expert.

### **Legal Notice**

The technical investigation featuring in this report was carried out in accordance with Articles L. 1621-1 - 1622-2 and R. 1621-1 - 1621-26 of the French Transport Code, pertaining in particular to technical inquiries carried out following a land transport accident or incident.

The sole objective of this investigation is to prevent future accidents from occurring by determining the circumstances and causes of the event and establishing relevant safety recommendations. The report does not aim to determine responsibility for the accident.

As a result, the use of this report for purposes other than accident prevention may lead to erroneous interpretations of its contents.



# TABLE OF CONTENTS

<b>GLOSSARY</b> .....	<b>11</b>
<b>INCIDENT SUMMARY</b> .....	<b>13</b>
<b>1 - IMMEDIATE ANALYSIS AND LAUNCH OF OFFICIAL INVESTIGATION</b> .....	<b>15</b>
1.1 - Circumstances of the accident.....	15
1.2 - Death and injury toll.....	15
1.3 - Launch and organisation of the investigation.....	15
<b>2 - BACKGROUND TO THE ACCIDENT</b> .....	<b>17</b>
2.1 - Weather Conditions.....	17
2.2 - Departmental Road n°17.....	17
2.2.1 -Road characteristics.....	17
2.2.2 -Road adhesion measurements.....	19
2.2.3 -Traffic and Accident Rates.....	19
<b>3 - SUMMARY OF INVESTIGATIONS CARRIED OUT</b> .....	<b>21</b>
3.1 - Situation at the scene as encountered by emergency services.....	21
3.1.1 -Position and condition of the vehicles.....	21
3.1.2 -Tyre tracks found on the road surface.....	22
3.1.3 -Infrastructural Damage.....	24
3.2 - Witness Statement Summaries.....	24
3.2.1 -Witness statement from the coach driver.....	24
3.2.2 -Witness statements from coach passengers.....	25
3.2.3 -Witness statements from motorists present at the scene of the accident.....	27
3.3 - The coach.....	28
3.3.1 -Organisation of the excursion.....	28
3.3.2 -The coach driver.....	28
3.3.3 -Technical characteristics of the coach.....	29
3.3.4 -Expert assessment of the coach.....	38
3.4 - The articulated lorry.....	42
3.4.1 -The driver of the articulated lorry.....	42
3.4.2 -Technical characteristics of the tractor unit.....	44
3.4.3 -Modifications made to the tractor unit following its factory release.....	49
3.4.4 -Technical characteristics of the semitrailer.....	55
3.4.5 -Assessment of the Tractor Unit.....	56
3.4.6 -Expert analysis of the semitrailer and its components.....	61
3.5 - Kinematic reconstruction of the accident.....	63
3.5.1 -Final position of vehicles and tyre tracks on road surface.....	64
3.5.2 -Identification of impact points and directionality.....	65

3.5.3 -Vehicle 3D Modelling.....	66
3.5.4 -Results.....	66
3.6 - Outbreak and spread of the fire.....	67
3.6.1 -Fuel supply sources.....	68
3.6.2 -The heat source at the origin of the blaze.....	73
3.6.3 -The hypothesis concerning what triggered the fire and caused it to spread.....	73
3.7 - Current regulations for public transit vehicles in terms of layout, fire risk and design of exits.....	74
3.7.1 -Tanks and auxiliary liquid fuel tanks.....	76
3.7.2 -Prevention of fire risks in coaches.....	76
3.7.3 -Design of coach exits.....	76
3.7.4 -Interior lighting and emergency lighting for coaches.....	77
3.8 - Emergency evacuation procedure.....	77
3.9 - Similar accidents.....	78
<b>4 - ANALYSIS OF THE COURSE OF THE ACCIDENT AND RESCUE OPERATIONS.....</b>	<b>81</b>
4.1 - The route of the vehicles before the accident.....	81
4.1.1 -The route of the articulated lorry.....	81
4.1.2 -The route of the coach.....	81
4.2 - The collision and the ignition of the fire.....	81
4.3 - Evacuating the coach.....	82
4.3.1 -Notification of emergency services.....	82
4.3.2 -Assessment and location of victims.....	82
4.3.3 -Assessment of the means of assistance implemented.....	83
<b>5 - ANALYSIS OF CAUSES AND ASSOCIATED FACTORS, PREVENTIVE GUIDELINES.....</b>	<b>84</b>
5.1 - The pattern of causes and associated factors.....	84
5.2 - The signing for the bend.....	86
5.2.1 -Reminder of the findings.....	86
5.2.2 -Analysis.....	86
5.3 - Additional fuel tanks.....	87
5.3.1 -Reminder of the findings.....	87
5.3.2 -Analysis.....	87
5.4 - The burning behaviour of coaches.....	88
5.4.1 -Reminder of the findings.....	88
5.4.2 -Analysis.....	88
5.5 - The smoke extraction and evacuation of coaches.....	90
5.5.1 -Reminder of the findings.....	90
5.5.2 -Analysis.....	90
<b>6 - CONCLUSIONS AND RECOMMENDATIONS.....</b>	<b>95</b>
6.1 - Causes of the accident.....	95
6.2 - Preventive guidelines.....	95



Appendix 3: Aerial view of RD 17 in the area of the accident.....	101
Appendix 4: Cross-sectional horizontal and vertical alignment of RD 17 at the accident site .....	102
Appendix 5: Accident frequency rate on the RD 17 between 2010 and 2015.....	105
Appendix 6: Description of the coach's heating and air conditioning systems.....	106
Appendix 7: Extract from the safety data sheet for refrigerant R134a.....	110
Appendix 8: Extract from the safety data sheet for Glystantin G48.....	111
Appendix 9: Excerpts from the "TOTAL Diesel Premier" fuel safety data sheet.....	112
Appendix 10: Coach Passenger Safety Awareness Booklet published in 2016 by the FNTV.	114



# Glossary

- **ABS:** Anti-lock braking system
- **ABS:** Acrylonitrile butadiene styrene, a thermoplastic polymer that is often used in automotive construction.
- **AGVW:** Authorised Gross Vehicle Weight
- **DR:** Departmental Road
- **FNTV:** National federation of passengers transport
- **GVWR:** Gross Vehicle Weight Rating
- **HGV:** Heavy Goods Vehicle
- **IISR:** Interministerial Directive on Road Signs
- **MRP:** Map Reference Point
- **SCR:** Selective Catalytic Reduction – a technique used to reduce emissions of nitrogen oxide from internal combustion engines.



# Incident Summary

On October 23rd 2015, at around 7.30am, near the town of Puisseguin in the Gironde department of France (33), an articulated lorry (consisting of a tractor unit and an empty wood trailer) with two people on board, travelling on the Departmental Road number 17 towards the town of Puisseguin, jack-knifed when navigating a right-hand bend and passed into the opposite lane, colliding with a coach carrying 49 people which was travelling in the opposite direction.

A fire broke out immediately after the crash and engulfed both vehicles.

The accident resulted in the deaths of 43 people (41 coach passengers and the two people travelling in the HGV), and caused injuries to 8 others who were able to escape from the coach (the driver and 7 passengers).

The direct cause of the accident was the loss of control of the HGV as it was navigating a tight right bend, causing the vehicle to swerve into the left hand-lane and collide with a coach travelling in the opposite direction.

A fierce blaze broke out immediately after the collision. The coach was quickly engulfed in flames and filled with toxic black smoke.

Several factors played a role in the accident's high death toll:

- the presence of an additional, non-regular diesel tank installed behind the cabin of the tractor unit;
- the nature of the materials used for the coach's interior fittings, their flammability and the toxicity of the gases released via their combustion;
- the passengers' difficulty in activating the coach's smoke extraction devices;
- the passengers' difficulty in using the coach's two entrances and emergency exits;
- the absence of light inside the coach following the collision.

In light of these elements, the BEA-TT has drawn up, for the attention of the Ministry of Transport's Directorate of Energy and Climate, five recommendations regarding:

- the installation inspections for additional fuel tanks on vehicles;
- the improved fire-resistance of materials used in vehicle construction, and the introduction of new industrial standards regarding the toxicity of gases released by the combustion of these materials;
- the improvements to the opening mechanisms for smoke extraction devices, in order to make them easier to use;
- the addition of emergency doors at the rear end of such vehicles, or failing this, extending the provisions of Decree n° 2015-1170, issued on September 22nd 2015 (pertaining to accessibility in vehicles designated for use in providing inter-urban public transport services) to all buses and coaches, and/or improving industry standards regarding the opening mechanisms of emergency exit windows in order to make them instantly manoeuvrable and easier to use in the event of an emergency evacuation of the vehicle.

- The reinforcement of existing legislation regarding “emergency lighting systems” for coaches, so that safety equipment for emergency evacuations (and emergency lighting used to indicate vehicle evacuation routes) remain visible, especially in cases where the vehicle’s interior has become filled with opaque smoke.

*In addition, without formulating any formal recommendations, the BEA-TT:*

- *has invited the roadways authority to study the possibility of reducing the maximum speed limit to 50 km/h on this corner;*
- *has invited trade union bodies representing HGV drivers to make their members aware of the importance of respecting approved technical rules when installing fuel tanks;*
- *has invited the FNTV to complete the safety leaflet introduced in 2016 which indicate the safety rules to be respected on board in the coach, as well as emergency evacuation rules, by describing what to do in the event of a fire breaking out in the passenger compartment of the coach.*

# **1 - Immediate analysis and launch of official investigation**

## **1.1 - Circumstances of the accident**

On October 23rd 2015, at around 7.30am, near the town of Puisseguin in the Gironde department of France (33), an articulated lorry (consisting of a tractor unit and an empty wood trailer) with two people on board, travelling on the Departmental Road number 17 towards the town of Puisseguin, jack-knifed when navigating a right bend and passed into the opposite lane, colliding with a coach carrying 49 people which was travelling in the opposite direction.

A fire broke out immediately after the crash and engulfed both vehicles.

## **1.2 - Death and injury toll**

The accident resulted in the deaths of 43 people (41 coach passengers and the two people travelling in the HGV), and caused injuries to 8 others (the driver and 7 passengers of the bus).

## **1.3 - Launch and organisation of the investigation**

In light of the circumstances of the accident, the Director of the Land Transport Accidents Investigations Bureau (BEA-TT) opened a technical investigation on the same day the accident occurred (October 23rd 2015), under the provisions of Articles L. 1621-1 - L. 1622-2 of the French Transport Code.

BEA-TT investigators were rapidly deployed to the scene of the accident. There they met local magistrates and police officers responsible for the legal inquest into the accident.

They were given access to the vehicles, which had been sealed off as official evidence.

They were also given access to the judicial case files and to reports from four legal experts commissioned in October 2015, as well as the main administrative and technical documents necessary for their analysis.

They were unable to obtain copies of certain administrative and technical documents having been placed under seal. These pertain to the installation of the additional fuel tank behind the cabin of the tractor unit, as well as certain original copies of photographs taken by judicial investigators and a fire expert at the scene of the accident, which were also necessary to their analysis. Regarding the photographs in particular, the investigators were only able to work using their own printed reproductions.





## 2 - Background to the accident

### 2.1 - Weather Conditions

The last weather report issued before the accident by the nearest weather station (in St Emilion, roughly 7 kilometers from the crash site) was generated at 7am on the morning of October 23rd 2015, and indicated dry conditions with a temperature of 11.7°C.

Weather reports from the previous evening indicated a very slight chance of rain.

At the time the accident occurred it was before dawn, it was not raining and there was no fog, but the road surface was wet due to its being located in a wooded area.

### 2.2 - Departmental Road n°17

#### 2.2.1 - Road characteristics

The Departmental Road n°17 is a 52km stretch of road, running between Departmental Road n°910 (from the hamlet of “La Guirande” to the north) and Departmental Road n°672 (connecting near the village of Sauveterre-de-Guyenne to the south).

The accident occurred at MRP23+700, roughly 1 km south of Puisseguin.

This stretch of the Departmental Road follows a series of bends through wooded areas (cf. maps of the area and aerial photos in Appendices 2 and 3).

Drivers are made aware of the bends ahead of time through the presence of “A1”<sup>1</sup> road signs, which in accordance with regulations<sup>2</sup> were present around 150m before the series of bends on the coach’s side of the road, and around 110m from the series of bends in the other direction.



(CL photo)

**Figure 1: View of the “A1d” road sign situated ahead of the series of bends in the direction being travelled by the HGV**



(CL photo)

**Figure 2: View of the “A1c” road sign situated ahead of the series of bends in the direction being travelled by the coach**

1 “A1” sign: indicates a series of bends in succession

2 Outside urban areas, these signs must be erected between 100m and 200m before the danger zone, as close to 150m as possible.

The lorry came off the road while travelling around a right bend in this section of the road.

The bend runs slightly uphill in the direction the articulated lorry was travelling. The bend has an average radius of 55m. It is preceded by a slight left bend with no outer road markings.

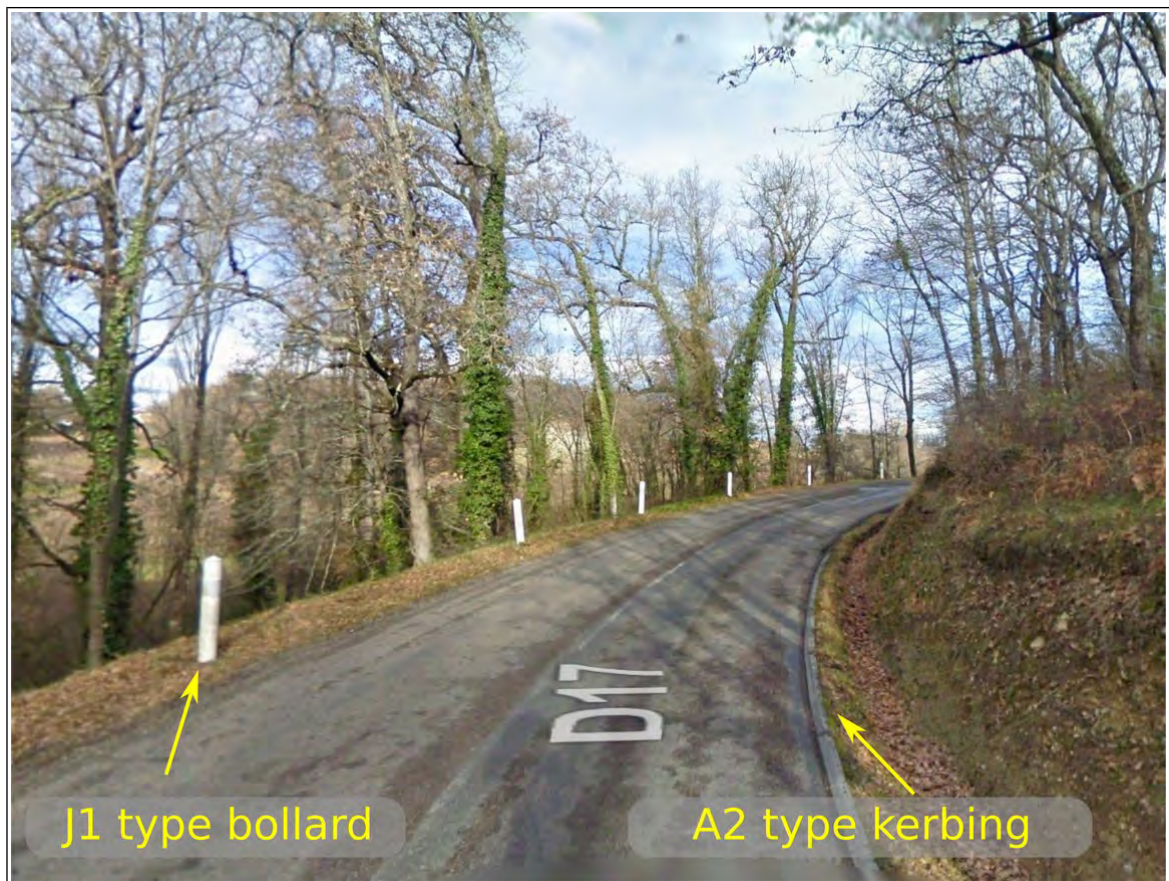
The road has an incline of between 4 and 6% towards the bend's interior. Appendix 4 of this report features a plan-view diagram and a number of profile diagrams for this section of the road.

The road is 6m wide and has two lanes. It is covered with a surface coating and bordered by grassy banks. The outside of the bend is marked by "J1" white plastic bollards positioned along the verge.

The two lanes are demarcated via a "T3" broken white line running along the middle of the road, which is faded and not easily visible.

The inside of the bend is separated from the verge by "A2" kerbing<sup>3</sup>.

The bank running along the inside of the bend makes it more difficult to read the bend, while also limiting the visibility of oncoming vehicles.



(Street view photo )

**Fig. 3: View of the bend where the accident occurred from the perspective of the lorry.**

This section of the road has slight ruts and the surfacing is worn in places due to the impact of vehicle wheels.

<sup>3</sup> "A2" kerbing: passable kerbing running along the verge.

Additionally, the bend's characteristics (road 6 metres wide, turn radius of 55m) make it particularly difficult for heavy vehicles to navigate successfully.

### **2.2.2 - Road adhesion measurements**

Measurements of road adhesion levels were carried out in late October 2015 on the DR 17 between Puisseguin and Saint-Genès-de-Castillon, near the site of the accident and on both lanes of the road.

The results obtained on the lane used by the lorry involved in the accident were deemed satisfactory, though less positive results were reported in certain places. This lack of consistency may be due to the presence of water or road surface contaminants (such as dead leaves) or the ruts observed in certain places.

### **2.2.3 - Traffic and Accident Rates**

The average daily traffic for the Departmental Road number 17, according to the most recent data prior to the accident (from November 5th - November 13th 2014) for MRP 27+600 around the area of Saint-Genès-de-Castillon, was 2,956 vehicles, of which 5.65% were heavy vehicles (these figures include traffic travelling in both directions).

There were no active traffic restrictions in the area, and the maximum speed limit was 90 km/h.

Between 2010 and 2015, along the 26 km-long section of the RD 17 running between Coutras and Castillon-la-Bataille, 7 accidents causing bodily harm were recorded, causing a total of two deaths and seven hospitalisations.

The details and locations of these 7 accidents are included in Appendix 5 of this report.





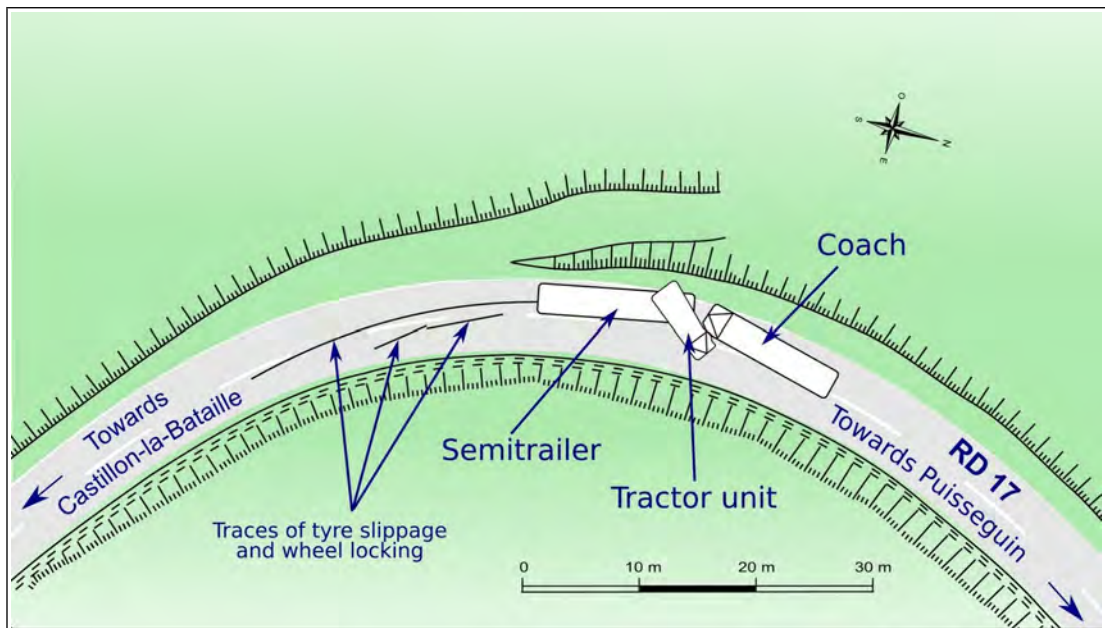
### 3 - Summary of Investigations carried out

#### 3.1 - Situation at the scene as encountered by emergency services

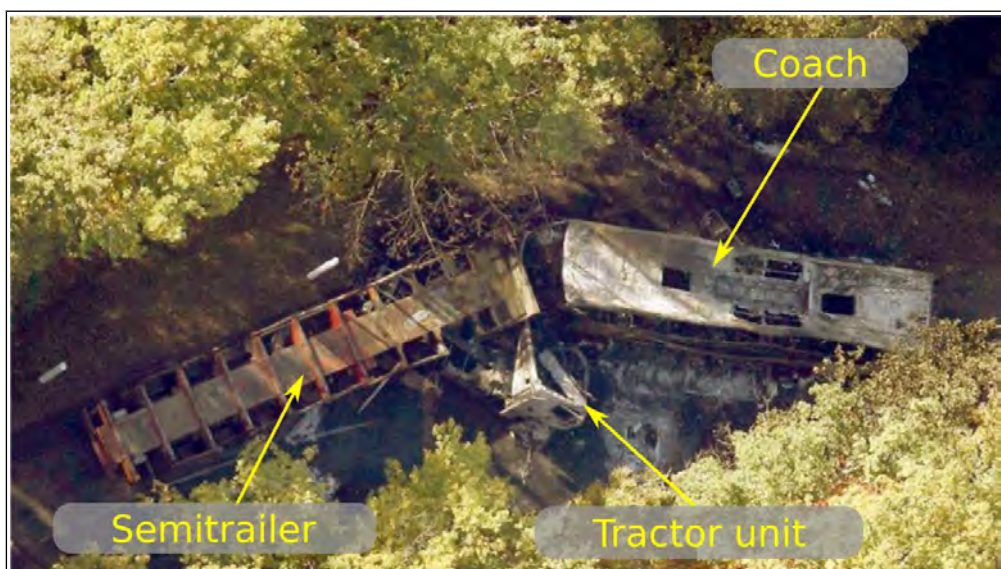
##### 3.1.1 - Position and condition of the vehicles

The diagram and photographs in figures 4 to 7 below indicate the respective positions of the vehicles involved in the October 23rd accident, as they were found by emergency services arriving at the scene.

The coach was immobilised on the road along the verge to the right of its lane. The lorry was immobilised in a jack-knife position along the same verge, in the opposite direction, with the front left of the vehicle resting against the front left of the coach.

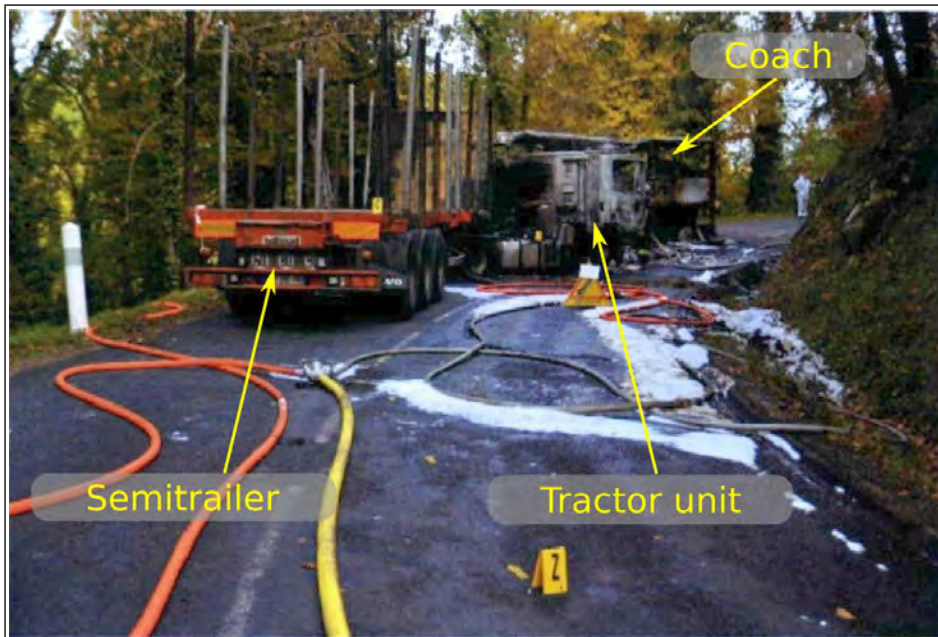


**Figure 4: Position of the vehicles upon the arrival of emergency services**



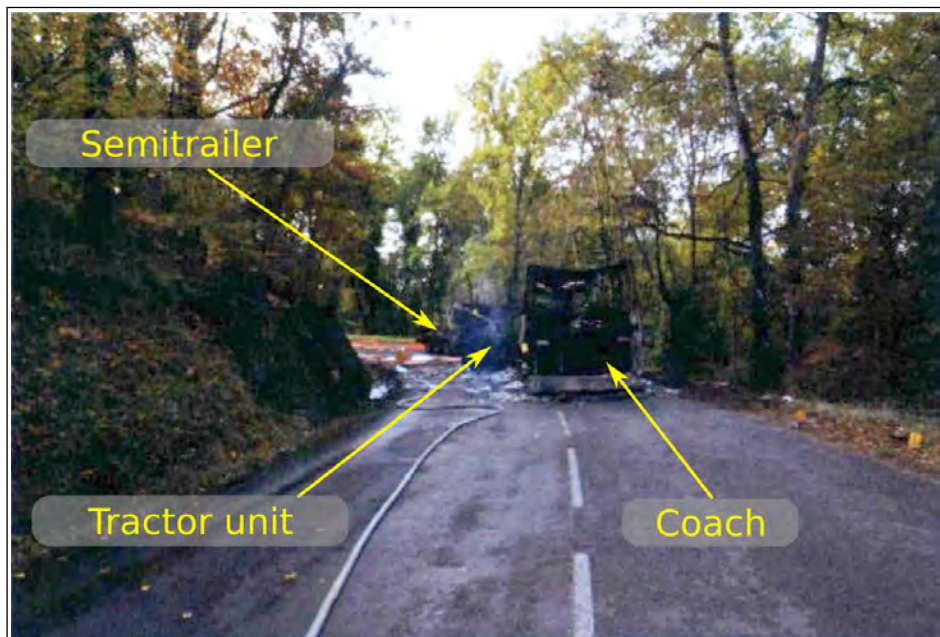
(police photo)

**Figure 5: Aerial view of the position of the vehicles following the collision**



(police photo)

**Figure 6: View (from the direction in which the articulated lorry was travelling) of the position of the vehicles following the collision**



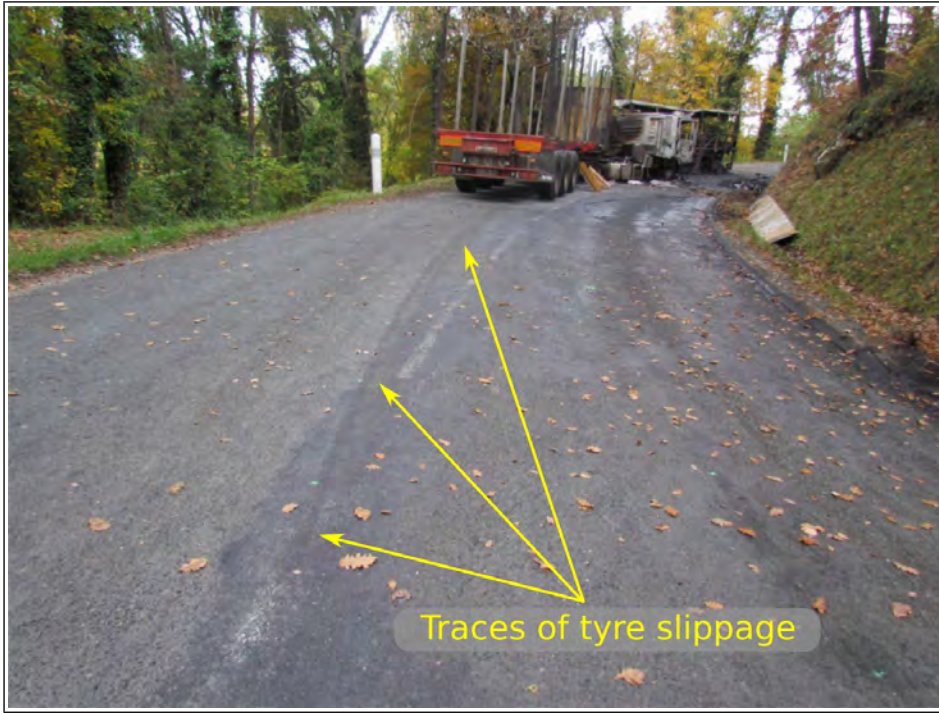
(police photo)

**Figure 7: View (from the direction in which the coach was travelling) of the position of the vehicles following the collision**

### 3.1.2 - Tyre tracks found on the road surface

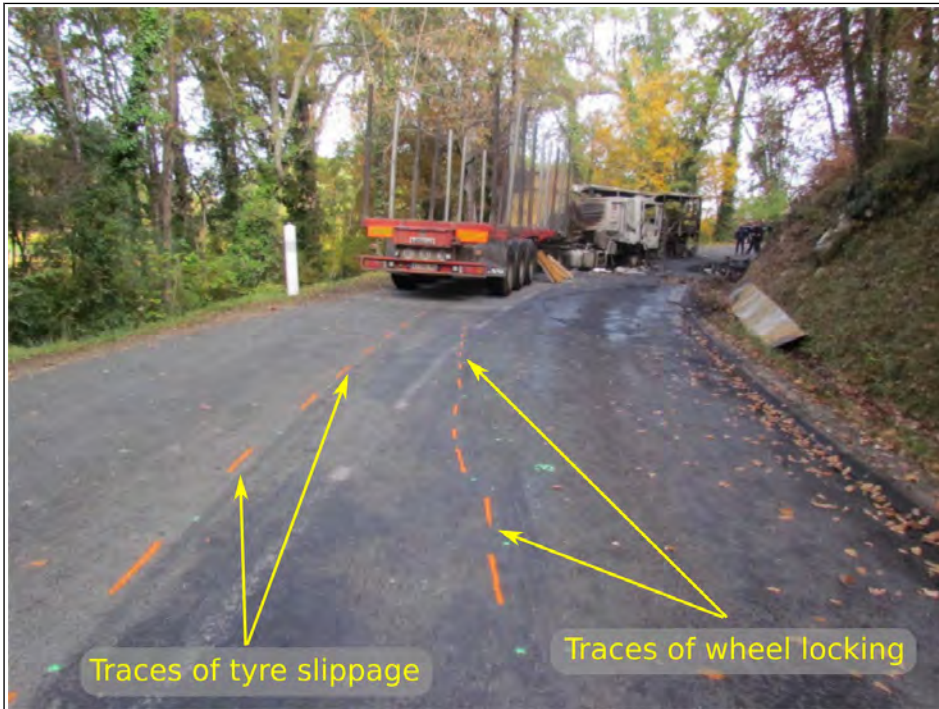
Leading up to the accident, in the direction in which the lorry was travelling, judicial investigators found two types of tyre tracks on the road surface: one caused by tyre slipping and two tracks caused by locked wheels.





(CL photo)

**Figure 8: View of the tracks caused by tyre slipping found on the road surface**



(CL photo)

**Figure 9: Close-up view of tracks found on the road surface, highlighted with red paint by judicial investigators**

### **3.1.3 - Infrastructural Damage**

The road surface and verges were badly damaged by the fire.

Several trees situated alongside the platform were also affected by the fire.

The roadside verges were stripped and cleaned, and a 170m stretch of the road was resurfaced.

## **3.2 - Witness Statement Summaries**

Summaries of witness statements have been compiled by technical investigators based on the oral and written statements they examined. The summaries retain only that information which has been deemed useful in understanding and analysing the events, and formulating recommendations. Disparities may exist between the various statements, or between these statements and the assessments or analyses which have been presented elsewhere.

### **3.2.1 - Witness statement from the coach driver**

The driver was hired to transport members of a seniors' club from the villages of Petit-Palais-et-Cornemps and Saint-Sauveur-de-Puynormand for a day of leisure activities in Arzacq-Arraziguët in the Pyrénées-Atlantiques, and to bring them back to Petit-Palais-et-Cornemps after the excursion.

He stated that he got up at 5.15am on the morning of the crash, then went to pick up the coach which was parked in a parking facility located near the town hall of Génissac en Gironde.

He then drove to the car park of the school in Petit-Palais-et-Cornemps to pick up his passengers. He arrived at 7am and drove off at around 7.15am, having taken 48 passengers on board.

He drove in the direction of Castillon-la-Bataille and through the town of Puisseguin. It was still dark and there was no rain, but the road surface was wet.

He stated that he entered the bend where the accident occurred while travelling at a speed of 40km/h. He stated that having entered the bend, while travelling in his own lane, he saw an articulated lorry which had "*jack-knifed*" coming towards him in the opposite direction. He was able to make out only the vehicle's marker lights. He stated that he applied the brakes and stopped his vehicle after a few metres, while also moving as far to the right as possible. The articulated lorry continued in its path and collided with the front left-hand side of the coach. At the moment of impact (which to the driver did not appear to be particularly violent), the coach was either stationary or had almost come to a halt.

The left-hand side of the coach's dashboard was displaced by the force of the collision, squeezing down on the driver's thigh.

A few seconds after the crash, a fire broke out between the lorry and the coach at the level of the windshield.

He felt the heat of the flames. He removed his seat belt, and after managing to get out of his seat, opened the coach's front door having "*depressurised*" it by pressing the safety button.

He exited the vehicle via this door while also helping two passengers to do the same.



He then made his way to the central door of the coach, which he opened by unlocking it from the outside.

He helped two or three people to exit the vehicle via this central door. The safety barrier positioned beside the stairs leading to this exit had buckled, partially blocking access to the stairwell. Attempting to rescue the other passengers, he tried unsuccessfully to push the safety barrier out of the way, but was unable to enter the coach due to the thick smoke and melted plastic falling from the ceiling. It was completely dark and there were no flames, but the heat was intense.

He returned to the front right-hand side door. He rescued a person who was lying under the dashboard, conscious but unable to move. He slid her down the stairs and laid her on the ground away from the bus.

The coach rapidly became engulfed in flames, making it impossible to access the vehicle's interior.

He then looked after the passengers who were able to evacuate the coach, and with the help of a passing motorist gathered them together on the roadside behind the vehicle.

He did not approach the vehicle again, as he was worried it might explode. A few minutes later he heard a series of small explosions, most likely the vehicle's windows, pneumatic systems and air pipes.

The emergency services then arrived, with the first teams arriving from Castillon.

### **3.2.2 - *Witness statements from coach passengers***

Statements were also taken from the seven passengers who were able to escape the vehicle. For ease of readability, these seven passengers are referred to as "P1" - "P7".

#### ***Witness statement from passenger "P1"***

This passenger stated that she was sitting in the window seat of the right-hand row, just behind the coach's central door. In front of her there was a safety barrier separating her seat from the stairs.

At the moment of impact, all the overhead lights in the coach went off, leaving all the passengers in complete darkness. Not having fastened her seat belt, she was thrown forward by the force of the impact. The barrier in front of her had broken, and so she found herself on the stairs.

Flames immediately began to appear at the front and on the right-hand side of the coach.

She saw a passenger from the row of seats to her left attempting to break the side window, before another passenger opened the central door on the right-hand side of the coach and helped her out.

Outside she saw the coach driver and a woman. She saw two other people exiting the coach, one of whom was a "*badly burned*" woman who was pulled out by the coach driver and a passing motorist.

The passenger who had attempted to break the window joined them shortly afterward.

### **Witness statement from passenger “P2”**

This passenger stated that he was seated towards the middle of the coach, by the window on the driver’s side. He had not fastened his seat belt.

He was reading a book when the accident occurred. Having felt the impact, he raised his head and immediately saw the fire breaking out on the lorry and the front of the coach. The flames were red in colour, glowing.

He immediately jumped up and grabbed the window hammer, which was located between his window and the one in front. He told the passenger seated to his right to follow him, shouted “*open the doors*”, smashed the window of the coach’s central door and exited through this opening, falling onto the roadside. The smoke had reached him before he left the coach, ahead of the flames. It was black, thick and acrid, giving off an odour of burning plastic.

He lost consciousness for a few moments; when he came to, the coach was completely ablaze. Outside the coach he saw the driver and two other passengers.

### **Witness statement from passenger “P3”**

This passenger stated they were seated in the aisle seat on the driver’s side of the vehicle’s 4<sup>th</sup> row (passenger “P4” also claimed to have been sitting in this seat). She had fastened her seat belt.

When the accident occurred, she felt the impact and heard a loud noise. The front of the coach caught fire immediately. White and black smoke began moving towards the back of the coach.

After unfastening her seat belt, she got up and followed the aisle to reach the vehicle’s central door on the right-hand side.

She fell down the stairs with another woman and found herself outside with her.

She then took shelter. The two women were met by a motorist who put them in his car until the emergency services arrived.

### **Witness statement from passenger “P4”**

This passenger stated that she was seated in the aisle seat of the vehicle’s 4<sup>th</sup> row, on the driver’s side.

She did not see the collision occur but was taken aback by the noise and force of the impact. She immediately saw flames rising at the front and then on the left-hand side of the coach where she was seated.

She got up and made her way to the central door on the vehicle’s right-hand side.

The door was open by the time she reached it. She was grasped by someone who pulled her outside the vehicle, and she found herself on the roadside.

This witness described how quickly the fire developed, with explosions, an intense heat and materials from the ceiling which were melting and dripping on to her.

### **Witness statement from passenger “P5”**

This passenger stated that he was seated on the right hand side of the vehicle beside passenger “P6”, in the 3<sup>rd</sup> row in front of the central door. He had fastened his seat belt.

After the impact, he saw the flames, unfastened his seat belt and passenger P6’s seat belt, and exited the vehicle via the open central door. He came back to the vehicle with another man, and with his help pulled two unconscious people out of the vehicle, who were lying in the stairs leading down to the door.

This passenger described an immediate conflagration and the presence of black smoke.

### **Witness statement from passenger “P6”**

This passenger stated that she was seated towards the back of the vehicle, 3 or 4 rows behind the central door on the vehicle’s right-hand side, in the aisle seat beside passenger “P5” (according to passenger P5’s statement, these seats were located 3 rows in front of the central door). She had fastened her seat belt.

At the moment of impact, her head was thrown against the seat in front of her, breaking her glasses. Passenger P5 unfastened her seat belt and brought her towards the central door. As she exited the vehicle, someone pulled her outside.

### **Witness statement from passenger “P7”**

This passenger stated that she was seated in the aisle seat of the first row on the right-hand side. She had fastened her seat belt.

The tour leader was seated in front of her on the small chair beside the door and the conductor.

When the coach entered the bend, she saw the headlights of an oncoming vehicle. She saw the lorry coming towards the left-hand side of the coach. The impact happened very quickly.

After the impact, she saw the coach driver “*fiercely kicking*” the door in order to open it.

She was pulled out of the coach by a person she later identified as the coach driver. She lay on her back on the ground while waiting for the emergency services.

### **3.2.3 - Witness statements from motorists present at the scene of the accident**

Witness statements were also taken from motorists who happened upon the scene of the accident.

These witnesses arrived on the scene after the collision, when the two vehicles had already caught fire. None of these motorists were in any way involved in the crash between the lorry and the coach.

The witnesses described a raging fire and several explosions, which quickly prevented them from approaching the vehicles to try and rescue the passengers still inside the coach.

### **3.3 - The coach**

#### **3.3.1 - Organisation of the excursion**

On October 23<sup>rd</sup> 2015, the seniors' clubs from the villages of Petit-Palais-et-Cornemps and Saint-Sauveur-de-Puynormand, both situated in the Gironde department (33), had organised an excursion to attend the "garbure" festival at Arzacq-Arraziguet in the Pyrénées-Atlantiques (66).

A tour leader and 47 people, mostly retirees from the villages of Petit-Palais-et-Cornemps and Saint-Sauveur-de-Puynormand, were participating in the excursion.

Transport for both legs of the journey between Petit-Palais and Arzacq-Arraziguet was provided by a local transport company.

The meeting point was the car park of the local school in Petit-Palais-et-Cornemps, with the departure time set for 7.15 am.

The coach set off on the road to Arzacq-Arraziguet (64) at around 7:15am.

#### **3.3.2 - The coach driver**

##### **3.3.2.1 - Experience and employment**

The coach driver was a 39-year-old man having held a category D licence to drive public transport vehicles since 1997. This licence was valid at the time the accident occurred.

The documents examined by the technical investigators did not reveal any failure to meet administrative requirements.

He had been employed by the transport company as a driver since April 2015.

##### **3.3.2.2 - Activity prior to the accident**

On Monday 19th and Tuesday 20th of October, the driver was off work. On Wednesday October 21st, he completed a journey towards Bordeaux.

On the day before the accident, Thursday October 22nd, he was also off work.

On Friday October 23rd, he got up at around 5.15am. He drove his personal vehicle to a car park located beside the Génissac town hall to pick up the coach, which was parked there.

At around 6.15am he left the car park driving the coach in order to make his way to Petit-Palais-et-Cornemps and pick up his passengers.

At around 7am, he arrived at the meeting point in Petit-Palais-et-Cornemps.

At around 7.15 am, having taken on board the 48 passengers, he set off on the road to Arzacq-Arraziguet (64).

The accident occurred at around 7.30, after roughly 15 minutes of journey time.

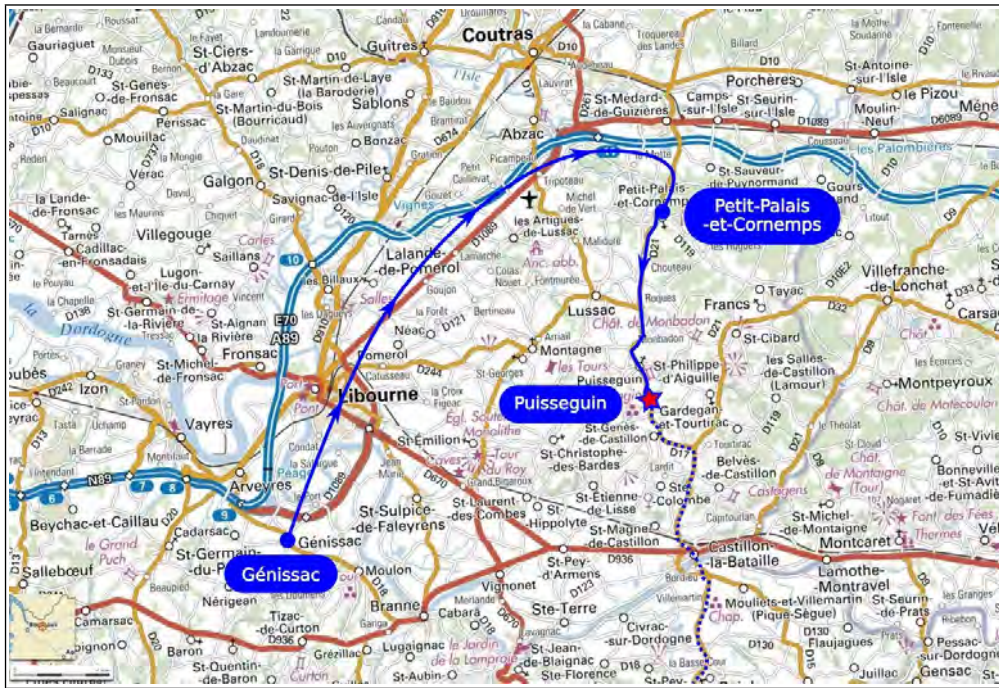


Figure 10: Journey taken by the coach on October 23rd

### 3.3.2.3 - Drug and alcohol testing

The driver was subjected to testing for drug and alcohol consumption, both of which were negative.

### 3.3.3 - Technical characteristics of the coach

The coach involved in the accident was a Mercedes Benz type R2 457H bearing the trade name Turismo RHD, belonging to a rental company which rented the vehicle to the transport company.

Its curb weight was 13.9 tonnes and its GVWR<sup>4</sup> was 19 tonnes.

The vehicle had 55 seats, all of which were fitted with seat belts.

Brought into operation in January 2011, the coach was in good overall condition at the time of the accident. It had passed a technical inspection on August 31st 2015, validating the vehicle's roadworthiness until February 29th 2016. The vehicle was compliant with active regulations in France.

Investigators were unable to determine the vehicle's mileage.

Its motor was positioned lengthways towards the rear of the vehicle. The coach ran on diesel fuel.

The coach was equipped with both heating and air conditioning systems.

4 Gross Vehicle Weight Rating



(police photo)

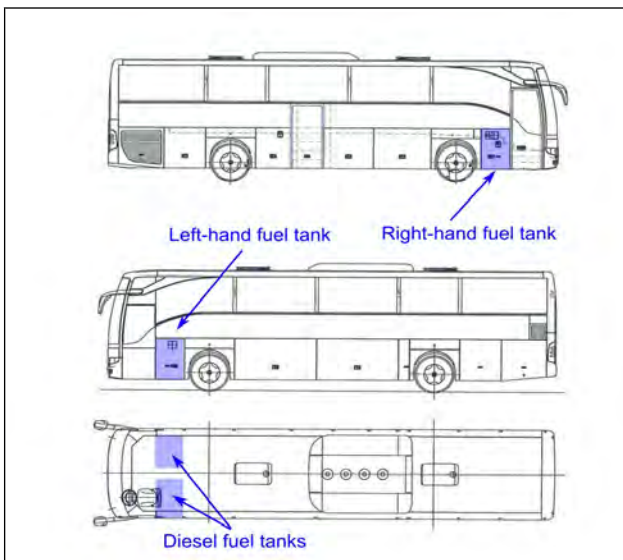
**Figure 11: View of the coach before the accident**

The following paragraphs describe the equipment, materials and systems in place on board the coach which may have played a role in the development of the fire, as well as the vehicle's safety features.

### 3.3.3.1 - Description and position of fuel tanks

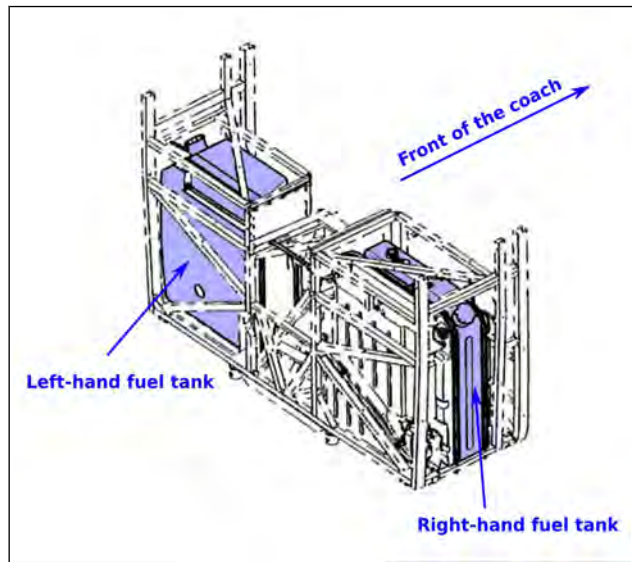
The coach was fitted with two polyethylene fuel tanks positioned in front of the front axle, roughly 1.5m behind the front end of the superstructure:

- The right fuel tank had a capacity of 235 litres;
- the left fuel tank had a capacity of 264 litres.



(EV document annotated by the BEA-TT)

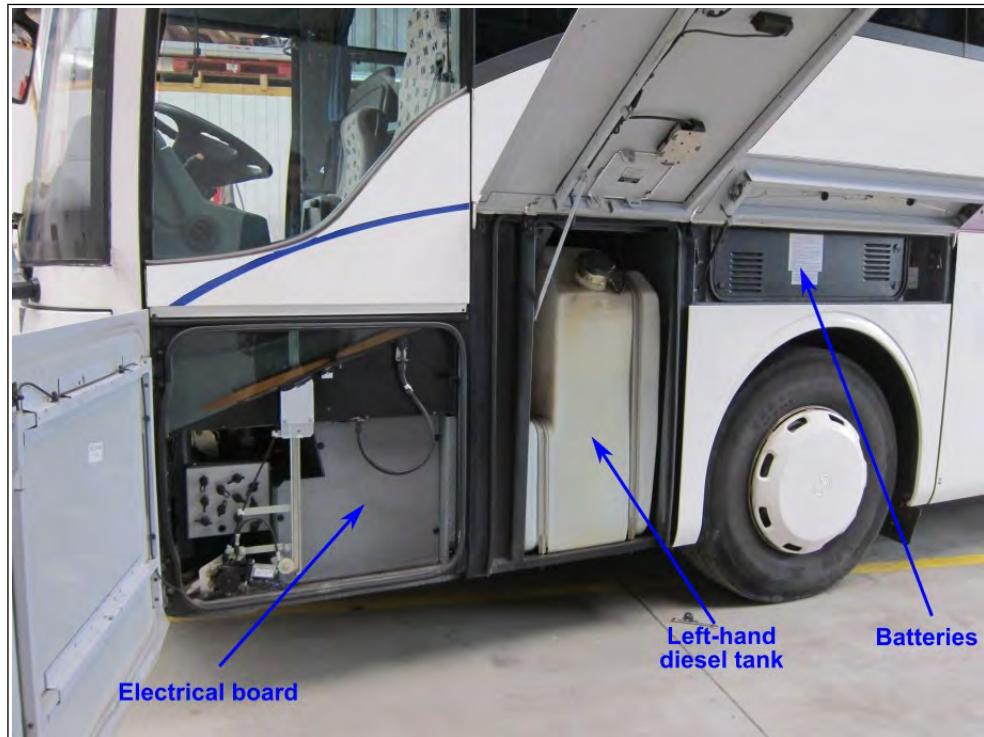
**Figure 12: Position of coach's fuel tanks**



(EV document annotated by the BEA-TT)

**Figure 13: Diagram of coach's fuel tanks**





(BEA-TT photo)

**Figure 14: View of the left-hand side fuel tank on a coach similar to the one involved in the accident**

It is noteworthy that the left fuel tank is situated between the coach's battery compartment and the electrical board.

The coach ran on diesel fuel, whose primary characteristics are:

- Physical state at 20°C: liquid;
- Flash point<sup>5</sup>: > 55 °C;
- Autoignition temperature<sup>6</sup>: > 250 °C.

This fluid is stable at the recommended temperatures for handling and storage, and does not present any risk of dangerous reactions under normal conditions of use. However, it should not be exposed to temperatures exceeding its flash point, nor to any spark, ignition source, naked flames or static electricity.

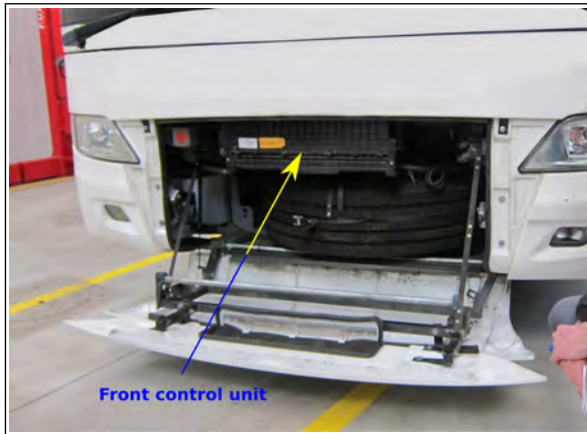
Two extracts from the material data safety sheet for "Total Diesel Premier" diesel fuel indicating its physical and chemical properties regarding stability and reactivity are included in Appendix 9 of this report.

5 The flash point is the lowest temperature at which a combustible material will emit vapours which, together with the surrounding air, form a gaseous mix that will ignite upon contact with an ignition source; however, this temperature is too low for the material itself to spontaneously combust.

6 The fire point is the lowest temperature at which a fuel emits enough vapours to form, along with the surrounding air, a gaseous mix that will catch fire and continue to burn when in contact with an open flame. When the combustion mechanism is activated without any open flame, this is referred to as the autoignition temperature.

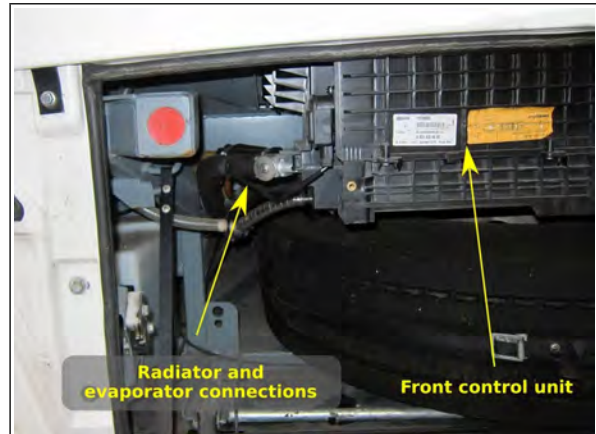
### 3.3.3.2 - Description of heating and air conditioning systems

The vehicle's heating and air conditioning systems run on two separate circuits, each using fluids with differing characteristics. However, our analysis of these systems (cf Appendix 6) indicates that they share the use of certain technical components, at which points their systems converge. This is the case in particular for the frontal control unit.



(BEA-TT photo)

**Figure 15: View of the frontal heating and air conditioning control unit on a similar coach**



(BEA-TT photo)

**Figure 16: View of the connectors linking the frontal control unit to the heating and air conditioning systems on a similar coach**

### 3.3.3.3 - Description of the frontal heating and air conditioning control unit

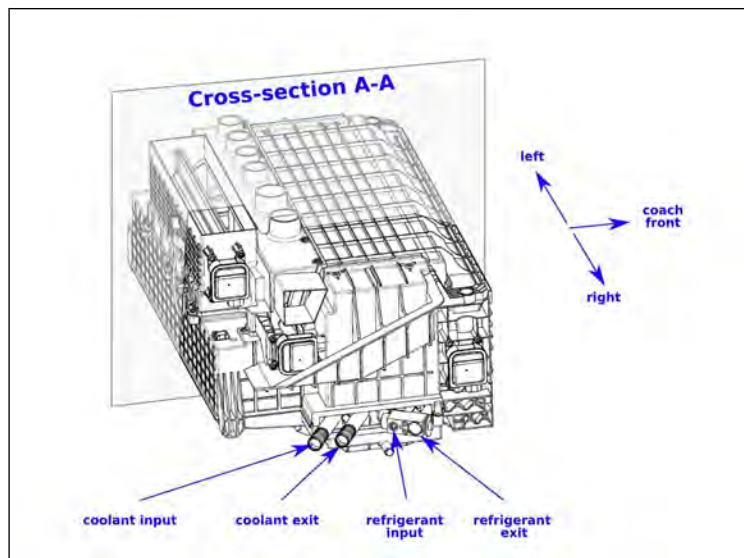
The exchange unit installed at the front of the coach has a dual purpose: providing heating for the front of the coach and the driver's seat, and providing air conditioning.

Inside this control unit there are two heat exchangers:

- a radiator connected to the coach's heating system, circulating Glystantin G38-type heat transfer fluid
- an evaporator connected to the coach's air conditioning system, circulating R134a coolant.

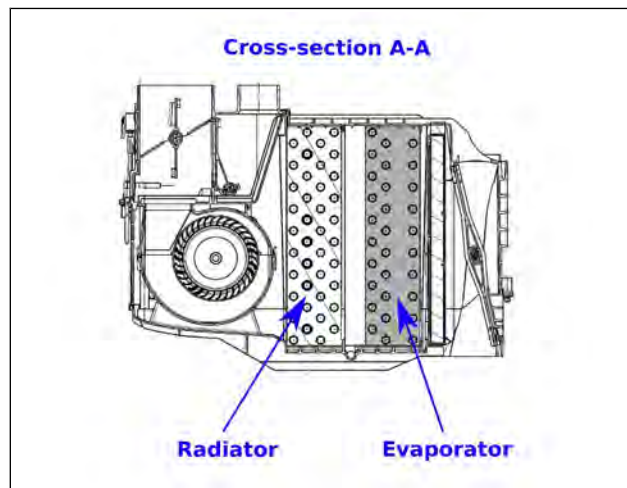
Figures 17 and 18 provide a schematic view of the position of the heating radiator and the air conditioning evaporator in the control unit, and their connection to the heating and air conditioning circuits.





(EV document annotated by the BEA-TT)

**Figure 17: Diagram of frontal heating and air conditioning control unit**



(EV document annotated by the BEA-TT)

**Figure 18: Cross-section of the frontal heating and air conditioning control unit**

**The coolant fluid** used in the coach's air conditioning system is R134a.

Stable at ambient temperatures and under normal conditions of use, its primary characteristics are as follows:

- Physical state at 20 °C: gaseous;
- Melting point<sup>7</sup>: -101 °C;
- Boiling point<sup>8</sup>: -26.4 °C ;
- Flash point<sup>9</sup>: > 55 °C;
- Autoignition temperature<sup>10</sup>: 743 °C.

<sup>7</sup> The melting point is the temperature at which, at a given level of pressure, a material will melt, i.e.: pass from a solid state to a liquid state.

<sup>8</sup> The boiling point is the temperature at which, at a given level of pressure, a substance will pass quickly from a liquid to a gaseous state.

<sup>9</sup> cf. note 5

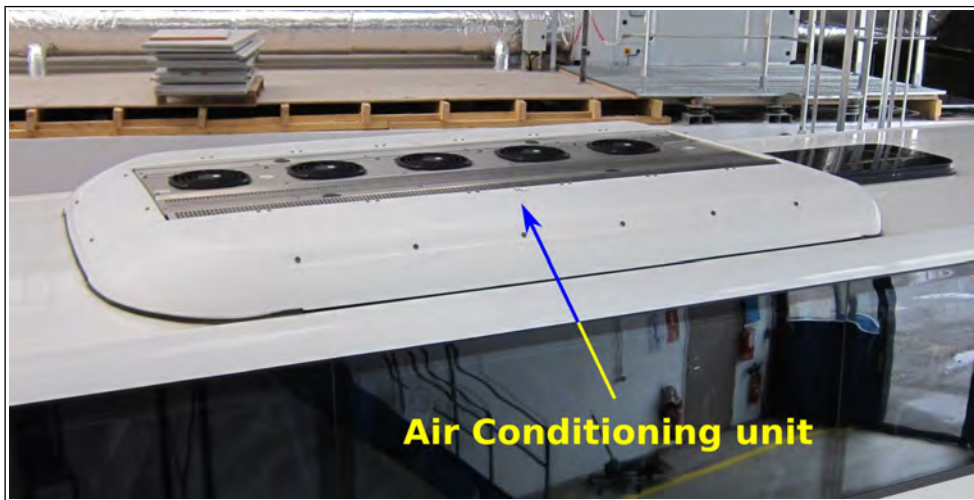
<sup>10</sup> cf. note 6

**The heat transfer fluid** used in the coach's heating system is Glystantin G48. This fluid is stable under normal conditions of use, and its primary characteristics are as follows:

- Physical state: liquid;
- Boiling point  $\geq 165$  °C;
- Flash point:  $> 126.5$  °C;
- Autoignition temperature:  $> 440$  °C.

An extract from the material data safety sheet for these fluids, indicating their physical and chemical properties and primary characteristics regarding reactivity and stability, are included in Appendices 7 and 8 of this report.

Another component in which the heating and cooling circuits converge is the unit installed on the roof of the vehicle, which includes (among other elements) fans.



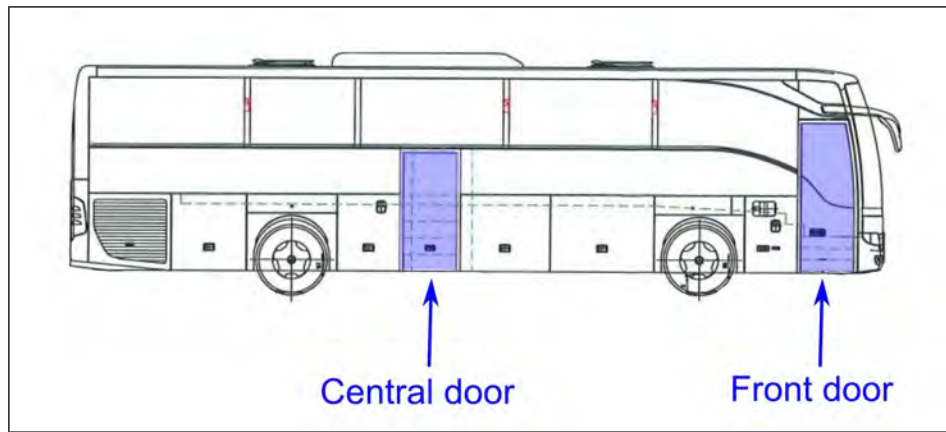
(BEA-TT photo)

**Figure 19: View of the air treatment unit on the roof of a similar coach**

#### **3.3.3.4 - Description of evacuation measures: doors, lighting and emergency exits**

##### **Doors**

The coach was equipped with two doors allowing passengers to board and alight the vehicle. Both were situated on the vehicle's right-hand side, one at the front and one in the middle.



(EV document annotated by the BEA-TT)

**Figure 20: Position of coach door**

Boarding and alighting the vehicle via either door was achieved via a flight of steps, allowing only one person to pass at a time.

The stairs at the front of the bus included a small landing near the driver's seat.

The central stairs were particularly steep and narrow, and were bordered by the coach's toilets on one side and a safety barrier on the other.



(BEA-TT photo)

**Figure 21: View of the central door from outside the coach**



(BEA-TT photo)

**Figure 22: View of the front entrance from outside the coach**



(BEA-TT photo)

**Figure 23: View of the central door from the inside of the coach**



(BEA-TT photo)

**Figure 24: Alternative view of the central door from inside the coach**

### **Opening and closing the doors**

The two doors were opened and closed via the use of a pneumatic mechanism operated from the driver's seat, or from the doors themselves.

The doors could also be opened by using the security handles located beside each door on both the inside and outside of the coach. Pulling the emergency handle causes the pressure to drop in the door's pneumatic circuit, allowing the door to be opened manually.

In the event that the pneumatic system controlling the doors is compromised (e.g. during a collision) the pressure will automatically drop after 8 seconds and the doors can then be opened manually.

### **Lighting and emergency exits**

The coach was not equipped with any emergency lighting measures.

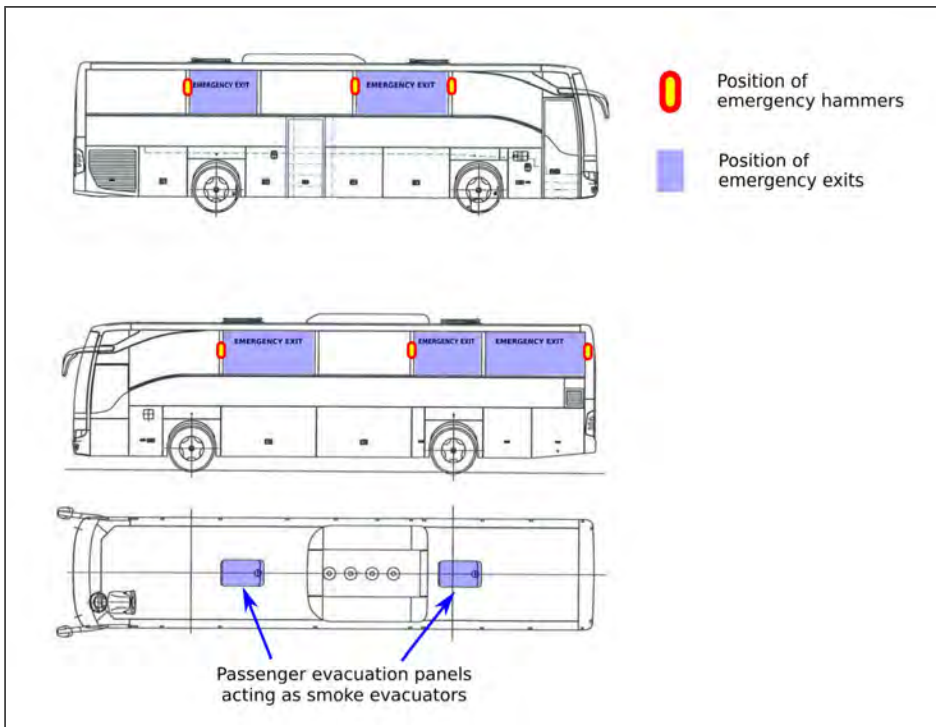
The emergency exits were located on the roof and sides of the vehicle.

On the roof, the vehicle was equipped with two passenger evacuation panels, which also acted as smoke evacuators. The use of these emergency exits is recommended when the coach is lying on its right-hand side, rendering its doors unusable. The emergency roof exits are opened via ejection or by breaking with an emergency hammer (located near the exit).

The sides of the coach are equipped with five windows acting as emergency exits; two on the right and two on the left. The words "Issue de secours" ("Emergency Exit") were displayed on these windows, each of which also had an emergency hammer located just beside it. In order to use these emergency exits, they must first be broken using an emergency hammer.

The diagram and photographs in figures 25 - 27 below show the position of emergency exits and emergency hammers for a coach similar to the one involved in the accident.





(EV document annotated by the BEA-TT)

**Figure 25: Position of emergency exits and emergency hammers on the coach**



(BEA-TT photo)

**Figure 26: View of an emergency hammer for a side window on a coach similar to the one involved in the accident**



(BEA-TT photo)

**Figure 27: View of an emergency exit on the roof of a coach similar to the one involved in the accident**

In light of their examination, BEA-TT investigators made the following observations:

- the central exit was accessed via a steep and narrow staircase, whose steps were much higher than those found at the front door, making the stairs more difficult to climb or descend;
- in the absence of emergency lighting and smoke extractors, emergency exits and materials are not visible at night or when the vehicle cabin is filled with smoke.

### **3.3.3.5 - Description of materials used in the coach's interior and their fire resistant properties**

The ceiling covers, baggage rails and door/window frames were mostly made using ABS<sup>11</sup>, polypropylene and polyurethane.

The sides of the coach were made up of insulating wood fiber panels.

The seat covers, curtains and interior decor materials were made of fabrics containing polyester, wool and viscose.

The seat stuffing was made from polyurethane.

The flooring was made from wood with a PVC floor covering, while the carpet for the aisle was made mostly from polyamide and polyester fibres.

These materials were in compliance with ECE/ON regulation n°188 regarding uniform technical requirements concerning the burning behaviour of materials used in the construction of certain categories of motor vehicles, as well as European Directive 95/28 regarding the burning behaviour of materials used in the interior construction of certain categories of motor vehicle.

The melting point varies for each material used (between 220°C and 250°C for ABS, and around 190°C for polyurethane). As a general rule, the materials used, although compliant with existing regulations, were flammable above a certain temperature.

The gases released by combustion of these materials are known on a theoretical basis only,<sup>12</sup> and are not subject to testing under legislation.

### **3.3.4 - Expert assessment of the coach**

#### **3.3.4.1 - Condition of the vehicle prior to the accident**

The coach had been issued with a certificate of compliance. It was in good condition and no modifications or anomalies were observed which could have influenced the vehicle's range of motion before the collision, its response to the impact or its response to the outbreak of a fire.

#### **3.3.4.2 - Damage to the coach**

The coach was completely destroyed by the fire that broke out following the collision. All flammable materials were consumed, leaving only a small amount of unusable residue behind.

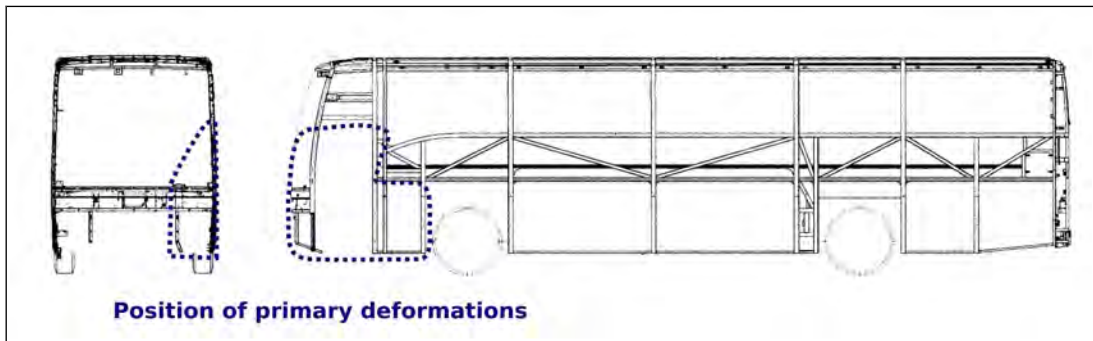
The vehicle's metallic structure and lining panels were deformed by the heat of the fire.

---

<sup>11</sup> ABS or acrylonitrile butadiene styrene is a thermoplastic polymer often used in automobile construction.

<sup>12</sup> The gases released by the combustion of these materials consisted mainly of CO (carbon monoxide), CO<sub>2</sub> (carbon dioxide), HCN (hydrogen cyanide), NH<sub>3</sub> (ammonia), and HCL (hydrogen chloride), all of which are highly toxic.

The vehicle suffered a frontal collision with the lorry on its left-hand side, causing its solid structures to be pushed back. The deformations to the vehicle's structure were mostly concentrated in the areas indicated in figures 28 - 31 below.



(EV document annotated by the BEA-TT)

**Figure 28: Position of areas of structural damage to the coach**



(police photo.)

**Figure 29: Wider view of coach**

The vertical structure on the coach's front left-hand side had been crushed inwards by around 80cm.

The coach driver's seat was pushed backwards to a significant degree from the front left-hand side.

The electrical board situated on the front left-hand side of the coach, as well as the structure protecting the left fuel tank were heavily deformed by the impact with the tractor unit. The space between the exterior stanchions for the fuel tank compartment was reduced by around 65%.

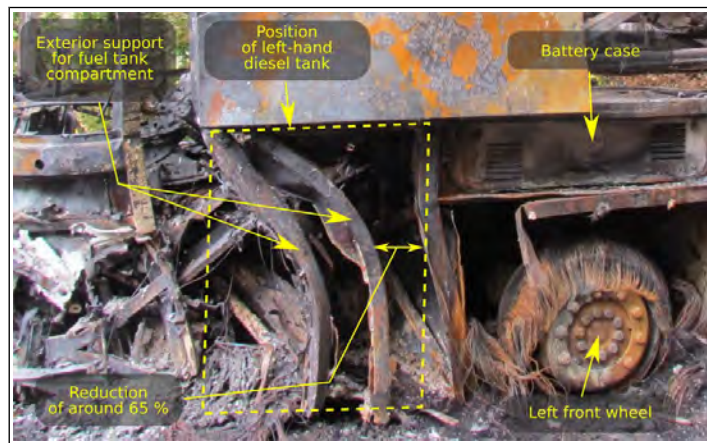
The BEA-TT investigators have surmised that the left-hand side fuel tank located within the impact zone was most likely also crushed, which may have led to its rupture during the collision.





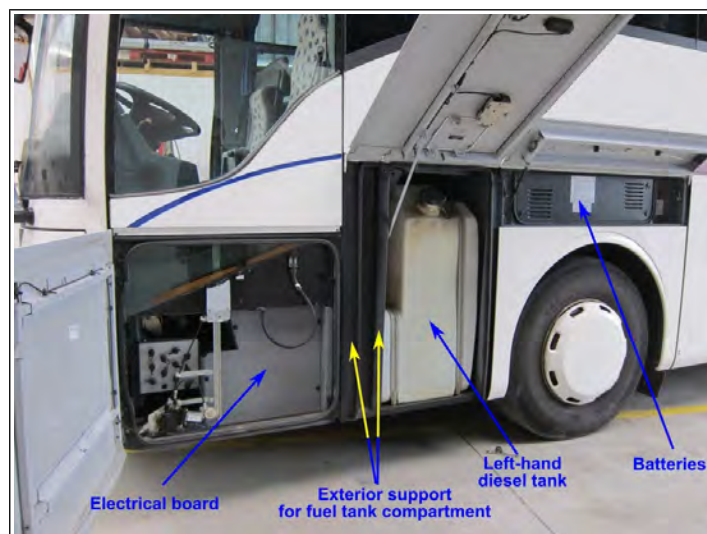
(police photo.)

**Figure 30: View of the front left-hand side of the coach involved in the accident**



(police photo.)

**Figure 31: Close-up view of the front left-hand side of the coach involved in the accident**



(police photo.)

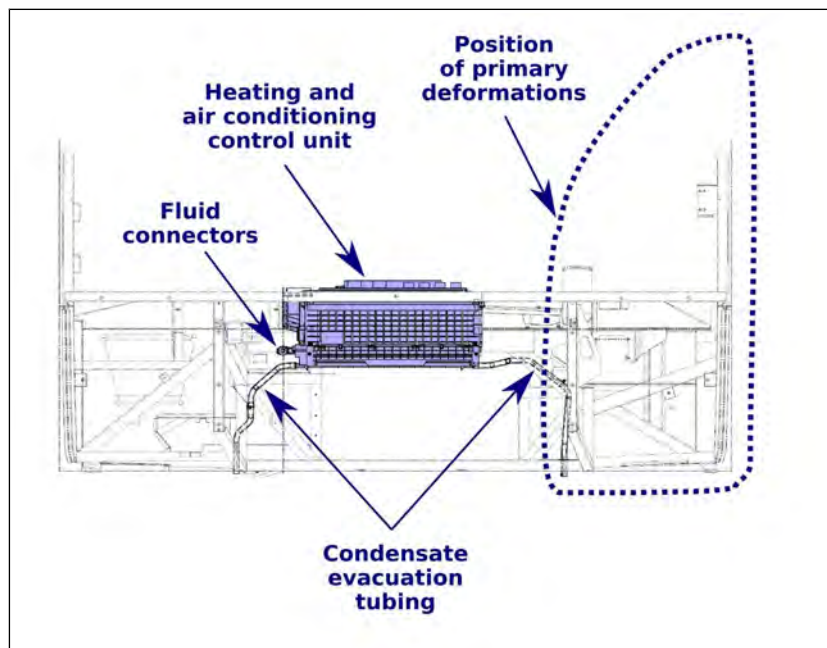
**Figure 32: Close-up view of the front left-hand side of a coach similar to the one involved in the accident**



The battery compartment situated above the left front wheel does not show any major deformation. The battery elements are correctly assembled and the terminals are still in place, allowing us to exclude the possibility of an internal explosion.

The central and right-hand side portions of the coach's front do not show any signs of direct impact with the lorry.

The coach's frontal heating and air conditioning control unit was partially destroyed in the fire. The radiator and evaporator installed in this control unit were not destroyed by the fire, and were lying on the ground. They showed no visible signs of being crushed.

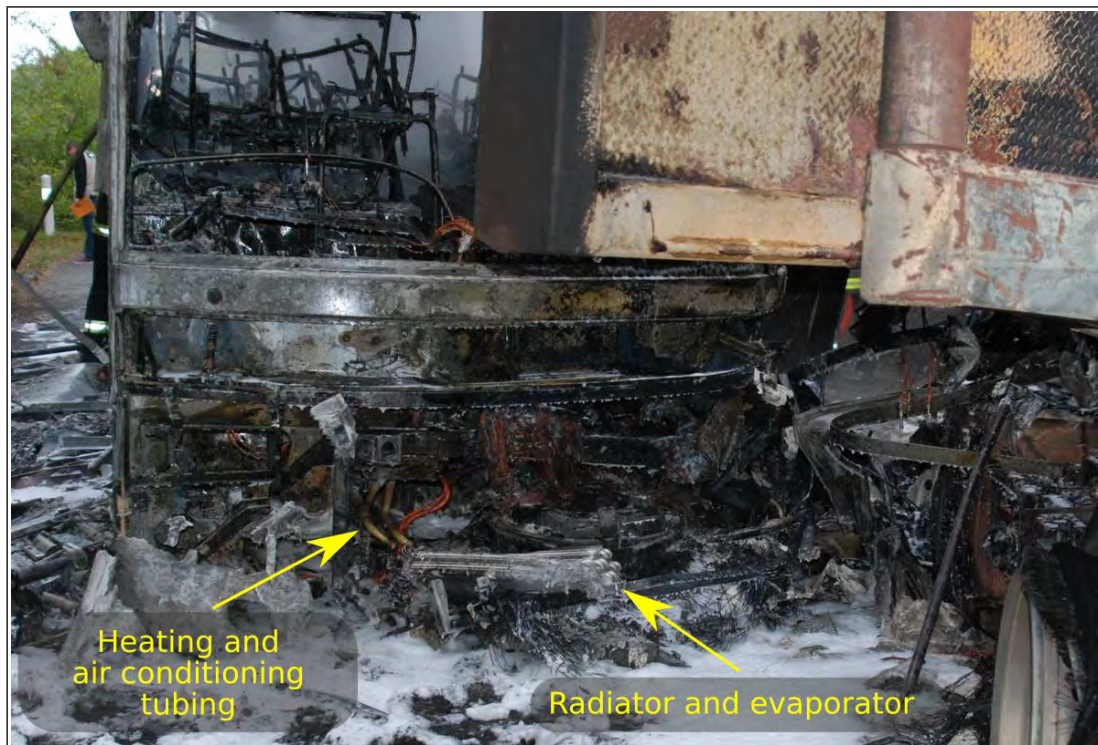


*(EV document annotated by the BEA-TT)*

**Figure 33: Position of the heating and air conditioning control unit and areas of structural damage on the front of the coach**

In light of these observations, the BEA-TT investigators have ruled out the hypothesis that a direct impact with the frontal heating and air conditioning control unit was what led to the sudden rupture of the heating and air conditioning circuits. Their role in causing the two vehicles to be consumed by fire can therefore be dismissed.

Figure 34 below provides a view of the front of the coach, the radiator and the evaporator as well as the tubing to which they were attached as they were found by the judicial investigators once the blaze had been quelled by the firefighters.



(police photo.)

**Figure 34: View of the front of the coach involved in the accident**

### **3.3.4.3 - Analysis of data recorded by the coach's tachograph**

The tachograph installed on the coach was completely destroyed by the fire. Investigators were therefore unable to carry out any examination of the data recorded by this device.

## **3.4 - The articulated lorry**

### **3.4.1 - The driver of the articulated lorry**

#### **3.4.1.1 - Experience and employment**

The driver of the articulated lorry was a 31-year-old male who had worked as a HGV driver for 12 years with a family-owned haulage company.

He held a driving licence authorising him to drive heavy goods vehicles.

He had been hauling timber for 4 years.

The driver carried out wood haulage operations as a "company driver" on behalf of another transport company; i.e. one company rents the driver's tractor unit and labour to a second company, who provides the trailer unit and a transport contract of variable duration.

The documents provided to the investigators revealed no anomalies in the driver's administrative obligations.



### 3.4.1.2 - Activity prior to the accident

The driver of the articulated lorry was off work on Saturday October 17th and Sunday October 18th, spending the weekend at his home in Orne (61).

He went back to work on Monday October 19th, bringing his 3-year-old son with him.

He made his way to the depot of a company based in Mayenne (53) to pick up his articulated lorry (which had been left there over the weekend), and drove off to begin a week's work along with his son.

After various wood haulage operations completed at the beginning of the week in Normandy, Pays de Loire, Poitou-Charentes and Aquitaine, on the morning of Thursday October 22nd he made his way to Champrond-en-Gatine in Eure-et-Loire (28) to take on a consignment of logs, to be delivered to Saint-Michel-de-Montaigne in Dordogne (24) on the following morning. Upon delivery, he was to travel to Loches en Indre-et-Loire (37) to take on a final load and return to the company depot.

On the evening of Thursday October 22nd, he stopped for the night in the car park of a restaurant in Coutras, Gironde (33). He slept in the cabin of his tractor unit with his son.

He left Coutras on Friday October 23rd 2015 at around 5.30am and made his way to the premises of a company based in Saint-Michel-de-Montaigne, Dordogne (24) to deliver his cargo of wood.

He arrived in Saint-Michel-de-Montaigne at around 6am and left at around 7am, having unloaded his cargo.

The accident occurred at around 7.30am, after roughly 20-30 minutes of journey time.

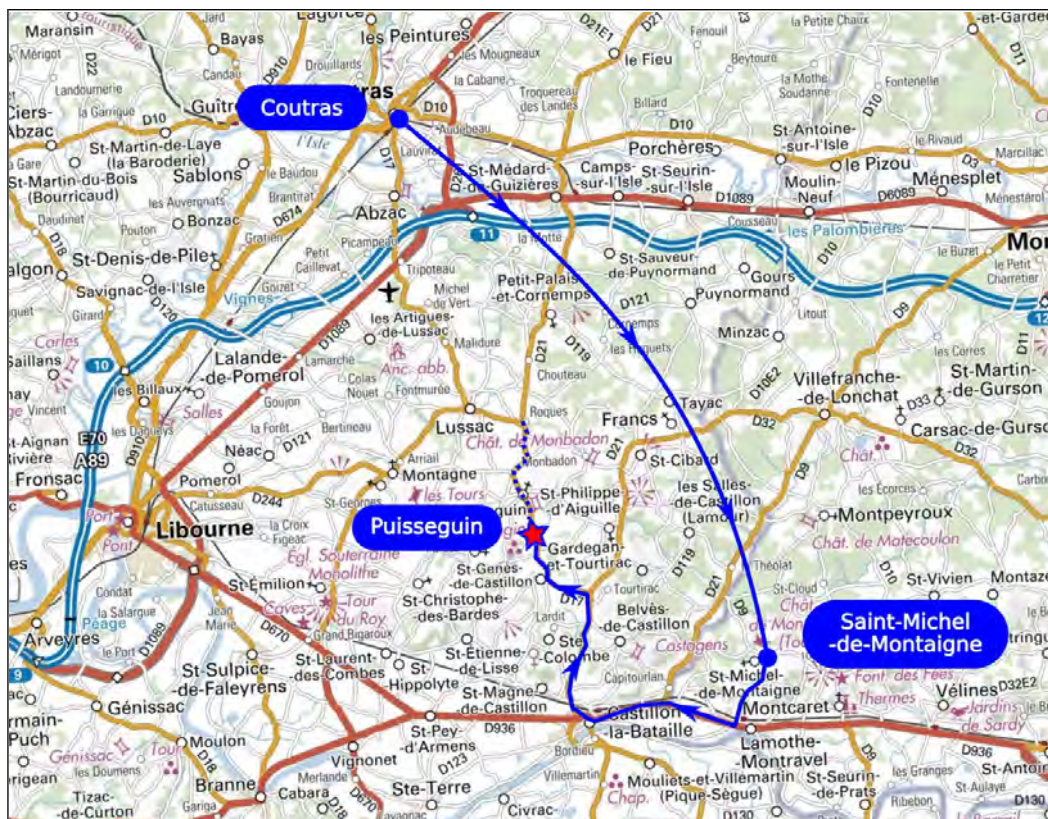


Figure 35: Journey taken by the articulated lorry on October 23rd

### 3.4.1.3 - Drug and alcohol testing

Tests for drug and alcohol consumption (carried out *post mortem*) came back negative.

### 3.4.2 - Technical characteristics of the tractor unit

The articulated lorry consisted of an IVECO tractor unit and a BILLAUD semitrailer.

The tractor unit was an IVECO model AS40 S56 TZP HM (category N3<sup>13</sup>), belonging to a rental society located in Sarthe (72), which rented the unit to the transport company.

It was equipped with a diesel-fuelled engine.

The vehicle was registered in September 2014.

It had undergone a technical inspection on August 24th 2015, validating the vehicle's roadworthiness until August 24th 2016.

Investigators were unable to determine the vehicle's mileage.

The vehicle's primary technical characteristics were as follows:

- GVWR of 26 tonnes;
- GCVWR of 60 tonnes.



(police photo.)

**Figure 36: View of the IVECO tractor unit involved in the accident**

The tractor unit was equipped with an Electronically Controlled Brake System (EBS), which included the following four functions:

- ABS (Anti-lock Braking System): a system preventing the wheels from locking when braking;
- BAS (Brake Assistant System): a system to amplify braking power in emergencies;

---

13 The vehicle was designed and built to transport freight with a maximum weight of over 12 tonnes.

- EBL (Electronic Brakeforce Limitation): a system that optimises braking power based on load weight;
- ASR (Anti-Slip Regulation): system preventing the drive wheels from slipping during acceleration;
- However, the tractor unit was not equipped with ESB or AEBS systems:
- ESB (Electronic Stability Program): system designed to control the vehicle's lateral movement, particularly in order to improve stability in coupled vehicles during understeer and oversteer;
- AEBS (Advanced Emergency Braking System): a system which automatically activates the vehicle's braking systems in order to avoid a collision or reduce the speed of impact.

The following paragraphs describe the equipment, materials and systems installed on the tractor unit which may have played a role in causing or spreading the fire.

#### **3.4.2.1 - Position of the fuel tank and main mechanical components of the tractor unit**

The tractor unit was fitted by its manufacturer (IVECO) with a 540-litre aluminium fuel tank, mounted lengthwise on the right-hand side of the tractor unit. Its dimensions were as follows: 1.44m in length, 0.64m in height and 0.69m in width.

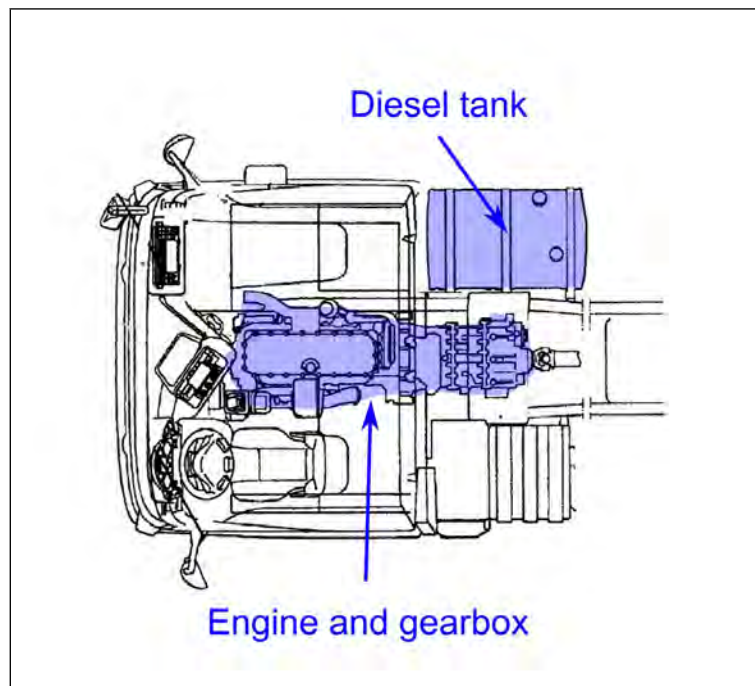


*(police photo.)*

**Figure 37: View of a similar primary fuel tank to the one fitted on the IVECO tractor unit involved in the accident**

The main mechanical components on the tractor unit containing fluids that might have escaped and caught fire during the collision are mostly located in the centre of the vehicle underneath the cabin.

Figure n°38 shows their position on the tractor unit.



(Document IV annotated by BEA-TT)

**Figure 38: Position of the motor, gearbox and fuel tank on the tractor unit (seen from above)**

### 3.4.2.2 - Description of the exhaust system and exhaust gas treatment system on the tractor unit

In order to comply with European Directive 64/2012A/UE (Euro Standard 6<sup>14</sup>), the tractor unit was equipped with anti-pollution devices to treat exhaust gases, combining two successive devices:

- a catalytic converter / particle filter for the treatment of non-combusted hydrocarbons, carbon monoxide and particles,
- a device to treat nitrogen oxides, notably including a catalytic reduction device (SCR).

Schematically, the device operates as follows:

Initially, the exhaust gases pass through an oxidising catalytic converter, in which hydrocarbons and carbon monoxide are converted into water and carbon dioxide. The exhaust gases then pass through a particle filter, which retains carbonated particles in the form of dust.

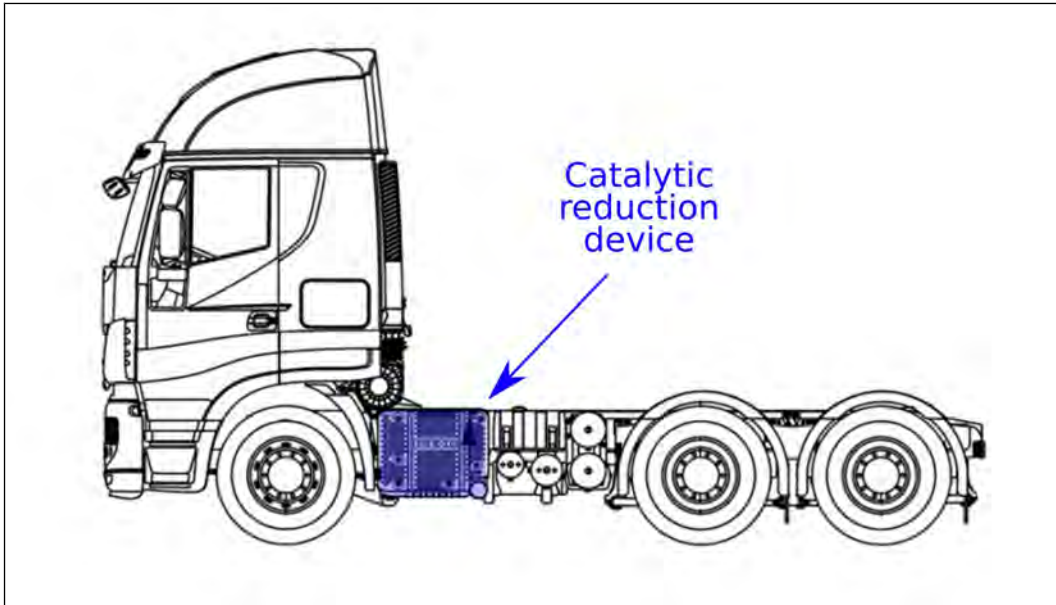
In the second phase, a water/urea solution (AdBlue®) is mixed with the exhaust gases ahead of the SCR catalyser. This solution works by transforming nitrogen oxides found in the exhaust gases into nitrogen and water vapour.

Figures 39 - 41 below show the position of the catalytic reduction device on the tractor unit.

---

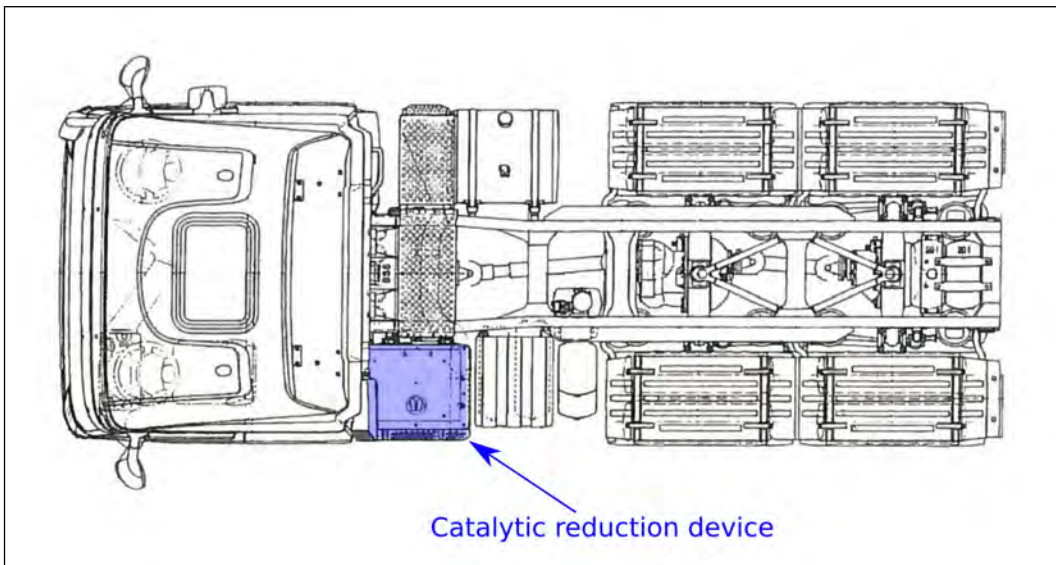
<sup>14</sup> European emissions standards, known as "Euro standards", are the European Union regulations which set the maximum limits for polluting emissions released by motor vehicles.





(Document IV annotated by BEA-TT)

**Figure 39: Side view of the installation of the catalytic reduction device on the tractor unit**



(Document IV annotated by BEA-TT)

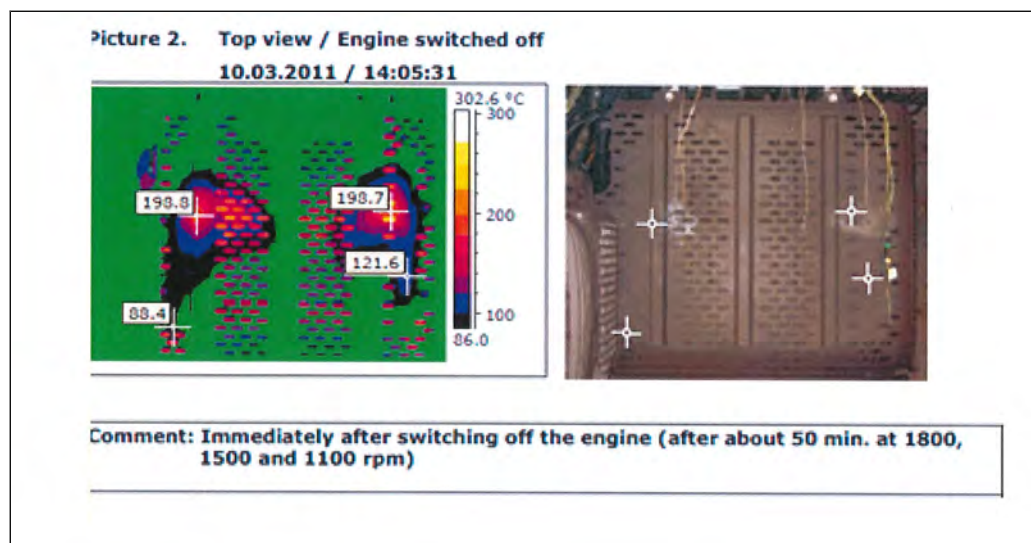
**Figure 40: Top-down view of the position of the catalytic reduction device on the tractor unit**



(police photo.)

**Figure 41: View of the catalytic reduction device on the tractor unit**

These reactions occur at high temperatures, with exhaust gases capable of reaching temperatures of 500-600 °C as they exit the motor. Figure 42 below, submitted by the tractor unit manufacturer (IVECO), shows the temperatures reached by the metallic sheet protecting the catalytic reduction device during measurements taken immediately after the motor had been shut off after 50 minutes of activity - temperatures rising to as high as 200°C. The components of the catalytic reduction device, protected by this metal covering, reach even higher temperatures.



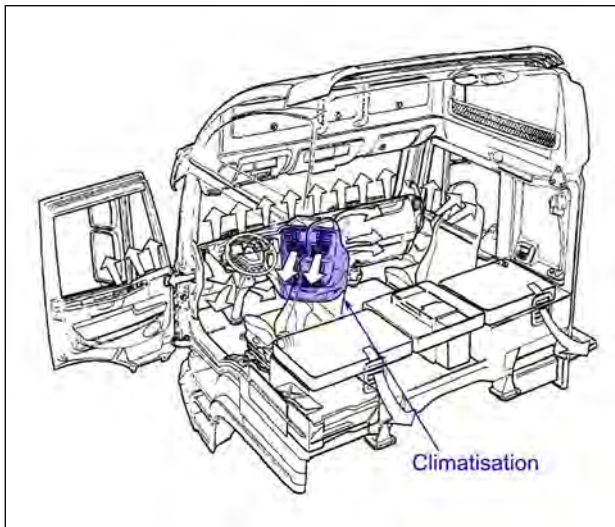
(document IV)

**Figure 42: Temperatures measured on the outer surface of the catalytic reduction device after shutting off the vehicle's motor**



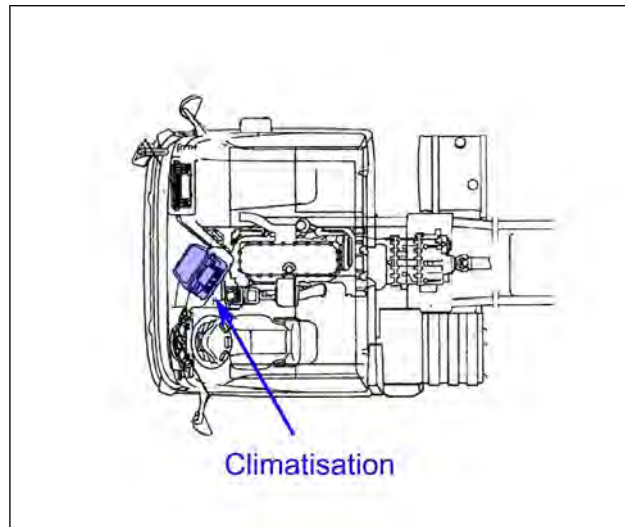
### 3.4.2.3 - Description of the tractor unit's air conditioning system

The cabin of the tractor unit was equipped with an air conditioning system. The coolant used in this air conditioning system is R134a, which is non-flammable (cf. Appendix 7). Figures n° 43 and 44 below show the position of this system on the tractor unit.



(Document IV annotated by BEA-TT)

**Figure 43: Position of the air conditioning control unit in the tractor unit's cabin (perspective view)**



(Document IV annotated by BEA-TT)

**Figure 44: Layout of the highway tractor's air conditioning unit in the cab (top-down view)**

### 3.4.3 - Modifications made to the tractor unit following its factory release

The expert assessment of the vehicle showed that following its factory release, the following modifications had been made to the tractor unit:

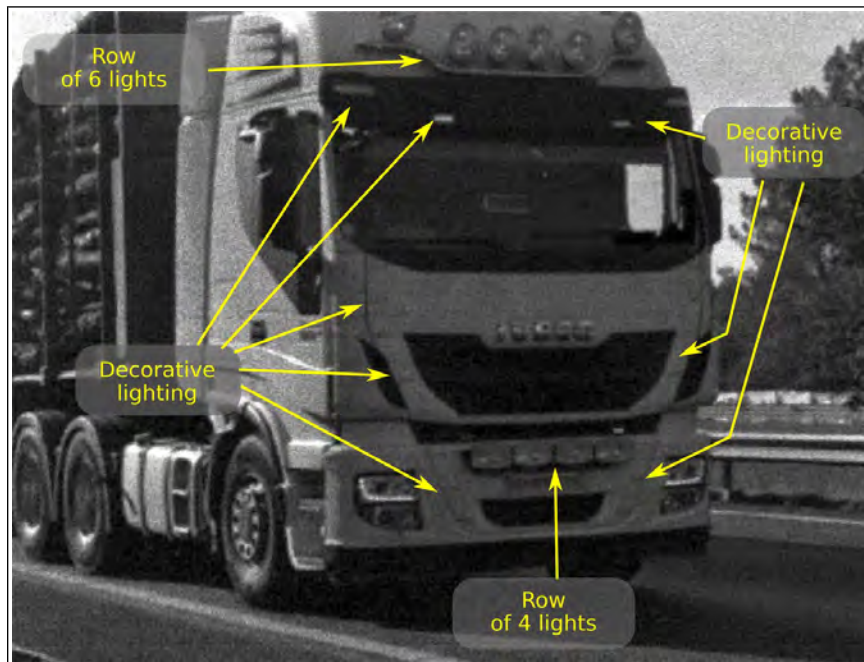
- addition of headlights and other lights;
- addition of two tanks behind the cab: one fuel tank and a tank containing an aqueous urea solution (commercial name AdBlue®);
- fifth-wheel coupling moved further towards the rear of the vehicle.

#### 3.4.3.1 - Addition of headlights and other lights

The tractor unit was equipped with various vehicle lights and decorative lights in addition to its approved factory configuration. In particular, the investigation showed that the following had been installed:

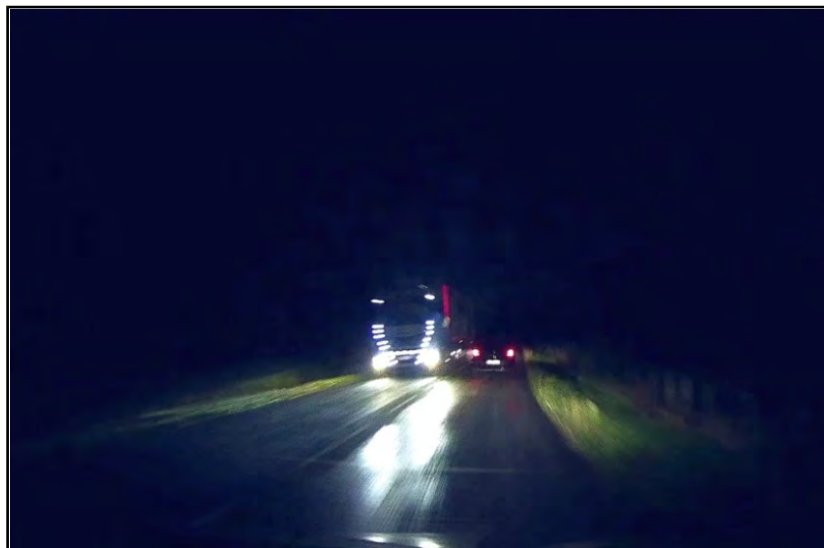
- a row of six lights above the cabin;
- four decorative lights around the sun-visor in the upper cabin,
- four lights below the radiator grill;
- a dozen decorative lights on the bumper and radiator grill.

Figures 45 and 46 below show the lights installed on the tractor unit and the expected light output when they were switched on.



(police photo.)

**Figure 45: View of the headlights and decorative lights on the tractor unit**



(police photo.)

**Figure 46: View of the tractor unit using dipped headlights with the decorative lights switched on.**

Current regulations limit the number of dipped beams to two (Article R. 313-3 of the French Highway Code) and the number of full beams to four (article R. 313-2 of the French Highway Code). The investigations carried out did not allow us to ascertain whether or not the tractor unit complied with these rules.

Elsewhere, current regulations prohibit luminous decorations on vehicle exteriors (Article R. 313-1 of the French Highway Code).

The lights installed on the tractor unit were therefore not compliant with existing regulations, but nor did they have any influence on the cause or consequences of the accident.

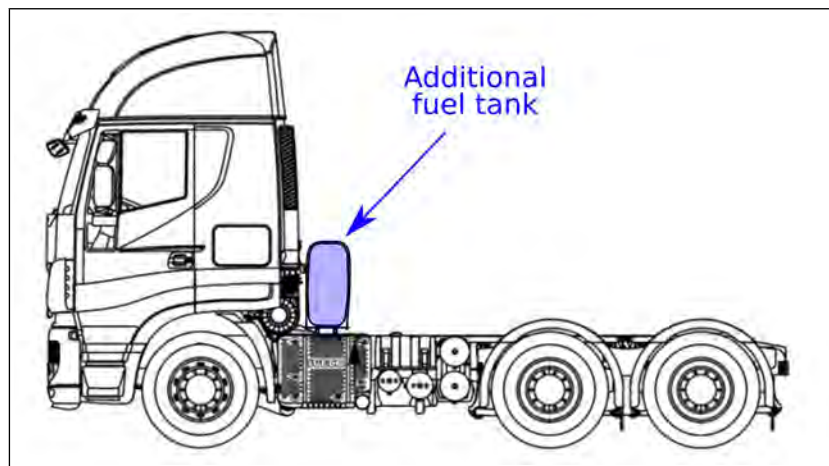
### 3.4.3.2 - Addition of an extra fuel tank

The tractor unit was equipped with an additional fuel tank with a capacity of 375 litres, increasing the vehicle's overall fuel capacity by 70%. This tank was made by a company called AFHYMAT, based in Roye, Somme (80), and was installed on the tractor unit in September 2014 by a garage in Orne (61).

The tank was fitted crosswise on the chassis of the tractor unit, behind the driver's cab. Its dimensions were as follows: 2.08 m in length, 0.65m in height and 0.32m in width. The tank was made from 3mm-thick 5754 H111 aluminium.

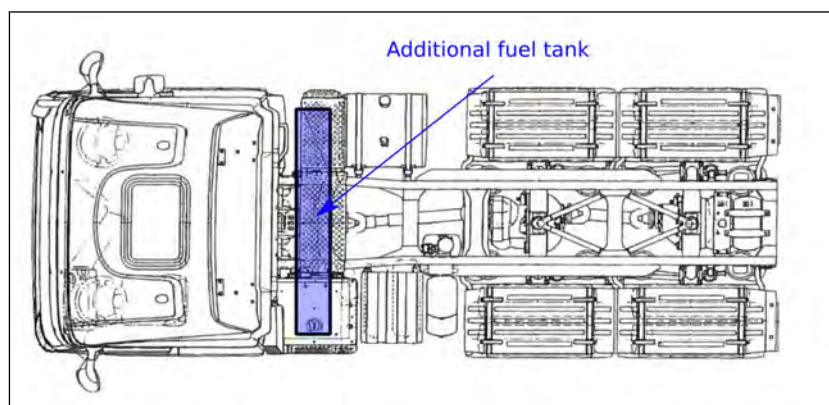
It was mounted on an independently-constructed support structure, using metal straps supplied by AFHYMAT. It was fitted with a vented fuel cap, an anti-siphoning device and a device to limit excess pressure in the tank to 0.2 bar. It was connected to the main fuel tank via metal tubing fitted with a solenoid valve.

The diagrams in figures 47 - 52 show the additional fuel tank on the tractor unit, as well as its exact position and layout.



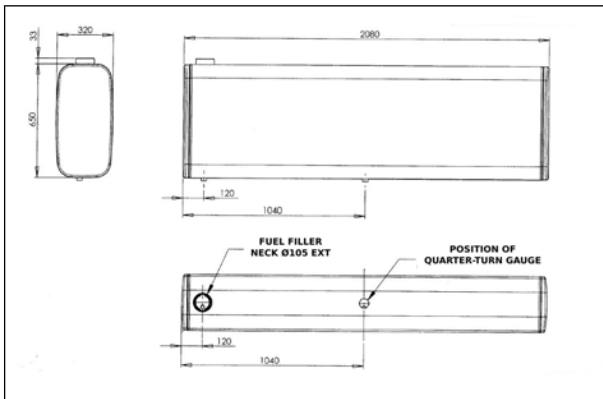
(Document IV annotated by BEA-TT)

**Figure 47: Position of the additional fuel tank to the rear of the cabin (side view)**



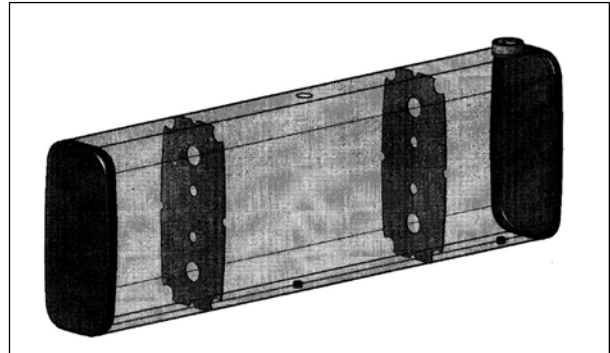
(Document IV annotated by BEA-TT)

**Figure 48: Position of the additional fuel tank to the rear of the cabin (top-down view)**



(document AF)

**Figure 49: Plan view of the additional fuel tank**



(document AF)

**Figure 50: Perspective view of the additional fuel tank**



(police photo.)

**Figure 51: View of the fuel tanks installed on the IVECO tractor unit involved in the accident**



(police photo.)

**Figure 52: View of the additional fuel tank on the IVECO tractor unit involved in the accident**

### 3.4.3.3 - Legal status of the additional fuel tank

The installation of an additional fuel tank is not considered a “major transformation” as indicated in Article R. 321-16 of the French Highway Code, and defined in Article 13 of the government decree issued on July 19th 1954 pertaining to the registration of motor vehicles. As such, vehicles modified in this way do not require a new registration in order to remain compliant with applicable regulations.

However, it is up to the installer (the person providing the vehicle modification service) to ensure that the modified vehicle remains compliant with regulations. This proof of compliance may take the form of a statement by the vehicle manufacturer indicating that the modification having been carried out is approved, or a testing report issued by a recognised vehicle testing laboratory.

When a vehicle manufacturer plans for the installation of such a component, either as standard or as an optional extra, they will approve the different variants for use with the vehicle. In this case, the manufacturer would chose an approved fuel tank as a separate technical component and approve its installation in accordance with existing European regulations.



This was not the case for the tractor unit involved in the accident, as its manufacturer (IVECO) had not approved the option of adding an additional fuel tank to the vehicle.

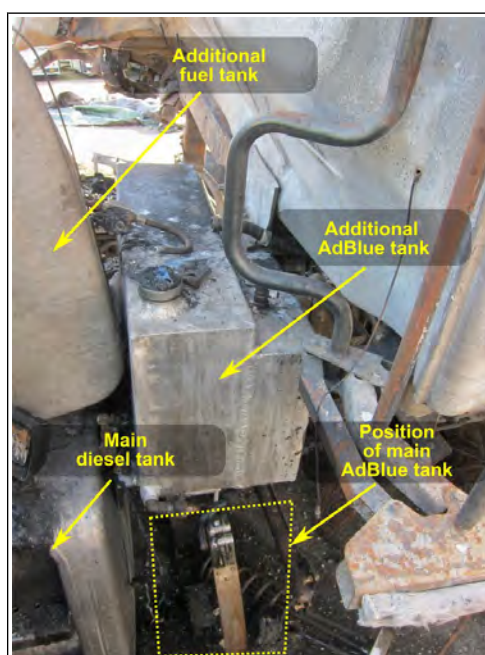
The additional fuel tank installed on the tractor unit was provided by a company named AFHYMAT. This company was unable to provide BEA-TT investigators with documentation indicating the tank's approval as a separate technical component, as the approval request was still being processed at the time of the BEA-TT's request. However, it should be noted that the model provided belongs to an approved product line of fuel tanks (TUTAC Report n° 02/07974 issued on November 22nd 2002), and that for the tank to be approved all that was required was an extension of the existing approval report.

In addition, none of the documents examined by the BEA-TT gave any indication of an approval request having been submitted for the installation of the fuel tank on this particular tractor unit.

In conclusion, neither the fuel tank nor its installation on the back of the tractor unit's cabin were officially approved at the time the accident occurred.

#### **3.4.3.4 - Addition of an extra AdBlue® tank**

An additional aluminium-alloy storage tank with a capacity of 72 litres was installed on the vehicle chassis behind the cabin (between the cabin and the additional fuel tank). It was positioned on the right-hand side of the tractor unit, above the original AdBlue® tank.



(BEA-TT photo)

**Figure 53: View of the additional AdBlue® tank**

It is made up of two compartments. Its dimensions were as follows: Length: 70 cm / Height: 42 cm / Width: 32cm

AdBlue® is an aqueous solution consisting of 32.65% urea and 67.5% demineralised water, and is non-flammable.

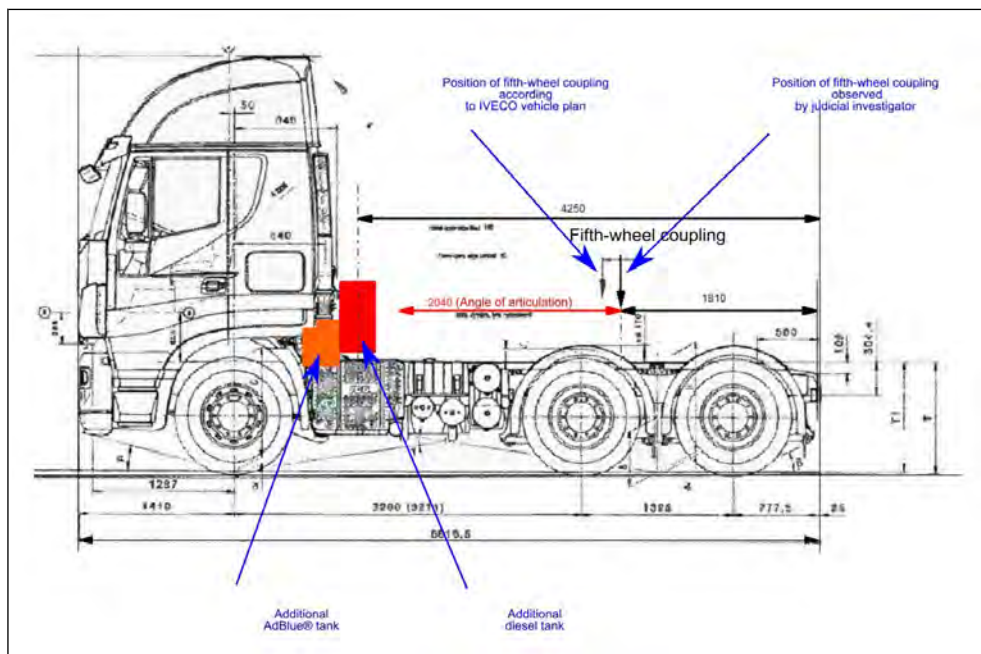
The documents examined by BEA-TT investigators did not give any information regarding the installation of this tank on the tractor unit.

### 3.4.3.5 - Rearward repositioning of the fifth-wheel coupling

Accounting for the addition of extra tanks behind the cab and the articulation angle of the trailer<sup>15</sup>, the fifth-wheel coupling of the tractor unit was moved back towards the rear of the vehicle, in order to leave sufficient space for the trailer's pneumatic and electrical connectors.

The original position of the fifth-wheel coupling was determined by the judicial expert in charge of vehicle assessments, with the aid of the tractor unit's technical design plans provided by its manufacturer (IVECO). The position of the fifth-wheel coupling on the wreck of the tractor unit allowed the investigator to estimate it had been moved backward by around 18cm.

Figures 54 and 55 below (taken from the judicial expert's report) show the original position of the fifth-wheel coupling and that measured during the post-crash analysis.



(document FB annotated by BEA-TT)

**Figure 54: View of the fifth-wheel coupling positioned in accordance with the distance measured**

<sup>15</sup> The articulation angle of the trailer equates to the distance between the coupling pivot and the front corners of the trailer.





The vehicle had the following technical characteristics:

- length: 13.26m;
- width: 2.55m;
- curb weight: 7.2t;
- a GVWR of 34t, raised to 44t for journeys properly authorised in accordance with the stipulations of Article R. 433-1 of the French Highway Code.



(BEA-TT photo)

**Figure 56: View of the BILLAUD semitrailer involved in the accident (BEA-TT photo)**

### **3.4.5 - Assessment of the Tractor Unit**

#### **3.4.5.1 - Presumed condition of the tractor unit before the accident**

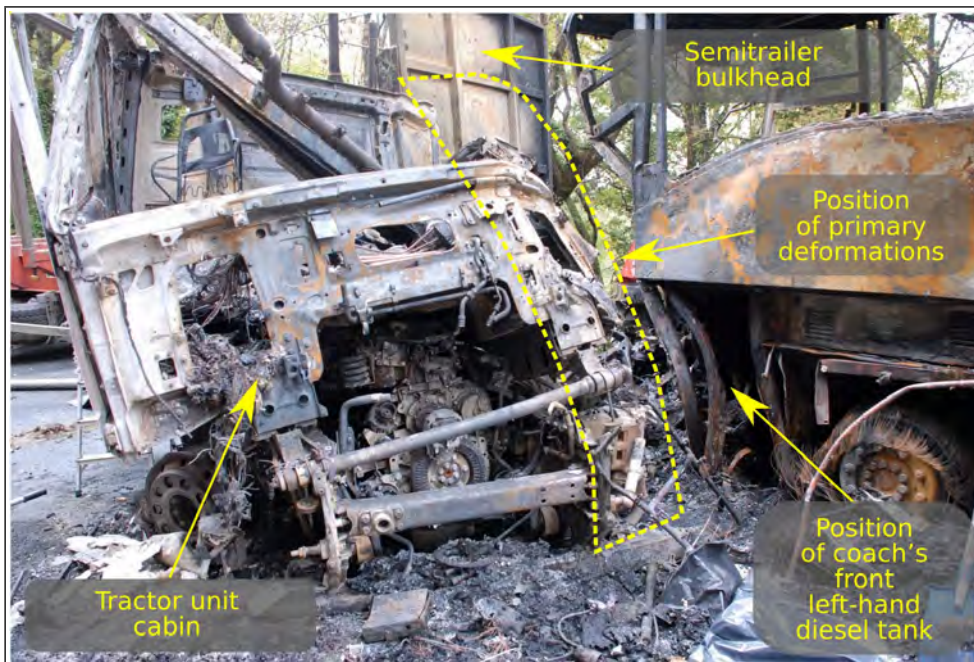
The examination of the vehicle, particularly the remnants of tyre treads and brake discs/pads that were left intact or partially intact after the fire, showed that the tractor unit was in good condition.

The assessment did not show any internal failure in the tractor unit that might have caused it to malfunction in the moments leading up to the crash.

#### **3.4.5.2 - Damage to the tractor unit**

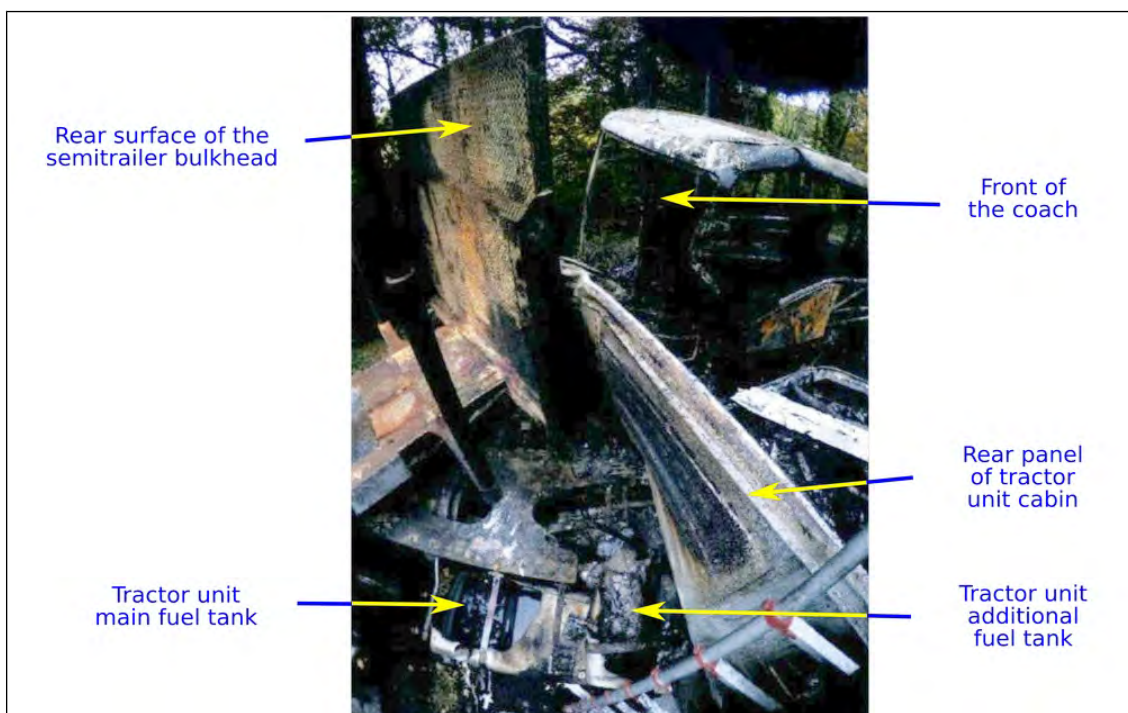
The tractor unit was completely destroyed by the fire that broke out following the collision. Almost all flammable materials were consumed, leaving only small amounts of unusable residue. A number of pieces of aluminium alloy were wholly or partially melted by the heat of the fire.

The tractor unit showed signs of localised crushing on its front left-hand corner, with the structures having been collapsed inwards. The driver's cabin was partially collapsed. The left hand side of the cab's rear panel was pressing against the front bulkhead of the semitrailer.



(police photo)

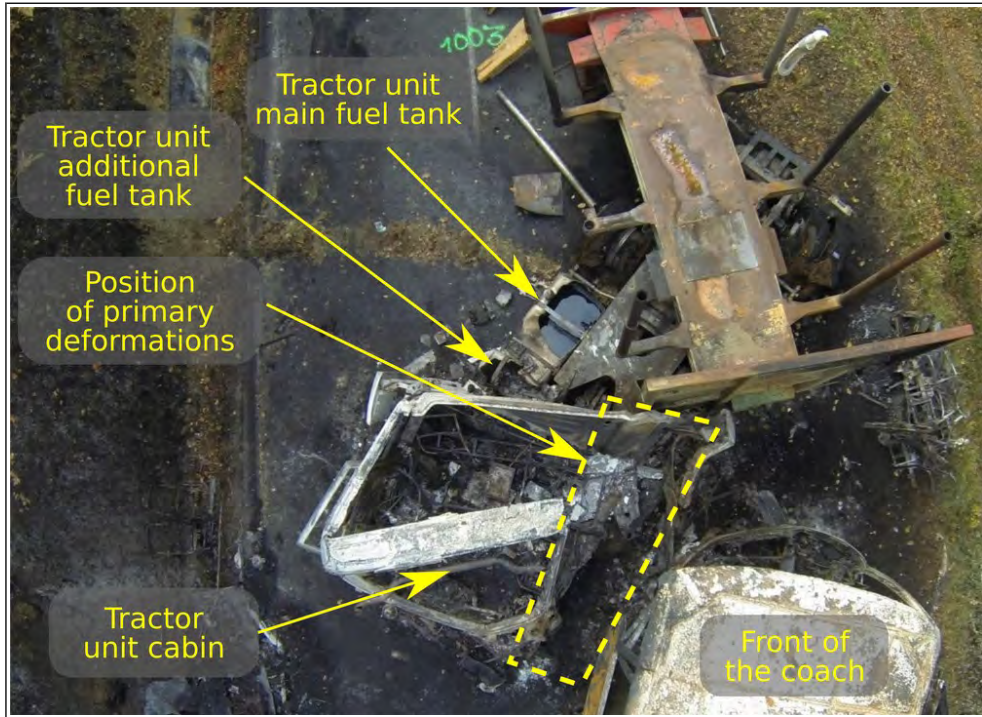
**Figure 57: Front view of the tractor unit involved in the accident**



(police photo)

**Figure 58: Rear view of the tractor unit involved in the accident**

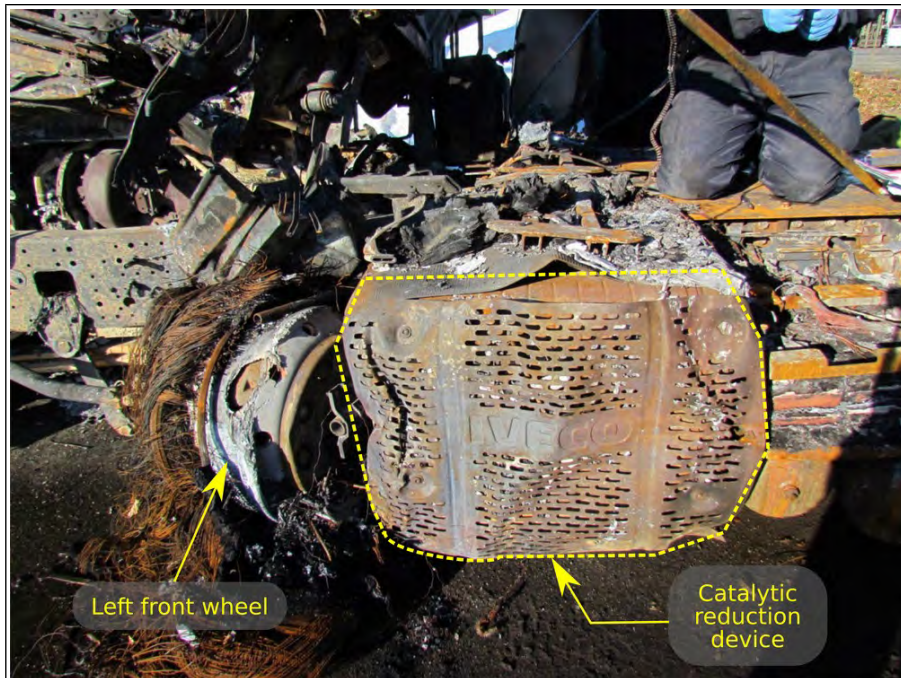




(XG dronephoto)

**Figure 59: Aerial view of the tractor unit involved in the accident**

The front left-hand axle was forced back by the impact, and the left front wheel was pushed back against the tractor unit's catalytic reduction system, colliding with and damaging the device.

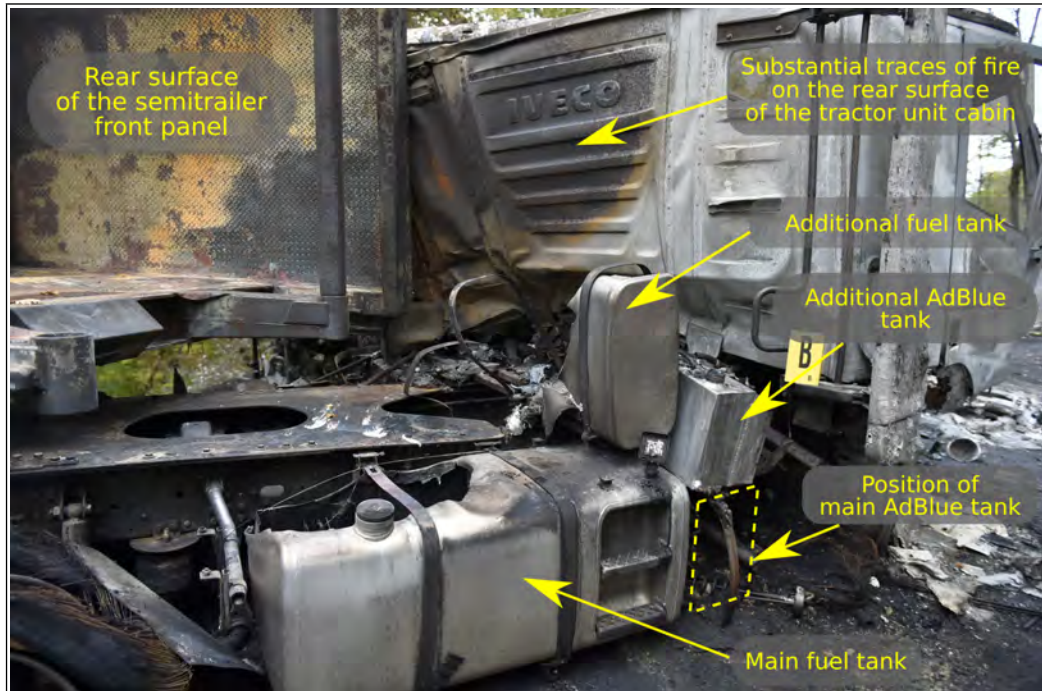


(CL photo)

**Figure 60: View of the front left wheel of the tractor unit, pushed back against the catalytic reduction device**

The lower portion of the steering unit cracked open, releasing some of the oil contained inside (oil type ATF DEXRON II D).

Due to the extent of the damage caused by the fire, BEA-TT investigators were unable to determine whether, at the moment of impact, a rupture of the engine lubrication and cooling circuits, as well as the air conditioning circuits and clutch control, occurred.

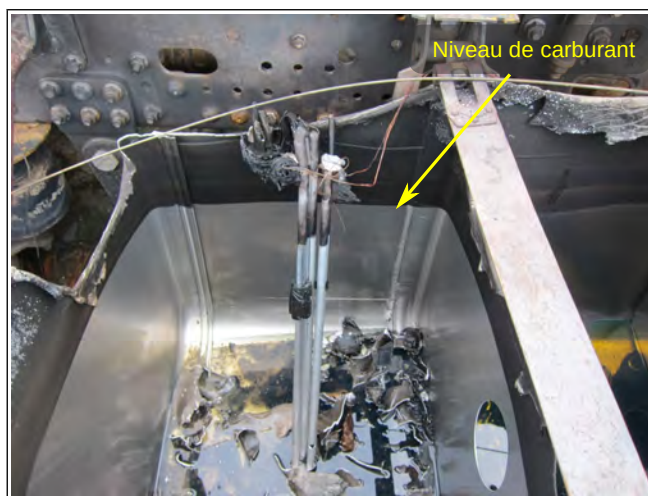


(police photo)

**Figure 61: View of the right-hand side of the tractor unit involved in the accident**

The primary fuel tank was partially melted. Traces indicating the level of liquid the tank contained were visible on the tank's interior after the fire had been extinguished. They were situated around 3/4 of the way up the tank.

Figure 62 below shows these traces on the inside of the main fuel tank.



(BEA-TT photo)

**Figure 62: View of the traces of liquid on the interior of the primary fuel tank of the tractor unit involved in the accident**

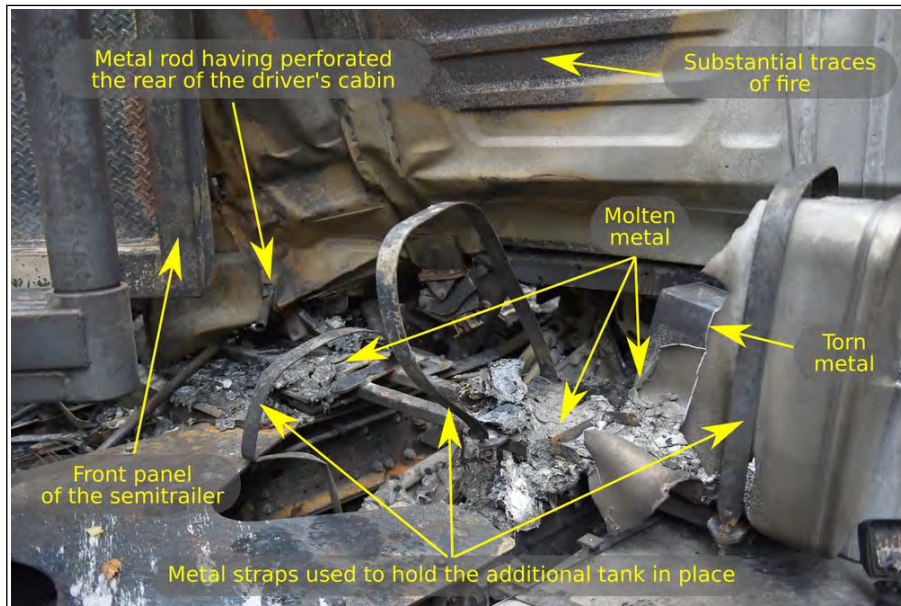


The additional fuel tank was almost completely melted. Only its right-hand side, support structure and the metallic straps holding it in place survived the fire. The right-hand side of the tank showed traces of molten metal and signs of metal splitting.

No liquid level was visible on the walls of the additional tank.

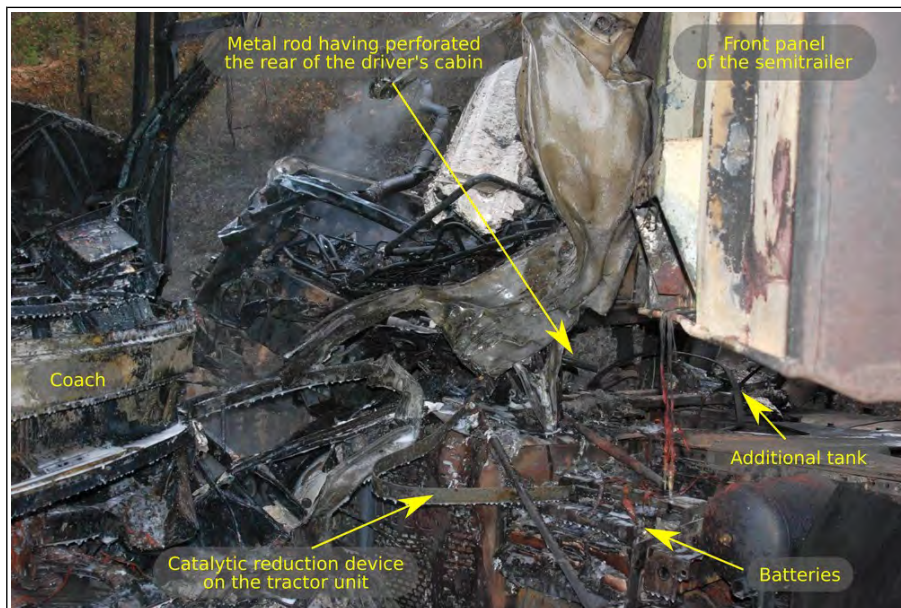
The rear side of the driver's cab showed major signs of localised fire, mainly on its left-hand side.

A metal rod, which had been stored in a boot space on the left-hand side of the driver's cab, perforated the rear of the cab; one end of the rod was found where the additional fuel tank had been, in a position that led investigators to surmise that it had partially perforated the tank.



(police photo)

**Figure 63: Close-up view of the additional fuel tank on the tractor unit involved in the accident**



(police photo)

**Figure 64: View of the left-hand side of the tractor unit involved in the accident**



(police photo)

**Figure 65: Close-up view, from the rear of the tractor unit, of the metal rod that passed through the rear wall of the cab**



(police photo)

**Figure 66: Close-up view, from the front of the tractor unit, of the metal rod that passed through the rear wall of the cab.**

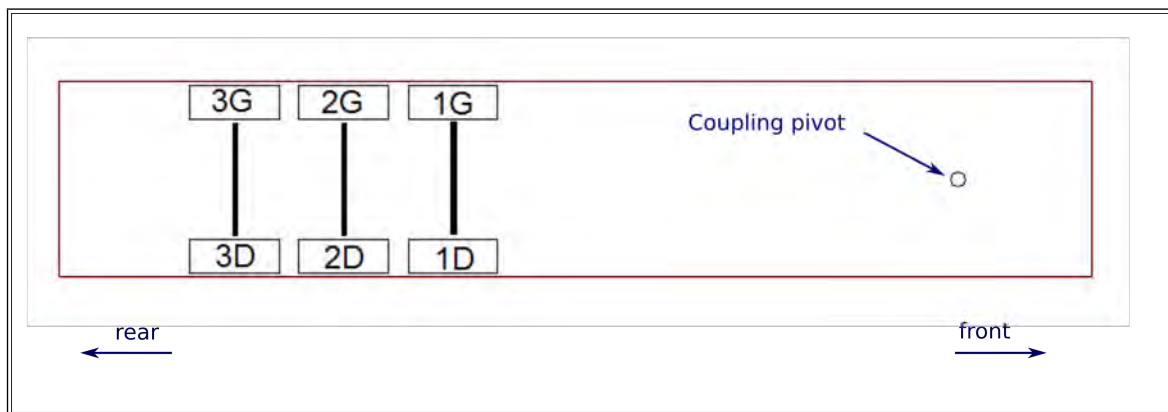
### 3.4.5.3 - Analysis of data recorded by the tractor unit's tachograph

The tractor unit's tachograph was completely destroyed by the fire. Investigators were therefore unable to carry out any examination of the data recorded by this device.

### 3.4.6 - Expert analysis of the semitrailer and its components

#### 3.4.6.1 - Tyres

The vehicle was connected to the road via six tyres and three axles. The tyres were positioned according to the diagram below.



(FB document FB annotated by BEA-TT)

**Figure 67: Position of tyres on the semitrailer**

The semitrailer's tyres were slightly worn. Their dimensions are in compliance with approved limits, and the tyre pressure was correct.

Isolated abrasions on the tyre treads were observed on tyres 1D and 2D, whose shape corresponds approximately to the area where the tyre met the road surface. The abrasions on these tyres can be matched with the tyre tracks caused by slippage observed on the road surface (cf figure n° 9).



These tyre abrasions are visible in figures 68 and 69 below.



(CL photo)

**Figure 68: Abrasions on the tyre treads of tyre 2D.**



(FB photo)

**Figure 69: Abrasions on the treads of tyre 1D**

#### **3.4.6.2 - Coupling**

No anomalies were observed on the vehicle's coupling pivot. Examinations carried out following the accident showed that the semitrailer remained coupled to the tractor unit.

#### **3.4.6.3 - Suspension**

No irregularities were observed on the vehicle's suspension.

#### **3.4.6.4 - Braking**

The semitrailer was equipped with disc brakes on each wheel, activated by a pneumatic system fitted with an anti-lock braking device (ABS).

Measurements of thickness of the brake pads and discs showed no irregularities.

However, an examination of the braking system did show several issues, summarised below:

- significant cracking in the brake discs on wheels 1G, 1D and 3G;
- brake protection discs were eroded and perforated by corrosion, or missing, on wheels 1G, 1D, 3G and 3D;
- the brake clamp devices were defective or unusually worn on wheels 1D, 2D, 3G and 3D;
- the second brake fluid reservoir was severely corroded;
- the ABS sensors were the wrong way round on the right wheels of axles 1 and 3,
- insufficient braking efficiency on the right wheels of axles 1 and 2 was observed following the accident.

The analysis of the consequences of these issues led the judicial expert to surmise that once the semitrailer's ABS had been activated, the braking power was only sufficient on the vehicle's left-hand side; this imbalance caused, at the level of the coupling pivot, a resulting force towards the outside of the bend, pushing the rear of the tractor unit in this direction, and thereby either causing or exacerbating the jack-knifing of the lorry.

The operational procedures for technical inspections currently do not allow for the detection of inversely-installed ABS sensors. However, modifications introduced by a government Decree issued on June 8th 2017 will make such detection possible as of May 20th 2018 (the date on which the Decree takes effect).

### 3.4.6.5 - Damage to the semitrailer

The semitrailer shows damage caused partly by the impact with the rear panel of the tractor unit, and partly by the fire that broke out following the collision.

The damage to the semitrailer caused by the impact with the rear of the tractor unit's cabin was localised around the upper portion of the trailer's front panel, which was pushed backwards.

The fire destroyed part of the semitrailer, along an area extending from the front panel to the stabilisers. The combustible materials found in this zone were burned in the fire. This includes electrical cable casings and the tubing for the pneumatic braking system. Components made of aluminium alloy in this zone also melted or disappeared.

The second trailer<sup>17</sup> post on the right-hand side of the vehicle fell onto the road, as a result of its support structure giving way.



(CL photo)

**Figure 70: View of the right-hand side of the semitrailer involved in the accident**

## 3.5 - Kinematic reconstruction of the accident

Upon the request of the Assistant Public Prosecutor from the high court of Libourne, a kinematic reconstruction of the accident was compiled by an accident expert using PC-Crash© analytical software.

<sup>17</sup> Post (steel or aluminium) found on the perimeter of the semitrailer's loading panel.

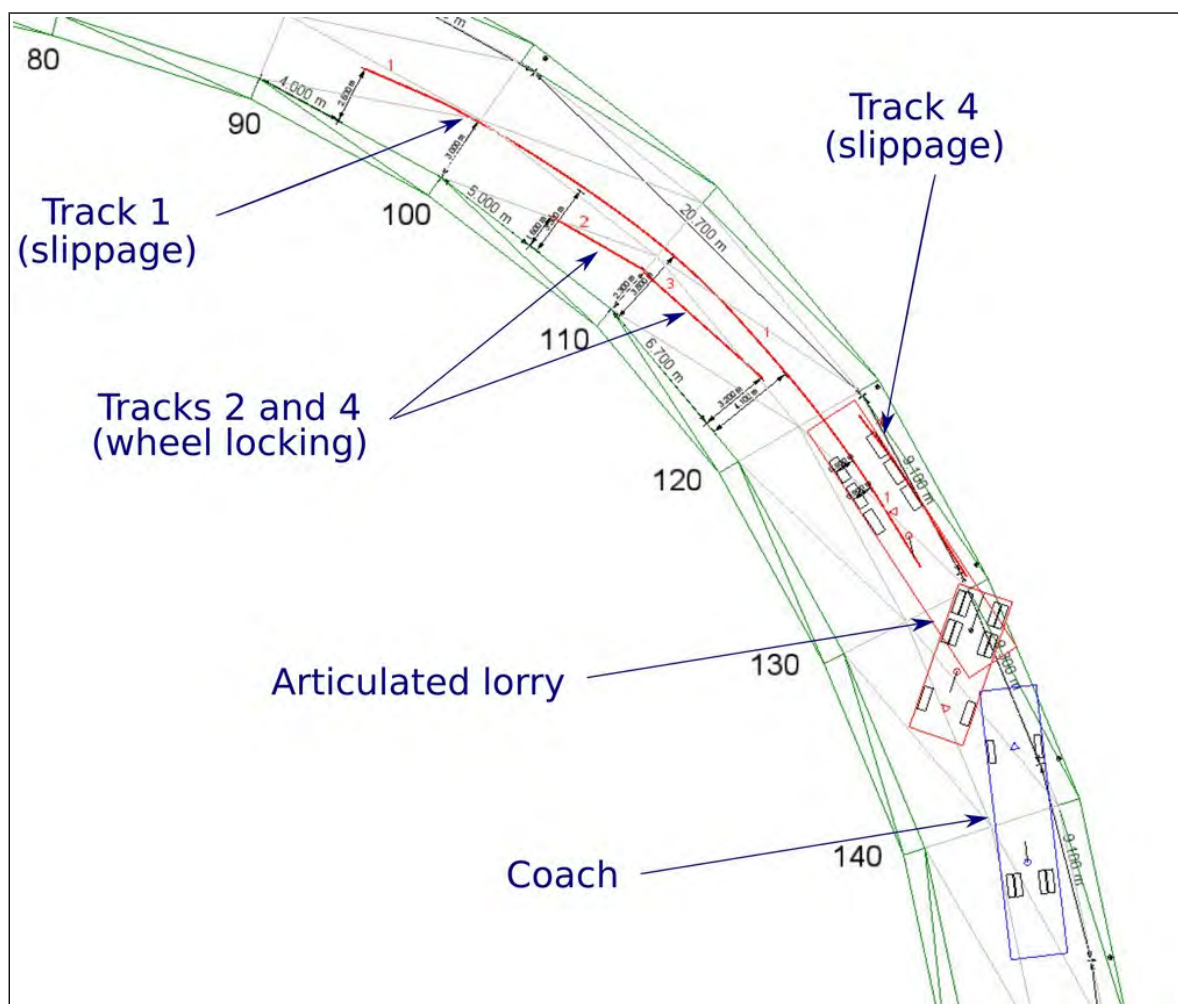
The theories posited by the judicial expert and the conclusions of this reconstruction are presented below. The figures illustrating the conclusions are also drawn from the digital simulation which was compiled for the investigation.

However, it must be underlined that the vehicles' initial speeds, as well as their speeds at the time of impact, are only estimates calculated by the software based on theoretical information gathered by the vehicle expert, and that investigators were not able to gather any solid information regarding the vehicles' speeds from the on-board speedometers or tachographs, as these devices were completely destroyed in the fire.

The positions and speed of the vehicles in the moments leading up to the crash, and at the moment of impact, have been reconstituted based on vehicle characteristics, road surface modelling, the positions in which the vehicles were found, analysis of tyre tracks found on the road surface, and identification of the points of impact and directionality of the collision.

### 3.5.1 - Final position of vehicles and tyre tracks on road surface

Traces of tyre slipping and wheel locking, as well as the final position of the vehicles, are shown in figure 71 below, as well as in figures 4, 8 and 9.



(CL document annotated by BEA-TT)

**Figure 71: Representation of tyre tracks found and final position of the vehicles at the scene of the accident**



Please note: the simulation software retains the dimensions and shapes of the vehicles. As such, these representations do not show damage and deformations caused by the collision.

The position and type of tyre tracks found (slipping and wheel locking) allowed BEA-TT investigators to observe:

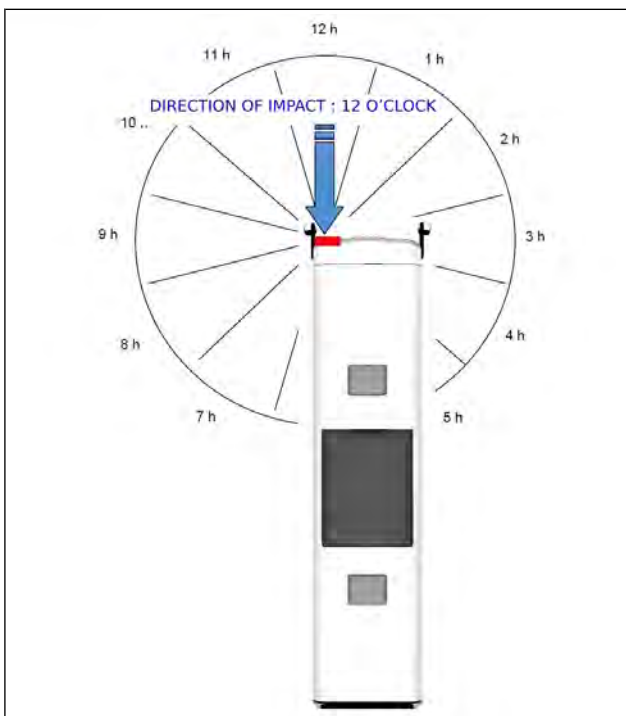
- assuming that the lorry was travelling in its own lane, that track 1, which begins furthest away from the accident, corresponds to slipping of one of the lorry's left wheels,
- that this track, which shows continuous slipping and continues beyond the wheels of the semitrailer, was left by a left wheel of the tractor unit;
- that tracks 2 and 3 were most likely caused by locking of wheels 1D and 2D of the semitrailer, given the abrasions observed on their tyres;
- that track 4, which appears beyond the wheels of the semitrailer, was caused by the slipping of one of the tractor unit's wheels. Taking into account its proximity to the road edge, it was mostly likely left by one of the tractor unit's left rear wheels.

### 3.5.2 - Identification of impact points and directionality

Based on the examination of damage to the vehicles, the expert made the following observations.

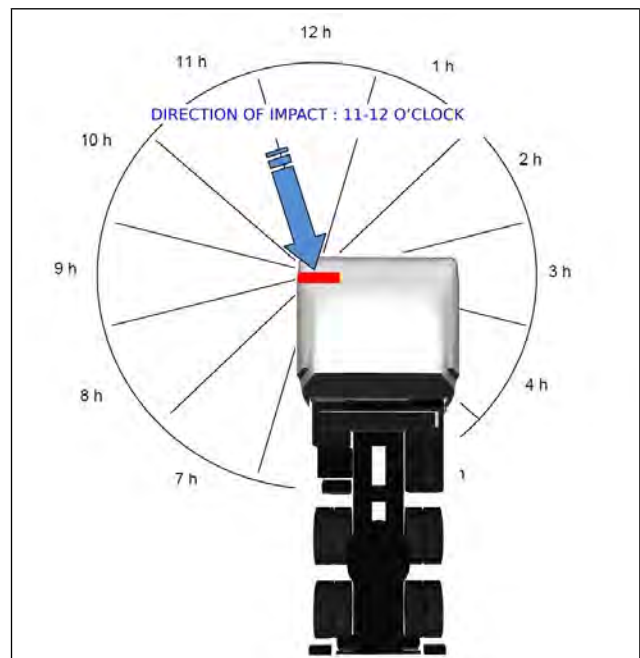
The tractor unit showed signs of frontal impact on roughly 1/4 of its front left-hand side; the primary direction of the force exerted on the vehicle being roughly between 11 o'clock and 12 o'clock.

The coach shows signs of front impact on around 1/4 of its front left-hand side; the primary direction of the force exerted on the vehicle being at roughly 12 o'clock.



(CL document)

**Figure 72: Direction of impact on the coach**



(CL document)

**Figure 73: Direction of impact on the tractor unit**

### 3.5.3 - Vehicle 3D Modelling

The geometry of the articulated lorry was calculated using the values provided by its manufacturer. In the event that any measurements did not match, the investigating expert used his own measurements taken at the scene.

The geometry of the coach was calculated using the values provided by its manufacturer. These were in accordance with the measurements taken by the investigating expert.

The position of the fifth-wheel coupling on the articulated lorry, as well as the centres of gravity for each vehicle, were determined by the investigating expert using data provided by the manufacturers, supplemented by measurements taken over the course of various assessments of the accident.

### 3.5.4 - Results

The expert tested various movement scenarios for each vehicle in order to reproduce their kinematics and trajectories in the moments leading up to the impact. These scenarios were configured in such a way as to accurately represent the braking performance of the articulated lorry, its passage through the tyre tracks observed, its jack-knifing just before impact, the configuration of the collision, the final position of the vehicles and estimated energy dissipation.

The scenario which best represented these fixed values was retained.

The results obtained were as follows:

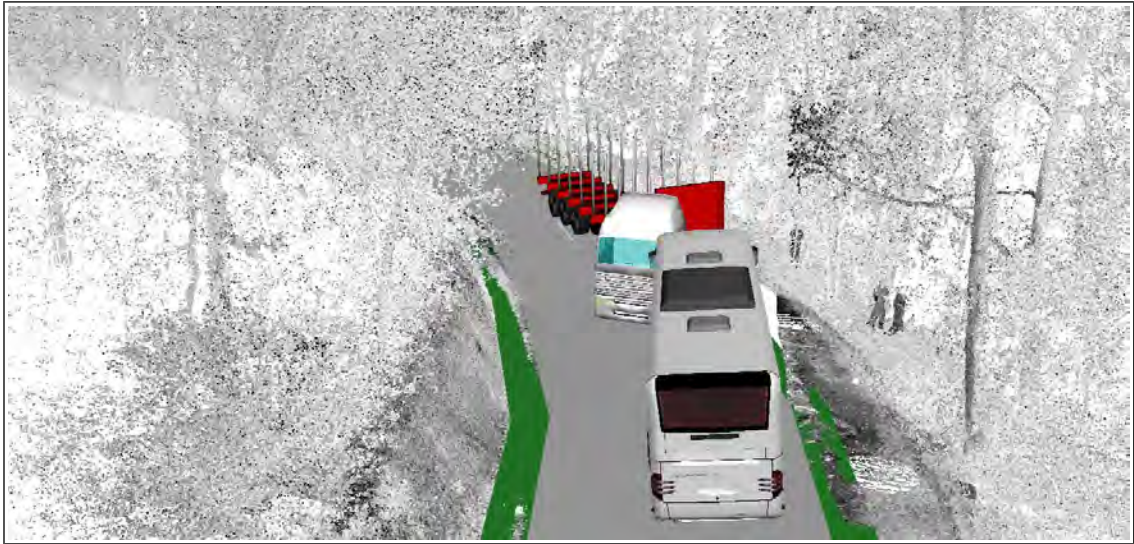
- the initial speed of the articulated lorry was around 75km/h, slowing to around 35km/h at the moment of impact;
- the initial speed of the coach was around 45km/h, slowing to 15km/h at the moment of impact.

The positions of the vehicles (according to 3D modelling based on the reconstruction of the accident) at the moment when the coach driver first saw the articulated lorry when the two vehicles were at least 40m away from each other, and then at the moment of impact, are shown in figures 74 and 75 respectively.



(CL document)

**Figure 74: Position of the vehicles at  $t = 4.50$  s, at the moment when the coach driver first saw the articulated lorry.**



(CL document)

**Figure 75: Position of the vehicles at the moment of impact ( $t = 6.275$  s) according to the kinematic reconstruction.**

The simulation allowed BEA-TT investigators to gain an appreciation of the speed at which each vehicle was travelling, but it remains difficult to show how precise this information is.

Nevertheless, analysis of the tracks left by tyre slipping on the road surface have allowed BEA-TT investigators to conclude that they were caused by the articulated lorry drifting due to dual forces: a significant centrifugal force caused by excessive speed going into the bend, and locking of the driving wheels towards the right as the vehicle attempted to avoid going off the road.

### 3.6 - Outbreak and spread of the fire

Various theories regarding the outbreak and spread of the fire inside the coach have been put forward by the different parties involved in the judicial inquiry into the accident.

The main theory (upheld by the fire expert in his report dated January 24th 2016) is that a spray of diesel was generated when the additional fuel tank (located behind the tractor unit's cabin) was pressurised during the crash impact and then perforated by a metal rod. This spray was immediately ignited upon contact with an unidentified heat source, and the resulting "fireball" then penetrated the interior of the coach via the opening created by the shattering of side windows on the front left-hand side of the coach, near the driver's position.

The report also pointed to the bursting of heating and air conditioning pipes located at the front of the coach, which then released coolant and refrigerant fluids onto the area of overlap between the coach and the tractor unit; however, the role played by the projection of these fluids in the outbreak and spread of the fire has not been fully analysed.

The judicial expert responsible for analysing the vehicles observed that the coach's left fuel compartment was severely damaged during the collision, leading to an unexpected compression of the polyethylene fuel tank inside. His analysis did not examine this point further, but did recommend that additional investigations be carried out in order to identify the behaviour of the coach's fuel tanks under the pressure generated by the collision.

The judicial expert responsible for examining the vehicles also observed that a rupture in the tractor unit's transmission could have led to a leak or projection of transmission fluid. He also concluded that, given the magnitude of the damage observed on the tractor unit, a rupture or ruptures of the radiator and cooling pipes, the air conditioning system and the hydraulic clutch circuits might have occurred during the impact. The fluids released by this type of damage could also have played a role in the outbreak and /or spread of the fire.

The analyses carried out and the theories retained by the BEA-TT investigators are presented in the next part of this chapter.

According to witness statements taken, the vehicles involved in the accident were both in operation and collided with their engines running. All the circuits (fuel, lubrication, cooling, air conditioning and electronics) in their respective engines were live when the accident occurred; depending on their individual states, these circuits all represent potential sources of the fire or may have helped to spread it.

### **3.6.1 - Fuel supply sources**

In the area of impact between the two vehicles or in the immediate vicinity there are several potential fuel supply sources, in particular:

- the main fuel tank of the tractor unit;
- the tractor unit's additional fuel tank located behind the driver's cab, above the exhaust line;
- the tractor unit's steering unit, which contained an ATF DEXRON II D type of oil;
- the lubricating and cooling systems of the tractor unit's engine;
- the tractor unit's air conditioning;
- the coach's left fuel tank
- the coach's air conditioning system and in particular the evaporator installed in front air-conditioning unit, in which the refrigerant enters in a liquid state under high pressure;
- the coach's heating system and in particular the radiator installed in the same front unit in which the refrigerant circulates.



The main fuel tank of the trailer truck was partially melted. It was not located in the direct area of impact. It was not distorted. The damage it suffered is as a result of the fire's thermal radiation.



(photo French Gendarmerie.)

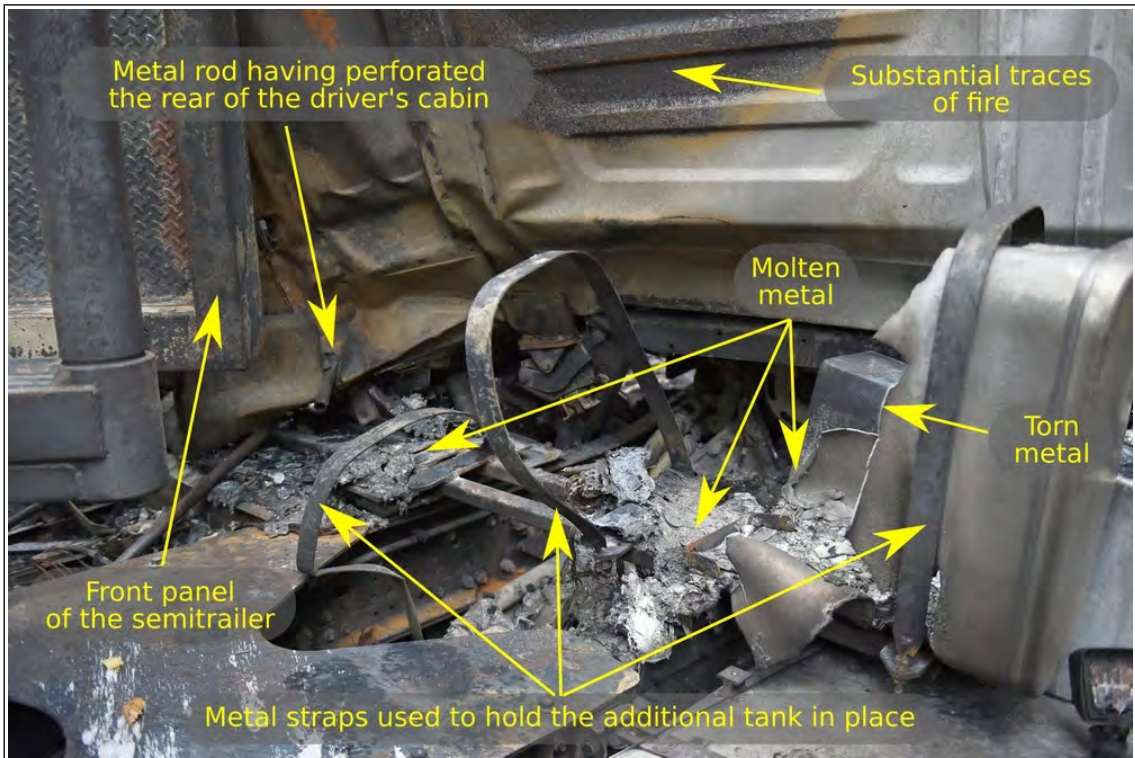
**Figure 76: View of the diesel fuel tanks of the accident-damaged tractor unit**

The articulated lorry's additional fuel tank was directly hit during the collision.

The observations made by the BEA-TT on the remains of this tank are the following:

- the tank has almost completely melted, only its right part, its support and the metallic tie-down straps have been preserved from the fire;
- the location of the traces of molten aluminium found on the chassis of the tractor unit as well as the condition of the tank's metallic tie-down straps show that the left part of the tank pivoted backwards before melting;
- the right part of the intact tank has traces of melting as well as traces of tearing of the metal;
- the left side of the tank located at the metal rod that perforated the rear of the driver's cab has melted.

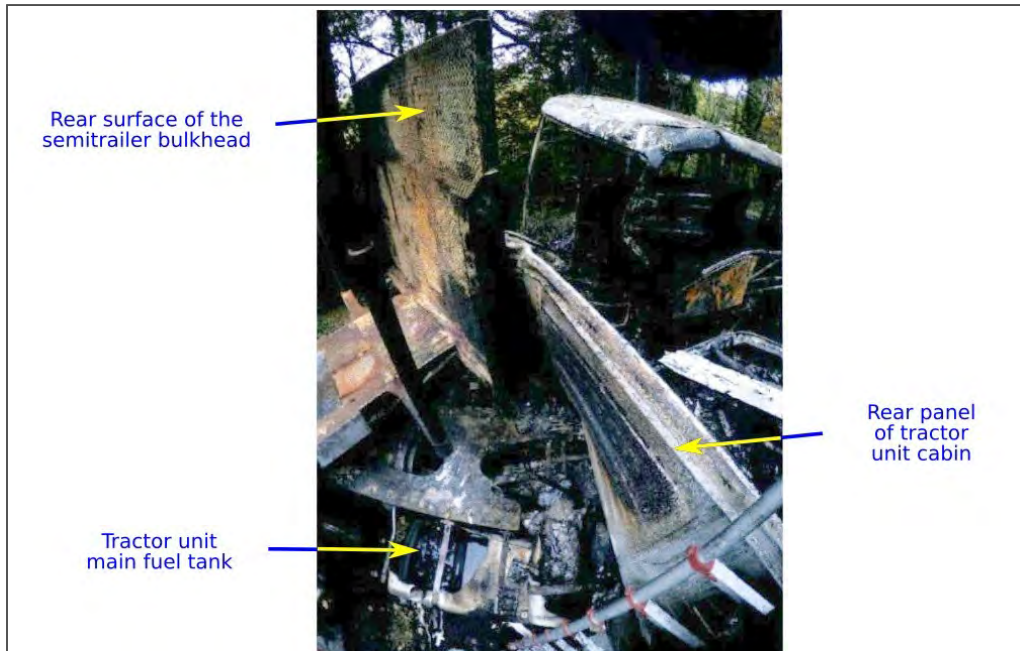




(police photo.)

**Figure 77: View of the additional tank of the accident-damaged tractor unit**

Given the deformations observed on the tank and the position of the driver's cab of the tractor unit, which was found by the front panel of the semi-trailer, the BEA-TT thinks that this tank was most likely broken upon impact, crushed between the rear of the semi-trailer's cab and front panel, releasing its fuel.



(police photo.)

**Figure 78: Rear view of accident-damaged tractor unit**

This tank could have also be perforated by a metal rod which was stored in a trunk in the driver's cab of the tractor unit. This metal rod in fact perforated the rear of the driver's cab and its rear part was found at a location where the additional tank had been installed and in a position suggesting that it could have partially penetrated it.

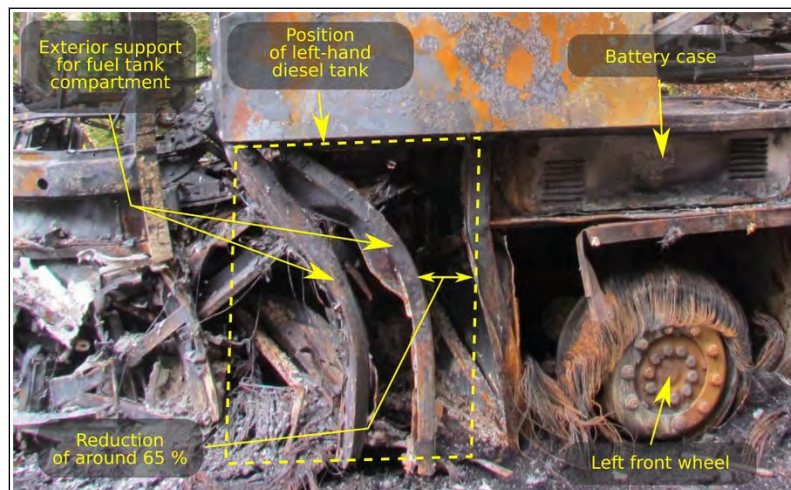
For the BEA-TT investigators, the highly probable rupture of this tank and the existence of an anti-overpressure plug are not compatible with the hypothesis of the pressurisation of the fuel it contained, which would have been capable of generating a diesel oil nebulisate.

**The left fuel tank of the coach** is made of polyethylene and has been completely burned. There are no usable parts left. This tank was located in the direct area of impact in which the metal structures of the coach which protected it were extensively crushed. It is therefore very probable that this tank did not withstand the impact and that it broke during the collision, releasing its fuel which then spread to the ground.



(police photo.)

**Figure 79: View of the left front of the accident-damaged coach**



(photo CL)

**Figure 80: Close-up view of the front left-hand side of the coach involved in the accident**



**The air conditioning components of the coach** that contained the refrigerant in liquid phase under pressure do not appear to have been directly impacted during the collision, but were damaged by the resulting fire. It is therefore very probable that the refrigerant contained in them, in this case R134a, which is furthermore very difficult to ignite, did not play a role in triggering the fire.

**The heating system components of the coach** situated in the front housing do not appear to have been directly impacted during the collision, but were damaged by the resulting fire. It is therefore very probable that the liquid contained within them, namely Glystantin G48, which is furthermore difficult to ignite, did not play a role in triggering the fire.

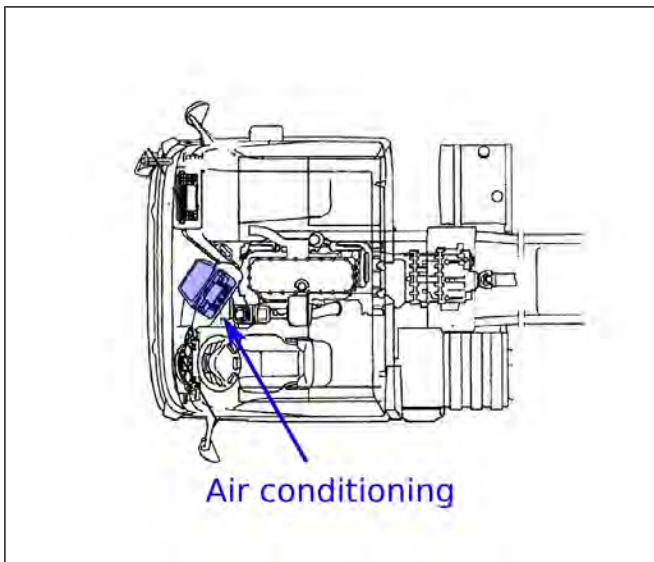


*(police photo.)*

**Figure 81: View of the front face of the accident-damaged coach**

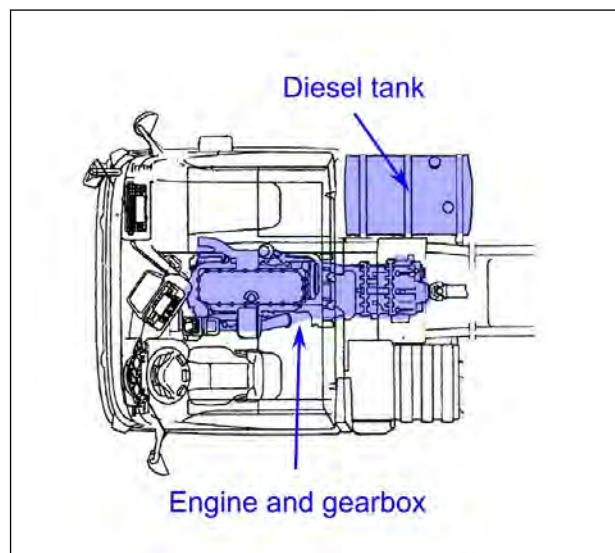
The mechanical components of the tractor unit were severely damaged by the fire which started after the collision, and apart from the steering unit which broke at the moment of impact, releasing some of the oil it contained, it was not possible for the BEA-TT investigators to determine whether other mechanical components of this tractor unit broke during the collision.

It should be noted, however, that the tractor unit's air conditioning system containing the liquid-phase pressurised refrigerant, the engine, the gearbox and the cooling system containing various potentially flammable fluids do not appear to have been impacted during the collision, but were rather damaged or destroyed by fire.



(Document IV annotated by BEA-TT)

**Figure 82: Layout of the tractor unit's air conditioning unit in the cab (top view)**



(Document IV annotated by BEA-TT)

**Figure 83: Layout of the tractor unit's engine, gearbox and tank (top view)**

### 3.6.2 - The heat source at the origin of the blaze

In the area of impact between the two vehicles, or in close proximity, there are numerous electrical systems as well as significant heat sources, in particular:

- the highway tractor's exhaust system was designed to meet the Euro 6<sup>18</sup> standard and can reach high temperatures of several hundreds of degrees due to the temperature of the exhaust gas at the immediate exit of the engine;
- the device for selective catalytic reduction fitted to the tractor unit;
- the coach's electrical panel located at the front left between the pressure taps and the front left fuel tank;
- the batteries of the coach and of the tractor unit.

It should also be pointed out that during the collision, the crushing or friction of various metal parts of the vehicles against each other or on the surface of the road could have generated active sources capable of igniting a fuel present in the vicinity that had also been heated previously by coming into contact with the hot parts of the vehicles.

The BEA-TT inspected the remains of the coach's electrical panel located at the front left, in front of its left fuel tank and did not find any melted parts on the remains of the electrical wires, which are characteristic of a short circuit. It also inspected other electrical and heat sources that could have played a role in triggering the fire but was unable to formally identify a source for the origin of the fire.

### 3.6.3 - The hypothesis concerning what triggered the fire and caused it to spread

BEA-TT investigators point out that the significant damage to the vehicles limited the possibilities for investigations, and it is therefore not possible to determine with absolute certainty what caused the fire to start and spread so quickly.

<sup>18</sup> European emission standards known as "Euro standards", are the European Union regulations which set the maximum polluting emission limits for motor vehicles

Given its investigations and analyses presented in the previous paragraphs, after examining the various hypotheses mentioned, the BEA-TT favours the following scenario, which it deems to be the most plausible.

Upon impact, the tractor unit's additional tank and the coach's left tank broke and spread their contents on both vehicles and the roadway.

The contents of the additional tank located behind the driver's cab spread over the rear of the cab and on the mechanical components of the tractor unit underneath it. It spread in particular over the exhaust line and the catalytic reduction device, which are heated to very high temperatures during operation. This may have led to heating and partial vaporisation of the diesel oil.

The diesel oil contained in the coach's left tank spread over the road and flowed towards the tractor unit, following the slope of the road.

The active heat source responsible for the blaze could not be formally identified, but perhaps the crushing or friction of the various metallic and electrical components of the vehicles against each other or on the roadway were able to generate active heat sources that could have ignited the diesel oil and its fumes. This could have easily happened as the latter could have been preheated and vaporised upon contact with the tractor unit's exhaust line and selective catalytic reduction device.

Given the volume of these two tanks, although we do not know how full they were at the time of the accident, it can be assumed that several hundred litres of fuel spread and became ignited. The flames then spread under the tractor unit to the coach's tanks and entered the coach through the front left windows on the driver's side that had broken at the time of the collision.

Given the calorific value of this fuel and the amount involved, the fire quickly spread to the coach, melting and igniting its interior fittings, consisting mainly of ABS<sup>19</sup>, polypropylene, polyester and polyurethane. The hot fumes and the highly toxic combustion gases that were released and quickly spread from the front to the back of the coach contributed to the conflagration of the coach.

The fire quickly became uncontrollable.

### **3.7 - Current regulations for public transit vehicles in terms of layout, fire risk and design of exits**

In general, the vehicle regulations applied to a vehicle are those applicable on the date of its entry into service. The various regulations are constantly evolving.

The global technical harmonisation of vehicles is guided by a founding international agreement which establishes harmonised provisions on a worldwide scale guaranteeing in particular a minimum degree of safety.

This is the agreement of the United Nations Economic Commission for Europe (UNECE) on the adoption of uniform technical requirements for motor vehicles, equipment and parts that may be fitted or used on a motor vehicle and the conditions for mutual recognition of approvals issued in accordance with these requirements, commonly known as the "*revised 1958 Agreement*". VARIOUS UN regulations are annexed to this agreement, as well as the list of the contracting parties that signed them.

---

19 ABS or acrylonitrile butadiene styrene is a thermoplastic polymer that is often used in automotive construction.



Under the 1958 Agreement, a Contracting Party applying one or more of the UN Regulations annexed to the Agreement shall be entitled to grant type approvals for vehicles, their equipment and components referred to in those Regulations and shall accept the type approval of any other Contracting Party which has adopted the same Regulations.

The reciprocal recognition of type approvals between the Contracting Parties who implement the regulations facilitates the trade in vehicles on the international market.

This global regulation is transposed at the European Level by various European regulations and directives and at the national level in France by the amended decree of 2 July 1982 on the public transport of persons with regard to the part relating to the construction and layout of public transport vehicles.

Other regulatory areas (such as braking and noise level) are transposed by specific national regulations and more generally by the decree of 4 May 2009 on type approval of motor vehicles, their trailers and systems and equipment intended for such vehicles pursuant to Directive 2007/46/EC.

The regulation of the European Parliament and of the Council regarding the areas analysed in this report is regulation no. 661/2009 of 13 July 2009 as amended regarding the type approval requirements for the general safety of motor vehicles and their trailers and systems, components and separate technical units intended for them.

In particular, regulation no. 661/2009 repealed, with effect from 1 November 2014, the following three European Directives which were applicable for the EC type approval of new vehicles:

**Provisions concerning all motor vehicles:**

- Directive 70/221/EC of 20 March 1970 on the approximation of the laws of the Member States relating to liquid fuel tanks and rear protective devices for motor vehicles and their trailers (amended by Directive 2000/8/EC of 20 March 2000) ;

**Provisions concerning coaches:**

- Directive 2001/85/EC of 20 November 2001, on the special provisions for vehicles intended for the transport of passengers and comprising, in addition to the driver's seat, more than eight seats(amended by Directive 2006/96/EC of 20 November 2006);
- Directive 95/28/EC of 24 October 1995 on the burning behaviour of materials used in the interior fittings of certain categories of motor vehicles.

For the EC type approval of new vehicles, Regulation 661/2009 also made the provisions of certain UNECE regulations mandatory, and in particular with regard to the areas analysed in this report, the following regulations:

**Provisions concerning all motor vehicles:**

- UNECE Regulation No. 34 on uniform provisions for the approval of vehicles concerning the prevention of fire hazards;

**Provisions concerning coaches** (vehicles of international categories M2 or M3):

- UNECE regulation no. 107 on uniform requirements for type approval of vehicles of categories M2 and M3 (*vehicles for the carriage of passengers and comprising, in addition to the driver's seat, more than eight seats*) as regards their general construction characteristics;

- UNECE regulation No. 118 on the uniform technical requirements concerning the burning behaviour and/or the capability to repel fuel or lubricant of materials used in the interior fitting of certain categories of motor vehicles.

Any manufacturer wishing to register a new vehicle in one of the countries of the European Union must have previously obtained type-approval at European level, according to Directive 2007/46, which implies compliance in particular with the UNECE Regulations referred to above. Individual or small-scale national type approval according to the decree of 4 May 2009 is also possible but the applicable rules are identical for the above-mentioned areas.

### **3.7.1 - Tanks and auxiliary liquid fuel tanks**

The corresponding requirements are contained in UNECE Regulation No. 34 on uniform provisions for the approval of vehicles concerning the prevention of fire hazards.

These requirements were also specified in Directive 70/221/EC of 20 March 1970, which has been recently repealed.

These requirements state that fuel tanks shall be mounted in a way that it is protected from the effects of a frontal collision, lateral collision or a collision occurring at the rear part of the vehicle.

For the purpose of their approval, as regards the prevention of fire risks in the event of a collision, M3 category vehicles (passenger vehicle with more than 8 seats in addition to the driver's seat and a maximum weight exceeding 5 tonnes) may, at the manufacturer's request, be subjected to a frontal collision test against a barrier, with an impact speed of around 50 km/h.

At the end of the test, the tanks should not leak. Only slight leakage of liquid in the fuel installation during the collision is permitted.

### **3.7.2 - Prevention of fire risks in coaches**

In the current regulations, irrespective of the specific provisions concerning the insulation of potential sources of fire in a coach, the risk of fire for this type of vehicle is dealt with in UNECE regulation no. 118 on uniform technical requirements concerning the burning behaviour and/or the capability to repel fuel or lubricant of materials used in the interior construction of certain categories of motor vehicles.

The risk of fire was also dealt with in the recently repealed European Directive 95/28/EC of 24 October 1995.

The materials used in the construction of the coach's inside bodywork must satisfy a number of requirements, the main one being that they should not exceed a combustion rate of 100 millimetres per minute under the test conditions described.

On the other hand, the regulations do not specify any toxicity requirements for fumes from combustion of these materials.

### **3.7.3 - Design of coach exits**

The corresponding requirements are contained in § 7.6 of Annex 3 of UNECE regulation no. 107 on uniform provisions for the approval of vehicles of categories M2 and M3, with regard to their general construction characteristics.

For vehicles designed exclusively for the carriage of seated passengers, the minimum number of doors to be fitted to the vehicle shall be two: either two service doors, or one service door and one emergency door. 0% of service doors must be located on the side corresponding to the traffic direction in the country where the vehicle is to be licensed. At least one service door must be located in the front half of the vehicle.

In addition, every public transport vehicle must have a minimum number of exits, consisting of the doors described above and emergency windows (all the escape hatches also count as an emergency exit). This minimum number of exits depends on the number of seats in the vehicle.

### **3.7.4 - Interior lighting and emergency lighting for coaches**

The bus, commissioned in January 2011, was not equipped with emergency lighting.

Its type had been approved in France in accordance with the provisions of the ministerial decree of 2 July 1982 on public transport. It should be noted that this decree, which prescribes, in particular, the rules relating to the construction, fitting-out, equipment and maintenance of vehicles, does not lay down any obligation relating to the installation of emergency lighting.

The coach involved in the accident had obtained a certificate of conformity for its type. It was therefore in conformity with the French regulations.

For coaches which have been put into service since then, the corresponding requirements concerning interior lighting are contained in § 7.8 of Annex 3 of UNECE regulation no. 107 on uniform provisions for the approval of vehicles of categories M2 and M3, with regard to their general construction characteristics.

Appropriate interior lighting shall be provided to illuminate stairways, steps, access to exits and their immediate surroundings, internal controls of all exits, and all areas with obstacles.. The vehicle shall be equipped with two interior lighting systems so that the failure of one system does not affect the other systems.

The regulation also specifies that vehicles of classes II, III and B must be equipped with an emergency lighting system that can be switched on by the driver when he/she is sitting in his/her seat. In addition, the operation of the emergency control of any service or emergency door must turn on the emergency lighting system. This new requirement has been incorporated into a recent amendment to UNECE Regulation No. 107.

This system must be able to remain on for at least 30 minutes and its power supply must be designed in such a way so as to minimise the risk of compromising its operation after an accident.

All units that provide emergency lighting must produce white light. The Regulation does not specify their location in the passenger compartment of the vehicle but specifies a minimum illumination level of 10 lux at a height of 75 cm above the aisles and 1 lux at the floor level, as well as rules regarding uniformity of illumination.

### **3.8 - Emergency evacuation procedure**

There is no text on the arrangements for the emergency evacuation of passengers.

There is no provision for passenger information (other than the writing on emergency exits) or specific training for the driver within the training to receive a driving licence or within the mandatory minimum initial training (FIMO).

However, the manuals for use by trainers give some instructions for rapid evacuation under normal conditions (if the coach is not overturned): immediate evacuation at the driver's request in the event of a fire and passengers' exit rank according to their position in the coach.

In response to a recommendation from the BEA-TT, in 2016, the French National Federation of Passenger Transport (FNTV) developed a brochure to raise awareness of the safety of passengers in coaches, which outlines the safety rules to be observed on board a coach and the instructions for evacuation in case of an emergency<sup>20</sup>. This document is intended to be made available to each passenger in front of his/her seat. However, it would be useful if it were supplemented by a description of the procedure to be followed in the event of a fire in the passenger compartment of the coach.

### **3.9 - Similar accidents**

#### **Coach fire that took place on 23 February 2008 on the A43 motorway near the village of Les Marches in Savoie**

The BEA-TT conducted an investigation into a coach fire on 23 February 2008 on the A43 motorway near the village of Les Marches in Savoie, which fortunately did not cause any casualties.

It involved a 91-seater double-decker coach carrying 52 people, which was completely destroyed by the fire.

The investigations carried out showed that the fire was the consequence of the disconnection between the coach's heating system boiler and its exhaust pipe which occurred during a collision that same morning and was not detected.

In its report published in June 2009, the BEA-TT had identified three aggravating factors:

- the absence of an automatic fire detection system;
- the vulnerability of coaches to fire (flammability of materials, general layout);
- the presence of only one staircase to evacuate the upper floor.

The BEA-TT made a number of recommendations regarding automatic fire detection and extinguishing systems in public passenger transport vehicles, the fire resistance of materials used in vehicle construction and evacuating the upper level of double-decker coaches.

In particular, the BEA-TT recommended to the DSCR to support, in the context of the revision of UNECE regulation no. 118, the project to strengthen the requirements concerning the burning behavior of materials used in vehicle construction.

The main changes to this regulation should particularly include:

- the maximum burning rate of materials should be lowered from 100 to 75 millimetres per minute;
- the requirement for combustion tests to take into account the vertical combustion velocity as a replacement for the horizontal combustion rate for all materials installed in the vehicle in a position other than horizontal.

---

<sup>20</sup> The brochure prepared by the FNTV is attached as Appendix 10 to this report

A joint proposal by France and Germany, to which Norway and Sweden joined, incorporating the two above developments, was presented at the October 2009 session of the Working Party on General Safety Provisions (GRSG)<sup>21</sup>.

UNECE regulation no. 118 was amended in 2013. The amended regulation specifies two separate tests depending on the horizontal or vertical position of the materials installed in the interior compartment of the vehicle, but does not lower the maximum combustion speed from 100 to 75 millimetres per minute. It should also be noted that other changes have also been introduced to integrate the electrical cables and various impregnability tests of the materials present in the engine compartment.

### **Accident on 31 July 1982 on the A6 near Beaune**

It is also worth mentioning the accident that occurred on 31 July 1982 on the A6 motorway in the village of Merceuil in Côte-d'Or, which resulted in the death of 53 people, including 44 children and adolescents, most of whom were on board a coach that caught fire following the accident.

This coach was travelling in convoy with a second coach. Both coaches had left the town of Crépy-en-Valois, about sixty kilometres north of Paris, the evening before, to take young people and their instructors to a summer camp in Aussois, Savoie. The convoy had taken the A6 motorway towards Lyon.

Near Beaune, during a slowdown on a section of highway where three lanes merged into two, a pileup involving a dozen vehicles including the two aforementioned coaches occurred.

During the pile-up, the tank of a light vehicle broke and spread its contents on the road. The spilled fuel ignited. Seven of the ten vehicles involved caught on fire.

The first coach that caught on fire from the rear could be completely evacuated through its front right door.

The second coach caught fire from the front. The right front door was blocked by a light vehicle that had crushed against it, so evacuation could only be done through the rear right door after being opened by the driver.

Fifteen out of 59 young people and one instructor out of five adults managed to get out of the vehicle before the smoke from the fire made the evacuation impossible, within a timeframe estimated by the Commission of Inquiry set up by the Minister of Transport of about 2 minutes.

The Commission considered that there were various risk factors that could have occurred over the course of the accident, and it was not possible to weigh them and prove that one or another of them had a more decisive effect than others in the sequence of events.

The Commission made 66 proposals divided into 8 themes:

- infrastructure and signing;
- the supervision and control of traffic, the organisation of emergency exits;
- the traffic;
- the vehicles;

---

<sup>21</sup> The Working Party on General Safety Provisions (GRSG) is the subsidiary body of the World Forum for Harmonization of Vehicle Regulations (WP.29), which prepares general safety regulatory proposals in WP.29. This group of experts conducts research and analysis to develop general safety requirements for vehicles, particularly buses and coaches.



- the people;
- controls and penalties;
- the organisation of long-distance transport for children;
- mobilisation, information.

In particular, the Committee proposed the following measures:

#### Concerning the protection of coaches against fire

- that the standards applied by builders and manufacturers for the fire resistance of materials used in the interior fittings of vehicles and seat upholstery are verified (limitation of the combustion rate measured according to the ISO 37 95 standard) and that stricter standards are, where appropriate, laid down by regulation;
- that studies are conducted on the possible toxicity of chemical compounds released by the rapid combustion of these materials when subjected to a fuel fire;
- that full-scale experiments be carried out to determine, under real conditions, how long it takes to evacuate a coach and the speed of propagation of an internal fire started by a gasoline fire.

#### Concerning emergency exits

- check that the European emergency exit regulations allow for a sufficiently rapid evacuation through the doors, in particular by testing the possible obstruction of their access by seats that are retractable or removable to some extent;
- that the conditions for manoeuvring and opening the emergency exits are brought to the attention of adult travellers and children's escorts;
- that the operating mechanism of the doors be re-examined in light of, in particular, the constraints in normal operating conditions, inadvertent openings and emergency evacuation.

The main regulatory measures taken following the accident included:

- a reduction in the maximum speed permitted for coaches;
- a reduction of the maximum speed permitted for all vehicles in rainy weather;
- the prohibition of the collective transportation of children during the peak summer travel period;
- the installation of an inviolable speed limitation device on heavy-goods vehicles and coaches.

## **4 - Analysis of the course of the accident and rescue operations**

### **4.1 - The route of the vehicles before the accident**

#### **4.1.1 - *The route of the articulated lorry***

On 23 October 2015, the day of the accident, the driver of the articulated lorry began his day around 5.30 a.m. After spending the night in the cab of his articulated lorry with his young son, which was parked in the car park of a restaurant in Coutras in Gironde (33), he went to the premises of a company in Saint -Michel-de-Montaigne in Dordogne (24) in order to deliver a load of lumber. He arrived in Saint-Michel-de-Montaigne around 6.00 a.m. and left around 7:00 a.m. after unloading his cargo.

After crossing the town of Castillon-la-Bataille, he continued his route by taking the RD 17 towards Puisseguin.

#### **4.1.2 - *The route of the coach***

On 23 October 2015, the day of the accident, the coach driver went on duty around 6.15 a.m. He picked up his vehicle which had been parked since Wednesday, 22 October around 7 p.m. in a car park near the town hall of Génissac in the Gironde department (33). He then went to Petit-Palais to take on his passengers, who he had to take to Arzacq-Arraziguet in the department of Pyrénées-Atlantiques (64), as part of an excursion organised by the senior clubs of the villages of Petit-Palais-et-Cornemps and Saint-Sauveur-de-Puynormand.

He arrived at Petit-Palais around 7 a.m. AT 7.15 a.m., after 48 passengers had boarded, he continued his route to Arzacq-Arraziguet. After crossing the town of Puisseguin, he continued his route by taking the RD 17 motorway towards Castillon-la-Bataille.

It was dark and although it was not raining, the road was wet as it travels through a forested area.

### **4.2 - The collision and the ignition of the fire**

The articulated lorry left its course as it approached a tight right-hand bend with a radius of about 55 m at a speed estimated by the simulation of about 75 km/h.

The technical appraisals carried out on the road as a whole did not reveal any failure of the vehicle which could have been the cause of this departure from the trajectory.

The reasons for which the articulated lorry thus swerved are therefore very probably related to a speed which is unsuitable for traffic conditions and the geometry of the road.

During the operation of the articulated lorry's braking system, the defects observed on the braking system of its semi-trailer could also have led to or favoured its jack-knife.

The coach driver, approaching the same bend at an estimated speed of 45 km/h, saw the articulated lorry that was driving towards him in his lane.

He then braked and moved as far as possible to the right.

A few seconds after the collision, the sound of a flare was heard and flames appeared in front of the coach's windscreen between the two vehicles.

## **4.3 - Evacuating the coach**

After exiting his partly crushed driver's cab, the driver of the coach opened the front door of his vehicle by operating the manual emergency opening system. He exited the bus through that door and headed for the central door which he opened in the same way from the outside.

The passenger who was sitting on the right-hand side of the window seat immediately behind the side door in the middle of the coach, was thrown down the stairs after the guardrail that was in front of her broke.

A passenger used an emergency hammer to break the window located at the side door in the middle of the bus that was not open and so the passengers could escape from the burning coach through the hole thus formed.

Apart from the driver of the coach, only one passenger was able to use the front door of the vehicle to escape.

Six other passengers were able to evacuate the bus through the central corridor and the side door before the fire and the toxic gases released made it impossible to evacuate.

### **4.3.1 - Notification of emergency services**

The alert was given at 7:30 a.m. by someone who had witnessed the accident and called Gironde department's fire and rescue call centre.

The first emergency fire truck belonging to the Castillon-la-Bataille rescue centre arrived at the scene of the accident around 7:50 a.m.

The firefighters carried out a massive fire attack by means of two water hoses and a foam hose and gathered the victims of the accident in the premises of the village hall in Puisseguin, which they transformed into an advanced medical post.

The victims with minor injuries were then transported to Libourne hospital, those with more serious injuries to the Bordeaux University Hospital.

The fire was reported as contained at 8.44 a.m.

### **4.3.2 - Assessment and location of victims**

A total of 43 fatalities, 41 bus passengers and the two occupants of the articulated lorry were recorded, and 8 were injured (4 with minor injuries and 4 seriously injured), including the driver and 7 coach passengers.

The body of the driver of the articulated lorry was found outside his driver's cab, between the articulated lorry and the coach, at the foot of the driver's door of the articulated lorry.

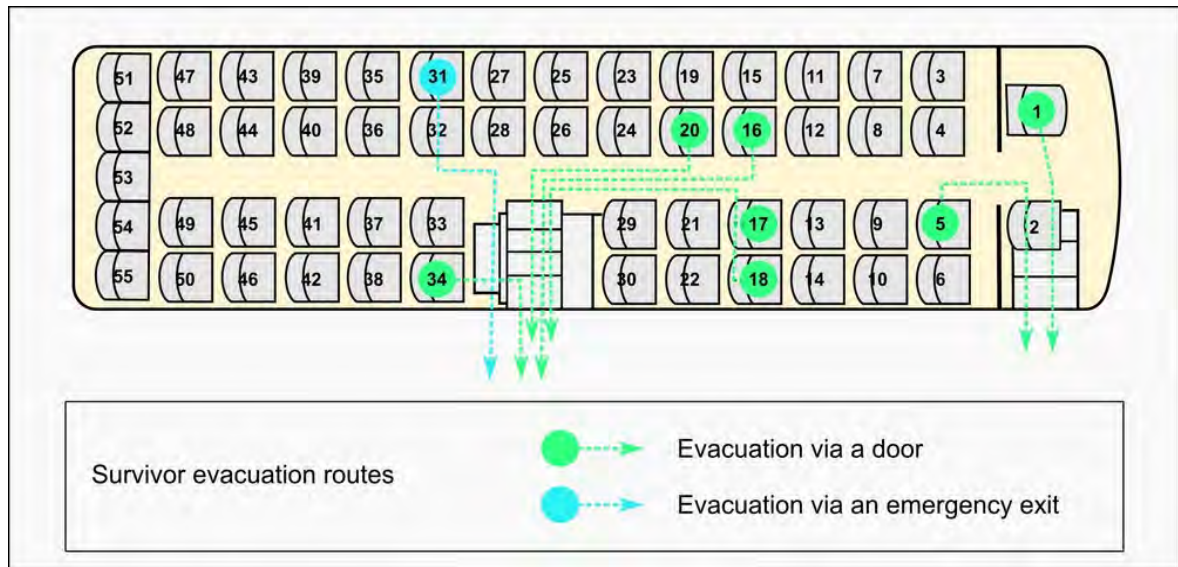
The body of the passenger in the articulated lorry was found in the driver's cab of the articulated lorry in the middle seat.

The bodies of some of the coach passengers were found sitting in their seats, but most were in the central aisle.

The location of the coach's 49 occupants at the time of the accident could not be accurately determined, as passenger statements about their location were sometimes contradictory.

These testimonials nevertheless allowed the BEA-TT investigators to determine the probable position of the occupants of the coach surviving the accident, as well as the route they followed for their evacuation.

The figure below presents the hypothesis used by the BEA-TT survey.



**Figure 84: Location of surviving coach occupants and the evacuation route followed**

#### **4.3.3 - Assessment of the means of assistance implemented**

For this accident, significant means were mobilised and dispatched to the site. In particular, the following were present at the site of the accident:

- personnel and vehicles from the Gironde departmental fire and rescue service, emergency services doctors from the Libourne (33) and Bordeaux (33) hospitals, doctors, psychologists and victim support associations;
- gendarmes from the Libourne company, the Gironde departmental gendarmerie, the research section of Bordeaux-Boulliac, the criminal research institute of the National Gendarmerie in Pontoise, and the mobile gendarmerie forces;
- the aerial department of the National Gendarmerie of Bordeaux-Mérignac (33) and the Air Transport Gendarmerie.

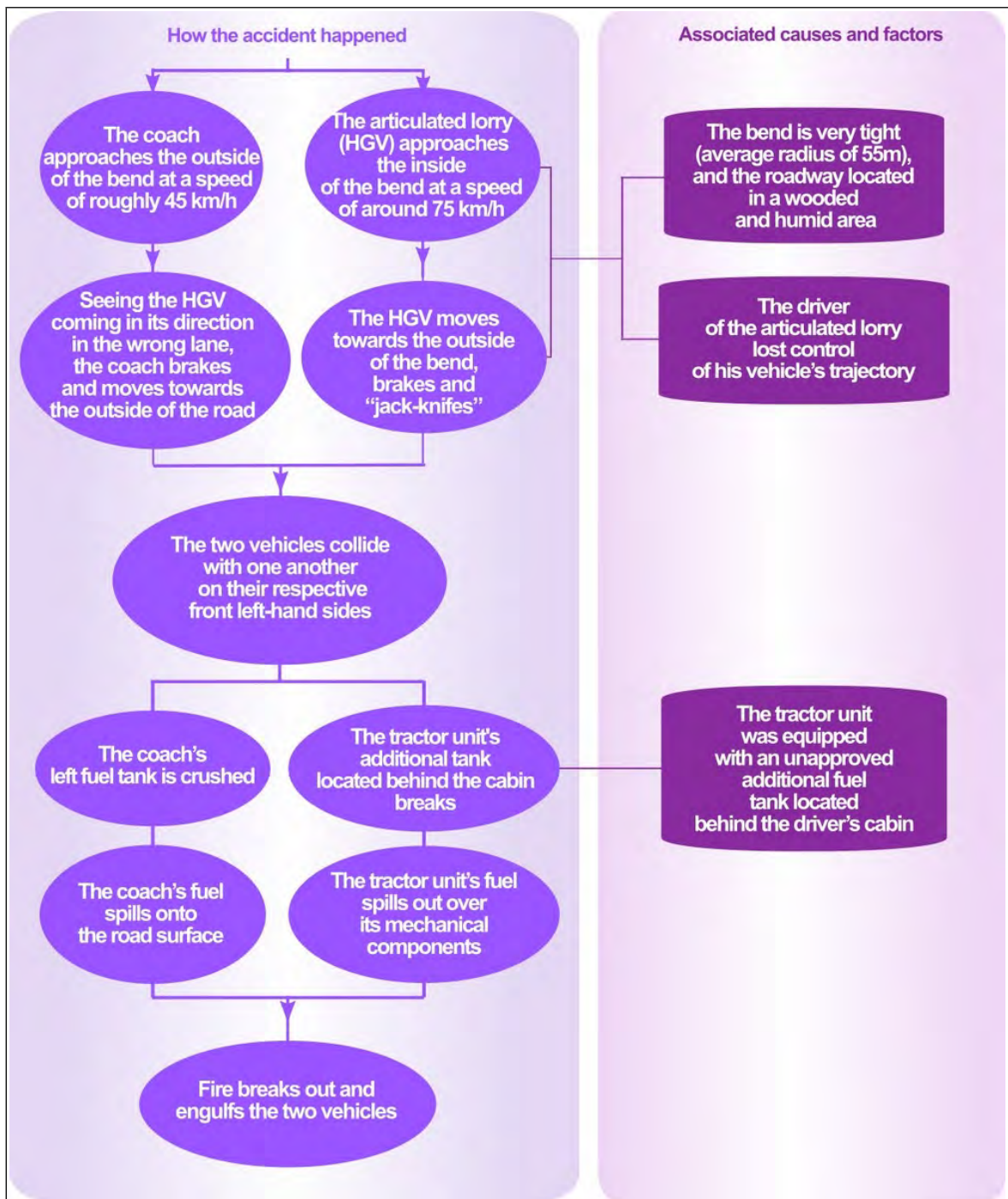
A crisis centre was opened in the Gironde prefecture and a toll-free number was made available to the families of the victims.



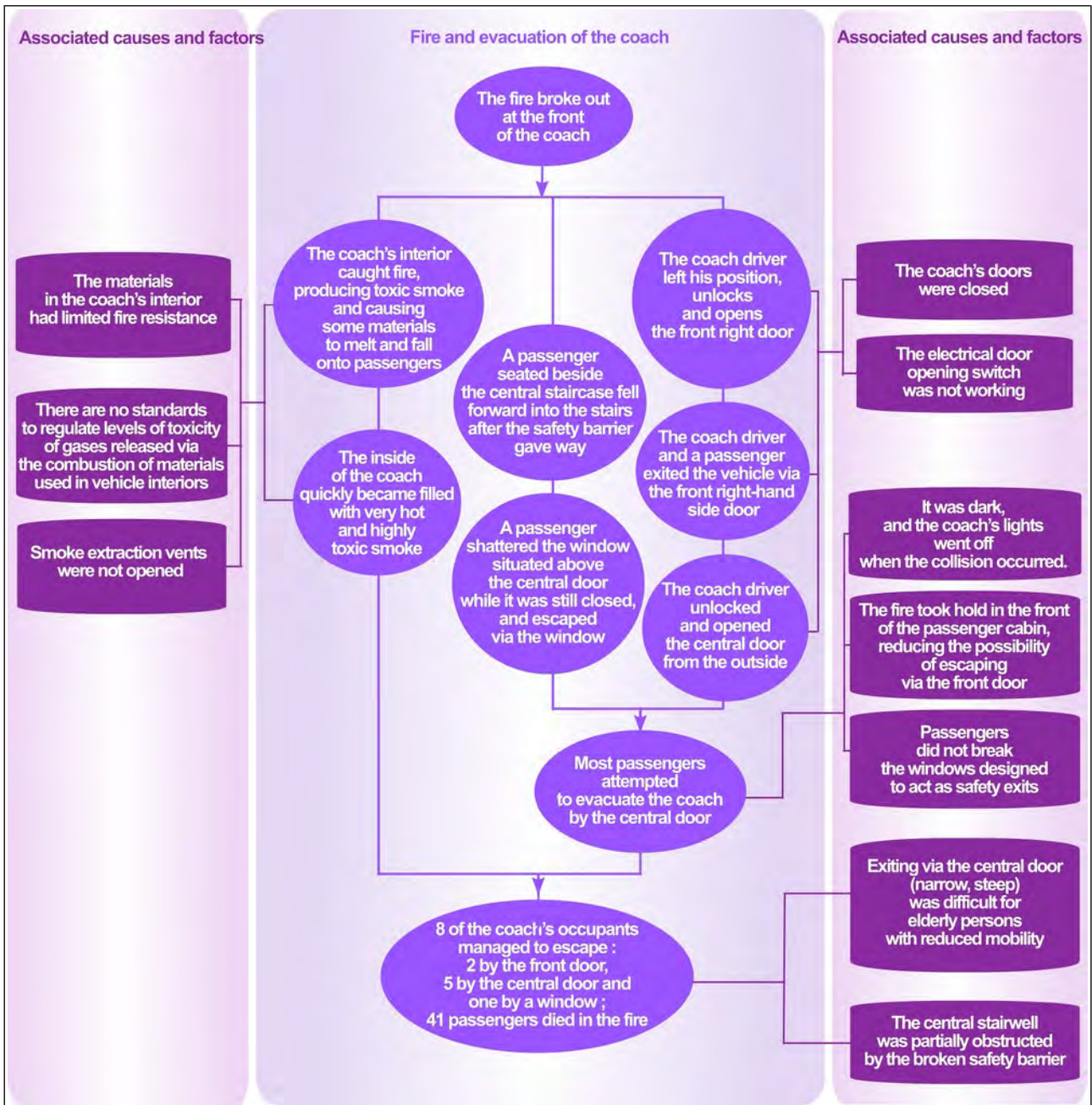
## 5 - Analysis of causes and associated factors, preventive guidelines

### 5.1 - The pattern of causes and associated factors

The investigations carried out by the BEA-TT made it possible to establish the following two graphs, which summarise the course of the accident and identify the causes and associated factors.



**Figure 85: Diagram of causes and associated factors  
Vehicle collision and conflagration**



**Figure 86: Diagram of causes and associated factors  
Fire and evacuation of the coach**

This analysis led the BEA-TT to seek preventive recommendations in the following 4 domains:

- the signs for the bend;
- the additional fuel tanks;
- the burning behaviour of coaches;
- the smoke extraction and evacuation of coaches.

## **5.2 - The signing for the bend**

### **5.2.1 - *Reminder of the findings***

This right-hand bend is on a gentle incline, in the articulated lorry's direction of traffic. It has an average radius of about 55 m to the right. It is preceded by a tight left-hand bend.

Moreover, the slope bordering the inside of the bend masks a large part, which reduces the readability of the bend and the visibility of vehicles travelling in the opposite direction.

Given its geometrical characteristics, BEA-TT investigators consider that it cannot be safely crossed by a light vehicle at a speed greater than 50 km/h. This speed can also be achieved by applying the method outlined in the SETRA Practice Guide of July 2002 entitled "How to Signpost Bends".

This 6-m wide bend presents particular difficulties for heavy-duty vehicles, which cannot easily cross it. The road inside the bend does not have a drivable or other hard shoulder, but has an A2 type border (15X20X100 cm) and a ditch. The bend must therefore be approached at a substantially lower speed.

In the traffic direction of the road, upstream of the area of the accident, the road exhibits defects in wheel rutting and wear of the lining at the passage points of vehicle wheels.

Since the tachograph of the articulated lorry was destroyed during the accident, it is not possible to know the articulated lorry's exact speed when it was approaching the last bend immediately before the accident.

The kinematic reconstruction carried out by the judicial expert shows that the articulated lorry approached this bend at a speed estimated at about 75 km/h.

It should be emphasised that this is only an estimate of the articulated lorry's actual speed, but these findings, however, suggest that the articulated lorry probably approached this bend at an inappropriate speed, leading to the loss of control of the vehicle.

### **5.2.2 - *Analysis***

Although no accidents have been recorded at this bend over the past 5 years, its examination shows that it presents particular difficulties for vehicles using this route:

- its radius is tight and appreciably lower than that of the bend preceding it;
- there is a slope bordering the inside of the bend which reduces its readability and the visibility of vehicles travelling in the opposite direction;
- its 6-m wide road surface does not have any extra width at the bend, which makes it difficult for heavy-duty vehicles to cross.

The reasons why the articulated lorry did not approach the bend at a more moderate speed are unknown, whether it was a result of carelessness, a distraction or misjudgment of the characteristics of the bend.

Nevertheless, it seems advisable that there should be vertical road signing at the approach of the bend in order to alert drivers who are not familiar with the road of the difficulty of the bend.

The application of the SETRA practical guide of July 2002 relating to the vertical road signposting of bends results in this bend being referenced as a class C bend and having a

signaling recommendation with an “A1” sign, “J1” type road traffic markers and a “J4” type multichevron<sup>22</sup> road traffic marker.

At the time of the accident, the bend was signaled by an “A1d” sign ahead of the bend, in the driving direction of the articulated lorry and by “J1” road traffic markers placed on the shoulder, but there was no “J4” road traffic marker. However, it should be noted that since the accident, the road manager has placed “J4” multichevron road traffic markers outside the bend in each direction of traffic.

The BEA-TT notes that the road manager reinforced the vertical signing of this bend.

*Nevertheless, in view of the above findings and analysis, without making a formal recommendation, the BEA-TT invites the road manager to consider the advisability of limiting the maximum authorised speed to 50 km/h at this bend.*

## **5.3 - Additional fuel tanks**

### **5.3.1 - Reminder of the findings**

Given the condition of the wrecks after the fire, it was not possible to determine with certainty the scenario leading to the outbreak of the fire. It appears, however, that the additional tank of the tractor unit which was installed on the back of the driver's cab above mechanical elements such as the exhaust line and the selective catalytic reduction device which are heated to a high temperature during operation, and which broke upon impact, played a major role in triggering this fire.

It should be emphasised that this installation was not foreseen by the tractor unit's manufacturer.

It should also be pointed out that the tractor unit had passed a technical inspection on 24 August 2015, after the installation of the additional tank, without this inspection mentioning the presence of the tank.

### **5.3.2 - Analysis**

It is worth mentioning that the installation of an additional fuel tank is not a significant transformation within the meaning of Article R. 321-16 of the Highway Code and defined in Article 13 of the decree of 19 July 1954 on the type-approval of motor vehicles.

As such, a new approval of the modified vehicle is not required to ensure compliance with the statutory instruments.

For the same reason, the legality of the installation of an additional tank shall not be verified during a technical inspection, the purpose of which is to verify the good working condition and the satisfactory state of maintenance of the systems.

On the other hand, any modification of the vehicle considered as a significant transformation requiring an individual technical type approval, such as modification of the authorised gross vehicle weight (PTRV), the braking system or the length (excluding the non-conformance of the energy with the identification document) is subject to examination during the technical inspection with the obligation of counter-inspection in the event of failure.

It seems desirable that this type of non-conformity (installation of an unlicensed tank) be detected during the technical inspections so that the owners of the concerned vehicles can effectively correct the defects found.

---

<sup>22</sup> “J4” road traffic marker: square or rectangular road traffic marker with one or more white chevrons on a blue background to complete the J1 road traffic markers when reinforcement of the alert is necessary



To do so, it is necessary that the regulations be amended so that the addition of any fuel tank of a significant capacity not expressly foreseen by the manufacturer of the vehicle is considered as a significant transformation and that the technical instructions relating to vehicle inspection are updated accordingly.

This change will lead, on the one hand, to the obligation of an individual technical type approval of the vehicle after transformation and, on the other hand, will allow any non-conformities to be detected during the vehicle's technical inspections in order to ensure that the owners of the concerned vehicles take the necessary steps to correct the defects found.

Accordingly, the BEA-TT makes the following recommendation:

**Recommendation R 1 (Directorate General for Energy and Climate - DGEC):**

**Amend Article 13 of the decree of 19 July 1954 relating to the type-approval of motor vehicles in order to add to the list of significant conversions any addition of a fuel tank of significant capacity not expressly foreseen by the manufacturer of the motor vehicle and update the technical instructions for vehicle inspection accordingly.**

*In view of these elements and without making any formal recommendation, the BEA-TT invites road haulier associations to make their members aware of the need to install tanks on their vehicles in compliance with the technical rules for approval.*

## **5.4 - The burning behaviour of coaches**

### **5.4.1 - Reminder of the findings**

After the collision between the coach and the articulated lorry, the bus's compartment was quickly invaded by toxic fumes and then attacked by flames. The vehicle then completely burned very quickly, which did not allow the coach passengers time to evacuate the vehicle.

### **5.4.2 - Analysis**

Measures should therefore be taken to improve the fire-resistance of buses in such a way as to delay as much as possible the complete burning of the coach and to reduce the toxicity of the fumes emitted by the combustion of the materials used to construct it.

Regardless of the insulation of potential fire sources, the burning behaviour of a coach depends mainly on the materials used in its.

The constituent materials of the passenger compartment must comply with certain fire-resistance tests, relating to their flammability and the speed of propagation of the flames, in accordance with UNECE regulation no. 118.

These materials should not catch fire due to a low energy source (flame from a cigarette lighter or cigarette butt), but they are still flammable; some are even highly flammable when attacked by devouring flames and can even release highly toxic gases.

Other requirements of the UNECE regulation no. 118 concern the melting behaviour of materials. The procedure of these tests is based on the use of an electric radiator with a working power of 500 W, the sample to be tested being positioned 30 mm below the radiator for at least 5 m in. However, such requirements do not allow for the materials to withstand high temperatures, such as those encountered in this accident. The testimony of passenger P4 also confirms this.

It should also be noted that the regulations do not specify any toxicity requirements for fumes from the combustion of these materials.

Indeed, the synthetic materials that make up the vast majority of the components of a coach are organic polymers (plastics, polyurethane foam, synthetic resins, etc.). Like all organic products, they are inherently good to very good fuels and some are highly flammable (polyurethane foam seat padding for example) when the relative amounts of heat and oxygen necessary for their combustion are reached.

To slow down their vulnerability to combustion and flame propagation, chemicals may be added to these materials, but such additives only reduce their burning rate for a small fire zone.

In summary, when large quantities of materials that are combustible to some extent, even if flame retardants are added to them, are used in the manufacture of a vehicle, they irrevocably contribute to the propagation and supply of fire as soon as the fire reaches a certain level magnitude.

In addition, the gases released by the combustion of these materials mainly consist of CO (carbon monoxide), CO<sub>2</sub> (carbon dioxide), HCN (hydrogen cyanide), NH<sub>3</sub> (ammonia) and HCL (hydrogen chloride), which are all very toxic.

However, they are not subject to legislative control, which is not the case for other modes of transport, in particular air and rail.

Figure 88 below, taken from a 2014 publication by the German Federal Road Research Institute (BAST) on smoke production, its development and its toxicity in bus fires, summarises the main fire tests of interior materials for different modes of transport.

Overview about the fire tests for interior materials in different transport means				
	Buses [ECE R 118]	Rail vehicles [EN 45545-2]	Ships [SOLAS Chapter II-2]	Aircrafts [FAR/JAR/CS 25.853]
Horizontal burning rate	ISO 3795 (horizontal mounted components)	No test	No test	FAR/JAR/CS 25.853 b(5) (cabin and cargo compartment)
Vertical burning rate	ISO 3795 (vertical mounted components)	EN ISO 11925-2 (Filter materials)	ISO 6940/41 (drapes and hangings)	FAR/JAR/CS 25.853 b(4) (cabin and cargo compartment)
Heat release rate	No test	ISO 5660-1 (most materials)	ISO 5660-1 (fire-restricting materials in high speed crafts)	FAR/JAR/CS 25.853(d) (cabin compartment)
Smoke density	No test	ISO 5659-2 (most materials)	ISO 5659-2 (most materials)	FAR/JAR/CS 25.853 (d) (cabin compartment)
Smoke gas toxicity	No test	ISO 5659-2 (most materials)	ISO 5659-2 (most materials)	BSS 7239/ABD 0031 (cabin compartment)
Calorimeter test for seats	No test	ISO 9705-2 (passenger seats)	ISO 8191-1/-2 (upholstered furniture)	FAR/JAR/CS 25.853(c) (upholster furniture)

(BAST document)

**Figure 87: Overview of fire testing for interior materials in various modes of transport**

It can be seen that for coaches, only the horizontal and vertical displacement speeds of a flame are subject to requirements under ISO 3795, as required by UNECE regulation no. 118.

On the other hand, there is no requirement for the amount and speed of heat produced, the density of the fumes released, the toxicity of the fumes, unlike the other three modes of transport involving trains, boats and planes.

The regulations concerning coaches should therefore be more demanding as regards the nature and performance of the materials used for fire resistance and the toxicity of the gases emitted by their combustion for passenger vehicles.

Accordingly, the BEA-TT makes the following recommendation:

**Recommendation R 2 (Directorate General for Energy and Climate - DGEC):**

**Within the framework of the revision of UNECE regulation no. 118, it has been proposed that the requirements concerning the fire resistance of materials used in the construction of vehicles be strengthened and that new requirements regarding the toxicity of the gases released by the combustion of these materials be introduced.**

## **5.5 - The smoke extraction and evacuation of coaches**

### **5.5.1 - *Reminder of the findings***

It was dark, the coach lights went out upon collision, the coach was quickly overrun with opaque fumes. It is therefore very likely that most passengers were severely disoriented and were unable to use the smoke extraction and emergency evacuation devices fitted to the vehicle.

Moreover, the observations made and the testimonies of the survivors show that the coach corridor as well as the staircase leading to the central side door very quickly became congested and that the coach was very quickly invaded by toxic fumes. Most of the victims lost consciousness quickly.

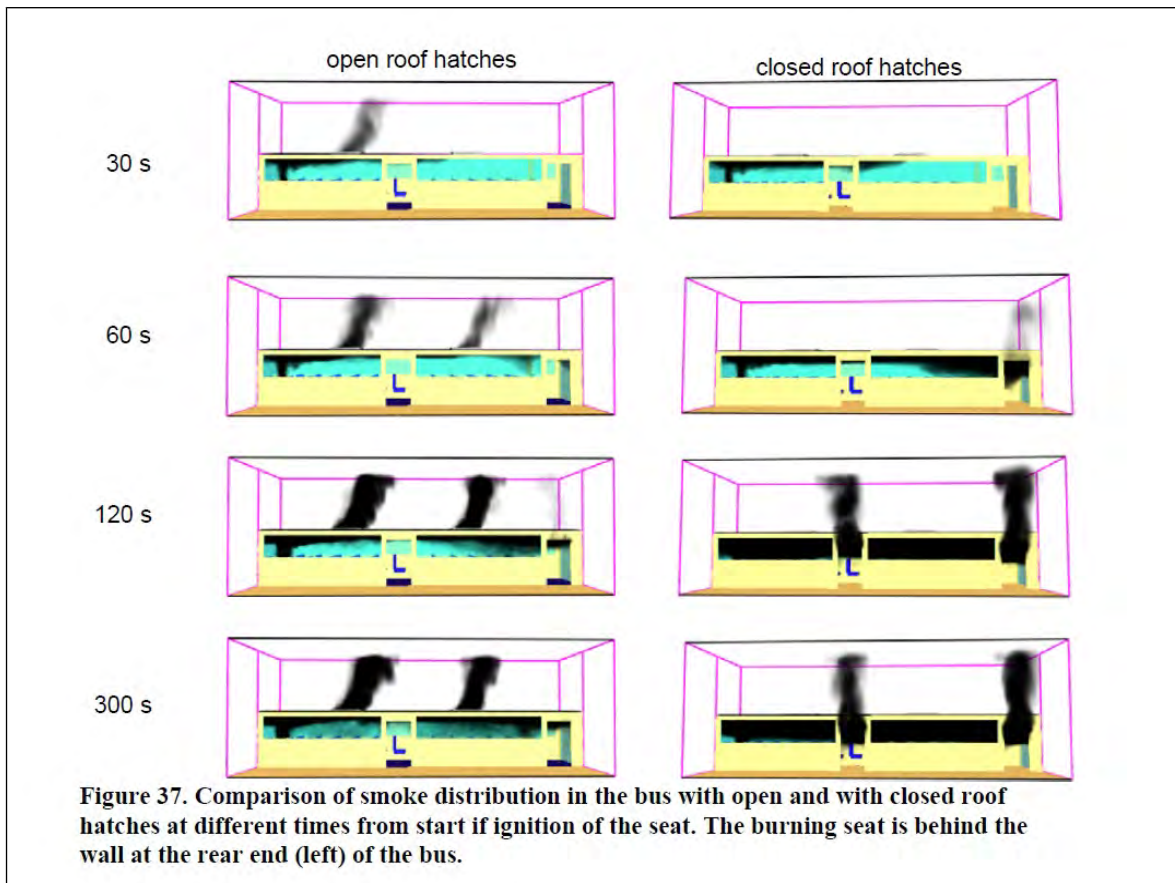
The findings and the testimonies of the survivors also show that the smoke evacuation devices fitted to the bus, namely the roof hatches, were not activated.

### **5.5.2 - *Analysis***

Simulations carried out by the German Institute BAST and the Swedish SP Technical Research Institute have shown that in a fire, the passenger compartment of the coach is very quickly invaded by the generally very toxic fumes, which in fact limits the passengers' evacuation possibilities, especially when they have difficulty moving as a result of their age.

These simulations showed that, during a fire, the smoke spreads in the upper part of the passenger compartment, then destratifies and falls again. The simulations also demonstrated the value of the smoke extraction system, which significantly delayed the vehicle becoming completely flooded with smoke and gave passengers valuable seconds to evacuate the vehicle.

Figure 88 below, taken from a 2008 study by the Swedish institute, illustrates the kinematics of a smoke invasion of the passenger compartment of a coach simulating a fire to a passenger seat located at the rear of the bus according to whether the roof hatches are open or closed.



(document SP Technical Research Institute of Sweden)

**Figure 88: Comparison of the propagation of smoke in the passenger compartment of a coach, with open doors, during a fire which started at a passenger seat located at the rear depending on whether or not the roof hatches were open**

The images on the left show the effectiveness of the smoke extraction hatches when they are opened, preventing the complete invasion of the passenger compartment by the fumes by five minutes (300 s).

Conversely, the images on the right show that between one to two minutes (60 to 120 s) after the start of the fire, the smoke has completely invaded the passenger compartment, despite the opening the front and central access doors at the outset of the fire. It should be noted that there is a rapid destratification of the fumes (within 60 s) away from the source of the fire and that the opening the coach doors does not delay the invasion of the fire. This is why the roof hatches, which must be opened rapidly from the start of the fire, are of great use.

One of the causes of the high death toll of this accident was that it was very difficult for passengers to quickly evacuate the vehicle and get away from the toxic fumes which quickly spread in the passenger compartment.

This situation was in particular the result of the passengers' misunderstanding of the location of the smoke extraction devices and their opening mechanism. The passengers' vision was obscured by the thickness of the smoke and the lack of lighting. The passengers' ignorance of the emergency evacuation procedures of the vehicle also played a role.

It should be noted that the coach driver was not seriously injured during the accident, which enabled him to open the doors manually using the existing emergency system and provide assistance to the passengers. The number of casualties would have been greater



had the driver been seriously injured or trapped in his seat as a result of deformations in the structure of the coach.

It is difficult to estimate how long it took the driver to open the two access doors which allowed the passengers to evacuate, but it is clear that the survival time inside the passenger compartment in such a fire is extremely short. It is therefore essential to react appropriately as soon as the fire starts.

It is therefore important that passengers are aware of what they must do in an emergency and that they know where a certain number of switches and equipment are located (location of emergency exits, emergency hammers to break windows, and so on).

It is therefore necessary that better information for coach passengers should be provided before any journey.

The BEA-TT has already had the opportunity to make a recommendation for the dissemination of information to passengers on the use of smoke evacuation devices and emergency evacuation procedures for coaches. The analysis of the present accident merely confirms its desirability.

In 2016, the French National Federation of Passenger Transport (FNTV) developed a brochure to raise awareness of the safety of passengers in coaches, which recalls the safety rules to be observed on board a coach and the instructions for evacuation in case of an emergency.

*The BEA-TT invites FNTV to supplement it by describing the procedure to be followed in the event of a fire in the passenger compartment of the coach.*

Measures should also be taken to permit rapid and automatic opening of smoke extraction devices so as to delay the invasion of the passenger compartment by toxic fumes to allow passengers more time to evacuate the vehicle.

Accordingly, the BEA-TT makes the following recommendation:

**Recommendation R 3 (Directorate General for Energy and Climate - DGEC):**

**Within the framework of the amendment of UNECE regulation no. 107, it is proposed that the requirements concerning the opening mechanisms of smoke extraction systems be strengthened in order to facilitate their opening.**

The regulations specify that all emergency windows must be able to be manoeuvred easily and instantaneously from inside and outside the vehicle. They also accept that the windows that are used as emergency exits are made of safety glass that is easy to break with a device placed in the immediate vicinity.

If the latter procedure seems acceptable in the event of the evacuation of a vehicle whose service doors are unusable as a result of an accident, the time taken to implement it does not seem compatible with the need to evacuate the vehicle in an emergency, in particular in the event of a fire spreading in the passenger compartment of the vehicle.

The findings also showed that most of the passengers in the rear of the bus were trapped by the fire and toxic fumes and found themselves stuck in the central aisle without being able to reach the central side door of the vehicle, which was the only exit that could be used given the extent of the fire at the front of the vehicle.

It is therefore desirable to facilitate an emergency evacuation:

- by proposing the addition of another exit located at the rear part of the vehicle that can easily be followed by all the coach passengers;
- and/or by imposing release systems only on emergency exit windows that can be manoeuvred instantly for ease of use.

This additional exit could be similar to the "parachute door" style emergency doors currently fitted to double-decker coaches. Failing that, an increase in size of one or two service doors and of their access so that it can be used by a wheelchair passenger or by two front passengers should at a minimum be imposed on all new coaches.

Accordingly, the BEA-TT makes the following recommendations:

**Recommendation R 4 (Directorate General for Energy and Climate - DGEC):**

**Within the framework of the revision of UNECE regulation no.107, it is proposed that:**

- **an emergency door positioned in the rear part of the vehicle be added. Failing this, extend the provisions of decree 2015-1170 of 22 September 2015 on the accessibility of rolling stock for regular intercity public road transport services for freely organised persons to all coaches.**
- **and/or reinforce the requirements for the opening mechanisms of emergency windows in order to make them manoeuvrable instantaneously to facilitate their use in the event of emergency evacuation**

It should be remembered that the coach was carrying 49 people. Although both vehicle accesses, the front door and the central door, seem to be sufficient in day-to-day operations, they do not appear to be adequate for an emergency evacuation.

The testimonies gathered show that after the collision, the coach lights went out and the passengers found themselves in the darkness. None of them mentioned the presence of evacuation marker lights allowing them to identify where they were in the coach, to locate emergency evacuation devices (window breaker hammers, emergency exits) and to proceed to the exits of the vehicle.

The coach, which had been approved in France in accordance with the provisions of the ministerial decree of 2 July 1982 on public transport, was not equipped with emergency lighting. It should be emphasised that even if the vehicle had been equipped with such lighting in accordance with the requirements of § 7.8 of Annex 3 to UNECE regulation no. 107 on the uniform provisions for the approval of category M2 and M3 vehicles with regard to their general construction characteristics, it is not certain that this illumination would have been sufficiently powerful to allow passengers to operate the emergency devices (smoke extraction hatches and emergency exits) and evacuate the vehicle in good conditions, given the presence of opaque smoke in the coach's passenger compartment.

It is therefore desirable that the regulations governing emergency lighting systems fitted to coaches be strengthened so that evacuation marker lights make it easier to use the emergency evacuation devices and that the passenger's visibility remains during the evacuation of the vehicle, especially if the passenger compartment becomes flooded with opaque fumes.

Accordingly, the BEA-TT makes the following recommendation:

**Recommendation R 5 (Directorate General for Energy and Climate - DGEC):**

**Strengthen the regulation of "emergency lighting systems" for coaches in order to ensure that the safety devices to be used for emergency evacuations and the vehicle's marker lights of the evacuation routes remain visible, especially if the passenger compartment becomes flooded with opaque fumes.**

## 6 - Conclusions and recommendations

### 6.1 - Causes of the accident

The direct cause of the accident was the loss of control of the articulated lorry, which was approaching a right-hand bend with an approximately 55 m radius, which led the lorry to swerve into the left-hand lane and to strike a coach that was travelling in its lane in the opposite direction.

A violent fire broke out immediately after the collision, as the coach was very quickly invaded by toxic black smoke and attacked by the flames.

Of the 49 occupants of the bus, only 8 were able to evacuate the vehicle.

Several factors played a role in the heavy toll of this accident:

- the presence of an additional diesel fuel tank installed on the back of the articulated lorry's driver cab, that was not in accordance with regulations;
- the nature of the materials used for the coach's interior fitting, their fire resistance and the toxicity of the gases emitted by their combustion;
- the difficulty the passengers faced in operating the smoke extraction devices fitted to the coach;
- the difficulty the passengers faced when they tried to use the coach's two access points and emergency exits;
- the lack of lighting inside the coach after the collision.

### 6.2 - Preventive guidelines

In light of these elements, the BEA-TT makes the following recommendations:

#### **Recommendation R 1 (Directorate General for Energy and Climate - DGEC):**

**Amend Article 13 of the decree of 19 July 1954 relating to the type-approval of motor vehicles in order to add to the list of significant conversions any addition of a tank of fuel of significant capacity not expressly foreseen by the manufacturer of the motor vehicle and update the technical instructions for vehicle inspection accordingly.**

#### **Recommendation R 2 (Directorate General for Energy and Climate - DGEC):**

**Within the framework of the revision of UNECE regulation no. 118, it has been proposed that the requirements concerning the fire resistance of materials used in the construction of vehicles be strengthened and that new requirements regarding the toxicity of the gases released by the combustion of these materials be introduced.**

#### **Recommendation R 3 (Directorate General for Energy and Climate - DGEC):**

**Within the framework of the amendment of UNECE regulation no. 107, it is proposed that the requirements concerning the opening mechanisms of smoke extraction systems be strengthened in order to facilitate their opening.**



**Recommendation R 4 (Directorate General for Energy and Climate - DGEC):**

**Within the framework of the revision of UNECE regulation no.107, it is proposed that:**

- **an emergency door positioned in the rear part of the vehicle be added. Failing this, extend the provisions of decree 2015-1170 of 22 September 2015 on the accessibility of rolling stock for regular intercity public road transport services for freely organised persons to all coaches.**
- **and/or reinforce the requirements for the opening mechanisms of emergency windows in order to make them manoeuvrable instantaneously to facilitate their use in the event of emergency evacuation.**

**Recommendation R 5 (Directorate General for Energy and Climate - DGEC):**

**Strengthen the regulation of "emergency lighting systems" for coaches in order to ensure that the safety devices to be used for emergency evacuations and the vehicle's marker lights of the evacuation routes remain visible, especially if the passenger compartment becomes flooded with opaque fumes.**

*Furthermore, without making a formal recommendation, the BEA-TT invites:*

- *the road manager to consider the advisability of limiting the maximum authorised speed to 50 km/h on this bend;*
- *road hauliers associations to make their members aware of the need to install tanks on their vehicles in compliance with the technical rules for approval.*
- *the FNTV to supplement its 2016 coach passenger safety awareness brochure, which outlines the safety rules to be complied with on a coach and the instructions for evacuation in case of emergency, giving a description of the procedure to be followed in the event of a fire in the coach's passenger compartment.*

# APPENDICES

Appendix 1: Decision to initiate an investigation

Appendix 2: Site plans

Appendix 3: Aerial view of RD 17 in the area of the accident

Appendix 4: Cross-sectional horizontal and vertical alignment of RD 17 at the accident site

Appendix 5: Accident frequency rate on the RD 17 between 2010 and 2015

Appendix 6: Description of the coach's heating and air conditioning systems

Appendix 7: Extract from the safety data sheet for refrigerant R134a

Appendix 8: Extract from the safety data sheet for Glysantin G48

Appendix 9: Excerpts from the "TOTAL Diesel Premier" fuel safety data sheet

Appendix 10: FNTV record



## Appendix 1: Decision to initiate an investigation



Liberté • Égalité • Fraternité  
REPUBLIQUE FRANÇAISE

MINISTÈRE DE L'ÉCOLOGIE, DU DÉVELOPPEMENT DURABLE  
ET DE L'ÉNERGIE



*Le Directeur*

La Défense, le 23 octobre 2015

### DECISION

Le directeur du bureau d'enquêtes sur les accidents de transport terrestre,

Vu le code des transports et notamment les articles L. 1621-1 à L. 1622-2 et R. 1621-1 à R. 1621-26 relatifs, en particulier, à l'enquête technique après un accident ou un incident de transport terrestre ;

Vu les circonstances de l'accident impliquant un autocar et un poids lourd survenu le 23 octobre 2015 à sur la route départementale n°17 à Puisseguin, dans le département de la Gironde ;

### décide

**Article 1 :** Une enquête technique est ouverte en application des articles L. 1621-1 et R. 1621-22 du code des transports concernant l'accident impliquant un autocar et un poids lourd survenu le 23 octobre 2015 sur la route départementale n° 17 à Puisseguin, dans le département de la Gironde,

Jean PANHALEUX



## Appendix 2: Plans of the scene

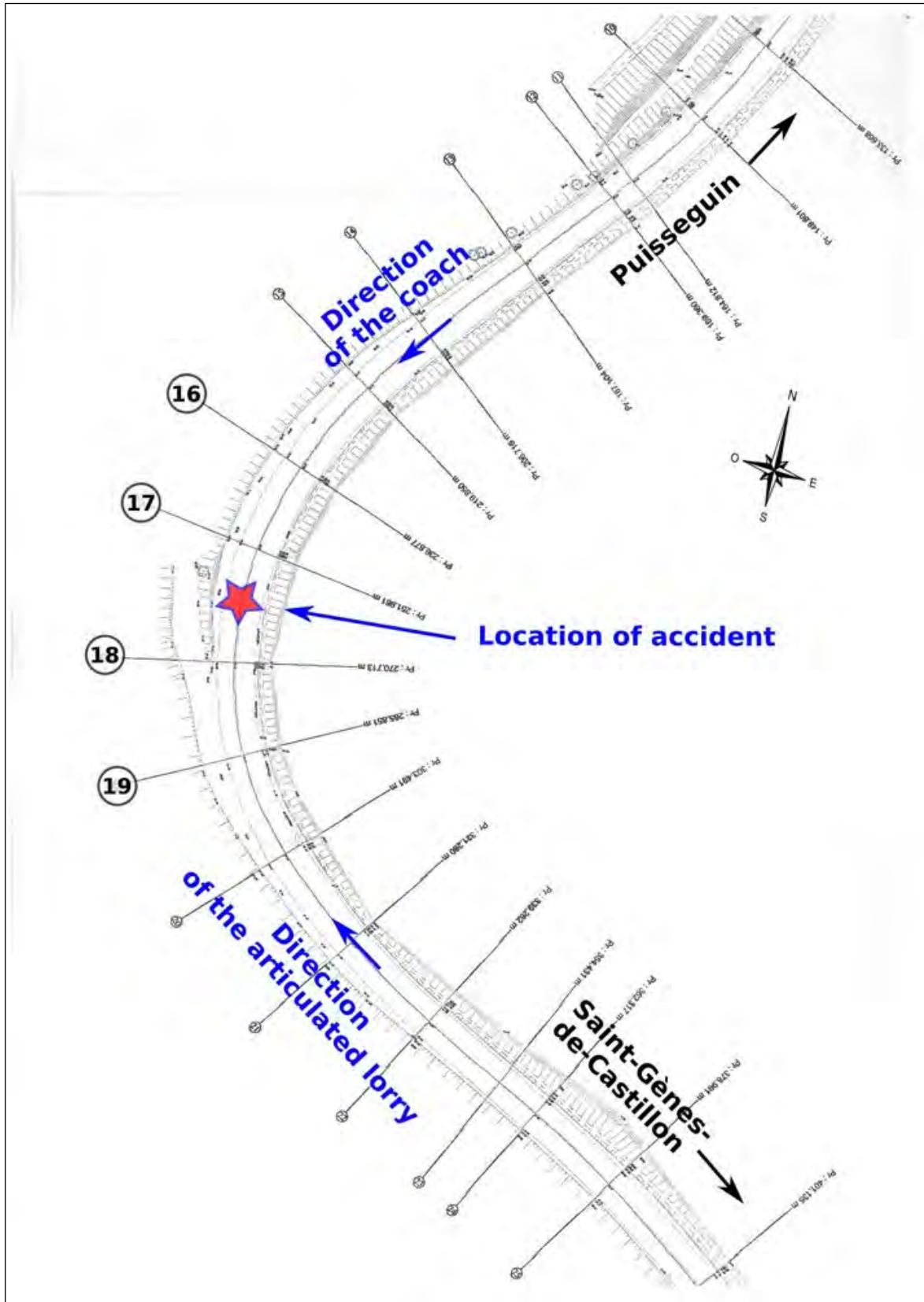




### Appendix 3: Aerial view of RD 17 in the area of the accident



# Appendix 4: Cross-sectional horizontal and vertical alignment of RD 17 at the accident site



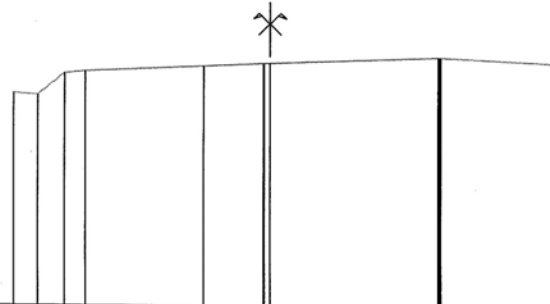
### Profil n°: 16

Abscisse : 236.88 m

Dévers Gauche 4.67 %  
Dévers Droite 4.01 %

Gisement : 324.96 gr

PC : 55.00 m



Altitudes TN		58.90	58.87	58.27	58.31		58.42	58.47		58.60	58.60
Distances à l'axe TN		-4.73	-4.28	-3.79	-3.41		-1.22	0.00		3.10	5.33
Distances partielles TN		0.45	0.49	0.38		2.19		1.22		3.10	2.23
Altitudes chaussée				58.29	58.31			58.47		58.60	58.59
Distances à l'axe chaussée				-3.62	-3.40			0.00		3.13	3.33
Distances partielles chaussée				0.22		3.40				3.13	0.21

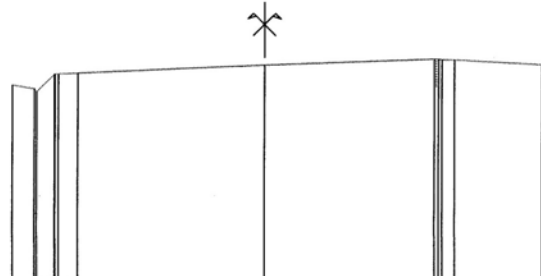
### Profil n°: 17

Abscisse : 251.96 m

Dévers Gauche 5.57 %  
Dévers Droite 4.52 %

Gisement : 312.24 gr

PC : 55.00 m



Altitudes TN		58.52	58.41	58.73	58.75		58.94		59.08	59.07	59.04	58.98
Distances à l'axe TN		-4.58	-4.14	-3.75	-3.39		0.00		3.09	3.45	5.04	5.25
Distances partielles TN		0.44	0.38	0.35		3.39			3.09	0.36	1.59	0.21
Altitudes chaussée				58.74	58.75		58.94		59.08	59.07		
Distances à l'axe chaussée				-3.57	-3.36		0.00		3.13	3.33		
Distances partielles chaussée				0.21		3.36			3.13	0.21		



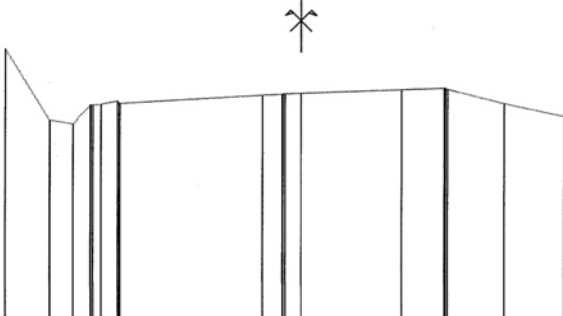
### Profil n°: 18

Abscisse : 270.71 m

Dévers Gauche 6.78 %  
Dévers Droite 4.73 %

Gisement : 290.17 gr

PC : 54.00 m



Altitudes TN		59.27		57.91		57.64		58.24		58.43		58.46		58.47		58.56		58.60		58.31		58.08
Distances à l'axe TN		-5.65		-4.80		-4.38		-3.46		-0.74		-0.31		0.00		1.92		2.73		3.87		5.01
Distances partielles TN		0.85		0.44		0.38		0.38		2.73		0.43		0.31		1.92		0.81		1.14		1.14
Altitudes chaussée						58.26		58.24				58.47						58.60		58.53		
Distances à l'axe chaussée						-3.65		-3.43				0.00						2.74		3.01		
Distances partielles chaussée						0.22				3.43						2.74		0.28		3.01		

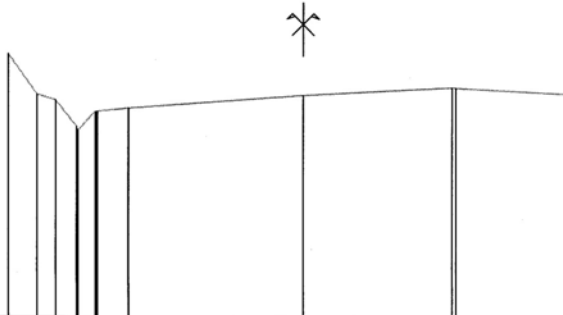
### Profil n°: 19

Abscisse : 285.85 m

Dévers Gauche 8.17 %  
Dévers Droite 5.70 %

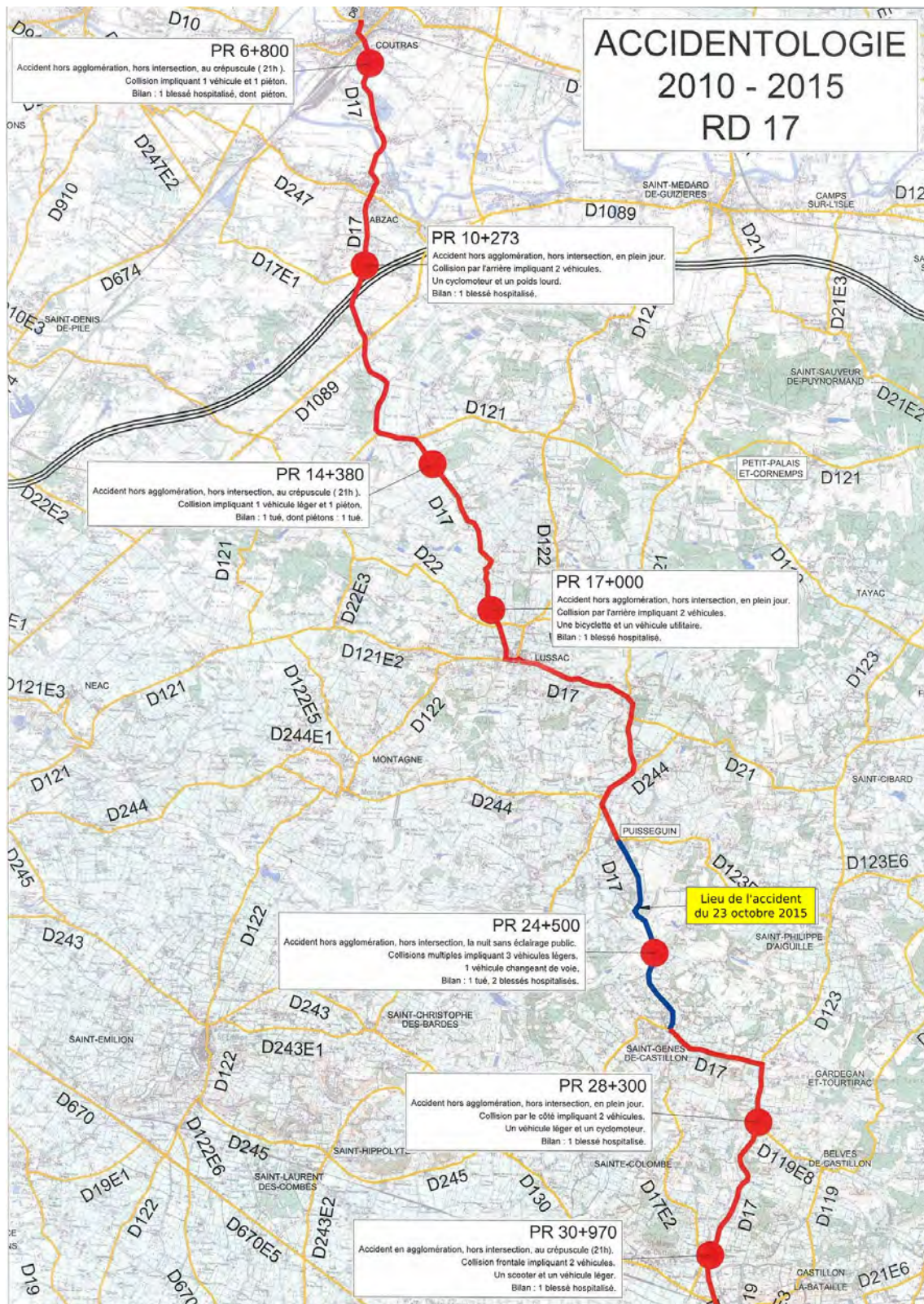
Gisement : 272.35 gr

PC : 54.00 m



Altitudes TN		58.89		58.14		58.04		57.83		57.90		58.16		58.33		58.31		58.23
Distances à l'axe TN		-5.49		-4.95		-4.61		-4.19		-3.83		-3.25		0.00		2.77		5.06
Distances partielles TN		0.54		0.34		0.48		0.36		0.58		3.25		2.77		2.29		
Altitudes chaussée						57.87		57.89				58.16		58.31				
Distances à l'axe chaussée						-3.49		-3.26				0.00		2.85		3.06		
Distances partielles chaussée						0.23				3.26				2.85		0.21		

## Appendix 5: Accident frequency rate on the RD 17 between 2010 and 2015

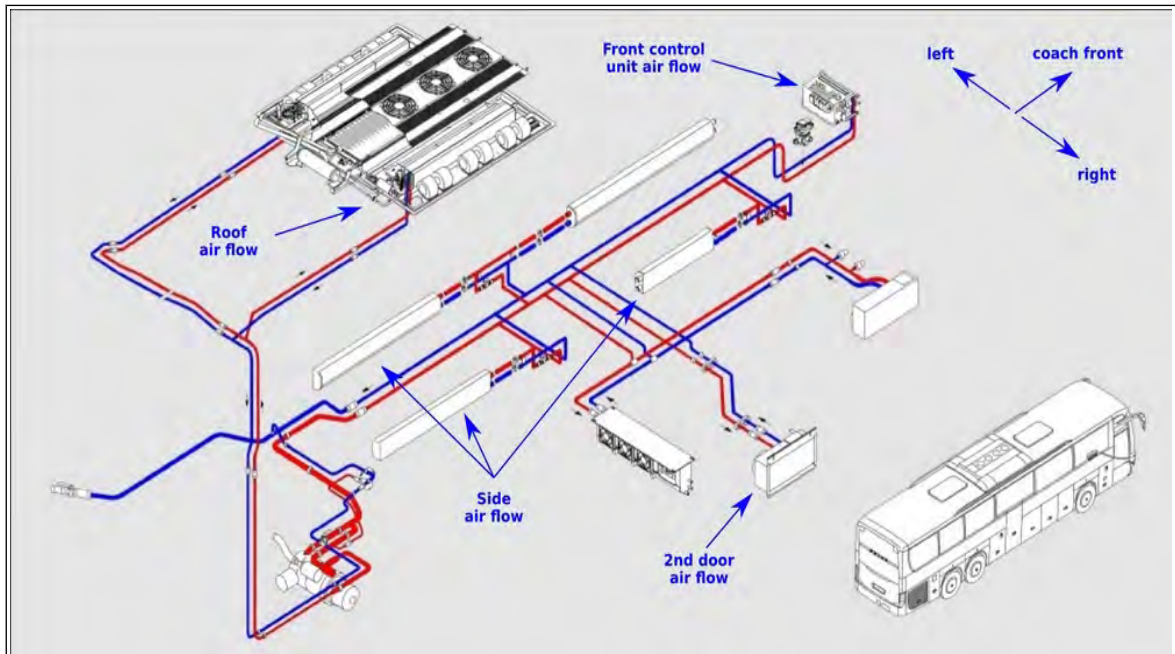




## Appendix 6: Description of the coach's heating and air conditioning systems

### Heating

Figure 89 below shows schematically the various components of the heating system as well as the routing of the ducts in which the heat transfer fluid circulates. Its key has been simplified to make it easier to read.

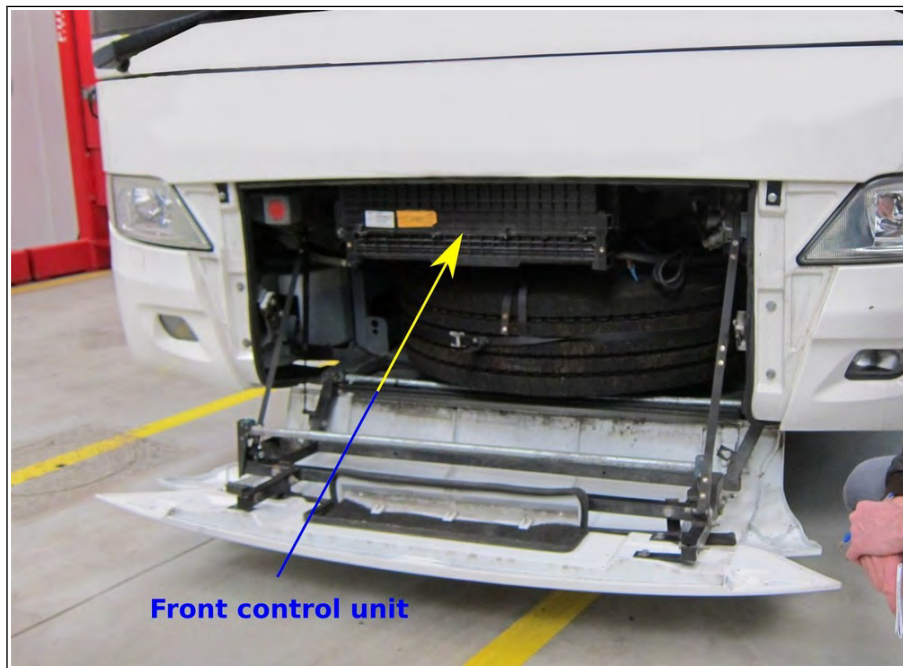


(VA document annotated by the BEA-TT)

**Figure 89: Schematic representation of the coach's heating system**

The front part of the coach and the driver's compartment are heated by means of a heat exchange and blower unit installed at the front of the vehicle.

This unit, referred to as "Front blower unit" in figure 89 is shown in an identical coach in figure 90 below.



(BEA-TT photo)

**Figure 90: View of the front heat exchange and blower unit on a similar coach**

## **Air conditioning**

The operation of the air conditioning system is based on the phase change of a refrigerant, the evaporation of which takes place with heat absorption and condensation with heat production.

The air conditioning system includes:

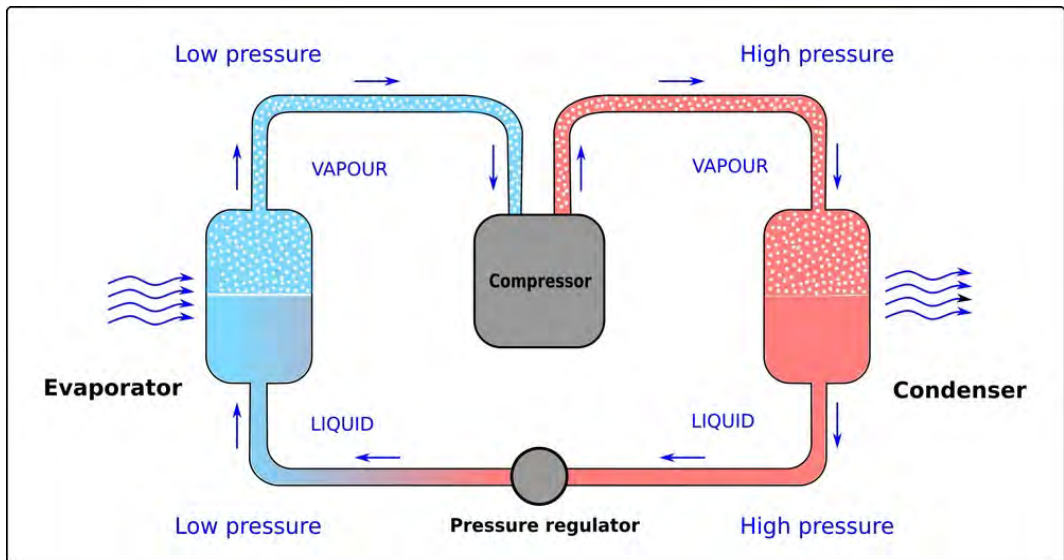
- a compressor compressing the gaseous fluid, thereby increasing its pressure and temperature;
- an exchanger/condenser where the gaseous fluid condenses and yields the heat thus produced to the ambient air;
- a pressure reducer in which a reduction in the pressure of the refrigerant liquid takes place;
- an evaporator exchanger in which the cooling of the refrigerant connected to its evaporation is transmitted to the air.

According to the manufacturer, the maximum pressures of the refrigerant are in normal operation (liquid state) at about 12 to 17 bars.

The minimum pressure in normal operation (gaseous state) is about 2 bar.

The pressures reached in the circuits depend on the ambient conditions and the level of use of the air conditioning.

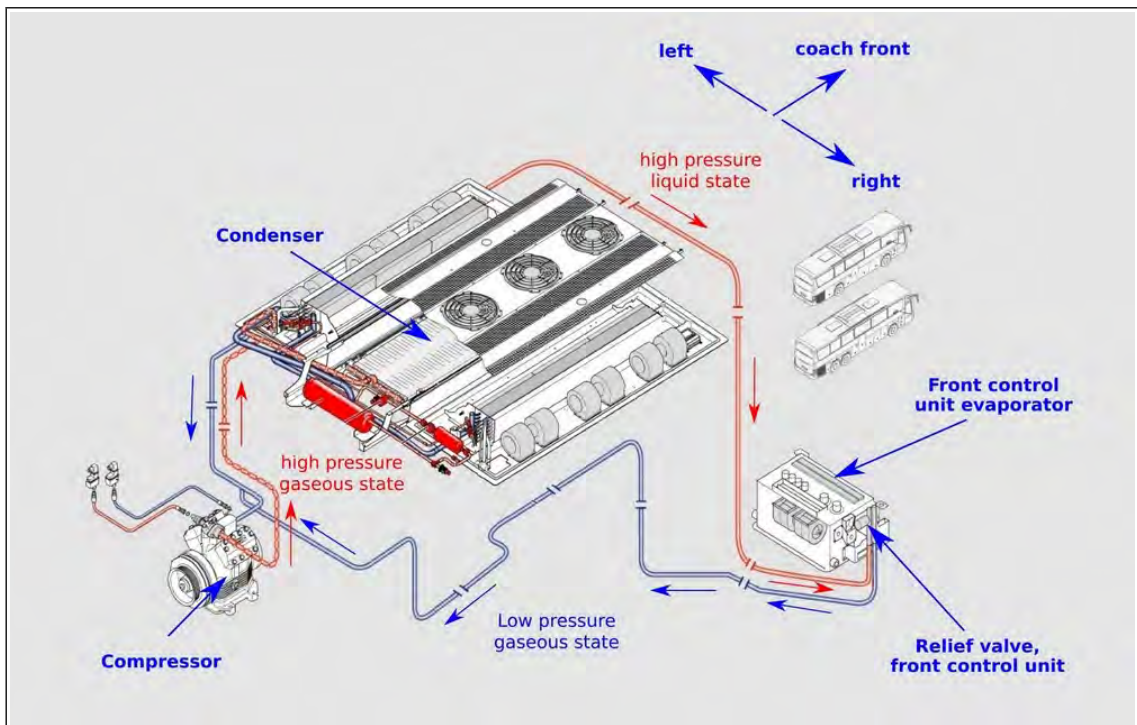
Figure 91 below illustrates the operating principle of the coach's air conditioning system.



**Figure 91: Principle of operation of the air conditioning system**

The air conditioning system of the coach includes an air handling unit installed on the roof of the vehicle and an evaporator installed in the heat exchange and arc chute installed at the front of the coach.

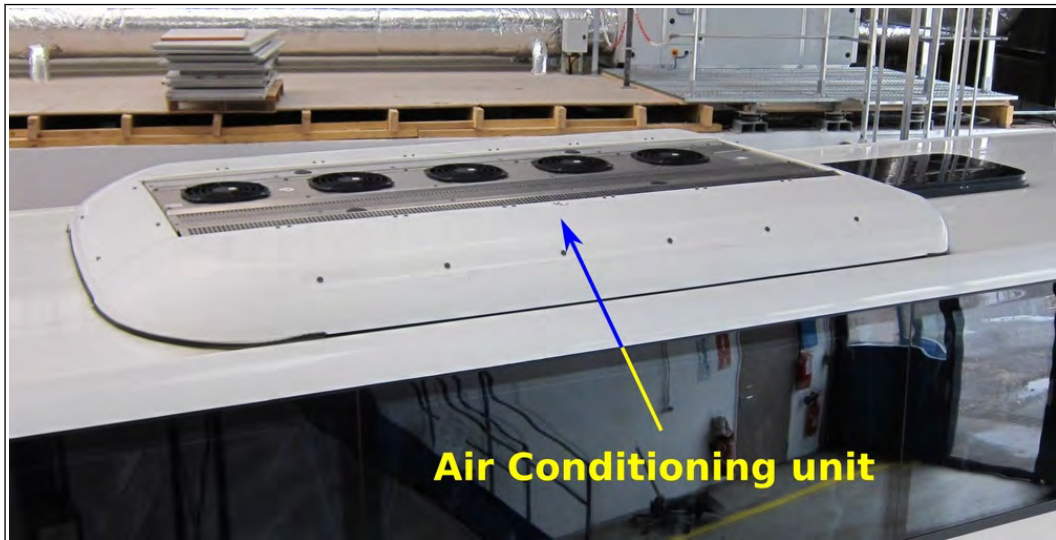
Figure 92 below shows schematically the air handling unit installed on the roof, the evaporator installed in the heat exchange and arc chute located at the front of the vehicle, and the flows and the different states of the refrigerant. Its key has been simplified to make it easier to read.



(VA document annotated by the BEA-TT)

**Figure 92: Schematic representation of the coach's air conditioning system**

Figure 93 below shows the installation of the air handling unit in an identical coach, located on the roof of the vehicle.




(BEA-TT photo)

**Figure 93: View of the air handling unit  
on the roof of a similar coach**



## Appendix 7: Extract from the safety data sheet for refrigerant R134a

	<b>FICHE DE DONNEES DE SECURITE</b>	
	<b>R134A</b>	
FDS N° : 178 IGS	Edition : 4 Date : 14/11/2011	Page 4 / 6

### 9 Propriétés physiques et chimiques

Etat physique :	Gaz liquéfié
Couleur :	Incolore
Odeur :	Légèrement éthérée
pH :	Non applicable
Températures caractéristiques :	
Point de fusion :	-101 °C
Point d'ébullition :	-26.4 °C
Température critique :	+101
Pression critique :	4070 kPa
Point d'éclair :	Néant
Taux d'évaporation	> 1 / CCl4
Inflammabilité (solide, gaz)	Ininflammable.
Limites d'inflammabilité dans l'air	Non applicable.
Pression de vapeur :	5.7 bar absolu à 20 °C 13.2 bar absolu à 50 °C
Densité de vapeur (air = 1)	3.6
Masse volumique :	1226 kg/m <sup>3</sup> à 20 °C 1103 kg/m <sup>3</sup> à 50 °C
Solubilité :	
- dans l'eau :	0.9 g/l
Coefficient de partage n-Octanol/eau :	1.06 (log Poe)
Température d'auto-inflammation	+743°C
Point de décomposition	> +370°C
Viscosité	Non applicable
Propriétés explosives	Non explosif selon les critères CE.
Propriétés comburantes	Non comburant selon les critères CE.

### 10 Stabilité et réactivité

Stabilité :	Stable à température ambiante et dans les conditions normales d'emploi.
Réactions dangereuses :	
Conditions à éviter :	En présence d'air, peut former, dans certaines conditions de température et de pression, un mélange inflammable.
Matières à éviter :	Alcalis et produits caustiques Métaux finement divisés (Al, Mg, Zn) Oxydants puissants Métaux alcalino-terreux
Produits de décomposition dangereux :	Par décomposition thermique (pyrolyse) libre : Fluorure d'hydrogène Oxydes de carbone (CO, CO <sub>2</sub> )

### 11 Informations toxicologiques

Toxicité aiguë :	Inhalation (rat) CL 50 [ppm /4h] : > 500000
Effets locaux :	Contact avec la peau : Non irritant par application cutanée chez le lapin. Contact avec les yeux : Non irritant par application oculaire chez le lapin.  Pas d'effet cancérigène. Pas d'effet mutagène. Pas d'effet tératogène.

INT. GAS & SERVICES N.V.  
De Veert 16 B-2830 Willebroek  
TEL. 0032/3.860.95.60 FAX. 0032/3.860.95.65 www.igs-cymaco.eu



## Appendix 8: Extract from the safety data sheet for Glysantin G48

page: 7/11

BASF Fiches de données de sécurité selon le règlement n° 1907/2006/CE

Date / mise à jour le: 12.08.2011

Version: 10.0

Produit: **Glysantin® G48®**

(ID Nr. 30159516/SDS\_GEN\_BE/FR)

date d'impression 13.08.2011

Etat physique:	liquide	
Couleur:	selon le cahier des charges	
Odeur:	spécifique du produit	
Température de solidification:	< -18 °C	(DIN ISO 3016)
Point d'ébullition:	>= 165 °C	(ASTM D1120)
Point d'éclair:	> 126,5 °C	(DIN EN 22719; ISO 2719)
Limite inférieure d'explosivité:	4,9 %(V)	
Limite supérieure d'explosivité:	14,6 %(V)	
Température d'auto-inflammation:	> 440 °C	(DIN 51794)
Pression de vapeur:	0,2 hPa (20 °C)	
Densité:	1,122 g/cm3 (20 °C)	(DIN 51757)
Solubilité (qualitative) solvant(s):	les solvants polaires soluble	
Viscosité, cinématique:	20 - 30 mm2/s (20 °C)	(DIN 51562)
Risque d'explosion:	aucune propriété explosive	

### Autres informations

Miscibilité avec l'eau:

miscible en toutes proportions

hygroscopie:

hygroscopique

Autres informations:

Si nécessaire, des informations sur d'autres paramètres physiques et chimiques sont indiqués dans cette section.

## 10. Stabilité et réactivité

### Réactivité

Corrosion des métaux: Non corrosif pour le métal.

### Stabilité chimique

Le produit est stable, lorsque les prescriptions/recommandations pour le stockage sont respectées.

Peroxydes: 0 %

Le produit ne contient pas de peroxydes.

### Possibilité de réactions dangereuses

Pas de réactions dangereuses lors d'un stockage et d'une manipulation conformes aux prescriptions.

### Conditions à éviter

Pas de conditions à éviter à attendre.

### Matières incompatibles

Produits à éviter:

oxydants puissants

# Appendix 9: Excerpts from the "TOTAL Diesel Premier" fuel safety data sheet



FDS n° : 080156

## TOTAL DIESEL PREMIER

Date de révision: 2013-08-20

Version 3.01

### Contrôles d'exposition liés à la protection de l'environnement

Informations générales Empêcher le produit de pénétrer dans les égouts, les cours d'eau ou le sol.

## 9. PROPRIÉTÉS PHYSIQUES ET CHIMIQUES

### 9.1. Informations sur les propriétés physiques et chimiques essentielles

Aspect		limpide	
Couleur		jaune	
État physique @20°C		Liquide	
Odeur		caractéristique	
<b>Propriété</b>	<b>Valeurs</b>	<b>Remarques</b>	<b>Méthode</b>
pH		Non applicable	
Point/intervalle d'ébullition	150 - 380 °C 302 - 716 °F		ASTM D 86 ASTM D 86
Point d'éclair	> 55 °C > 131 °F		ASTM D 93 ASTM D 93.
Taux d'évaporation		Non applicable	
Limites d'inflammabilité dans l'air			
supérieure	5 %		
inférieure	0.5 %		
Pression de vapeur	< 1 kPa @ 37.8 °C		EN 13016-1
Densité de vapeur	> 5		
Masse volumique	820 - 845 kg/m <sup>3</sup>	@ 15 °C	
Hydrosolubilité		Non applicable	
Solubilité dans d'autres solvants		Pas d'information disponible	
logPow		La substance est une UVCB. Les tests standard ne sont pas appropriés pour ce paramètre	
Température d'autoignition	> 250 °C > 482 °F		ASTM E659-78 ASTM E659-78
Viscosité, cinématique	< 7 mm <sup>2</sup> /s		
Propriétés explosives	Non considéré comme explosif sur la base de la teneur en oxygène et de la structure chimique		
Propriétés oxydantes	D'après la structure chimique des constituants, ce produit n'est pas considéré comme ayant des propriétés oxydantes		
Possibilité de réactions dangereuses	Donnée non disponible		

### 9.2. Autres informations

Pas d'information disponible

## 10. STABILITÉ ET RÉACTIVITÉ

### 10.1. Réactivité



FDS n° : 080156

**TOTAL DIESEL PREMIER**

Date de révision: 2013-08-20

Version 3.01

**Informations générales** Pas d'information disponible.**10.2. Stabilité chimique****Stabilité** Stable dans les conditions recommandées de manipulation et de stockage.**10.3. Possibilité de réactions dangereuses****Réactions dangereuses** Aucune dans les conditions normales d'utilisation.**10.4. Conditions à éviter****Conditions à éviter** La chaleur ( températures supérieures au point d'éclair ), les étincelles, les points d'ignition, les flammes, l'électricité statique.**10.5. Matières incompatibles****Matières à éviter** Oxydants forts. Acides forts. Bases fortes. (herbicides...), Halogènes.**10.6. Produits de décomposition dangereux****Produits de décomposition dangereux** Aucun dans les conditions normales d'utilisation.**11. INFORMATIONS TOXICOLOGIQUES****11.1. Informations sur les effets toxicologiques****Toxicité aiguë Effets locaux Informations sur le produit**

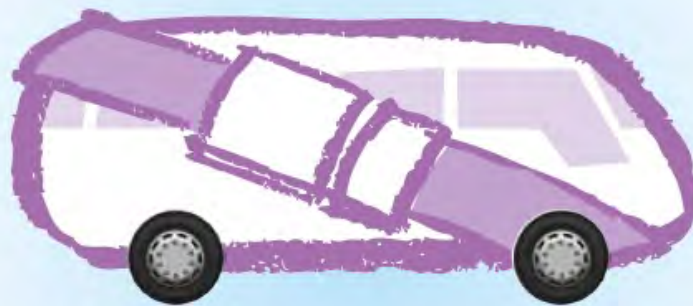
<b>Informations générales</b>	La toxicité aiguë a été correctement caractérisée dans un grand nombre de recherches réalisées conformément aux BPL suite à une exposition orale, cutanée ou par inhalation. La classification est basée sur les résultats d'une étude de toxicité aiguë par inhalation.
<b>Contact avec la peau</b>	Des échantillons de la substance ont été testés dans des études d'irritation cutanée. Basé sur un score d'érythème moyen de 3,9 et 2,5 (24, 72 heures) et un score d'œdème moyen de 2,96 et 1,5 (24, 72 heures), les gas oils sont irritants pour la peau. Peut causer des irritations de la peau et/ou dermatites.
<b>Contact avec les yeux</b>	Cette substance ne répond pas aux critères de classification de l'UE. Une étude clé a indiqué que le produit n'est pas irritant pour les yeux. Peut provoquer une irritation légère.
<b>Inhalation</b>	. L'inhalation de vapeurs à haute concentration peut provoquer une irritation du système respiratoire. Risque de dépression du système nerveux central avec nausées, maux de tête, vertiges, vomissements et perte de coordination.

Version EUFR

Appendix 10: Coach Passenger Safety Awareness Booklet published in 2016 by the FNTV

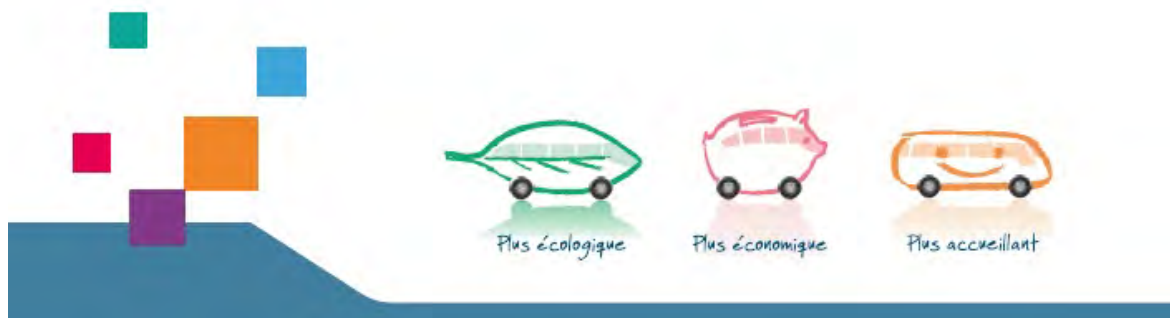


*Parce que votre sécurité est notre priorité*



Plus sûr

Pour voyager en toute tranquillité,  
prenez connaissance des consignes de sécurité !





# Règles de sécurité et de civilité à bord du véhicule



## *Le port de la ceinture de sécurité est obligatoire pour tous les passagers*

En cas de contrôle, le montant de l'amende s'élève à 135 € à la charge du passager.



## *Ne voyagez pas debout\**

Restez assis durant tout le trajet avec votre ceinture attachée.  
Ne vous levez qu'en cas d'extrême nécessité,  
et attendez l'arrêt complet de l'autocar lorsque vous souhaitez descendre.  
\*sauf pour certaines lignes où cela est spécifiquement autorisé.



## *Conservez l'allée centrale dégagée*

Tous les bagages, cartables ou effets personnels doivent être placés dans les porte-bagages situés au-dessus ou en dessous des sièges passagers.



## *Ne parlez pas au conducteur*

Tout conducteur doit se tenir constamment en état et en position d'exécuter commodément et sans délai toutes les manoeuvres qui lui incombent.



## *Il est interdit de fumer et de vapoter à bord du véhicule*

Articles L.3512-8 et L.3513-6 du Code de la santé publique.  
Fumer à bord du véhicule vous expose à une amende forfaitaire de 68 €.



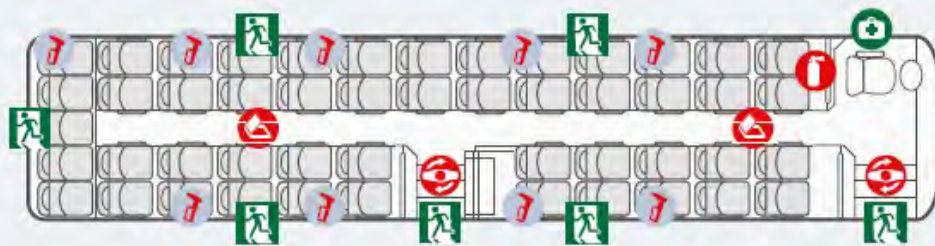
## *Ne dégradez pas le véhicule*

Tout acte d'incivilité, de dégradation ou de vandalisme est passible d'une contravention.





# Issues de secours et équipements de sécurité

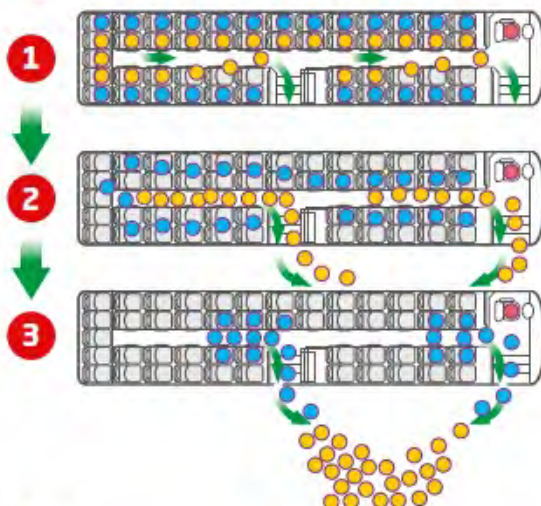


- |   |                     |   |                    |  |   |
|---|---------------------|---|--------------------|--|---|
|  | marteau brise-vitre |  | trousse de secours |  | système d'ouverture de secours des portes |
|  | trappe de toit      |  | extincteur         |  | Issue de secours                          |

www.graphibus.fr - réf 17/0019

# Consignes d'évacuation en cas d'urgence

## ➤ Évacuation par les portes :



Les passagers assis côté couloir ● se lèvent et s'intercalent dans le couloir, en commençant par les débuts de rangées.

Pendant que les passagers assis côté couloir évacuent dans le calme par les portes avant et arrière, les passagers assis côté fenêtre ● se décalent sur les places côté couloir laissées libres.

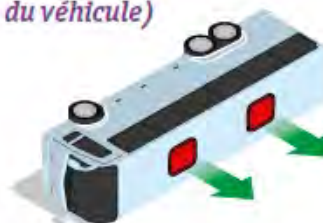
Ces derniers évacuent à leur tour l'autocar, en suivant les autres passagers dans le couloir, en partant du fond.

## ➤ Évacuation par les fenêtres :

Les vitres ne doivent être brisées qu'en cas de besoin



## ➤ Évacuation par les trappes de toit (en cas de renversement du véhicule)



*En cas d'évacuation, descendez de l'autocar dans le calme en laissant vos affaires personnelles, éloignez vous du véhicule et rassemblez vous dans un lieu sécurisé*

### Numéros d'appel d'urgence

<b>15</b> SAMU	<b>17</b> Police Gendarmerie	<b>18</b> Pompiers	<b>112</b> Toutes urgences
-------------------	------------------------------------	-----------------------	----------------------------------



Bureau d'Enquêtes sur les Accidents de Transport Terrestre  
Land Transport Accidents Investigation Bureau



**Grande Arche - Paroi Sud**  
**92055 La Défense cedex**  
Téléphone : 01 40 81 21 83  
Télécopie : 01 40 81 21 50  
[bea-tt@developpement-durable.gouv.fr](mailto:bea-tt@developpement-durable.gouv.fr)  
[www.bea-tt.developpement-durable.gouv.fr](http://www.bea-tt.developpement-durable.gouv.fr)

