

AGREEMENT

**CONCERNING THE ADOPTION OF UNIFORM TECHNICAL PRESCRIPTIONS
FOR WHEELED VEHICLES, EQUIPMENT AND PARTS WHICH CAN BE FITTED AND/OR
BE USED ON WHEELED VEHICLES AND THE CONDITIONS FOR RECIPROCAL RECOGNITION
OF APPROVALS GRANTED ON THE BASIS OF THESE PRESCRIPTIONS */**

(Revision 0)

Addendum 54-A: Regulation No. 55-

A Revision 0

Incorporating all valid text up to:

The 00 series of amendments - Date of entry into force: DD MMMM YYYY

**UNIFORM PROVISIONS CONCERNING THE APPROVAL OF MECHANICAL COUPLING
COMPONENTS OF COMBINATIONS OF AGRICULTURAL VEHICLES**



UNITED NATIONS

*/ Former title of the Agreement:

Agreement Concerning the Adoption of Uniform Conditions of Approval and Reciprocal Recognition of Approval for Motor Vehicle Equipment and Parts, done at Geneva on 20 March 1958.

GE.01-

Regulation No. 55-A

UNIFORM PROVISIONS CONCERNING THE APPROVAL OF MECHANICAL
COUPLING COMPONENTS OF COMBINATIONS OF AGRICULTURAL VEHICLES

CONTENTS

	<u>Page</u>
REGULATION	
1. Scope	5
2. Definitions	5
3. Application for approval of a mechanical coupling device or component.....	13
4. General requirements for mechanical coupling devices or components.....	14
5. Application for approval of a vehicle fitted with a mechanical coupling device or component.....	15
6. General requirements for vehicles fitted with a mechanical coupling device or component.....	16
7. Markings	16
8. Approval	17
9. Modifications of the mechanical coupling device or component, or of the vehicle and extension of approval.....	18
10. Conformity of production procedures.....	19
11. Penalties for non-conformity of production	19
12. Production definitely discontinued.....	19
13. Transitional provisions.....	19
14. Names and addresses of technical services responsible for conducting approval tests and of administrative departments	20

CONTENTS (continued)

ANNEXES

- Annex 1 - Communication concerning the approval or extension or refusal or withdrawal of approval or production definitely discontinued of a type of mechanical coupling device or component pursuant to Regulation No. 55-A
- Annex 2 - Communication concerning the approval or extension or refusal or withdrawal of approval or production definitely discontinued of a vehicle type with regard to the fitting of a mechanical coupling device or component pursuant to Regulation No. 55-A
- Annex 3 - Example of an arrangement of the approval mark
- Annex 4 - Examples of arrangements of marking of the characteristic values
- Annex 5 - Requirements for mechanical coupling devices or components vehicles of categories T, R and S
- Annex 6 - Testing of mechanical coupling devices or components for vehicles of categories T, R and S
- Annex 7 - Installation and special requirements

* * *

1. SCOPE

- 1.1. This Regulation lays down the requirements which mechanical coupling devices and components shall meet in order to be regarded internationally as being mutually compatible.
- 1.2. This Regulation applies to devices and components intended for vehicles of category T, R or S 2/ (agricultural vehicles) intended to form a combination of vehicles.
- 1.3. This Regulation applies to:
- 1.3.1. standard devices and components as defined in paragraph 2.3.;
- 1.3.2. non-standard devices and components as defined in paragraph 2.4.;
- 1.3.3. non-standard miscellaneous devices and components as defined in paragraph 2.5.
- 1.4. This regulation does not apply to power lifts (three-point hitch) or tractor lower link arms and their connections to the towed vehicle.

2. DEFINITIONS

For the purposes of this Regulation:

- 2.1. "mechanical coupling devices and components means" all those items on the frame, load-bearing parts of the bodywork and the chassis of the motor vehicle and trailer by means of which they are connected together to form the combination of vehicles or the articulated vehicles. Fixed or detachable parts for the attachment or operation of the mechanical coupling device or component are included.
- 2.2. standard mechanical coupling devices and components conform to standard dimensions and characteristic values as given in this Regulation. They are interchangeable within their class, independent of manufacturer with regard to mounting dimensions and may be connected to standard mechanical coupling devices and components of the appropriate class in accordance with annex 6.

1/ Within the meaning of the Convention on Road Traffic (Vienna, 1968, article 1, sub-paragraphs (t) and (u)).

2/ As defined in the Consolidated Resolution on the Construction of Vehicles (R.E.3.), document ECE/TRANS/WP.29/XXX www.unece.org/trans/main/wp29/wp29wgs/wp29gen/wp29resolutions.html

- 2.3. non-standard mechanical coupling devices and components do not conform in all respects to the standard dimensions and characteristic values given in this Regulation but can be connected to standard coupling devices and components in the relevant class.
- 2.4. non-standard miscellaneous mechanical coupling devices and components do not conform to standard dimensions and characteristic values as given in this Regulation and cannot be connected to standard coupling devices and components. They include, for example, devices which do not correspond with any of the Classes a to r listed in paragraph 2.5. such as those intended for special, heavy transport use and miscellaneous devices conforming to existing national standards.
- 2.5.1. Class a Coupling ball 80 and keeper plate employing a spherical device and brackets on the towing vehicle for connecting to the trailer by means of a ball-shaped scraper Coupling head 80 (ISO 24347:2005).
- 2.5.1.1. Class a80-1 Coupling ball 80 with standard flange-type bolted fixing.
- 2.5.1.2. Class a80-2 Coupling ball 80 with standard latching rail plate.
- 2.5.1.3. Class a80-X Coupling ball 80 with other fixing.
- 2.5.1.4 Class axxx Non-standard coupling ball with a diameter "xxx", always greater than 80 mm
- 2.5.2. Class b Coupling head 80, mounted on the drawbar of trailers for connecting to a coupling ball 80 on the towing vehicle (ISO 24347:2005).
- 2.5.2.1. Class b80-1 Coupling head 80 with standard welding shank.
- 2.5.2.2. Class b80-2 Coupling head 80 with standard horizontal flange-type bolted fixing.
- 2.5.2.3. Class b80-3 Coupling head 80 with standard horizontal flange-type bolted fixing.
- 2.5.2.4. Class b80-X Coupling head 80 with standard other fixing.
- 2.5.2.5 Class bxxx Non-standard coupling head with a diameter "xxx", always greater than 80 mm
- 2.5.3. Class c Clevis-type drawbar couplings with a pin (30 mm to 38 mm diameter), a jaw and an automatic or non-automatic closing and locking pin on the towing vehicle for connecting to the trailer by means of a coupling ring (ISO 6489-2:2002).
- 2.5.3.1. Class c40-1 Clevis-type drawbar couplings (30 mm to 38 mm diameter) with standard flange-type bolted fixing.
- 2.5.3.2. Class c40-2 Clevis-type drawbar couplings (30 mm to 38 mm diameter) with standard latching rail plate.
- 2.5.3.3. Class c40-X Clevis-type drawbar couplings (30 mm to 38 mm diameter) with other fixing.

- 2.5.4. Class d1 Drawbar eyes 40 having a cylindrical hole suitable for a pin (30 mm to 38 mm diameter) and a nominal thickness of 30,5 mm, and fitted to the drawbar of trailers for connecting to clevis-type couplings (ISO 8755:2001).
- 2.5.4.1. Class d1-40-1 Drawbar eyes (for a 30 mm to 38 mm diameter pin) with standard welding shank.
- 2.5.4.2. Class d1-40-2 Drawbar eyes (for a 30 mm to 38 mm diameter pin) for standard threaded attachment.
- 2.5.4.3. Class d1-40-3 Drawbar eyes (for a 30 mm to 38 mm diameter pin) with standard flange-type fixing.
- 2.5.4.4. Class d1-40-4 Drawbar eyes (for a 30 mm to 38 mm diameter pin) with other fixing.
- 2.5.4. Class d2 Drawbar eyes 40 having a cylindrical hole suitable for a pin (30 mm to 38 mm diameter) and a nominal thickness of 42 mm, fitted to the drawbar of a trailer for connecting to a clevis-type coupling (ISO 5692-2:2002).
- 2.5.5.1. Class d2-40-1 Drawbar eyes (for a 30 mm to 38 mm diameter pin) with standard welding shank.
- 2.5.5.2. Class d2-40-2 Not currently allocated.
- 2.5.5.3. Class d2-40-3 Drawbar eyes (for a 30 mm to 38 mm diameter pin) with standard flange-type fixing.
- 2.5.5.4. Class d2-40-4 Drawbar eyes (for a 30 mm to 38 mm diameter pin) with other fixing.
- 2.5.6. Class d3 Drawbar eyes having a hole with a circular cross-section and 50 mm diameter (hitch rings), which are fitted to trailer drawbars for connecting to a hitch hook (class g) or piton-type coupling (class h) (ISO 5692-1:2004).
- 2.5.6.1. Class d3-50-1 Drawbar eyes with standard welding shank.
- 2.5.6.2. Class d3-50-2 Drawbar eyes with standard flange-type fixing.
- 2.5.6.3. Class d3-50-3 Drawbar eyes with other fixing.
- 2.5.7. Class d4 Drawbar eyes having a hole with a 50 mm diameter, which are fitted to trailer drawbars for connecting to a hitch hook (class g) or a piton-type coupling (class h) (ISO 20019:2001).
- 2.5.7.1. Class d4-50-1 Drawbar eyes with standard welding shank.
- 2.5.7.2. Class d4-50-2 Drawbar eyes with standard flange-type bolted fixing.

- 2.5.7.3. Class d4-50-X Drawbar eyes with other fixing.
- 2.5.8. Class e Non-standard drawbars comprising forked and other drawbars, overrun devices and similar items of equipment mounted on the front of the towed vehicle, or on the vehicle chassis, which are suitable for coupling to the towing vehicle by means of coupling rings. Drawbar eyes, ball-shaped scrapers Coupling head or similar coupling devices.
- Drawbars may be hinged to move freely in a vertical plane and not support any vertical load or be fixed in a vertical plane so as to support a vertical load (rigid drawbars). Rigid drawbars can be entirely rigid or be spring-mounted or adjustably (e.g. hydraulically) mounted.
- Drawbars may also comprise more than one component and may be adjustable or cranked.
- 2.5.9. Class f Towing brackets, comprising all components and devices fitted between the coupling devices, for example coupling balls or clevis-type couplings, and the rear axle, transmission, load-bearing parts of the bodywork or chassis of the towing vehicle.
- 2.5.9.1. Class f-1 Towing brackets for standard quick height-adjustable (qha) latching rail plates.
- 2.5.9.2. Class f-2 Towing brackets for height-adjustable, detachable coupling devices.
- 2.5.9.3. Class f-X Other towing brackets.
- 2.5.10. Class g Hitch hooks with a keeper plate and a lowering device operated using external power for remote-controlled coupling and uncoupling for connecting to the trailer using hitch rings Drawbar eyes(ISO 6489-1:2001).
- 2.5.11. Class h Piton-type couplings with a keeper plate which are connected to the trailer by means of hitch rings Drawbar eyes(ISO 6489-4:2004).
- 2.5.12. Class i Drawbar couplings (pin 18 mm, 30 mm and 38 mm diameter) non-swivel around longitudinal axis (ISO 6489-3:2004)
- 2.5.12.1. Class i-18 Drawbar couplings with a pin of 18 mm diameter (ISO 6489-3:2004 Category 0)
- 2.5.12.2. Class i-30 Drawbar couplings with a pin of 30 mm diameter (ISO 6489-3:2004 Category 1 or 2)
- 2.5.12.3. Class i-38 Drawbar couplings with a pin of 38 mm diameter (ISO 6489-3:2004 Category 3)
- 2.5.13. Class p Non-standard mounting plates comprising all components and devices for attaching fifth wheel couplings to the frame or chassis of the towing vehicle. The mounting plate may have provision for moving horizontally, that is to form a sliding fifth wheel.

2.5.14.	Class q	Clevis-type drawbar couplings (pin 18 mm, 28mm, 43mm and 50 mm diameter) non-swivel around longitudinal axis (ISO 6489-5:2011)
2.5.14.1.	Class q1-18-1	Clevis-type drawbar coupling, non-swivel around longitudinal axis, with a pin of 18 mm diameter and with standard flange- type bolted fixing
2.5.14.2.	Class q1-18-2	Clevis-type drawbar coupling, non-swivel around longitudinal axis, with a pin of 18 mm diameter and with standard latching rail plate
2.5.14.3.	Class q1-18-X	Clevis-type drawbar coupling, non-swivel around longitudinal axis, with a pin of 18 mm diameter and with other fixing
2.5.14.4.	Class q2-28-1	Clevis-type drawbar coupling, non-swivel around longitudinal axis, with a pin of 28 mm diameter and with standard flange- type bolted fixing
2.5.14.5.	Class q2-28-2	Clevis-type drawbar coupling, non-swivel around longitudinal axis, with a pin of 28 mm diameter and with standard latching rail plate
2.5.14.6.	Class q2-28-X	Clevis-type drawbar coupling, non-swivel around longitudinal axis, with a pin of 28 mm diameter and with other fixing
2.5.14.7.	Class q3-43-1	Clevis-type drawbar coupling, non-swivel around longitudinal axis, with a pin of 43 mm diameter and with standard flange- type
2.5.14.8.	Class q3-43-2	Clevis-type drawbar coupling, non-swivel around longitudinal axis, with a pin of 43 mm diameter and with standard latching rail plate
2.5.14.9	Class q3-43-X	Clevis-type drawbar coupling, non-swivel around longitudinal axis, with a pin of 43 mm diameter and with other fixing
2.5.15.	Class r	Drawbar eye, swivel around longitudinal axis, having a circular cross-section (ISO 5692-3) and fitted to the drawbar of trailers for connection with non-swivel clevis type couplings (class q)
2.5.15.1.	Class r1-22-1	Not allocated
2.5.15.2.	Class r1-22-2	Drawbar eye, swivel around longitudinal axis, having a circular cross-section with an hole of 22 mm diameter and with threaded attachment
2.5.15.3.	Class r1-22-3	Drawbar eye, swivel around longitudinal axis, having a circular cross-section with an hole of 22 mm diameter and with standard flange type fixing
2.5.15.4.	Class r1-22-X	Drawbar eye, swivel around longitudinal axis, having a circular cross-section with an hole of 22 mm diameter and with other fixing
2.5.15.5.	Class r2-35-1	Not allocated

- 2.5.15.6. Class r2-35-2 Drawbar eye, swivel around longitudinal axis, having a circular cross-section with an hole of 35 mm diameter and with threaded attachment
- 2.5.15.7. Class r2-35-3 Drawbar eye, swivel around longitudinal axis, having a circular cross-section with an hole of 35 mm diameter and with standard flange type fixing
- 2.5.15.8. Class r2-35-X Drawbar eye, swivel around longitudinal axis, having a circular cross-section with an hole of 35 mm diameter and with other fixing
- 2.5.15.9. Class r3-50-1 Not allocated
- 2.5.15.10 Class r3-50-2 Drawbar eye, swivel around longitudinal axis, having a circular cross-section with an hole of 50 mm diameter and with threaded attachment
- 2.5.15.11 Class r3-50-3 Drawbar eye, swivel around longitudinal axis, having a circular cross-section with an hole of 50 mm diameter and with standard flange type fixing
- 2.5.15.12 Class r3-50-X Drawbar eye, swivel around longitudinal axis, having a circular cross-section with an hole of 50 mm diameter and with other fixing
- 2.5.16. Class s Coupling devices and components which do not conform to any of the classes a to r and which are used, for example, for special applications or are devices unique to some countries and covered by existing national standards.
- 2.6. Remote control systems are devices and components which enable the coupling device to be operated from the side of the vehicle or from the driving cab of the vehicle.
- 2.7. Remote indicators are devices and components which give an indication in the vehicle cab that coupling has been effected and that the locking devices have engaged.
- 2.8. "type of coupling device or component" means a device or component which does not essentially differ in such respects as:
- 2.8.1. the manufacturer's or supplier's trade name or mark;
- 2.8.2. the class of coupling as defined in paragraph 2.5.;
- 2.8.3. the external shape, principal dimensions or fundamental difference in design including materials used; and
- 2.8.4. the characteristic values D, D_c, S, V and U as defined in paragraph 2.11.
- 2.9. The characteristic values D, D_c, S, C, V and U are defined or determined as:
- 2.9.1. The D or D_c value is the theoretical reference value for the horizontal forces in the towing vehicle and the trailer and is used as the basis for horizontal loads in the dynamic tests.

For mechanical coupling devices and components not designed to support imposed vertical loads, the value is:

$$D = g \frac{TXR}{T+R} \text{ kN}$$

For mechanical coupling devices and components for rigid drawbar trailers as defined in 2.11., the value is:

$$D = g \frac{TXC}{T+C} \text{ kN}$$

where:

T is the technically permissible maximum mass of the towing vehicle, in tonnes. Where relevant, this includes the vertical load imposed by a rigid drawbar trailer. 2/

R is the technically permissible maximum mass, in tonnes, of a trailer with drawbar free to move in a vertical plane, or of a semitrailer. 2/

C is the mass, in tonnes, transmitted to the ground by the axle or axles of the rigid drawbar trailer, as defined in paragraph 2.11., when coupled to the towing vehicle and loaded to the technically permissible maximum mass 2/.

g is the acceleration due to gravity (assumed to be 9.81 m/s²)

S is as defined in paragraph 2.11.2.

2.9.2. The S value is the vertical mass, in kilograms, imposed on the coupling, under static conditions, by the rigid drawbar trailer, as defined in paragraph 2.13., of technically permissible maximum mass 2/.

2.9.3. The V value is the theoretical reference value of the amplitude of the vertical force imposed on the coupling by the rigid drawbar trailer of technically permissible maximum mass greater than 3.5 tonnes. The V value is used as the basis for vertical forces in the dynamic tests.

$$V = a \cdot C \cdot (x/l)^2$$

where:

a is an equivalent vertical acceleration at the coupling depending on the type of suspension system of the rear axle of the towing vehicle.

$$a = 1,8 \text{ m/s}^2$$

$$x/l = 1,2$$

2/ The mass T and R and the technically permissible maximum mass, may be greater than the permissible maximum mass prescribed by national legislation.

3/ See definitions in Regulation No. 13 annexed to the 1958 Agreement concerning the Adoption of Uniform Technical Prescriptions for Wheeled Vehicles, Equipment and Parts which can be Fitted and/or be Used on Wheeled Vehicles and the Conditions for Reciprocal Recognition of Approvals Granted on the Basis of these Prescriptions. The definition is also contained in annex 7 of the Consolidated Resolution on the Construction of Vehicles (R.E.3) (document TRANS/WP.29/78/Rev.1/Amend.2).

2.10. Symbols and definitions used in annex 6 of this Regulation.

- A_v = maximum permitted axle mass of the steered axle in tonnes.
- C = mass of rigid drawbar trailer in tonnes - see paragraph 2.11. of this Regulation.
- D = D value in kN - see paragraph 2.11. of this Regulation. D_c
= D_c value for rigid drawbar trailers - see paragraph 2.11. of this Regulation.
- R = mass of towed vehicle in tonnes - see paragraph 2.11. of this Regulation.
- T = mass of towing vehicle in tonnes - see paragraph 2.11. of this Regulation.
- F_a = static lifting force in kN.
- F_h = horizontal component of test force in longitudinal axis of vehicle in kN.
- F_s = vertical component of test force in kN.
- S = static vertical mass in kg.
- V = V-value in kN - see paragraph 2.9.3. of this Regulation.
- a = equivalent vertical acceleration factor at the coupling point of rigid drawbar trailers depending on the type of suspension of the rear axle(s) of the towing vehicle - see paragraph 2.9.3. of this Regulation.
- g = acceleration due to gravity, assumed as 9.81 m/s^2 .
- l = theoretical drawbar length between the centre of the drawbar eye and the centre of the axle assembly in metres.
- x = length of the loading area of a rigid drawbar trailer in metres.

Subscripts:

- O = maximum test force
- U = minimum test force
- a = static force
- h = horizontal
- p = pulsating
- res = resultant
- s = vertical
- w = alternating force

2.11. "Rigid drawbar trailer" means a towed vehicle with one axle or axle group, a drawbar which is not able to rotate relative to the vehicle or, due to the presence of a suspension system (for example), can only rotate to a limited extent about one axis - parallel to the road surface and transverse to the direction of

travel - and is therefore able to transmit vertical forces to the towing vehicle. A part of the weight of such a trailer is borne by the towing vehicle. A hydraulically adjustable articulated drawbar is considered to be a rigid drawbar 4/.

- 2.12. "Positive mechanical engagement" means that the design and geometry of a device and its component parts shall be such that it will not open or disengage under the action of any forces or components of forces to which it is subject during normal use or testing.
- 2.13. "Vehicle type" means vehicles which do not differ in such essential respects as the structure, dimensions, shape and materials in areas to which the mechanical coupling device or component is affixed. This applies to both the towing vehicle and trailer.
3. APPLICATION FOR APPROVAL OF A MECHANICAL COUPLING DEVICE OR COMPONENT
- 3.1. The application for approval shall be submitted by the holder of the trade name or mark or by his duly accredited representative.
- 3.2. For each type of mechanical coupling device or component the application shall be accompanied by the following information, for example, by means of the Communication form given in annex 1:
- 3.2.1. details of all manufacturer's or supplier's trade names or marks to be applied to the coupling device or component;
- 3.2.2. three sets of drawings which are sufficiently detailed to define the device or component and which specify how it is to be fitted to the vehicle; the drawings shall show the position and space provided for the approval number and other marking as given in paragraph 7.;
- 3.2.3. a statement of the values of D, D_c, S, and V as applicable and as defined in paragraph 2.11.
- 3.2.3.1. The characteristic values shall be at least equal to those applicable to the maximum permissible towing vehicle, trailer and combination masses.
- 3.2.4. a detailed technical description of the device or component, specifying, in particular, the type and the materials used;
- 3.2.5. one sample, plus additional samples as requested by the type approval authority or technical service;
- 3.2.6. all samples shall be fully finished with the final surface treatment applied. However, if the final treatment is by painting or epoxy powder coating, this should be omitted;
- 3.2.7. in the case of a mechanical coupling device or component designed for a specific vehicle type, the manufacturer of the device or component shall also submit the installation data given by the vehicle manufacturer. The approval authority or technical service may also request that a vehicle representative of the type be submitted.

4/ The technically permissible mass may be greater than the maximum permissible mass prescribed by national legislation

4. GENERAL REQUIREMENTS FOR MECHANICAL COUPLING DEVICES OR COMPONENTS

- 4.1. Each sample shall conform to the dimensional and strength specifications set out in annexes 5 and 6. Following the tests specified in annex 6 there shall not be any cracks, fractures or any excessive permanent distortion which would be detrimental to the satisfactory operation of the device or component.
- 4.2. All parts of the mechanical coupling device or component whose failure could result in separation of the vehicle and trailer shall be made of steel. Other materials may be used provided that equivalence has been demonstrated by the manufacturer to the satisfaction of the type approval authority or technical service of the Contracting Party applying this Regulation.
- 4.3. The mechanical coupling devices or components shall be safe to operate and coupling and uncoupling shall be possible by one person without the use of tools.
- 4.4. The mechanical coupling devices or components shall be designed and manufactured such that in normal use and with correct maintenance and replacement of wearing parts they will continue to function satisfactorily and retain the characteristics prescribed by this Regulation.
- 4.5. All mechanical coupling devices or components shall be designed to have positive mechanical engagement and the closed position shall be locked at least once by further positive mechanical engagement unless further requirements are stated in annex 5. Alternatively there may be two or more separate arrangements to ensure the integrity of the device but each arrangement shall be designed to have positive mechanical engagement and shall be tested individually to any requirements given in annex 6. Positive mechanical engagement shall be as defined in paragraph 2.12.

Spring forces may be used only to close the device and to prevent the effects of vibration from causing component parts of the device to move to positions where it may open or disengage.

The failure or omission of any one single spring shall not allow the complete device to open or disengage.

- 4.6. Every device or component shall be accompanied by installation and operating instructions giving sufficient information for any competent person to install it correctly on the vehicle and operate it properly - see also annex 7. The instructions shall be in at least the language of the country in which it will be offered for sale. In the case of devices and components supplied for original equipment fitting by a vehicle manufacturer or bodybuilder, installation instructions may be dispensed with but the vehicle manufacturer or bodybuilder will be responsible for ensuring that the vehicle operator is supplied with the necessary instructions for correct operation of the coupling device or component.
- 4.7. Quick height-adjustable towing devices with no power assistance may not exceed an operating force of [40] daN.

5. APPLICATION FOR APPROVAL OF A VEHICLE FITTED WITH A MECHANICAL COUPLING DEVICE OR COMPONENT

- 5.1. Where a vehicle manufacturer applies for approval of a vehicle fitted with a mechanical coupling device or component or authorises the use of a vehicle for towing any form of trailer, then, at the request of a bona fide applicant for possible type approval for a mechanical coupling device or component, or of the type approval authority or technical service of a Contracting Party, the vehicle manufacturer shall readily make available to that inquirer or authority or technical service, such information as required in

paragraph 5.3. below, to enable a manufacturer of a coupling device or component to properly design and manufacture a mechanical coupling device or component for that vehicle. At the request of a bona fide applicant for possible type approval for a mechanical coupling device or component, any information given in paragraph 5.3. below which is held by the type approval authority shall be released to that applicant.

- 5.2. The application for approval of a vehicle type with regard to the fitting of a mechanical coupling device or component shall be submitted by the vehicle manufacturer or by his duly accredited representative.
- 5.3. It shall be accompanied by the following information to enable the type approval authority to complete the communication form given in annex 2.
 - 5.3.1. a detailed description of the vehicle type and of the mechanical coupling device or component and, at the request of the type approval authority or technical service, a copy of the approval form for the device or component;
 - 5.3.2. The information shall also include the maximum permissible masses of the towing and towed vehicles, the distribution of the maximum permissible mass of the towing vehicle between the axles, the maximum permissible axle masses, the maximum permissible vertical loading to be imposed on the rear of the towing vehicle and details and/or drawings of the installation mounting points for the device or component and of any additional reinforcing plates, support brackets and so on, necessary for safe attachment of the mechanical coupling device or component to the towing vehicle;
 - 5.3.3. three sets of drawings which are sufficiently detailed to identify the device or component and which specify how it is to be fitted to the vehicle; the drawings shall show the position and space provided for the approval number and other marking as given in paragraph 7.;
 - 5.3.4. a detailed technical description of the device or component, specifying, in particular, the type and the materials used;
 - 5.3.5. a statement of the values of D, D_c, S, and V as applicable and as defined in paragraph 2.11.;
 - 5.3.5.1. The characteristic values shall be at least equal to those applicable to the maximum permissible towing vehicle, trailer and combination masses.
 - 5.3.6. a vehicle, representative of the type to be approved and fitted with a mechanical coupling device, shall be submitted to the type approval authority or technical service which may also request additional samples of the device or component;
 - 5.3.7. a vehicle not having all of the components appropriate to the type may be accepted provided that the applicant can show, to the satisfaction of the type approval authority or technical service, that the absence of the components does not have any effect on the results of the inspection as far as the requirements of this Regulation are concerned.
 - 5.3.8.
6. GENERAL REQUIREMENTS FOR VEHICLES FITTED WITH A MECHANICAL COUPLING DEVICE OR COMPONENT
 - 6.1. The mechanical coupling device or component fitted to the vehicle shall be approved in accordance with the requirements of paragraphs 3 and 4 and annexes 5 and 6 of this Regulation.
 - 6.2. The installation of the mechanical coupling device or component

shall meet the requirements of annex 7 paragraph 3 to this Regulation.

6.3. All tractors with a loaded mass exceeding 2,5 tonnes must be fitted with a trailer coupling having a ground clearance satisfying one of the following relations:

6.4. Operating instructions shall be provided for use of the coupling device or component which shall contain any special instructions for operations which are different from those normally associated with the type of coupling device or component and instructions for coupling and uncoupling with different modes of operation, for example, at various angles between the towing and towed vehicles. Each vehicle shall be accompanied by these operating instructions.

7. MARKINGS

7.1. Types of mechanical coupling devices and components submitted for approval shall bear the trade name or mark of the manufacturer, supplier or applicant.

7.2. There shall be a sufficiently large space for application of the approval mark referred to in paragraph 8.5. and shown in annex 3. This space shall be shown on the drawings referred to in paragraph 3.2.2.

7.3. Adjacent to the approval mark referred to in paragraphs 7.2. and 8.5., the mechanical coupling device or component shall be marked with the class of coupling, as defined in paragraph 2.5. and the relevant characteristic values as defined in paragraph 2.9. and shown in annex 4. The position for these markings shall be shown on the drawings referred to in paragraph 3.2.2.

7.4. Where the mechanical coupling device or component is approved for alternative characteristic values within the same class of coupling or device, a maximum of two alternatives shall be marked on the device or component.

7.5. If the application of the mechanical coupling device or component is restricted in any way, for example, if it is not to be used with steering wedges, then that restriction shall be marked on the device or component.

7.6. All markings shall be permanent and legible when the device or component is installed on the vehicle.

8. APPROVAL

8.1. If the sample(s) of a type of mechanical coupling device or component meets (meet) the requirements of this Regulation, approval shall be granted subject to the requirements of paragraph 10. being satisfactorily met.

8.2. An approval number shall be assigned to each type approved. Its first two digits (at present 00) shall indicate the series of amendments incorporating the most recent major technical amendments made to the Regulation at the time of issue of the approval. The same Contracting Party may not assign the same number to another type of device or component referred to in this Regulation.

8.3. Notice of approval or of extension, refusal or withdrawal of approval or of production definitely discontinued, relating to a type of mechanical coupling device or component approved pursuant to this Regulation, shall be communicated to the Parties to the 1958 Agreement applying this Regulation, by means of a communication form conforming to the model in either annex 1 or annex 2 to this Regulation.

8.4. In addition to the mark prescribed in paragraph 7.1., there shall

be affixed to every mechanical coupling device or component approved under this Regulation, in the space referred to in paragraph 7.2., an approval mark as described in paragraph 8.5.

- 8.5. The approval mark shall be an international mark comprising:
 - 8.5.1. a circle surrounding the letter "E" followed by the distinguishing number of the country which has granted approval 5;
 - 8.5.2. the approval number prescribed in paragraph 8.2.;
 - 8.5.3. a capital letter D when tested according to Annex 6 paragraph 3.1.3 (dynamic endurance test) or
 - 8.5.4. a capital letter S when tested according to Annex 6 paragraph 3.3.3.2 (static test);
 - 8.5.5. the approval mark and number shall be arranged as shown in the example in annex 3.
9. MODIFICATIONS OF THE MECHANICAL COUPLING DEVICE OR COMPONENT, OR OF THE VEHICLE AND EXTENSION OF APPROVAL
 - 9.1. Any modification to the type of mechanical coupling device or component, or of the vehicle as defined in paragraph 2.10. shall be notified to the type approval authority or technical service which granted the approval. The type approval authority or technical service may then either:
 - 9.1.1. consider that the modifications are unlikely to have any appreciable adverse effect and that in any case the device, component or vehicle still conforms to requirements; or
 - 9.1.2. require a further test report.
 - 9.2. Confirmation of, or refusal of approval, specifying the modification, shall be communicated by the procedure prescribed in paragraph 8.3. to the Contracting Parties applying this Regulation.
 - 9.3. The type approval authority or technical service issuing an extension of approval shall assign a series number for such an extension and shall inform the other Contracting Parties applying this Regulation by the procedure prescribed in paragraph 8.3.
10. CONFORMITY OF PRODUCTION PROCEDURES

The conformity of production procedures shall comply with those set out in the Agreement, Appendix 2 (E/ECE/324 - E/ECE/TRANS/505/Rev.2), with the following requirements:

 - 10.1. The holder of the approval must ensure that results of the conformity of production tests are recorded and that the annexed documents remain available for a period determined in agreement with the approval authority or technical service. This period must not exceed 10 years counted from the time when production is definitely discontinued.
 - 10.2. The type approval authority or technical service which has granted type approval may at any time verify the conformity control methods applied in each production facility. The normal frequency of these verifications shall be once every two years.
11. PENALTIES FOR NON-CONFORMITY OF PRODUCTION
 - 11.1. The approval granted in respect of a type of mechanical coupling device or component pursuant to this Regulation may be withdrawn if the requirements are not complied with or if a device or component bearing the approval mark does not conform to the type approved.

11.2. If a Contracting Party to the Agreement applying this Regulation withdraws an approval it has previously granted, it shall forthwith so notify the other Contracting Parties applying this Regulation by means of a communication form conforming to the model in either annex 1 or annex 2 to this Regulation.

12. PRODUCTION DEFINITELY DISCONTINUED

If the holder of the approval completely ceases to manufacture a type of mechanical coupling device or component approved in accordance with this Regulation, he shall so inform the type approval authority or technical service which granted the approval. Upon receiving the relevant communication, that type approval authority or technical service shall inform thereof the other Contracting Parties to the 1958 Agreement applying this Regulation by means of a communication form conforming to the model in either annex 1 or annex 2 to this Regulation.

13. TRANSITIONAL PROVISIONS

Until the United Nations Secretary-General is notified otherwise, Contracting Parties applying this Regulation that are Member States of the European Community (at the time of adoption of the 01 series of amendments, Italy, Netherlands, Belgium, United Kingdom, Luxembourg, Finland and Greece) declare that, in relation to mechanical coupling devices and components, they will only be bound by the obligations of the Agreement to which this Regulation is annexed with respect to such devices and components intended for vehicles of categories other than M₁.

14 NAMES AND ADDRESSES OF TECHNICAL SERVICES RESPONSIBLE FOR APPROVAL TESTS AND OF ADMINISTRATIVE DEPARTMENTS

14.1. The Contracting Parties to the 1958 Agreement applying this Regulation shall communicate to the United Nations Secretariat the names and addresses of the technical services responsible for conducting approval tests and of the administrative departments which grant approval and to which forms certifying approval or extension or refusal or withdrawal of approval, or production definitely discontinued, issued in other countries, are to be sent.

5/ 1 for Germany, 2 for France, 3 for Italy, 4 for the Netherlands, 5 for Sweden, 6 for Belgium, 7 for Hungary, 8 for the Czech Republic, 9 for Spain, 10 for Yugoslavia, 11 for the United Kingdom, 12 for Austria, 13 for Luxembourg, 14 for Switzerland, 15 (vacant), 16 for Norway, 17 for Finland, 18 for Denmark, 19 for Romania, 20 for Poland, 21 for Portugal, 22 for the Russian Federation, 23 for Greece, 24 for Ireland, 25 for Croatia, 26 for Slovenia, 27 for Slovakia, 28 for Belarus, 29 for Estonia, 30 (vacant), 31 for Bosnia and Herzegovina, 32 for Latvia, 33 (vacant), 34 for Bulgaria, 35-36 (vacant), 37 for Turkey, 38-39 (vacant), 40 for The former Yugoslav Republic of Macedonia, 41 (vacant), 42 for the European Community (Approvals are granted by its Member States using their respective ECE symbol), 43 for Japan, 44 (vacant), 45 for Australia, 46 for Ukraine and 47 for South Africa. Subsequent numbers shall be assigned in the chronological order in which they ratify or accede to the Agreement concerning the Adoption of Uniform Technical Prescriptions for Wheeled Vehicles, Equipment and Parts which can be Fitted and/or be Used on Wheeled Vehicles and the Conditions for Reciprocal Recognition of Approvals Granted on the Basis of these Prescriptions, or in which they accede to the Agreement, and the numbers thus assigned shall be communicated by the Secretary-General of the United Nations to the Contracting Parties to the Agreement.

Annex 1

COMMUNICATION

(maximum format: A4 (210 x 297 mm))

issued by: Name of administration:
.....
.....
.....



concerning: 2/ APPROVAL GRANTED
APPROVAL EXTENDED
APPROVAL REFUSED
APPROVAL WITHDRAWN
PRODUCTION DEFINITELY DISCONTINUED

of a type of mechanical coupling device or component pursuant to Regulation No. 55

Approval No Extension No

1. Trade name or mark of the device or component:
.....
2. Manufacturer's name for the type of device or component:
.....
3. Manufacturer's name and address:
.....
.....

1/ Distinguishing number of the country which has granted/extended/refused/withdrawn approval (see approval provisions in the Regulation).

2/ Strike out what does not apply.

4. If applicable, name and address of the manufacturer's representative:
.....
.....
5. Alternative supplier's names or trademarks applied to the device or component:
.....
.....
6. Name and address of company or body taking responsibility for the conformity of production:
.....
.....
7. Submitted for approval on:
8. Technical service responsible for conducting approval tests:
.....
9. Brief description:
 - 9.1. Type and class of device or component:
.....
 - 9.2. Characteristic values:
 - 9.2.1. Primary values:
D..... kN D_c kN S..... kg
V..... kN v_{max}km/h
Alternative values:
D..... kN D_c kN S..... kg
V..... kN v_{max}km/h
10. Instructions for the attachment of the coupling device or component type to the vehicle and photographs or drawings of the mounting points given by the vehicle manufacturer:
.....
.....
11. Information on the fitting of any special reinforcing brackets or plates or spacing components necessary for the attachment of the coupling device or component:
.....
.....
.....
14. Date of test report:

- 15. Number of test report:
- 16. Approval mark position:
- 17. Reason(s) for extension of approval:
.
- 18. Approval granted/extended/refused/withdrawn: 2/
- 19. Place:
- 20. Date:
- 21. Signature:
- 22. The list of documents deposited with the Administration Service
which has granted approval is annexed to this communication and may
be obtained on request.
.
.
.
.



Annex 2

COMMUNICATION

(maximum format: A4 (210 x 297 mm))

issued by: Name of administration:
.....
.....
.....



concerning: 2/ APPROVAL GRANTED
APPROVAL EXTENDED
APPROVAL REFUSED
APPROVAL WITHDRAWN
PRODUCTION DEFINITELY DISCONTINUED

of a vehicle type with regard to the fitting of a mechanical coupling device or component pursuant to Regulation No. 55

Approval No..... Extension No

1. Trade name or mark of vehicle:
2. Vehicle type:
3. Manufacturer's name and address:
4. If applicable, name and address of the manufacturer's representative:
5. Vehicle category, for example, T, R:

1/ Distinguishing number of the country which has granted/extended/refused/withdrawn approval (see approval provisions in the Regulation).

2/ Strike out what does not apply.

6. Maximum permissible vehicle mass: kg
Distribution of maximum permissible vehicle mass between the axles:
.
Maximum permissible towable trailer mass: kg
Maximum permissible static vertical load on coupling ball: kg
Maximum mass of the vehicle, with bodywork, in running order, including
coolant, oils, fuel, tools and spare wheel (if supplied) but not including
driver:
. kg
7. D..... kN D_c kN S..... kg
V..... kN v_{max}km/h
8. Instructions for the attachment of the coupling device or component type
to the vehicle and photographs or drawings of the mounting points:
.
.
9. Information on the fitting of any special reinforcing brackets or plates
or spacing components necessary for the attachment of the coupling device
or component:
.
.
10. Trade name or mark of the mechanical coupling device or component and the
approval number:
.
11. Class of coupling device or component:
12. Submitted for approval on:
13. Technical service responsible for conducting approval tests:
.
14. Date of test report:
15. Number of test report:
16. Approval mark position:
17. Reason(s) for extension of approval:

18. Approval granted/extended/refused/withdrawn: 2/

19. Place:

20. Date:

21. Signature:

22. The list of documents deposited with the Administration Service which has granted approval is annexed to this communication and may be obtained on request.

.
.
.
.

Annex 3

EXAMPLE OF AN ARRANGEMENT OF THE APPROVAL MARK

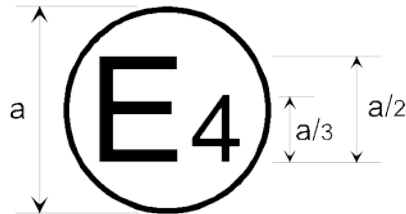

55AR - 002405S \updownarrow a/3

a = 8 mm minimum

The mechanical coupling device or component or vehicle bearing the approval mark shown above is a device or component approved in the Netherlands (E4), under approval number 2405, meeting the requirements of the 00 series of amendments to this Regulation and was tested statically (S).

Note: The approval number and additional symbols shall be placed close to the circle and either above or below the letter 'E', or to the right or left of that letter. The digits of the approval number shall be on the same side of the letter 'E' and face in the same direction. The use of Roman numerals as approval numbers should be avoided so as to prevent any confusion with other symbols.

Annex 4

EXAMPLES OF ARRANGEMENTS OF MARKING OF THE CHARACTERISTIC VALUES

1. All mechanical coupling devices or components shall be marked with the class of the device or component. In addition there shall be marking to indicate the capacity in terms of characteristic values as defined in paragraph 2.11. of this Regulation.
- 1.1. The height of all letters and numbers shall be not less than those of the approval number, that is $a/3$ where a is 8 mm.
- 1.2. The characteristic values applicable to each device or component which are to be marked are as shown in the table below - see also paragraph 7.3. of this Regulation:

Table 1 - Relevant characteristics values to be marked on agricultural coupling devices or components

Description of mechanical coupling device or component	Characteristic values to be marked						
	Class	D	D _c	S	V	V _{max}	T ₁ /
Coupling balls 80 (Class a)	X	X	X	X	-	X	-
Coupling head (Class b)	X	X	X	X	X	X	-
Clevis-type couplings (Class c or q)	X	X	X	X	-	X	X
Hook-type couplings (Class g)	X	X	X	X	-	X	-
Tractor drawbars (Class i)	X	X	X	X	-	X	X
Towing brackets (Class f)	X	X	X	X	-	X	-
Piton-type couplings (Class h)	X	X	X	X	-	X	-
Drawbar eyes Class d or r)	X	X	X	X	X	X	X
Drawbars (Class e)	X	X	X	X	X	X	-

1/ Towable mass when tested according to annex 6 paragraph 3.3.3.2. (static test)

Examples: a80-2 D130 D_c90 S2000 would identify a standard coupling ball 80 of Class a80-2 with a maximum D value of 130 kN, a maximum permitted D_c value of 90 kN and a maximum permitted static vertical imposed load of 2,000 kg.

Annex 5

REQUIREMENTS FOR MECHANICAL COUPLING DEVICES OR COMPONENTS
FOR VEHICLES OF CATEGORIES T, R AND S

1. Coupling balls 80 and keeper plates
 - 1.1. General requirements for coupling balls 80
 - 1.1.1. All coupling balls 80 and keeper plates shall be designed such that the coupling balls satisfy the tests prescribed in paragraph 3.1 of annex 6 and keeper plates satisfy the tests prescribed in paragraph 3.3.5 of annex 6.
 - 1.1.2. Coupling balls 80 of Class a shall conform to Figure 1 in external shape and external dimensions. The position of the keeper plate is shown in Figure 2. The dimensions given in Figures 1 and 2 are identical to ISO 24347:2005.

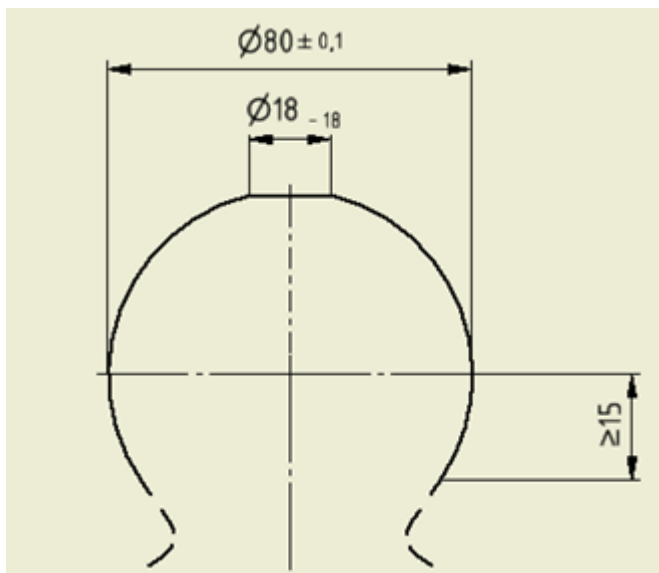

Figure 1 - Ball dimensions

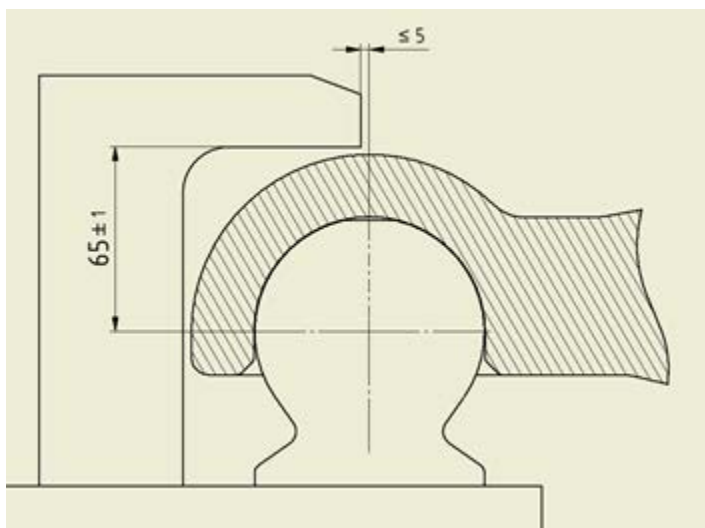
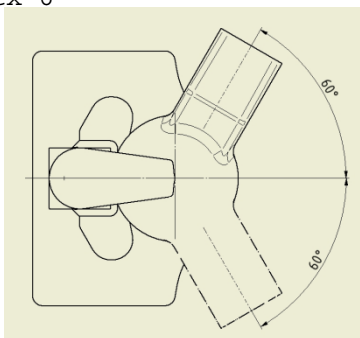
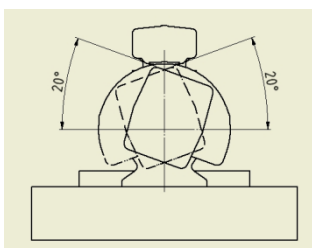

Figure 2 - Keeper plate dimensions

- 1.1.1.3. The coupling balls 80 shall have at least the following angles of articulation, which do not have to be reached simultaneously:



Vertical axis: $\pm 60^\circ$



Longitudinal axis: $\pm 20^\circ$

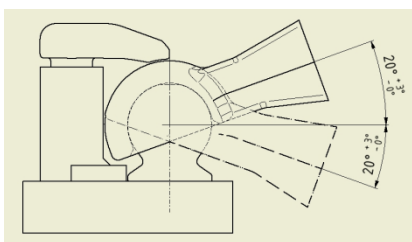

Transverse axis: $\pm 20^\circ$

Figure 3: Angles of articulation

1.2. Coupling balls 80 with standard flange-type bolted fixing of Class a80-1

1.2.1 In addition, coupling balls 80 of Class a80-1 shall have the following principal dimensions:

Table 1: Dimensions standard flange-type bolted fixing

Subclass	a [mm]	b [mm]	c [mm]	D [mm]	E [mm]
a80-1.3	120	55	15	155	90
a80-1.4	140	80	17	180	120
a80-1.5	160	100	21	200	140

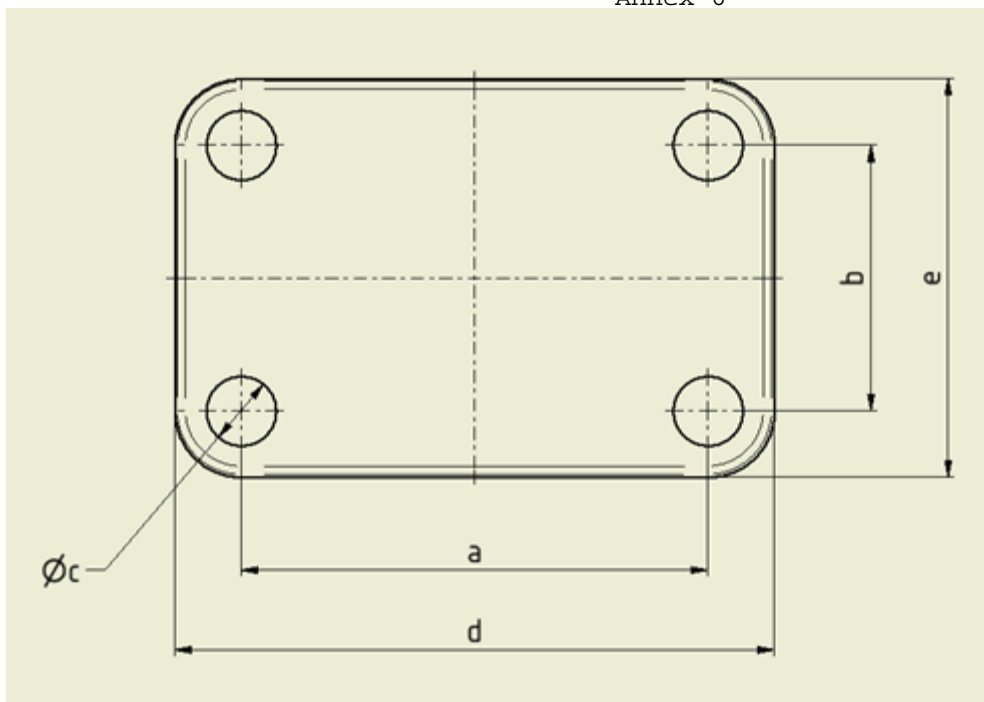

Figure 4 - Dimensions of standard flange

- 1.2.2 The flange may also be mounted so that it is rotated by an angle of 90° to the visual representation if this installation position was considered when performing the tests specified in annex 6 and is described in the installation and operating instructions.
- 1.3 Coupling balls 80 with latching rail plate (coupling mount) of Class a80-2
2. Coupling head 80
 - 2.1 General requirements for Coupling head 80
 - 2.1.1. All Coupling head 80 shall be designed so that they are able to satisfy the tests given in paragraph 3.2 of annex 6.
 - 2.1.2 Coupling head 80 of Class b shall conform to Figure 5 in external shape and external dimensions. The dimensions given in Figure 5 are identical to ISO 24347:2005.

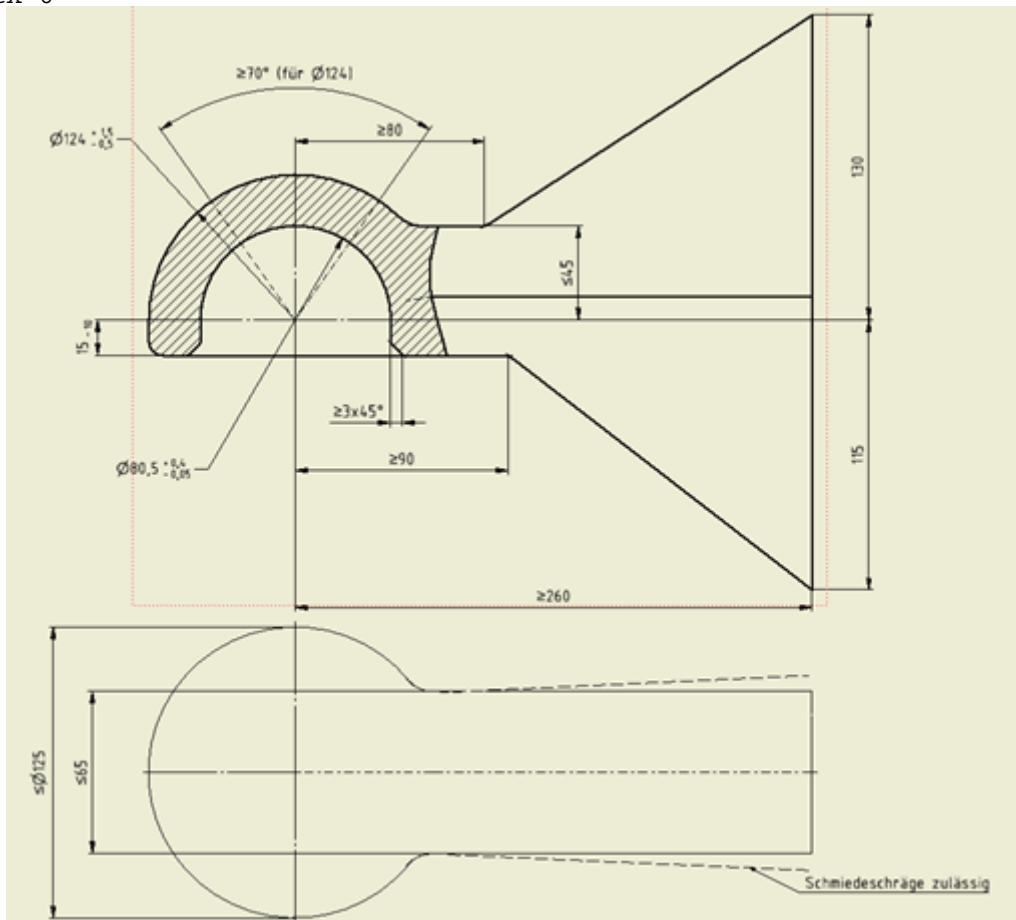

Figure 5 - Dimensions of standard ball-shaped scraper

2.2 Coupling head 80 with standard welding shank of Class b80-1

2.2.1 In addition, Coupling head 80 of Class b80-1 shall have the following dimensions:

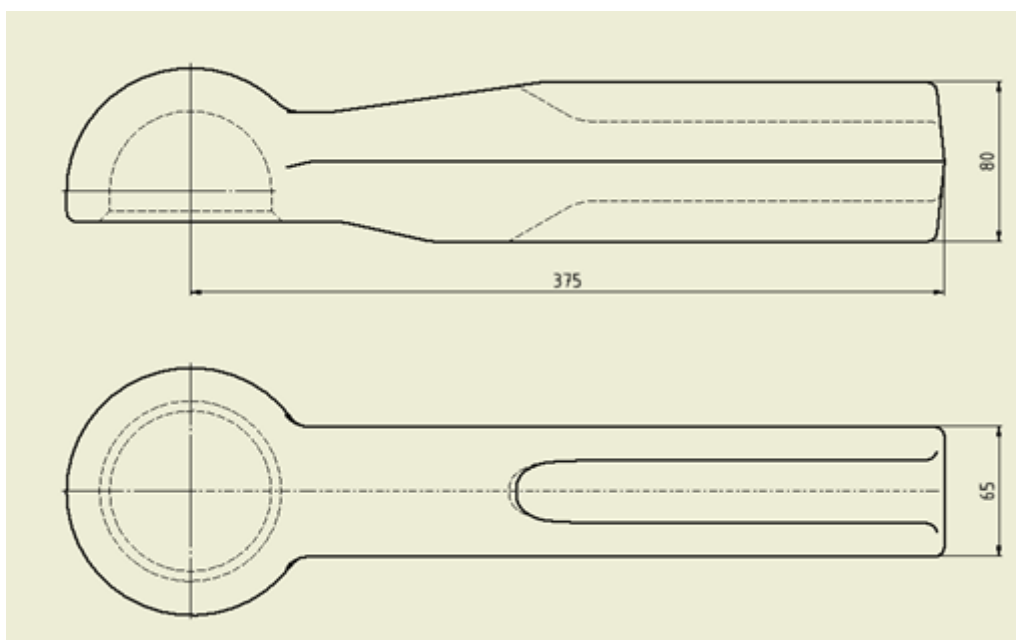

Figure 6 - Principal dimensions of standard Coupling head b80-1

2.3. Coupling head 80 with standard flange of Class b80-2

2.3.1 In addition, coupling head 80 of Class b80-2 shall have the

following principal dimensions:

Table 2: Dimensions of standard flange

Subclass	a [mm]	b [mm]	c [mm]	d [mm]	e [mm]	f [mm]
b80-2.1	100	-	110	17	154	154
b80-2.2	100	110	110	17	154	154
b80-2.3	130	130	130	21	205	195
b80-2.4	145	145	145	21	205	195
b80-2.5	145	160	145	21	205	195

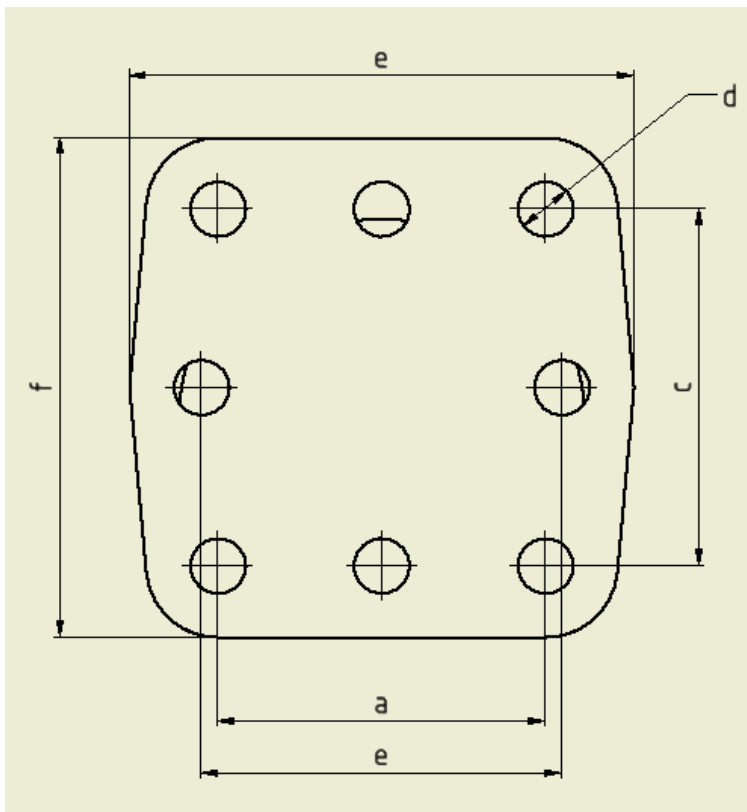

Figure 7 - Dimensions of standard flange ("e" on the bottom to be "b", include +/- 0,5 for a, b, and c and + 20 /-10 for e and f; applies to all Figures containing flanges))

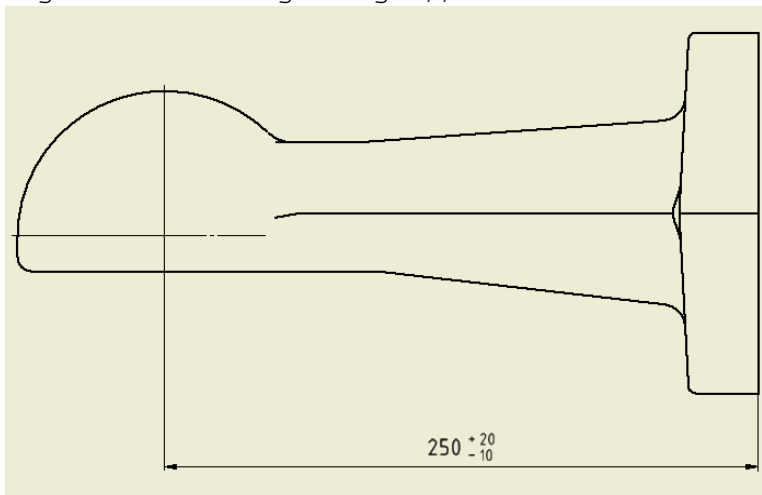

Figure 8 - Principal dimensions of standard Coupling head b80-2 ((Align "250" with Fig 5))

2.4. Coupling head 80 with standard horizontal flange of Class b80-3

2.4.1. In addition, Coupling head 80 of Class b80-3 shall have the following dimensions:

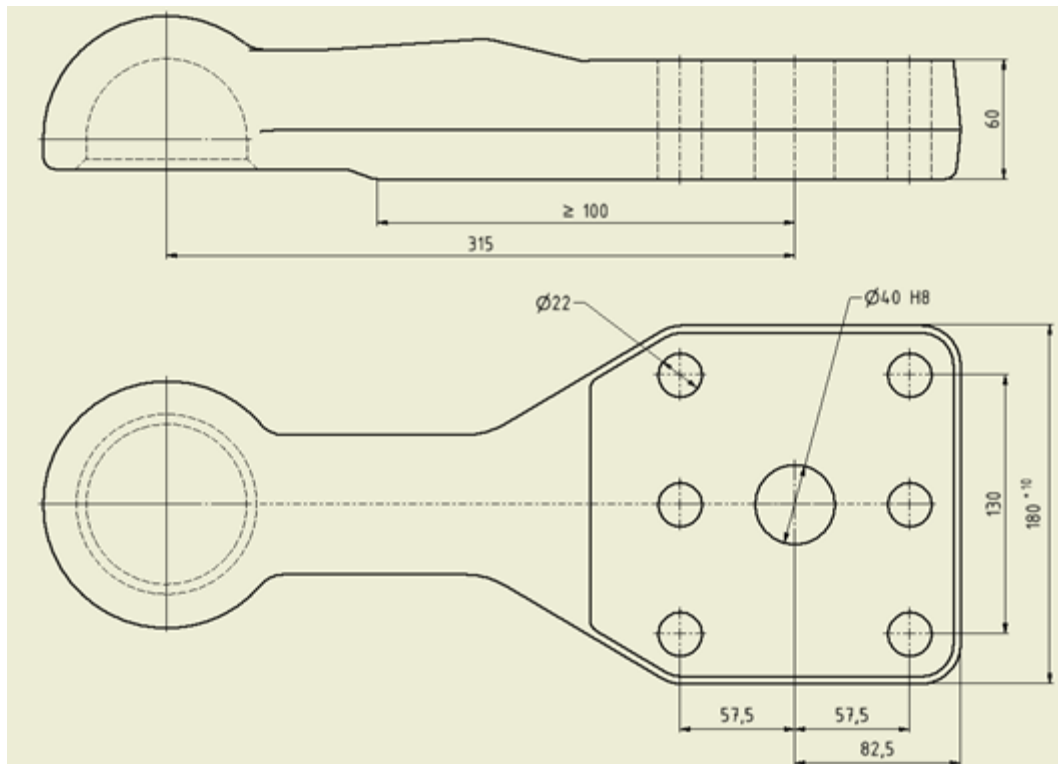

Figure 9 - Principal dimensions of standard Coupling head b80-3

3 Clevis-type couplings

3.1 General requirements for clevis-type couplings

3.1.1 All clevis-type couplings shall be designed so that they satisfy the tests prescribed in paragraph 3.3.1 of annex 6 and locking devices so that they satisfy the tests prescribed in paragraph 3.3.1.3 of annex 6.

3.1.2 Clevis-type couplings of Class c shall conform to Figures 10, 11 and 12 in external shape and external dimensions. For all classes, the maximum height of the jaw shall be constant over at least half the width of the jaw.

3.1.3 Requirements:

In the case of automatic couplings, the closed and locked position shall be clearly and conspicuously indicated externally after coupling by at least one control indicator.

3.1.4 Coupling and uncoupling of the coupling ring shall also be possible when the longitudinal axis of the coupling ring in relation to the centre line of the jaw:

- a) is rotated horizontally 50° to the right or left;
- b) is rotated vertically 6° up or down;
- c) is rotated axially 6° to the right or left.

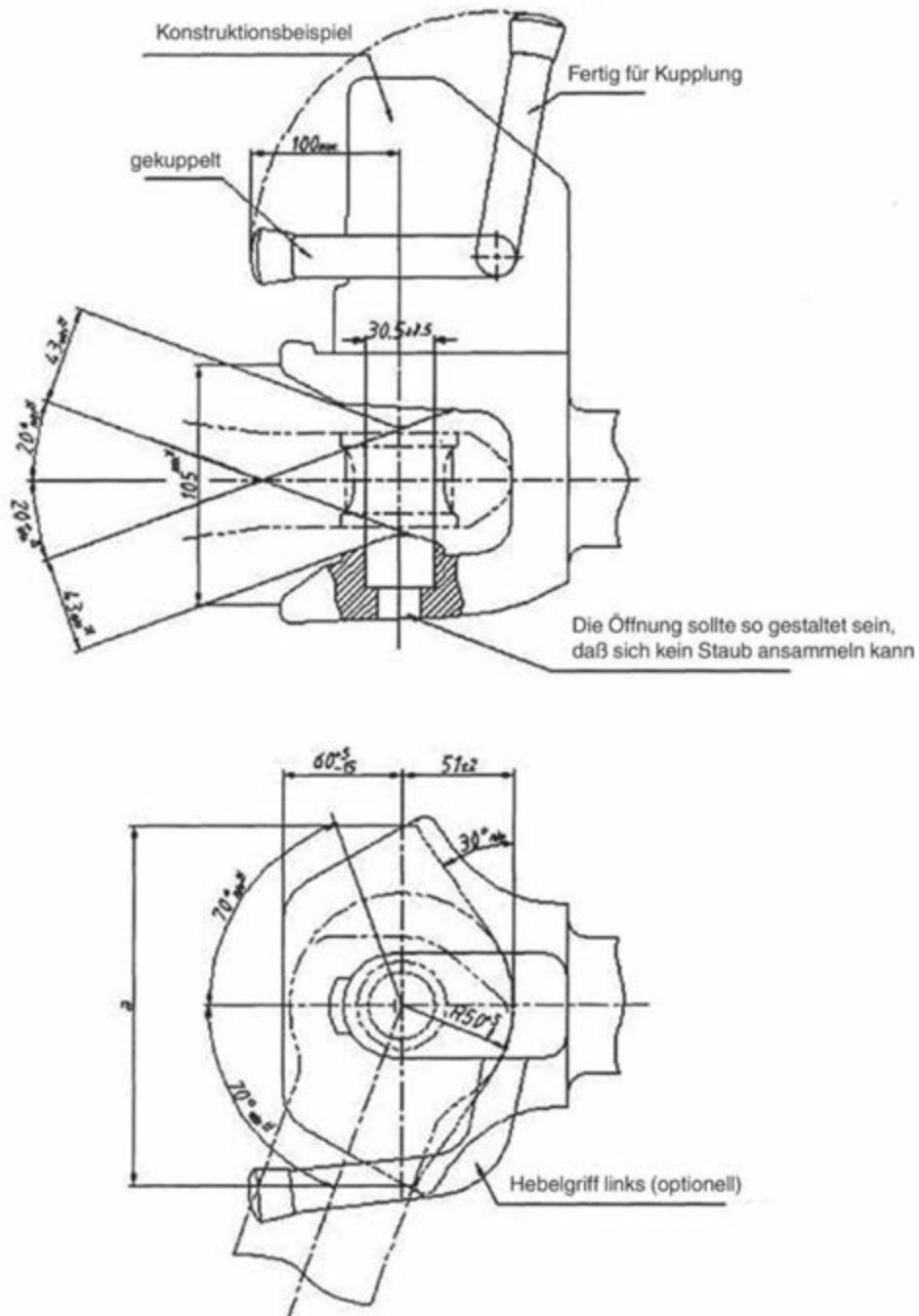

Figure 10 - Automatic trailer coupling with cylindrical pin ((redraw - English instead of German; change angle of pinch from 70° min to 60° min))

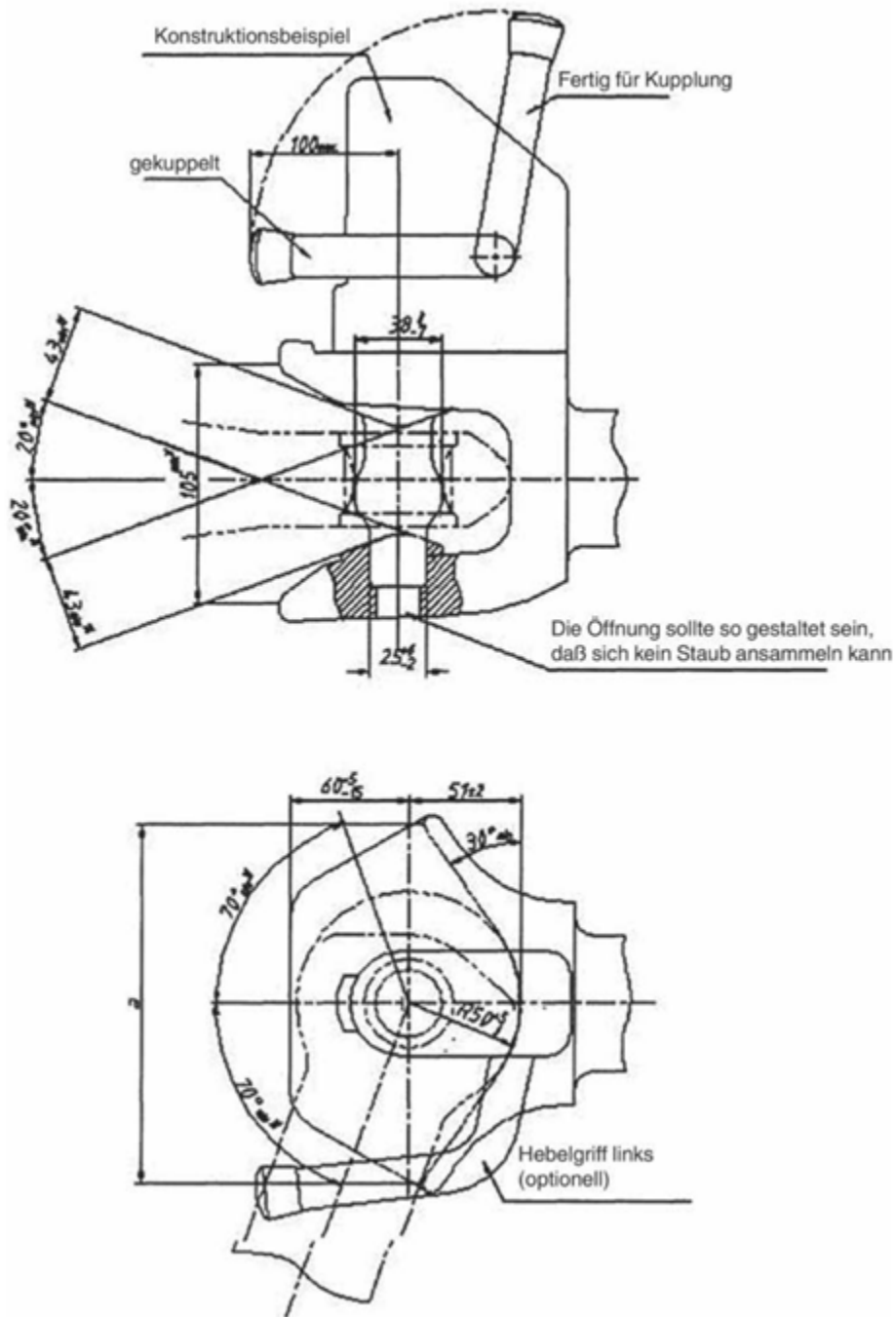

Figure 11 - Automatic coupling device with bulged pin ((see Fig. 10))

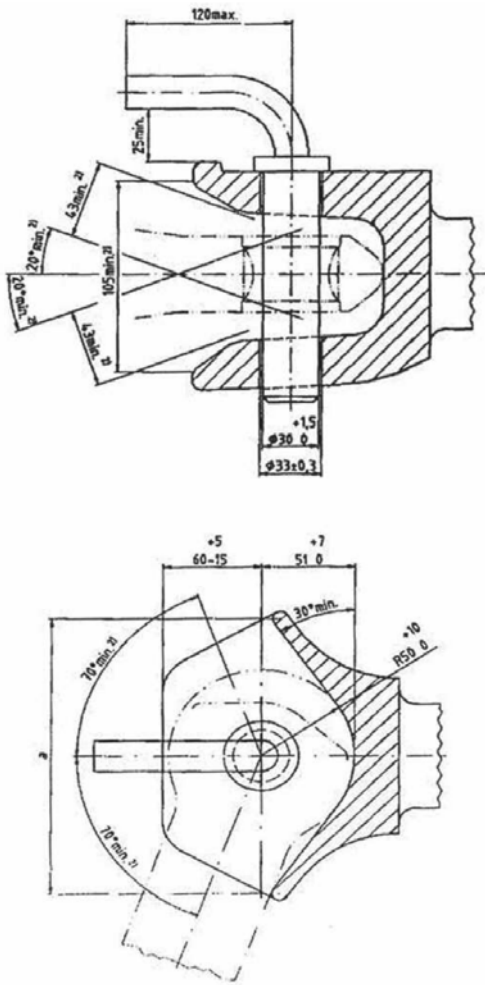

Figure 12 - Non-automatic trailer coupling with cylindrical pin ((see Fig. 10))

3.1.5 Clevis-type couplings shall have the following angles of articulation (see also Figures 10-13):

- Vertical axis: $\pm 60^\circ$
- Transverse axis: $\pm 20^\circ$
- Longitudinal axis: $\pm 20^\circ$

3.2 Clevis-type couplings with standard flange-type bolted fixing of Class c40-1

3.2.1 In addition, clevis-type couplings of Class c40-1 shall have the following principal dimensions:

Table 3: Dimension of standard flange-type bolted fixing

Subclass	a [mm]	b [mm]	c [mm]	D [mm]	e [mm]
c40-1.3	120	55	15	155	90
c40-1.4	140	80	17	180	120
c40-1.5	160	100	21	200	140

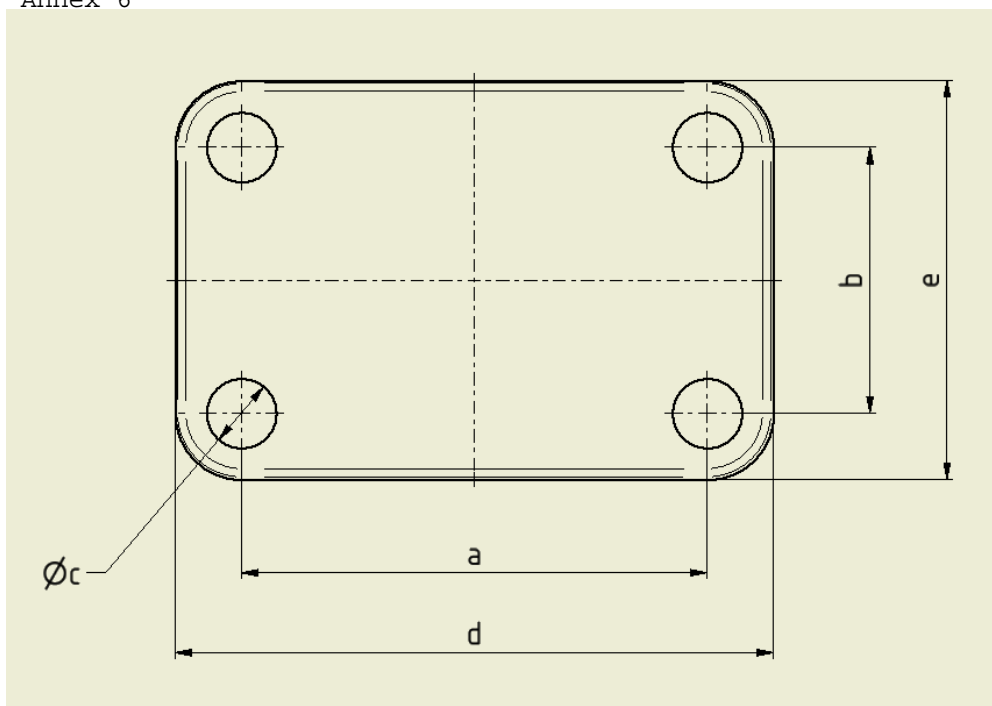

Figure 13 - Dimensions of standard flange

3.2.2 The flange may also be mounted so that it is rotated by an angle of 90° to the visual representation if this installation position was considered when performing the tests specified in annex 6 and is described in the installation and operating instructions.

3.3 Clevis-type couplings with latching rail plate (coupling mount/interior component) of Class c40-2

4 Drawbar eyes

4.1 Drawbar eyes d1-40

4.1.1 General requirements for Drawbar eyes d1-40

All Drawbar eyes of Class d1-40 shall be designed so that they are able to satisfy the tests given in paragraph 3.4 of annex 6. Drawbar eyes d1-40 may be equipped with or without socket.

Drawbar eyes shall conform to Figure 15 in the external shape and external dimensions of the ring. Dimensions of Figure 15 are identical to ISO 5692-2:2002.

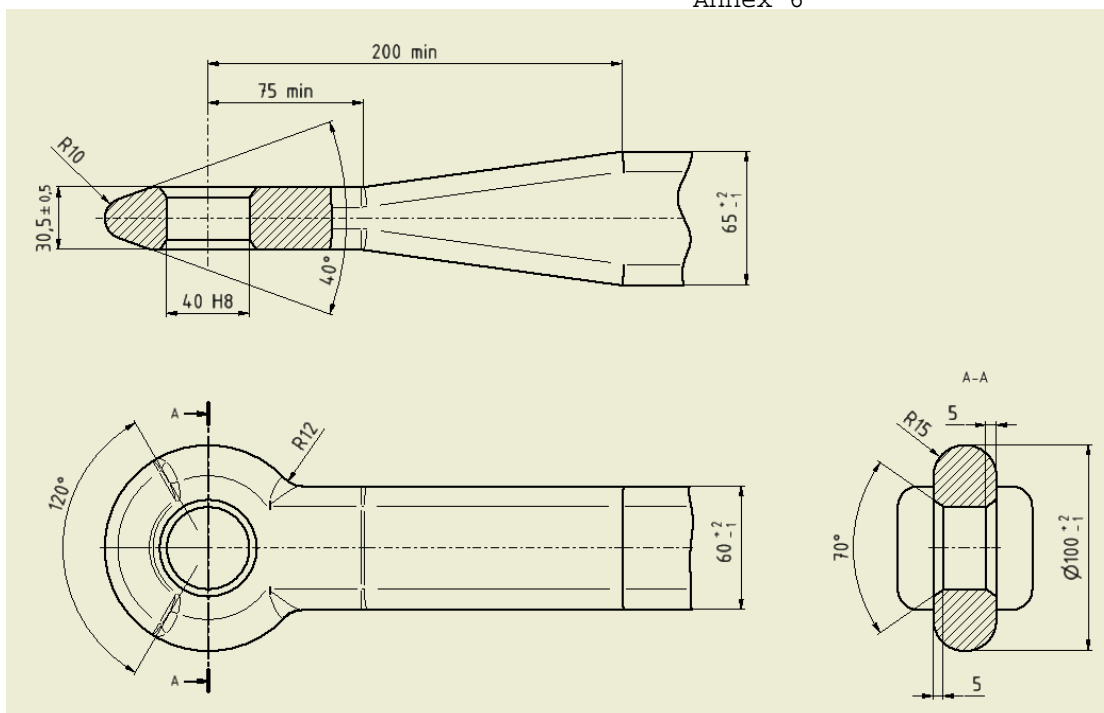

Figure 15 - Principal dimensions of standard Drawbar eyes d1-40 and d1-40-1 ((align with figure 1 from ISO 5692-2:2002

- 4.1.2 Drawbar eyes of Class d1-40-1 with standard welding shank
 Drawbar eyes of Class d1-40-1 shall conform to Figure 15 in dimensions 65 and 60 of the shank.
- 4.1.3 Drawbar eyes of Class d1-40-2 with standard straight shank
 Drawbar eyes of Class d1-40-2 shall conform to Figure 16 in the dimensions of the shank bearing.



Bild 2.

Figure 16 - Dimensions of standard coupling ring d1-40-2

4.1.4

Drawbar eyes of Class d1-40-3

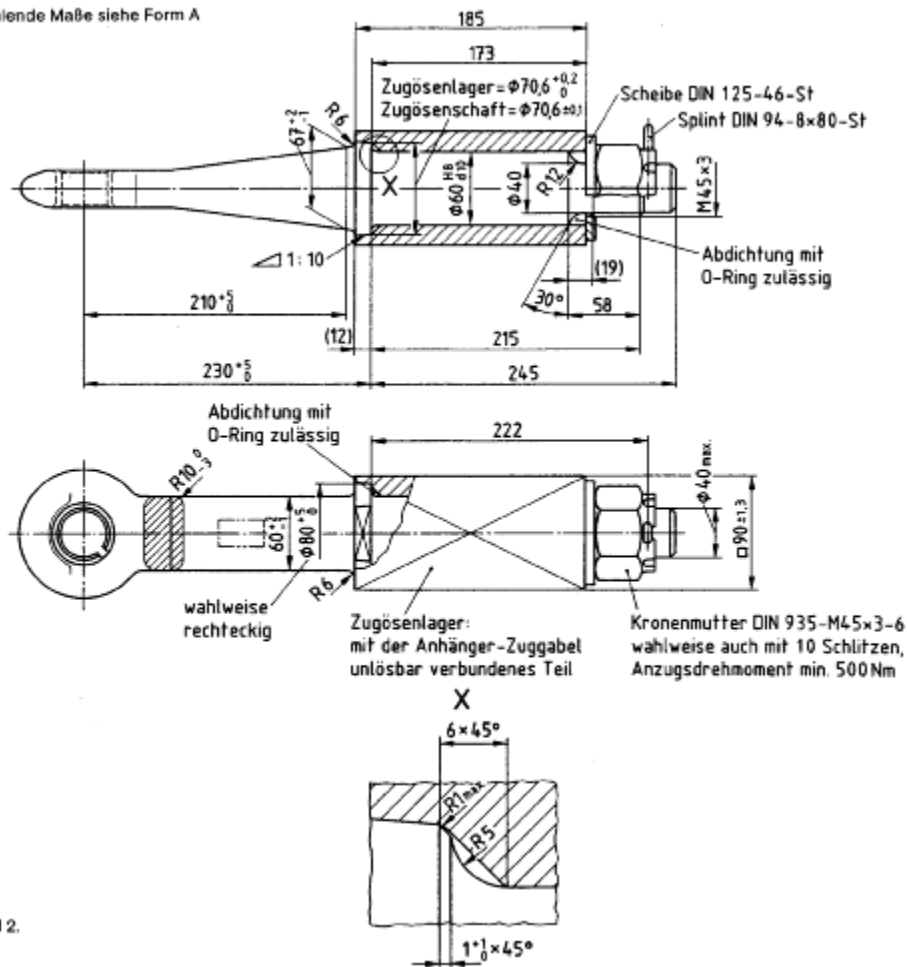
Drawbar eyes of Class d1-40-3 shall conform to Figure 17 in the dimensions of the flange.

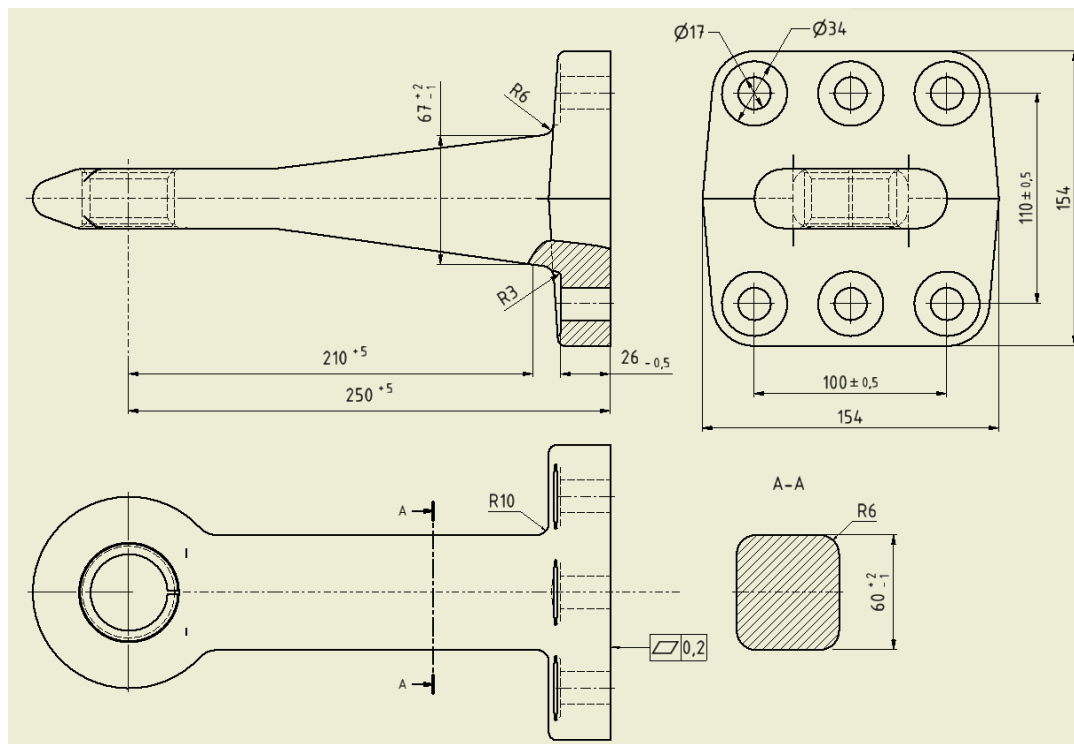

Figure 17 - Dimensions of standard coupling ring with standard flange d1-40-3

4.1.5

Socket 40

The sleeve must not be welded into the coupling ring. For Drawbar eyes d1-40-1 and d1-40-2, slotted or non-slotted sockets shall be used. For coupling ring d1-40-3, non-slotted sockets shall be used. Sockets shall be connected to the body of the coupling ring so that they cannot become loose during use. The design of the socket does not have to correspond to the visual representation, it must merely conform to the specified dimensions.

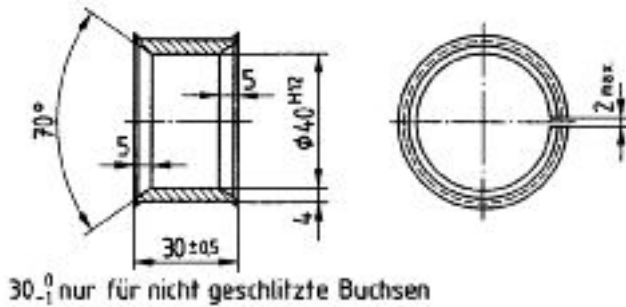

Figure 18 - Socket dimensions in the installed state

4.2

Drawbar eyes d2-40

4.2.1

General requirements for Drawbar eyes d2-40

All Drawbar eyes of Class d2-40 shall be designed so that they are able to satisfy the tests given in annex 9.

Drawbar eyes shall conform to Figure 19 in the external shape and external dimensions of the ring.

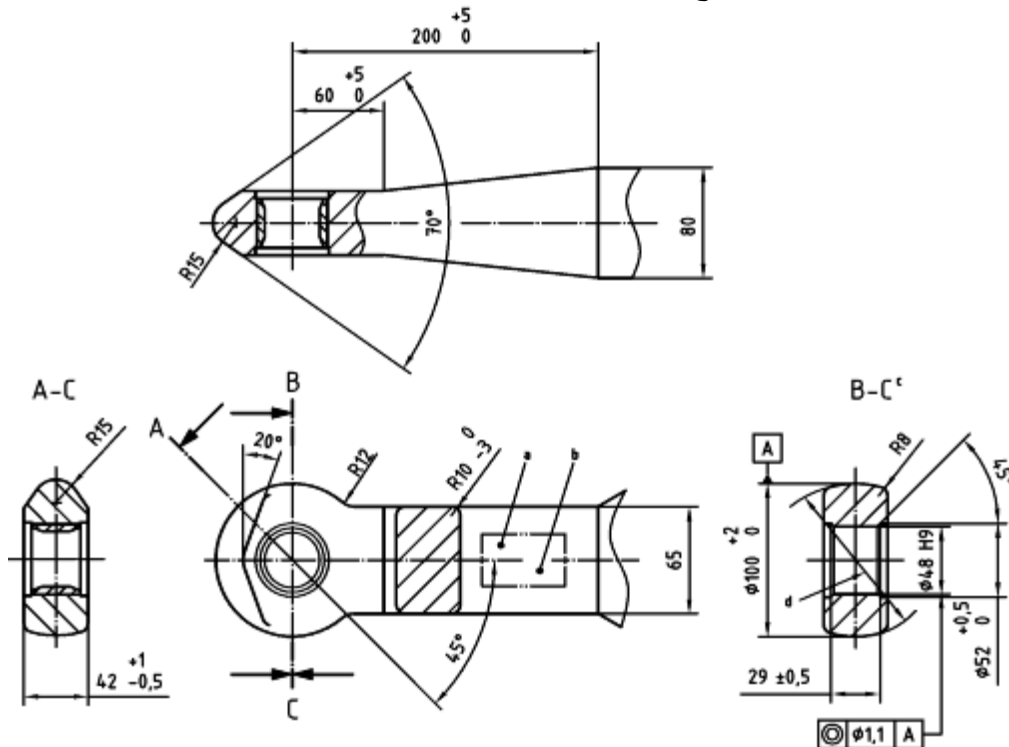

Figure 19 - Principal dimensions of standard coupling ring d2-40

4.2.2

Drawbar eyes of Class d2-40-1 with standard welding shank

In addition, Drawbar eyes of Class d2-40-1 shall conform to shank dimensions 65 and 80.

4.2.3

Drawbar eyes of Class d2-40-3

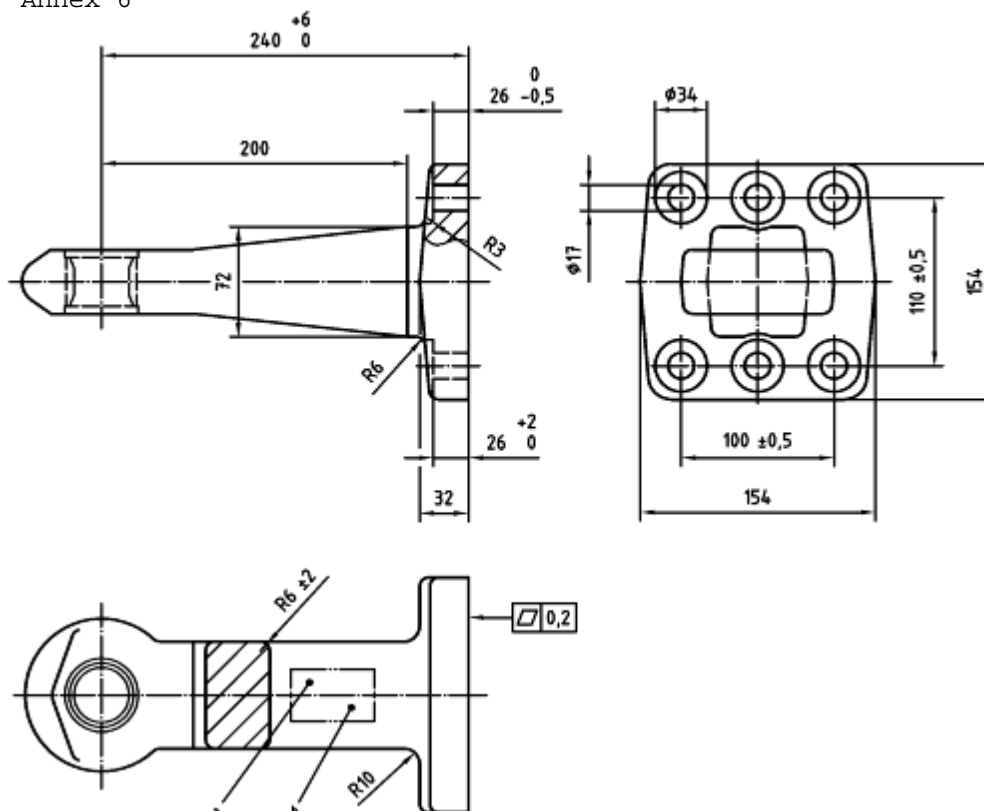

Figure 19 - Principal dimensions of standard coupling ring with standard flange d2-40-3

4.3 Drawbar eyes of Class d3-50-2

4.3.1 General requirements

All drawbar eyes of Class d3 shall be designed so that they are able to satisfy the tests given in annex 9.

Drawbar eyes of Class d3 shall conform to Figure xx in external shape and external dimensions. Dimensions of Figure 15 are identical to ISO 5692-1:2004.

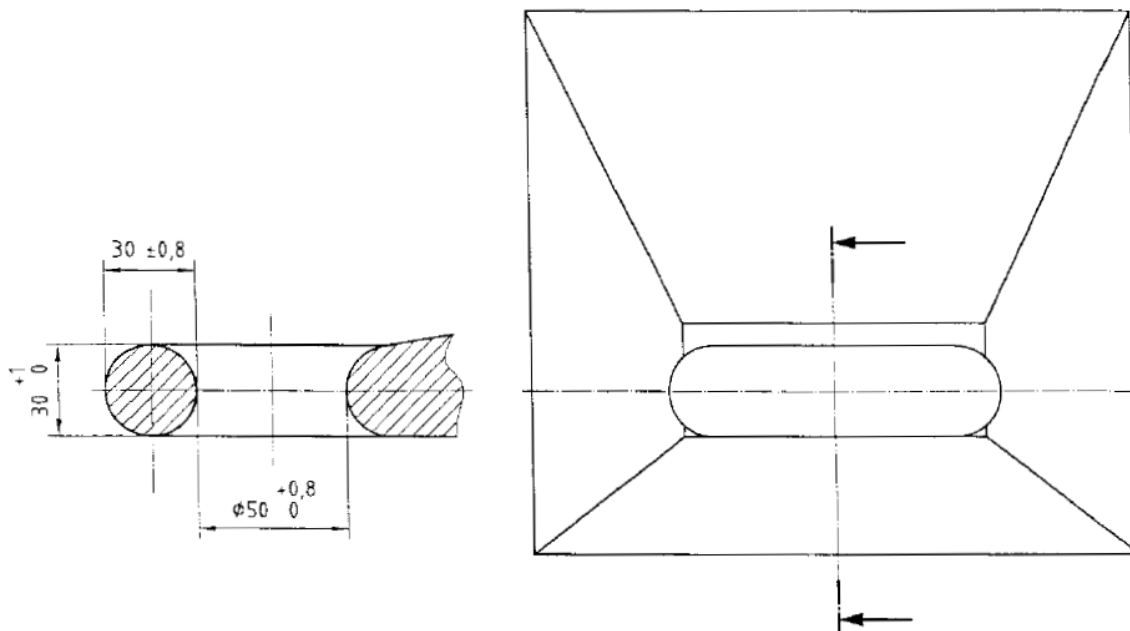

Figure 20 - Hitch ring 50

Figure 21 - Hitch ring 50 side view (similar to Figure 2 of ISO 5692-1:2004 and corresponding to Figure 5))

4.3.2 Drawbar eyes 50 with standard welding shank of Class d3-50-1

In addition, Drawbar eyes of Class d3-50-1 shall have the following dimensions:

((insert image))

Figure 22 -

4.3.3 Drawbar eyes 50 with standard flange of Class d3-50-2

In addition, Drawbar eyes of Class d3-50-2 shall have the following principal dimensions:

Table 4: Dimensions of standard flange

Subclass	a [mm]	b [mm]	c [mm]	d [mm]	e [mm]	F [mm]
d3-50-	100	-	110	17	154	154
d3-50-	100	110	110	17	154	154
d3-50-	130	130	130	21	205	195
d3-50-	145	145	145	21	205	195
d3-50-	145	160	145	21	205	195

4.4 Drawbar eyes of Class d4

4.4.1 General requirements

All Drawbar eyes of Class d4 shall be designed so that they are able to satisfy the tests given in annex 9.

Drawbar eyes of Class d4 shall conform to Figure xx in external shape and external dimensions.

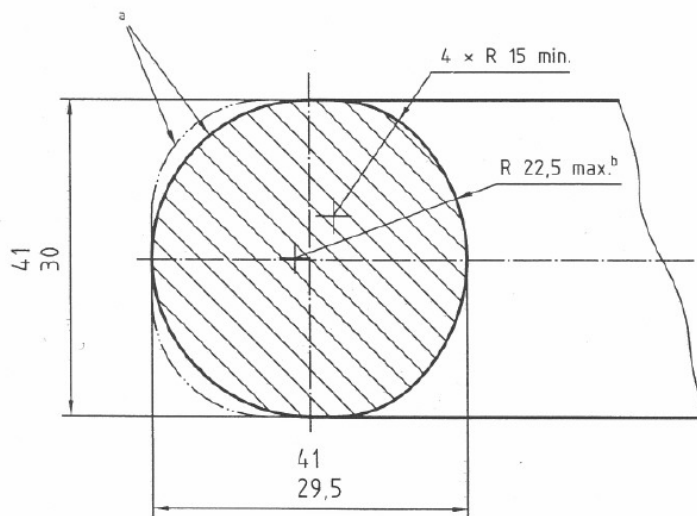

- ^a Alternative outer contour: outer radius 22.5 max. and 15 min. blend radius top and bottom, or min. top and bottom blend radius to flat outer surface.
- ^b Internal contour.

Figure 23 - ((Title))

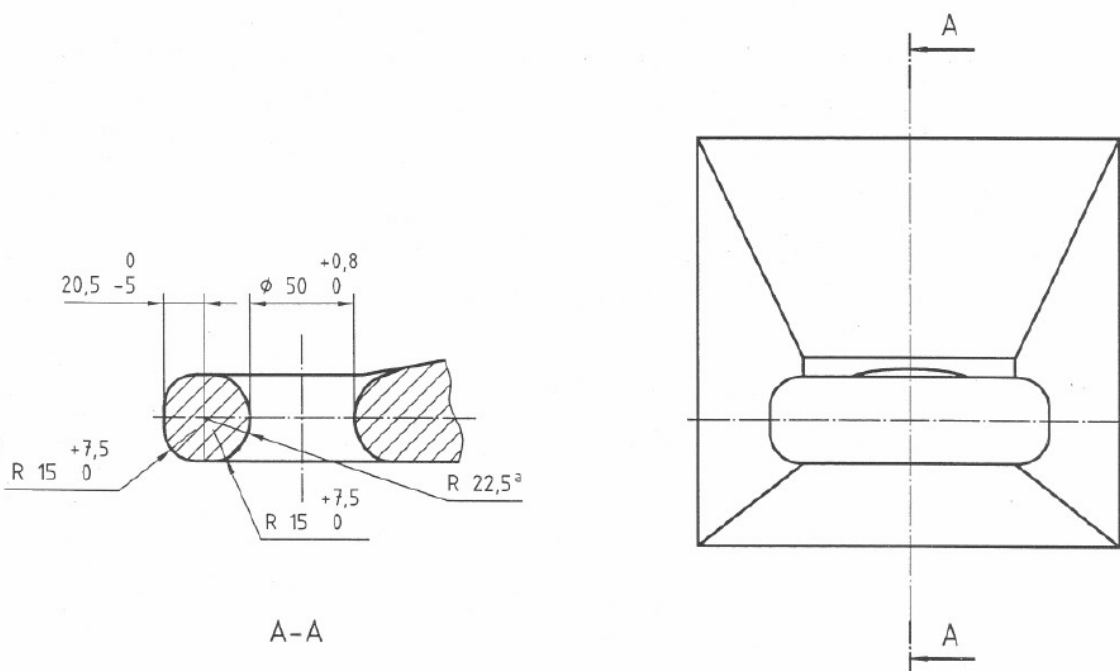

- ^a Internal contour.

Figure 24 - ((Title))

Figure 25 - ((corresponding to Figure 3 ISO 20019:2001))

4.4.2 Drawbar eyes 50 with standard welding shank of Class d4-50-1

In addition, Drawbar eyes of Class d4-50-1 shall have the following dimensions:

Figure 25 - ((insert image))

4.4.3 Drawbar eyes 50 with standard flange of Class d4-50-2

In addition, Drawbar eyes of Class d4-50-2 shall have the

following principal dimensions:

Table 5: Dimensions of standard flange

Subclass	a [mm]	b [mm]	c [mm]	d [mm]	e [mm]	F [mm]
d4-50-	100	-	110	17	154	154
d4-50-	100	110	110	17	154	154
d4-50-	130	130	130	21	205	195
d4-50-	145	145	145	21	205	195
d4-50-	145	160	145	21	205	195

5. Drawbars
 - 5.1. Drawbars of Class e shall satisfy the tests given in paragraph 3.5 of annex 6.
 - 5.2. In order to provide a connection to the towing vehicle, the drawbars can be fitted with either Coupling head or Drawbar eyes of Classes b, d or s. Coupling head and Drawbar eyes can be attached by screwing, bolting or welding.
 - 5.3. Height adjusting devices for hinged drawbars
 - 5.3.1. Hinged drawbars shall be fitted with devices for adjusting the drawbar to the height of the coupling device or jaw. These devices shall be designed so that the drawbar can be adjusted by one person without tools or any other aids.
 - 5.3.2. Height adjusting devices shall be able to adjust the Drawbar eyes or Coupling head 80 from the horizontal above the ground at least 300 mm upwards and downwards. Within this range the drawbar shall be adjustable steplessly, or in maximum steps of 50 mm measured at the coupling ring or Coupling head.
 - 5.3.3. Height adjusting devices shall not interfere with the easy movement of the drawbar after coupling.
 - 5.4. The height adjusting devices shall not interfere with the action of any inertia, overrun type, brake.
 - 5.5. In the case of drawbars combined with inertia, overrun, brakes, the distance between the centre of the coupling ring and the end of the free shank of the coupling ring shall not be less than 200 mm in the brake application position. With the shank of the coupling ring fully inserted the distance shall not be less than 150 mm.
 - 5.6. Drawbars for use on rigid drawbar trailers shall possess at least

half the moment of resistance against lateral forces as against vertical forces.

- 5.7 Drawbars as defined in annex 5, paragraphs 2 and 4 shall be designed so that within the coupling point height specified by the manufacturer they have a maximum angle to the horizontal of $\pm 3^\circ$.
6. Towing brackets
- 6.1. Towing brackets of Class f shall satisfy the tests given in paragraph 3.6 of annex 6.
- 6.2. Towing brackets shall generally be installed on the vehicle's structure and are used to mount coupling devices of Classes a, c, g, h, q or s and any other mounted devices. Other mounted devices may include positive steering components, shank bearings, etc. which transmit additional forces to the towing bracket.
- 6.3. Towing brackets can be designed as quick height-adjustable (qha), pin height-adjustable (pha) bracket or as frame without height adjustment.
7. Hitch hooks and keeper plates
- 7.4 General requirements for hitch hooks

All hitch hooks of class g and keeper plates shall be designed such that hitch hooks satisfy the tests given in annex 9 and keeper plates satisfy the tests given in annex 9.

Hitch hooks of Class g shall conform to Figure 27 in external shape and external dimensions. The position of the keeper plate is shown in Figure 28.

Dimensions in millimetres

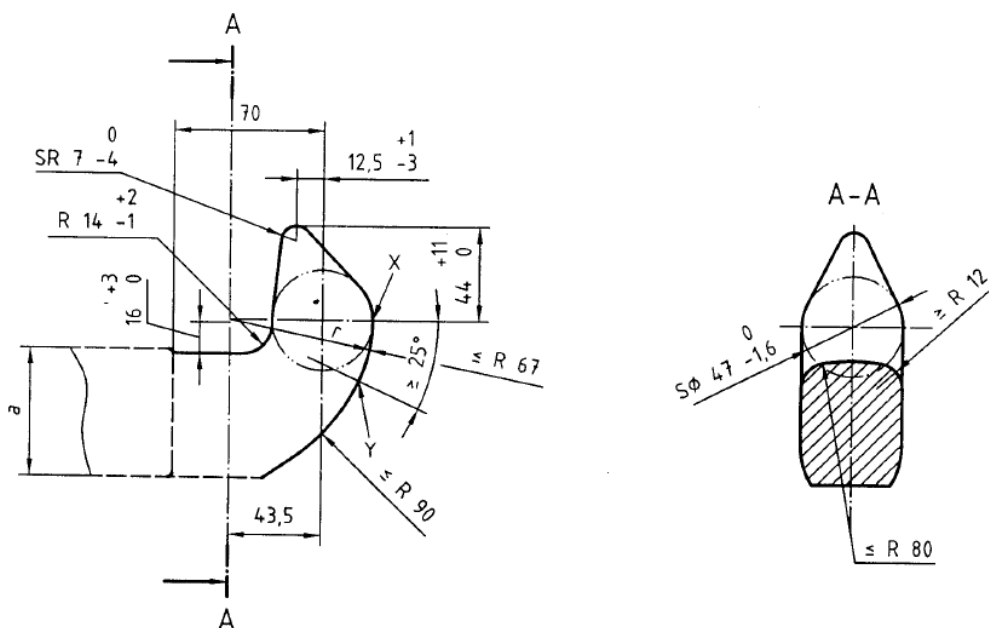

a Not controlled.

Figure 27 - Principal dimensions of hitch hook ((add Fig. 2 of ISO 6489-1:2001))

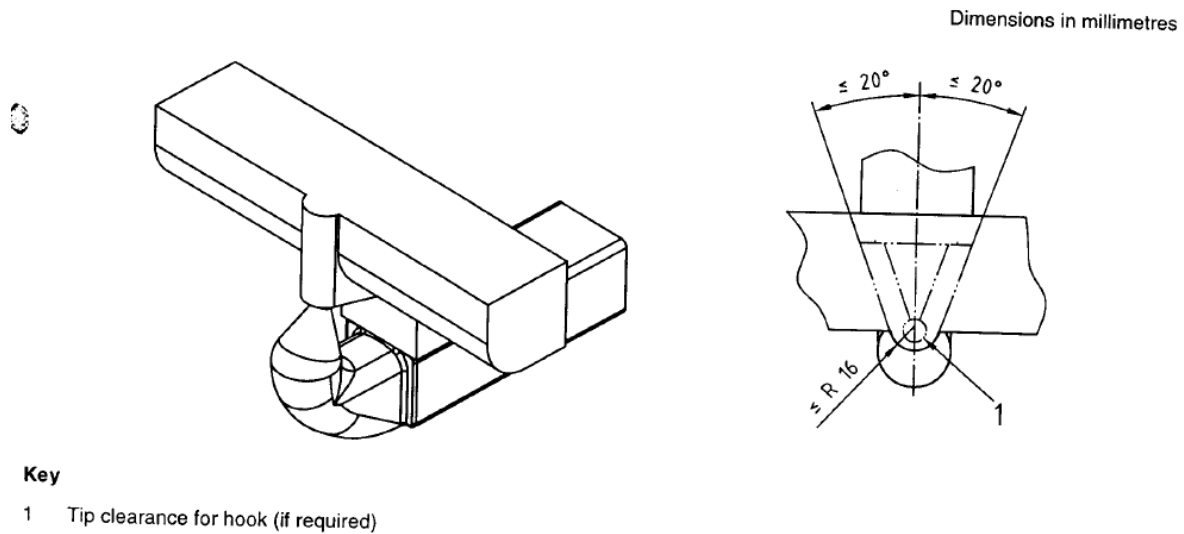

Figure 28 - Position of the keeper plate

The hitch hook shall permit angles of articulation in accordance with 1.1.3.

8. Piton-type couplings and keeper plates

8.1. General requirements for piton-type couplings

All piton-type couplings of class h and keeper plates shall be designed such that piton-type couplings satisfy the tests given in of annex 9 and keeper plates satisfy the tests given in annex 9.

Piton-type couplings of Class h shall conform to Figure 29 in external shape and external dimensions. The position of the keeper plate is shown in Figure 30.

Dimensions in millimetres

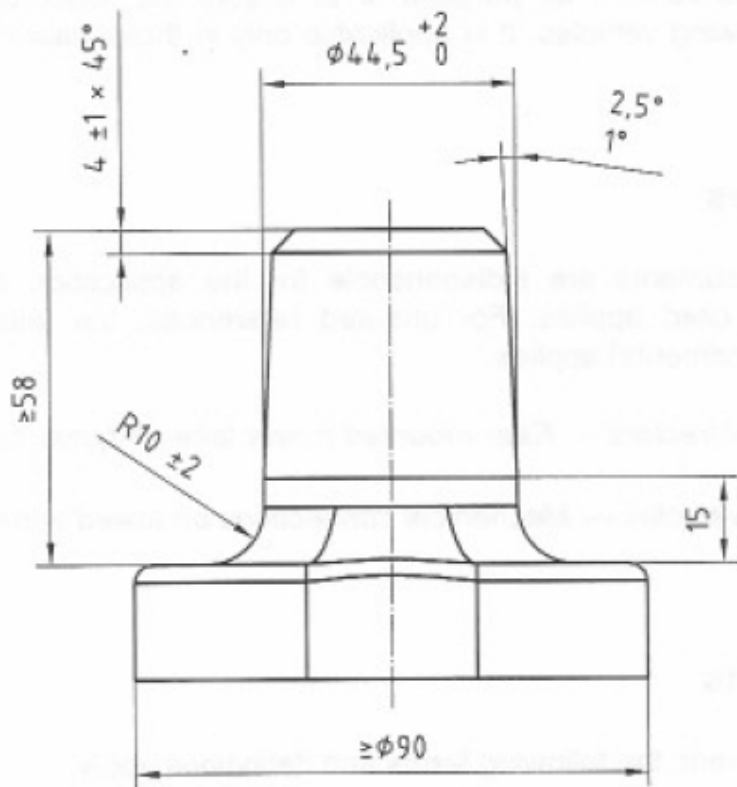

Figure 29 - Principal dimensions of the piton-type coupling

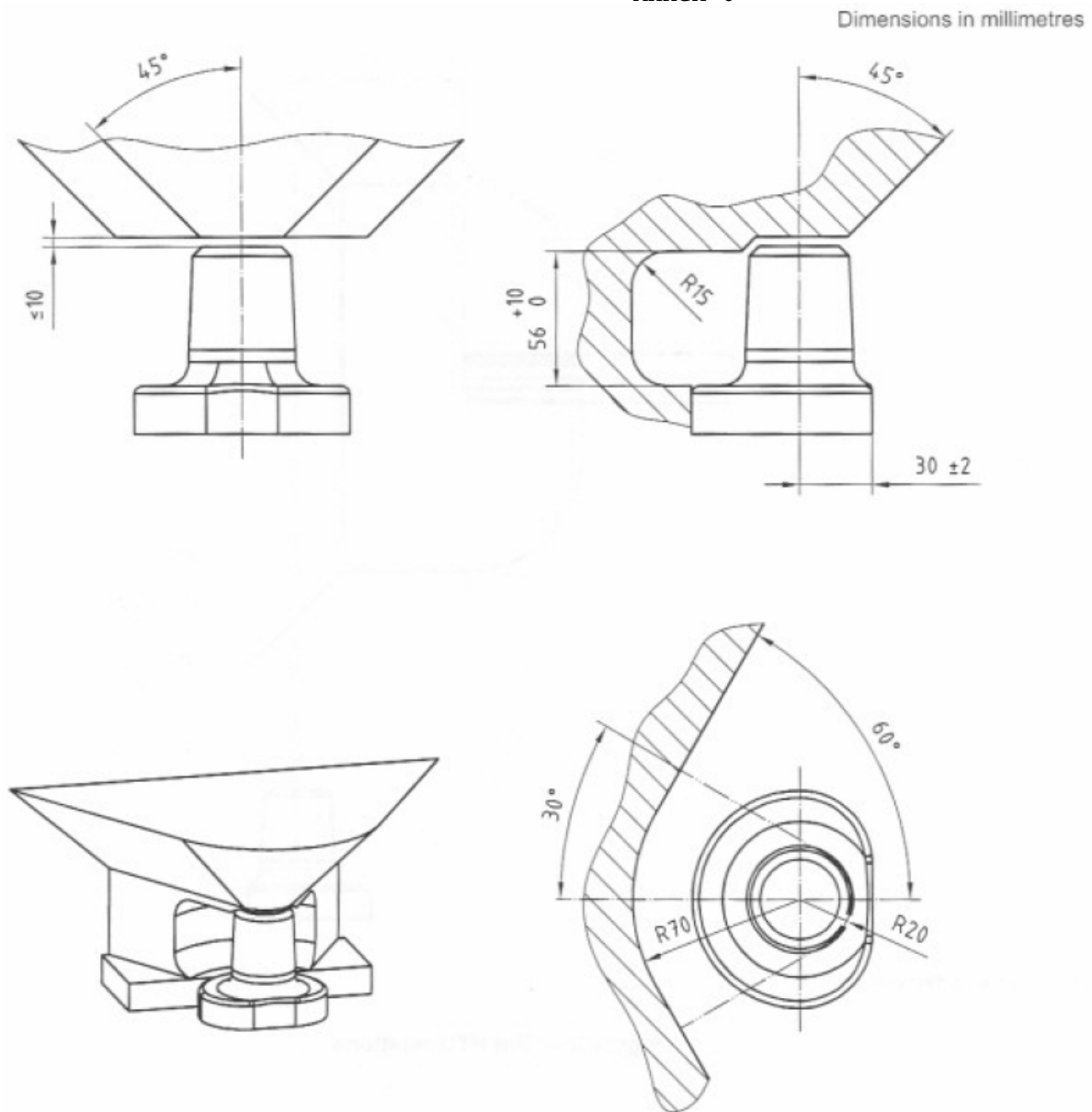

Figure 2 — Dimensions of keeper limiting surface (maximum metal)

Figure 30 - Position of the keeper plate

The piton-type coupling shall permit angles of articulation in accordance with 1.1.3.

9. Coupling devices of Class s and p

For coupling devices of Class s and p, the relevant requirements in annexes 5 and 6 for the closest standard or non-standard device or component shall be used.

10. Assignment of mechanical coupling devices of towing vehicles or self-propelled machines and towed vehicles

Table 6: Assignment of mechanical coupling devices of towing vehicles or self-propelled machines and towed vehicles

Coupling device on the towing vehicle	Coupling device on the towed vehicle
Class a	Class b
Class c	Class d1
Class c	Class d2
Class g	Class d3
Class g	Class d4
Class h	Class d3
Class i-18	Class r1
Class i-30	Class d1, d2 or r2
Class i-38	Class d3, d4 or r3
Class q1	Class r1
Class q2	Class r2
Class q3	Class r3

Annex 6

TESTING OF MECHANICAL COUPLING DEVICES OR COMPONENTS FOR VEHICLES OF CATEGORIES T, R AND S

1. General testing requirements
 - 1.1 Samples of coupling devices shall be tested for both strength and function. With coupling devices the strength shall be verified by a dynamic test. In certain cases additional static tests may be necessary. Instead of the dynamic test, mechanical couplings of classes i, q and r intended to be mounted to agricultural vehicles with a maximum design speed not exceeding 40 km/h may be tested according to 3.3.3.2 of this annex (static test). In addition, the type approval authority or technical service may waive a dynamic or static test if the simple design of a component makes a theoretical check possible. Theoretical checks may also be carried out to determine worst case conditions. In all cases, theoretical checks shall ensure the same quality of results as with dynamic or static testing. In cases of doubt it is the results of physical testing that are overriding.
 - 1.2 The dynamic test shall be performed with approximately sinusoidal load (alternating and/or pulsating) with a number of stress cycles appropriate to the material. No cracks or fractures shall occur.
 - 1.3 Only slight permanent deformation is permitted with the static tests prescribed. Unless stated otherwise the permanent (plastic) deformation after releasing shall not be more than 10 per cent of the maximum deformation measured during the test.
 - 1.4 The loading assumptions in the dynamic tests are based on the horizontal force component in the longitudinal axis of the vehicle and the vertical force component. Horizontal force components transverse to the longitudinal axis of the vehicle, and moments, are not taken into account provided they are of only minor significance.
If the design of the coupling device or its attachment to the vehicle or the attachment of additional systems (such as equipment drives, force compensators, positive steering systems, etc.) generates additional forces or moments, these shall be taken into account during the tests. Additional tests may also be required by the type approval authority or technical service.
The horizontal force component in the longitudinal axis of the vehicle is represented by a theoretically determined reference force, the D or D_c value. The vertical force component, where applicable, is represented by the static vertical bearing load, S , at the point of coupling and the assumed vertical force component, V .
 - 1.5 The characteristic values D , D_c , S and v_{max} , on which the tests are based and which are defined in paragraph 2.10 of this Regulation, shall be taken from the manufacturer's information given in the application for type approval - see communication form shown in annex 1.
 - 1.6 Any positive locking device, which is retained in position by spring force, shall remain in its secured position when subjected to a force applied in the least favourable direction and equivalent to three times the mass of the locking mechanism.

Otherwise, several coupling device positions shall be tested.

2. Test procedures
 - 2.1 For the dynamic tests and static tests, the sample shall be placed in a suitable rig with a means of force application, such that it is not subjected to any additional forces or moments apart from the specified

test force. In the case of alternating tests, the direction of force application shall not deviate by more than $\pm 1^\circ$ from the specified direction. In the case of pulsating and static tests, the angle shall be set for the maximum test force. This will normally require a joint at the point of force application (for example at the point of coupling) and a second joint a given distance away.

- 2.2 The test frequency shall not exceed 35 Hz. The selected frequency shall be well separated from resonance frequencies of the test set up including the tested device. With asynchronous testing the frequencies of the two force components shall be between approximately 1 per cent and a maximum of 3 per cent apart. For coupling devices made from steel the number of stress cycles is 2×10^6 . For devices made from materials other than steel a higher number of cycles may be necessary. The dye-penetration method of crack testing or an equivalent method shall be used to determine any cracking during test.
- 2.3 With pulsating tests, the test force varies between the maximum test force and a minimum test force, which may not be greater than 5 per cent of the maximum test force unless otherwise stated in the specific testing procedure.
- 2.4 With static tests the test force shall be applied smoothly and quickly and be maintained for at least 60 seconds.
- 2.5 The coupling devices or components on test should normally be mounted as rigidly as possible on a test rig in the position in which they will be used on the vehicle. The fixing devices should be those specified by the manufacturer or applicant and should be those intended for the attachment of the coupling device or component to the vehicle and/or shall have identical mechanical characteristics.
- 2.6 Coupling devices or components shall be tested in the form used on the road. However, at the discretion of the manufacturer, and in agreement with the technical service, flexible components may be clamped if this is necessary for the test procedure and if this will not have any unrealistic influence on the test result. Flexible components which are overheated during these accelerated test procedures may be replaced during the test. The test loads may be applied by means of special slack-free devices.
3. Specific testing requirements
 - 3.1 Coupling balls 80 (Class a)
 - 3.1.1 The basic test is a dynamic pulsating endurance test with resultant test force. Alternatively, a two-component synchronous dynamic endurance test is also permissible. The test sample comprises the coupling ball and the mountings necessary for attaching the assembly to the vehicle. The coupling ball shall be rigidly mounted to a test rig, capable of producing an alternating or pulsating force, in the actual position in which it is intended for use.
 - 3.1.2 A suitable Coupling head 80 shall be used as a means of force application. The sample shall be mounted on the test rig with the coupling elements applied for and arranged such that its relative position corresponds to that of the intended use. The sample shall not be subjected to any additional forces or moments apart from the test force. The test force shall be applied along a line of action through the point of coupling, directed at a resultant angle derived from the horizontal and vertical loading assumptions.
 - 3.1.3 Loading assumptions

Dynamic pulsating endurance test with resultant test force:

$$F_{res} = \sqrt{F_h^2 + F_s^2} \quad (\text{kN})$$

$$\alpha = \arctan \frac{F_s}{F_h}$$

within the range for tensile or compressive pulsating stresses (whichever is the greater)

Where

Horizontal load (kN):

$$F_h = 1.0 \cdot D_c$$

$$F_h = 1.0 \cdot D \text{ for full trailers}$$

Vertical load (kN)

$$F_s = g \cdot S + 0,3 \cdot V$$

$$V = a \cdot C \cdot (x/l)^2$$

$$a = 1,8 \text{ m/s}^2$$

$$x/l = 1,2$$

3.2 Coupling head 80 (Class b)

3.2.1 The basic test is a dynamic endurance test in which an alternating or pulsating test force is applied. Alternatively, a two-component synchronous dynamic endurance test is also permissible.

3.2.2 The dynamic test shall be performed using a separate assembly with a coupling ball 80 of an equivalent or higher strength.

The sample shall be mounted on the test rig with the coupling elements applied for and arranged such that its relative position corresponds to that of the intended use.

The sample shall not be subjected to any additional forces or moments apart from the test force.

The test force shall be applied along a line of action through the point of coupling, directed at a resultant angle derived from the horizontal and vertical loading assumptions.

3.2.3 Loading assumptions

As in 3.1.3 of this annex (coupling balls 80)

3.3. Drawbar couplings

3.3.1 Clevis-type couplings (Class c)

A dynamic endurance test shall be carried out on a sample. The coupling device shall be equipped with all the fixings needed to attach it to the vehicle.

3.3.1.1 for rigid drawbar trailers.

Dynamic pulsating endurance test within the range for pulsating tensile stresses with resultant test force (direction of pull rearwards and down)

$$F_{res} = \sqrt{F_h^2 + F_s^2}$$

$$\alpha = \arctan \frac{F_s}{F_h}$$

Where:

Horizontal load (kN):

$$F_h = 1.0 \cdot D_c$$

$$F_h = 1.0 \cdot D \text{ for full trailers}$$

Vertical load (kN)

$$F_s = g \cdot S + 0,3 \cdot V$$

$$V = a \cdot C \cdot (x/l)^2$$

$$a = 1,8 \text{ m/s}^2$$

$$x/l = 1,2$$

Special case: For articulated drawbar trailers, $F_s = 0$

Alternatively:

Asynchronous dynamic endurance test (2-component) with test forces as defined in R55 annex 6, number 3.3 (as last amended)

3.3.1.2 Clevis-type couplings on trailers:

Loading assumptions taking into account the D value

$$D = g \cdot \frac{R_1 \cdot R_2}{R_1 + R_2} \quad \text{is used.}$$

R_1 and R_2 as specified by the manufacturer ($R_2 \leq R_1$) or
Dynamic endurance tests as in 3.3.1.2.

3.3.1.3 Static tests on locking device for coupling pin

With clevis-type couplings with non-cylindrical pins, it is also necessary to test the closure and any locking devices by means of a static force of 0.25 D acting in the direction of opening.

A test force of 0.1 D is sufficient in the case of cylindrical coupling pins.

This force shall be raised to the above value smoothly and quickly and be maintained for 10 seconds.

The test shall not cause the closure to open and it shall not cause any damage.

3.3.2 Hitch hooks (Class g)

As in 3.1.3 of this annex.

3.3.3 Tractor drawbars (Class i)

3.3.3.1 Either as in 3.1.3 of this annex or a static test instead of the dynamic test as described in 3.1.3 if the drawbar is intended to be mounted to agricultural vehicles with a maximum design speed not exceeding 40 km/h.

3.3.3.2 Static Test Method

3.3.3.2.1. Test specifications

3.3.3.2.1.1 General

3.3.3.2.1.1.1 Subject to a check on its construction characteristics, the mechanical coupling shall undergo static tests in accordance with the requirements of points 3.3.3.2.1.2, 3.3.3.2.1.3 and 3.3.3.2.1.4.

3.3.3.2.1.2 Test preparation

The tests shall be carried out on a special machine, with the mechanical coupling and any structure coupling it to the body of the tractor attached to a rigid structure by means of the same components used to mount it on the tractor.

3.3.3.2.1.3 Test instruments

The instruments used to record loads applied and movements shall have the following degree of accuracy:

- loads applied ± 50 daN,
- movements $\pm 0,01$ mm.

3.3.3.2.1.4 Test procedure

3.3.3.2.1.4.1 The coupling device shall first be subjected to a pre-traction load which does not exceed 15 % of the traction test load defined in point 3.3.3.2.1.4.2.

3.3.3.2.1.4.1.1 The operation described in point 3.3.3.2.1.4.1 shall be repeated at least twice, starting with a zero load, which is gradually increased until the value prescribed in point 3.3.3.2.1.4.1 is reached, and then decreased to 500 daN; the settling load shall be maintained for at least 60 seconds.

3.3.3.2.1.4.2 The data recorded for plotting the load/deformation curve under traction, or the graph of that curve provided by the printer linked to the traction machine, shall be based on the application of increasing loads only, starting from 500 daN, in relation to the reference centre of the coupling device.

There shall be no breaks for values up to and including the traction test load which is established as 1,5 times the technically permissible trailer mass; in addition, the load/deformation curve shall show a smooth progression, without irregularities, in the interval between 500 daN and 1/3 of the maximum traction load.

3.3.3.2.1.4.2.1 Permanent deformation is recorded on the load/deformation curve in relation to the load of 500 daN after the test load has been brought back to that value.

3.3.3.2.1.4.2.2 The permanent deformation value recorded shall not exceed 25 % of the maximum elastic deformation occurring.

3.3.3.2.1.5 The test referred to in point 3.3.3.2.1.4.2 shall be preceded by a test in which an initial load of three times the maximum permissible vertical force (in daN, equal to $g \cdot S/10$) recommended by the manufacturer is applied in a gradually increasing manner, starting from an initial load of 500 daN, to the reference centre of the coupling device.

During the test, deformation of the coupling device shall not exceed 10 % of the maximum elastic deformation occurring.

The check is carried out after removing the vertical force (in

daN, equal to $g \cdot S/10$) and returning to the initial load of 500 daN.

3.3.4 Piton-type couplings (Class h)

As in 3.1.3 of this annex.

3.3.5 Clevis-type drawbar coupling, non-swivel around longitudinal axis (Class q)

As in 3.3.3 of this annex.

3.3.6 Keeper plates (for all drawbar couplings of Classes a, g and h, where present)

For ball, hook and piton-type couplings and equivalent devices, the keeper plate shall be tested using a static force of $F_{s \text{ stat}} = 0.6 \cdot D$ (vertically upwards). The Drawbar eyes may not be released and no permanent deformation which would be detrimental to the satisfactory operation of the device is permitted.

3.4 Drawbar eyes (Classes d)

3.4.1 Drawbar eyes (Classes d1 and d2) for clevis-type couplings shall be subjected to the same dynamic tests and equivalent loading assumptions (see 3.3.1).

For Drawbar eyes which are used exclusively on full trailers, a test using the horizontal loading assumptions shall be performed.

The test may be performed applying either an alternating or a pulsating test force as specified in 3.3.1.

3.4.2 Drawbar eyes (Classes d3 and d4) for hitch hooks, tractor drawbars or piton-type couplings shall be tested in the same way as Drawbar eyes for clevis-type couplings.

3.5 Drawbar eyes (Class r)

As in 3.3.3 of this annex.

3.6 Towing brackets (Class f)

3.6.1 Towing brackets shall be subjected to the same forces during testing as the coupling. The test load shall be applied at a horizontal and vertical distance corresponding to the position of the coupling device which exerts the least favourable load on the towing bracket.

3.6.2 Towing brackets with connections for a quick height-adjustable latching rail plate on the point of coupling side shall be subject to a static test in the transverse direction.

Force $0.6 \cdot D$ (kN)

Angle of application 60° to the longitudinal centre line

Point of force application to the coupling point see 3.6.1.

3.6.3 Test preparation

The tests must be carried out on a special machine, with the towing bracket device and any structure connecting it to the body of the tractor attached to a rigid structure by means of the same components used to mount it on the tractor.

3.6.4 Test instruments

The instruments used to record loads applied and movements must have the following degree of accuracy:

- loads applied ± 50 daN,
- movements $\pm 0,01$ mm.

3.6.5 Test procedure

The towing bracket device must first be subjected to a pre-traction load which does not exceed 15 % of the traction test load defined above. The above operation described must be repeated at least twice, starting with a zero load, which is gradually increased until the value prescribed is reached, and then decreased to 500 daN; the settling load must be maintained for at least 60 seconds.

The data recorded for plotting the load/deformation curve under traction, or the graph of that curve provided by the printer linked to the traction machine, must be based on the application of increasing loads only, starting from 500 daN, in relation to the reference centre of the towing bracket device.

There must be no breaks for values up to and including the traction test load; in addition, the load/deformation curve must show a smooth progression, without irregularities, in the interval between 500 daN and 2/3 of the maximum traction load.

Permanent deformation is recorded on the load/deformation curve in relation to the load of 500 daN after the test load has been brought back to that value.

During the test, permanent deformation of the towing bracket device must not exceed 10 % of the maximum elastic deformation occurring. The check is carried out after removing the load and returning to the initial load of 500 daN.

Annex 7

INSTALLATION AND SPECIAL REQUIREMENTS

1. Height above ground for vehicles of category T

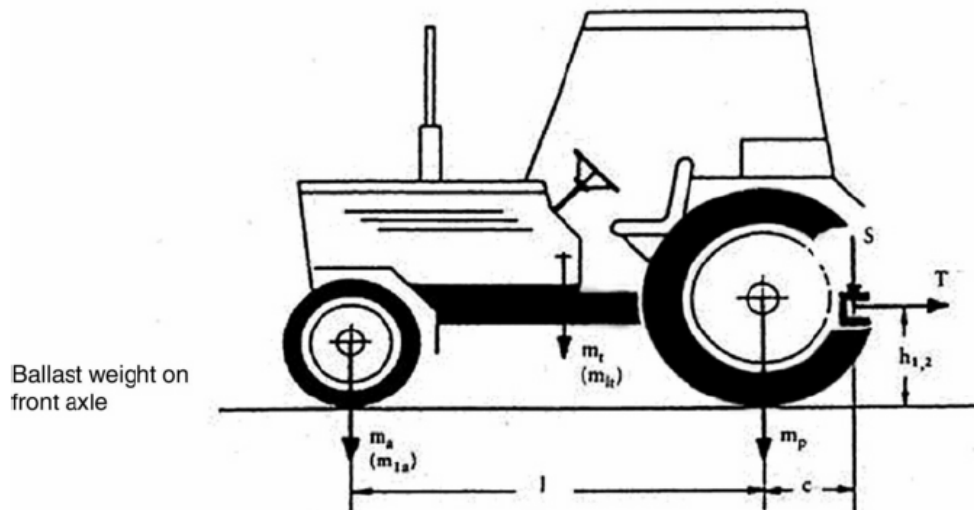

All tractors with a loaded mass exceeding 2,5 tonnes must be fitted with a trailer coupling having a ground clearance satisfying one of the following relations:

$$h_1 \leq ((m_a - 0,2 \times m_t) \times l - (S \times c) / (0,6 \times (0,8 \times m_t + S)))$$

or

$$h_1 \leq ((m_{1a} - 0,2 \times m_t) \times l - (S \times c) / (0,6 \times (0,8 \times m_{1t} - 0,2 \times m_t +$$

S))

where:

- m_t : mass of the tractor (see Annex I, point 1.6),
- m_{1t} : mass of the tractor (see Annex I, point 1.6) with ballast weight on the front axle,
- m_a : weight on the front axle of the unladen tractor (see Annex IV, point 1.9),
- m_{1a} : weight on the front axle of the tractor (see Annex IV, point 1.9) with ballast weight on the front axle,
- l : tractor wheelbase (see Annex IV, point 1.8),
- S : vertical load on the coupling point (see Annex IV, point 1.6),
- c : distance between the reference center of the mechanical coupling and the vertical plane passing through the axle of the rear wheels of the tractor.