

5 November 2015

Global technical regulation on tyres

Contents

	<i>Page</i>
I. Statement of technical rationale and justification.....	53
A. Introduction	53
B. Background of tyre regulations.....	53
C. Procedural background and development of the global technical regulation.....	64
D. Technical and economic feasibility	109
E. Anticipated benefits	109
F. Potential cost effectiveness.....	109
II. Text of the global technical regulation.....	110
1. Scope	110
2. Definitions	110
3. Requirements	1517
3.1. Plant codes.....	1517
3.2. Marking	1617
3.3. Other sidewall markings.....	1718
3.4. Tread wear indicators	1920
3.5. Physical dimensions of passenger car tyres	1921
3.6. Strength test for passenger car tyres	2223
3.7. Tubeless tyre bead unseating resistance test for passenger car tyres.....	2324
3.8. Tyre rolling sound emission test.....	2628
3.9. Endurance test for passenger car tyres.....	3335
3.10. Low inflation pressure performance test for passenger car tyres.....	3436
3.11. High speed performance test for passenger car tyres.....	3537

3.12.	Test for adhesion performance on wet surfaces.....	3840
3.13.	Procedure to assess the flat tyre running mode of run flat tyres	4565
3.14.	Strength test for LT/C tyres	4666
3.15.	Tubeless tyre bead unseating resistance test for LT/C tyres with rim codes of 10 or greater	4767
3.16.	Load/speed endurance test for LT/C tyres	5070
3.17.	Endurance test for LT/C tyres	5272
3.18.	Low inflation pressure performance test for LT/C tyres	5373
3.19.	High speed performance test for LT/C tyres	5575
3.20.	Physical dimensions of LT/C tyres (From FMVSS 139).....	5676
3.21.	Physical dimensions of LT/C tyres (From Regulation No. 54)	5776
3.22.	Tyre rolling resistance test.....	xx78
3.23.	Snow performance test relative to snow tyre for use in severe snow conditions.....	xx89
 Annexes		
1	Speed symbol table	59102
2	Load index (LI) and equivalent load capacity table	60103
3	Nominal rim diameter code table	61104
4	Relation between the pressure index ('psi') and the units of pressure (kPa)	62105
5	Variation of load capacity with speed commercial vehicles tyres.....	64107
6	Specifications for the rolling sound emissions test site	66
76	Tyre-size designations and dimensions	73116
8	Test report Rolling sound emissions for tyres	78
9	Test report Adhesion on wet surface.....	80
107	Tyre standards organizations.....	82127
8	Rolling resistance test equipment tolerances.....	xx128
9	Measuring rim width.....	xx131
10	Deceleration method - Measurements and data processing for deceleration value obtaining in differential form $d\omega/dt$	134

I. Statement of technical rationale and justification

A. Introduction and procedural background

1. The objective of this global technical regulation (gtr) is to establish provisions for new radial pneumatic tyres equipping passenger cars and light truck (commercial) vehicles up to and including 4,536 kg (10,000 pounds) under the 1998 Agreement. The official bases of this harmonized set of requirements are Regulations Nos. 30, and 54 and 117 annexed to the 1958 Agreement, as well as the Federal Motor Vehicle Safety Standard (FMVSS) 139 requirements established in the United States of America under the direction of the National Highway Traffic Safety Administration (NHTSA). Regulations from Gulf States Organization (GSO), India and China, although not officially registered in the compendium of regulations for the tyre gtr, were also analysed and requirements from them were considered in this gtr insofar as they were not already covered by one of the regulations from UNECE and United States of America. In addition, parts of FMVSS 109 and 119 were copied directly into this gtr, since they are applicable to certain tyres for light commercial vehicles (LT or C tyres).

2. Many countries throughout the world have already introduced regulations concerning pneumatic tyres. Many of the existing regulations are based on the four primary ones mentioned above. However, many differences in test conditions and regulatory marking requirements require tyre manufacturers to produce almost identical products but with market specific variations to meet local market requirements – including slight variations on sidewall marking provisions.

3. This first phase of the gtr for tyres harmonizes the requirements for passenger car tyres. Work is on-going to define the technical specification for the harmonization of tyres with the designations LT or C which are primarily fitted on light commercial vehicles.

4. Additional technical evaluation is necessary to assess whether consideration should be given for certain tyre types typical in the North American market in relation to the specifications in paragraph 3.12. (referring to the test for adhesion performance on wet surfaces). Government and industry in the United States of America are coordinating to conduct this evaluation.

4 bis. For the purposes of future harmonization, it is noted that amendments are anticipated in the areas of the Strength test for passenger car tyres (section 3.6) and the Tubeless tyre bead unseating resistance test for passenger car tyres (section 3.7). For both tests, work is underway in the United States to modify the test conditions or performance requirements to accommodate certain tyre sizes.

Following additional technical evaluation of the adhesion performance on wet surfaces (section 3.12), a future additional category of use might be necessary for certain tyre types typical in the North American market.

B. Background of tyre regulations

5. Radial pneumatic tyres for passenger cars and light vehicles are increasingly becoming worldwide products, expected to be used anywhere in the world when mounted as original equipment on new vehicles which are themselves marketed on a global basis. This globalization creates significant opportunities for manufacturers to deliver better and

more cost efficient products but also requires harmonization of the technical provisions at a global level to avoid increasing manufacturing costs.

6. Although testing requirements for different regulations used around the world are often substantially similar, slight variations in test procedures oblige tyre manufacturers to test the same object for the same performance characteristic under slightly different conditions, without any significant improvement in the final product.

7. Marking requirements are also variable around the world, and the same tyre may need several different approval marks to be marketed in a truly worldwide fashion. Any harmonization of such markings should continue to be a priority, as it would clarify the administrative identity of the tyre and facilitate the management of production moulds.

C. Procedural background and development of the global technical regulation

8. This gtr was developed by the GRRF informal working group on the Tyre GTR.

9. The work on this gtr began informally in December of 2004 with a meeting in Paris. As required by the 1998 Agreement, a formal proposal for the establishment of a tyre gtr was proposed to the Executive Committee of the 1998 Agreement (AC.3) by the technical sponsor, France. At the 140th session of the World Forum for Harmonization of Vehicle Regulations (WP.29) on 14 November 2006, the French proposal was approved as a gtr project by AC.3 (ECE/TRANS/WP.29/2006/139). The adopted proposal was published as ECE/TRANS/WP.29/AC.3/15.

10. Subsequent to that approval, the informal working group on Tyre GTR met on numerous occasions. In addition to three unofficial meetings held between December 2004 and November 2006, another ten meetings were scheduled in conjunction with GRRF sessions and a further two interim meetings were held in Brussels in July 2007 and July 2009.

11. In 2009, at the request of the informal working group, AC.3 approved the development of the gtr in two phases: the initial phase being dedicated to harmonizing requirements for passenger car tyres only, and requirements for light truck tyres, which carry a C or LT designation, to be harmonized as a second phase. In the interim, the existing requirements for C or LT tyres (albeit non-harmonized) are included in the first stage of the gtr for completeness. The current document reflects that decision and contains only harmonized requirements for passenger car tyres, with the LT/C requirements remaining to be harmonized.

12. Tests or requirements for radial passenger car tyres required extensive harmonization during the course of the informal working group's mandate. These newly harmonized tests or requirements are:

- (a) High speed test;
- (b) Physical dimensions test;
- (c) Required markings.

13. Several other test requirements for radial passenger car tyres existed only in one of the existing regulations and needed no harmonization. These tests were simply included as direct copies in the gtr for tyres. In particular, no harmonization was required for:

- (a) Endurance test;
- (b) Low pressure endurance test;

- (c) Bead unseating test;
- (d) Strength test;
- (e) Rolling sound emission test;
- (f) Wet grip test;
- (g) Run flat test.

14. Harmonizing the high speed test posed a significant challenge in that the two existing tests were quite different from each other and based on different principles. One was designed to ensure that a tyre would perform adequately at speeds well above a national speed limit, but the test requirements were not related to any speed symbol indicated on the tyre itself. The other required that a tyre pass a test at its highest rated speed.

15. Taking into account the long experience of FMVSS standards in the United States of America and in countries applying Regulation No. 30, and the huge amount of test results corresponding to these two testing procedures, it was decided to base harmonization on a combination of the two existing test procedures rather than develop a wholly new harmonized test procedure. The harmonization work was based on a determination of which test was more onerous for tyres of different speed symbols, and using the best test procedure.

16. At the meeting of the ad hoc working group in September 2006, three different scenarios for the high speed test harmonization were discussed. One of the options considered was to use the FMVSS 139 high speed test for tyres with a speed rating equivalent to the symbol of "S" and below (less than or equal to 180 km/h), and the Regulation No. 30 test for speed symbols above "S" (greater than 180 km/h). At that meeting, there was a general consensus by the Contracting Parties that this proposal could be considered as a starting point, but it would require significant further work in order to demonstrate the validity of the proposal.

17. The tyre industry presented a theoretical method to determine, for each speed symbol, the test which is the most severe and to validate that the equivalence point (the speed symbol for which both tests are equally severe) between the two tests is reached at a specific speed symbol. Over the following year the tyre industry gathered data to demonstrate this concept. Six tyre manufacturers supplied data, and in total, 704 tyres were tested using both tests. All the tyres were tested above and beyond the normal high speed test requirements, and the number of steps that each tyre was able to withstand above the regulatory limit, were counted. The ratio of the number of Steps above the Limit (SAL) for the FMVSS 139 test, divided by the number of steps above the limit for Regulation No. 30 test was used to evaluate the data. Based on this extensive set of data, it was determined that the FMVSS 139 high speed test was more severe for tyres with speed symbol of S and below (less than or equal to 180 km/h). The Regulation No. 30 high speed test was more severe for tyres with speed symbols of T (190 km/h) and above.

18. To validate this concept further, work was undertaken on a smaller sample of tyres to determine the temperature increase during the different tests. In all cases, it was demonstrated that for T rated tyres and above, greater energy input was required (as determined by the increase in the contained air temperature) during the Regulation No. 30 test than from the FMVSS 139 test. This data was also independently confirmed by one of the Contracting Parties. Since the increase in temperature of a tyre should be directly related to the amount of energy supplied during the test, a higher internal tyre temperature at the end of a test indicates a higher degree of severity. At the meeting in September 2008, it was agreed to use the Regulation No. 30 test for tyres with speed symbols of T (190 km/h) and above, and to use the FMVSS 139 high speed test for all lower speed symbols (180 km/h and below).

19. The physical dimensions test was less difficult to harmonize from a technical point of view, because of the elementary simplicity of determining the outside diameter and width of a tyre in its inflated state to ensure interchangeability between tyres marked with the same size designation. A small but not insignificant gain has been achieved by harmonizing the measuring of the tyre's width at four points around the circumference.

20. After the inventory of different tests for passenger car tyres existing in the world had been made, it appeared that some of these tests might be harmonized on a worldwide level, while some of them appeared to have a more regional application. In order to take this situation into account, the technical sponsor of the tyre gtr proposed to organize the different tests into three modules:

For gtr compliance at least the mandatory requirement plus either module 1 or 2 are required (compliance with both modules is permitted).	Mandatory minimum requirement 1.1 Marking 1.2 Dimensions 1.3 Harmonized high speed safety test 1.4 Endurance/Low pressure test 1.5 Tyre Wet Grip adhesion
	Module 1 – Permissive requirement 2.1 Plunger energy test 2.2 Bead unseating test
	Module 2 – Permissive requirement 3.1 Tyre rolling sound

21. This modular structure was described in document ECE/TRANS/WP.29/AC.3/15 that was adopted by AC.3 as the formal request of authorisation to develop the gtr.

22. The informal working group developing the gtr pursued the modular approach. As the group continued to develop the modular approach a wider appreciation among Contracting Parties of the application of modules emerged. This prompted proposals for a less prescriptive approach to some of the individual elements included in the mandatory module. The informal group considered alternatives to deliver the requirements of Contracting Parties while retaining the original modular approach but could not find a sufficiently robust solution. As a result the group proposes a revised structure centred upon a "General Module" plus two options (Options 1 and 2). These are described in the table.

<i>Passenger car tyres</i>		
	<i>Test name</i>	<i>Paragraph(s)</i>
	Marking and tread wear indicators	3.2., 3.3. and 3.4.
	Physical dimensions	3.5.
	High speed test	3.11.

<i>Passenger car tyres</i>		
	<i>Test name</i>	<i>Paragraph(s)</i>
General module	Endurance test	3.9.
	Low pressure test	3.10.
	Wet grip test	3.12.
	Run flat test	3.13.
Option 1	Strength test	3.6.
	Bead unseating test	3.7.
Option 2	Rolling sound emissions	3.8.

23. In this initial version of the gtr for tyres, the harmonized requirements apply only to tyres for passenger cars. The module concept does not apply to LT/C tyres and the following table describes the tests applicable to these tyres.

<i>LT/C tyres</i>	<i>C type tyres</i>	<i>LT type tyres</i>
<i>Test name</i>	<i>Paragraphs related to Regulation No. 54</i>	<i>Paragraphs related to FMVSS 139</i>
Marking and tread wear indicators	3.2., 3.3. and 3.4.	3.2., 3.3. and 3.4.
Physical dimensions	3.21.	3.20.
High speed test	3.16.	3.19.
Endurance test	3.16.	3.17.
Low pressure test	None	3.18.
Wet grip test	None	None
Run flat test	None	None
Strength test	None	3.14.
Bead unseating test	None	3.15.
Rolling sound emissions	3.8.	None

23-bis. However, since the gtr contains only technical prescriptions and no legal aspects concerning implementation of this gtr in national/regional legislation of the Contracting Parties to the 1998 Agreement, irrespectively to the above described module concept, only a Contracting Party decides how to transpose the gtr provisions into its national/regional legislation. In order to facilitate the transposition process it may be recommended to apply a stepwise approach and for the first stage to select just those provisions and test methods of the gtr, which mostly suit the regulatory needs of a Contracting Party, and to consider, when introducing new performance requirements, the possible trade-offs with the other performances. For example, when adopting rolling resistance provisions together with wet grip provisions attention to be put to make sure that one performance is not optimized at the expense of the other. Meanwhile, it is anticipated that a Contracting Party will allow access to its internal market for tyres complying with the provisions of the gtr that the

Contracting Party has not adopted if such tyres are in compliance with national/regional legislation of that Contracting Party.

24. In the case of required markings, it was possible to eliminate some that had become unnecessary over the years, such as the words Radial and Tubeless. Indeed over 90 per cent of passenger car tyres and LT/C tyres sold worldwide are radial and tubeless construction and so continuing to mark tyres is unnecessary. In addition, a change was made in the way the Tyre Identification Number (TIN) will be used in combination with other markings.

25. The TIN format is based on NHTSA's plan to change the currently assigned 2 digit plant codes to 3 digits. A symbol, the number "1" for example, will be reserved to precede all current 2-digit codes, and be used exclusively for existing plant codes. The "1" would only be used as the prefix for existing 2-digit codes, and not be used as the leading digit for any new 3-digit codes. NHTSA will continue to assign global plant codes and the necessary information to obtain such a code is contained within the gtr.

26. The aim of the tyre gtr is to introduce the universal worldwide harmonized requirements to tyres included into the scope of the gtr. In accordance with the provisions of the 1998 Agreement, once the gtr is adopted, those Contracting Parties voting in favour of its adoption will start the process of transposing those requirements into their national legislation.

In a case when a test procedure includes several options, a Contracting Party may select the option(s) at its discretion.

In the interests of moving rapidly towards creating a "global tyre" approach the informal group suggests that Contracting Parties transpose the gtr requirements in a flexible way to permit tyres complying with the full requirements access to as many markets as possible.

27. Consideration was given to harmonize the approval markings (both type approval and self-certification markings) and discussions on this issue were elevated to WP.29 and AC.3 meetings. It was concluded as not possible currently to adopt a harmonized approval marking since the compliance assessment procedures are not yet harmonized worldwide. So this gtr contains no administrative provisions on approval markings. In the absence of a harmonized marking, the Contracting Parties retain the option to assign markings to tyres, especially markings for a "global tyre", and these can be introduced within their national / regional compliance assessment systems.

28. It is anticipated that the Contracting Parties will incorporate the provisions of the gtr into regulations within their legal framework. This may include applying suitable tyre marking and so help provide for market recognition between the Contracting Parties of tyres complying with the provisions of this gtr. Such an approach might encourage wider recognition of harmonized markings and thus further the move towards a single global marking where tyres meet the full requirements established by this gtr.

28-bis. In parallel to development of this gtr, UN Regulation No. 117, which is a base for this gtr, had been amended several times by detailing and extending the provisions to tyre wet grip performance, adding the provisions for rolling resistance and for classification as snow tyre for use in severe snow conditions for all tyre classes included in its scope. As harmonization of the newly introduced provisions of UN Regulation No. 117 was not feasible in a reasonable time frame, the decision for this gtr was not to consider those provisions for inclusion in the text of the gtr at that time. Those new provisions represent the state-of-the art level and are important for assessment of performance of tyres on the markets worldwide. Therefore at so-called "Phase 1b" the relevant provisions aligned with those of UN Regulation No. 117 are introduced by the Amendment No. 1 to this gtr.

28-ter. The Amendment No. 1 to this gtr incorporates:

(a) Amendment of Part I by adding new paragraphs 4-bis, 23-bis, 28-bis and 28-ter;

(b) Amendment of Part II:

- (i) Addition of new definitions (Section 2);**
 - (ii) Modification of test for adhesion performance on wet surfaces (Section 3.12);**
 - (iii) Addition of new requirements to rolling resistance (new Section 3.22);**
 - (iv) Addition of new requirements for qualification of a tyre to be designated for use in severe snow conditions (new Section 3.23);**
- (c) Addition of new Annexes containing the details of the newly added test methods.**

D. Technical and economic feasibility

29. The tyre gtr has been developed by drawing on the experience of many stakeholders, including regulatory authorities, type approval authorities, tyre and vehicle manufacturers and technical consultants. The gtr has been built upon the experience of many organizations and individuals with expertise in the area of tyres for passenger cars and light trucks or light commercial vehicles.

30. The tyre gtr has been designed to update and improve upon existing regulations, and the requirements are based on existing concepts in different Contracting Parties' present regulations.

31. Since this gtr is based on existing requirements and some harmonized tests, no economic or technical feasibility study was deemed necessary. When transposing this gtr into national legislation, Contracting Parties are invited to consider the economic feasibility of the gtr in the context of their country.

E. Anticipated benefits

32. The principal economic benefit of this regulation will be a reduction in the variety of tests for the same or substantially similar requirements.

33. Depending on how different Contracting Parties implement this gtr, there may be benefits due to the way the approval markings are treated. Tyre mould design and fabrication might be rationalized, with associated reductions in production costs.

34. Safety benefits resulting from the transposition of the gtr in the national legislations depend on the previous level of the national regulations.

F. Potential cost effectiveness

35. It is not possible to assess, at this moment, the total costs linked to the gtr. On one hand, there are more tests in the gtr than in the existing national or international regulations; on the other hand the harmonization of the regulation will reduce the global cost of type approval in the variety of countries which will apply the gtr through that administration procedure.

36. Safety benefits are anticipated, but it is not yet possible to assess them in terms of reduction of number of accidents and victims.

II. Text of the global technical regulation

1. Scope

- 1.1 This global technical regulation covers new radial pneumatic tyres designed primarily for vehicles in Categories 1 and 2, all with a gross vehicle mass of 4,536 kg or less, as defined in the Special Resolution No. 1.¹
- 1.2 It does not apply to:
- T-Type temporary use spare tyres;
 - Tyres having a nominal rim diameter code ≤ 8 (or ≤ 203 mm).
- 1.3 Contracting Parties may also optionally decide to exclude:
- Special Tyres (ST) for trailers in highway service;
 - LT or C tyres with tread-depth of greater than or equal to 14.3 mm (18/32 inch).

2. Definitions

For the purpose of this regulation the following definitions apply:

- 2.1. **"Acceleration test" means a series of specified number of traction controlled acceleration test runs of the same tyre repeated within a short timeframe;**
- 2.24. "Adhesion on wet surfaces" means the relative braking performance, on a wet surface, of a test vehicle equipped with the candidate tyre in comparison to that of the same test vehicle with a reference tyre (SRTT);
- 2.32. "Basic tyre functions" means the nominal capability of an inflated tyre in supporting a given load up to a given speed and transmitting the driving, the steering and the braking forces to the ground on which it runs;
- 2.43. "Bead" means the part of the tyre which is of such shape and structure as to fit the wheel rim and hold the tyre on it;
- 2.54. "Bead separation" means a breakdown of the bond between components in the tyre bead area;
- 2.6. **"Braking force of a tyre" means the longitudinal force, expressed in newton, resulting from braking torque application;**
- 2.7. **"Braking force coefficient of a tyre (BFC)" means the ratio of the braking force to the vertical load;**
- 2.8. **"Braking test" means a series of a specified number of ABS-braking test runs of the same tyre repeated within a short time frame;**
- 2.95. "Brand name, Trade name or Trade mark" means an identification applied to the tyre which may be the name or mark of the manufacturer or of a customer

Comment [AR1]: Revision 2 – Amendment 1
Supplement 1 to the 02 series of amendments - Date of entry into force: 18 November 2012
WP.29/2012/2

Comment [JN2]: Revision 2 – Amendment 1 of Reg. 117
Supplement 1 to the 02 series of amendments - Date of entry into force: 18 November 2012
WP.29/2012/2

Comment [JN3]: Revision 2 – Amendment 1 of Reg. 117
Supplement 1 to the 02 series of amendments - Date of entry into force: 18 November 2012
WP.29/2012/2

Comment [JN4]: Annex 7 of Reg. 117

¹ Document ECE/TRANS/WP.29/1045, as amended.

for whom the manufacturer is producing tyres for subsequent resale (that is, "Own Branding");

- 2.10. "**Candidate tyre(s)**" means a tyre or a tyre set that is tested for the purpose of calculating its wet or snow grip index.
- 2.11. "**Capped inflation**" means the process of inflating the tyre and allowing the inflation pressure to build up as the tyre is warmed up while running;
- 2.126. "Carcass" means that part of the pneumatic tyre structure other than the tread and sidewall rubber, which, when inflated, bears the load;
- 2.137. "Chunking" means the breaking away of pieces of the tread or sidewall;
- 2.148. "Class C1 tyres" means tyres designed primarily for vehicles of Category 1-1 of Special Resolution No. 1;
- 2.159. "Class C2 tyres" means tyres designed primarily for vehicles of Categories 1-2 and 2 of Special Resolution No. 1 with a load index in single formation ≤ 121 and the speed symbol \geq "N";
- 2.160. "Class C3 tyres" means tyres designed primarily for vehicles of Category 2 of Special Resolution No. 1 with a load index in single formation ≤ 121 and the speed symbol \leq "M", or with a load index in single formation ≥ 122 ;
- 2.17. "**Control tyre**" means a normal production tyre that is used to establish the wet grip or snow grip performance of tyre sizes unable to be fitted to the same vehicle as the standard reference test tyre ;
- 2.184. "Cord" means the strands or filaments of material forming the plies of the tyre structure;
- 2.192. "Cord separation" means the parting of cords from adjacent rubber compounds;
- 2.20. "**Coupling (hitch) height**" means the height when measured perpendicularly from the centre of the articulation point of the trailer towing coupling or hitch to the ground, when the towing vehicle and trailer are coupled together. The vehicle and trailer shall be standing on level pavement surface in its test mode complete with the appropriate tyre(s) to be used in the particular test;
- 2.2143. "CP tyre" means a commercial vehicle tyre for service on motor caravans;
- 2.2244. "Cracking" means any parting within the tread, sidewall or inner liner of the tyre which may or may not extend to cord material;
- 2.2345. "Deflected section height" is the difference between the deflected radius, measured from the centre of the rim to the surface of the drum, and one half the nominal rim diameter as defined in ISO 4000-1:2010;
- 2.24. "**Extra Load**" means a pneumatic-tyre structure designed to carry more load at a higher inflation pressure than the load carried by the corresponding standard version tyre at the standard inflation pressure as specified in ISO 4000-1:2010;
- 2.2546. "Flat tyre running mode" describes the state of the tyre, essentially maintaining its structural integrity, while operating at an inflation pressure between 0 and 70 kPa, for runflat tyres or systems;

Comment [JN5]: Paragraph 2.17.2. of Reg. 117

Comment [JN6]: Paragraph 2.18.5. of Reg. 117

Comment [JN7]: Revision 2 - Amendment 2 of Reg. 117
Supplement 2 to the 02 series of amendments - Date of entry into force: 15 July 2013
WP.29/2012/54

Comment [JN8]: Paragraph 2.17.8. of Reg. 117

Comment [JN9]: Revision 3 - Amendment 3 of Reg. 30
Supplement 17 to the 02 series of amendments - Date of entry into force: 27 January 2013
Document ECE/TRANS/WP29/2012/48 as amended by para. 50 of the report 157th session June 2012.

- 2.2647. "Inner liner" means the layer of rubber forming the inside surface of a tubeless tyre that contains the inflating medium within the tyre;
- 2.27. **"Inertia or Moment of Inertia²" means the ratio of the torque applied to a rotating body to the rotational acceleration of this body² ;**
- 2.248. "Intended outboard sidewall" means the sidewall that contains a whitewall, bears white lettering, or bears manufacturer or model name moulding that is higher or deeper than that on the other sidewall of the tyre;
- 2.29. **"Laboratory Control Tyre³" means the tyre used by an individual laboratory to control machine behaviour as a function of time;**
- 2.3049. "Light Load tyre (LL)" means a tyre designed for loads lower than the standard load (SL) version;
- 2.3120. "Light truck (Commercial) tyre" means a tyre of a group prescribed in the light truck or "C" Commercial tyre section of the standards manuals of the organizations shown in Annex 740;
- 2.3224. "Load index" means one or two numbers which indicate the load the tyre can carry in single or in single and dual operation at the speed corresponding to the associated speed category. A type of pneumatic tyre can have either one or two sets of load indices. The list of these indices and their corresponding loads is given in Annex 2;
- 2.3322. "Load capacity variation with speed" means an authorized variation of the reference mass, as indicated by the load index, based on the actual in-use speed in comparison with the capabilities indicated by the service description (see Annex 5);
- 2.3423. "Load range" means a letter (B, C, D, or E) used to identify a given LT size tyre with its load classification and inflation limits;
- 2.35. **"Lockup of a wheel¹" means the condition of a wheel in which its rotational velocity about the wheel spin axis is zero and it is prevented from rotating in the presence of applied wheel torque;**
- 2.36. **"Measurement reproducibility σ_m " means the capability of a machine to measure rolling resistance³ ;**
- 2.3724. "Maximum application load capacity" means the maximum mass a tyre can support in a specific application, and is dependent on the speed symbol of the tyre, the maximum design speed of the vehicle on which the tyre is fitted, the inflation pressure and the camber angle of the wheels of the vehicle;

Comment [JN10]: Paragraph 2.18.8. of Reg. 117

Comment [JN11]: Paragraph 2.18.4. of Reg. 117

Comment [JN12]: Revision 2 – Amendment 1 of Reg. 117 Supplement 1 to the 02 series of amendments - Date of entry into force: 18 November 2012 WP.29/2012/2

Comment [JN13]: Paragraph 2.18.9. of Reg. 117

² The rotating body can be, for example, a tyre assembly or machine drum.

³ Measurement reproducibility σ_m shall be estimated by measuring n times (where $n \geq 3$), on a single tyre, the whole procedure described in paragraph 3.22.5. as follows:

$$\sigma_m = \sqrt{\frac{1}{n-1} \cdot \sum_{j=1}^n \left(Cr_j - \frac{1}{n} \cdot \sum_{j=1}^n Cr_j \right)^2}$$

Where:

j = is the counter from 1 to n for the number of repetitions of each measurement for a given tyre,

n = number of repetitions of tyre measurements ($n \geq 3$).

- 2.3825. "Maximum load rating" means the load corresponding to the load index;
- 2.3926. "Maximum permissible inflation pressure" means the maximum cold inflation pressure to which the tyre may be inflated;
- 2.40. **"Mean fully developed deceleration ("mfdd")" means the average deceleration calculated on the basis of the measured distance recorded when decelerating a vehicle between two specified speeds;**
- 2.4127. "Measuring rim" means an actual rim of specified width as defined by one of the standards organizations as specified in Annex 740, on which the tyre is fitted for measuring the physical dimensions;
- 2.4228. "Nominal aspect ratio (profile)" means the ratio of the nominal section height to the nominal section width expressed as a percentage in a multiple of 5 (ending in 0 or 5);
- 2.4329. "Nominal section width" shall be indicated in millimetres, and this part of the designation shall end in either the number zero or five, so that in any single series of tyres with the same nominal aspect ratio, the values shall all end in "0" or they shall all end in "5";
- 2.4430. "Normal tyre" means a tyre intended for normal on-road use;
- 2.4534. "Open splice" means any parting at any junction of tread, sidewall, or inner liner that extends to cord material;
- 2.4632. "Outer diameter" means the overall diameter of an inflated new tyre;
- 2.4733. "Overall width" means the linear distance between the outsides of the sidewalls of an inflated pneumatic tyre, including elevations due to labelling (marking), decorations, and/or protective bands or ribs;
- 2.48. **"Parasitic loss" means loss of energy (or energy consumed) per unit distance excluding internal tyre losses, attributable to aerodynamic loss of the different rotating elements of the test equipment, bearing friction and other sources of systematic loss which may be inherent in the measurement;**
- 2.4934. "Passenger tyre" means a tyre of a group prescribed in the passenger tyre section of the standards manuals from one of the organizations shown in Annex 740;
- 2.5035. **"Peak brake force coefficient ("pbfc")" means the maximum value of the ratio of braking force to vertical load on the tyre prior to wheel lock-up, of a tyre braking force coefficient that occurs prior to wheel lockup as the braking torque is progressively increased;**
- 2.5136. "Ply" means a layer of rubber-coated parallel cords;
- 2.5237. "Ply separation" means a parting of adjacent plies;
- 2.5338. "Pneumatic tyre" means a form of tyre comprising a reinforced flexible envelope which is either provided with, or forms in conjunction with the wheel upon which it is mounted, a continuous, closed, essentially toroidal chamber containing a gas, (usually air), or gas and a liquid, which is intended to be used at a pressure greater than atmospheric pressure. A pneumatic tyre may be classified as a passenger tyre (see "passenger tyre" above), or a light truck (commercial) tyre, (see "light truck (commercial) tyre" above), depending on the service duty conditions required for any specific application;

Comment [JN14]: Paragraph 2.17.7 of Reg. 117

Comment [JN15]: Paragraph 2.18.6. of Reg. 117

Comment [JN16]: Based on paragraph 2.8 of annex 5 of Reg. 117.

- 2.5439. "Principal grooves" means the wide **circumferential** grooves positioned in the central zone of the tyre tread, which, in the case of passenger and light truck (commercial) tyres, have the tread wear indicators located in the base;
- 2.55. "**Professional off-road tyre**" is a special use tyre primarily used for service in severe off-road conditions.
In order to be classified as a **professional off-road tyre**, a tyre shall have all of the following characteristics:
- (a) For C1 and C2 tyres:
- i) A tread depth ≥ 11 mm;
- ii) A void-to-fill ratio ≥ 35 per cent;
- iii) A maximum speed symbol $\leq Q$.
- (b) For C3 tyres:
- i) A tread depth ≥ 16 mm;
- ii) A void-to-fill ratio ≥ 35 per cent;
- iii) A maximum speed symbol $\leq K$.
- 2.5640. "PSI index" is a code identifying the inflation pressure which may be used during testing of tyres as shown in Annex 4;
- 2.5744. "Radial ply tyre" means a pneumatic tyre structure in which the ply cords that extend to the beads are laid at substantially 90° to the centreline of the tread, the carcass being restrained by circumferential belts of 2 or more layers of substantially inextensible cord material;
- ~~2.42. "Extra load tyre" means a passenger car tyre designed to operate at higher loads and at higher inflation pressures than the corresponding standard load tyre;~~
- 2.5843. "Rim" means that part of the wheel forming the support for the tyre and on which the tyre beads are seated;
- 2.5944. "Rim protector" means a feature (for example: a protruding circumferential rubber rib) incorporated into the lower sidewall area of the tyre which is intended to protect the rim flange from damage;
- 2.60. "**Rolling resistance coefficient C_r** " means the ratio of the rolling resistance to the load on the tyre⁴ ;
- 2.61. "**Rolling resistance F_r** " means the loss of energy (or energy consumed) per unit of distance traveled⁵ ;
- 2.6245. "Run flat tyre" or "Self-supporting tyre" describes a pneumatic tyre structure provided with any technical solutions (for example, reinforced sidewalls, etc.) allowing the pneumatic tyre, mounted on the appropriate wheel and in the absence of any supplementary component, to supply the vehicle with the basic tyre functions, at least, at a speed of 80 km/h (50 mph) and a distance of 80 km when operating in flat tyre running mode;
- 2.6346. "Run flat system" or "Extended mobility system" describes an assembly or specified functionally dependant components, including a tyre, which

Comment [JN17]: Revision 3 – Amendment 3 of Reg. 30
Supplement 17 to the 02 series of amendments - Date of entry into force: 27 January 2013
Document ECE/TRANS/WP29/2012/48 as amended by para. 50 of the report 157th session June 2012.

Comment [JN18]: Revision 3 – Amendment 3 of Reg. 30
Supplement 17 to the 02 series of amendments - Date of entry into force: 27 January 2013
Document ECE/TRANS/WP29/2012/48 as amended by para. 50 of the report 157th session June 2012.
and
Revision 3 – Amendment 3 of Reg. 54
Supplement 17 to the 02 series of amendments - Date of entry into force: 27 January 2013
Document ECE/TRANS/WP29/2012/48 as amended by para. 50 of the report 157th session June 2012.

Comment [JN19]: Revision 3 – Amendment 3 of Reg. 30
Supplement 17 to the 02 series of amendments - Date of entry into force: 27 January 2013
Document ECE/TRANS/WP29/2012/48 as amended by para. 50 of the report 157th session June 2012
And
Revision 3 of Reg. 54
Supplement 18 to the original version of the Regulation - Date of entry into force: 27 January 2013
ECE/TRANS/WP.29/2012/49

Comment [JN20]: Paragraph 2.18.2. of Reg. 117

Comment [JN21]: Paragraph 2.18.1. of Reg. 117

⁴ The rolling resistance is expressed in newton and the load is expressed in kilo-newton. The rolling resistance coefficient is dimensionless.

⁵ The International System of Units (SI) unit conventionally used for the rolling resistance is the newton-meter per meter, which is equivalent to a drag force in newton.

together provide the specified performance granting conditions for the vehicle with at least basic tyre functions, at a speed of 80 km/h (50 mph) and a distance of 80 km (50 miles) when operating in flat tyre running mode;

- ~~2.6447.~~ "Secondary grooves" means the supplementary grooves of the tread pattern which may disappear in the course of the tyre's life;
- ~~2.6548.~~ "Section height" means a distance equal to half the difference between the outer diameter of the tyre and the nominal rim diameter;
- ~~2.6649.~~ "Section width" means the linear distance between the outside of the sidewalls of an inflated pneumatic tyre, excluding elevations due to labelling (marking), decoration or protective band or ribs;
- ~~2.6750.~~ "Service description" means the association of the load index or indices with a speed symbol (for example, 91H or 121/119S);
- ~~2.6851.~~ "Sidewall" means that portion of a tyre between the tread and the bead;
- ~~2.6952.~~ "Sidewall separation" means the parting of the rubber compound from the cord material in the sidewall;
- 2.70.** **"Skim test reading" means the type of parasitic loss measurement, in which the tyre is kept rolling without slippage, while reducing the tyre load to a level at which energy loss within the tyre itself is virtually zero;**
- 2.71.** **"Snow grip index ("SG")" means the ratio between the performance of the candidate tyre and the performance of the standard reference test tyre;**
- ~~2.7253.~~ "Snow tyre" means a tyre whose tread pattern, tread compound or structure is primarily designed to achieve in snow conditions a performance better than that of a normal tyre with regard to its ability to initiate or maintain vehicle motion;
- ~~2.7354.~~ "Snow tyre for use in severe snow conditions" means a snow tyre whose tread pattern, tread compound or structure is specifically designed to be used in severe snow conditions and that fulfils the requirements in paragraph **3.23; 6.4. and the tests in Annex 7 of Regulation No. 117;⁶**
- ~~2.7455.~~ "Special Tyres (ST) for trailers in highway service" means a tyre having the ST prefix or suffix in the tyre size. These tyres have higher allowable loads than the corresponding sized tyres without the ST designation and consequently are only allowed for use on trailers;
- ~~2.7556.~~ "Special use tyre" means a tyre intended for mixed use, both on and/or off road or for other special service duty. **These tyres are primarily designed to initiate and maintain the vehicle in motion in off-road conditions.**
- In order to be classified as a "special use tyre" a tyre shall have a block tread pattern in which the blocks are larger and more widely spaced than for normal tyres and have the following characteristics:**
- For C1 tyres: a tread depth \geq 11 mm and void to fill ratio \geq 35 per cent**
- For C2 tyres: a tread depth \geq 11 mm and void to fill ratio \geq 35 per cent**
- For C3 tyres: a tread depth \geq 16 mm and void to fill ratio \geq 35 per cent**

Comment [JN22]: Paragraph 2.18.7. of Reg. 117

Comment [JN23]: Paragraph 2.17.5. of Reg. 117

Comment [JN24]: Agreement given in GRRF 80th session that provisions for transposition into the National regulations will be removed from Part II and clarified in the introduction.

Comment [JN25]: Revision 3 – Amendment 3 of Reg. 30
Supplement 17 to the 02 series of amendments - Date of entry into force: 27 January 2013
Document ECE/TRANS/WP29/2012/48 as amended by para. 50 of the report 157th session June 2012.

Comment [JN26]: Revision 3 – Amendment 3 of Reg. 30
Supplement 17 to the 02 series of amendments - Date of entry into force: 27 January 2013
Document ECE/TRANS/WP29/2012/48 as amended by para. 50 of the report 157th session June 2012
And
Revision 3 of Reg. 54
Supplement 18 to the original version of the Regulation - Date of entry into force: 27 January 2013
ECE/TRANS/WP.29/2012/49

⁶ Contracting Parties may select the test procedure(s) at their discretion.

- 2.7657. "Speed symbol" means the letter code which defines the maximum speed which the tyre can sustain, (see Annex 1 to this regulation);
- 2.7758. "~~Standard Reference Test Tyre (SRTT)~~" means a tyre that is produced, controlled and stored in accordance with the ASTM ~~International Standard E 1136-93 (re-approved 1998)~~; (American Society for Testing and Materials) standards
- (a) **E1136-93 (2003) for the size P195/75 R 14**
 - (b) **F2493-08 (2008) for the size P225/60 R 16**
 - (c) **F2872 (2011) for the size 225/75 R 16 C.**
 - (d) **F2871 (2011) for the size 245/70 R 19.5**
 - (e) **F2870 (2011) for the size 315/70 R 22.5**
- 2.7859. "Structure" means the technical characteristics of the tyre's carcass (for example: radial, bias-belted, bias ply, etc.);
- 2.79. "~~SRTT14~~" means the ASTM E 1136-93 (Reapproved 2003), Standard Specification for a Radial Standard Reference Test Tire P195/75R14.
- 2.80. "~~SRTT16~~" means the ASTM F 2493-08, Standard Specification for a Radial Standard Reference Test Tire P225/60R16.
- 2.8160. "Temporary use spare tyre" means a tyre different from a tyre fitted to a vehicle for normal driving conditions, and intended only for temporary use under restricted driving conditions;
- 2.8264. "Test rim" means the rim on which a tyre is fitted for testing and which may be any rim listed in industry standards as appropriate for use with that tyre;
- 2.83. "~~Test run~~" means a single pass of a loaded tyre over a given test track surface;
- 2.84. "~~Test tyre(s)~~" means a candidate tyre, a reference tyre or a control tyre or tyre set that is used in a test run;
- 2.8562. "Theoretical rim" means a rim width calculated by multiplying the nominal section width by a specific, industry standardized, coefficient depending upon the aspect ratio of the tyre;
- 3.86. "~~Traction test~~" means a series of a specified number of spin-traction test runs according to ASTM standard F1805-06 of the same tyre repeated within a short time frame;
- 2.8763. "Traction tyre" means a tyre in Class C2 or C3 bearing the inscription TRACTION and intended to be fitted primarily to the drive axle(s) of a vehicle to maximize force transmission in various circumstances;
- In order to be classified as a "traction tyre", a tyre is required to meet at least one of the following conditions:**
- The tyre shall have a tread pattern with minimum two circumferential ribs, each containing a minimum of 30 block-like elements, separated by grooves and/or sipe elements the depth of which has to be minimum of one half of the tread depth.**
- 2.8864. "Tread" means that part of a tyre that comes into contact with the road;

Comment [JN27]: Revision 2 – Amendment 1
Supplement 1 to the 02 series of amendments of Reg. 117- Date of entry into force: 18 November 2012
WP.29/2012/2

Comment [JN28]: Proposal for Supplement 7 to the 02 series of amendments to Regulation No. 117
WP.29/2015/5

Comment [JN29]: Annex 5 of Reg. 117 – paragraph 2.12
Revision 2 – Amendment 1
Supplement 1 to the 02 series of amendments of Reg. 117- Date of entry into force: 18 November 2012
WP.29/2012/2

Comment [JN30]: Annex 5 of Reg. 117 – paragraph 2.13
Revision 2 – Amendment 1
Supplement 1 to the 02 series of amendments of Reg. 117- Date of entry into force: 18 November 2012
WP.29/2012/2

Comment [JN31]: Annex 5 of Reg. 117 – paragraph 2.1
Revision 2 – Amendment 1
Supplement 1 to the 02 series of amendments of Reg. 117- Date of entry into force: 18 November 2012
WP.29/2012/2

Comment [JN32]: Annex 5 of Reg. 117 – paragraph 2.2
Revision 2 – Amendment 1
Supplement 1 to the 02 series of amendments of Reg. 117- Date of entry into force: 18 November 2012
WP.29/2012/2

Comment [JN33]: Annex 7 of Reg. 117 paragraph 1.3.
Revision 2 - Amendment 2
Supplement 2 to the 02 series of amendments – Date of entry into force: 15 July 2013
WP.29/2012/54

Comment [JN34]: Paragraph 6.5. and 6.5.1.of Reg. 117

- 2.8965. "**Tread pattern groove**" means the space between two adjacent ribs or blocks in the tread pattern;
- 2.90. "**Tread depth**" means the depth of the principal grooves;
- 2.9166. "Tread pattern" means the geometric arrangement of blocks, ribs and grooves of the tread;
- 2.9267. "Tread separation" means the pulling away of the tread from the tyre carcass;
- 2.9368. "Tread Wear Indicators (TWI)" means the projections within the principal grooves designed to give a visual indication of the wear of the tread;
- 2.9469. "Tubeless tyre" means a tyre specifically designed for fitting to appropriate wheel rims without an inner tube;
- 2.9570. "T-type temporary use spare tyre" means a type of temporary use spare tyre designed for use at inflation pressures higher than those established for standard and ~~reinforced~~ extra load tyres;
- 2.9671. "Tyre size designation" means a combination of letters, numbers and symbols which uniquely identify the size and structure of the tyre as set out in one of the standards of the organizations listed in Annex ~~710~~ or in the tables in Annex ~~67~~ to this regulation.
- 2.97. "**Tyre test vehicle**" means a dedicated special purpose vehicle which has instruments to measure the vertical and the longitudinal forces on one test tyre during braking;
- 2.98. "**Vertical load**" means the load in newton imposed on the tyre perpendicular to the road surface;
- 2.99. "**Void to fill ratio**" means the ratio between the area of voids in a reference surface and the area of this reference surface calculated from the mould drawing;
- 2.100. "**Wet grip index ("G")**" means the ratio between the performance of the candidate tyre and the performance of the standard reference test tyre;

3. Requirements

- 3.1. Plant codes
- 3.1.1. Plant code registration for manufacturers with a representative in the United States of America
- 3.1.1.1. Each tyre manufacturer of new pneumatic tyres shall apply in writing to the following address for registration and allocation of a manufacturer plant code identification symbol:
- Office of Vehicle Safety Compliance
National Highway Traffic Safety Administration
1200 New Jersey Avenue, SE
Washington, D.C. 20590, United States of America
- 3.1.1.2. The tyre manufacturer requesting a plant code assignment shall identify itself as the tyre manufacturer and declare the following information in the application and shall inform the NHTSA of any changes to the information:

Comment [JN35]: Revision 3 – Amendment 3 of Reg. 30
Supplement 17 to the 02 series of amendments - Date of entry into force: 27 January 2013
Document ECE/TRANS/WP.29/2012/48 as amended by para. 50 of the report 157th session June 2012.

Comment [JN36]: Paragraph 2.14 of Reg. 117

Comment [JN37]: Annex 5 of Reg. 117 paragraph 2.11.
Revision 2 – Amendment 1
Supplement 1 to the 02 series of amendments - Date of entry into force: 18 November 2012
WP.29/2012/2

Comment [JN38]: Annex 5 of Reg. 117 paragraph 2.10.
Revision 2 – Amendment 1
Supplement 1 to the 02 series of amendments - Date of entry into force: 18 November 2012
WP.29/2012/2

Comment [JN39]: Revision 3 – Amendment 3 of Reg. 30
Supplement 17 to the 02 series of amendments - Date of entry into force: 27 January 2013
Document ECE/TRANS/WP.29/2012/48 as amended by para. 50 of the report 157th session June 2012.
and
Revision 3 of Reg. 54
Supplement 18 to the original version of the Regulation - Date of entry into force: 27 January 2013
ECE/TRANS/WP.29/2012/49

Comment [JN40]: Paragraph 2.17.4. of Reg. 117

- 3.1.1.3. The name or other designation identifying the applicant, and its main office address;
- 3.1.1.4. The name, or other identifying designation, of each individual plant operated by the manufacturer and the address of each plant, if applicable;
- 3.1.1.5. The type of tyres manufactured at each plant, e.g., pneumatic tyres for passenger cars, buses, trucks or motorcycles; pneumatic retreaded tyres; or non-pneumatic retreaded tyres; or non-pneumatic tyre assemblies.
- 3.1.2. Plant code for manufacturers with no specified representative in the United States of America
 - 3.1.2.1. The plant code for tyres manufactured by companies with no specified representative in the United States of America will be 999.
- 3.2. Marking
 - 3.2.1. The Tyre Identification Number is a series of numbers, letters and spaces in the format **YYY_MMMMMM~~MM~~ DDDD**.
 - 3.2.1.1. The YYY is a 3 digit universal plant code for the place of manufacture of the tyre.
 - 3.2.1.2. The **MMMMMM~~MM~~** is a **8-6** digit manufacturer's code. Within the tyre identification number format, this will be an **8-6** digit required field, but the content is up to the tyre manufacturer.
 - 3.2.1.3. The DDDD with 4 digits represents the week and year of manufacture, also known as the date code. The first two symbols shall identify the week of the year by using "01" for the first full calendar week in each year, "02" for the second full calendar week, and so on. The calendar week runs from Sunday through the following Saturday. The final week of each year shall include not more than 6 days of the following year. The third and fourth symbols shall identify the year. Example: 0110 means the first week of 2010.
 - ~~3.2.1.4. The " _ " is a space of not less than 6 mm or greater than 19 mm.~~
 - 3.2.1.45. The Tyre Identification Number shall be located on the intended outboard sidewall of the tyre, and positioned between the bead and 50 per cent of the distance from the bead to the tread. On the other sidewall of the tyre either a tyre identification number or a partial tyre identification number is required. The partial tyre identification number is comprised of all characters except the date code. If the tyre has no intended outboard sidewall, the complete tyre identification number shall be placed on one sidewall, and a partial or complete tyre identification number shall be placed on the other sidewall.
 - 3.2.1.56. The symbols to be used in the tyre identification number format are A, B, C, D, E, F, H, J, K, L, M, N, P, R, T, U, V, W, X, Y, 1, 2, 3, 4, 5, 6, 7, 8, 9, 0.
 - 3.2.1.67. The symbols that shall not be used are G, I, O, Q, S, and Z.
 - 3.2.1.78. The font to be used for the Tyre Identification Number shall be Futura Bold, Modified Condensed, Gothic, or OCR-B (as defined in ISO 1073-2: 1976).
 - 3.2.1.89. The characters shall have a height of at least 6 mm and a positive or negative relief of between 0.5 to 1.0 mm, as measured from the surface in the immediate vicinity of the marking.
 - 3.3. Other sidewall markings

Comment [JN41]:
 Washington, D.C. - The National Highway Traffic Safety Administration (NHTSA) published a final rule to standardize the Tire Identification Number (TIN) imprinted on tires sold in the U.S. The new regulation creates a 13 digit TIN for new tires and seven digit TIN for retreaded truck tires.

Comment [JN42]: TIN Requirements – RMA recommends striking 3.2.1.4, which provides that “The ‘ _ ’ is a space of not less than 6 mm or greater than 19 mm.” The NHTSA final rule does not contain spacing requirements for between the various TIN sections. The final rule only provides spacing requirements for the space between the “DOT” mark and the TIN. The GTR does not discuss the “DOT” mark.

- 3.3.1. Unless otherwise stated in this gtr, the following information, together with any other markings required by provisions in annexes to this regulation, shall be legibly and permanently moulded into or onto the sidewall(s):
- 3.3.1.1. in the case of asymmetric tyres on the intended outboard sidewall as viewed when the tyre is fitted to the vehicle;
- 3.3.1.2. In either case, on at least one sidewall, the required markings shall be in a position on the sidewall where they are least susceptible to being "scrubbed" away during use;
- 3.3.1.2.1. The brand name or the trade name or trade mark, in characters not less than 4 mm high;
- 3.3.1.2.2. The country of manufacture in characters not less than 2 mm high;
- 3.3.1.2.3. The tyre size designation in characters not less than 6 mm high comprising:
- 3.3.1.2.3.1. An indication of the tyre structure;
- 3.3.1.2.3.1.1. R for radial construction;
- 3.3.1.2.3.1.2. RF for radial run flat tyre;
- 3.3.1.2.3.2. The service description (load index and speed symbol);
- 3.3.1.2.3.3. An identification of the tyre to rim fitment configuration when it differs from the standard configuration.
- 3.3.1.2.3.3.1. In the case of LT and C type tyres, the words "Load Range" or "LR" followed by the letter designating the tyre load range "B, C, D, or E".
- 3.3.2. Each tyre shall be labelled on the other side (from that directed in paragraph 3.2.1.45. above) with the same tyre identification number except for the date code and, at the discretion of the manufacturer, any optional code on the other sidewall.
- 3.3.3. For tyres suitable for speed in excess of 300 km/h, the letter "R" placed in front of the rim diameter code symbol marking shall be replaced by "ZR" and the tyre shall be marked, in parentheses, with a service description consisting of the speed symbol "Y" and a corresponding load index, for example, 245/45ZR17 (95 Y).
- Note:* The actual maximum tyre load capacity and speed capability shall be stated in the tyre manufacturer's technical literature and made available to the public.
- 3.3.4. For passenger car tyres, each tyre shall be labelled with its maximum permissible inflation pressure in kPa (psi) and shall be labelled with its maximum load rating in kilograms (lbs).
- 3.3.5. In the case of LT or C type tyres, the maximum load rating and corresponding inflation pressure of the tyre, shown as follows:
- "Max load single ___ kg (___ lb) at ___ kPa (___ psi) cold";
- "Max load dual ___ kg (___ lb) at ___ kPa (___ psi) cold".
- For LT and C type tyres rated for single fitment only, mark as follows:
- "Max load ___ kg (___ lb) at ___ kPa (___ psi) cold".

- 3.3.6. The inscription "EXTRA LOAD" or "XL" for extra load tyres, or the inscription "LL" or "LIGHT LOAD" for light load tyres, if applicable, in characters not less than 4 mm high;
- 3.3.7. The word "TUBETYPE", if applicable, in characters not less than 4 mm high;
- 3.3.8. The inscription "M+S", "M.S.", "M&S", "M-S", or "M/S", in characters not less than 4 mm high, if the tyre is a snow tyre.

3.3.9. The **"Alpine" symbol ("3-peak-mountain with snowflake")** ~~three peaked mountain snowflake symbol~~ which identifies a snow tyre **classified as "snow tyre for use in severe snow conditions" that is an M+S marked snow tyre, and is also intended for use in severe snow conditions, and meets snow performance requirements.** The symbol shall have a minimum base of 15 mm and a minimum height of 15 mm and shall contain three peaks with the middle peak being the tallest. Inside the mountain, there shall be a six-sided snowflake having a minimum height of one-half the tallest peak. An example is shown below, and is to be placed adjacent to ~~the M+S type designation~~ **an inscription as listed in paragraph 3.3.8.**

Comment [JN43]: Revision 2 - Amendment 2
 Supplement 2 to the 02 series of amendments of reg. 117 – Date of entry into force: 15 July 2013
 WP.29/2012/54 Amended by ECE/TRANS/WP.29/1099

Comment [JN44]: Agreed during GRRF 80th session following a proposal from Canada.

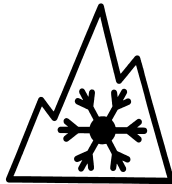

3.3.10. The symbol below if the tyre is a "run flat" or "self-supporting" tyre, and performance requirements for run flat tyres are met as per paragraph 3.13., where "h" is at least 12 mm.

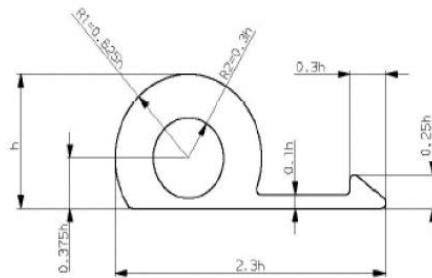

- 3.3.11. In the case of LT or C type tyres, an indication, by the "PSI" index, of the inflation pressure to be adopted for the load/speed endurance tests. A table showing the relationship among "PSI" and "kPa" units is listed in Annex 4.
- 3.3.12. In the case of LT or C type tyres **classified as "traction tyre"**, the inscription "TRACTION" ~~for "Traction tyres";~~
- 3.3.13. In the case of LT or C type tyres, the inscription "ET" or "ML" or "MPT" **and / or "POR"** for "Special use tyres".

Comment [JN45]: Revision 3 of Reg. 54
 Supplement 18 to the original version of the Regulation - Date of entry into force: 27 January 2013
 ECE/TRANS/WP.29/2012/49

- 3.3.13.1. ET = Extra Tread;
- 3.3.13.2. ML = Mining and Logging tyre used in intermittent highway service;
- 3.3.13.3. MPT = Multi-Purpose Truck tyres.
- 3.3.13.4. POR = Professional Off-Road tyres.**
- 3.3.14. In the case of LT or C type tyres, the prefix "LT" before the tyre size designation, or the suffix "C" or "LT" after the rim diameter marking referred to in Annex 3, and, if applicable, after the tyre to rim fitment configuration referred to in paragraph 3.3.1.2.3.3.
- 3.3.15. In the case of LT or C type tyres, the suffix "CP" after the rim diameter marking referred to in Annex 3 and, if applicable, after the tyre to rim fitment configuration referred to in paragraph 3.3.1.2.3.3. This marking is mandatory in the case of tyres fitted on 5° drop centre rims, having a load index in single **operation** lower or equal to 121 and specifically designed for the equipment of motor caravans.
- 3.4. Tread wear indicators
- 3.4.1. Except as noted below, each passenger tyre and each LT/C tyre shall have at least six transverse rows of tread wear indicators, approximately equally spaced around the circumference of the tyre and situated in the principal grooves of the tread.
- 3.4.2. For passenger car tyres designed for mounting on rims of nominal rim diameter code 12 or less, not less than three transverse rows of tread wear indicators is acceptable.
- 3.4.3. The height of each tread wear indicator shall be 1.6 mm, + 0.6 - 0.0 mm.
- 3.5. Physical dimensions of passenger car tyres
- 3.5.1. The following paragraphs describe in detail the requirements for determining the physical dimensions of pneumatic tyres according to this regulation. The characteristics to be determined are the overall width, and the outside diameter. If these characteristics are within the specified tolerances, the physical dimensions of the tyre are acceptable.
- 3.5.2. Definitions (see paragraph 2. of this regulation for detailed definitions of various terms)
- 3.5.2.1. The overall width of the tyre is defined as the average of four measurements of its width at the widest point, including any markings or protective ribs.
- 3.5.2.2. There is no defined theoretical overall width of standard tyres. It is a measured characteristic, not a calculated one.
- 3.5.3. The theoretical section width shall be calculated by the following formula:
- $$S = S_1 + K(A - A_1),$$
- Where:
- S is the theoretical section width expressed in mm;
- S_1 is the nominal section width (in mm) as shown on the side wall of the tyre in the designation of the tyre as prescribed;

A is the width (expressed in mm) of the measuring rim, as declared by the manufacturer;⁷

A₁ is the width (expressed in mm) of the theoretical rim.

A₁ shall be taken to equal S₁ multiplied by the factor x, as specified in the international standard ISO 4000-1, and K shall be taken to equal 0.4.

3.5.4. Outer diameter of tyre

The outer diameter of the tyre shall be calculated by the following formula:

$$D = d + 2H$$

Where:

D is the outer diameter in millimetres,

d is the rim diameter in millimetres;⁸

H is the nominal section height in millimetres, equal to:

$$H = 0.01 S_1 R_a$$

S₁ is the nominal section width in millimetres, and R_a is the nominal aspect ratio, all as shown on the sidewall of the tyre in the tyre size designation.

3.5.5. Physical dimensions measurement method

3.5.5.1. Mount the tyre on one of the approved rims mentioned in the appropriate Standards Manual.

3.5.5.2. Adjust the pressure to that specified in the table below:

Physical dimensions test tyre inflation pressures	Tyre application	Test pressure (kPa)
	Standard load, light load	180
	Extra load	220

3.5.5.3. Condition the tyre, mounted on its rim, at the ambient room temperature between 18 °C and 38 °C for not less than 24 hours.

3.5.5.4. Re-adjust the pressure to that specified in the table above.

3.5.5.5. Measure the overall width at four equally spaced points around the tyre, taking the thickness of protective ribs or bands into account. The reported value will be the average of the four measurements rounded to the nearest millimetre.

3.5.5.6. Determine the outer diameter by measuring the maximum circumference, dividing the result by 3.1416 (Pi) and rounding to the nearest millimetre.

3.5.5.7. Determine the height of the tread wear indicators by measuring the difference between the total depth of the tread pattern groove in the vicinity of the tread wear indicator and the depth to the top of the tread wear indicator. Repeat this measurement for at least one tread wear indicator in each row (minimum of 6 or 3, depending on the rim diameter; a row is the linear sequence of tread

⁷ When the conventional number is given by codes, the value in millimetres is obtained by multiplying the code number by 25.4.

⁸ When the conventional number is given by codes, the value in millimetres is obtained from Annex 3.

Comment [JN46]: Revision 3 – Amendment 3 of Reg. 30
 Supplement 17 to the 02 series of amendments - Date of entry into force: 27 January 2013
 Document ECE/TRANS/WP29/2012/48 as amended by para. 50 of the report 157th session June 2012.

wear indicators positioned radially across the tread from one side to the other). At least one tread wear indicator in each principal groove shall be measured (the principal grooves are the wide grooves positioned circumferentially around the tread). Record all of the individual values rounded to the nearest tenth of a millimetre.

3.5.6. Physical dimension requirements

3.5.6.1. Overall width

3.5.6.1.1. The tyre overall width may exceed the theoretical section width defined in paragraph 3.5.3. above by 4 per cent.

3.5.6.1.2. In addition, if the tyre has rim protectors (see definition in paragraph 2.), the figure as increased by the above tolerance may be exceeded by 8 mm.

3.5.6.2. Outer diameter

3.5.6.2.1. The outer diameter of a tyre shall not be outside the values D_{min} and D_{max} obtained from the following formulae:

$$D_{min} = d + (2H a)$$

$$D_{max} = d + (2H b)$$

Where the coefficients "a" and "b" are:

coefficient "a" = 0.97

coefficient "b" = 1.04 for normal (road type) and 1.06 for special use tyres

For snow tyres the maximum overall diameter (D_{max}) may be exceeded by 1 per cent.

3.5.7. Figure 1: Drawing of normal tyre showing rim diameter (d), outside diameter (D), section height (H) and section width (S) and the rim width (A).

Figure 1

Drawing of a normal tyre showing various dimensions

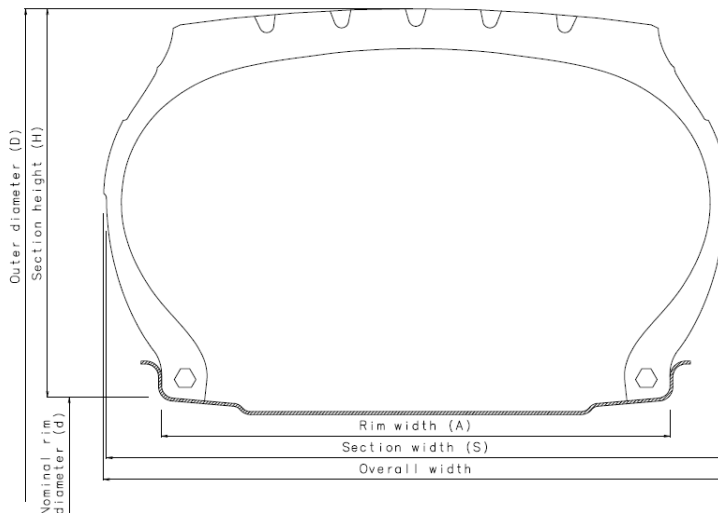

3.5.8. For other tyre sizes for which dimensions cannot be calculated, the dimensions including allowance for growth in service, shall comply with those given in standards publications of the organizations listed in Annex 7+0 and which were current either at the date of manufacture of the tyre or at any later date.

3.6. Strength test for passenger car tyres

3.6.1. Each tyre shall meet the requirements for minimum breaking energy specified in the table below.

Nominal section width	Units	Standard load or light load tyres	Extra load tyres
Below 160 mm	Joules	220	441
	Inch-pounds	1950	3900
160 mm or above	Joules	294	588
	Inch-pounds	2600	5200

3.6.2. Strength test procedure

3.6.2.1. Mount the tyre on a test rim and inflate it to the test inflation pressure specified in the table below:

Strength test tyre inflation pressures	Tyre application	Test pressure (kPa)
	Standard load, light load	180
	Extra load	220

3.6.2.2. Condition the wheel and tyre assembly for at least three hours at the temperature of the test room;

3.6.2.3. Re-adjust the tyre pressure to that specified in the previous table above (paragraph 3.6.2.1.);

3.6.2.4. Force a 19 mm (3/4 inch) diameter cylindrical steel plunger with a hemispherical end perpendicularly into the tread rib as near to the centerline as possible, avoiding penetration into the tread pattern groove, at the rate of 50 mm (2 inches) per minute;

3.6.2.5. Record the force and penetration at five test points equally spaced around the circumference of the tyre. If the tyre fails to break before the plunger is stopped by reaching the rim, record the force and penetration as the rim is reached and use these values in paragraph 3.6.2.6.

3.6.2.6. The breaking energy, W, in Joules, shall be calculated from:

$$W = ((F P)/2) 10^{-3}$$

Where:

W = Energy in Joules

F = Force in Newtons applied to the plunger

P = Penetration of the plunger in mm

or

Comment [JN47]: Revision 3 – Amendment 3 of Reg. 30
Supplement 17 to the 02 series of amendments - Date of entry into force: 27 January 2013
Document ECE/TRANS/WP29/2012/48 as amended by para. 50 of the report 157th session June 2012.

$$W = (F P)/2$$

Where:

W = Energy in inch-pounds

F = Force in pounds and

P = Penetration in inches.

- 3.6.2.7. Determine the breaking energy value for the tyre by computing the average of the five values obtained.
- 3.6.2.8. In the case of tubeless tyres, an inner tube may be provided to ensure the retention of the inflation pressure throughout the test provided that such inner tube does not adversely affect the test.
- 3.7. Tubeless tyre bead unseating resistance test for passenger car tyres
- 3.7.1. Requirements
- 3.7.1.1. Each tubeless tyre shall meet the requirements for minimum force, in Newtons, for bead unseating resistance, specified in one of the tables below.
- 3.7.1.2. For tubeless radial ply tyres the applied force required to unseat the tyre bead at the point of contact, in relation to the nominal section width of the tyre, shall not be less than:

<i>Nominal section width (mm)</i>	<i>Minimum force (N)</i>
Less than 160	6 670
From 160 to 204	8 890
Equal to or greater than 205	11 120

<i>Nominal section width (code)</i>	<i>Minimum force (N)</i>
Less than 6.00	6 670
From 6.00 to 7.99	8 890
Equal to or greater than 8.00	11 120

- 3.7.2. Preparation of tyre
- 3.7.2.1. Wash the tyre and dry it at the beads. Mount it without lubricant or adhesive on a clean, painted test rim. The rim contour shall be one of those specified for the fitment of the test tyre.
- 3.7.2.2. Inflate the tyre to the pressure specified in the table shown below:

<i>Bead unseating resistance test pressures</i>	<i>Tyre application</i>	<i>Test pressure kPa</i>
	Standard load, light load	180
	Extra load	220

- 3.7.3. Test procedure
- 3.7.3.1. Mount the assembly on a fixture as shown in Figure 2, below, and force the bead unseating block shown in Figure 3 or Figure 4 against the tyre sidewall as required by the geometry of the fixture.
- 3.7.3.2. Position the bead unseating block against the tyre sidewall at a horizontal distance "A" as shown in Figure 2 and Table 1, below.
- 3.7.3.3. Apply a force through the block to the tyre outer sidewall at a rate of 50 mm/min \pm 2.5 mm/min.
- 3.7.3.4. Increase the force until the bead unseats or until the prescribed value shown in paragraph 3.7.1.2. is reached.
- 3.7.3.5. Repeat the test at least four times at places approximately equally spaced around the tyre circumference.

Figure 2
Bead unseating fixture

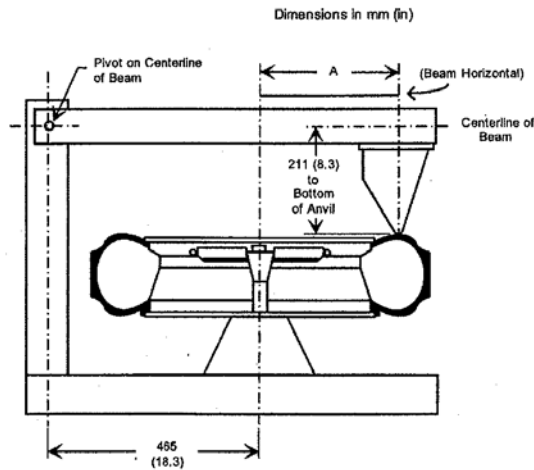

Table 1
List of "A" dimensions

<i>Table of A dimension for different rim codes</i>		
<i>Rim code</i>	<i>mm</i>	<i>Inches</i>
20	345	13.50
19	330	13.00
18	318	12.50
17	305	12.00
16	292	11.50
15	279	11.00
14	267	10.50

Table of A dimension for different rim codes		
Rim code	mm	Inches
13	254	10.00
12	241	9.50
11	229	9.00
10	216	8.50
320	216	8.50
340	229	9.00
345	235	9.25
365	248	9.75
370	254	10.00
390	279	11.00
415	292	11.50

Figure 3
Bead unseating block

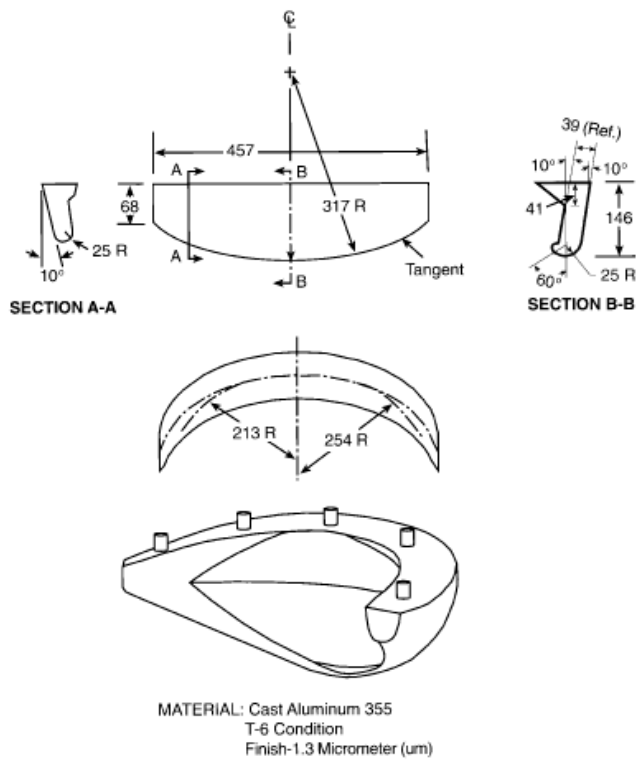
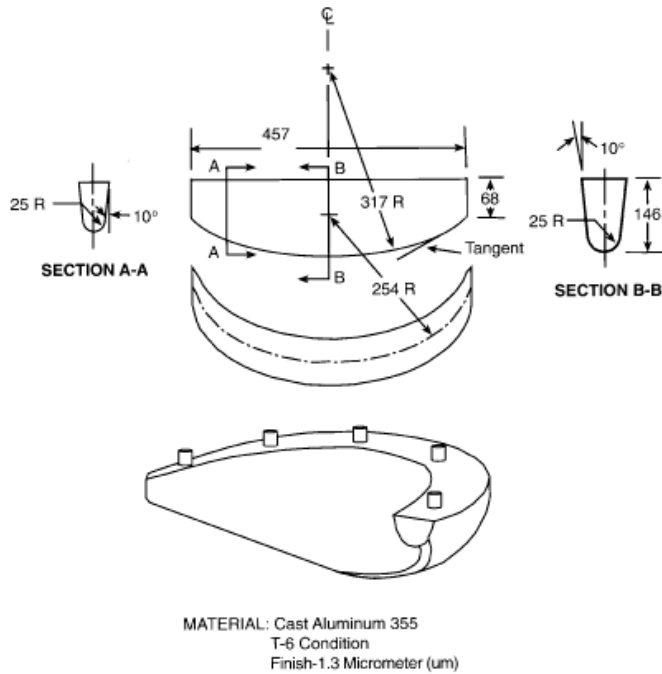

Figure 4
Bead unseating block



3.8. Tyre rolling sound emission test

3.8.1. Requirements

For tyres which are included within the scope of this regulation, except **Professional off-road tyres, tyres fitted with additional devices to improve traction properties (e.g. studded tyres), tyres with a speed rating less than 80 km/h (speed symbol F) and those having a nominal rim diameter code ≤ 10 (or ≤ 254 mm) or ≥ 25 (or ≥ 635 mm) with rim diameter code greater than or equal to 25 (635 mm)**, the rolling sound emission value shall not exceed the values given below for tyres of Classes C1, C2 and C3, with reference to the categories of use and, where relevant, the nominal section widths, given in the definitions section in paragraph 2. of this regulation.

Class C1 tyres

Nominal section width	Limit dB(A)
185 and lower	70
Over 185 up to 245	71
Over 245 up to 275	72
Over 275	74

<i>Nominal section width</i>	<i>Limit dB(A)</i>
The above limits shall be increased by 1 dB(A) for snow tyres for use in severe snow conditions, extra load tyres or any combination of these classifications.	

Class C2 tyres

<i>Category of use</i>		<i>Limit dB(A)</i>	
		<i>Other</i>	<i>Traction tyres</i>
Normal tyre		72	73
Snow tyre		72	73
	Snow tyre for use in severe snow conditions	73	75
Special use tyre		74	75

Class C3 tyres

<i>Category of use</i>		<i>Limit dB(A)</i>	
		<i>Other</i>	<i>Traction tyres</i>
Normal tyre		73	75
Snow tyre		73	75
	Snow tyre for use in severe snow conditions	74	76
Special use tyre		75	77

3.8.2. Coast-by test method for measuring tyre rolling sound emission

The presented method contains specifications on measuring instruments, measurement conditions and the measurement method, in order to obtain the sound level of a set of tyres mounted on a test vehicle rolling on a specified road surface. The maximum sound pressure level is to be recorded, when the test vehicle is coasting, by remote-field microphones; the final result for a reference speed is obtained from a linear regression analysis. Such test results cannot be related to tyre rolling sound measured during acceleration under power or deceleration under braking.

3.8.3. Measuring instruments

3.8.3.1. Acoustic measurements

The sound level meter or the equivalent measuring system, including the windscreen recommended by the manufacturer shall meet or exceed the requirements of Type 1 instruments in accordance with standard IEC 60651: 1979/A1:1993, second edition.

The measurements shall be made using the frequency weighting A, and the time weighting F.

When using a system that includes a periodic monitoring of the A-weighted sound level, a reading should be made at a time interval not greater than 30 ms.

3.8.3.1.1. Calibration

At the beginning and at the end of every measurement session, the entire measurement system shall be checked by means of a sound calibrator that fulfils the requirements for sound calibrators of at least precision Class 1 according to standard IEC 60942:1988.

Without any further adjustment the difference between the readings of two consecutive checks shall be less than or equal to 0.5 dB(A). If this value is exceeded, the results of the measurements obtained after the previous satisfactory check shall be discarded.

3.8.3.1.2. Compliance with requirements

The compliance of the sound calibration device with the requirements of standard IEC 60942:1988 shall be verified once a year and the compliance of the instrumentation system with the requirements of standard IEC 60651:1979/A1:1993, second edition shall be verified at least every two years, by a laboratory which is authorized to perform calibrations traceable to the appropriate standards.

3.8.3.1.3. Positioning of the microphone

The microphone (or microphones) shall be located at a distance of 7.5 ± 0.05 m from track reference line CC' (Figure 5) and 1.2 ± 0.02 m above the ground. Its axis of maximum sensitivity shall be horizontal and perpendicular to the path of the vehicle (line CC').

3.8.3.2. Speed measurements

The vehicle speed shall be measured with instruments with accuracy of ± 1 km/h or better when the front end of the vehicle has reached line PP' (Figure 5).

3.8.3.3. Temperature measurements

Measurements of air as well as test surface temperature are mandatory.

The temperature measuring devices shall be accurate within $\pm 1^\circ\text{C}$.

3.8.3.3.1. Air temperature

The temperature sensor is to be positioned in an unobstructed location close to the microphone in such a way that it is exposed to the airflow and protected from direct solar radiation. The latter may be achieved by any shading screen or similar device. The sensor should be positioned at a height of 1.2 ± 0.1 m above the test surface level, to minimize the influence of the test surface thermal radiation at low airflows.

3.8.3.3.2. Test surface temperature

The temperature sensor is to be positioned in a location where the temperature measured is representative of the temperature in the wheel tracks, without interfering with the sound measurement.

If an instrument with a contact temperature sensor is used, heat-conductive paste shall be applied between the surface and the sensor to ensure adequate thermal contact.

If a radiation thermometer (pyrometer) is used, the height should be chosen to ensure that a measuring spot with a diameter of ≥ 0.1 m is covered.

- 3.8.3.4. Wind measurement
The device shall be capable of measuring the wind speed with a tolerance of ± 1 m/s. The wind shall be measured at microphone height. The wind direction with reference to the driving direction shall be recorded.
- 3.8.4. Conditions of measurement
- 3.8.4.1. Test site
The test site shall consist of a central section surrounded by a substantially flat test area. The measuring section shall be level; the test surface shall be dry and clean for all measurements. The test surface shall not be artificially cooled during or prior the testing.
The test track shall be such that the conditions of a free sound field between the sound source and the microphone are attained to within 1 dB(A). These conditions shall be deemed to be met if there is no large sound reflecting objects such as fences, rocks, bridges or building within 50 m of the centre of the measuring section. The surface of the test track and the dimensions of the test site shall be in accordance with ~~Annex 6 to this regulation~~ **ISO 10844:2014**.
- A central part of at least 10 m radius shall be free of powdery snow, tall grass, loose soil, cinders or the like. There shall be no obstacle, which could affect the sound field within the vicinity of the microphone and no persons shall stand between the microphone and the sound source. The operator carrying out the measurements and any observers attending the measurements shall position themselves so as not to affect the readings of the measuring instruments.
- 3.8.4.2. Meteorological conditions
Measurements shall not be made under poor atmospheric conditions. It shall be ensured that the results are not affected by gusts of wind. Testing shall not be performed if the wind speed at the microphone height exceeds 5 m/s.
Measurements shall not be made if the air temperature is below 5 °C or above 40 °C or the test surface temperature is below 5 °C or above 50 °C.
- 3.8.4.3. Ambient noise
- 3.8.4.3.1. The background sound level (including any wind noise) shall be at least 10 dB(A) less than the measured tyre rolling sound emission. A suitable windscreen may be fitted to the microphone provided that account is taken of its effect on the sensitivity and directional characteristics of the microphone.
- 3.8.4.3.2. Any measurement affected by a sound peak which appears to be unrelated to the characteristics of the general sound level of tyres, shall be ignored.
- 3.8.4.4. Test vehicle requirements
- 3.8.4.4.1. General
The test vehicle shall be a motor vehicle and be fitted with four single tyres on just two axles.
- 3.8.4.4.2. Vehicle load
The vehicle shall be loaded such as to comply with the test tyre loads as specified in paragraph 3.8.4.5.2. below.

Comment [JN48]:
Supplement 4 to the 02 series of amendments- Date of entry into force: 13 February 2014
WP.29/2013/55
And
Proposal for Supplement 8 to the 02 series of amendments to Regulation No. 117 (Tyre rolling resistance, rolling noise and wet grip)
ECE/TRANS/WP.29/2015/65

3.8.4.4.3. Wheelbase

The wheelbase between the two axles fitted with the test tyres shall for Class C1 be less than 3.50 m and for Class C2 and Class C3 tyres be less than 5 m.

3.8.4.4.4. Measures to minimize vehicle influence on sound level measurements

To ensure that tyre rolling sound is not significantly affected by the test vehicle design the following requirements and recommendations are given.

3.8.4.4.4.1. Requirements:

- (a) Spray suppression flaps or other extra device to suppress spray shall not be fitted;
- (b) Addition or retention of elements in the immediate vicinity of the rims and tyres, which may screen the emitted sound, is not permitted;
- (c) Wheel alignment (toe in, camber and caster) shall be in full accordance with the vehicle manufacturer's recommendations;
- (d) Additional sound absorbing material may not be mounted in the wheel housings or under the underbody;
- (e) Suspension shall be in such a condition that it does not result in an abnormal reduction in ground clearance when the vehicle is loaded in accordance with the testing requirement. If available, body level regulation systems shall be adjusted to give a ground clearance during testing which is normal for unladen condition.

3.8.4.4.4.2. Recommendations to avoid parasitic noise:

- (a) Removal or modification on the vehicle that may contribute to the background noise of the vehicle is recommended. Any removals or modifications shall be recorded in the test report;
- (b) During testing it should be ascertained that brakes are not poorly released, causing brake noise;
- (c) It should be ascertained that electric cooling fans are not operating;
- (d) Windows and sliding roof of the vehicle shall be closed during testing.

3.8.4.5. Tyres

3.8.4.5.1. General

Four identical tyres shall be fitted on the test vehicle. In the case of tyres with a load index in excess of 121 and without any dual fitting indication, two of these tyres of the same type and range shall be fitted to the rear axle of the test vehicle; the front axle shall be fitted with tyres of size suitable for the axle load and planed down to the minimum depth in order to minimize the influence of tyre/road contact noise while maintaining a sufficient level of safety. Winter tyres that in certain Contracting Parties may be equipped with studs intended to enhance friction shall be tested without this equipment. Tyres with special fitting requirements shall be tested in accordance with these requirements (e.g. rotation direction). The tyres shall have full tread depth before being run-in.

Tyres are to be tested on rims permitted by the tyre manufacturer.

3.8.4.5.2. Tyre loads

The test load Q_t for each tyre on the test vehicle shall be 50 to 90 per cent of the reference load Q_r , but the average test load $Q_{t,avr}$ of all tyres shall be 75 ± 5 per cent of the reference load Q_r .

For all tyres the reference load Q_r corresponds to the maximum mass associated with the load index of the tyre. In the case where the load index is constituted by two numbers divided by a slash (/), reference shall be made to the first number.

3.8.4.5.3. Tyre inflation pressure

Each tyre fitted on the test vehicle shall have a test pressure P_t not higher than the reference pressure P_r and within the interval:

$$P_r \cdot \left(\frac{Q_t}{Q_r} \right)^{1.25} \leq P_t \leq 1.1 P_r \cdot \left(\frac{Q_t}{Q_r} \right)^{1.25}$$

For Class C2 and Class C3 the reference pressure P_r is the pressure corresponding to the pressure index marked on the sidewall.

For Class C1 the reference pressure is $P_r = 250$ kPa for "standard" or "light load" tyres and 290 kPa for "extra load" tyres; the minimum test pressure shall be $P_t = 150$ kPa.

3.8.4.5.4. Preparations prior to testing

The tyres shall be "run-in" prior to testing to remove compound nodules or other tyre pattern characteristics resulting from the moulding process. This will normally require the equivalent of about 100 km of normal use on the road.

The tyres fitted to the test vehicle shall rotate in the same direction as when they were run-in.

Prior to testing tyres shall be warmed up by running under test conditions.

3.8.5. Method of testing

3.8.5.1. General conditions

For all measurements the vehicle shall be driven in a straight line over the measuring section (AA' to BB') in such a way that the median longitudinal plane of the vehicle is as close as possible to the line CC'.

When the front end of the test vehicle has reached the line AA', the vehicle's driver shall have put the gear selector on neutral position and switched off the engine. If abnormal noise (e.g. ventilator, self-ignition) is emitted by the test vehicle during the measurement, the test shall be disregarded.

3.8.5.2. Nature and number of measurements

The maximum sound level expressed in A-weighted decibels (dB(A)) shall be measured to the first decimal place as the vehicle is coasting between lines AA' and BB' (Figure 5 - front end of the vehicle on line AA', rear end of the vehicle on line BB'). This value will constitute the result of the measurement.

At least four measurements shall be made on each side of the test vehicle at test speeds lower than the reference speed specified in paragraph 3.8.6.1. and at least four measurements at test speeds higher than the reference speed. The speeds shall be approximately equally spaced over the speed range specified in paragraph 3.8.5.3.

3.8.5.3. Test speed range

The test vehicle speeds shall be within the range:

- (a) From 70 to 90 km/h for Class C1 and Class C2 tyres;
- (b) From 60 to 80 km/h for Class C3 tyres.

3.8.6. Interpretation of results

The measurement shall be invalid if an abnormal discrepancy between the values is recorded (see paragraph 3.8.4.3.2. above).

3.8.6.1. Determination of test result

The reference speed V_{ref} used to determine the final result shall be:

- (a) 80 km/h for Class C1 and Class C2 tyres;
- (b) 70 km/h for Class C3 tyres.

3.8.6.2. Regression analysis of rolling sound measurements

The tyre-road rolling sound level LR in dB(A) is determined by a regression analysis according to:

$$L_R = \bar{L} - a \cdot \bar{v}$$

Where:

\bar{L} is the mean value of the rolling sound levels L_i , measured in dB(A):

$$\bar{L} = \frac{1}{n} \sum_{i=1}^n L_i$$

n is the measurement number ($n \geq 16$),

\bar{v} is the mean value of logarithms of speeds v_i :

$$\bar{v} = \frac{1}{n} \sum_{i=1}^n v_i \quad \text{with} \quad v_i = \lg(v_i / v_{ref})$$

"a" is the slope of the regression line in dB(A):

$$a = \frac{\sum_{i=1}^n (v_i - \bar{v})(L_i - \bar{L})}{\sum_{i=1}^n (v_i - \bar{v})^2}$$

3.8.6.3. Temperature correction

For Class C1 and Class C2 tyres, the final result shall be normalized to a test surface reference temperature ϑ_{ref} by applying a temperature correction, according to the following:

$$LR(\vartheta_{ref}) = LR(\vartheta) + K(\vartheta_{ref} - \vartheta)$$

Where:

ϑ = the measured test surface temperature

ϑ_{ref} = 20 °C.

For Class C1 tyres, the coefficient K is:

-0.03 dB(A)/°C when $\vartheta > \vartheta_{ref}$ and

-0.06 dB(A)/°C when $\vartheta < \vartheta_{ref}$.

For Class C2 tyres, the coefficient K is -0.02 dB(A)/°C.

If the measured test surface temperature does not change more than 5 °C within all measurements necessary for the determination of the sound level of one set of tyres, the temperature correction may be made only on the final reported tyre rolling sound level as indicated above, utilizing the arithmetic mean value of the measured temperatures. Otherwise each measured sound level L_i shall be corrected, utilizing the temperature at the time of the sound recording.

3.8.6.4. In order to take account of any measuring instrument inaccuracies, the results according to paragraph 3.8.6.3. shall be reduced by 1 dB(A).

3.8.6.5. The final result, the temperature corrected tyre rolling sound level $L_R(\vartheta_{ref})$ in dB(A), shall be rounded down to the nearest lower whole value.

Figure 5

Microphone positions for the measurement

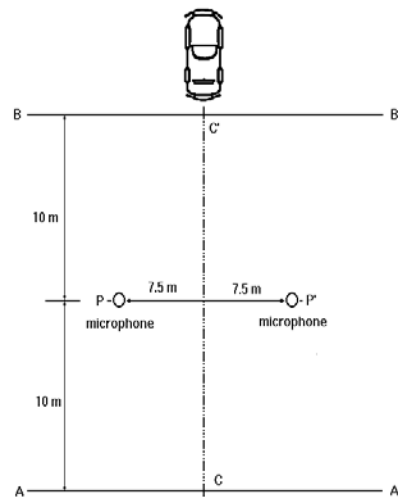

~~3.8.7. Test report: Annex 8 to this regulation shows the test report that may be used to record the results of the tests.~~

3.9. Endurance test for passenger car tyres

3.9.1. Requirements

3.9.1.1. The following requirements shall be met by all passenger car tyres when tested in accordance with the procedures described in paragraphs 3.9.2. and 3.9.3. below.

- 3.9.1.2. There shall be no visible evidence of tread, sidewall, ply, cord, inner liner, belt or bead separation, chunking, open splices, cracking or broken cords.
- 3.9.1.3. The tyre pressure, when measured at any time between 15 minutes and 25 minutes after the end of the test, shall not be less than 95 per cent of the initial pressure specified in paragraph 3.9.2.
- 3.9.2. Preparation of tyre
Mount the tyre on a test rim and inflate it to the pressure specified in the table below.

<i>Endurance test tyre inflation pressures</i>	<i>Tyre application</i>	<i>Test pressure (kPa)</i>
	Standard load, light load	180
	Extra load	220

- 3.9.2.1. Condition the assembly at 35 ± 3 °C for not less than 3 hours.
- 3.9.2.2. Readjust the pressure to the value specified in the table in paragraph 3.9.2. immediately before testing.
- 3.9.3. Test procedure
- 3.9.3.1. Mount the assembly on a test axle and apply a load as given in paragraph 3.9.3.3. below to load it against the outer face of a smooth wheel having a diameter of $1.7 \text{ m} \pm 1$ per cent.
- 3.9.3.2. During the test the ambient temperature, at a distance of not less than 150 mm and not more than 1 m from the tyre, is maintained at 35 ± 3 °C.
- 3.9.3.3. Conduct the test, without interruptions, at not less than 120 km/h (110 km/h for snow tyres for use in severe snow conditions and marked with the three peak mountain snowflake) test speed with loads and test periods not less than those shown in the table below:

Passenger car tyres:

<i>Test period</i>	<i>Duration</i>	<i>Load as a percentage of tyre maximum load capacity</i>
1	4 h	85 %
2	6 h	90 %
3	24 h	100 %

- 3.9.3.4. Throughout the test the inflation pressure shall not be corrected and the test loads shall be kept constant at the value corresponding to each test period.
- 3.9.3.5. Allow the tyre to cool for between 15 and 25 minutes, then measure its inflation pressure. Inspect the tyre externally on the test rim for the conditions specified in paragraph 3.9.1. above.
- 3.10. Low inflation pressure performance test for passenger car tyres
- 3.10.1. Requirements
The following requirements shall be met by tyres when tested in accordance with the procedure given in paragraph 3.10.3. below.

- 3.10.1.1. There shall be no visible evidence of tread, sidewall, ply, cord, inner liner, belt or bead separation, chunking, open splices, cracking or broken cords.
- 3.10.1.2. The tyre pressure, when measured at any time between 15 minutes and 25 minutes after the end of the test, shall not be less than 95 per cent of the initial pressure specified in paragraph 3.10.2. below.

3.10.2. Preparation of tyre

This test is conducted following completion of the tyre endurance test using the same tyre and rim assembly tested in accordance with paragraph 3.9. above, with the tyre deflated to the following pressures show in the table below:

Low inflation pressure performance test

Inflation pressure chart for passenger car tyres

<i>Low inflation pressure performance pressures</i>	<i>Tyre application</i>	<i>Test pressure kPa</i>
Passenger car tyres	Standard load, light load	140
	Extra load	160

- 3.10.2.1. After the tyre is deflated to the appropriate test pressure in paragraph 3.10.2. at the completion of the endurance test, condition the assembly at 35 ± 3 °C for not less than 2 hours.
- 3.10.2.2. Before or after mounting the assembly on a test axle, readjust the tyre pressure to that specified in the table in paragraph 3.10.2.
- 3.10.3. Test procedure
- 3.10.3.1. The test is conducted for ninety minutes at the end of the test specified in paragraph 3.9., continuous and uninterrupted, at a speed of 120 km/h (110 km/h for snow tyres for use in severe snow conditions and marked with the three peak mountain snowflake).
- 3.10.3.2. Press the assembly against the outer face of a test drum with a diameter of $1.7 \text{ m} \pm 1$ per cent.
- 3.10.3.3. Apply to the test axle a load equal to 100 per cent of the tyre's maximum load rating.
- 3.10.3.4. Throughout the test, the inflation pressure is not corrected and the test load is maintained at the initial level.
- 3.10.3.5. During the test, the ambient temperature, at a distance of not less than 150 mm and not more than 1 m from the tyre, is maintained at 35 ± 3 °C.
- 3.10.3.6. Allow the tyre to cool for between 15 and 25 minutes. Measure its inflation pressure. Then deflate the tyre, remove it from the test rim, and inspect it for the conditions specified in paragraph 3.10.1.1. above.
- 3.11. High speed performance test for passenger car tyres
- 3.11.1. Requirements
- When the tyre is tested in accordance with paragraph 3.11.3. or 3.11.5.;

- 3.11.1.1. There shall be no visible evidence of tread, sidewall, ply, cord, inner liner, belt or bead separation, chunking, open splices, cracking or broken cords. For tyres tested at a speed of 300 km/h (speed symbol "Y") or above, superficial blistering in the tyre tread due to localized heat build-up in the test drum is acceptable.
- 3.11.1.2. The tyre pressure, when measured at any time between 15 minutes and 25 minutes after the end of the test, shall not be less than 95 per cent of the initial pressure.
- 3.11.1.3. The outer diameter of the tyre, measured two hours after the load/speed performance test, shall not differ by more than ± 3.5 per cent from the outer diameter as measured before the test.
- 3.11.1.4. For tyres identified by means of letter code "ZR" within the size designation and suitable for speeds over 300 km/h, the above high speed test is carried out on one tyre at the load and speed conditions marked on the tyre. Another load/speed test shall be carried out on a second sample of the same tyre type at the load and speed conditions specified as maximum by the tyre manufacturer. The second test may be carried out on the same tyre sample.
- 3.11.2. Preparation of the tyres with speed symbols "F" to "S" as specified in Annex 1 to this regulation.
- 3.11.2.1. Mount the tyre on a test rim and inflate it to the appropriate pressure specified in the table below:

Inflation pressure and test load:

Speed symbol	Inflation pressure, kPa		Test load
	Standard load tyres, light load tyres	Extra load tyres	
F, G, J, K, L, M, N, P, Q, R, S	220	260	85 % of the load corresponding to the load index

- 3.11.2.2. Condition the assembly at 35 ± 3 °C for not less than three hours.
- 3.11.2.3. Before or after mounting the assembly on a test axle, readjust the tyre pressure to that specified in the table above in paragraph 3.11.2.1.
- 3.11.3. Test procedure for tyres with speed symbols "F", "G", "J", "K", "L", "M", "N", "P", "Q", "R" or "S" as specified in Annex 1
- 3.11.3.1. Press the assembly against the outer face of a test drum with a diameter of $1.7 \text{ m} \pm 1$ per cent.
- 3.11.3.2. Apply to the test axle a load equal to 85 per cent of the tyre's maximum load carrying capacity.
- 3.11.3.3. Break-in the tyre by running it for 2 hours at 80 km/h.
- 3.11.3.4. Allow the tyre to cool to 38 °C and readjust inflation pressure to the applicable pressure in the table in paragraph 3.11.2.1. above immediately before the test.
- 3.11.3.5. Throughout the test, the inflation pressure is not corrected and the test load is maintained at the value applied in paragraph 3.11.2.1.

- 3.11.3.6. During the test, the ambient temperature, measured at a distance of not less than 150 mm and not more than 1 m from the tyre, shall be maintained at 35 ± 3 °C.
- 3.11.3.7. The test is conducted, continuously and uninterrupted, for ninety minutes through three thirty-minute consecutive test stages at the following speeds: 140, 150, and 160 km/h.
- 3.11.3.8. Allow the tyre to cool for between 15 minutes and 25 minutes. Measure its inflation pressure. Then, deflate the tyre, remove it from the test rim, and inspect it for the conditions specified in paragraph 3.11.1.1. above.
- 3.11.4. Preparation of tyres with speed symbols "T" to "Y" as specified in Annex 1 to this Regulation.
- 3.11.4.1. Mount a new tyre on the test rim specified by the manufacturer as the "measuring rim and test rim".
- 3.11.4.2. Inflate it to the appropriate pressure as given (in kPa) in the table below:

Inflation pressure and test load

Speed symbol	Inflation pressure, kPa		Test load
	Standard load tyres, light load tyres	Extra load tyres	
T, U, H	280	320	80 % of the load corresponding to the load index
V	300	340	73 % of the load corresponding to the load index
W	320	360	68 % of the load corresponding to the load index
Y	320	360	68 % of the load corresponding to the load index

- 3.11.4.3. Condition the tyre and wheel assembly at between 20 °C and 30 °C for not less than three hours.
- 3.11.4.4. Re-adjust the tyre pressure to that specified in paragraph 3.11.4.2. above.
- 3.11.5. Test procedure for tyres with speed symbols "T" to "Y" as specified in Annex 1 to this regulation.
- 3.11.5.1. Press the assembly against the outer face of 1.7 m \pm 1 per cent or 2.0 m \pm 1 per cent test drum.
- 3.11.5.2. Depending upon the speed symbol applicable to the tyre, apply a load to the test axle equal to that shown in the table in paragraph 3.11.4.2. above.
- 3.11.5.3. Throughout the test the tyre pressure shall not be corrected and the test load shall be kept constant.
- 3.11.5.4. During the test the temperature in the test-room shall be maintained at between 20 °C and 30 °C or at a higher temperature if the manufacturer desires to increase test severity.

- 3.11.5.5. Carry the test through, without interruptions as follows, in relation to the tyre's speed symbol.
- 3.11.5.6. The initial test speed (ITS) is equal to the tyre's speed symbol:
 - (a) Less 40 km/h on a 1.70 m \pm 1 per cent drum, or
 - (b) Less 30 km/h on a 2.0 m \pm 1 per cent drum.
- 3.11.6. For tyres of speed symbols "T" to "W" as specified in Annex 1;
- 3.11.6.1. Accelerate the equipment at a constant rate such that the initial test speed (ITS) is reached at the end of 10 minutes from start-up.
 - (a) Then, at the ITS for 10 minutes;
 - (b) Then, at the ITS plus 10 km/h for 10 minutes;
 - (c) Then, at the ITS plus 20 km/h for 10 minutes;
 - (d) Then, at the ITS plus 30 km/h for 20 minutes.
- 3.11.6.2. For tyres of speed symbol "Y": Accelerate the equipment at a constant rate such that the Initial Test Speed (ITS) is reached at the end of 10 minutes from start-up.
 - (a) Then, at the ITS for 20 minutes;
 - (b) Then, at the ITS plus 10 km/h for 10 minutes.
 - (c) Then, at the ITS plus 20 km/h for 10 minutes;
 - (d) Then, at the ITS plus 30 km/h for 10 minutes.
- 3.11.7. For tyres with "ZR" in the size designation intended for use at speeds greater than 300 km/h;
- 3.11.7.1. Test the tyre at the load and inflation for a speed symbol "Y" tyre according to the procedures specified above in paragraphs 3.11.4.2. and 3.11.6.2. above.
- 3.11.7.2. Test a further sample of the same type according to:

Inflate the tyre to 320 kPa for standard load or light load tyres and 360 kPa for extra load tyres. Apply a load to the test axle that is equal to 80 per cent of the load capacity specified by the tyre manufacturer. Accelerate the equipment at a constant rate such that the rated speed of the tyre is reached at the end of 10 minutes from the start-up. Then test at the rated speed for 5 minutes.
- 3.12. Test for adhesion performance on wet surfaces
- 3.12.1. Requirements

The following requirements do not apply to professional off-road tyres, tyres fitted with additional devices to improve traction properties (e.g. studded tyres), tyres with a speed rating less than 80 km/h (speed symbol F) and those having a nominal rim diameter code ≤ 10 (or ≤ 254 mm) or ≥ 25 (or ≥ 635 mm).

~~Passenger-car tyres (For Class C1 tyres), tested in accordance with either procedure given in paragraph 3.12.2., the tyre shall meet the following requirements:~~

Category of use ⁹		Wet grip index (G)
Normal tyre		≥ 1.1
Snow tyre	"Snow tyre for use in severe snow conditions" and with a speed symbol ("R" and above, including "H") indicating a maximum permissible speed greater than 160 km/h	≥ 1.0
	"Snow tyre for use in severe snow conditions" and with a speed symbol ("Q" or below excluding "H") indicating a maximum permissible speed not greater than 160 km/h	≥ 0.9
Special use tyre		Not defined

Comment [JN49]: Agreement during GRRF 80th to deleted the below 3 footnotes from part II and move the proper comment in the introduction.

For Class C2 tyres, tested in accordance with either procedure given in paragraph 3.12.3.,the tyre shall meet the following requirements:

Category of use ¹⁰		Wet grip index (G)	
		Other	Traction tyres
Normal tyre		≥ 0.95	≥ 0.85
Snow tyre		≥ 0.95	≥ 0.85
	Snow tyre for use in severe snow conditions	≥ 0.85	≥ 0.85
Special use tyre		≥ 0.85	≥ 0.85

Comment [JN50]: Revision 3 - Amendment 2
Supplement 6 to the 02 series of amendments – Date of entry into force: 9 October 2014
WP.29/2013/66

For Class C3 tyres, tested in accordance with either procedure given in paragraph 3.12.3., the tyre shall meet the following requirements:

Category of use ¹¹		Wet grip index (G)	
		Other	Traction tyres
Normal tyre		≥ 0.80	≥ 0.65
Snow tyre		≥ 0.65	≥ 0.65
	Snow tyre for use in severe snow conditions	≥ 0.65	≥ 0.65
Special use tyre		≥ 0.65	≥ 0.65

Comment [JN51]: Revision 3 - Amendment 2
Supplement 6 to the 02 series of amendments – Date of entry into force: 9 October 2014
WP.29/2013/66

⁹ Following additional technical evaluation, a future additional category of use is anticipated might be necessary for certain tyre types typical in the North American market, as referenced in 1.A. Introduction and Procedural Background.

¹⁰ Following additional technical evaluation, a future additional category of use is anticipated might be necessary for certain tyre types typical in the North American market, as referenced in 1.A. Introduction and Procedural Background.

¹¹ Following additional technical evaluation, a future additional category of use might be necessary for certain tyre types typical in the North American market, as referenced in 1.A. Introduction and Procedural Background.

3.12.2. CI category tyres**3.12.2.1. Reference standards**

The following documents listed apply.

- 3.12.2.1.1. ASTM E 303-93 (Reapproved 2008), Standard Test Method for Measuring Surface Frictional Properties Using the British Pendulum Tester.
- 3.12.2.1.2. ASTM E 501-08, Standard Specification for Standard Rib Tire for Pavement Skid-Resistance Tests.
- 3.12.2.1.3. ASTM E 965-96 (Reapproved 2006), Standard Test Method for Measuring Pavement Macrotexture Depth Using a Volumetric Technique.

3.12.2.2. General test conditions**3.12.2.2.1. Track characteristics**

The test track shall have the following characteristics:

- 3.12.2.2.1.1. The surface shall have a dense asphalt surface with a uniform gradient of not more than 2 per cent and shall not deviate more than 6 mm when tested with a 3 m straight edge.
- 3.12.2.2.1.2. The surface shall have a pavement of uniform age, composition, and wear. The test surface shall be free of loose material and foreign deposits.
- 3.12.2.2.1.3. The maximum chipping size shall be 10 mm (tolerances permitted from 8 mm to 13 mm).
- 3.12.2.2.1.4. The texture depth as measured by a sand patch shall be 0.7 ± 0.3 mm. It shall be measured in accordance with ASTM E 965-96 (Reapproved 2006).
- 3.12.2.2.1.5. The wetted frictional properties of the surface shall be measured with either method (a) or (b) in section 3.12.2.2.2.

3.12.2.2.2. Methods to measure the wetted frictional properties of the surface**3.12.2.2.2.1. British Pendulum Number (BPN) method (a)**

The British Pendulum Number method shall be as defined in ASTM E 303-93 (Reapproved in 2008).

Pad rubber component formulation and physical properties shall be as specified in ASTM E 501-08.

The averaged British Pendulum Number (BPN) shall be between 42 and 60 BPN after temperature correction as follows.

BPN shall be corrected by the wetted road surface temperature. Unless temperature correction recommendations are indicated by the British pendulum manufacturer, the following formula is used:

$BPN = BPN(\text{measured value}) + \text{temperature correction}$

$\text{temperature correction} = -0.0018 t^2 + 0.34 t - 6.1$

where t is the wetted road surface temperature in degrees Celsius.

Comment [JN52]: Revision 2 – Amendment 1
 Supplement 1 to the 02 series of amendments - Date of entry into force: 18 November 2012
 WP.29/2012/2

Effects of slider pad wear: the pad shall be removed for maximum wear when the wear on the striking edge of the slider reaches 3.2 mm in the plane of the slider or 1.6 mm vertical to it in accordance with section 5.2.2. and Figure 3 of ASTM E 303-93 (Reapproved 2008).

For the purpose of checking track surface BPN consistency for the measurement of wet grip on an instrumented passenger car: the BPN values of the test track should not vary over the entire stopping distance so as to decrease the dispersion of test results. The wetted frictional properties of the surface shall be measured five times at each point of the BPN measurement every 10 meters and the coefficient of variation of the averaged BPN shall not exceed 10 per cent.

3.12.2.2.2.2. ASTM E 1136 Standard Reference Test Tyre method (b)

This method uses the reference tyre that has the characteristics indicated in the ASTM E 1136-93 (Reapproved 2003) and referred to as SRTT14.

The average peak braking force coefficient ($\mu_{\text{peak,ave}}$) of the SRTT14 shall be 0.7 ± 0.1 at 65 km/h.

The average peak braking force coefficient ($\mu_{\text{peak,ave}}$) of the SRTT14 shall be corrected for the wetted road surface temperature as follows:

Peak braking force coefficient ($\mu_{\text{peak,ave}}$) = peak braking force coefficient (measured) + temperature correction

Temperature correction = $0.0035 \times (t - 20)$

Where t is the wetted road surface temperature in degrees Celsius.

3.12.2.2.3. Atmospheric conditions

The wind conditions shall not interfere with wetting of the surface (wind-shields are allowed).

Both the wetted surface temperature and the ambient temperature shall be between 2 °C and 20 °C for snow tyres and 5 °C and 35 °C for normal tyres.

The wetted surface temperature shall not vary during the test by more than 10 °C.

The ambient temperature must remain close to the wetted surface temperature; the difference between the ambient and the wetted surface temperatures must be less than 10 °C.

3.12.2.3. Testing methods for measuring wet grip

For the calculation of the wet grip index (G) of a candidate tyre, the wet grip braking performance of the candidate tyre is compared to the wet grip braking performance of the reference tyre on a vehicle travelling straight ahead on a wet, paved surface. It is measured with one of the following methods:

- (a) Vehicle method consisting of testing a set of tyres mounted on an instrumented passenger car;
- (b) Testing method using a trailer towed by a vehicle or a tyre test vehicle, equipped with the test tyre(s).

3.12.2.3.1. Testing method (a) using an instrumented passenger car

3.12.2.3.1.1. Principle

The testing method covers a procedure for measuring the deceleration performance of C1 tyres during braking, using an instrumented passenger car equipped with an Antilock Braking System (ABS), where "instrumented passenger car" means a passenger car that is fitted with the measuring equipment listed in section 4.1.2.2. for the purpose of this testing method. Starting with a defined initial speed, the brakes are applied hard enough on four wheels at the same time to activate the ABS. The average deceleration is calculated between two pre-defined speeds.

3.12.2.3.1.2. Equipment

3.12.2.3.1.2.1. Vehicle

Permitted modifications on the passenger car are as follows:

- (a) Those allowing the number of tyre sizes that can be mounted on the vehicle to be increased;
- (b) Those permitting automatic activation of the braking device to be installed;
- (c) Any other modification of the braking system is prohibited.

3.12.2.3.1.2.2. Measuring equipment

The vehicle shall be fitted with a sensor suitable for measuring speed on a wet surface and distance covered between two speeds.

To measure vehicle speed, a fifth wheel or non-contact speed-measuring system shall be used.

3.12.2.3.1.3. Conditioning of the test track and wetting condition

The test track surface shall be watered at least half an hour prior to testing in order to equalize the surface temperature and water temperature. External watering should be supplied continuously throughout testing. For the whole testing area, the water depth shall be 1.0 ± 0.5 mm, measured from the peak of the pavement.

The test track should then be conditioned by conducting at least ten test runs with tyres not involved in the test programme at 90 km/h.

3.12.2.3.1.4. Tyres and rims

3.12.2.3.1.4.1. Tyre preparation and break-in

The test tyres shall be trimmed to remove all protuberances on the tread surface caused by mould air vents or flashes at mould junctions.

Fit the test tyres on rims specified by a recognized tyre and rim standards organization as listed in Annex 7.

3.12.2.3.1.4.2. Tyre load

The static load on each axle tyre shall lie between 60 per cent and 90 per cent of the tested tyre load capacity. Tyre loads on the same axle should not differ by more than 10 per cent.

3.12.2.3.1.4.3. Tyre inflation pressure

Comment [JN53]: Before testing, the track shall be conditioned e.g. by carrying out at least ten braking tests on the part of the track to be used for the performance test programme but using a tyre not involved in that programme. Decision special GRRF June 2014.

Comment [AR54]: Revision 3 - Amendment 2
Supplement 6 to the 02 series of amendments – Date of entry into force: 9 October 2014
WP.29/2013/66

On the front and rear axles, the inflation pressures shall be 220 kPa (for standard- and extra load tyres). The tyre pressure should be checked just prior to testing at ambient temperature and adjusted if required.

3.12.2.3.1.5. Procedure

3.12.2.3.1.5.1. Test run

The following test procedure applies for each test run.

3.12.2.3.1.5.1.1. The passenger car is driven in a straight line up to 85 ± 2 km/h.

3.12.2.3.1.5.1.2. Once the passenger car has reached 85 ± 2 km/h, the brakes are always activated at the same place on the test track referred to as "braking starting point", with a longitudinal tolerance of 5 m and a transverse tolerance of 0.5 m.

3.12.2.3.1.5.1.3. The brakes are activated either automatically or manually.

3.12.2.3.1.5.1.3.1. The automatic activation of the brakes is performed by means of a detection system made of two parts, one indexed to the test track and one on board the passenger car.

3.12.2.3.1.5.1.3.2. The manual activation of the brakes depends on the type of transmission as follows. In both cases, a minimum of 600 N pedal efforts is required.

For manual transmission, the driver should release the clutch and depress the brake pedal sharply, holding it down as long as necessary to perform the measurement.

For automatic transmission, the driver should select neutral gear and then depress the brake pedal sharply, holding it down as long as necessary to perform the measurement.

3.12.2.3.1.5.1.4. The average deceleration is calculated between 80 km/h and 20 km/h.

If any of the specifications listed above (including speed tolerance, longitudinal and transverse tolerance for the braking starting point, and braking time) are not met when a test run is made, the measurement is discarded and a new test run is made.

3.12.2.3.1.5.2. Test cycle

A number of test runs are made in order to measure the wet grip index of a set of candidate tyres (T) according to the following procedure, whereby each test run shall be made in the same direction and up to three different sets of candidate tyres may be measured within the same test cycle:

3.12.2.3.1.5.2.1. First, the set of reference tyres are mounted on the instrumented passenger car.

3.12.2.3.1.5.2.2. After at least three valid measurements have been made in accordance with section 4.1.5.1., the set of reference tyres is replaced by a set of candidate tyres.

3.12.2.3.1.5.2.3. After six valid measurements of the candidate tyres are performed, two more sets of candidate tyres may be measured.

3.12.2.3.1.5.2.4. The test cycle is closed by three more valid measurements of the same set of reference tyres as at the beginning of the test cycle.

Examples:

(a) The run order for a test cycle of three sets of candidate tyres (T1 to T3) plus a set of reference tyres (R) would be the following:

R-T1-T2-T3-R

(b) The run order for a test cycle of five sets of candidate tyres (T1 to T5) plus a set of reference tyres (R) would be the following:

R-T1-T2-T3-R-T4-T5-R

3.12.2.3.1.6. Processing of measurement results

3.12.2.3.1.6.1. Calculation of the average deceleration (AD)

The average deceleration (AD) is calculated for each valid test run in m/s^2 as follows:

$$AD = \left| \frac{S_f^2 - S_i^2}{2d} \right|$$

where:

S_f is the final speed in m/s; $S_f = 20 \text{ km/h} = 5.556 \text{ m/s}$

S_i is the initial speed in m/s; $S_i = 80 \text{ km/h} = 22.222 \text{ m/s}$

d is the distance covered between S_i and S_f in metre.

3.12.2.3.1.6.2. Validation of results

The AD coefficient of variation is calculated as follows:

(Standard Deviation / Average) x 100.

For the reference tyres (R): If the AD coefficient of variation of any two consecutive groups of three tests runs of the reference tyre set is higher than 3 per cent, all data should be discarded and the test repeated for all test tyres (the candidate tyres and the reference tyres).

For the candidate tyres (T): The AD coefficients of variation are calculated for each candidate tyre set. If one coefficient of variation is higher than 3 per cent, the data should be discarded and the test repeated for that candidate tyre set.

3.12.2.3.1.6.3. Calculation of adjusted average deceleration (Ra)

The average deceleration (AD) of the reference tyre set used for the calculation of its braking force coefficient is adjusted according to the positioning of each candidate tyre set in a given test cycle.

This adjusted AD of the reference tyre (Ra) is calculated in m/s^2 in accordance with Table 1 where R_1 is the average of the AD values in the first test of the reference tyre set (R) and R_2 is the average of the AD values in the second test of the same reference tyre set (R).

Table 1

<i>Number of sets of candidate tyres within one test cycle</i>	<i>Set of candidate tyres</i>	<i>R_a</i>
1 (R ₁ -T1-R ₂)	T1	R _a = 1/2 (R ₁ + R ₂)
2 (R ₁ -T1-T2-R ₂)	T1	R _a = 2/3 R ₁ + 1/3 R ₂
	T2	R _a = 1/3 R ₁ + 2/3 R ₂
3 (R ₁ -T1-T2-T3-R ₂)	T1	R _a = 3/4 R ₁ + 1/4 R ₂
	T2	R _a = 1/2 (R ₁ + R ₂)
	T3	R _a = 1/4 R ₁ + 3/4 R ₂

3.12.2.3.1.6.4. Calculation of the braking force coefficient (BFC)

The braking force coefficient (BFC) is calculated for a braking on the two axles according to Table 2 where T_a (a = 1, 2 or 3) is the average of the AD values for each candidate tyre (T) set that is part of a test cycle.

Table 2

Test Tyre	Braking force coefficient
Reference tyre	BFC(R) = R _a /g
Candidate tyre	BFC(T) = T _a /g
<i>g is the acceleration due to gravity, g = 9.81 m/s²</i>	

3.12.2.3.1.6.5. Calculation of the wet grip index of the candidate tyre

The wet grip index of the candidate tyre (G(T)) is calculated as follows:

$$G(T) = \left[\frac{BF(T)}{BF(R)} \times 125 + a \times (t - t_0) + b \times \left(\frac{BF(R)}{BF(R_0)} - 1, 0 \right) \right] \times 10^{-2}$$

where:

t is the measured wet surface temperature in degree Celsius when the candidate tyre (T) is tested

*t*₀ is the wet surface reference temperature condition, *t*₀ = 20 °C for normal tyres and *t*₀ = 10 °C for snow tyres

BFC(R₀) is the braking force coefficient for the reference tyre in the reference conditions, BFC(R₀) = 0.68

a = -0.4232 and *b* = -8.297 for normal tyres, *a* = 0.7721 and *b* = 31.18 for snow tyres [*a* is expressed as (1/°C)]

3.12.2.3.1.7. Wet grip performance comparison between a candidate tyre and a reference tyre using a control tyre**3.12.2.3.1.7.1. General**

Where the candidate tyre size is significantly different from that of the reference tyre, a direct comparison on the same instrumented passenger

car may not be possible. This testing method uses an intermediate tyre, hereinafter called the control tyre as defined in paragraph 2.5.

3.12.2.3.1.7.2. Principle of the approach

The principle is the use of a control tyre set and two different instrumented passenger cars for the test cycle of a candidate tyre set in comparison with a reference tyre set.

One instrumented passenger car is fitted with the reference tyre set followed by the control tyre set, the other with the control tyre set followed by the candidate tyre set.

The specifications listed in sections 4.1.2. to 4.1.4. apply.

The first test cycle is a comparison between the control tyre set and the reference tyre set.

The second test cycle is a comparison between the candidate tyre set and the control tyre set. It is done on the same test track and during the same day as the first test cycle. The wetted surface temperature shall be within ± 5 °C of the temperature of the first test cycle. The same control tyre set shall be used for the first and the second test cycles.

The wet grip index of the candidate tyre (G(T)) is calculated as follows:

$$G(T) = G_1 \times G_2$$

where:

G_1 is the relative wet grip index of the control tyre (C) compared to the reference tyre (R) calculated as follows:

$$G_1 = \left[\frac{BF(C)}{BF(R)} \times 125 + a \times (t - t_0) + b \times \left(\frac{BF(R)}{BF(R_0)} - 1.0 \right) \right] \times 10^{-2}$$

G_2 is the relative wet grip index of the candidate tyre (T) compared to the control tyre (C) calculated as follows:

$$G_2 = \frac{BF(T)}{BF(C)}$$

3.12.2.3.1.7.3. Storage and preservation

It is necessary that all the tyres of a control tyre set have been stored in the same conditions. As soon as the control tyre set has been tested in comparison with the reference tyre, the specific storage conditions defined in ASTM E 1136-93 (Reapproved 2003) shall be applied.

3.12.2.3.1.7.4. Replacement of reference tyres and control tyres

When irregular wear or damage results from tests, or when wear influences the test results, the use of the tyre shall be discontinued.

3.12.2.3.2. Testing method (b) using a trailer towed by a vehicle or a tyre test vehicle

3.12.2.3.2.1. Principle

The measurements are conducted on test tyres mounted on a trailer towed by a vehicle (hereafter referred to as tow vehicle) or on a tyre test vehicle. The brake in the test position is applied firmly until sufficient braking torque is generated to produce the maximum braking force that will occur prior to wheel lockup at a test speed of 65 km/h.

3.12.2.3.2.2. Equipment

3.12.2.3.2.2.1. Tow vehicle and trailer or tyre test vehicle

The tow vehicle or the tyre test vehicle shall have the capability of maintaining the specified speed of 65 ± 2 km/h even under the maximum braking forces.

The trailer or the tyre test vehicle shall be equipped with one place where the tyre can be fitted for measurement purposes hereafter called 'test position' and the following accessories:

- (a) Equipment to activate brakes in the test position;
- (b) A water tank to store sufficient water to supply the road surface wetting system, unless external watering is used;
- (c) Recording equipment to record signals from transducers installed at the test position and to monitor water application rate if the self-watering option is used.

The maximum variation of toe-settings and camber angle for the test position shall be within $\pm 0.5^\circ$ with maximum vertical load. Suspension arms and bushings shall have sufficient rigidity necessary to minimize free play and ensure compliance under application of maximum braking forces. The suspension system shall provide adequate load-carrying capacity and be of such a design as to isolate suspension resonance.

The test position shall be equipped with a typical or special automotive brake system which can apply sufficient braking torque to produce the maximum value of braking test wheel longitudinal force at the conditions specified.

The brake application system shall be able to control the time interval between initial brake application and peak longitudinal force as specified in paragraph 3.12.2.3.2.7.1.

The trailer or the tyre test vehicle shall be designed to accommodate the range of candidate tyre sizes to be tested.

The trailer or the tyre test vehicle shall have provisions for adjustment of vertical load as specified in paragraph 3.12.2.3.2.5.2.

3.12.2.3.2.2.2. Measuring equipment

The test wheel position on the trailer or the tyre test vehicle shall be equipped with a rotational wheel velocity measuring system and with transducers to measure the braking force and vertical load at the test wheel.

General requirements for measurement system: The instrumentation system shall conform to the following overall requirements at ambient temperatures between 0 °C and 45 °C:

- (a) Overall system accuracy, force: ± 1.5 per cent of the full scale of the vertical load or braking force;
- (b) Overall system accuracy, speed: ± 1.5 per cent of speed or ± 1.0 km/h, whichever is greater.

Vehicle speed: To measure vehicle speed, a fifth wheel or non-contact precision speed-measuring system should be used.

Braking forces: The braking force-measuring transducers shall measure longitudinal force generated at the tyre–road interface as a result of brake application within a range from 0 per cent to at least 125 per cent of the applied vertical load. The transducer design and location shall minimize inertial effects and vibration-induced mechanical resonance.

Vertical load: The vertical load-measuring transducer shall measure the vertical load at the test position during brake application. The transducer shall have the same specifications as described previously.

Signal conditioning and recording system: All signal conditioning and recording equipment shall provide linear output with necessary gain and data reading resolution to meet the specified previous requirements. In addition, the following requirements apply:

- (a) The minimum frequency response shall be flat from 0 Hz to 50 Hz (100 Hz) within ± 1 per cent full scale;
- (b) The signal-to-noise ratio shall be at least 20/1;
- (c) The gain shall be sufficient to permit full-scale display for full-scale input signal level;
- (d) The input impedance shall be at least ten times larger than the output impedance of the signal source;
- (e) The equipment shall be insensitive to vibrations, acceleration, and changes in ambient temperature.

3.12.2.3.2.3. Conditioning of the test track

The test track should be conditioned by conducting at least ten test runs with tyres not involved in the test program at 65 ± 2 km/h.

3.12.2.3.2.4. Wetting conditions

The tow vehicle and trailer or the tyre test vehicle may be optionally equipped with a pavement-wetting system, less the storage tank, which, in the case of the trailer, is mounted on the tow vehicle. The water being applied to the pavement ahead of the test tyres shall be supplied by a nozzle suitably designed to ensure that the water layer encountered by the test tyre has a uniform cross section at the test speed with a minimum splash and overspray.

The nozzle configuration and position shall ensure that the water jets are directed towards the test tyre and pointed towards the pavement at an angle of 20° to 30°.

Comment [JN55]: Before testing, the track shall be conditioned e.g. by carrying out at least ten braking tests on the part of the track to be used for the performance test programme but using a tyre not involved in that programme. Decision special GRRF of June 2014

The water shall strike the pavement 250 mm to 450 mm ahead of the centre of tyre contact. The nozzle shall be located 25 mm above the pavement or at the minimum height required to clear obstacles which the tester is expected to encounter, but in no case more than 100 mm above the pavement.

The water layer shall be at least 25 mm wider than the test tyre tread and applied so the tyre is centrally located between the edges. Water delivery rate shall ensure a water depth of 1.0 ± 0.5 mm and shall be consistent throughout the test to within ± 10 per cent. The volume of water per unit of wetted width shall be directly proportional to the test speed. The quantity of water applied at 65 km/h shall be 18 l/s per meter of width of wetted surface in case of a water depth of 1.0 mm.

3.12.2.3.2.5. Tyres and rims

3.12.2.3.2.5.1. Tyre preparation and break-in

The test tyres shall be trimmed to remove all protuberances on the tread surface caused by mould air vents or flashes at mould junctions.

The test tyre shall be mounted on the test rim declared by the tyre manufacturer.

A proper bead seat should be achieved by the use of a suitable lubricant. Excessive use of lubricant should be avoided to prevent slipping of the tyre on the wheel rim.

The test tyres/rim assemblies shall be stored in a location for a minimum of two hours such that they all have the same ambient temperature prior to testing. They should be shielded from the sun to avoid excessive heating by solar radiation.

For tyre break-in, at least two braking runs shall be performed under the load, pressure and speed as specified in paragraphs 3.12.2.3.4.2.5.2, 3.12.2.3.4.2.5.3 and 3.12.2.3.4.2.7.1 respectively.

3.12.2.3.2.5.2. Tyre load

The test load on the test tyre is 75 ± 5 per cent of the tyre load capacity.

3.12.2.3.2.5.3. Tyre inflation pressure

The test tyre cold inflation pressure shall be 180 kPa for standard-load tyres. For extra load tyres, the cold inflation pressure shall be 220 kPa.

The tyre pressure should be checked just prior to testing at ambient temperature and adjusted if required.

3.12.2.3.2.6. Preparation of the tow vehicle and trailer or the tyre test vehicle

3.12.2.3.2.6.1. Trailer

For one axle trailers, the hitch height and transverse position shall be adjusted once the test tyre has been loaded to the specified test load in order to avoid any disturbance of the measuring results. The longitudinal distance from the centre line of the articulation point of the coupling to the transverse centre line of the axle of the trailer shall be at least ten times the "hitch height" or the "coupling (hitch) height".

3.12.2.3.2.6.2. Instrumentation and equipment

Comment [JN56]: Requested by NHTSA in extra meeting of GRRF in June 2014.

Install the fifth wheel, when used, in accordance with the manufacturer's specifications and locate it as near as possible to the mid-track position of the tow trailer or the tyre test vehicle.

3.12.2.3.2.7. Procedure

3.12.2.3.2.7.1. Test run

The following procedure applies for each test run:

3.12.2.3.2.7.1.1. The tow vehicle or the tyre test vehicle is driven onto the test track in a straight line at the specified test speed 65 ± 2 km/h.

3.12.2.3.2.7.1.2. The recording system is launched.

3.12.2.3.2.7.1.3. Water is delivered to the pavement ahead of the test tyre approximately 0.5 s prior to brake application (for internal watering system).

3.12.2.3.2.7.1.4. The trailer brakes are activated within 2 metres of a measurement point of the wetted frictional properties of the surface and sand depth in accordance with paragraphs 3.12.2.2.1.4. and 3.12.2.2.1.5 . The rate of braking application shall be such that the time interval between initial application of force and peak longitudinal force is in the range 0.2 s to 0.5 s.

3.12.2.3.2.7.1.5. The recording system is stopped.

3.12.2.3.2.7.2. Test cycle

A number of test runs are made in order to measure the wet grip index of the candidate tyre (T) according to the following procedure, whereby each test run shall be made from the same spot on the test track and in the same direction. Up to three candidate tyres may be measured within the same test cycle, provided that the tests are completed within one day.

3.12.2.3.2.7.2.1. First, the reference tyre is tested.

3.12.2.3.2.7.2.2. After at least six valid measurements are performed in accordance with paragraph 3.12.2.3.2.7.1. the reference tyre is replaced by the candidate tyre.

3.12.2.3.2.7.2.3. After six valid measurements of the candidate tyre are performed, two more candidate tyres may be measured.

3.12.2.3.2.7.2.4. The test cycle is closed by six more valid measurements of the same reference tyre as at the beginning of the test cycle.

Examples:

(a) The run order for a test cycle of three candidate tyres (T1 to T3) plus the reference tyre (R) would be the following:

R-T1-T2-T3-R

(b) The run order for a test cycle of five candidate tyres (T1 to T5) plus the reference tyre R would be the following:

R-T1-T2-T3-R-T4-T5-R

3.12.2.3.2.8. Processing of measurement results

3.12.2.3.2.8.1. Calculation of the peak braking force coefficient

The tyre peak braking force coefficient (μ_{peak}) is the highest value of $\mu(t)$ before lockup occurs calculated as follows for each test run. Analogue signals should be filtered to remove noise. Digitally recorded signals must be filtered using a moving average technique.

$$\mu(t) = \left| \frac{fh(t)}{fv(t)} \right|$$

where:

$\mu(t)$ is the dynamic tyre braking force coefficient in real time;

$fh(t)$ is the dynamic braking force in real time, in N;

$fv(t)$ is the dynamic vertical load in real time, in N.

3.12.2.3.2.8.2. Validation of results

The μ_{peak} coefficient of variation is calculated as follows:

(Standard Deviation / Average) x 100

For the reference tyre (R): If the coefficient of variation of the peak braking force coefficient (μ_{peak}) of the reference tyre is higher than 5 per cent, all data should be discarded and the test repeated for all test tyres (the candidate tyre(s) and the reference tyre).

For the candidate tyre(s) (T): The coefficient of variation of the peak braking force coefficient (μ_{peak}) is calculated for each candidate tyre. If one coefficient of variation is higher than 5 per cent, the data should be discarded and the test repeated for this candidate tyre.

3.12.2.3.2.8.3. Calculation of the adjusted average peak braking force coefficient

The average peak braking force coefficient of the reference tyre used for the calculation of its braking force coefficient is adjusted according to the positioning of each candidate tyre in a given test cycle.

This adjusted average peak braking force coefficient of the reference tyre (R_a) is calculated in accordance with table 3 where R_1 is the average peak tyre braking coefficient in the first test of the reference tyre (R) and R_2 is the average peak tyre braking coefficient in the second test of the same reference tyre (R).

Table 3

<i>Number of candidate tyre(s) within one test cycle</i>	<i>Candidate tyre</i>	<i>R_a</i>
1 (R ₁ -T1-R ₂)	T1	R _a = 1/2 (R ₁ + R ₂)
2 (R ₁ -T1-T2-R ₂)	T1	R _a = 2/3 R ₁ + 1/3 R ₂
	T2	R _a = 1/3 R ₁ + 2/3 R ₂
3 (R ₁ -T1-T2-T3-R ₂)	T1	R _a = 3/4 R ₁ + 1/4 R ₂
	T2	R _a = 1/2 (R ₁ + R ₂)

	T3	Ra = 1/4 R₁ + 3/4 R₂
--	-----------	---

3.12.2.3.2.8.4 Calculation of the average peak braking coefficient ($\mu_{\text{peak,ave}}$)

The average value of the peak braking coefficients ($\mu_{\text{peak,ave}}$) is calculated according to table 4 whereby Ta (a= 1, 2 or 3) is the average of the peak braking force coefficients measured for one candidate tyre within one test cycle.

Table 4

Test tyre	$\mu_{\text{peak,ave}}$
Reference tyre	$\mu_{\text{peak,ave}}(\text{R})=\text{Ra as per Table 3}$
Candidate tyre	$\mu_{\text{peak,ave}}(\text{T}) = \text{Ta}$

3.12.2.3.2.8.5. Calculation of the wet grip index of the candidate tyre

The wet grip index of the candidate tyre (G(T)) is calculated as follows:

$$G(T) = \left[\frac{\mu_{\text{peak,ave}}(T)}{\mu_{\text{peak,ave}}(R)} \times 125 + a \times (t - t_0) + b \times \left(\frac{\mu_{\text{peak,ave}}(R)}{\mu_{\text{peak,ave}}(R_0)} - 1 \right) \right] \times 10^{-2}$$

where:

t is the measured wet surface temperature in degree Celsius when the candidate tyre (T) is tested

t₀ is the wet surface reference temperature condition

t₀ = 20 °C for normal tyres t₀=10°C for snow tyres

$\mu_{\text{peak,ave}}(\text{R}_0) = 0.85$ is the peak braking force coefficient for the reference tyre in the reference conditions

a = -0.4232 and b = -8.297 for normal tyres, a = 0.7721 and b = 31.18 for snow tyres" [a is expressed as (1/°C)]

3.12.3. C2 and C3 category tyres

3.12.3.1. General test conditions

3.12.3.1.1. Track characteristics

The surface shall be a dense asphalt surface with a uniform gradient of not more than two per cent and shall not deviate more than 6 mm when tested with a 3 m straightedge.

The test surface shall have a pavement of uniform age, composition, and wear. The test surface shall be free of loose material or foreign deposits.

The maximum chipping size shall be from 8 mm to 13 mm.

The sand depth measured as specified in EN13036-1:2001 and ASTM E 965-96 (reapproved 2006) shall be 0.7 ± 0.3 mm.

Comment [JN57]: Revision 3 - Amendment 2
 Supplement 6 to the 02 series of amendments – Date of entry into force: 9 October 2014
 WP.29/2013/66

The surface friction value for the wetted track shall be established by one or other of the following methods ~~according to the discretion of the Contracting Party.~~

3.12.3.1.1.1. Standard reference test tyre (SRTT) method

The average peak braking coefficient (μ peak average) of the ASTM E1136 -93 (reapproved 2003) reference tyre (Test method using a trailer or a tyre test vehicle as specified in clause 2.1) shall be 0.7 +/- 0.1 (at 65 km/h and 180 kPa). The measured values shall be corrected for the effects of temperature as follows:

$$pbfc = pbfc (\text{measured}) + 0.0035 (t - 20)$$

Where "t" is the wetted track surface temperature in degrees Celsius.

The test shall be conducted using the lanes and length of the track to be used for the wet grip test.

For the trailer method, testing is run in such a way that braking occurs within 10 metres distance of where the surface was characterized.

3.12.3.1.1.2. British Pendulum Number (BPN) method

The averaged British Pendulum Number (BPN) British Pendulum Tester method as specified in ASTM E 303-93 (reapproved 2008) using the Pad as specified in ASTM E 501-08 shall be (50 ± 10) BPN after temperature correction.

BPN shall be corrected by the wetted road surface temperature. Unless temperature correction recommendations are indicated by the British pendulum manufacturer the following formula can be used:

$$BPN = BPN (\text{measured value}) - (0.0018 \cdot t^2) + 0.34 \cdot t - 6.1$$

Where: "t" is the wetted road surface temperature in degrees Celsius.

Effects of slider pad wear: the pad should be removed for maximum wear when the wear on the striking edge of the slider reaches 3.2 mm in the plane of the slider or 1.6 mm vertical to it.

Check the test track testing surface BPN consistency for the measurement of wet grip on a standard vehicle.

In the lanes of the track to be used during the wet grip tests, the BPN shall be measured at intervals of 10 m along the length of the lanes. The BPN shall be measured 5 times at each point and the coefficient of variation of the BPN averages shall not exceed 10 per cent.

3.12.3.1.2. The surface may be wetted from the track-side or by a wetting system incorporated into the test vehicle or the trailer.

If a track-side system is used, the test surface shall be wetted for at least half an hour prior to testing in order to equalize the surface temperature and water temperature. It is recommended that track-side wetting be continuously applied throughout testing.

The water depth shall be between 0.5 and 2.0 mm.

3.12.3.1.3. The wind conditions shall not interfere with wetting of the surface (wind-shields are permitted).

The ambient and the wetted surface temperature shall be between 5 °C and 35 °C and shall not vary during the test by more than 10 °C.

Comment [JN58]: Agreement given in GRRF 80th session that provisions for transposition into the National regulations will be removed from Part II and clarified in the inytroduction.

3.12.3.1.4. In order to cover the range of the tyre sizes fitting the commercial vehicles, three Standard Reference Testing Tyre (SRTT) sizes shall be used to measure the relative wet index:

- (a) SRTT 315/70R22.5 LI=154/150, ASTM F2870
- (b) SRTT 245/70R19.5 LI=136/134, ASTM F2871
- (c) SRTT 225/75 R 16 C LI=116/114, ASTM F2872

The three standard reference testing tyre sizes shall be used to measure the relative wet index as shown in the following table:

<i>For C3 tyres</i>	
Narrow family $S_{Nominal} < 285 \text{ mm}$	Wide family $S_{Nominal} \geq 285 \text{ mm}$
SRTT 245/70R19.5 LI=136/134	SRTT 315/70R22.5 LI=154/150
<i>For C2 tyres</i>	
SRTT 225/75 R 16 C LI=116/114	
$S_{Nominal} = \text{Tyre nominal section width}$	

3.12.3.2. Test procedure

The comparative wet grip performance shall be established using either:

- (a) A trailer or special purpose tyre evaluation vehicle; or
- (b) A standard production vehicle (M₂, M₃, N₁, N₂ or N₃, category) as defined in ~~Special Resolution N° 1 concerning the common definitions of vehicle categories, masses and dimensions (S.R.1) contained in ECE/TRANS/WP.29/1045 and subsequent amendments, the Consolidated Resolution on the Construction of Vehicles (R.E.3.) contained in ECE/TRANS/WP.29/78/Rev.3, para. 2.~~

Comment [JN59]: Agreement in GGRF 80th session to refer to S.R.1 instead of R.E.3.

3.12.3.2.1. Trailer or special purpose tyre evaluation vehicle procedure

3.12.3.2.1.1. The measurements are conducted on (a) tyre(s) mounted on a trailer towed by a vehicle or a tyre test vehicle.

The brake on the test position is applied firmly until sufficient braking torque results to produce maximum braking force that will occur prior to wheel lockup at a test speed of 50 km/h. The trailer, together with the towing vehicle, or the tyre evaluation vehicle shall comply with the following requirements:

3.12.3.2.1.1.1. Be capable of exceeding the upper limit for the test speed of 50 km/h and of maintaining the test speed requirement of (50 ± 2) km/h even at the maximum level of application of braking forces;

3.12.3.2.1.1.2. Be equipped with an axle providing one test position having an hydraulic brake and actuation system that can be operated at the test position from the towing vehicle if applicable. The braking system shall be capable of providing sufficient braking torque to achieve the peak brake force coefficient over the range of tyre sizes and tyre loads to be tested;

3.12.3.2.1.1.3. Be capable of maintaining longitudinal alignment (toe) and camber of the test wheel and tyre assembly throughout the test within $\pm 0.5^\circ$ of the static figures achieved at the test tyre loaded condition;

3.12.3.2.1.1.4. In the case a track wetting system is incorporated:

The system shall be able to deliver the water such that the tyre and track surface in front of the tyre are wetted before the start of braking and throughout the duration of the test. The apparatus may be optionally equipped with a pavement-wetting system, less the storage tank, which, in the case of the trailer, is mounted on the tow vehicle. The water being applied to the pavement ahead of the test tyres shall be supplied by a nozzle suitably designed to ensure that the water layer encountered by the test tyre has a uniform cross section at the test speed with a minimum splash and overspray.

The nozzle configuration and position shall ensure that the water jets shall be directed toward the test tyre and pointed toward the pavement at an angle of 15 to 30°. The water shall strike the pavement 0.25 to 0.5 m ahead of the centre of tyre contact. The nozzle shall be located 100 mm above the pavement or the minimum height required to clear obstacles which the tester is expected to encounter, but in no case more than 200 mm above the pavement. The water layer shall be at least 25 mm wider than the test tyre tread and applied so the tyre is centrally located between the edges. The volume of water per unit of wetted width shall be directly proportional to the test speed. The quantity of water applied at 50 km/h shall be 14 l/s per meter of the width of the wetted surface. The nominal values of rate of water application shall be maintained within ± 10 per cent.

3.12.3.2.1.2. Test procedure

3.12.3.2.1.2.1. Fit the test tyres on rims specified by a recognized tyre and rim standards organization as listed in Annex 7. Ensure proper bead seating by the use of a suitable lubricant. Excessive use of lubricant should be avoided to prevent slipping of the tyre on the wheel rim.

Check the test tyres for the specified inflation pressure at ambient temperature (cold), just prior to testing. For the purpose of this standard the testing tyre cold inflation pressure P_t shall be calculated as follows:

$$P_t = P_r \times \left(\frac{Q_t}{Q_r} \right)^{1.2}$$

Where:

P_r = Inflation pressure marked on the sidewall. If P_r is not marked on the sidewall refer to the specified pressure in applicable tyre standards manuals corresponding to maximum load capacity for single applications

Q_t = The static test load of the tyre

Q_r = The maximum mass associated with the load index of the tyre

3.12.3.2.1.2.2. For tyre break-in, two braking runs are performed. The tyre shall be conditioned for a minimum of two hours ~~adjacent to the test track~~ such that it is stabilized at the ambient temperature of the test track

Comment [JN60]: To be deleted (decision during the special GRRF of June 2014)

area. The tyre(s) shall not be exposed to direct sunshine during conditioning.

3.12.3.2.1.2.3. The load conditions for testing shall be 75 ± 5 per cent of the value corresponding to the load index.

3.12.3.2.1.2.4. Shortly before testing, the track shall be conditioned by carrying out at least ten braking test runs at 50 km/h on the part of the track to be used for the performance test programme but using a tyre not involved in that programme;

3.12.3.2.1.2.5. Immediately prior to testing, the tyre inflation pressure shall be checked and reset, if necessary, to the values given in paragraph 3.12.3.2.1.2.1.

3.12.3.2.1.2.6. The test speed shall be at 50 ± 2 km/h and shall be maintained between these limits throughout the test run.

3.12.3.2.1.2.7. The direction of the test shall be the same for each set of tests and shall be the same for the test tyre as that used for the SRTT with which its performance is to be compared.

3.12.3.2.1.2.8. Deliver water to the pavement ahead of the test tyre approximately 0.5 s prior to brake application (for internal watering system). The brakes of the test wheel assembly shall be applied such that peak braking force is achieved within 0.2 s and 1.0 s of brake application.

3.12.3.2.1.2.9. For new tyres, the first two braking runs are discarded for tyre break-in.

3.12.3.2.1.2.10. For the evaluation of the performance of any tyre compared with that of the SRTT, the braking test should be run at the same area on the test pad.

3.12.3.2.1.2.11. The order of testing shall be:

R1 - T - R2

Where:

R1 = the initial test of the SRTT,

R2 = the repeat test of the SRTT and

T = the test of the candidate tyre to be evaluated.

A maximum of three candidate tyres may be tested before repeating the SRTT test, for example:

R1 - T1 - T2 - T3 - R2

3.12.3.2.1.2.12. Calculate the peak braking force coefficient, μ_{peak} , for each test using the following equation:

$$\mu(t) = \left| \frac{f_h(t)}{f_v(t)} \right| \quad (1)$$

Where:

$\mu(t)$ = dynamic tyre braking force coefficient in real time,

$f_h(t)$ = dynamic braking force in real time, N,

Comment [JN61]: Before testing, the track shall be conditioned e.g. by carrying out at least ten braking tests on the part of the track to be used for the performance test programme but using a tyre not involved in that programme. (Special GRRF of June 2014)

$f_v(t)$ = dynamic vertical load in real time, N

Using equation (1) for dynamic tyre braking force coefficient, calculate the peak tyre braking force coefficient, μ_{peak} , by determining the highest value of $\mu(t)$ before lockup occurs. Analogic signals should be filtered to remove noise. Digitally recorded signals may be filtered using a moving average technique.

Calculate the average values of peak-braking coefficient ($\mu_{\text{peak, ave}}$) by averaging four or more valid repeated runs for each set of test and reference tyres for each test condition provided that the tests are completed within the same day.

3.12.3.2.1.2.13. Validation of results

For the reference tyre:

If the coefficient of variation of the peak braking coefficient, which is calculated by "standard deviation/average x 100" of the reference tyre is higher than five per cent, discard all data and repeat the test for this reference tyre.

For the candidate tyres:

The coefficients of variation (standard deviation/average x 100) are calculated for all the candidate tyres. If one coefficient of variation is greater than five per cent, discard the data for this candidate tyre and repeat the test.

If R1 is the average of the peak braking coefficient in the first test of the reference tyre, R2 is the average of the peak braking coefficient in the second test of the reference tyre, the following operations are performed, according to the following table:

<i>If the number of sets of candidate tyres between two successive runs of the reference tyre is:</i>	<i>and the set of candidate tyres to be qualified is:</i>	<i>then "Ra" is calculated by applying the following:</i>
1 R1 – T1 – R2	T1	Ra = 1/2 (R1 + R2)
2 R1 – T1 - T2 – R2	T1 T2	Ra = 2/3 R1 + 1/3 R2 Ra = 1/3 R1 + 2/3 R2
3 R1 – T1 - T2 - T3 – R2	T1 T2 T3	Ra = 3/4 R1 + 1/4 R2 Ra = 1/2 (R1 + R2) Ra = 1/4 R1 + 3/4 R2

3.12.3.2.1.2.14. The wet grip index (G) shall be calculated as:

Wet grip index (G) = $\mu_{\text{peak,ave}}(T) / \mu_{\text{peak,ave}}(R)$

It represents the relative Wet Grip Index for braking performance of the candidate tyre (T) compared to the reference tyre (R).

3.12.3.2.2. Standard vehicle procedure

- 3.12.3.2.2.1. The vehicle used shall have two axles and be equipped with an anti-lock braking system (e.g. standard production vehicle of M₂, M₃, N₁, N₂ or N₃ category). The ABS shall continue to fulfil the utilisation of adhesion requirements defined in the Regulations as appropriate, and shall be comparable and constant throughout the tests with the different tyres mounted.

3.12.3.2.2.1.1. Measuring equipment

The vehicle shall be fitted with a sensor suitable for measuring speed on a wet surface and distance covered between two speeds.

To measure vehicle speed, a fifth wheel or non-contact speed-measuring system shall be used.

The following tolerances shall be respected:

- (a) For the speed measurements: ± 1 per cent or ± 0.5 km/h whichever is greater;
- (b) For the distance measurements: $\pm 1 \times 10^{-1}$ m.

A display of the measured speed or the difference between the measured speed and the reference speed for the test can be used inside the vehicle so that the driver can adjust the speed of the vehicle.

A data acquisition system can be also used for storing the measurements.

3.12.3.2.2.2. Test procedure

Starting with a defined initial speed, the brakes are applied hard enough on the two axles at the same time to activate the ABS system.

3.12.3.2.2.2.1. The Average Deceleration (AD) is calculated between two defined speeds, with an initial speed of 60 km/h and a final speed of 20 km/h.

3.12.3.2.2.2.2. Vehicle equipment

The rear axle may be indifferently fitted with 2 or 4 tyres.

For the reference tyre testing, both axles are fitted with reference tyres. (A total of 4 or 6 reference tyres depending on the choice above mentioned).

For the candidate tyre testing, 3 fitting configurations are possible:

- (a) Configuration "Configuration 1": Candidate tyres on front and rear axles: it is the standard configuration that should be used every time it is possible.
- (b) Configuration "Configuration 2": Candidate tyres on front axle and reference tyre or control tyre on rear axle: allowed in such cases where fitting the candidate tyre on the rear position is not possible.
- (c) Configuration "Configuration 3": Candidate tyres on rear axle and reference tyre or control tyre on front axle: permitted in such cases where fitting the candidate tyre on the front position is not possible.

3.12.3.2.2.2.3. Tyre inflation pressure

- (a) For a vertical load higher or equal to 75 per cent of the load capacity of the tyre, the test inflation pressure " P_t " shall be calculated as follows:

$$P_t = P_r \cdot (Q_t/Q_r)^{1.25}$$

P_r = Inflation pressure marked on the sidewall. If P_r is not marked on the sidewall refer to the specified pressure in applicable tyre standards manuals corresponding to maximum load capacity for single applications

Q_t = static test load of the tyre

Q_r = maximum mass associated with the load index of the tyre

- (b) For a vertical load lower than 75 per cent of the load capacity of the tyre, the test inflation pressure P_t shall be calculated as follows:

$$P_t = P_r \cdot (0.75)^{1.25} = (0.7) \cdot P_r$$

P_r = Inflation pressure marked on the sidewall.

If P_r is not marked on the sidewall refer to the specified pressure in applicable tyre standard manuals corresponding to maximum load capacity for single applications.

Check the tyre pressure just prior to testing at ambient temperature.

3.12.3.2.2.4. Tyre load

The static load on each axle shall remain the same throughout the test procedure. The static load on each tyre shall lie between 60 per cent and 100 per cent of the candidate tyre's load capacity. This value shall not exceed 100 per cent of the load capacity of the reference tyre.

Tyre load on the same axle should not differ by more than 10 per cent.

The use of fitting as per Configurations 2 and 3 shall fulfil the following additional requirements:

Configuration 2: Front axle load > Rear axle load

The rear axle may be indifferently fitted with 2 or 4 tyres

Configuration 3: Rear axle load > Front axle load x 1.8

3.12.3.2.2.5. Tyre preparation and break-in

- 3.12.3.2.2.5.1. The test tyre shall be mounted on the test rim declared by the tyre manufacturer.

Ensure proper bead seating by the use of a suitable lubricant. Excessive use of lubricant should be avoided to prevent slipping of the tyre on the wheel rim.

- 3.12.3.2.2.5.2. Place the fitted test tyres in a location for a minimum of two hours such that they all have the same ambient temperature prior to testing, and shield them from the sun to avoid excessive heating by solar radiation. For tyre break-in, perform two braking runs.

- 3.12.3.2.2.5.3. Condition the pavement by conducting at least ten test runs with tyres not involved in the test programme at an initial speed higher or equal to 65 km/h (which is higher than the initial test speed to guarantee that a sufficient length of track is In the case of a new tyre).

3.12.3.2.2.6. Procedure

- 3.12.3.2.2.6.1. First, mount the set of reference tyres on the vehicle.

The vehicle accelerates in the starting zone up to 65 ± 2 km/h.

Activation of the brakes on the track is made always at the same place with a tolerance of 5 metres in longitudinal and 0.5 metres in transverse.

- 3.12.3.2.2.6.2. According to the type of transmission, two cases are possible:

- (a) Manual transmission

As soon as the driver is in the measuring zone and having reached 65 ± 2 km/h, the clutch is released and the brake pedal depressed sharply, holding it down as long as necessary to perform the measurement.

(b) Automatic transmission

As soon as the driver is in the measuring zone and having reached 65 ± 2 km/h, select neutral gear and then the brake pedal is depressed sharply, holding it down as long as necessary to perform the measurement.

Automatic activation of the brakes can be performed by means of a detection system made of two parts, one indexed to the track and one embarked on the vehicle. In that case braking is made more rigorously at the same portion of the track.

If any of the above-mentioned conditions are not met when a measurement is made (speed tolerance, braking time, etc.), the measurement is discarded and a new measurement is made.

3.12.3.2.2.6.3. Test running order

Examples:

The run order for a test of 3 sets of candidate tyres (T1 to T3) plus a reference tyre R would be:

R - T1 - T2 - T3 - R

The run order for a test of 5 sets of tyres (T1 to T5) plus a reference tyre R would be:

R - T1 - T2 - T3 - R - T4 - T5 - R

3.12.3.2.2.6.4. The direction of the test shall be the same for each set of tests and shall be the same for the candidate test tyre as that used for the SRTT with which its performance is to be compared.

3.12.3.2.2.6.5. For each test and for new tires, the first two braking measurements are discarded.

3.12.3.2.2.6.6. After at least 3 valid measurements have been made in the same direction, the reference tyres are replaced by a set of the candidate tyres (one of the 3 configurations presented in paragraph 3.12.3.2.2.2.) and at least 6 valid measurements shall be performed.

3.12.3.2.2.6.7. A maximum of three sets of candidate tyres can be tested before the reference tyre is re-tested.

3.12.3.2.2.7. Processing of measurement results

3.12.3.2.2.7.1. Calculation of the Average Deceleration (AD)

Each time the measurement is repeated, the average deceleration AD ($\text{m}\cdot\text{s}^{-2}$) is calculated by:

$$AD = \left| \frac{S_f^2 - S_i^2}{2d} \right|$$

Where d (m) is the distance covered between the initial speed S_i ($\text{m}\cdot\text{s}^{-1}$) and the final speed S_f ($\text{m}\cdot\text{s}^{-1}$).

3.12.3.2.2.7.2. Validation of results

For the reference tyre:

If the coefficient of variation of "AD" of any two consecutive groups of 3 runs of the reference tyre is higher than 3 per cent, discard all data and repeat the test for all tyres (the candidate tyres and the reference tyre). The coefficient of variation is calculated by the following relation:

$$\frac{\text{standard deviation}}{\text{average}} \times 100$$

For the candidate tyres:

The coefficients of variation are calculated for all the candidate tyres.

$$\frac{\text{standard deviation}}{\text{average}} \times 100$$

If one coefficient of variation is greater than 3 per cent, discard the data for this candidate tyre and repeat the test.

3.12.3.2.2.7.3. Calculation of the "average AD"

If R1 is the average of the AD values in the first test of the reference tyre and R2 is the average of the AD values in the second test of the reference tyre, the following operations are performed, according to Table 1.

Ra is the adjusted average AD of the reference tyre.

Table 1

<i>Number of sets of candidate tyres between two successive runs of the reference tyre</i>	<i>Set of candidate tyres to be qualified</i>	<i>Ra</i>
1 R1-T1-R2	T1	Ra = 1/2 (R1 + R2)
2 R1-T1-T2-R2	T1 T2	Ra = 2/3 R1 + 1/3 R2 Ra = 1/3 R1 + 2/3 R2
3 R1-T1-T2-T3-R2	T1 T2 T3	Ra = 3/4 R1 + 1/4 R2 Ra = 1/2 (R1 + R2) Ra = 1/4 R1 + 3/4 R2

3.12.3.2.2.7.4. Calculation of braking force coefficient, BFC

BFC(R) and BFC(T) are calculated according to Table 2:

Table 2

<i>Tyre type</i>	<i>Braking force coefficient is</i>
Reference tyre	BFC(R) = Ra/g
Candidate tyre	BFC(T) = Ta/g
g is the acceleration due to gravity (rounded to 9.81 m·s⁻²).	

Ta (a = 1, 2, etc.) is the average of the AD values for a test of a candidate tyre.

3.12.3.2.2.7.5. Calculation of the relative wet grip performance index of the tyre

The Wet grip index represents the relative performance of the candidate tyre compared to the reference tyre. The way to obtain it depends on the

test configuration as defined in paragraph 3.12.3.2.2.2.2. The wet grip index of the tyre is calculated as reported into Table 3:

Table 3

<p>Configuration C1: candidate tyres on both axles</p>	$Wet\ Grip\ Index = \frac{BFC(T)}{BFC(R)}$
<p>Configuration C2: candidate tyres on front axle and reference tyres on rear axle</p>	$Wet\ Grip\ Index = \frac{(BFC(T) \cdot [a + b + h \cdot BFC(R)] - a \cdot BFC(R))}{BFC(R) \cdot [b + h \cdot BFC(T)]}$
<p>Configuration C3: reference tyres on front axle and candidate tyres on rear axle</p>	$Wet\ Grip\ Index = \frac{(BFC(T) \cdot [-a - b + h \cdot BFC(R)] + b \cdot BFC(R))}{BFC(R) \cdot [-a + h \cdot BFC(T)]}$

Where:

- "G": centre of gravity of the loaded vehicle
 - "m": mass (in kilograms) of the loaded vehicle
 - "a": horizontal distance between front axle and centre of gravity of the loaded vehicle (m)
 - "b": horizontal distance between rear axle and centre of gravity of the loaded vehicle
 - "h": vertical distance between ground level and centre of gravity of the loaded vehicle (m).
- N.B.* When "h" is not precisely known, these worst case values shall apply: 1.2 for configuration C2, and 1.5 for configuration C3
- "γ" loaded vehicle acceleration (m·s⁻²)
 - "g" acceleration due to the gravity (m·s⁻²)
 - "X1" longitudinal (X-direction) reaction of the front tyre on the road
 - "X2" longitudinal (X-direction) reaction of the rear tyre on the road
 - "Z1" normal (Z-direction) reaction of the front tyre on the road
 - "Z2" normal (Z-direction) reaction of the rear tyre on the road

Figure 1
Nomenclature explanation related to grip index of the tyre

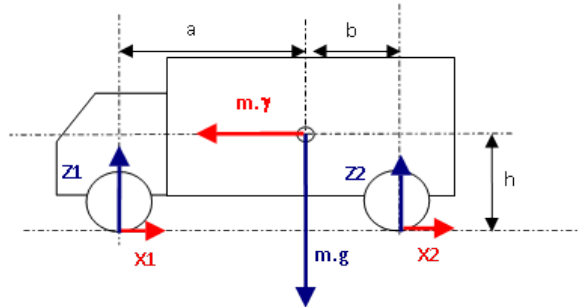

3.12.3.2.2.2.8. Wet grip performance comparison between a candidate tyre and a reference tyre using a control tyre

When the candidate tyre size is significantly different from the reference tyre, a direct comparison on the same vehicle may be not possible. This approach uses an intermediate tyre, hereinafter called the control tyre.

3.12.3.2.2.2.8.1. The principle lies upon the use of a control tyre and 2 different vehicles for assessing a candidate tyre in comparison with a reference tyre.

One vehicle can fit the reference tyre and the control tyre, the other the control tyre and the candidate tyre. All conditions are in conformity with paragraphs 3.12.3.2.2.1.2. to 3.12.3.2.2.2.5. above.

3.12.3.2.2.2.8.2. The first assessment is a comparison between the control tyre and the reference tyre. The result (Wet Grip Index 1) is the relative efficiency of the control tyre compared to the reference tyre.

3.12.3.2.2.2.8.3. The second assessment is a comparison between the candidate tyre and the control tyre. The result (Wet Grip Index 2) is the relative efficiency of the candidate tyre compared to the control tyre.

The second assessment is done on the same track as the first one and within one week maximum. The wetted surface temperature shall be in the range of $\pm 5^{\circ}\text{C}$ of the temperature of the first assessment. The control tyre set (4 or 6 tyres) is physically the same set as the set used for the first assessment.

3.12.3.2.2.2.8.4. The wet grip index of the candidate tyre compared to the reference tyre is deduced by multiplying the relative efficiencies calculated above:

$$(\text{Wet Grip Index 1} \cdot \text{Wet Grip Index 2})$$

Note: When the test expert decides to use an SRTT tyre as a control tyre (i.e. in the test procedure two SRTTs are compared directly instead of an SRTT with a control tyre) the result of the comparison between the SRTTs is called the "local shift factor".

It is permitted to use a previous SRTTs comparison.

The comparison results shall be checked periodically.

3.12.3.2.2.2.8.5. Selection of a set of tyres as a control tyre set

A "control tyre" set is a group of identical tyres made in the same factory during a one week period.

3.12.3.2.2.2.8.6. Reference and control tyres

Before the first assessment (control tyre / reference tyre), normal storage conditions can be used. It is necessary that all the tyres of a control tyre set have been stored in the same conditions.

3.12.3.2.2.2.8.7. Storage of control tyres

As soon as the control tyre set has been assessed in comparison with the reference tyre, specific storage conditions shall be applied for control tyres replacement.

3.12.3.2.2.2.8.8. Replacement of reference and control tyres

When irregular wear or damage results from tests, or when wear influences the test results, the use of the tyre shall be discontinued.

~~3.12.2. General test conditions~~

~~3.12.2.1. Track characteristics~~

~~3.12.2.1.1. The track shall have a dense asphalt surface with a gradient in any direction not exceeding 2 per cent. It shall be of uniform age, composition, and wear and shall be free of loose material or foreign deposits. The maximum chipping size shall be 10 mm (tolerances permitted from 8 mm to 13 mm) and the sand depth measured as specified in ASTM standard E 965-96 (2006) shall be 0.7 ± 0.3 mm.~~

~~The surface friction value for the wetted track shall be established by one or other of the following methods:~~

~~3.12.2.1.1.1. Standard Reference Test Tyre (SRTT) method~~

~~When tested using the SRTT and the method given in paragraph 3.12.3.1. the average peak brake force coefficient (pbfc) shall be between 0.6 and 0.8. The measured values shall be corrected for the effects of temperature as follows:~~

$$\text{pbfc} = \text{pbfc (measured)} + 0.0035 (t - 20)$$

~~Where "t" is the wetted track surface temperature in degrees Celsius.~~

~~The test shall be conducted using the lanes and length of the track to be used for the wet grip test;~~

~~3.12.2.1.1.2. British Pendulum Number (BPN) method~~

~~The averaged British Pendulum Number (BPN) of the wetted track, measured in accordance with the procedure given in the ASTM standard E 303-93 (2008) and using the pad as specified in ASTM standard E 501-08, shall be between 40 and 60 after temperature correction. Unless temperature correction recommendations are indicated by the pendulum manufacturer, the following formula can be used:~~

$$\text{BPN} = \text{BPN (measured value)} + 0.34 * t - 0.0018 * t^2 - 6.1$$

~~Where "t" is the wetted track surface temperature in degrees Celsius.~~

~~In the lanes of the track to be used during the wet grip tests, the BPN shall be measured at intervals of 10 m along the length of the lanes. The BPN shall be measured 5 times at each point and the coefficient of variation of the BPN averages shall not exceed by 10 per cent.~~

~~3.12.2.2. It shall be established prior to testing that the characteristics of the test track comply with paragraph 3.12.2.1 on the basis of evidence produced in test reports.~~

~~3.12.2.3. Wetting conditions~~

~~The surface may be wetted from the track side or by a wetting system incorporated into the test vehicle or the trailer.~~

~~If a track side system is used, the test surface shall be wetted for at least half an hour prior to testing in order to equalize the surface temperature and water temperature. It is recommended that track side wetting be continuously applied throughout testing.~~

~~For either wetting method, the water depth shall be between 0.5 mm and 1.5 mm.~~

~~3.12.2.4. The wind conditions shall not interfere with wetting of the surface (wind shields are permitted).~~

~~The wetted surface temperature shall be between 5 °C and 35 °C and shall not vary during the test by more than 10 °C.~~

~~3.12.3. Test procedures~~

~~The comparative wet grip performance shall be established using either:~~

~~(a) A trailer or special purpose tyre evaluation vehicle; or~~

~~(b) A standard production passenger carrying vehicle of Category 1-4 vehicle as defined in Special Resolution No. 1.¹²~~

~~3.12.3.1. Trailer or special purpose tyre evaluation vehicle procedure~~

~~3.12.3.1.1. The trailer, together with the towing vehicle, or the tyre evaluation vehicle shall comply with the following requirements:~~

~~3.12.3.1.1.1. Be capable of exceeding the upper limit for the test speed of 67 km/h and of maintaining the test speed requirement of 65 ± 2 km/h at the maximum level of application of braking forces;~~

~~3.12.3.1.1.2. Be equipped with an axle providing one test position having an hydraulic brake and actuation system that can be operated from the towing vehicle if applicable. The braking system shall be capable of providing sufficient braking torque to achieve the peak brake force coefficient over the range of tyre sizes and tyre loads to be tested;~~

~~3.12.3.1.1.3. Be capable of maintaining longitudinal alignment (toe) and camber of the test wheel and tyre assembly throughout the test within $\pm 0.5^\circ$ of the static figures achieved at the test tyre loaded condition;~~

~~3.12.3.1.1.4. In the case of a trailer, the mechanical coupling device between the towing vehicle and trailer shall be such that, when the towing vehicle and trailer are coupled together, the drawbar, or part of the drawbar, of a trailer that incorporates the braking force measurement sensing is horizontal or slopes downwards from rear to front at a maximum angle of 5°. The longitudinal distance from the centre line of the articulation point of the coupling (hitch) to the transverse centre line of the axle of the trailer shall be at least ten times the coupling (hitch) height;~~

¹² Document ECE/TRANS/WP.29/1045, as amended.

- ~~3.12.3.1.1.5. In the case of vehicles that incorporate a track wetting system, the water delivery nozzle(s) shall be such that the resulting water film is of uniform section extending at least 25 mm beyond the width of the tyre contact patch. The nozzle(s) shall be directed downwards at an angle of 20° to 30° with the water contacting the track surface between 250 mm and 450 mm in front of the centre of the tyre contact patch. The height of the nozzle(s) shall be 25 mm or the minimum to avoid any obstacles on the track surface without exceeding a maximum of 100 mm. Water delivery rate shall ensure a water depth of 0.5 mm to 1.5 mm and shall be consistent throughout the test to within ±10 per cent. Note that a typical rate for testing at 65 km/h will be 18 litres per second per metre of wetted track surface width.~~
- ~~The system shall be able to deliver the water such that the tyre, and track surface in front of the tyre, is wetted before the start of braking and throughout the duration of the test.~~
- ~~3.12.3.1.2. Test procedure for trailer or special purpose vehicle~~
- ~~3.12.3.1.2.1. The test tyre shall be trimmed to remove any moulding protrusions that are likely to affect the test.~~
- ~~3.12.3.1.2.2. The test tyre shall be mounted on the test rim declared by the tyre manufacturer and shall be inflated to 180 kPa in the case of the SRTT and standard load tyre or 220 kPa in the case of an extra load tyre.~~
- ~~3.12.3.1.2.3. The tyre shall be conditioned for a minimum of two hours such that it is stabilized at the ambient temperature of the test track area. The tyre(s) shall not be exposed to direct sunshine during conditioning.~~
- ~~3.12.3.1.2.4. The tyre shall be loaded to:~~
- ~~(a) Between 445 kg and 508 kg in the case of the SRTT; and~~
 - ~~(b) Between 70 per cent and 80 per cent of the load value corresponding to the load index of the tyre in any other case.~~
- ~~3.12.3.1.2.5. Before testing, the track shall be conditioned e.g. by carrying out at least ten braking tests on the part of the track to be used for the performance test programme but using a tyre not involved in that programme.~~
- ~~3.12.3.1.2.6. Immediately prior to testing, the tyre inflation pressure shall be checked and reset, if necessary, to the values given in paragraph 3.12.3.1.2.2.~~
- ~~3.12.3.1.2.7. The test speed shall be between 63 km/h and 67 km/h and shall be maintained between these limits throughout the test run.~~
- ~~3.12.3.1.2.8. The direction of the test shall be the same for each set of tests and shall be the same for the test tyre as that used for the SRTT with which its performance is to be compared.~~
- ~~3.12.3.1.2.9. The brakes of the test wheel assembly shall be applied such that peak braking force is achieved within 0.2 s and 0.5 s of brake application.~~
- ~~3.12.3.1.2.10. In the case of a new tyre, at least two test runs shall be carried out to condition the tyre. These tests may be used to check the operation of the recording equipment but the results shall not be taken into account in the performance assessment.~~
- ~~3.12.3.1.2.11. For the evaluation of the performance of any tyre compared with that of the SRTT, the braking test shall be carried out from the same point and in the same lane of the test track.~~

3.12.3.1.2.12. The order of testing shall be:

~~R1 — T — R2~~

Where:

~~R1 is the initial test of the SRTT, R2 is the repeat test of the SRTT and T is the test of the candidate tyre to be evaluated.~~

~~A maximum of three candidate tyres may be tested before repeating the SRTT test, for example:~~

~~R1 — T1 — T2 — T3 — R2~~

3.12.3.1.2.13. The average value of peak brake force coefficient (pbfc) shall be calculated over at least six valid results. For results to be considered to be valid, the coefficient of variation as determined by the standard deviation divided by the average result, expressed as a percentage, shall be within 5 per cent. If this cannot be achieved with the repeat testing of the SRTT, the evaluation of the candidate tyre(s) shall be discarded and the entire order of testing shall be repeated. However, if only the candidate tyre(s) test is invalid, the entire test series need not be deemed invalid.

3.12.3.1.2.14. Using the value of the average pbfc for each series of test runs:

In the case of the order of testing ~~R1 — T — R2~~, the pbfc of the SRTT to be used in the comparison of the performance of the candidate tyre shall be taken to be:

~~$(R1 + R2)/2$~~

Where:

~~R1 is the average pbfc for the first series of test runs of the SRTT and R2 is the average pbfc for the second series of test runs of the SRTT.~~

In the case of the order of testing ~~R1 — T1 — T2 — R2~~, the pbfc of the SRTT shall be taken to be:

~~$2/3 R1 + 1/3 R2$ for comparison with the candidate tyre T1 and~~

~~$1/3 R1 + 2/3 R2$ for comparison with the candidate tyre T2~~

In the case of the order of testing ~~R1 — T1 — T2 — T3 — R2~~, the pbfc of the SRTT shall be taken to be:

~~$3/4 R1 + 1/4 R2$ for comparison with the candidate tyre T1~~

~~$(R1 + R2)/2$ for comparison with the candidate tyre T2 and~~

~~$1/4 R1 + 3/4 R2$ for comparison with the candidate tyre T3~~

3.12.3.1.2.15. The wet grip index (G) shall be calculated as:

$$G = \frac{\text{pbfc of candidate tyre}}{\text{pbfc of SRTT}}$$

~~3.12.3.2. Standard vehicle procedure~~

~~3.12.3.2.1. The vehicle shall be a standard Category 1-1 vehicle as defined in Special Resolution No. 1,¹² capable of a minimum speed of 90 km/h and equipped with an anti-lock braking system (ABS).~~

~~3.12.3.2.1.1. The vehicle shall not be modified except:~~

- ~~(a) To allow the fitting of an increased range of wheel and tyre sizes;~~
- ~~(b) To allow mechanical (including hydraulic, electrical or pneumatic) operation of the service brake control. The system may be operated automatically by signals from devices incorporated in, or adjacent to, the track.~~

~~3.12.3.2.2. Test procedure using standard vehicle~~

~~3.12.3.2.2.1. The test tyres shall be trimmed to remove any moulding protrusions that are likely to affect the test.~~

~~3.12.3.2.2.2. The test tyre shall be mounted on the test rim declared by the tyre manufacturer and shall be inflated to 220 kPa in all cases.~~

~~3.12.3.2.2.3. The tyre shall be conditioned for a minimum of two hours adjacent to the test track such that it is stabilized at the ambient temperature of the test track area. The tyre(s) shall not be exposed to direct sunshine during conditioning.~~

~~3.12.3.2.2.4. The static load on the tyre shall be:~~

- ~~(a) Between 381 kg and 572 kg in the case of the SRTT; and~~
- ~~(b) Between 60 per cent and 90 per cent of the load value corresponding to the load index of the tyre in any other case.~~

~~The variation in load on tyres on the same axle shall be such that the load borne by the more lightly loaded tyre shall not be less than 90 per cent of that of the tyre bearing the greater load.~~

~~3.12.3.2.2.5. Shortly before testing, the track shall be conditioned by carrying out at least ten braking tests from 90 km/h to 20 km/h on the part of the track to be used for the performance test programme but using tyres not involved in that programme.~~

~~3.12.3.2.2.6. Immediately prior to testing, the tyre inflation pressure shall be checked and reset, if necessary, to the values given in paragraph 3.12.3.2.2.2.~~

~~3.12.3.2.2.7. Starting from an initial speed of between 87 km/h and 83 km/h, a constant force sufficient to cause operation of the ABS on all wheels of the vehicle and to result in stable deceleration of the vehicle prior to the speed being reduced to 80 km/h, shall be applied to the service brake control and this force shall be maintained until the vehicle has been brought to rest.~~

~~The braking test shall be carried out with the clutch of a manual transmission disengaged or with the selector of an automatic transmission in the neutral position.~~

~~3.12.3.2.2.8. The direction of the test shall be the same for each set of tests and shall be the same for the candidate test tyre as that used for the SRTT with which its performance is to be compared.~~

¹² Document ECE/TRANS/WP.29/1045, as amended.

~~3.12.3.2.2.9. In the case of new tyres, two test runs shall be carried out to condition the tyres. These tests may be used to check the operation of the recording equipment but the results shall not be taken into account in the performance assessment.~~

~~3.12.3.2.2.10. For the evaluation of the performance of any tyre compared with that of the SRTT, the braking test shall be carried out from the same point and in the same lane of the test track.~~

~~3.12.3.2.2.11. The order of testing shall be:~~

~~R1 — T — R2~~

~~Where:~~

~~R1 is the initial test of the SRTT, R2 is the repeat test of the SRTT and T is the test of the candidate tyre to be evaluated.~~

~~A maximum of three candidate tyres may be tested before repeating the SRTT test, for example:~~

~~R1 T1 — T2 — T3 — R2~~

~~3.12.3.2.2.12. The mean fully developed deceleration (mfdd) between 80 km/h and 20 km/h shall be calculated for at least three valid results in the case of the SRTT and 6 valid results in the case of the candidate tyres.~~

~~The mean fully developed deceleration (mfdd) is given by:~~

$$\text{mfdd} = 231.48 / S$$

~~Where:~~

~~S is the measured stopping distance in metres between 80 km/h and 20 km/h.~~

~~For results to be considered to be valid, the coefficient of variation as determined by the standard deviation divided by the average result, expressed as a percentage, shall be within 3 per cent. If this is cannot achieved with the repeat testing of the SRTT, the evaluation of the candidate tyre(s) shall be discarded and the entire order of testing shall be repeated.~~

~~The average of the calculated values of mfdd shall be determined for each series of test runs.~~

~~3.12.3.2.2.13. Using the value of the average mfdd for each series of test runs:~~

~~In the case of the order of testing R1 — T — R2, the mfdd of the SRTT to be used in the comparison of the performance of the candidate tyre shall be taken to be:~~

$$(R1 + R2) / 2$$

~~Where:~~

~~R1 is the average mfdd for the first series of test runs of the SRTT and R2 is the average mfdd for the second series of test runs of the SRTT~~

~~In the case of the order of testing R1 — T1 — T2 — R2, the mfdd of the SRTT shall be taken to be:~~

$$2/3 R1 + 1/3 R2 \text{ for comparison with the candidate tyre T1; and}$$

$$1/3 R1 + 2/3 R2 \text{ for comparison with the candidate tyre T2.}$$

~~In the case of the order of testing R1 — T1 — T2 — T3 — R2, the mfdd of the SRTT shall be taken to be:~~

~~3/4 R1 + 1/4 R2 for comparison with the candidate tyre T1;
 (R1 + R2)/2 for comparison with the candidate tyre T2; and
 1/4 R1 + 3/4 R2 for comparison with the candidate tyre T3.~~

~~3.12.3.2.2.14. The wet grip index (G) shall be calculated as:~~

$$G = \frac{\text{average mfdd of candidate tyre}}{\text{mfdd of SRTT}}$$

~~3.12.3.2.2.15. In the case where the candidate tyres cannot be fitted to the same vehicle as the SRTT, for example, due to tyre size, inability to achieve required loading and so on, comparison shall be made using intermediate tyres, hereinafter referred to as "control tyres", and two different vehicles. One vehicle shall be capable of being fitted with the SRTT and the control tyre and the other vehicle shall be capable of being fitted with the control tyre and the candidate tyre.~~

~~3.12.3.2.2.15.1. The wet grip index of the control tyre relative to the SRTT (G1) and of the candidate tyre relative to the control tyre (G2) shall be established using the procedure in paragraphs 3.12.3.2.2.1. to 3.12.3.2.2.15.~~

~~The wet grip index of the candidate tyre relative to the SRTT shall be the product of the two resulting wet grip indices that is G1 x G2.~~

~~3.12.3.2.2.15.2. The track, and the portion of the track, shall be the same for all of the tests and the ambient conditions shall be comparable, for example, the surface temperature of the wetted track shall be within ±5 °C. All tests shall be completed within the same day.~~

~~3.12.3.2.2.15.3. The same set of control tyres shall be used for comparison with the SRTT and with the candidate tyre and shall be fitted in the same wheel positions.~~

~~3.12.3.2.2.15.4. Control tyres that have been used for testing shall subsequently be stored under the same conditions as required for the SRTT.~~

~~3.12.3.2.2.16. The SRTT and control tyres shall be discarded if there is irregular wear or damage or when the performance appears to have deteriorated.~~

~~3.12.4. Test report: Annex 9 to this regulation shows the test report that may be used to record the results of the tests.]~~

3.13. Procedure to assess the flat tyre running mode of run flat tyres

For run flat tyres identified by means of letter code "RF" within the size designation a load/speed test shall be carried out as specified in paragraph 3.13.1. below.

A run flat tyre tested in accordance with paragraph 3.13.1. shall be deemed to have passed the test if the tread remains connected to the two sidewalls and the deflected section height does not alter by a value greater than 20 per cent when compared to the deflected section height at the start of the test.

3.13.1. Test procedure

3.13.1.1. Mount a new tyre on the test rim specified by the manufacturer.

3.13.1.2. Condition the tyre at 35 ± 3 °C and 250 kPa for three hours.

3.13.1.3. Remove the valve core and wait until the tyre deflates completely.

3.13.1.4. Mount the tyre-and-wheel assembly to a test axle and press it against the outer surface of a smooth wheel 1.70 m ± 1 per cent or 2.0 m ± 1 per cent in diameter.

- 3.13.1.5. Apply to the test axle a load equal to 65 per cent of the maximum load rating corresponding to the load index of the tyre.
- 3.13.1.6. At the start of the test, measure the deflected section height (Z1).
- 3.13.1.7. During the test the temperature of the test room shall be maintained at 35 ± 3 °C.
- 3.13.1.8. Carry the test through, without interruption in conformity with the following particulars:
Time taken to pass from zero speed to constant test speed: 5 minutes;
Test speed: 80 km/h; Duration of test at the test speed: 60 minutes.
- 3.13.1.9. At the end of the test, measure the deflected section height (Z2).
- 3.13.1.10. Calculate the change in per cent of the deflected section height compared to the deflected section height at the start of the test as $((Z1 - Z2) / Z1) 100$.

3.14. Strength test for LT/C tyres

3.14.1. Requirements

When tested according to the procedure described in this section, LT/C tyres shall have an average strength of not less than the values shown in the table below¹⁴

Load range	Minimum breaking energy	
	Joules (J)	Inch-pounds (in-lbs)
B	293	2600
C	361	3200
D	514	4550
E	576	5100

Comment [JN62]: Tyres with Load range above E tyres have no requirements in this gtr. Therefore the footnote should be deleted.

3.14.2. Preparation of tyre

Mount the tyre on a model rim assembly and inflate it to the pressure corresponding to the maximum load, or maximum dual load where there is both a single and dual load marked on the tyre. If the tyre is tubeless, a tube may be inserted to prevent loss of air during the test in the event of puncture.

Condition it at ambient room temperature for at least 3 hours and readjust the inflation pressure if necessary.

3.14.3. Test procedure

- 3.14.3.1. Force a 19.05 mm (0.75 inch) diameter cylindrical steel plunger with a hemispherical end perpendicularly into the tread rib as near to the centreline as possible, avoiding penetration into the tread pattern groove, at the rate of 50 mm (2 inches) per minute.

Comment [JN63]: Revision 3 – Amendment 3 of Reg.30
Supplement 17 to the 02 series of amendments - Date of entry into force: 27 January 2013
Document ECE/TRANS/WP29/2012/48 as amended by para. 50 of the report 157th session June 2012.

¹⁴ Contracting Parties who utilize load ranges higher than E for LT may apply national requirements.

- 3.14.3.2. Record the force and penetration at five test points equally spaced around the circumference of the tyre. If the tyre fails to break before the plunger is stopped by reaching the rim, record the force and penetration as the rim is reached and use these values in paragraph 3.14.3.3.
- 3.14.3.3. Compute the breaking energy for each test point by means of one of the two following formulas:

$$W = ((F P)/2) 10^{-3}$$
 Where:
 W = Energy, in Joules;
 F = Force, in Newtons; and
 P = Penetration, in mm;
 or

$$W = ((F P)/2)$$
 Where:
 W = Energy, in inch-pounds;
 F = Force, in pounds; and
 P = Penetration, in inches.
- 3.14.3.4. Determine the breaking energy value for the tyre by computing the average of the five values obtained in accordance with paragraph 3.14.3.3.
- 3.15. Tubeless tyre bead unseating resistance test for LT/C tyres with rim codes of 10 or greater
- 3.15.1. Requirements
 When a tubeless LT/C tyre is tested in accordance with the procedure described in this section, the applied force required to unseat the tyre bead at the point of contact shall be not less than:
- (a) 6670 N (1500 pounds) for tyres with a nominal section width of less than 160 mm (6 inches);
 - (b) 8890 N (2000 pounds) for tyres with a nominal section width of 160 mm (6 inches) or more but less than 205 mm (8 inches);
 - (c) 11120 N (2500 pounds) for tyres with a nominal section width of 205 mm (8 inches) or more.
- 3.15.2. Preparation of tyre-wheel assembly
- 3.15.2.1. Wash the tyre, dry it at the beads, and mount it without lubrication or adhesives on a clean, painted test rim.
- 3.15.2.2. Inflate it to the applicable pressure specified in the following table at ambient room temperature:
 For LT/C tyres, the maximum permissible inflation pressure to be used for the bead unseating test is as follows:

<i>Load range</i>	<i>Test pressure</i>
Load range C	260 kPa
Load range D	340 kPa
Load range E	410 kPa

For LT/C tyres with a nominal cross section greater than 295 mm (11.5 inches), the maximum permissible inflation pressure to be used for the bead unseating test is as follows:

<i>Load range</i>	<i>Test pressure</i>
Load range C	190 kPa
Load range D	260 kPa
Load range E	340 kPa

- 3.15.2.3. Mount the wheel and tyre in a fixture shown in Figure 6, and force the bead unseating block shown in Figure 7 or Figure 8 against the tyre sidewall as required by the geometry of the fixture.

Figure 6
Bead Unseating Fixture (all dimension in mm) and table of "A" dimensions

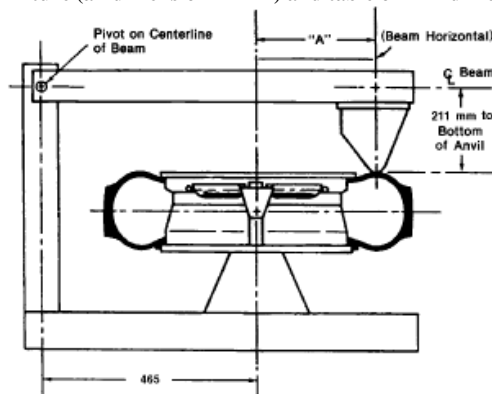

<i>Table of A dimension for different rim codes</i>		
<i>Rim code</i>	<i>mm</i>	<i>Inches</i>
20	345	13.50
19	330	13.00
18	318	12.50
17	305	12.00
16	292	11.50
15	279	11.00
14	267	10.50
13	254	10.00
12	241	9.50

Table of A dimension for different rim codes		
Rim code	mm	Inches
11	229	9.00
10	216	8.50
320	216	8.50
340	229	9.00
345	235	9.25
365	248	9.75
370	254	10.00
390	279	11.00
415	292	11.50

Figure 7
Diagram of bead unseating block (all dimensions in mm)

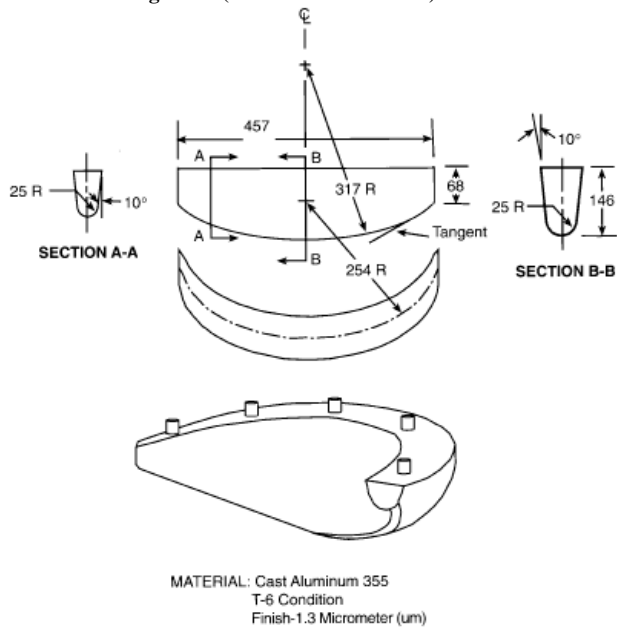
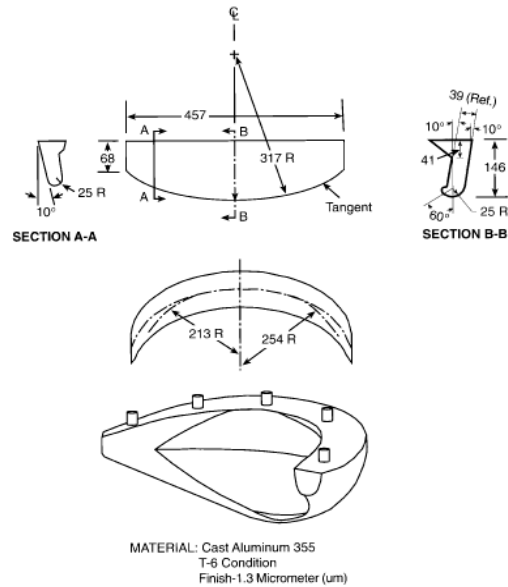

Figure 8
Diagram of bead unseating block (all dimensions in mm)



- 3.15.3. Test procedure
- 3.15.3.1. Apply a load through the block to the tyre's outer sidewall at the distance specified in Figure 6 for the applicable wheel size at a rate of 50 mm (2 inches) per minute, with the load arm substantially parallel to the tyre and rim assembly at the time of engagement.
- 3.15.3.2. Increase the load until the bead unseats or the applicable value specified in paragraph 3.15.1. is reached.
- 3.15.3.3. Repeat the test at least four places equally spaced around the tyre circumference.
- 3.15.3.4. Increase the load until the bead unseats or the applicable value specified in paragraph 3.15.1. is reached.
- 3.15.3.5. Repeat the test at least four places equally spaced around the tyre circumference.
- 3.16. Load/speed endurance test for LT/C tyres¹⁵
- 3.16.1. Requirements
- 3.16.1.1. Each type of LT/C tyre shall undergo at least one load/speed endurance test carried out by the procedure described below.
- 3.16.1.2. A LT/C tyre which, after undergoing the endurance test, does not exhibit any tread separation, ply separation, cord separation, chunking or broken cords shall be deemed to have passed the test.

¹⁵ From Regulation No. 54

- 3.16.1.3. The outer diameter of the tyre, measured six hours after the load/speed endurance test, shall not differ by more than ± 3.5 per cent from the outer diameter as measured before the test.
- 3.16.1.4. If the load/speed combination for the tyre is given in the table in Annex 5, the endurance test prescribed in paragraph 3.16. above need not be carried out for load and speed values other than the nominal values.
- 3.16.1.5. In the case of a tyre which has a load/speed combination in addition to the one that is subject to the variation of load with speed given in the table in Annex 5 to this Regulation, the endurance test prescribed in paragraph 3.16. above shall also be carried out on a second tyre of the same type at the additional load/speed combination.
- 3.16.2. Preparing the tyre
 - 3.16.2.1. Mount a new tyre on the test rim specified by the manufacturer.
 - 3.16.2.2. Use a new inner tube or combination of inner tube, valve and flap (as required) when testing tyres with inner tubes.
 - 3.16.2.3. Inflate the tyre to the pressure corresponding to the pressure index specified by the manufacturer.
 - 3.16.2.4. Condition the tyre-and-wheel assembly at test-room temperature for not less than three hours.
 - 3.16.2.5. Readjust the tyre pressure to that specified in paragraph 3.16.2.3. above.
- 3.16.3. Test procedure
 - 3.16.3.1. Mount the tyre-and-wheel assembly on the test axle and press it against the outer face of a smooth power-driven test drum 1.70 m \pm 1 per cent in diameter having a surface at least as wide as the tyre tread.
 - 3.16.3.2. Apply to the test axle a series of test loads expressed in per cent of the load carrying capacity of the tyre, in accordance with the test programme shown in paragraph 3.16.4.7. below. Where the tyre has load indices for both single and twinned utilization, the reference load for single utilization shall be taken as the basis for the test loads.
 - 3.16.3.3. In the case of tyres with a speed symbol Q and above, test procedures are as specified in paragraph 3.16.4.
 - 3.16.3.3.1. For all other tyre types, the endurance test programme is shown in paragraph 3.16.4.7.
 - 3.16.3.4. The tyre pressure shall not be corrected throughout the test and the test load shall be kept constant throughout each of the three test stages.
 - 3.16.3.5. During the test the temperature in the test-room shall be maintained at between 20 °C and 30 °C or at a higher temperature if the manufacturer so agrees.
 - 3.16.3.6. The endurance-test programme shall be carried out without interruption.
 - 3.16.4. Load/speed test programme for tyre with speed symbol Q and above
 - 3.16.4.1. This programme applies to:
 - 3.16.4.1.1. All tyres marked with load index in single 121 or less.

- 3.16.4.1.2. Tyres marked with load index in single 122 and above and with the additional marking "C", or "LT", referred to in paragraph 3.3.14. of this regulation.
- 3.16.4.2. Load placed on the wheel as a percentage of the load corresponding to the load index:
- 3.16.4.2.1. 90 per cent when tested on a test drum 1.70 m \pm 1 per cent in diameter;
- 3.16.4.2.2. 92 per cent when tested on a test drum 2.0 m \pm 1 per cent in diameter.
- 3.16.4.3. Initial test speed: speed corresponding to the speed symbol less 20 km/h;
- 3.16.4.3.1. Time to reach the initial test speed: 10 min.
- 3.16.4.3.2. Duration of the first step = 10 min.
- 3.16.4.4. Second test speed: speed corresponding to the speed symbol less 10 km/h;
- 3.16.4.4.1. Duration of the second step = 10 min.
- 3.16.4.5. Final test speed: speed corresponding to the speed symbol:
- 3.16.4.5.1. Duration of the final step = 30 min.
- 3.16.4.6. Total test duration: 1 h.
- 3.16.4.7. Endurance test programme

Load index	Tyre speed symbol	Test-drum speed (min^{-1})	Load placed on the wheel as a percentage of the load corresponding to the load index		
			7 h	16 h	24 h
122 or more	F	100	66 %	84 %	101 %
	G	125			
	J	150			
	K	175			
	L	200			
121 or less	M	225	70 % <u>4 h</u>	88 % <u>6 h</u>	106 %
	F	100			
	G	125			
	J	150			
	K	175			
	L	200			
	M	250			
N	275	75 %	97 %	114 %	
P	300	75 %	97 %	114 %	

Special use tyres (marked "ET" or "ML" or "MPT") should be tested at a speed equal to 85 per cent of the speed prescribed for equivalent normal tyres.

- 3.17. Endurance test for LT/C tyres¹⁶
- 3.17.1. Requirements
- 3.17.1.1. When the tyre is tested in accordance with paragraph 3.17.3.:

¹⁶ From FMVSS 139

- (a) There shall be no visual evidence of tread, sidewall, ply, cord, belt or bead separation, chunking, open splices, cracking or broken cords.
- (b) The tyre pressure, when measured at any time between 15 minutes and 25 minutes after the end of the test, shall not be less than 95 per cent of the initial pressure specified in paragraph 3.17.2.1.

3.17.2. Preparation of tyre

3.17.2.1. Mount the tyre on a test rim and inflate it to the pressure specified for the tyre in the following table:

<i>Light truck tyres with a nominal section width ≤ 295 mm (11.5 inches)</i>	
<i>Tyre application</i>	<i>Test pressure (kPa)</i>
Load range C	260
Load range D	340
Load range E	410
<i>Light truck tyres with a nominal section width > 295 mm (11.5 inches)</i>	
Load range C	190
Load range D	260
Load range E	340

- 3.17.2.2. Condition the assembly at 35 ± 3 °C for not less than 3 hours.
- 3.17.2.3. Readjust the pressure to the value specified in paragraph 3.17.2.1. immediately before testing.
- 3.17.3. Test procedure
- 3.17.3.1. Mount the assembly on a test axle and press it against the outer face of a smooth wheel having a diameter of $1.70 \text{ m} \pm 1$ per cent.
- 3.17.3.2. During the test, the ambient temperature, at a distance of not less than 150 mm and not more than 1 m from the tyre, is maintained at 35 ± 3 °C.
- 3.17.3.3. Conduct the test, without interruptions, at the test speed of not less than 120 km/h with loads and test periods not less than those shown in the following table. For snow tyres for use in severe snow conditions and marked with the three-peaked mountain-snowflake symbol, conduct the test at not less than 110 km/h.

<i>Test period</i>	<i>Duration (hours)</i>	<i>Load as a percentage of tyre maximum load rating</i>
1	4	85
2	6	90
3	24	100

3.17.3.4. Throughout the test, the inflation pressure is not corrected and the test loads are maintained at the value corresponding to each test period, as shown in the table in paragraph 3.17.3.3.

- 3.17.3.5. Allow the tyre to cool for between 15 minutes and 25 minutes after running the tyre for the time specified in the table in paragraph 3.17.3.3., measure its inflation pressure. Inspect the tyre externally on the test rim for the conditions specified in paragraph 3.17.1.1.
- 3.18. Low inflation pressure performance test for LT/C tyres¹⁷
- 3.18.1. Requirements
- 3.18.1.1. When the tyre is tested in accordance with paragraph 3.18.3:
- There shall be no visual evidence of tread, sidewall, ply, cord, inner liner, belt or bead separation, chunking, open splices, cracking, or broken cords, and
 - The tyre pressure, when measured at any time between 15 minutes and 25 minutes after the end of the test, shall not be less than 95 per cent of the initial pressure specified in paragraph 3.18.2.1.
- 3.18.2. Preparation of tyre
- 3.18.2.1. This test is conducted following completion of the tyre endurance test using the same tyre and rim assembly tested in accordance with paragraph 3.17. with the tyre deflated to the following appropriate pressure:

<i>Light truck tyres with a nominal section width ≤ 295 mm (11.5 inches)</i>	
<i>Tyre application</i>	<i>Test pressure (kPa)</i>
Load range C	200
Load range D	260
Load range E	320
<i>Light truck tyres with a nominal section width > 295 mm (11.5 inches)</i>	
Load range C	150
Load range D	200
Load range E	260

- 3.18.2.2. After the tyre is deflated to the appropriate test pressure in paragraph 3.18.2.1. at the completion of the endurance test, condition the assembly at 35 ± 3 °C for not less than 2 hours.
- 3.18.2.3. Before or after mounting the assembly on a test axle, readjust the tyre pressure to that specified in paragraph 3.18.2.1.
- 3.18.3. Test procedure
- 3.18.3.1. The test is conducted for ninety minutes at the end of the test specified in paragraph 3.17., continuous and uninterrupted, at a speed of 120 km/h. For snow tyres for use in severe snow conditions and marked with the three-peaked mountain-snowflake symbol, conduct the test at not less than 110 km/h.

¹⁷ From FMVSS 139

- 3.18.3.2. Press the assembly against the outer face of a test drum with a diameter of 1.70 m \pm 1 per cent.
- 3.18.3.3. Apply to the test axle a load equal to 100 per cent of the tyre's maximum load carrying capacity.
- 3.18.3.4. Throughout the test, the inflation pressure is not corrected and the test load is maintained at the initial level.
- 3.18.3.5. During the test, the ambient temperature, at a distance of not less than 150 mm and not more than 1 m from the tyre, is maintained at 35 \pm 3 °C.
- 3.18.3.6. Allow the tyre to cool for between 15 minutes and 25 minutes. Measure its inflation pressure. Then, deflate the tyre, remove it from the test rim, and inspect it for the conditions specified in paragraph 3.18.1.1., subparagraph (a).
- 3.19. High speed performance test for LT/C tyres¹⁸
- 3.19.1. Requirements
- 3.19.1.1. When the tyre is tested in accordance with paragraph 3.19.3.:
 - (a) There shall be no visual evidence of tread, sidewall, ply, cord, inner liner, belt or bead separation, chunking, open splices, cracking, or broken cords.
 - (b) The tyre pressure, when measured at any time between 15 minutes and 25 minutes after the end of the test, shall not be less than 95 per cent of the initial pressure specified in paragraph 3.19.2.1.
- 3.19.2. Preparation of tyre
- 3.19.2.1. Mount the tyre on a test rim and inflate it to the pressure specified for the tyre in the following table:

<i>Light truck tyres with a nominal section width \leq 295 mm (11.5 inches)</i>	
<i>Tyre application</i>	<i>Test pressure (kPa)</i>
Load range C	320
Load range D	410
Load range E	500
<i>Light truck tyres with a nominal section width $>$ 295 mm (11.5 inches)</i>	
Load range C	230
Load range D	320
Load range E	410

- 3.19.2.2. Condition the assembly at 35 \pm 3 °C for not less than 3 hours.
- 3.19.2.3. Before or after mounting the assembly on a test axle, readjust the tyre pressure to that specified in paragraph 3.19.2.1.

¹⁸ From FMVSS 139

- 3.19.3. Test procedure
- 3.19.3.1. Press the assembly against the outer face of a test drum with a diameter of 1.70 m \pm 1 per cent.
- 3.19.3.2. Apply to the test axle a load equal to 85 per cent of the tyre's maximum load carrying capacity.
- 3.19.3.3. Break-in the tyre by running it for 2 hours at 80 km/h.
- 3.19.3.4. Allow tyre to cool to 38 °C and readjust inflation pressure to applicable pressure in paragraph 3.19.2.1. immediately before the test.
- 3.19.3.5. Throughout the test, the inflation pressure is not corrected and the test load is maintained at the value applied in paragraph 3.19.2.1.
- 3.19.3.6. During the test, the ambient temperature, measured at a distance of not less than 150 mm and not more than 1 m from the tyre, is maintained at 35 \pm 3 °C.
- 3.19.3.7. The test is conducted, continuously and uninterrupted, for ninety minutes through three thirty-minute consecutive test stages at the following speeds: 140, 150, and 160 km/h.
- 3.19.3.8. Allow the tyre to cool for between 15 minutes and 25 minutes. Measure its inflation pressure. Then, deflate the tyre, remove it from the test rim, and inspect it for the conditions specified in paragraph 3.19.1.1., subparagraph (a).
- 3.20. Physical dimensions of LT/C tyres¹⁹
- 3.20.1. Requirements
- 3.20.1.1. The actual section width and overall width for each tyre measured in accordance with paragraph 3.20.3. shall not exceed the section width specified one of the publications described in Annex ~~740~~ to this Regulation for its size designation and type by more than:
- (a) For tyres with a maximum permissible inflation pressure of 32, 36, or 40 psi, 7 per cent, or
- (b) For tyres with a maximum permissible inflation pressure of 240, 280, 300, 340 or 350 kPa, 7 per cent or 10 mm, whichever is larger.
- 3.20.2. Preparation of the tyre
- 3.20.2.1. Mount the tyre on the measuring rim specified by the tyre manufacturer or in one of the publications listed in Annex ~~740~~ to this Regulation.
- 3.20.2.2. Inflate the tyre to the pressure at maximum load as labelled on sidewall.
- 3.20.2.3. Condition the assembly at an ambient room temperature of 20 °C to 30 °C for not less than 24 hours.
- 3.20.2.4. Readjust the tyre pressure to that specified in paragraph 3.20.2.2.
- 3.20.3. Test procedure
- 3.20.3.1. Measure the section width and overall width by caliper at six points approximately equally spaced around the circumference of the tyre, avoiding measurement of the additional thickness of the special protective ribs or

¹⁹ From FMVSS 139.

bands. The average of the measurements so obtained is taken as the section width and overall width, respectively.

3.20.3.2. Determine the outer diameter by measuring the maximum circumference of the tyre and dividing the figure so obtained by Pi (3.1416).

3.21. Physical dimensions of LT/C tyres²⁰

3.21.1. Requirements

3.21.1.1. Section width of a tyre

3.21.1.1.1. The section width shall be obtained by means of the following formula:

$$S = S_1 + K (A - A_1),$$

Where:

S is the "section width" expressed in millimetres and measured on the measuring rim;

S₁ is "the nominal section width" in millimetres, as shown on the sidewall of the tyre in the tyre designation as prescribed;

A is the width of the measuring rim in millimetres, as shown by the manufacturer in the descriptive note; and

A₁ is the width of the theoretical rim in millimetres.

A₁ shall be taken to equal S₁ multiplied by the factor x as specified by the manufacturer, and K shall be taken to equal 0.4.

3.21.1.1.2. However, for the existing types of tyres whose designation is given in the first column of the tables in Annex 67 to this regulation, the section width shall be deemed to be that given opposite the tyre designation in those tables.

3.21.1.2. Outer diameter of a tyre

3.21.1.2.1. The outer diameter of a tyre shall be obtained by means of the following formula:

$$D = d + 2H$$

Where:

D is the outer diameter expressed in millimetres;

d is the rim diameter, expressed in millimetres as shown in Annex 3;

H is the nominal section height in millimetres and is equal to S₁ x 0.01 Ra:

S₁ is the nominal section width in millimetres;

Ra is the nominal aspect ratio.

All as in the tyre designation shown on the sidewall of the tyre.

3.21.1.2.2. However, for the existing types of tyres whose designation is given in the first column of the tables in Annex 67 to this regulation, the outer diameter shall be deemed to be that given opposite the tyre designation in those tables.

²⁰ From Regulation No. 54

- 3.21.1.3. Tyre section width specifications
- 3.21.1.3.1. The overall width of a tyre may be less than the section width or widths determined pursuant to paragraph 3.21.1.1. above.
- 3.21.1.3.2. It may exceed that value by 4 per cent. However, for tyres with nominal section width exceeding 305 mm intended for dual mounting (twinning), the value determined pursuant to paragraph 3.21.1.1. above shall not be exceeded by more than 2 per cent for tyres with nominal aspect ratio higher than 60.
- 3.21.1.4. Tyre outer diameter specifications
- 3.21.1.4.1. The outer diameter of a tyre shall not be outside the values D_{min} and D_{max} obtained from the following formulae:
- $$D_{min} = d + (2H \times a)$$
- $$D_{max} = d + (2H \times b)$$
- 3.21.1.4.2. For sizes listed in Annex 67 to this regulation the nominal section height H is equal to:
- $$H = 0.5 (D-d) \text{ for references see paragraph 3.21.1.2.1.}$$
- 3.21.1.4.2.1. For other sizes, not listed in Annex 67 to this regulation
"H" and "d" are as defined in paragraph 3.21.1.2.1
- 3.21.1.4.2.2. Coefficients "a" and "b" are respectively:
- 3.21.1.4.2.2.1. Coefficient "a" = 0.97
- 3.21.1.4.2.2.2. Coefficient "b"
- For normal use tyres = 1.04
- For special use tyres = 1.06
- 3.21.1.4.2.2.3. For snow tyres the outer diameter (D_{max}) established in conformity with the above may be exceeded by 1 per cent.
- 3.21.2. Test procedure
- 3.21.2.1. The tyre is mounted on the measuring rim specified by the manufacturer and inflated to the pressure corresponding to the pressure index specified by the manufacturer.
- 3.21.2.2. The tyre fitted on its rim is conditioned to the ambient temperature of the laboratory for at least 24 hours.
- 3.21.2.3. The pressure is readjusted to the value specified in paragraph 3.21.2.1. above.
- 3.21.2.4. The overall width is measured by caliper at six equally spaced points, account being taken of the thickness of the protective ribs or bands. The highest measurement so obtained is taken as the overall width.
- 3.21.2.5. The outer diameter is calculated from the maximum circumference.

3.22. Tyre rolling resistance test

3.22.1. Requirements

The following requirements does not apply to professional off-road tyres, tyres fitted with additional devices to improve traction properties (e.g. studded tyres), tyres with a speed rating less than 80 km/h (speed

Comment [JN64]: 02 series of amendments - Date of entry into force: 30 January 2011

symbol F) and those having a nominal rim diameter code ≤ 10 (or ≤ 254 mm) or ≥ 25 (or ≥ 635 mm).

3.22.1.1. The maximum values ~~for stage 1~~ for the rolling resistance coefficient shall not exceed the following (value in N/kN is equivalent to value in kg/tonne):

<i>Tyre class</i>	<i>Max value (N/kN)</i>
C1	[12.0]
C2	[10.5]
C3	[8.0]
For "snow tyre for use in severe snow conditions", the limits shall be increased by 1 N/kN.	

~~3.22.1.2. The maximum values for stage 2 for the rolling resistance coefficient shall not exceed the following (value in N/kN is equivalent to value in kg/tonne):~~

~~f~~

<i>Tyre class</i>	<i>Max value (N/kN)</i>
C1	[10.5]
C2	[9.0]
C3	[6.5]
For "snow tyre for use in severe snow conditions", the limits shall be increased by 1 N/kN.	

3.22.2. Test Methods

The alternative measurement methods listed below are given in this Regulation. The choice of an individual method is left to the tester. For each method, the test measurements shall be converted to a force acting at the tyre/drum interface. The measured parameters are:

- a) In the force method: the reaction force measured or converted at the tyre spindle²¹;
- b) In the torque method: the torque input measured at the test drum²²;
- c) In the deceleration method: the measurement of deceleration of the test drum and tyre assembly¹⁹;
- d) In the power method: the measurement of the power input to the test drum¹⁹.

²¹ This measured value also includes the bearing and aerodynamic losses of the wheel and tyre which are also to be considered for further data interpretation.

²² The measured value in the torque, deceleration and power methods also includes the bearing and aerodynamic losses of the wheel, the tyre, and the drum which are also to be considered for further data interpretation.

Comment [JN65]: Exemption from UN Reg. 117.02

Comment [JN66]: Agreement during GRRF 80th session to keep the most stringent requirements.

3.22.3. Test Equipment**3.22.3.1. Drum specifications****3.22.3.1.1. Diameter**

The test dynamometer shall have a cylindrical flywheel (drum) with a diameter of at least 1.7 m.

The F_r and C_r values shall be expressed relative to a drum diameter of 2.0 m. If drum diameter different than 2.0 m is used, a correlation adjustment shall be made following the method in paragraph 3.22.7.3.

3.22.3.1.2. Surface

The surface of the drum shall be smooth steel. Alternatively, in order to improve skim test reading accuracy, a textured surface may also be used, which should be kept clean.

The F_r and C_r values shall be expressed relative to the "smooth" drum surface. If a textured drum surface is used, see Annex 8, paragraph 7.

3.22.3.1.3. Width

The width of the drum test surface shall exceed the width of the test tyre contact patch.

3.22.3.2. Measuring rim (see Annex 9)

The tyre shall be mounted on a steel or light alloy measuring rim, as follows:

(a) For Class C1 tyres, the width of the rim shall be as defined in ISO 4000-1:2010,

(b) For Class C2 and C3 tyres, the width of the rim shall be as defined in ISO 4209 1:2001.

In cases where the width is not defined in the above mentioned ISO Standards, the rim width as defined by one of the standards organizations as specified in Annex 7 may be used."

3.22.3.3. Load, alignment, control and instrumentation accuracies

Measurement of these parameters shall be sufficiently accurate and precise to provide the required test data. The specific and respective values are shown in Annex 8.

3.22.3.4. Thermal environment**3.22.3.4.1. Reference conditions**

The reference ambient temperature, measured at a distance not less than 0.15 m and not more than 1 m from the tyre sidewall, shall be 25 °C.

3.22.3.4.2. Alternative conditions

If the test ambient temperature is different from the reference ambient temperature, the rolling resistance measurement shall be corrected to the reference ambient temperature in accordance with paragraph 3.22.7.2. of this annex.

3.22.3.4.3. Drum surface temperature.

Comment [AR67]: Revision 2 - Amendment 2
Supplement 2 to the 02 series of amendments – Date of entry into force: 15 July 2013
WP.29/2012/55

Care should be taken to ensure that the temperature of the test drum surface is the same as the ambient temperature at the beginning of the test.

3.22.4. Test Conditions

3.22.4.1. General

The test consists of a measurement of rolling resistance in which the tyre is inflated and the inflation pressure allowed to build up, i.e., "capped air".

3.22.4.2. Test speeds

The value shall be obtained at the appropriate drum speed specified in Table 1.

Table 1
Test Speeds (in km/h)

Tyre Class	C1	C2 and C3	C3	
Load Index	All	LI ≤ 121	LI > 121	
Speed Symbol	All	All	J 100 km/h and lower or tyres not marked with speed symbol	K 110 km/h and higher
Speed	80	80	60	80

3.22.4.3. Test load

The standard test load shall be computed from the values shown in Table 2 and shall be kept within the tolerance specified in Annex 8.

3.22.4.4. Test inflation pressure

The inflation pressure shall be in accordance with that shown in Table 2 and shall be capped with the accuracy specified in paragraph 4. of Annex 8.

Table 2
Test Loads and Inflation Pressures

Tyre Class	C1 ^(a)		C2, C3
	Standard Load	Extra Load	
Load- % of maximum load capacity	80	80	85 ^(b) (% of single load)
Inflation pressure kPa	210	250	Corresponding to maximum load capacity for single application ^(c)
<i>Note:</i> The inflation pressure shall be capped with the accuracy specified in paragraph 4 of Annex 8.			

Tyre Class	C1 ^(a)	C2, C3
<p>(a) For those passenger car tyres belonging to categories which are not shown in ISO 4000-1:2010, the inflation pressure shall be the inflation pressure recommended by the tyre manufacturer, corresponding to the maximum tyre load capacity, reduced by 30 kPa.</p> <p>(b) As a percentage of single load, or 85 per cent of maximum load capacity for single application specified in applicable tyre standards manuals if not marked on tyre.</p> <p>(c) Inflation pressure marked on sidewall, or if not marked on sidewall, as specified in applicable tyre standards manuals corresponding to maximum load capacity for single application.</p>		

3.22.4.5. Duration and speed.

When the deceleration method is selected, the following requirements apply:

- (a) The deceleration j shall be determined in differential $d\omega/dt$ or discrete $\Delta\omega/\Delta t$ form, where ω is angular velocity, t – time;
If the differential form $d\omega/dt$ is used, then the recommendations of Annex 10 are to be applied.
- (b) For duration Δt , the time increments shall not exceed 0.5 s;
- (c) Any variation of the test drum speed shall not exceed 1 km/h within one time increment.

Comment [AR68]: Proposal for Supplement 7 to the 02 series of amendments to Regulation No. 117 WP.29/2015/5

Comment [AR69]: Revision 2 – Amendment 1
Supplement 1 to the 02 series of amendments - Date of entry into force: 18 November 2012
WP.29/2012/6

3.22.5. Test Procedure

3.22.5.1. General

The test procedure steps described below shall be followed in the sequence given.

3.22.5.2. Thermal conditioning

The inflated tyre shall be placed in the thermal environment of the test location for a minimum of:

- (a) 3 hours for Class C1 tyres;
- (b) 6 hours for Class C2 and C3 tyres.

3.22.5.3. Pressure adjustment

After thermal conditioning, the inflation pressure shall be adjusted to the test pressure, and verified 10 minutes after the adjustment is made.

3.22.5.4. Warm-up

The warm-up durations shall be as specified in Table 3

Table 3
Warm Up Durations

Tyre Class	C1	C2 and C3	
		LI ≤ 121	LI > 121
Nominal Rim Diameter	All	All	< 22.5 ≥ 22.5

Tyre Class	C2 and C3		C3	
	CI	LI ≤ 121	LI > 121	LI > 121
Warm up duration	30 min.	50 min.	150 min.	180 min.

3.22.5.5. Measurement and recording

The following shall be measured and recorded (see Figure 1):

- (a) Test speed U_n ;
- (b) Load on the tyre normal to the drum surface L_m ;
- (c) The initial test inflation pressure as defined in paragraph 3.22.4.3.;
- (d) The coefficient of rolling resistance measured C_r , and its corrected value $C_{r,c}$, at 25 °C and for a drum diameter of 2 m;
- (e) The distance from the tyre axis to the drum outer surface under steady state r_L ;
- (f) Ambient temperature t_{amb} ;
- (g) Test drum radius R ;
- (h) Test method chosen;
- (i) Test rim (size and material);
- (j) Tyre size, manufacturer, type, identity number (if one exists), speed symbol, load index, DOT number (Department of Transportation).

Figure 1

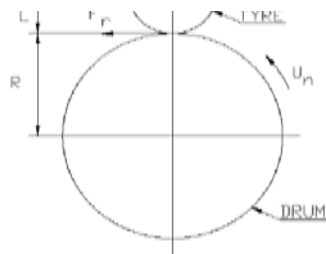

FIGURE 1

All the mechanical quantities (forces, torques) will be orientated in accordance with the axis systems specified in ISO 8855:1991.

The directional tyres shall be run in their specified rotation sense.

3.22.5.6. Measurement of parasitic losses

The parasitic losses shall be determined by one of the following procedures given in paragraph 3.22.5.6.1. or 3.22.5.6.2.

3.22.5.6.1. Skim test reading

Skim test reading follows the procedure below:

- (a) Reduce the load to maintain the tyre at the test speed without slippage²³.

The load values should be as follows:

- (i) Class C1 tyres: recommended value of 100 N; not to exceed 200 N;
- (ii) Class C2 tyres: recommended value of 150 N; not to exceed 200 N for machines designed for Class C1 tyre measurement or 500 N for machine designed for Class C2 and C3 tyres;
- (iii) Class C3 tyres: recommended value of 400 N; not to exceed 500 N.

- (b) Record the spindle force F_s , input torque T_i , or the power, whichever applies²⁰;

- (c) Record the load on the tyre normal to the drum surface L_m ²⁰.

3.22.5.6.2. Deceleration method

The deceleration method follows the procedure below:

- (a) Remove the tyre from the test surface;
- (b) Record the deceleration of the test drum $\Delta\omega_{D0}/\Delta t$ and that of the unloaded tyre $\Delta\omega_{T0}/\Delta t$ ²⁰ or record the deceleration of the test drum j_{D0} and that of the unloaded tyre j_{T0} in exact or approximate form in accordance with paragraph 3.22.4.5.

3.22.5.7. Allowance for machines exceeding σ_m criterion

The steps described in paragraphs 3.22.5.3. to 3.22.5.5. shall be carried out once only, if the measurement standard deviation determined in accordance with paragraph 6.5. is:

- (a) Not greater than 0.075 N/kN for Class C1 and C2 tyres;
- (b) Not greater than 0.06 N/kN for Class C3 tyres.

If the measurement standard deviation exceeds this criterion, the measurement process will be repeated n times as described in paragraph 3.22.7.5. The rolling resistance value reported shall be the average of the n measurements.

3.22.6. Data Interpretation

3.22.6.1. Determination of parasitic losses

3.22.6.1.1. General

Comment [AR70]: Revision 2 – Amendment 1
Supplement 1 to the 02 series of amendments - Date of entry into force: 18 November 2012
WP.29/2012/6

²³ With the exception of the force method, the measured value includes the bearing and aerodynamic losses of the wheel, the tyre, and the drum losses which also need to be considered. It is known that the spindle and drum bearing frictions depend on the applied load. Consequently, it is different for the loaded system measurement and the skim test reading. However, for practical reasons, this difference can be disregarded.

The laboratory shall perform the measurements described in paragraph 3.22.5.6.1. for the force, torque and power methods or those described in paragraph 3.22.5.6.2. for the deceleration method, in order to determine precisely in the test conditions (load, speed, temperature) the tyre spindle friction, the tyre and wheel aerodynamic losses, the drum (and as appropriate, engine and/or clutch) bearing friction, and the drum aerodynamic losses.

The parasitic losses related to the tyre/drum interface F_{pl} expressed in newton shall be calculated from the force F_t torque, power or the deceleration, as shown in paragraphs 3.22.6.1.2. to 3.22.6.1.5. below.

3.22.6.1.2. Force method at tyre spindle

Calculate: $F_{pl} = F_t (1 + r_L/R)$

Where:

F_t is the tyre spindle force in newton (see paragraph 3.22.5.6.1.),

r_L is the distance from the tyre axis to the drum outer surface under steady state conditions, in metre,

R is the test drum radius, in meter.

3.22.6.1.3. Torque method at drum axis

Calculate: $F_{pl} = T_t/R$

Where:

T_t is the input torque in newton meter, as determined in paragraph 3.22.5.6.1,

R is the test drum radius, in meter.

3.22.6.1.4. Power method at drum axis

Calculate:

$$F_{pl} = \frac{3,6 V x A}{U}$$

Where:

V is the electrical potential applied to the machine drive, in volt,

A is the electric current drawn by the machine drive, in ampere,

U_n is the test drum speed, in kilometre per hour.

3.22.6.1.5. Deceleration method

Calculate the parasitic losses F_{pl} , in newton.

Comment [AR72]: Revision 2 – Amendment 1
Supplement 1 to the 02 series of amendments - Date of entry into force: 18 November 2012
WP.29/2012/6

$$F_{pl} = \frac{I_D}{R} \left(\frac{\Delta\omega_{D0}}{\Delta t_0} \right) + \frac{I_T}{R_r} \left(\frac{\Delta\omega_{T0}}{\Delta t_0} \right)$$

Where:

- I_D** is the test drum inertia in rotation, in kilogram meter squared,
- R** is the test drum surface radius, in meter,
- ω_{D0}** is the test drum angular speed, without tyre, in radians per second,
- Δt_0** is the time increment chosen for the measurement of the parasitic losses without tyre, in second,
- I_T** is the spindle, tyre and wheel inertia in rotation, in kilogram meter squared,
- R_r** is the tyre rolling radius, in metre,
- ω_{T0}** is the tyre angular speed, unloaded tyre, in radian per second.
- or

$$F_{pl} = \frac{I_D}{R} j_{D0} + \frac{I_T}{R_r} j_{T0}$$

Where:

- I_D** is the test drum inertia in rotation, in kilogram meter squared,
- R** is the test drum surface radius, in meter,
- j_{D0}** is the deceleration of the test drum, without tyre, in radians per second squared,
- I_T** is the spindle, tyre and wheel inertia in rotation, in kilogram meter squared,
- R_r** is the tyre rolling radius, in metre,
- j_{T0}** is the deceleration of unloaded tyre, in radians per second squared."

3.22.6.2. Rolling resistance calculation

3.22.6.2.1. General

The rolling resistance F_r , expressed in newton, is calculated using the values obtained by testing the tyre to the conditions specified in this international standard section 3.7.3.1 and by subtracting the appropriate parasitic losses F_{pl} , obtained according to paragraph 3.22.6.1.

3.22.6.2.2. Force method at tyre spindle

The rolling resistance F_r , in newton, is calculated using the equation

$$F_r = F_t[1 + (r_t/R)] - F_{pl}$$

Comment [AR71]: Proposal for Supplement 7 to the 02 series of amendments to Regulation No. 117 WP.29/2015/5

Comment [JN73]: Editorial correction

Where:

- F_t is the tyre spindle force in newton,
- F_{pl} represents the parasitic losses as calculated in paragraph 3.22.6.1.2.,
- r_L is the distance from the tyre axis to the drum outer surface under steady-state conditions, in metre,
- R is the test drum radius, in metre.

3.22.6.2.3. Torque method at drum axis

The rolling resistance F_r , in newton, is calculated with the equation

$$F_r = \frac{T_t}{R} - F_{pl}$$

Where:

- T_t is the input torque, in newton metre,
- F_{pl} represents the parasitic losses as calculated in paragraph 3.22.6.1.3.,
- R is the test drum radius, in metre.

3.22.6.2.4. Power method at drum axis

The rolling resistance F_r , in newton, is calculated with the equation:

$$F_r = \frac{3.6V \times A}{U_n} - F_{pl}$$

Where:

- V = is the electrical potential applied to the machine drive, in volt,
- A = is the electric current drawn by the machine drive, in ampere,
- U_n = is the test drum speed, in kilometre per hour,
- F_{pl} = represents the parasitic losses as calculated in paragraph 3.22.6.1.4.

3.22.6.2.5. Deceleration method

The rolling resistance F_r , in newton, is calculated using the

equation:
$$F_r = \frac{I_D}{R} \left(\frac{\Delta\omega_V}{\Delta t_V} \right) + \frac{RI_T}{R_r^2} \left(\frac{\Delta\omega_V}{\Delta t_V} \right) - F_{pl}$$

Where:

- I_D is the test drum inertia in rotation, in kilogram metre squared,
- R is the test drum surface radius, in meter,

Comment [AR74]: Revision 2 – Amendment 1
 Supplement 1 to the 02 series of amendments - Date of entry into force: 18 November 2012
 WP.29/2012/6

F_{pl}	represents the parasitic losses as calculated in paragraph 3.22.6.1.5.,
Δt_v	is the time increment chosen for measurement, in second,
$\Delta \omega_v$	is the test drum angular speed increment, without tyre, in radian per second,
I_T	is the spindle, tyre and wheel inertia in rotation, in kilogram metre squared,
R_r	is the tyre rolling radius, in metre,
F_r	is the rolling resistance, in newton.

or

$$F_r = \frac{I_D}{R} j_v + \frac{R I_T}{R_r^2} j_v - F_{pl}$$

Where:

I_D	is the test drum inertia in rotation, in kilogram metre squared,
R	is the test drum surface radius, in meter,
F_{pl}	represents the parasitic losses as calculated in paragraph 3.22.6.1.5.,
j_v	is the deceleration of the test drum, in radians per second squared,
I_T	is the spindle, tyre and wheel inertia in rotation, in kilogram metre squared,
R_r	is the tyre rolling radius, in metre,
F_r	is the rolling resistance, in newton."

3.22.7. Data Analysis

3.22.7.1. Rolling resistance coefficient

The rolling resistance coefficient C_r is calculated by dividing the rolling resistance by the load on the tyre:

$$C_r = \frac{F_r}{L_m}$$

Where:

F_r	is the rolling resistance, in newton,
L_m	is the test load, in kN.

3.22.7.2. Temperature correction

If measurements at temperatures other than 25 °C are unavoidable (only temperatures not less than 20 °C or more than 30 °C are acceptable),

Comment [AR75]: Revision 2 - Amendment 3
Supplement 3 to the 02 series of amendments – Date of entry into force: 3 November 2013
WP.29/2013/7

then a correction for temperature shall be made using the following equation, with:

F_{r25} is the rolling resistance at 25 °C, in Newton:

$$F_{r25} = F_r [1 + K(t_{amb} - 25)]$$

Where:

F_r is the rolling resistance, in Newton,

t_{amb} is the ambient temperature, in degree Celsius,

K is equal to:

0.008 for Class C1 tyres

0.010 for Class C2 and C3 tyres with a load index equal or lower than 121

0.006 for Class C3 tyres with a load index greater than 121"

3.22.7.3. Drum diameter correction

Test results obtained from different drum diameters shall be compared by using the following theoretical formula:

$$F_{r02} \cong KF_{r01}$$

with:

$$K = \sqrt{\frac{(R_1/R_2)(R_2 + r_T)}{(R_1 + r_T)}}$$

Where:

R_1 is the radius of drum 1, in meter,

R_2 is the radius of drum 2, in meter,

r_T is one-half of the nominal design tyre diameter, in meter,

F_{r01} is the rolling resistance value measured on drum 1, in newton,

F_{r02} is the rolling resistance value measured on drum 2, in newton.

3.22.7.4. Measurement result

Where n measurements are greater than 1, if required by paragraph 3.22.5.6., the measurement result shall be the average of the C_r values obtained for the n measurements, after the corrections described in paragraphs 3.22.7.2. and 3.22.7.3. have been made.

3.22.7.5. The laboratory shall ensure that, based on a minimum of three measurements, the machine maintains the following values of σ_m , as measured on a single tyre:

$\sigma_m \leq 0.075$ N/kN for tyres of Classes C1 and C2

$\sigma_m \leq 0.06$ N/kN for tyres of Class C3

If the above requirement for σ_m is not met, the following formula shall be applied to determine the minimum number of measurements n (rounded to the immediate superior integer value) that are required by the machine to qualify for conformance with this Regulation.

$$n = (\sigma_m / x)^2$$

Where:

$x = 0.075$ N/kN for tyres of Classes C1 and C2

$x = 0.06$ N/kN for tyres of Class C3

If a tyre needs to be measured several times, the tyre/wheel assembly shall be removed from the machine between the successive measurements.

If the removal/refitting operation duration is less than 10 minutes, the warm-up durations indicated in paragraph 3.22.5.3. may be reduced to:

- (a) 10 minutes for tyres of Class C1;
- (b) 20 minutes for tyres of Class C2;
- (c) 30 minutes for tyres of Class C3.

3.22.7.6. Monitoring of the laboratory control tyre shall be carried out at intervals no greater than one month. Monitoring shall include a minimum of 3 separate measurements taken during this one month period. The average of the 3 measurements taken during a given one-month period shall be evaluated for drift from one monthly evaluation to another.

3.23. **Snow performance** test relative to snow tyre for use in severe snow conditions

In order to be classified as a "snow tyre for use in severe snow conditions" the tyre shall meet the performance requirements of paragraph 3.23.1. The tyre shall meet these requirements based on a test method by which:

- (a) the mean fully developed deceleration ("mfdd") in a braking test,
- (b) or alternatively an average traction force in a traction test,
- (c) or alternatively the average acceleration in an acceleration test

of the candidate tyre is compared to that of a standard reference tyre.

The relative performance shall be indicated by a snow index.

3.23.1 Tyre snow performance requirements

The following requirements does not apply to professional off-road tyres, tyres fitted with additional devices to improve traction properties (e.g. studded tyres), tyres with a speed rating less than 80 km/h (speed symbol F) and those having a nominal rim diameter code ≤ 10 (or ≤ 254 mm) or ≥ 25 (or ≥ 635 mm).

3.23.1.1. Class C1, C2 and C3 tyres

Comment [JN76]: Revision 2 – Amendment 1
Supplement 1 to the 02 series of amendments - Date of entry into force: 18 November 2012
WP.29/2012/2 amended by para 65 of ECE/TRANS/WP.29/1095
and
Revision 2 - Amendment 2
Supplement 2 to the 02 series of amendments – Date of entry into force: 15 July 2013
WP.29/2012/54

Comment [JN77]: Exemption from UN Reg. 117.02

The minimum snow index value, as calculated in the procedure described in this paragraph for the different class of tyres, shall be as follows:

Class of tyre	Snow grip index (brake on snow method) ^(a)		Snow grip index (spin traction method) ^(b)	Snow grip index (acceleration method) ^(c)
	Ref. = C1 – SRTT 14	Ref. = C2 – SRTT 16C	Ref. = C1 – SRTT 14	Ref. = C3N – SRTT 19.5 Ref. = C3W – SRTT 22.5
C1	1.07	No	1.10	No
C2	No	1.02	1.10	No
C3	No	No	No	1.25

^(a) See paragraph 3.23.3.

^(b) See paragraph 3.23.2.

^(c) See paragraph 3.23.4.

3.23.2. Spin traction method for Classes C1 and C2 tyres (traction force test).

The test procedure of ASTM standard F1805-06 shall be used to assess snow performance through spin traction values on medium packed snow (The snow compaction index measured with a CTI penetrometer²⁴ shall be between 70 and 80).

3.23.2.1. The test course surface shall be composed of a medium packed snow surface, as characterized in table A2.1 of ASTM standard F1805-06.

3.23.2.2. The tyre load for testing shall be as per option 2 in paragraph 11.9.2. of ASTM standard F1805-06.

3.23.3. Braking on snow method for Classes C1 and C2 tyres

3.23.3.1. General conditions

3.23.3.1.1. Test course

The braking tests shall be done on a flat test surface of sufficient length and width, with a maximum 2 per cent gradient, covered with packed snow.

The snow surface shall be composed of a hard packed snow base at least 3 cm thick and a surface layer of medium packed and prepared snow about 2 cm thick.

The air temperature, measured about one meter above the ground, shall be between -2 °C and -15 °C; the snow temperature, measured at a depth of about one centimetre, shall be between -4 °C and -15 °C.

It is recommended to avoid direct sunlight, large variations of sunlight or humidity, as well as wind.

The snow compaction index measured with a CTI penetrometer²¹ shall be between 75 and 85.

Comment [AR78]: Revision 2 - Amendment 2
Supplement 2 to the 02 series of amendments – Date of entry into force: 15 July 2013
WP.29/2012/54

Comment [AR79]: Revision 2 - Amendment 2
Supplement 2 to the 02 series of amendments – Date of entry into force: 15 July 2013
WP.29/2012/54

Comment [AR80]: Revision 3 - Corrigendum 1
Corrigendum 4 to 02 series of amendments – Date of entry into force: 12 March 2014 (4C to -4C)

Comment [AR81]: Revision 2 - Amendment 2
Supplement 2 to the 02 series of amendments – Date of entry into force: 15 July 2013
WP.29/2012/54

²⁴ See appendix of ASTM standard F1805-06 for details.

3.23.3.1.2. Vehicle

The test shall be conducted with a standard production vehicle in good running order and equipped with an ABS system.

The vehicle used shall be such that the loads on each wheel are appropriate to the tyres being tested. Several different tyre sizes can be tested on the same vehicle."

3.23.3.1.3. Tyres

The tyres should be "broken-in" prior to testing to remove spew, compound nodules or flashes resulting from the moulding process. The tyre surface in contact with snow shall be cleaned before performing a test.

Tyres shall be conditioned at the outdoor ambient temperature at least two hours before their mounting for tests. Tyre pressures shall then be adjusted to the values specified for the test.

In case a vehicle cannot accommodate both the reference and candidate tyres, a third tyre ("control" tyre) may be used as an intermediate. First test control vs. reference on another vehicle, then test candidate vs. control on the vehicle.

3.23.3.1.4. Load and pressure:

3.23.3.1.4.1. For C1 tyres, the vehicle load shall be such that the resulting loads on the tyres are between 60 per cent and 90 per cent of the load corresponding to the tyre load index.

The cold inflation pressure shall be 240 kPa.

3.23.3.1.4.2. For C2 tyres, the vehicle load shall be such that the resulting loads on the tyres are between 60 per cent and 100 per cent of the load corresponding to the tyre load index.

The static tyre load on the same axle should not differ by more than 10 per cent.

The inflation pressure is calculated to run at constant deflection:

For a vertical load higher or equal to 75 per cent of the load capacity of the tyre, a constant deflection is applied, hence the test inflation pressure "Pt" shall be calculated as follows:

$$P_t = P_r \left(\frac{Q_t}{Q_r} \right)^{1.25}$$

Qr is the maximum load associated to the load capacity index of the tyre written on the sidewall

Pr is the reference pressure corresponding to the maximum load capacity Qr

Qt is the static test load of the tyre

For a vertical load lower than 75 per cent of the load capacity of the tyre, a constant inflation pressure is applied, hence the test inflation pressure Pt shall be calculated as follows:

Comment [AR82]: Revision 2 - Amendment 2
Supplement 2 to the 02 series of amendments – Date of entry into force: 15 July 2013
WP.29/2012/54

Comment [AR83]: Revision 2 – Amendment 1
Supplement 1 to the 02 series of amendments - Date of entry into force: 18 November 2012
WP.29/2012/2

Comment [AR84]: Revision 2 - Amendment 2
Supplement 2 to the 02 series of amendments – Date of entry into force: 15 July 2013
WP.29/2012/54

Comment [AR85]: Revision 2 – Amendment 1
Supplement 1 to the 02 series of amendments - Date of entry into force: 18 November 2012
WP.29/2012/2

Comment [AR86]: Revision 2 - Amendment 2
Supplement 2 to the 02 series of amendments – Date of entry into force: 15 July 2013
WP.29/2012/54

Comment [AR87]: Proposal for Supplement 7 to the 02 series of amendments to Regulation No. 117
WP.29/2015/5

$$P_t = P_r (0.75)^{1.25} = (0.7)P_r$$

P_r is the reference pressure corresponding to the maximum load capacity Q_r

Check the tyre pressure just prior to testing at ambient temperature."

Comment [AR88]: Revision 2 - Amendment 2
 Supplement 2 to the 02 series of amendments – Date of entry into force: 15 July 2013
 WP.29/2012/54

3.23.3.1.5. Instrumentation

The vehicle shall be fitted with calibrated sensors suitable for measurements in winter. There shall be a data acquisition system to store measurements.

The accuracy of measurement sensors and systems shall be such that the relative uncertainty of the measured or computed mean fully developed decelerations is less than 1 per cent.

3.23.3.2. Testing sequences

3.23.3.2.1. For every candidate tyre and the standard reference tyre, ABS-braking test runs shall be repeated a minimum of 6 times.

The zones where ABS-braking is fully applied shall not overlap.

When a new set of tyres is tested, the runs are performed after shifting aside the vehicle trajectory in order not to brake on the tracks of the previous tyre.

When it is no longer possible not to overlap full ABS-braking zones, the test course shall be re-groomed.

Required sequence:

- 6 repeats SRTT, then shift aside to test next tyre on fresh surface
- 6 repeats Candidate 1, then shift aside
- 6 repeats Candidate 2, then shift aside
- 6 repeats SRTT, then shift aside

3.23.3.2.2. Order of testing:

If only one candidate tyre is to be evaluated, the order of testing shall be:

R1 - T - R2

Where:

R1 is the initial test of the SRTT, **R2** is the repeat test of the SRTT and **T** is the test of the candidate tyre to be evaluated.

A maximum of two candidate tyres may be tested before repeating the SRTT test, for example:

R1 - T1 - T2 - R2.

3.23.3.2.3. The comparative tests of SRTT and candidate tyres shall be repeated on two different days.

3.23.3.3. Test procedure

3.23.3.3.1. Drive the vehicle at a speed not lower than 28 km/h.

3.23.3.3.2. When the measuring zone has been reached, the vehicle gear is set into neutral, the brake pedal is depressed sharply by a constant force sufficient to cause operation of the ABS on all wheels of the vehicle and to result in stable deceleration of the vehicle and held down until the speed is lower than 8 km/h.

3.23.3.3.3. The mean fully developed deceleration between 25 km/h and 10 km/h shall be computed from time, distance, speed, or acceleration measurements.

3.23.3.4. Data evaluation and presentation of results

3.23.3.4.1. Parameters to be reported

3.23.3.4.1.1. For each tyre and each braking test, the mean and standard deviation of the mfdd shall be computed and reported.

The coefficient of variation CV of a tyre braking test shall be computed as:

$$CV(\text{tyre}) = \frac{\text{Std.dev}(\text{tyre})}{\text{Mean}(\text{tyre})}$$

3.23.3.4.1.2. Weighted averages of two successive tests of the SRTT shall be computed taking into account the number of candidate tyres in between:

In the case of the order of testing R1 - T - R2, the weighted average of the SRTT to be used in the comparison of the performance of the candidate tyre shall be taken to be:

$$\text{wa}(\text{SRTT}) = (\text{R1} + \text{R2})/2$$

Where:

R1 is the mean mfdd for the first test of the SRTT and R2 is the mean mfdd for the second test of the SRTT.

In the case of the order of testing R1 - T1 - T2 - R2, the weighted average (wa) of the SRTT to be used in the comparison of the performance of the candidate tyre shall be taken to be:

wa (SRTT) = 2/3 R1 + 1/3 R2 for comparison with the candidate tyre T1; and:

wa (SRTT) = 1/3 R1 + 2/3 R2 for comparison with the candidate tyre T2.

3.23.3.4.1.3. The snow grip index (SG) of a candidate tyre shall be computed as:

$$\text{Snow Grip Index (candidate)} = \frac{\text{Mean (candidate)}}{\text{wa (SRTT)}}$$

3.23.3.4.2. Statistical validations

The sets of repeats of measured or computed mfdd for each tyre should be examined for normality, drift, eventual outliers.

The consistency of the means and standard-deviations of successive braking tests of SRTT should be examined.

The means of two successive SRTT braking tests shall not differ by more than 5 per cent.

Comment [AR89]: Revision 2 - Amendment 2
Supplement 2 to the 02 series of amendments – Date of entry into force: 15 July 2013
WP.29/2012/54

The coefficient of variation of any braking test shall be less than 6 per cent.

If those conditions are not met, tests shall be performed again after re-grooming the test course.

3.23.3.4.3. In the case where the candidate tyres cannot be fitted to the same vehicle as the SRTT, for example, due to tyre size, inability to achieve required loading and so on, comparison shall be made using intermediate tyres, hereinafter referred to as "control tyres", and two different vehicles. One vehicle shall be capable of being fitted with the SRTT and the control tyre and the other vehicle shall be capable of being fitted with the control tyre and the candidate tyre.

3.23.3.4.3.1 The snow grip index of the control tyre relative to the SRTT (SG1) and of the candidate tyre relative to the control tyre (SG2) shall be established using the procedure in paragraphs 3.23.3.1. to 3.23.3.4.2.

The snow grip index of the candidate tyre relative to the SRTT shall be the product of the two resulting snow grip indices that is SG1 x SG2.

3.23.3.4.3.2. The ambient conditions shall be comparable. All tests shall be completed within the same day.

3.23.3.4.3.3. The same set of control tyres shall be used for comparison with the SRTT and with the candidate tyre and shall be fitted in the same wheel positions.

3.23.3.4.3.4. Control tyres that have been used for testing shall subsequently be stored under the same conditions as required for the SRTT.

3.23.3.4.3.5. The SRTT and control tyres shall be discarded if there is irregular wear or damage or when the performance appears to have been deteriorated."

3.23.4. Acceleration method for Class C3 tyres

3.23.4.1. According to the definition of C3 tyres reported into paragraph 3.23.3.4.3., the additional classification for the purpose of this test method only applies:

- (a) C3 Narrow (C3N), when the C3 tyre Nominal Section Width is lower than 285 mm
- (b) C3Wide (C3W), when the C3 tyre Nominal Section Width is greater or equal to 285 mm

3.23.4.2. Methods for measuring Snow Grip Index

Snow performance is based on a test method by which the average acceleration in an acceleration test, of a candidate tyre is compared to that of a standard reference tyre.

The relative performance shall be indicated by a Snow Grip Index (SG).

When tested in accordance with the acceleration test in paragraph 3.23.4.7., the average acceleration of a candidate snow tyre shall be at least 1.25 compared to one of the two equivalent SRTTs – ASTM F 2870 and ASTM F 2871.

3.23.4.3. Measuring equipment

Comment [AR90]: Revision 2 - Amendment 2
 Supplement 2 to the 02 series of amendments – Date of entry into force: 15 July 2013
 WP.29/2012/54

Comment [AR91]: Revision 2 – Amendment 1
 Supplement 1 to the 02 series of amendments - Date of entry into force: 18 November 2012
 WP.29/2012/2 amended by para 65 of ECE/TRANS/WP.29/1095

3.23.4.3.1. A sensor suitable for measuring speed and distance covered on snow/ice surface between two speeds must be used.

To measure vehicle speed, a fifth wheel or non-contact speed-measuring system (including radar, GPS ...) shall be used.

3.23.4.3.2. The following tolerances shall be respected:

(a) For speed measurements : ± 1 per cent (km/h) or 0.5 km/h whichever is greater.

(b) For distance measurements: $\pm 1 \times 10^{-1}$ m

3.23.4.3.3. A display of the measured speed or the difference between the measured speed and the reference speed for the test is recommended inside the vehicle so that the driver can adjust the speed of the vehicle.

3.23.4.3.4. For Acceleration test covered in paragraph 3.23.4.7., a display of the slip ratio of the driven tyres is recommended inside the vehicle and shall be used in the particular case of paragraph 3.23.5.7.2.1.1.

The slip ratio is calculated by

$$\text{Slip Ratio \%} = \left[\frac{\text{Wheel Speed} - \text{Vehicle Speed}}{\text{Vehicle Speed}} \right] \times 100$$

(a) Vehicle speed is measured as defined in 3.23.4.3.1 (m/s)

(b) Wheel speed is calculated on a tyre of the driven axle by measuring its angular velocity and its loaded diameter

$$\text{Wheel Speed} = \pi \times \text{loaded diameter} \times \text{angular speed}$$

Where, $\pi = 3.1416$ (m/360deg), the loaded diameter (m) and the angular speed (revolution per second = 360 deg/sec).

3.23.4.3.5. A data acquisition system can be used for storing the measurements.

3.23.4.4. General conditions

3.23.4.4.1. Test course

The test shall be done on a flat test surface of sufficient length and width, with a maximum 2 per cent gradient, covered with packed snow.

3.23.4.4.1.1 The snow surface shall be composed of a hard packed snow base at least 3 cm thick and a surface layer of medium packed and prepared snow about 2 cm thick.

3.23.4.4.1.2. The snow compaction index measured with a CTI penetrometer shall be between 80 and 90. Refer to the appendix of ASTM F1805 for additional details on measuring method.

3.23.4.4.1.3. The air temperature, measured about one meter above the ground, shall be between -2 °C and -15 °C; the snow temperature, measured at a depth of about one centimetre, shall be between -4 °C and -15 °C.

Air temperature shall not vary more than 10 deg C during the test.

3.23.4.5. Tyres preparation and break-in

3.23.4.5.1. Fit the test tyres on rims as per ISO 4209-1 using conventional mounting methods. Ensure proper bead seating by the use of a suitable lubricant.

Excessive use of lubricant should be avoided to prevent slipping of the tyre on the wheel rim.

3.23.4.5.2. The tyres should be "broken-in" prior to testing to remove spew, compound nodules or flashes resulting from moulding process.

3.23.4.5.3. Tyres shall be conditioned at the outdoor ambient temperature at least two hours before their mounting for tests.

They should be placed such that they all have the same ambient temperature prior to testing and be shielded from the sun to avoid excessive heating by solar radiation.

The tyre surface in contact with snow shall be cleaned before performing a test.

Tyre pressures shall then be adjusted to the values specified for the test.

3.23.4.6. Testing sequence

If only one candidate tyre is to be evaluated, the order of testing shall be:

R1, T, R2

where:

R1 is the initial test of the SRTT, R2 is the repeat test of the SRTT and T is the test of the candidate tyre to be evaluated.

A maximum of 3 candidate tyres may be tested before repeating the SRTT test, for example: R1, T1, T2, T3, R2.

Recommendations are that the zones where acceleration is fully applied shall not overlap without reworking and when a new set of tyres is tested;

The runs are performed after shifting the vehicle trajectory in order not to accelerate on the tracks of the previous tyre; when it is no longer possible not to overlap full acceleration zones, the test course should be re-groomed.

3.23.4.7. Acceleration on Snow Test Procedure for Snow Grip Index of Class C3N and C3W

3.23.4.7.1. Principle

The test method covers a procedure for measuring the Snow Grip performance of commercial vehicle tyres during acceleration, using a commercial vehicle having a Traction Control System (TCS, ASR, etc.).

Starting with a defined initial speed, the full throttle is applied to activate the Traction Control system, the Average acceleration is calculated between two defined speeds.

3.23.4.7.2. Vehicle

3.23.4.7.2.1 The test shall be conducted with a standard 2 axle commercial vehicle in good running order with:

- (a) Low rear axle weight and an engine powerful enough to maintain the average percentage of slip during the test as required in paragraphs 3.23.4.7.5.1. and 3.23.4.7.5.2.1. below;

- (b) A manual gearbox (automatic gearbox with manual shift allowed) having a gear ratio covering the speed range of at least 19 km/h between 4 km/h and 30 km/h;
- (c) Differential lock on driven axle is recommended to improve repeatability;
- (d) A standard commercial system controlling/limiting the slip of the driving axle during acceleration (Traction Control, ASR, TCS, etc.)."

3.23.4.7.2.1.1. In the particular case where a standard commercial vehicle equipped with a traction control system is not available, a vehicle without Traction Control/ASR/TCS is permitted provided the vehicle is fitted with a system to display the percentage slip as stated in paragraph 3.23.4.3.4. of this annex and a mandatory differential lock on the driven axle used in accordance with operating procedure 4.7.4.2.1. below. If a differential lock is available it shall be used; if the differential lock, however, is not available, the average slip ratio should be measured on the left and right driven wheel.

3.23.4.7.2.2. The permitted modifications are:

- (a) Those allowing to increase the number of tyre sizes capable to be mounted on the vehicle;
- (b) Those permitting to install an automatic activation of the acceleration and the measurements.

Any other modification of the acceleration system is prohibited.

3.23.4.7.3. Vehicle fitting

The rear driven axle may be indifferently fitted with 2 or 4 test tyres if respecting the loading by tyre.

The front steer non driven axle is equipped with 2 tyres having a size suitable for the axle load. These 2 front tyres could be maintained along the test.

3.23.4.7.4. Load and inflation pressure

3.23.4.7.4.1. The static load on each rear driven test tyres must be between 20 per cent and 55 per cent of the tested tyre load capacity written on the sidewall.

The vehicle front steer total static axle load should be between 60 per cent and 160 per cent of the driven rear total axle load.

The static tyre load on the same driven axle should not differ by more than 10 per cent.

3.23.4.7.4.2. The driven tyres inflation pressure shall be 70 per cent of the one written on the sidewall.

The steer tyres are inflated at nominal sidewall pressure.

If the pressure is not marked on the sidewall, refer to the specified pressure in applicable tyre standards manuals corresponding to maximum load capacity.

3.23.4.7.5. Testing Runs

Comment [AR92]: Revision 3 - Amendment 1
Supplement 5 to the 02 series of amendments – Date of entry into force: 10 June 2014
WP.29/2013/59

Comment [AR93]: Revision 3 - Amendment 1
Supplement 5 to the 02 series of amendments – Date of entry into force: 10 June 2014
WP.29/2013/59

Comment [AR94]: Revision 3 - Amendment 1
Supplement 5 to the 02 series of amendments – Date of entry into force: 10 June 2014
WP.29/2013/59

3.23.4.7.5.1. Mount first the set of reference tyres on the vehicle and when on the testing area.

Drive the vehicle at a constant speed between 4 km/h and 11 km/h and the gear ratio capable of covering the speed range of at least 19 km/h for the complete test programme (e.g. R-T1-T2-T3-R).

The Recommended Gear ratio selected is 3rd or 4th and shall give a minimum 10 per cent average slip ratio in the measured range of speed.

3.23.4.7.5.2. In case of Traction Control system equipped vehicles (already switched "on" before the run) apply full throttle until the vehicle has reached the final speed.

Final speed = Initial speed + 15 km/h

No rearward restraining force shall be applied to the test vehicle.

3.23.4.7.5.2.1. In the particular case of paragraph 3.23.4.7.2.1.1. of this annex where a standard commercial vehicle equipped with a Traction Control system is not available, the driver shall manually maintain the average slip ratio between 10 and 40 per cent (Controlled Slip procedure in place of the Full Slip) within the prescribed range of speeds. If a differential lock is not available, the averaged slip ratio difference between the left and right driven wheel shall not be higher than 8 per cent for each run. All the tyres and runs in the test session are performed with Controlled Slip procedure.

3.23.4.7.5.3. Measure the distance between the initial speed and the final speed.

3.23.4.7.5.4. For every candidate tyre and the standard reference tyre, the acceleration test runs shall be repeated a minimum of 6 times and the coefficients of variation (standard deviation/average*100) calculated for minimum 6 valid runs on the distance shall be lower than or equal to 6 per cent.

3.23.4.7.5.5 In case of Traction Control System equipped vehicle, the Average Slip ratio shall be in the range from 10 per cent to 40 per cent (calculated as per paragraph 3.23.4.3.4.).

3.23.4.7.5.6. Apply testing sequence as defined in paragraph 3.23.4.6.

3.23.4.8. Processing of measurement results

3.23.4.8.1. Calculation of the Average Acceleration AA

Each time the measurement is repeated, the average acceleration AA (m · s⁻²) is calculated by

$$AA = \frac{S_f^2 - S_i^2}{2D}$$

Where D (m) is the distance covered between the initial speed S_i (m.s⁻¹) and the final speed S_f (m.s⁻¹).

3.23.4.8.2. Validation of results

For the candidate tyres:

Comment [AR95]: Revision 3 - Amendment 1
Supplement 5 to the 02 series of amendments – Date of entry into force: 10 June 2014
WP.29/2013/59

Comment [AR96]: Revision 3 - Amendment 1
Supplement 5 to the 02 series of amendments – Date of entry into force: 10 June 2014
WP.29/2013/59

Comment [AR97]: Revision 3 - Amendment 1
Supplement 5 to the 02 series of amendments – Date of entry into force: 10 June 2014
WP.29/2013/59

Comment [AR98]: Revision 3 - Amendment 1
Supplement 5 to the 02 series of amendments – Date of entry into force: 10 June 2014
WP.29/2013/59

Comment [AR99]: Revision 3 - Amendment 1
Supplement 5 to the 02 series of amendments – Date of entry into force: 10 June 2014
WP.29/2013/59

The coefficients of variation of the Average Acceleration is calculated for all the candidate tyres. If one coefficient of variation is greater than 6 per cent, discard the data for this candidate tyre and repeat the test.

$$\text{coefficient of variation} = \frac{\text{stdev}}{\text{average}} \times 100$$

For the reference tyre:

If the coefficient of variation of the average Acceleration "AA" for each group of min 6 runs of the reference tyre is higher than 6 per cent, discard all data and repeat the test for all tyres (the candidate tyres and the reference tyre).

In addition and in order to take in account possible test evolution, the coefficient of validation is calculated on the basis of the average values of any two consecutive groups of min 6 runs of the reference tyre. If the coefficient of validation is greater than 6 per cent, discard the data for all the candidate tyres and repeat the test.

$$\text{coefficient of validation} = \frac{|\text{Average2} - \text{Average1}|}{\text{Average1}} \times 100$$

3.23.4.8.3. Calculation of the "average AA"

If R1 is the average of the "AA" values in the first test of the reference tyre, R2 is the average of the "AA" values in the second test of the reference tyre, the following operations are performed, according to Table 1:

Table 1

<i>If the number of sets of candidate tyres between two successive runs of the reference tyre is:</i>	<i>and the set of candidate tyres to be qualified is:</i>	<i>then "Ra" is calculated by applying the following:</i>
1 R - T1 - R	T1	Ra = 1/2 (R1 + R2)
2 R - T1 - T2 - R	T1 T2	Ra = 2/3 R1 + 1/3 R2 Ra = 1/3 R1 + 2/3 R2
3 R - T1 - T2 - T3 - R	T1 T2 T3	Ra = 3/4 R1 + 1/4 R2 Ra = 1/2 (R1 + R2) Ra = 1/4 R1 + 3/4 R2

"Ta" (a = 1, 2, ...) is the average of the AA values for a test of a candidate tyre.

3.23.4.8.4 "AFC" Calculation (Acceleration Force Coefficient)

Also called AFC Acceleration Force Coefficient

Calculation on of AFC(Ta) and AFC(Ra) as defined in table 2 :

Comment [AR100]: Revision 2 - Amendment 2
Supplement 2 to the 02 series of amendments - Date of entry into force: 15 July 2013

Table 2

	The Acceleration Force Coefficient "AFC" is:
Reference tyre	$AFC(R) = \frac{Ra}{g}$
Candidate tyre	$AFC(T) = \frac{Ta}{g}$
<i>Ra and Ta are in m/s²</i> <i>"g"= gravity acceleration (rounded to 9.81 m/s²)</i>	

3.23.4.8.5. Calculation of the relative Snow Grip Index of the tyre

The Snow grip index represents the relative performance of the candidate tyre compared to the reference tyre.

$$\text{Snow Grip Index} = \frac{AFC(T)}{AFC(R)}$$

3.23.4.8.6. Calculation of the Slip Ratio

The slip ratio can be calculated as the average of Slip ratio as mentioned in paragraph 3.23.4.3.4. of this annex or by comparing the average distance referred to in paragraph 3.23.4.7.5.3. of this annex of the minimum 6 runs to the distance of a run done without slip (very low acceleration)

$$\text{Slip Ratio \%} = \left[\frac{\text{Average distance} - \text{No slip distance}}{\text{No slip distance}} \right] \times 100$$

No slip distance means the wheel distance calculated on a run done with a constant speed or a continuous low acceleration.

3.23.4.9. Snow grip performance comparison between a candidate tyre and a reference tyre using a control tyre

3.23.4.9.1. Scope

When the candidate tyre size is significantly different from the reference tyre a direct comparison on the same vehicle may be not possible. This is an approach using an intermediate tyre, hereinafter called the control tyre.

3.23.4.9.2. Principle of the approach

The principle lies upon the use of a control tyre and 2 different vehicles for the assessment of a candidate tyre in comparison with a reference tyre.

One vehicle can fit the reference tyre and the control tyre, the other the control tyre and the candidate tyre. All conditions are in conformity with paragraph 3.23.4.7.

The first assessment is a comparison between the control tyre and the reference tyre. The result (Snow Grip Index 1) is the relative efficiency of the control tyre compared to the reference tyre.

Comment [AR101]: Revision 2 – Amendment 1
 Supplement 1 to the 02 series of amendments - Date of entry into force: 18 November 2012
 WP.29/2012/2 amended by para 65 of ECE/TRANS/WP.29/1095

Comment [AR102]: Revision 3 - Amendment 1
 Supplement 5 to the 02 series of amendments – Date of entry into force: 10 June 2014
 WP.29/2013/59

The second assessment is a comparison between the candidate tyre and the control tyre. The result (Snow grip index 2) is the relative efficiency of the candidate tyre compared to the control tyre.

The second assessment is done on the same track as the first one. The air temperature must be in the range of +/- 5 deg C of the temperature of the first assessment. The control tyre set is the same set as the set used for the first assessment.

The Snow Grip performance Index of the candidate tyre compared to the reference tyre is deduced by multiplying the relative efficiencies calculated above:

$$\text{Snow Grip Index} = \text{SG1} \times \text{SG2}$$

3.23.4.9.3. Selection of a set of tyres as a control tyre set

A control tyre set is a group of identical tyres made in the same factory during one week period.

3.23.4.10. Storage and preservation

Before the first assessment (control tyre / reference tyre), normal storage conditions can be used. It is necessary that all the tyres of a control tyre set have been stored in the same conditions.

As soon as the control tyre set has been assessed in comparison with the reference tyre, specific storage conditions shall be applied for Control tyres replacement.

When irregular wear or damage results from tests, or when wear influences the test results, the use of the tyre shall be discontinued.

Comment [AR103]: Revision 2 – Amendment 1
Supplement 1 to the 02 series of amendments - Date of entry into force: 18 November 2012
WP.29/2012/2

Annex 1

Speed symbol table

<i>Speed symbol</i>	<i>Corresponding speed km/h</i>
F	80
G	90
J	100
K	110
L	120
M	130
N	140
P	150
Q	160
R	170
S	180
T	190
U	200
H	210
V	240
W	270
Y	300

Annex 2

Load Index (LI) and equivalent load capacity table

<i>LI</i>	<i>Kg</i>	<i>LI</i>	<i>kg</i>	<i>LI</i>	<i>kg</i>	<i>LI</i>	<i>kg</i>	<i>LI</i>	<i>kg</i>
0	45	27	97.5	54	212	81	462	108	1 000
1	46.2	28	100	55	218	82	475	109	1 030
2	47.5	29	103	56	224	83	487	110	1 060
3	48.7	30	106	57	230	84	500	111	1 090
4	50.0	31	109	58	236	85	515	112	1 120
5	51.5	32	112	59	243	86	530	113	1 150
6	53.0	33	115	60	250	87	545	114	1 180
7	54.5	34	118	61	257	88	560	115	1 215
8	56.0	35	121	62	265	89	580	116	1 250
9	58.0	36	125	63	272	90	600	117	1 285
10	60.0	37	128	64	280	91	615	118	1 320
11	61.5	38	132	65	290	92	630	119	1 360
12	63.0	39	136	66	300	93	650	120	1 400
13	65.0	40	140	67	307	94	670	121	1 450
14	67.0	41	145	68	315	95	690	122	1 500
15	69.0	42	150	69	325	96	710	123	1 550
16	71.0	43	155	70	335	97	730	124	1 600
17	73.0	44	160	71	345	98	750	125	1 650
18	75.0	45	165	72	355	99	775	126	1 700
19	77.5	46	170	73	365	100	800	127	1 750
20	80.0	47	175	74	375	101	825	128	1 800
21	82.5	48	180	75	387	102	850	129	1 850
22	85.0	49	185	76	400	103	875	130	1 900
23	87.5	50	190	77	412	104	900		
24	90.0	51	195	78	425	105	925		
25	92.5	52	200	79	437	106	950		
26	95.0	53	206	80	450	107	975		

Annex 3

Nominal rim diameter code table

<i>Nominal rim diameter code ("d" symbol)</i>	<i>Value of the "d" symbol expressed in mm</i>
8	203
9	229
10	254
11	279
12	305
13	330
14	356
14.5	368
15	381
16	406
16.5	419
17	432
17.5	445
18	457
19	482
19.5	495
20	508
20.5	521
21	533
22	559
22.5	572
23	584
24	610
24.5	622
25	635
26	660
28	711
30	762

Annex 4

Relation between the pressure index ('psi') and the units of pressure (kPa)

<i>kPa</i>	<i>psi</i>	<i>kPa</i>	<i>psi</i>	<i>kPa</i>	<i>psi</i>	<i>kPa</i>	<i>psi</i>
10	1	270	39	530	77	790	115
15	2	275	40	540	78	800	116
20	3	280	41	545	79	810	117
25	4	290	42	550	80	815	118
35	5	295	43	560	81	820	119
40	6	300	44	565	82	825	120
45	7	310	45	575	83	835	121
55	8	320	46	580	84	840	122
60	9	325	47	585	85	850	123
70	10	330	48	590	86	855	124
75	11	340	49	600	87	860	125
80	12	345	50	610	88	870	126
90	13	350	51	615	89	875	127
95	14	360	52	620	90	880	128
100	15	365	53	625	91	890	129
110	16	375	54	635	92	900	130
120	17	380	55	640	93	905	131
125	18	385	56	650	94	910	132
130	19	390	57	655	95	920	133
140	20	400	58	660	96	925	134
145	21	410	59	670	97	930	135
150	22	415	60	675	98	940	136
160	23	420	61	680	99	945	137
165	24	425	62	690	100	950	138
170	25	435	63	695	101	960	139
180	26	440	64	700	102	965	140
185	27	450	65	710	103	975	141
190	28	455	66	720	104	980	142
200	29	460	67	725	105	985	143
210	30	470	68	730	106	990	144
215	31	475	69	740	107	1,000	145
220	32	480	70	745	108	1,010	146
230	33	490	71	750	109	1,015	147
235	34	495	72	760	110	1,020	148

<i>kPa</i>	<i>psi</i>	<i>kPa</i>	<i>psi</i>	<i>kPa</i>	<i>psi</i>	<i>kPa</i>	<i>psi</i>
240	35	500	73	765	111	1,030	149
250	36	510	74	775	112	1,035	150
255	37	520	75	780	113	1,040	151
260	38	525	76	785	114	1,050	152

Annex 5

Variation of load capacity with speed commercial vehicles tyres

Variation of load capacity (per cent)										
Speed (km/h)	All load indices				Load indices $\geq 122^1$		Load indices $\leq 121^1$			
	Tyre speed symbol				Tyre speed symbol		Tyre speed symbol			
	F	G	J	K	L	M	L	M	N	P ²
0	+150	+150	+150	+150	+150	+150	+110	+110	+110	+110
5	+110	+110	+110	+110	+110	+110	+90	+90	+90	+90
10	+80	+80	+80	+80	+80	+80	+75	+75	+75	+75
15	+65	+65	+65	+65	+65	+65	+60	+60	+60	+60
20	+50	+50	+50	+50	+50	+50	+50	+50	+50	+50
25	+35	+35	+35	+35	+35	+35	+42	+42	+42	+42
30	+25	+25	+25	+25	+25	+25	+35	+35	+35	+35
35	+19	+19	+19	+19	+19	+19	+29	+29	+29	+29
40	+15	+15	+15	+15	+15	+15	+25	+25	+25	+25
45	+13	+13	+13	+13	+13	+13	+22	+22	+22	+22
50	+12	+12	+12	+12	+12	+12	+20	+20	+20	+20
55	+11	+11	+11	+11	+11	+11	+17.5	+17.5	+17.5	+17.5
60	+10	+10	+10	+10	+10	+10	+15.0	+15.0	+15.0	+15.0
65	+7.5	+8.5	+8.5	+8.5	+8.5	+8.5	+13.5	+13.5	+13.5	+13.5
70	+5.0	+7.0	+7.0	+7.0	+7.0	+7.0	+12.5	+12.5	+12.5	+12.5
75	+2.5	+5.5	+5.5	+5.5	+5.5	+5.5	+11.0	+11.0	+11.0	+11.0
80	0	+4.0	+4.0	+4.0	+4.0	+4.0	+10.0	+10.0	+10.0	+10.0
85	-3	+2.0	+3.0	+3.0	+3.0	+3.0	+8.5	+8.5	+8.5	+8.5
90	-6	0	+2.0	+2.0	+2.0	+2.0	+7.5	+7.5	+7.5	+7.5
95	-10	-2.5	+1.0	+1.0	+1.0	+1.0	+6.5	+6.5	+6.5	+6.5
100	-15	-5	0	0	0	0	+5.0	+5.0	+5.0	+5.0
105		-8	-2	0	0	0	+3.75	+3.75	+3.75	+3.75
110		-13	-4	0	0	0	+2.5	+2.5	+2.5	+2.5
115			-7	-3	0	0	+1.25	+1.25	+1.25	+1.25
120			-12	-7	0	0	0	0	0	0
125						0	-2.5	0	0	0

¹ The load capacity indices refer to a single operation.

² Load variations are not allowed for speeds above 160 km/h. For tyre speed symbols "Q" and above the speed corresponding to the tyre speed symbol (Annex 1) specifies the maximum speed permitted for the tyre.

Variation of load capacity (per cent)									
Speed (km/h)	All load indices				Load indices $\geq 122^1$	Load indices $\leq 121^1$			
	Tyre speed symbol				Tyre speed symbol	Tyre speed symbol			
130					0	-5.0	0	0	0
135						-7.5	-2.5	0	0
140						-10	-5	0	0
145							-7.5	-2.5	0
150							-10.0	-5.0	0
155								-7.5	-2.5
160								-10.0	-5.0

Comment [JN104]: Agreement given during GRRF 80th session to delete the annex as being not referred to in the text.

Annex 6

Specifications for the rolling sound emissions test site

1. Introduction

This annex describes the specifications relating to the physical characteristics and the laying of the test track. These specifications based on a special standard¹ describe the required physical characteristics as well as the test methods for these characteristics.

2. Required characteristics of the surface

A surface is considered to conform to this standard provided that the texture and voids content or sound absorption coefficient have been measured and found to fulfil all the requirements of paragraphs 2.1. to 2.4. below and provided that the design requirements (paragraph 3.2.) have been met.

2.1. Residual voids content

The residual voids content (VC) of the test track paving mixture shall not exceed 8 per cent. For the measurement procedure, see paragraph 4.1.

2.2. Sound absorption coefficient

If the surface fails to comply with the residual voids content requirement, the surface is acceptable only if its sound absorption coefficient $\alpha \leq 0.10$. For the measurement procedure, see paragraph 4.2. The requirements of paragraphs 2.1. and 2.2. are met also if only sound absorption has been measured and found to be $\alpha \leq 0.10$.

Note: The most relevant characteristic is the sound absorption, although the residual voids content is more familiar among road constructors. However, sound absorption needs to be measured only if the surface fails to comply with the voids requirement. This is motivated because the latter is connected with relatively large uncertainties in terms of both measurements and relevance and some surfaces therefore erroneously may be rejected when based only on the voids measurement.

2.3. Texture depth

The Texture Depth (TD) measured according to the volumetric method (see paragraph 4.3. below) shall be:

$$TD \geq 0.4 \text{ mm}$$

2.4. Homogeneity of the surface

Every practical effort shall be taken to ensure that the surface is made to be as homogeneous as possible within the test area. This includes the texture and voids content, but it should also be observed that if the rolling process results in more effective rolling at some places than others, the texture may be different and unevenness causing bumps may also occur.

¹ ISO 10844:1994. If a different test surface is defined, in the future, the reference standard will be amended accordingly.

2.5. ~~Period of testing~~

~~In order to check whether the surface continues to conform to the texture and voids content or sound absorption requirements stipulated in this standard, periodic testing of the surface shall be done at the following intervals:~~

~~(a) — For residual Voids Content (VC) or sound absorption (α):~~

~~When the surface is new;~~

~~If the surface meets the requirements when new, no further periodical testing is required. If it does not meet the requirement when it is new, it may do later because surfaces tend to become clogged and compacted with time.~~

~~(b) — For Texture Depth (TD):~~

~~When the surface is new;~~

~~When the noise testing starts (NB: not before four weeks after laying);~~

~~Then every twelve months.~~

3. ~~Test surface design~~

3.1. ~~Area~~

~~When designing the test track layout it is important to ensure that, as a minimum requirement, the area traversed by the vehicles running through the test strip is covered with the specified test material with suitable margins for safe and practical driving. This will require that the width of the track is at least 3 m and the length of the track extends beyond lines AA and BB by at least 10 m at either end. Figure 1 shows a plan of a suitable test site and indicates the minimum area which shall be machine laid and machine compacted with the specified test surface material. According to Annex 3 to this Regulation, paragraph 3.2., measurements have to be made on each side of the vehicle. This can be made either by measuring with two microphone locations (one on each side of the track) and driving in one direction, or measuring with a microphone only on one side of the track but driving the vehicle in two directions. If the latter method is used, then there are no surface requirements on that side of the track where there is no microphone.~~

Figure 1
Minimum requirements for test surface area
(The shaded part is called "Test Area")

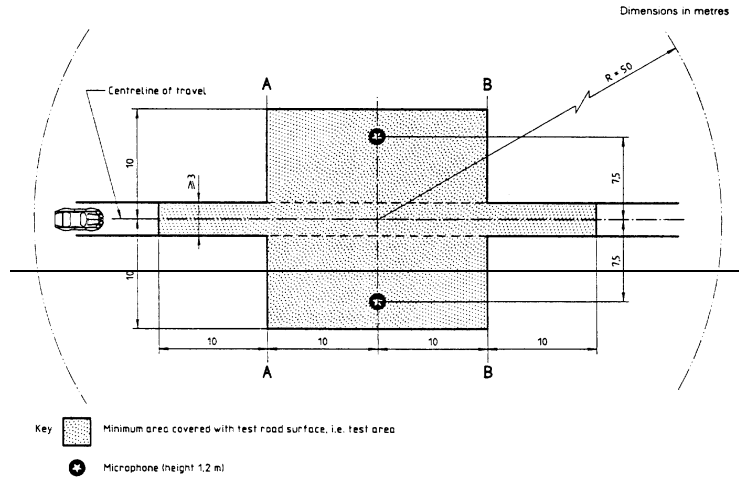

NOTE — There shall be no large acoustically reflective objects within this radius.

3.2. Design and preparation of the surface

3.2.1. Basic design requirements

The test surface shall meet four design requirements:

- 3.2.1.1. It shall be a dense asphaltic concrete.
- 3.2.1.2. The maximum chipping size shall be 8 mm (tolerances allow from 6.3 mm to 10 mm).
- 3.2.1.3. The thickness of the wearing course shall be ≥ 30 mm.
- 3.2.1.4. The binder shall be straight penetration grade bitumen without modification.

3.2.2. Design guidelines

3.2.2.1. As a guide to the surface constructor, an aggregate grading curve which will give desired characteristics is shown in Figure 2. In addition, Table 1 gives some guidelines in order to obtain the desired texture and durability. The grading curve fits the following formula:

$$P (\% \text{ passing}) = 100 \times (d/d_{\max})^{1.2}$$

Where:

- d = square mesh sieve size, in mm
- d_{\max} = 8 mm for the mean curve
- = 10 mm for the lower tolerance curve
- = 6.3 mm for the upper tolerance curve

Figure 2
Grading curve of the aggregate in the asphaltic mix with tolerances

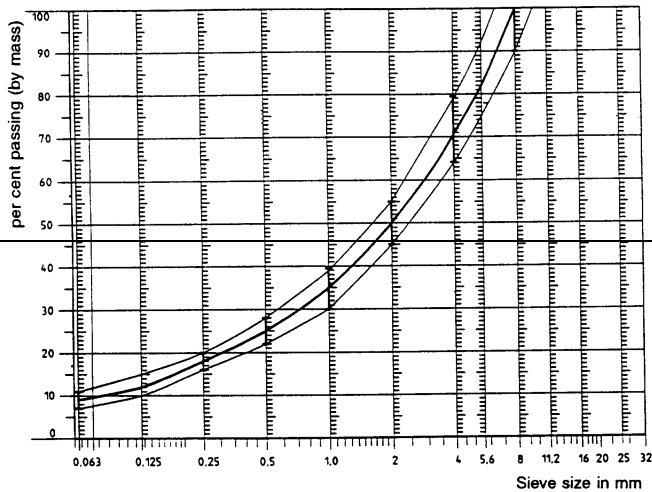

3.2.2.2. In addition to the above, the following recommendations are given:

- (a) The sand fraction (0.063 mm < square mesh sieve size < 2 mm) shall include no more than 55 per cent natural sand and at least 45 per cent crushed sand.
- (b) The base and sub base shall ensure a good stability and evenness, according to best road construction practice.
- (c) The chippings shall be crushed (100 per cent crushed faces) and of a material with a high resistance to crushing.
- (d) The chippings used in the mix shall be washed.
- (e) No extra chippings shall be added onto the surface.
- (f) The binder hardness expressed as PEN value shall be 40-60, 60-80 or even 80-100 depending on the climatic conditions of the country. The rule is that as hard a binder as possible shall be used, provided this is consistent with common practice.
- (g) The temperature of the mix before rolling shall be chosen so as to achieve by subsequent rolling the required voids content. In order to increase the probability of satisfying the specifications of paragraphs 2.1. to 2.4. above, the compactness shall be studied not only by an appropriate choice of mixing temperature, but also by an appropriate number of passings and by the choice of compacting vehicle.

Table 1
Design guidelines

	Target values		Tolerances
	By total mass of mix	By mass of the aggregate	
Mass of stones, square mesh sieve (SM) > 2 mm	47.6 %	50.5 %	±5
Mass of sand 0.063 < SM < 2 mm	38.0 %	40.2 %	±5
Mass of filler SM < 0.063 mm	8.8 %	9.3 %	±5
Mass of binder (bitumen)	5.8 %	N.A.	±0.5
Max. chipping size	8 mm		6.3 – 10
Binder hardness	(see para. 3.2.2. (f))		
Polished stone value (PSV)	> 50		
Compactness, relative to Marshall compactness	98 %		

4. _____ Test method

4.1. _____ Measurement of the residual voids content

For the purpose of this measurement, cores have to be taken from the track in at least four different positions, which are equally distributed in the test area between lines AA and BB (see Figure 1). In order to avoid inhomogeneity and unevenness in the wheel tracks, cores should not be taken in wheel tracks themselves, but close to them. Two cores (minimum) should be taken close to the wheel tracks and one core (minimum) should be taken approximately midway between the wheel tracks and each microphone location.

If there is a suspicion that the condition of homogeneity is not met (see paragraph 2.4.), cores shall be taken from more locations within the test area.

The residual voids content has to be determined for each core, then the average value from all cores shall be calculated and compared with the requirement of paragraph 2.1. In addition, no single core shall have a voids value, which is higher than 10 per cent.

The test surface constructor is reminded of the problem, which may arise when the test area is heated by pipes or electrical wires and cores shall be taken from this area. Such installations shall be carefully planned with respect to future core drilling locations. It is recommended to leave a few locations of size approximately 200 mm x 300 mm where there are no wires/pipes or where the latter are located deep enough in order not to be damaged by cores taken from the surface layer.

4.2. ~~Sound absorption coefficient~~

~~The sound absorption coefficient (normal incidence) shall be measured by the impedance tube method using the procedure specified in ISO 10534 1:1996 or ISO 10534 2:1998.~~

~~Regarding test specimens, the same requirements shall be followed as regarding the residual voids content (see paragraph 4.1.). The sound absorption shall be measured in the range between 400 Hz and 800 Hz and in the range between 800 Hz and 1,600 Hz (at least at the centre frequencies of third octave bands) and the maximum values shall be identified for both of these frequency ranges. Then these values, for all test cores, shall be averaged to constitute the final result.~~

4.3. ~~Volumetric macrotexture measurement~~

~~For the purpose of this standard, texture depth measurements shall be made on at least 10 positions evenly spaced along the wheel tracks of the test strip and the average value taken to compare with the specified minimum texture depth. See ISO 10844:1994 for description of the procedure.~~

5. ~~Stability in time and maintenance~~

5.1. ~~Age influence~~

~~In common with any other surfaces, it is expected that the tyre rolling sound level measured on the test surface may increase slightly during the first 6-12 months after construction.~~

~~The surface will achieve its required characteristics not earlier than four weeks after construction. The influence of age on the noise from trucks is generally less than that from cars.~~

~~The stability over time is determined mainly by the polishing and compaction by vehicles driving on the surface. It shall be periodically checked as stated in paragraph 2.5.~~

5.2. ~~Maintenance of the surface~~

~~Loose debris or dust, which could significantly reduce the effective texture depth, shall be removed from the surface. In countries with winter climates, salt is sometimes used for de-icing. Salt may alter the surface temporarily or even permanently in such a way as to increase noise and is therefore not recommended.~~

5.3. ~~Repaving the test area~~

~~If it is necessary to repave the test track, it is usually unnecessary to repave more than the test strip (of 3 m width in Figure 1) where vehicles are driving, provided the test area outside the strip met the requirement of residual voids content or sound absorption when it was measured.~~

6. ~~Documentation of the test surface and of tests performed on it~~

6.1. ~~Documentation of the test surface~~

~~The following data shall be given in a document describing the test surface:~~

6.1.1. ~~The location of the test track.~~

- ~~6.1.2. Type of binder, binder hardness, type of aggregate, maximum theoretical density of the concrete (DR), thickness of the wearing course and grading curve determined from cores from the test track.~~
- ~~6.1.3. Method of compaction (e.g. type of roller, roller mass, number of passes).~~
- ~~6.1.4. Temperature of the mix, temperature of the ambient air and wind speed during laying of the surface.~~
- ~~6.1.5. Date when the surface was laid and contractor.~~
- ~~6.1.6. All or at least the latest test result, including:~~
 - ~~6.1.6.1. The residual voids content of each core;~~
 - ~~6.1.6.2. The locations in the test area from where the cores for voids measurements have been taken;~~
 - ~~6.1.6.3. The sound absorption coefficient of each core (if measured). Specify the results both for each core and each frequency range as well as the overall average;~~
 - ~~6.1.6.4. The locations in the test area from where the cores for absorption measurement have been taken;~~
 - ~~6.1.6.5. Texture depth, including the number of tests and standard deviation;~~
 - ~~6.1.6.6. The institution responsible for tests according to paragraphs 6.1.6.1. and 6.1.6.2. and the type of equipment used;~~
 - ~~6.1.6.7. Date of the test(s) and date when the cores were taken from the test track.~~
- ~~6.2. Documentation of vehicle noise tests conducted on the surface~~

~~In the document describing the vehicle noise test(s) it shall be stated whether all the requirements of this standard were fulfilled or not. Reference shall be given to a document according to paragraph 6.1. describing the results which verify this.]~~

Annex 67

Tyre-size designations and dimensions

Table A
Code designated sizes mounted on 5° tapered rims or flat base rims

<i>Tyre size designation</i>	<i>Measuring rim width Code</i>	<i>Nominal rim diameter d (mm)</i>	<i>Outer diameter D (mm)</i>	<i>Section width S (mm)</i>
<i>Std. series</i>			<i>Radial</i>	<i>Radial</i>
4.00R8 (*)	2.50	203	414	107
4.00R10(*)	3.00	254	466	108
4.00R12(*)	3.00	305	517	108
4.50R8 (*)	3.50	203	439	125
4.50R10(*)	3.50	254	490	125
4.50R12(*)	3.50	305	545	125
5.00R8 (*)	3.00	203	467	132
5.00R10(*)	3.50	254	516	134
5.00R12(*)	3.50	305	568	134
6.00R9	4.00	229	540	160
6.00R14C	4.50	356	626	158
6.00R16(*)	4.50	406	728	170
6.50R10	5.00	254	588	177
6.50R14C	5.00	356	640	170
6.50R16(*)	4.50	406	742	176
6.50R20(*)	5.00	508	860	181
7.00R12	5.00	305	672	192
7.00R14C	5.00	356	650	180
7.00R15(*)	5.00	381	746	197
7.00R16C	5.50	406	778	198
7.00R16	5.50	406	784	198
7.00R20	5.50	508	892	198
7.50R10	5.50	254	645	207
7.50R14C	5.50	356	686	195
7.50R15(*)	6.00	381	772	212
7.50R16(*)	6.00	406	802	210
7.50R17(*)	6.00	432	852	210
8.25R15	6.50	381	836	230
8.25R16	6.50	406	860	230
9.00R15	6.00	381	840	249
9.00R16(*)	6.50	406	912	246

(*) The tyre size designation may be supplemented with the letter "C".

Table B
Tyres for light commercial vehicles

<i>Tyre size designation</i>	<i>Measuring rim width code</i>	<i>Nominal rim diameter d (mm)</i>	<i>Outer diameter D (mm)</i>	<i>Section width S (mm)</i>
<i>Metric designated</i>				
145 R 10 C	4.00	254	492	147
145 R 12 C	4.00	305	542	147
145 R 13 C	4.00	330	566	147
145 R 14 C	4.00	356	590	147
145 R 15 C	4.00	381	616	147
155 R 12 C	4.50	305	550	157
155 R 13 C	4.50	330	578	157
155 R 14 C	4.50	356	604	157
165 R 13 C	4.50	330	596	167
165 R 14 C	4.50	356	622	167
165 R 15 C	4.50	381	646	167
175 R 13 C	5.00	330	608	178
175 R 14 C	5.00	356	634	178
175 R 16 C	5.00	406	684	178
185 R 13 C	5.50	330	624	188
185 R 14 C	5.50	356	650	188
185 R 15 C	5.50	381	674	188
185 R 16 C	5.50	406	700	188
195 R 14 C	5.50	356	666	198
195 R 15 C	5.50	381	690	198
195 R 16 C	5.50	406	716	198
205 R 14 C	6.00	356	686	208
205 R 15 C	6.00	381	710	208
205 R 16 C	6.00	406	736	208
215 R 14 C	6.00	356	700	218
215 R 15 C	6.00	381	724	218
215 R 16 C	6.00	406	750	218
245 R 16 C	7.00	406	798	248
17 R 15 C	5.00	381	678	178
17 R 380 C	5.00	381	678	178
17 R 400 C	150 mm	400	698	186
19 R 400 C	150 mm	400	728	200
<i>Code designated</i>				
5.60 R 12 C	4.00	305	570	150
6.40 R 13 C	5.00	330	648	172
6.70 R 13 C	5.00	330	660	180
6.70 R 14 C	5.00	356	688	180
6.70 R 15 C	5.00	381	712	180

Table C
Tyres for special applications

<i>Tyre size designation</i>	<i>Measuring rim width code</i>	<i>Nominal rim diameter d (mm)</i>	<i>Outer diameter D (mm)</i>	<i>Section width S (mm)</i>
<i>Code designated</i>				
15x4 1/2R8	3.25	203	385	122
16x6R8	4.33	203	425	152
18x7	4.33	203	462	173
18x7R8	4.33	203	462	173
21x8R9	6.00	229	535	200
21x4	2.32	330	565	113
22x4 1/2	3.11	330	595	132
23x5	3.75	330	635	155
23x9R10	6.50	254	595	225
25x6	3.75	330	680	170
27x10R12	8.00	305	690	255
28x9R15	7.00	381	707	216
<i>Metric designated</i>				
200R15	6.50	381	730	205
250R15	7.50	381	735	250
300R15	8.00	381	840	300

Table D
Tyres with LT designation

Tolerances shown at the bottom of the tables apply in place of those shown in paragraphs 3.21.1.4.2.2.2. and 3.21.1.3.2.

Outer diameters are listed for the various categories of use: Normal, Snow, and Special.

Tyre size designation	Measuring rim width code	Nominal rim diameter d(mm)	Outer diameter D (mm) ¹		Section width S (mm) ²
			Normal	Snow	
6.00R16LT	4.50	406	732	743	173
6.50R16LT	4.50	406	755	767	182
6.70R16LT	5.00	406	722	733	191
7.00R13LT	5.00	330	647	658	187
7.00R14LT	5.00	356	670	681	187
7.00R15LT	5.50	381	752	763	202
7.00R16LT	5.50	406	778	788	202
7.10R15LT	5.00	381	738	749	199
7.50R15LT	6.00	381	782	794	220
7.50R16LT	6.00	406	808	819	220
8.25R16LT	6.50	406	859	869	241
9.00R16LT	6.50	406	890	903	257
G78R15LT	6.00	381	711	722	212
H78R15LT	6.00	381	727	739	222
L78R15LT	6.50	381	749	760	236
L78R16LT	6.50	406	775	786	236
7R14.5LT ³	6.00	368	677		185
8R14.5LT ³	6.00	368	707		203
9R14.5LT ³	7.00	368	711		241
7R17.5LT	5.25	445	758	769	189
8R17.5LT	5.25	445	788	799	199

¹ Coefficient "b" for the calculation of Dmax: 1.08.

² Overall width may exceed this value up to +8 per cent.

³ The suffix "MH" may replace "LT" in the tyre size designation (e.g. 7R14.5 MH) where MH stands for Mobile Home.

Table E
High flotation LT tyres

Comment [JN105]: UNECE Reg. 54 supplement 20.
Ref. ECE/TRANS/WP29/2015/66.

Tyre-size designation ¹	Measuring rim width code	Nominal rim diameter d (mm)	Outer diameter D (mm) ²		Section width S (mm) ³
			Normal	Snow	
9R15LT	8.00	381	744	755	254
10R15LT	8.00	381	773	783	264
11R15LT	8.00	381	777	788	279
24x7.50R13LT	6.00	330	597	604	191
27x8.50R14LT	7.00	356	674	680	218
28x8.50R15LT	7.00	381	699	705	218
29x9.50R15LT	7.50	381	724	731	240
30x9.50R15LT	7.50	381	750	756	240
31x10.50R15LT	8.50	381	775	781	268
31x11.50R15LT	9.00	381	775	781	290
31x12.50R15LT	10.00	381	775	781	318
31x13.50R15LT	11.00	381	775	781	345
31x15.50R15LT	12.00	381	775	781	390
32x11.50R15LT	9.00	381	801	807	290
33x9.50 R15LT	7.50	381	826	832	240
33x10.50R15LT	8.50	381	826	832	268
33x10.50R17LT	8.50	432	826	832	268
33x10.50R18LT	8.50	457	826	832	268
33x11.50R18LT	9.00	457	826	832	290
33x12.50R15LT	10.00	381	826	832	318
33x12.50R17LT	10.00	432	826	832	318
33x12.50R18LT	10.00	457	826	832	318
33x12.50R20LT	10.00	508	826	832	318
33x12.50R22LT	10.00	559	826	832	318
33x13.50R15LT	11.00	381	826	832	345
33x15.50R15LT	12.00	381	826	832	390
34x10.50R17LT	8.50	432	851	858	268
34x12.50R18LT	10.00	457	851	858	318
35x12.50R15LT	10.00	381	877	883	318
35x12.50R17LT	10.00	432	877	883	318
35x12.50R18LT	10.00	457	877	883	318
35x12.50R20LT	10.00	508	877	883	318

Tyre-size designation ¹	Measuring rim width code	Nominal rim diameter d (mm)	Outer diameter D (mm) ²		Section width S (mm) ³
			Normal	Snow	
35x12.50R22LT	10.00	559	877	883	318
35x13.50R15LT	11.00	381	877	883	345
35x13.50R18LT	11.00	457	877	883	345
35x13.50R20LT	11.00	508	877	883	345
35x14.50R15LT	12.00	381	877	883	372
36x13.50R18LT	11.00	457	902	908	345
36x14.50R15LT	12.00	381	902	908	372
36x14.50R17LT	12.00	432	902	908	372
36x14.50R18LT	12.00	457	902	908	372
36x15.50R15LT	12.00	381	902	908	390
37x12.50R15LT	10.00	381	928	934	318
37x12.50 R17LT	10.00	432	928	934	318
37x12.50R18LT	10.00	457	928	934	318
37x12.50R20LT	10.00	508	928	934	318
37x12.50R22LT	10.00	559	928	934	318
37x13.50R15LT	11.00	381	928	934	345
37x13.50R17LT	11.00	432	928	934	345
37x13.50R18LT	11.00	457	928	934	345
37x13.50R20LT	11.00	508	928	934	345
37x13.50R22LT	11.00	559	928	934	345
37x13.50R24LT	11.00	610	928	934	345
37x14.50R15LT	12.00	381	928	934	372
38x13.50R17LT	11.00	432	953	959	345
38x13.50R20LT	11.00	508	953	959	345
38x13.50R24LT	11.00	610	953	959	345
38x14.50R17LT	12.00	432	953	959	372
38x14.50R18LT	12.00	457	953	959	372
38x14.50R20LT	12.00	508	953	959	372
38x15.50R15LT	12.00	381	953	959	390
38x15.50R17LT	12.00	432	953	959	390
38x15.50R18LT	12.00	457	953	959	390
38x15.50R20LT	12.00	508	953	959	390
39x13.50R17LT	11.00	432	978	985	345
40x13.50R17LT	11.00	432	1004	1010	345
40x13.50R20LT	11.00	508	1004	1010	345
40x14.50R17LT	12.00	432	1004	1010	372
40x14.50R18LT	12.00	457	1004	1010	372
40x14.50R20LT	12.00	508	1004	1010	372
40x15.50R20LT	12.00	508	1004	1010	390
40x15.50R22LT	12.00	559	1004	1010	390

<i>Tyre-size designation I</i>	<i>Measuring rim width code</i>	<i>Nominal rim diameter d (mm)</i>	<i>Outer diameter D (mm)²</i>		<i>Section width S (mm)³</i>
			<i>Normal</i>	<i>Snow</i>	
40x15.50R24LT	12.00	610	1004	1010	390
42x14.50R17LT	12.00	432	1055	1061	372
42x14.50R20LT	12.00	508	1055	1061	372
8.00R16.5LT	6.00	419	720	730	203
8.75R16.5LT	6.75	419	748	759	222
9.50R16.5LT	6.75	419	776	787	241
10R16.5LT	8.25	419	762	773	264
12R16.5LT	9.75	419	818	831	307
30x9.50R16.5LT	7.50	419	750	761	240
31x10.50R16.5LT	8.25	419	775	787	266
33x12.50R16.5LT	9.75	419	826	838	315
35x12.50 R16.5LT	10.00	419	877	883	318
37x12.50R16.5LT	9.75	419	928	939	315
37x14.50R16.5LT	11.25	419	928	939	365

Annex 8

Comment [JN106]: Agreement given during GRRF 80th session to delete all annexes with test report.

Test report – Rolling sound emissions for tyres

Part 1 – Report

Name of testing organization:

Name and address of applicant:

Test report No.:

Manufacturer and brand name or trade description:

Tyre Class (C1 or C2 or C3):

Category of use:

Sound level according to paragraphs 3.8.6.4. and 3.8.6.5. of this regulation: dB(A)
at reference speed of 70/80 km/h¹

Comments (if any):

Date:

Signature:

Part 2 – Test data

Date of test:

Test vehicle (Make, model, year, modifications, etc.):

Test vehicle wheelbase: mm

Location of test track:

Date of track certification to ISO 10844: ~~1994~~2014:

Issued by:

Method of certification:

Tyre test details:

Tyre size designation:

Tyre service description:

Reference inflation pressure:

Comment [JN107]:
Supplement 4 to the 02 series of amendments- Date of entry into force: 13 February 2014
WP.29/2013/55

And

Proposal for Supplement 8 to the 02 series of amendments to Regulation No. 117 (Tyre rolling resistance, rolling noise and wet grip)
ECE/TRANS/WP.29/2015/65

¹ Strike out what does not apply.

Test data

	<i>Front-left</i>	<i>Front-right</i>	<i>Rear-left</i>	<i>Rear-right</i>
Test mass (kg)				
Tyre load index (%)				
Inflation pressure (cold) (kPa)				

Test rim width code:

Temperature measurement sensor type:

Valid test results:

<i>Run No.</i>	<i>Test speed km/h</i>	<i>Direction of run</i>	<i>Sound level left² measured dB(A)</i>	<i>Sound level right² measured dB(A)</i>	<i>Air temp. °C</i>	<i>Track temp. °C</i>	<i>Sound level left² temp. corrected dB(A)</i>	<i>Sound level right² temp. corrected dB(A)</i>	<i>Comments</i>
1									
2									
3									
4									
5									
6									
7									
8									

Formatted: Strikethrough

Regression line slope:

Sound level after temperature correction according to paragraph 3.8.6.3:dB(A)

² Relative to the vehicle.

Comment [JN108]: Agreement given during GRRF 80th session to delete all annexes with test report.

Annex 9

Test reports examples of wet grip index

Example 1: Test report of wet grip index using trailer method

Test report number:

Test date:

Type of road surface:

Texture depth (mm):

μ -peak (SRTT14 E1136):

or-BPN:

Speed (km/h):

Water depth (mm):

Comment [AR109]: Revision 2 – Amendment 1 Supplement 1 to the 02 series of amendments - Date of entry into force: 18 November 2012 WP.29/2012/2 amended by para 65 of ECE/TRANS/WP.29/1095

No.	1	2	3	4	5	6	7	8	9	10
Size										
Service description										
Tyre identification										
Rim										
Pattern										
Load (N)										
Pressure (kPa)										
μpeak	1									
	2									
	3									
	4									
	5									
	6									
	7									
	8									
Average										
Standard deviation σ										
(σ/average) \leq 5 per cent										
Ra, Adjusted										
Wet grip index										
Surface temp. (°C)										
Ambient temp. (°C)										
Remarks										

Example 2: Test report of wet grip index using passenger car method

Driver:

Test date:

Track:
Texture depth (mm):
BPN:
Water depth (mm):

Passenger car:
Brand:
Model:
Type

Initial speed (km/h):
Final speed (km/h):

No.	1	2	3	4	5					
Brand	Uniroyal	TYRE B	TYRE C	TYRE D	Uniroyal					
Pattern	ASTM F 2493 SRTT16	PATTERN B	PATTERN C	PATTERN D	ASTM F 2493 SRTT16					
Size	P225/60R16	SIZE B	SIZE C	SIZE D	P225/60R16					
Service description	97S	LISS	LISS	LISS	97S					
Tyre identification	XXXXXXXXX	YYYYYYYYY	ZZZZZZZZL	NNNNNNNNN	XXXXXXXXX					
Rim										
Front axle pressure (kPa)										
Rear axle pressure (kPa)										
Front axle load (kg)										
Rear axle load (kg)										
Wet surface temp (°C)										
Ambient temp (°C)										
	Braking distance (m)	Average deceleration (m/s ²)	Braking distance (m)	Average deceleration (m/s ²)	Braking distance (m)	Average deceleration (m/s ²)	Braking distance (m)	Average deceleration (m/s ²)	Braking distance (m)	Average deceleration (m/s ²)
Measurement	1									
	2									
	3									
	4									
	5									
	6									
	7									
	8									
	9									
	10									
Average AD (m/s ²)										
Standard deviation (m/s ²)										
Validation of results Coeff. of variation (per cent) < 3 per cent										
Adjusted average AD of ref. tyre: R _a (m/s ²)										
BFC(R) reference tyre (SRTT16)										
BFC(T) candidate tyre										
Wet grip index (%)										

Comment [AR110]: Revision 2 – Amendment 1
Supplement 1 to the 02 series of amendments - Date of entry into force: 18 November 2012
WP.29/2012/2 amended by para 65 of ECE/TRANS/WP.29/1095

Formatted: Strikethrough

Test report - Adhesion on wet surface

Part 1 — Report

Name of testing organization:

Name and address of applicant:

Test report No.:

Manufacturer and brand name or trade description:

Tyre Class (C1):

Category of use:

Adhesion coefficient on wet surfaces relative to SRTT according to paragraphs 3.12.3.1.2.15. or 3.12.3.2.2.14.:

Comments (if any):

Date:

Signature:

Part 2 Test data

Date of test:

Test vehicle (make, model, year, modifications, etc. or trailer identification):

Location of test track:

Test track characteristics:

Issued by:

Method of certification:

Test tyre details:

Tyre size designation and service description:

Tyre brand and trade description:

Reference inflation pressure: kPa

Test data:

<i>Tyre</i>	<i>SRTT</i>	<i>Candidate</i>	<i>Control</i>
Test tyre load (kg)			
Water depth (mm) (from 0.5 to 1.5 mm)			
Wetted track temperature average (°C) (from 5 to 35 °C)			

Test rim width code:

Temperature measurement sensor type:

Identification of the SRTT:[†]

Valid test results:

[†] SRTT: Standard Reference Test Tyre.

ECE/TRANS/180/Add.16
Annex 9

<i>Run No:</i>	<i>Test speed (km/h)</i>	<i>Direction of run</i>	<i>SRTT²</i>	<i>Candidate tyre</i>	<i>Control tyre</i>	<i>Peak brake force coefficient (pbfc)</i>	<i>Mean fully developed deceleration (mfdd)</i>	<i>Wet Grip index (G)</i>	<i>Comments</i>
1									
2									
3									
4									
5									
6									
7									
8									

Annex 7

Tyre standards organizations

The Tire and Rim Association, Inc. (TRA)

The European Tyre and Rim Technical Organisation (ETRTO)

The Japan Automobile Tyre Manufacturers' Association (JATMA)

The Tyre and Rim Association of Australia (TRAA)

South Africa Bureau of Standards (SABS)

China Association for Standardization (CAS)

Indian Tyre Technical Advisory Committee (ITTAC)

International Standards Organization (ISO)

Annex 8

Rolling resistance test equipment tolerances

1. Purpose

The limits specified in this annex are necessary in order to achieve suitable levels of repeatable test results, which can also be correlated among various test laboratories. These tolerances are not meant to represent a complete set of engineering specifications for test equipment; rather, they should serve as guidelines for achieving reliable test results.

2. Test rims

2.1. Width

For passenger car tyre rims (C1 tyres), the test rim width shall be the same as the measuring rim determined in ISO 4000-1: 2010 clause 6.2.2.

For truck and bus tyres (C2 and C3), the rim width shall be the same as the measuring rim determined in ISO 4209-1:2001, clause 5.1.3.

In cases where the width is not defined in the above mentioned ISO Standards, the rim width as defined by one of the standards organizations as specified in Annex 7 may be used.

2.2. Run-out

Run-out shall meet the following criteria:

- (a) Maximum radial run-out: 0.5 mm;
- (b) Maximum lateral run-out: 0.5 mm.

3. Drum / tyre alignment

General:

Angle deviations are critical to the test results.

3.1. Load application

The direction of tyre loading application shall be kept normal to the test surface and shall pass through the wheel centre within

- (a) 1 mrad for the force and deceleration methods;
- (b) 5 mrad for the torque and power methods.

3.2. Tyre alignment

3.2.1. Camber angle

The plane of the wheel shall be perpendicular to the test surface within 2 mrad for all methods.

3.2.2. Slip angle

The plane of the tyre shall be parallel to the direction of the test surface motion within 1 mrad for all methods.

Comment [AR111]: Revision 2 - Amendment 2
Supplement 2 to the 02 series of amendments – Date of entry into force: 15 July 2013
WP.29/2012/55

4. Control accuracy

Test conditions shall be maintained at their specified values, independent of perturbations induced by the tyre and rim non-uniformity, such that the overall variability of the rolling resistance measurement is minimized. In order to meet this requirement, the average value of measurements taken during the rolling resistance data collection period shall be within the accuracies stated as follows:

- (a) Tyre loading:
 - (i) For $LI \leq 121 \pm 20$ N or ± 0.5 per cent, whichever is greater;
 - (ii) For $LI > 121 \pm 45$ N or ± 0.5 per cent whichever is greater;
- (b) Cold inflation pressure: ± 3 kPa;
- (c) Surface speed:
 - (i) ± 0.2 km/h for the power, torque and deceleration methods;
 - (ii) ± 0.5 km/h for the force method;
- (d) Time:
 - (i) ± 0.02 s for the time increments specified in paragraph 3.22.4.5.(b) for the data acquisition in the deceleration method in $\Delta\omega/\Delta t$ form;
 - (ii) ± 0.2 per cent for the time increments specified in paragraph 3.22.4.5.(a) for the data acquisition in the deceleration method in $d\omega/dt$ form;
 - (iii) ± 5 per cent for the other time durations specified in paragraph 3.22.

5. Instrumentation accuracy

The instrumentation used for readout and recording of test data shall be accurate within the tolerances stated below:

Parameter	Load Index ≤ 121	Load Index > 121
Tyre load	± 10 N or ± 0.5 % ^(a)	± 30 N or ± 0.5 % ^(a)
Inflation pressure	± 1 kPa	± 1.5 kPa
Spindle force	± 0.5 N or ± 0.5 % ^(a)	± 1.0 N or ± 0.5 % ^(a)
Torque input	± 0.5 Nm or ± 0.5 % ^(a)	± 1.0 Nm or ± 0.5 % ^(a)
Distance	± 1 mm	± 1 mm
Electrical power	± 10 W	± 20 W
Temperature	± 0.2 °C	
Surface speed	± 0.1 km/h	
Time	± 0.01 s - ± 0.1 % - ± 10 s ^(b)	
Angular velocity	± 0.1 %	

^(a) Whichever is greater.

Comment [AR112]: Revision 2 – Amendment 1
Supplement 1 to the 02 series of amendments - Date of entry into force: 18 November 2012
WP.29/2012/6

- (b) ± 0.01 s for the time increments specified in paragraph 3.22.4.5.(b) for the data acquisition in the deceleration method in $\Delta\omega/\Delta t$ form
 ± 0.1 per cent for the time increments specified in paragraph 3.22.4.5.(a) for the data acquisition in the deceleration method in $d\omega/dt$ form
 ± 10 sec for the other time durations specified in paragraph 3.22.

~~The instrumentation used for readout and recording of test data shall be accurate within the tolerances stated below:~~

Parameter	Load Index ≤ 121	Load Index > 121
Tyre load	± 10 N or $\pm 0.5\%$ ^(a)	± 30 N or $\pm 0.5\%$ ^(a)
Inflation pressure	± 1 kPa	± 1.5 kPa
Spindle force	± 0.5 N or $\pm 0.5\%$ (a)	± 1.0 N or $\pm 0.5\%$ (a)
Torque input	± 0.5 Nm or $\pm 0.5\%$ (a)	± 1.0 Nm or $\pm 0.5\%$ (a)
Distance	± 1 mm	± 1 mm
Electrical power	± 10 W	± 20 W
Temperature	± 0.2 °C	
Surface speed	± 0.1 km/h	
Time	± 0.01 s	
Angular velocity	$\pm 0.1\%$	

Comment [AR113]: Proposal for Supplement 8 to the 02 series of amendments to Regulation No. 117 (Tyre rolling resistance, rolling noise and wet grip)
ECE/TRANS/WP.29/2015/65

Comment [AR114]: Revision 2 - Amendment 2
Supplement 2 to the 02 series of amendments – Date of entry into force: 15 July 2013

^(a) ~~Whichever is greater.~~

6. Compensation for load/spindle force interaction and load misalignment for the force method only

Compensation of both load/spindle force interaction ("cross talk") and load misalignment may be achieved either by recording the spindle force for both forward and reverse tyre rotation or by dynamic machine calibration. If spindle force is recorded for forward and reverse directions (at each test condition), compensation is achieved by subtracting the "reverse" value from the "forward" value and dividing the result by two. If dynamic machine calibration is intended, the compensation terms may be easily incorporated in the data reduction.

In cases where reverse tyre rotation immediately follows the completion of the forward tyre rotation, a warm-up time for reverse tyre rotation shall be at least 10 minutes for Class C1 tyres and 30 minutes for all other tyre types.

7. Test surface roughness

The roughness, measured laterally, of the smooth steel drum surface shall have a maximum centreline average height value of $6.3 \mu\text{m}$.

Note: In cases where a textured drum surface is used instead of a smooth steel surface, this fact is noted in the test report. The surface texture shall then be 180 μm deep (80 grit) and the laboratory is responsible for maintaining the surface roughness characteristics. No specific correction factor is

Comment [AR115]: Proposal for Supplement 7 to the 02 series of amendments to Regulation No. 117
WP.29/2015/5

recommended for cases where a textured drum surface is used.

Annex 9

Measuring rim width

1. Class C1 tyres

The measuring rim width R_m is equal to the product of the nominal section width S_N and the coefficient K_2 :

$$R_m = K_2 \times S_N$$

rounded to the nearest standardized rim, where K_2 is the rim/section width ratio coefficient. For tyres mounted on 5° drop-centre rims with a nominal diameter expressed by a two-figure code:

$K_2 = 0.7$ for nominal aspect ratios 95 to 75

$K_2 = 0.75$ for nominal aspect ratios 70 to 60

$K_2 = 0.8$ for nominal aspect ratios 55 and 50

$K_2 = 0.85$ for nominal aspect ratio 45

$K_2 = 0.9$ for nominal aspect ratios 40 to 30

$K_2 = 0.92$ for nominal aspect ratios 20 and 25

2. Class C2 and C3 tyres

The measuring rim width R_m is equal to the product of the nominal section width S_N and the coefficient K_4 :

$R_m = K_4 \times S_N$ rounded to the nearest standardized rim width.

Table 1
Coefficients for determining measuring rim width

<i>Tyre Structure Code</i>	<i>Type of rim</i>	<i>Nominal aspect ratio H/S</i>	<i>Measuring rim/ section ratio K_4</i>
B, D, R	5° tapered	100 to 75	0.70
		70 and 65	0.75
		60	0.75
		55	0.80
		50	0.80
		45	0.85
		40	0.90
	15° tapered (drop-centre)	90 to 65	0.75
		60	0.80
		55	0.80
		50	0.80
		45	0.85
		40	0.85

Note: Other factors may be established for new tyre concepts (structures).

Annex 13

Comment [JN116]: Agreement given during GRRF 80th session to delete all annexes with test report.

Test report and test data – Rolling resistance for tyres

Part 1: Report

1. **Testing organization:**
2. **Name and address of applicant:**
3. **Test report No.:**
4. **Manufacturer and brand name or trade description:**
5. **Tyre class (C1, C2 or C3):**
6. **Category of use:**
7. **Rolling resistance coefficient (temperature and drum diameter corrected):**
8. **Comments (if any):**
9. **Date:**
10. **Signature:**

Comment [JN117]: Type Approval authority or Technical Service has been deleted to be certification neutral

Part 2: Test data

1. **Date of test:**
2. **Test machine identification and drum diameter/surface:**
3. **Test tyre details:**
- 3.1. **Tyre size designation and service description:**
- 3.2. **Tyre brand and trade description:**
- 3.3. **Reference inflation pressure:** **kPa**
4. **Test data:**
- 4.1. **Measurement method:**
- 4.2. **Test speed:** **km/h**
- 4.3. **Load:** **N**
- 4.4. **Test inflation pressure, initial:**
- 4.5. **Distance from the tyre axis to the drum outer surface under steady state conditions, r_L :** **m**
- 4.6. **Test rim width and material:**
- 4.7. **Ambient temperature:** **°C**
- 4.8. **Skim test load (except deceleration method):** **N**
5. **Rolling resistance coefficient:**
- 5.1. **Initial value (or average in the case of more than 1):** **N/kN**
- 5.2. **Temperature corrected N/kN:**

~~5.3. Temperature and drum diameter corrected: N/k~~
~~N~~

Annex 10

Deceleration method: Measurements and data processing for deceleration value obtaining in differential form $d\omega/dt$.

1. Record dependency "distance-time" of rotating body decelerated from peripheral with a speed range such as 82 to 78 km/h or 62 to 58 km/h dependent on tyre class (Paragraph 3.22.4.2., table 1) in a discrete form (figure 1) for a rotating body:

$$z=f(t_z)$$

where:

z is a number of body revolutions during deceleration;
 t_z is end time of revolution number z in seconds recorded with 6 digits after zero.

Figure 1

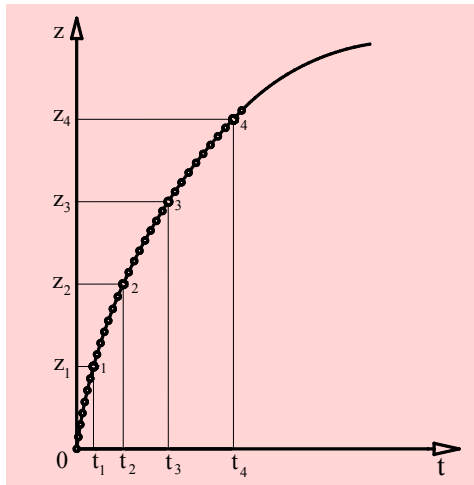

Note 1: The lower speed of the recording range may be reduced down to 60 km/h when test speed is 80 km/h and 40 km/h when the test speed is 60 km/h.

2. Approximate recorded dependency by continuous, monotonic, differentiable function:
 - 2.1. Choose the value nearest to the maximum of z dividable by 4 and divide it into 4 equal parts with bounds: $0, z_1(t_1), z_2(t_2), z_3(t_3), z_4(t_4)$.
 - 2.2. Work out the system for 4 equations each of the form:

$$z_m = A \ln \frac{\cos B(T_z - t_m)}{\cos B T_z}$$

where unknowns:

A is a dimensionless constant,
B is a constant in revolutions per second,
 T_z is a constant in seconds,
m is the number of bounds shown in figure 1.

Insert in these 4 equations the coordinates of 4-th bound above.

- 2.3. Take constants A, B and T_z as the solution of the equation system of paragraph 2.2. above using iteration process and approximate measured data by formulae:

$$z(t) = A \ln \frac{\cos B(T_z - t)}{\cos B T_z}$$

where:

$z(t)$ is the current continuous angular distance in number of revolutions (not only integer values);
t is time in seconds.

Note 2: Other approximating functions $z = f(t_z)$ may be used if their adequacy is proven.

3. Calculate the deceleration j in revolutions per second squared (s^{-2}) by the formula:

$$j = AB^2 + \frac{\omega^2}{A}$$

where:

ω is the angular speed in revolutions per second (s^{-1}).
For the case $U_n = 80$ km/h; $\omega = 22.222/R_r$ (or R).
For the case $U_n = 60$ km/h; $\omega = 16.666/R_r$ (or R).

4. Estimate the quality of approximation of measured data and its accuracy by parameters:

- 4.1. Standard deviation in percentages:

$$\sigma = \sqrt{\frac{1}{n-1} \sum_1^n \left[1 - \frac{z(t)}{z} \right]^2} \times 100\%$$

- 4.2. Coefficient of determination

$$R^2 = 1 - \frac{\sum_1^n [z - z(t)]^2}{\sum_1^n [z - \bar{z}]^2}$$

where:

$$\bar{z} = \frac{1}{n} \sum_{z=1}^n z = \frac{1}{n} (1 + 2 + \dots + n) = \frac{1+n}{2}$$

Note 3: The above calculations for this variant of the deceleration method for tyre rolling resistance measurement can be executed by the

Formatted: French (Belgium)

computer program "Deceleration Calculator" downloadable from the WP.29 website¹ as well as any software which allows the calculation of nonlinear regression.

Comment [AR118]: Proposal for Supplement 7 to the 02 series of amendments to Regulation No. 117 WP.29/2015/5

¹ To be indicated at a later stage.

Annex 15

Test reports and test data for C1 and C2 tyres¹¹ – Snow test

Part 1 – Report

1. **Testing organization:**
2. **Name and address of applicant:**
3. **Test report No.:**
4. **Manufacturer and brand name or trade description:**
5. **Tyre class:**
6. **Category of use:**
7. **Snow index relative to SRTT according to paragraph 3.23.1.1.**
 - 7.1. **Test procedure and SRTT used**
8. **Comments (if any):**
9. **Date:**
10. **Signature:**

Part 2 – Test data

1. **Date of test:**
2. **Location of test track:**
- 2.1. **Test track characteristics:**

	<i>At start of tests</i>	<i>At end of tests</i>	<i>Specification</i>
Weather			
Ambient temperature			-2 °C to 15 °C
Snow temperature			-4 °C to 15 °C
CTI index			75 to 85
Other			

3. **Test vehicle (make, model and type, year):**
4. **Test tyre details**
- 4.1. **Tyre size designation and service description:**
- 4.2. **Tyre brand and trade description:**
- 4.3. **Test tyre data:**

Comment [JN119]: Agreement given during GRRF 80th session to delete all annexes with test report.

Comment [AR120]: Revision 2 - Amendment 2
Supplement 2 to the 02 series of amendments – Date of entry into force: 15 July 2013
WP.29/2012/54

Comment [JN121]: Type Approval authority or Technical Service has been deleted to be certification neutral

Comment [AR122]: Revision 3 - Corrigendum 1
Corrigendum 4 to 02 series of amendments – Date of entry into force: 12 March 2014

Comment [AR123]: Revision 2 - Amendment 2
Supplement 2 to the 02 series of amendments – Date of entry into force: 15 July 2013
WP.29/2012/54

	<i>SRTT_(1st-test)</i>	<i>Candidate</i>	<i>Candidate</i>	<i>SRTT_(2nd-test)</i>
Tyre dimensions				
Test rim width code				
Tyre loads F/R (kg)				
Load index F/R (per cent)				
Tyre pressure F/R (kPa)				

5. —

Test results: mean fully developed decelerations (m/s²) / traction coefficient¹.

<i>Run number</i>	<i>Specification</i>	<i>SRTT_(1st-test)</i>	<i>Candidate</i>	<i>Candidate</i>	<i>SRTT_(2nd-test)</i>
1					
2					
3					
4					
5					
6					
Mean					
Std deviation					
CV (%)	<6 %				
Validation SRTT	(SRTT) < 5 %				
SRTT average					
Snow index		100			

¹ Strike out what does not apply.

Annex 16

Test reports and test data for C3 tyres – Snow test.

Part 1 – Report

1. **Testing organization:**
2. **Name and address of applicant:**
3. **Test report No.:**
4. **Manufacturer and brand name or trade description:**
5. **Tyre class:**
6. **Category of use:**
7. **Snow index relative to SRTT according to paragraph 3.23.1.1.**
- 7.1. **Test procedure and SRTT used**
8. **Comments (if any):**
9. **Date:**
10. **Signature:**

Part 2 – Test data

1. **Date of test:**
2. **Location of test track:**
- 2.1. **Test track characteristics:**

	<i>At start of tests</i>	<i>At end of tests</i>	<i>specification</i>
Weather			
Ambient temperature			-2 °C to -15 °C
Snow temperature			-4 °C to -15 °C
CTI index			80 to 90
Other			

3. **Test vehicle (make, model and type, year):**
4. **Test tyre details**
- 4.1. **Tyre size designation and service description:**
- 4.2. **Tyre brand and trade description:**
- 4.3. **Test tyre data:**

	<i>SRTT (1st test)</i>	<i>Candidate 1</i>	<i>Candidate 2</i>	<i>Candidate 3</i>	<i>SRTT (2nd test)</i>
Tyre dimensions					
Test rim width code					

Comment [JN124]: Agreement given during GRRF 80th session to delete all annexes with test report.

Comment [JN125]: Type Approval authority or Technical Service has been deleted to be certification neutral

Tyre loads F/R (kg)					
Load index F/R (per cent)					
Tyre pressure F/R (kPa)					

5. — Test results: average accelerations (m/s²)

Run number	Specification	SRTT (1st test)	Candidate 1	Candidate 2	Candidate 3	SRTT (2nd test)
1						
2						
3						
4						
5						
6						
Mean						
Std deviation						
Slip ratio (per cent)						
CV (per cent)	≤ 6 per cent					
Validation SRTT	(SRTT) ≤ 6 per cent	X	X	X	X	
SRTT average		X	X	X	X	X
Snow index		1.00				X