



Economic and Social Council

Distr.: General
2 September 2016

Original: English

Economic Commission for Europe

Inland Transport Committee

World Forum for Harmonization of Vehicle Regulations

170th session

Geneva, 15-18 November 2016

Item 4.8.8 of the provisional agenda

1958 Agreement :

Consideration of draft amendments

to existing Regulations submitted by GRSP

Proposal for Supplement 5 to Regulation No. 129 (Enhanced Child Restraint Systems)

Submitted by the Working Party on Passive Safety *

The text reproduced below was adopted by the Working Party on Passive Safety (GRSP) at its fifty-ninth session (ECE/TRANS/WP.29/GRSP/59, para. 41). It is based on GRSP-59-03-Rev.1 as reproduced by Annex V to the report and ECE/TRANS/WP.29/GRSP/2016/5 as amended by Annex V to report. It is submitted to the World Forum for Harmonization of Vehicle Regulations (WP.29) and to the Administrative Committee AC.1 for consideration.

* In accordance with the programme of work of the Inland Transport Committee for 2016–2017 (ECE/TRANS/254, para. 159 and ECE/TRANS/2016/28/Add.1, cluster 3.1), the World Forum will develop, harmonize and update Regulations in order to enhance the performance of vehicles. The present document is submitted in conformity with that mandate.

Supplement 5 to Regulation No. 129 (Enhanced Child Restraint Systems (ECRS))

Table of content, insert the reference to new Annex 23, to read:

"23 Flammability of materials intended to be used in built-in child restraint systems"

Text of the Regulation,

Paragraphs 6.3.1.1. and 6.3.1.2., amend to read

"6.3.1.1. The Child Restraint System manufacturer shall declare in writing that the toxicity of materials used in the manufacture of restraint systems and accessible to the restrained child is in conformity with the relevant parts of EN 71-3:2013+A1:2014 (paragraph 4.2., Table 2, Category III for specific requirements and paragraph 7.3.3. for test methodology). Tests confirming the validity of the declaration may be carried out at the discretion of the Technical Service.

6.3.1.2. The flammability of Child Restraint Systems submitted for approval shall be assessed by one of the following methods:

Method 1 is applicable only to non-built-in Child Restraint Systems and Method 2 is applicable only to vehicle specific built-in Child Restraint Systems.

Method 1

The Child Restraint System manufacturer shall declare in writing that the flammability of materials used to manufacture the Child Restraint System is in conformity with the method of section 5.4 of EN 71-2:2011+A1:2014 with a maximum rate of spread of flame of 30 mm/s. Tests confirming the validity of the declaration may be carried out at the discretion of the Technical Service. Where fabrics are assembled together, these shall be tested as a composite.

"Composite material" means a material composed of several layers of similar or different materials intimately held together at their surfaces by cementing, bonding, cladding, welding, etc. In such a case, the material shall be tested as a composite. When different materials are connected together intermittently, such materials shall not be considered as composite materials and therefore tested separately.

Tests confirming the validity of the declaration may be carried out at the discretion of the Technical Service.

Method 2

The applicant shall declare in writing that when testing materials in accordance with Annex 23 of this regulation, the materials used shall not burn, nor transmit a flame front across its surface, at a rate of more than 100 mm per minute. Each material used in a child restraint system shall conform to these requirements. However, the requirement concerning transmission of a flame front shall not apply to a surface created by cutting a test specimen for purposes of testing pursuant to Annex 23.

The requirements shall be met in both the "in-use" and in the "stowed" positions of the built-in Child Restraint System.

If a material stops burning before it has burned for 60 seconds from the start of timing, and has not burned more than 51 mm from the point where the timing was started, it shall be considered to meet the burn-rate requirement specified above.

Tests confirming the validity of the declaration may be carried out at the discretion of the Technical Service."

Paragraph 6.6.3.1., amend to read:

"6.6.3.1. The Enhanced Child Restraint System shall be tested as prescribed in paragraph 7.1.2. of this Regulation; at no point during the whole test shall the manikin be fully ejected from the device. In addition when the test bench is in the upside down position, the dummy's head shall not move more than 300 mm from its original position in a vertical direction relative to the test bench; this measurement shall be performed after the load has been removed."

Paragraph 7.1.2.3., amend to read:

"7.1.2.3. At this static inverted position a mass equivalent to four times that of the dummy, with a tolerance of -0/+5 per cent with reference to dummies nominal masses as in Annex 8, shall be applied vertically downwards in a plane perpendicular to the axis of rotation in addition to the dummy utilizing the load application device described in Annex 21. The load shall be applied in a gradual controlled manner at a rate not exceeding gravitational acceleration or 400 mm/min. Maintain the prescribed maximum load for a duration of 30 -0/+5 seconds."

Paragraph 7.1.3.1.1.5.1., amend to read:

"7.1.3.1.1.5.1. Deceleration test device:

The deceleration of the trolley shall be achieved by using the apparatus prescribed in Annex 6 to this Regulation or any other device giving equivalent results. This apparatus shall be capable of the performance specified in paragraph 7.1.3.4. and hereafter specified:

For frontal impact, the trolley shall be so propelled that, at the beginning of the test, its velocity is 50 ± 2 km/h and its acceleration curve is within the hatched area of the graph in Annex 7, Appendix 1.

For rear impact, the trolley shall be so propelled that, at the beginning of the test, its velocity is 30 ± 2 km/h and its acceleration curve is within the hatched area of the graph in Annex 7, Appendix 2.

Tests performed at a higher speed and/or with an acceleration that exceeds the upper boundary of the hatched area shall be considered satisfactory if the child restraint system meets the performance requirements for the test.

Tests performed at a lower acceleration shall be considered satisfactory only if the acceleration curve crosses the lower boundary of the hatched area for a cumulative period of up to 3 ms.

In fulfilling the above requirements, the Technical Service shall use a mass of trolley (equipped with its seat), as specified in paragraph 1. of Annex 6, greater than 380 kg."

Paragraphs 7.3. to 7.3.3., amend to read:

"7.3. Certification of test bench cushion

- 7.3.1. The test bench cushion shall be certified when new to establish initial values for impact peak deceleration, and then after every 50 dynamic tests or at least every month, whichever is the sooner.
- 7.3.2. The certification and measuring procedures shall correspond to those specified in the latest version of ISO 6487; the measuring equipment shall correspond to the specification of a data channel with a channel filter class (CFC) 60.
- Using the test device defined in Annex 14 to this Regulation, conduct three tests on the bench base prepared as described in Annex 6, foam covered with textile, 150 ± 5 mm from the front edge of the cushion on the centre line and at 150 ± 5 mm in each direction from the centre line.
- Place the bench cushion on a flat rigid surface. Place the device vertically above the test point, at a height of 500 ± 5 mm and allow it to fall freely to make impact on the seat surface. Record the deceleration curve.
- 7.3.3. The initial peak recorded values for impact deceleration shall be 24 ± 4 g and subsequent peak values recorded shall not deviate by more than 15 percent from the initial values."

Paragraph 8.1., amend to read:

- "8.1. The test report shall record the results of all tests and measurements including the following test data:
- (a) The type of device used for the test (acceleration or deceleration device);
 - (b) The total velocity change;
 - (c) The trolley speed immediately before impact only for deceleration sleds;
 - (d) The acceleration or deceleration curve during all the velocity change of the trolley and at least 300 ms;
 - (e) The time (in ms) when the head of the manikin reaches its maximum displacement during the performance of the dynamic test;
 - (f) The place occupied by the buckle during the tests, if it can be varied, and
 - (g) The name and address of the laboratory where tests have been performed;
 - (h) And any failure or breakage;
 - (i) The following dummy criteria: HPC, Head acceleration Cum3 ms, Upper neck tension force, Upper neck moment, Chest acceleration Cum3 ms Chest deflection Abdominal Pressure (in frontal impact)."

Annex 21, amend to read:

"Annex 21

...

Load application device II

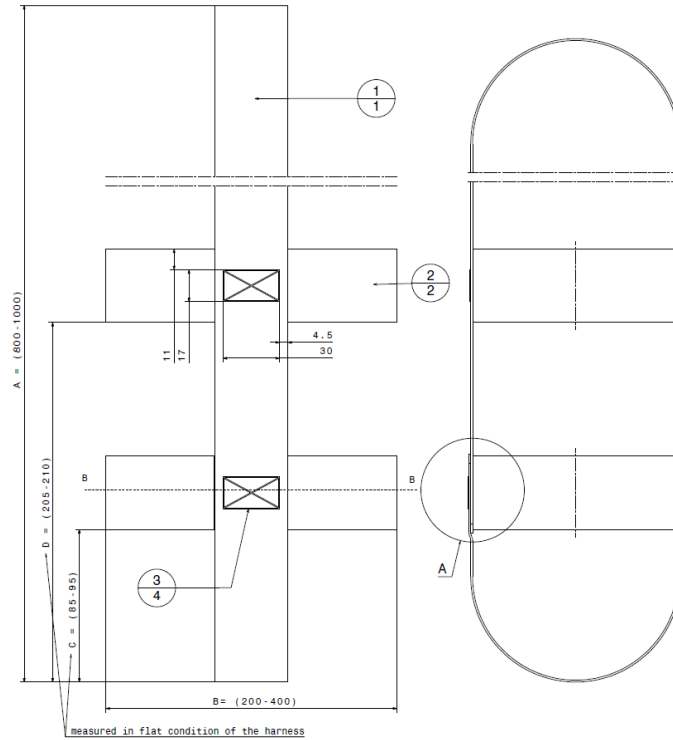

..."

Insert a new Annex 23, to read:

"Annex 23

Flammability of materials intended to be used in built-in child restraint systems

1. Definitions

"Occupant compartment air space" means the space within the occupant compartment that normally contains refreshable air.
2. Material selection (see Figure 1 below)
 - 2.1. Any portion of a single or composite material which is within 13 mm of the occupant compartment air space shall meet the requirements in paragraph 6.1.6.
 - 2.1.1. Any material that does not adhere to other material(s) at every point of contact shall meet the requirements of paragraph 6.1.6. when tested separately

2.1.2. Any material that adheres to other materials at every point of contact shall meet the requirements of paragraph 6.1.6. when tested as a composite with the other material(s).

Material A has a non-adhering interface with material B and is tested separately.

Part of material B is within 13 mm of the occupant compartment air space, and materials B and C adhere at every point of contact; therefore, B and C are tested as a composite.

The cut is in material C as shown in Figure 1, to make a specimen 13 mm thick.

Figure 1

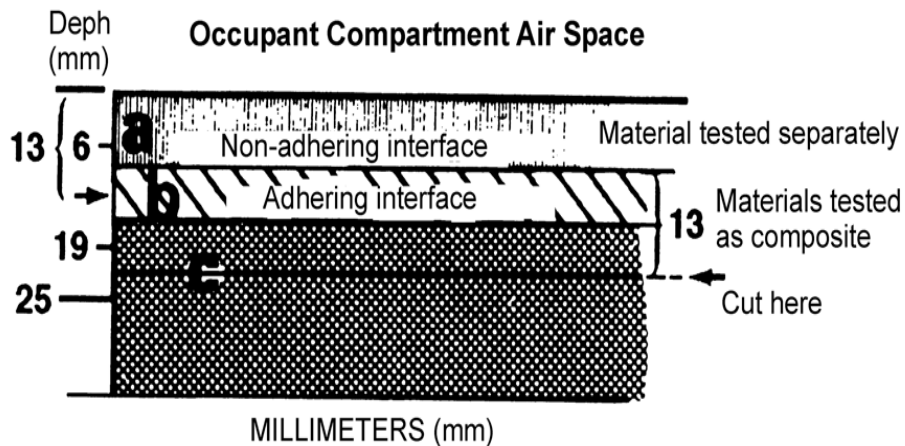

3. Test procedure

3.1. The test is conducted in a metal cabinet for protecting the test specimens from drafts. The interior of the cabinet is 381 mm long, 203 mm deep, and 356 mm high. It has a glass observation window in the front, a closable opening to permit insertion of the specimen holder, and a hole to accommodate tubing for a gas burner. For ventilation, it has a 13 mm clearance space around the top of the cabinet, ten holes in the base of the cabinet, each hole 19 mm in diameter and legs to elevate the bottom of the cabinet by 10 mm, all located as shown in Figure 2.

3.2. Prior to testing, each specimen is conditioned for 24 hours at a temperature of 21° C, and a relative humidity of 50 per cent, and the test is conducted under those ambient conditions.

3.3. The test specimen is inserted between two matching U-shaped frames of metal stock 25 mm wide and 10 mm high.

The interior dimensions of the U-shaped frames are 51 mm wide by 330 mm long.

A specimen that softens and bends at the flaming end so as to cause erratic burning is kept horizontal by supports consisting of thin, heat-resistant wires, spanning the width of the U-shaped frame under the specimen at 25 mm intervals.

A device that may be used for supporting this type of material is an additional U-shaped frame, wider than the U-shaped frame containing the specimen, spanned by 10-mil wires of heat-resistant composition at 25 mm intervals, inserted over the bottom U-shaped frame.

- 3.4. A bunsen burner with a tube of 10 mm inside diameter is used.
The gas adjusting valve is set to provide a flame, with the tube vertical, of 38 mm in height. The air inlet to the burner is closed.
- 3.5. The gas supplied to the burner has a flame temperature equivalent to that of natural gas.
4. Preparation of specimens
 - 4.1. Each specimen of material to be tested shall be a rectangle 102 mm wide by 356 mm long, wherever possible.
The thickness of the specimen is that of the single or composite material used in the vehicle, except that if the material's thickness exceeds 13 mm, the specimen is cut down to that thickness measured from the surface of the specimen closest to the occupant compartment air space.
Where it is not possible to obtain a flat specimen because of surface curvature, the specimen is cut to not more than 13 mm in thickness at any point.
The maximum available length or width of a specimen is used where either dimension is less than 356 mm or 102 mm.
 - 4.2. The specimen is produced by cutting the material in longitudinal as well as transvers direction.
The specimen is oriented so that the surface closest to the occupant compartment air space faces downward on the test frame.
 - 4.3. Material with a napped or tufted surface is placed on a flat surface and combed twice against the nap with a comb having seven to eight smooth, rounded teeth per 25 mm.
5. Test
 - 5.1. Mount the specimen so that both sides and one end are held by the U-shaped frame, and specimen is not more than 51 mm, so that the sides of the specimen cannot be held in the U-shaped frame, place the specimen in position on wire supports as described in 2.3, with one end held by the closed end of the U-shaped frame.
 - 5.2. Place the mounted specimen in a horizontal position, in the center of the cabinet.
 - 5.3. With the flame adjusted according to 2.4, position the bunsen burner and specimen so that the center of the burner tip is 19 mm below the center of the bottom edge of the open end of the specimen.
 - 5.4. Expose the specimen to the flame for 15 seconds.
 - 5.5. Begin timing (without reference to the period of application of the burner flame) when the flame from the burning specimen reaches a point 38 mm from the open end of the specimen.

5.6. Measure the time that it takes the flame to progress to a point 38 mm from the clamped end of the specimen. If the flame does not reach the specified end point, time its progress to the point where flaming stops.

5.7. Calculate the burn rate from the formula:

$$B = 60 \times (D/T)$$

Where:

B = Burn rate in millimeters per minute

D = Length the flame travels in millimeters, and

T = Time in seconds for the flame to travel D millimeters.

Figure 2

All dimensions in millimeters (mm)

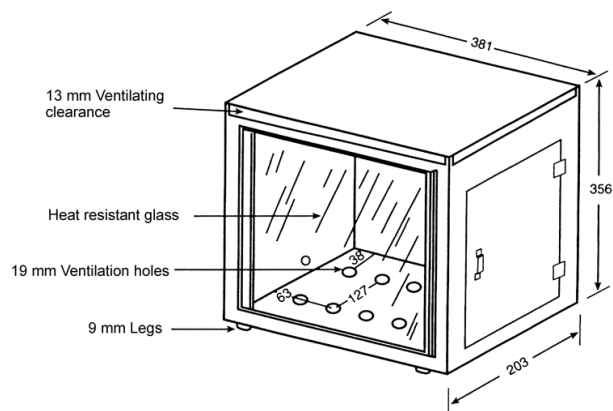

11