

Analysis of the use of the Oblique Bar in the “C” Signs

By: Adel Alyousifi

Presented to:

Group of Experts on Road Signs and Signals
Eighth Session

Geneva, 1st and 2nd September 2016



This sign is the oldest Traffic sign known to mankind, it goes as far as 700 BC (Assyrian Empire).

The meaning of the sign (King's road, No one allowed to Stop).

Introduction

Traffic signs are the tools that a contracting party uses to get messages across to the drivers. The messages are consists and composed of four elements: shapes, symbols, colors and words (SSCW). To create a traffic sign, * we should follow three steps, first; analyzing the Situation in a given section of the road, to identify the **reasons** for creating the traffic sign, and the safety messages that we want to get across to drivers so they pass the section safely. These safety messages could be prohibitions, warnings, restrictions, regulations or an information. Second; it is very important for a better standardization and creating a good sign is to **write down** these safety messages. Finally **translate** the written safety messages into a sign using the four elements mentioned earlier (SSCW).

*

Creating a Traffic Sign is not one person job.

A good sign is a result of a collective ideas, perceptions and opinions of several experts.

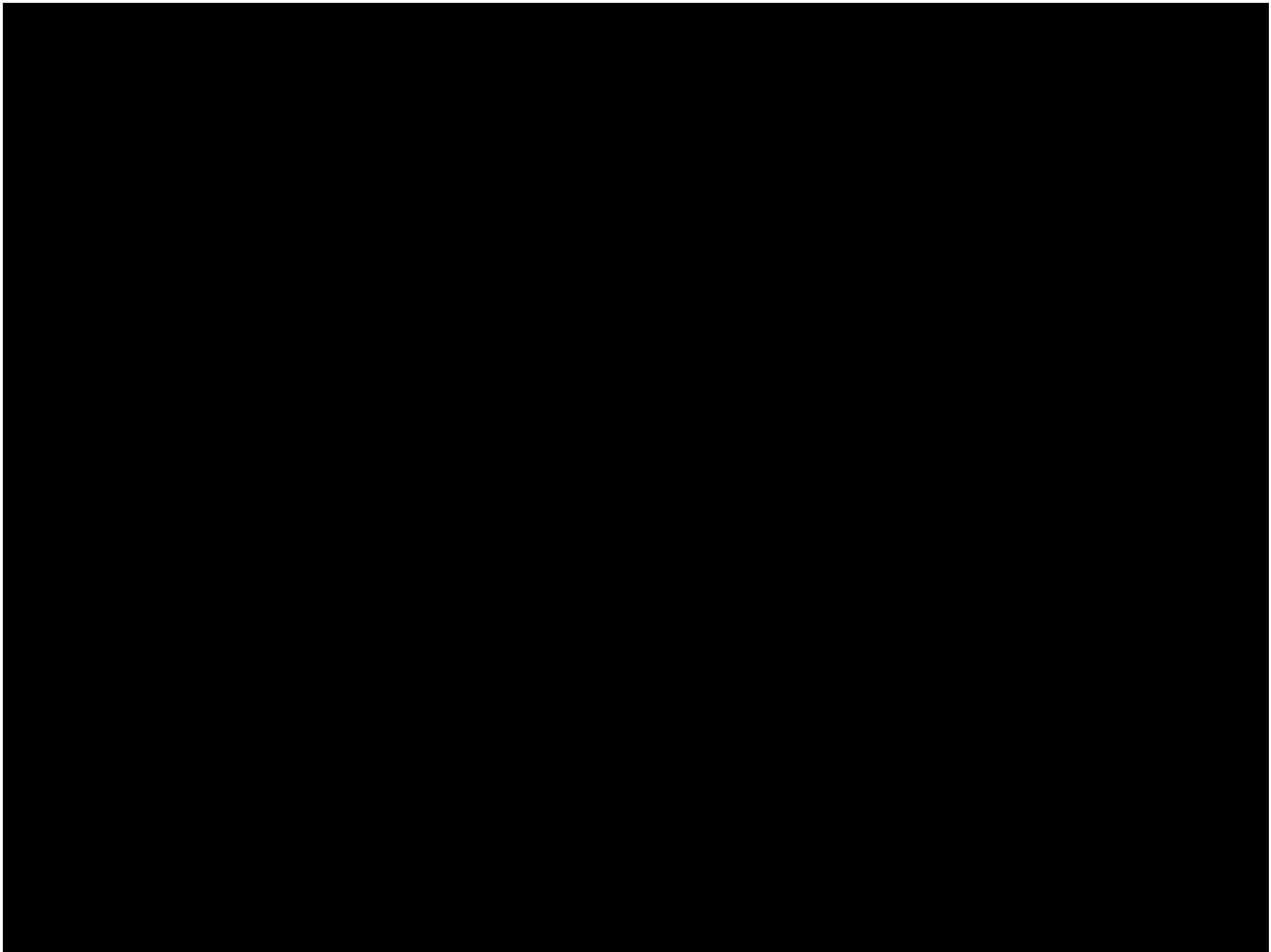

Example on how to create a traffic sign.

A truck or a car get trapped on railway track, and we want to design a sign to strongly order the driver to break the gate barrier immediately and without hesitation once he or she is trapped to avoid a deadly accident with a train.

First of the three steps to create a traffic sign; is the **reasons**, this require analyzing and identifying the hazards in the situation.

A trapped vehicle on railway track and a train is approaching it, which will result in a deadly accident.

Second step; is **writing down** the required safety message for the driver.

If you are trapped on the railway track, break the barrier immediately without hesitation to avoid a deadly crash with a train.

Third step; is **translating** the safety message into a traffic sign using the four elements, Shapes, Symbols, Color and Words (**SSCW**).

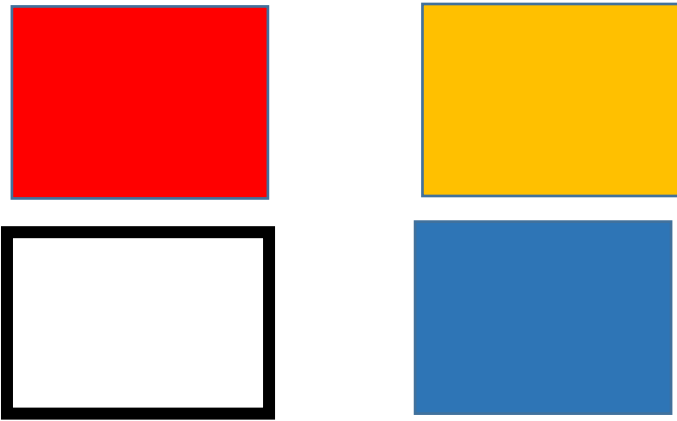
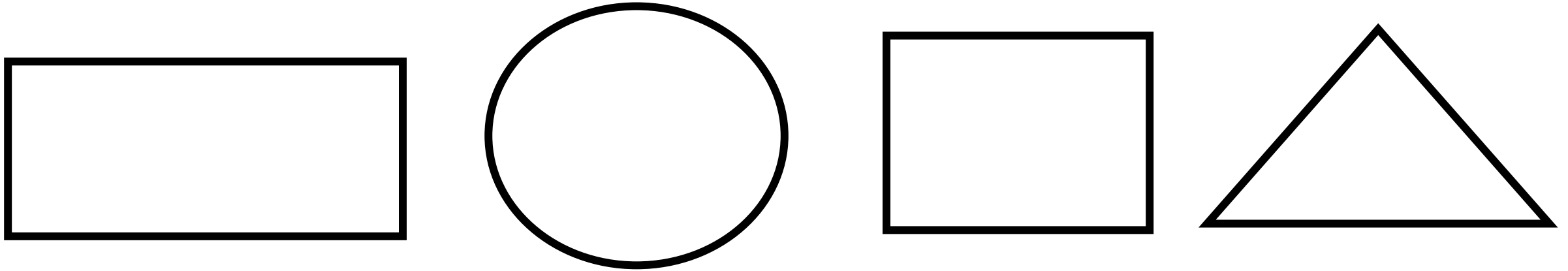

**BREAK IT
IF TRAPPED**



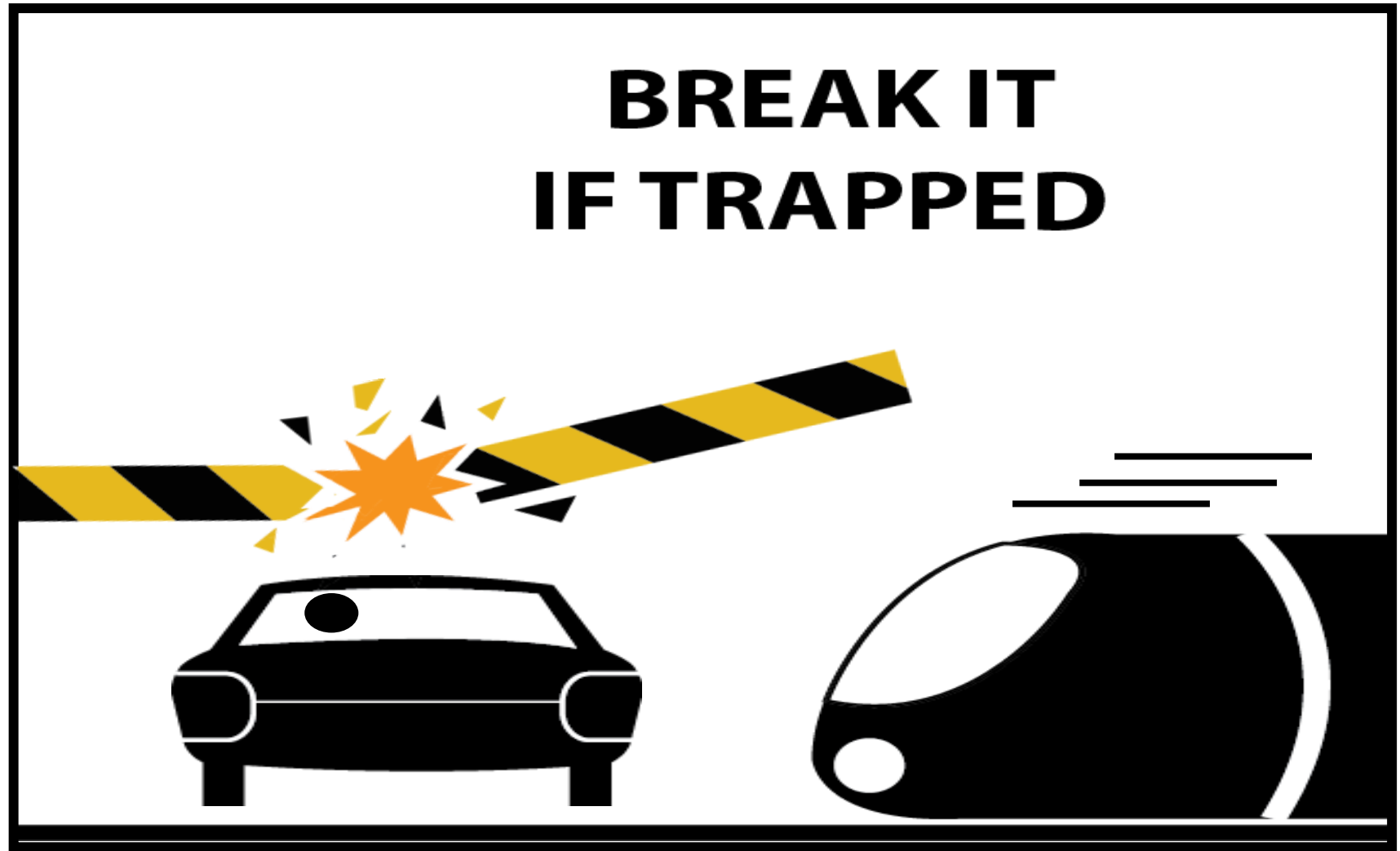

A good sign will reflect the exact meaning of the safety message.

If you are trapped on the railway track, break the barrier immediately without hesitation to avoid a deadly crash with a train.

BREAK IT IF TRAPPED



Sign placement

Eye Bird
View

**BREAK IT
IF TRAPPED**

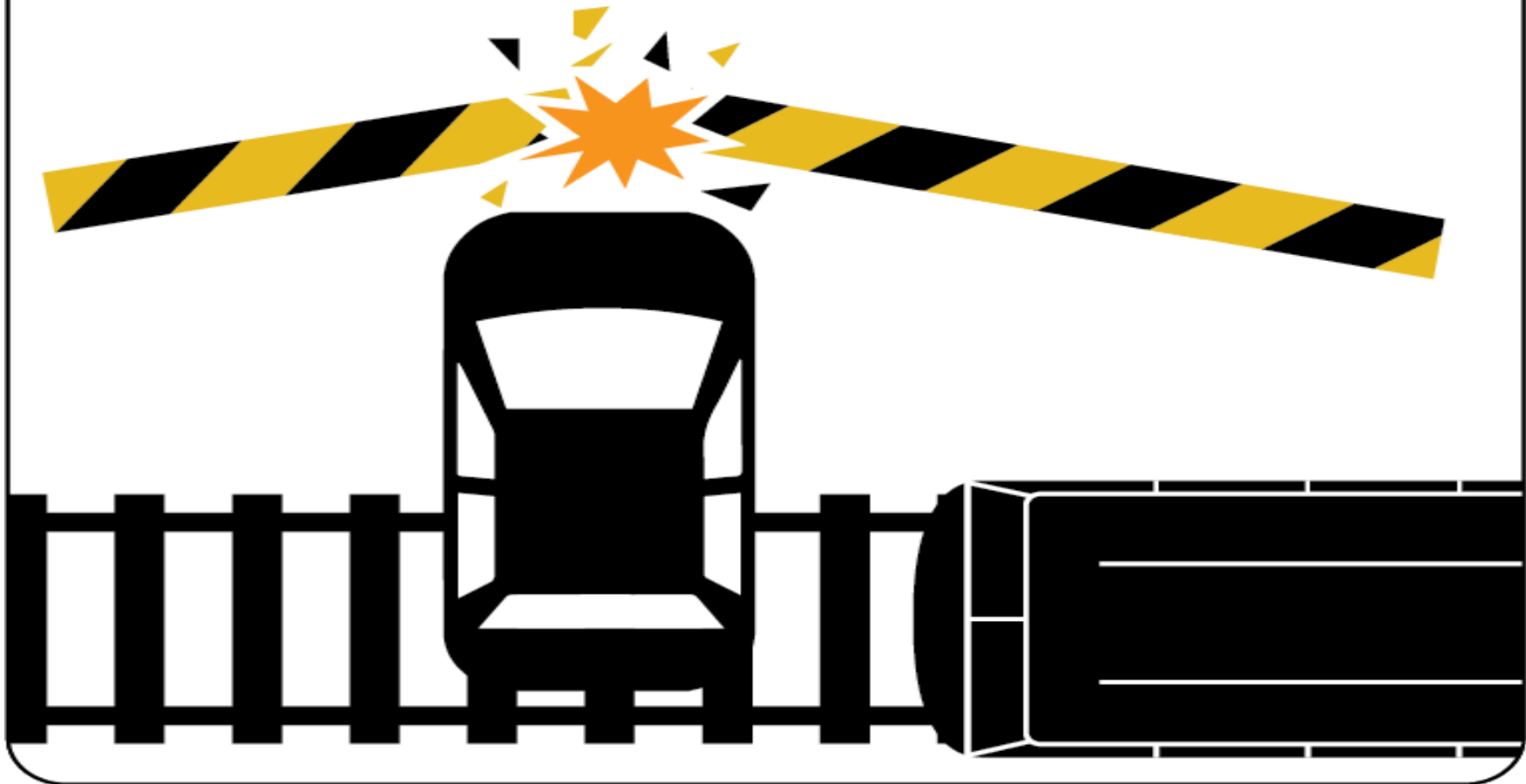

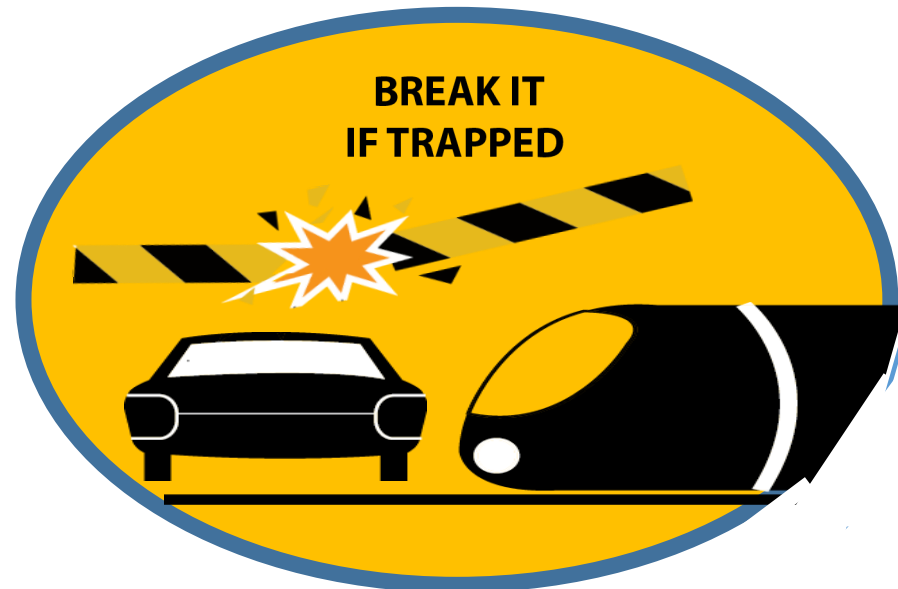
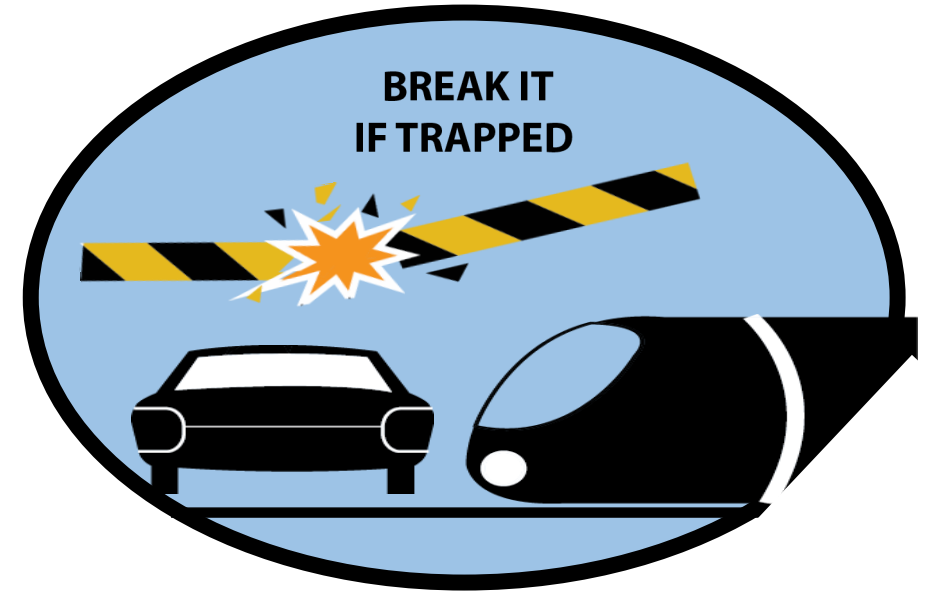
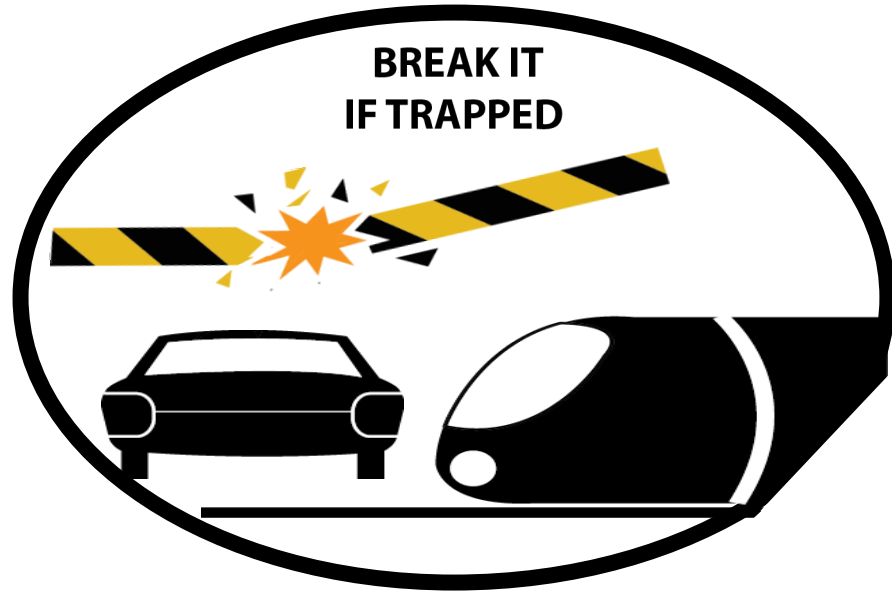

Different Shape
and Colors.

Also to check if any existing traffic sign is good or not, and does it give the exact meaning of the messages which it was designed for? We also should adapt the three steps of designing a traffic sign. First; we should know the situation and the reasons in which the sign was created for. Second; read the written safety messages (if it was written) related to that situation*, finally match the sign and its elements to see if they convey the exact meaning of the written safety messages.

Now let us adopt this method to signs C, 17.

*

One of the most important fact in VC is that the safety messages for almost all the signs are missing, which makes it very difficult to really judge the design of any sign if its good or not, in other words: how can we tell if a sign is good or not, if we do not know what safety messages it was designed for and what meaning it should give?

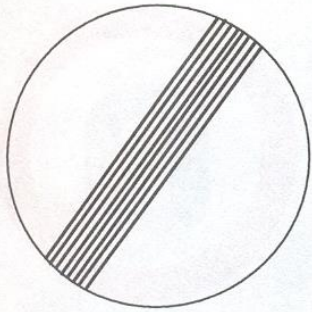

C, 17^a

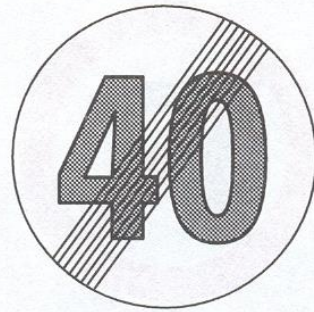

C, 17^b

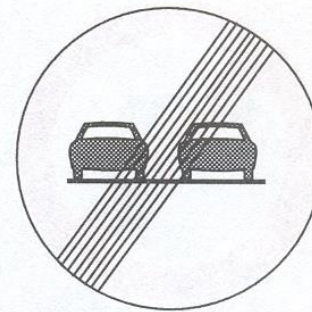

C, 17^c

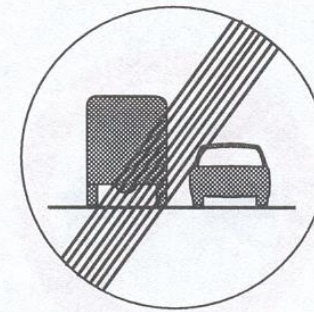

C, 17^d

8. End of prohibition or restriction

(a) The point at which all prohibitions notified by prohibitory signs for moving vehicles cease to apply shall be indicated by sign C, 17^a "END OF ALL LOCAL PROHIBITIONS IMPOSED ON MOVING VEHICLES". This sign shall be circular and have a white or yellow ground; it shall have no border or only a black rim, and shall bear a diagonal band, sloping downward from right to left, which may be black or dark grey or consist of black or grey parallel lines.

(b) The point at which a particular prohibition or restriction notified to moving vehicles by a prohibitory or restrictive sign ceases to apply shall be indicated by sign C, 17^b "END OF SPEED LIMIT" or sign C, 17^c "END OF PROHIBITION OF OVERTAKING", OR SIGN C, 17^d "END OF PROHIBITION OF OVERTAKING FOR GOODS VEHICLES". These signs shall be similar to sign C, 17^a, but shall show, in addition, in light grey the symbol of the prohibition or restriction which has ceased.

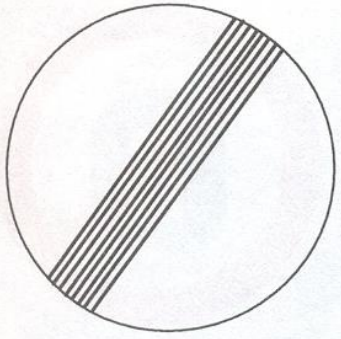

C, 17^a

8. End of prohibition or restriction

(a) The point at which all prohibitions notified by prohibitory signs for moving vehicles cease to apply shall be indicated by sign C, 17^a "END OF ALL LOCAL PROHIBITIONS IMPOSED ON MOVING VEHICLES". This sign shall be circular and have a white or yellow ground; it shall have no border or only a black rim, and shall bear a diagonal band, sloping downward from right to left, which may be black or dark grey or consist of black or grey parallel lines.

VC defines the C, 17a signs as "The point at which all prohibitions notified by prohibitory signs for moving vehicles cease to apply shall be indicated by sign C, 17a. Then summarize the definition by saying it is "End of all local prohibitions imposed on moving vehicles".

I personally have difficulty understanding what the word "Local" in the definition means (Distant Radius), second why the definition insist on "Moving vehicles"? There are some prohibitions signs that apply to moving and stationed vehicles like C, 15 (prohibition of the use of audible devices). Third, does the words "All prohibitions" means ending some general prohibitions on all roads like the use of hand held mobile or allowing children on front seats or even driving without a seat belt on?

Now let us look at one situation on the road that probably the C, 17a sign was designed for.

Military Base

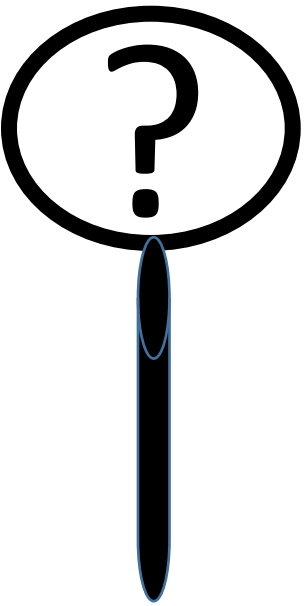
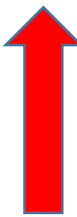

Creating a Sign to End all five Prohibitions.



Hospital

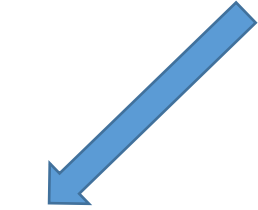
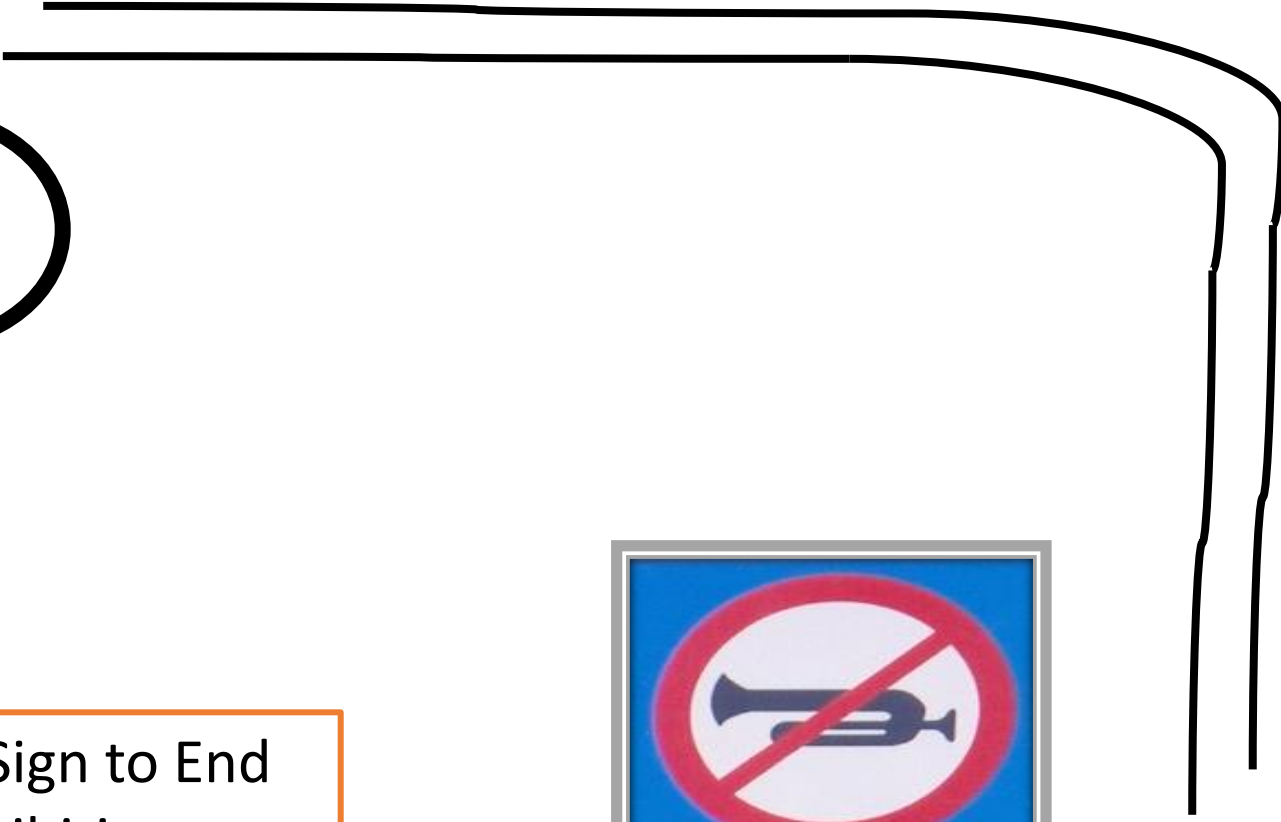



Imaginary safety Message

Dear drivers, Local prohibitions which previously were imposed , now cease to apply, please drive safely.

What Prohibitions?

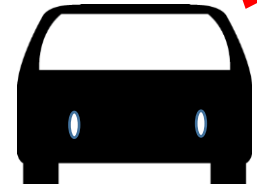

(1) It is hard to remember all the prohibitions previously notified.

(2) Sign (C, 17 a) is an **Abstract** sign, and it needs to be memorized for its meanings.



Military Base

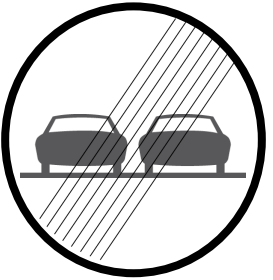
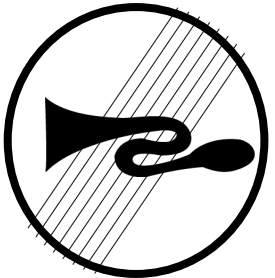
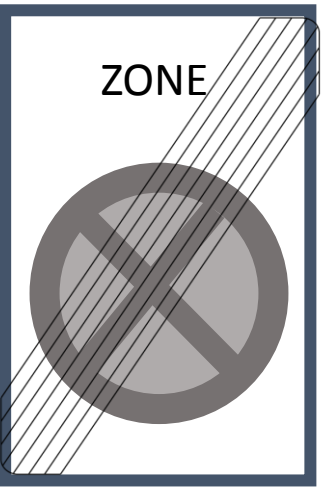
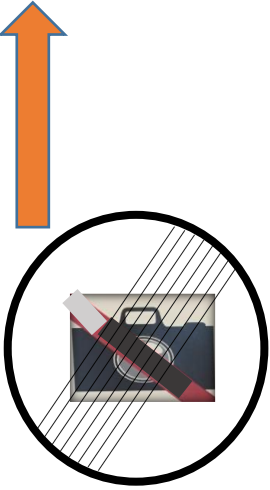

Why not ending each prohibition separately when its cease to apply?

Hospital

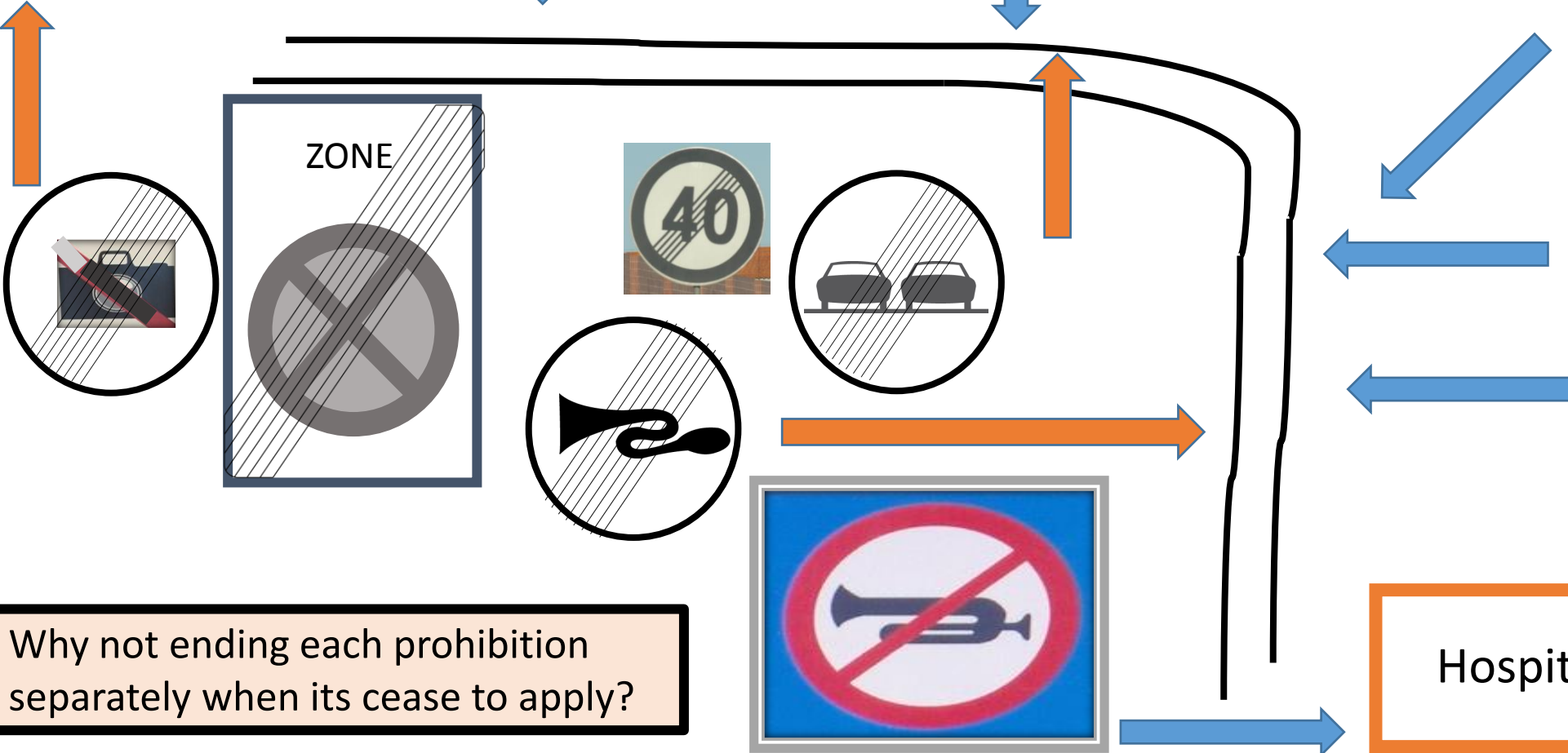

VC allows sign C, 17a to have a Band or a Parallel Lines. In this case:

The two signs should have different **numbers** and different codes for the **base color**

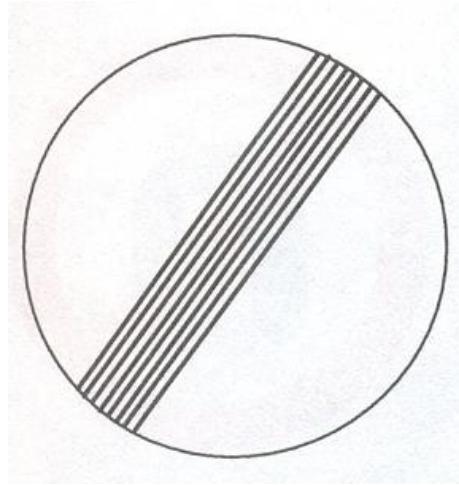

C, 17a, W

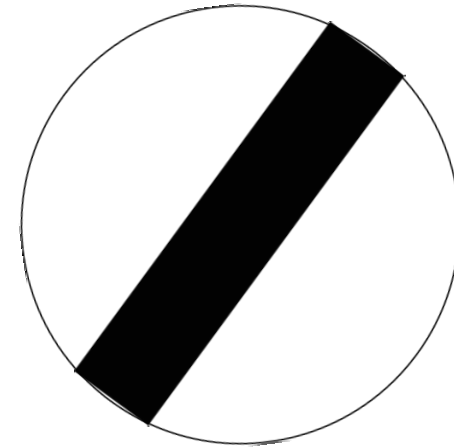

C, 17 ab, Y

Article 5, Paragraph 2 In VC

2. Where this Convention allows a choice between several signs or several symbols,
 - (a) Contracting Parties undertake to adopt only one of such signs or symbols for the whole of their territories;

Adopting the **Band** will result in **loosing** some or most of the **symbols**.

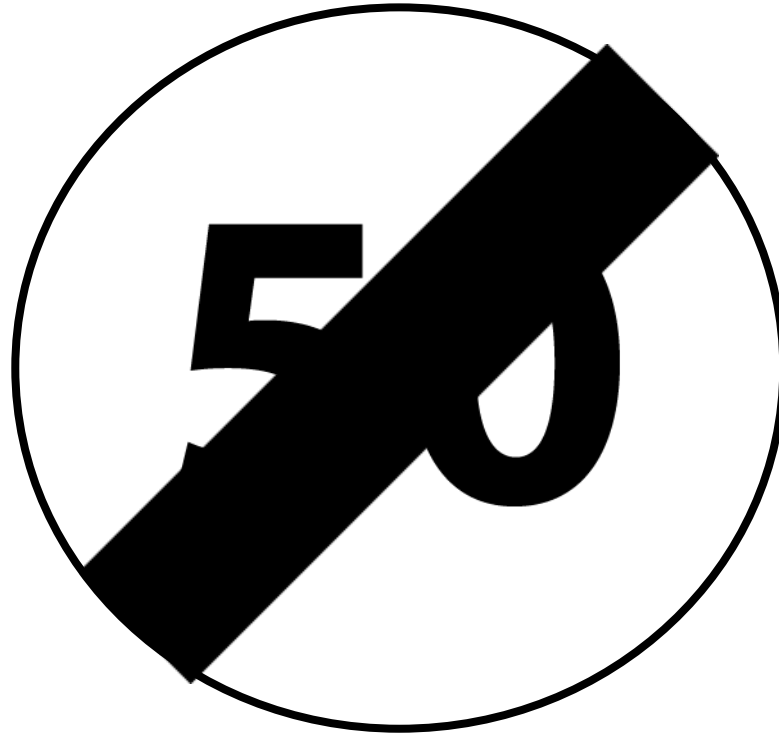



Turkey

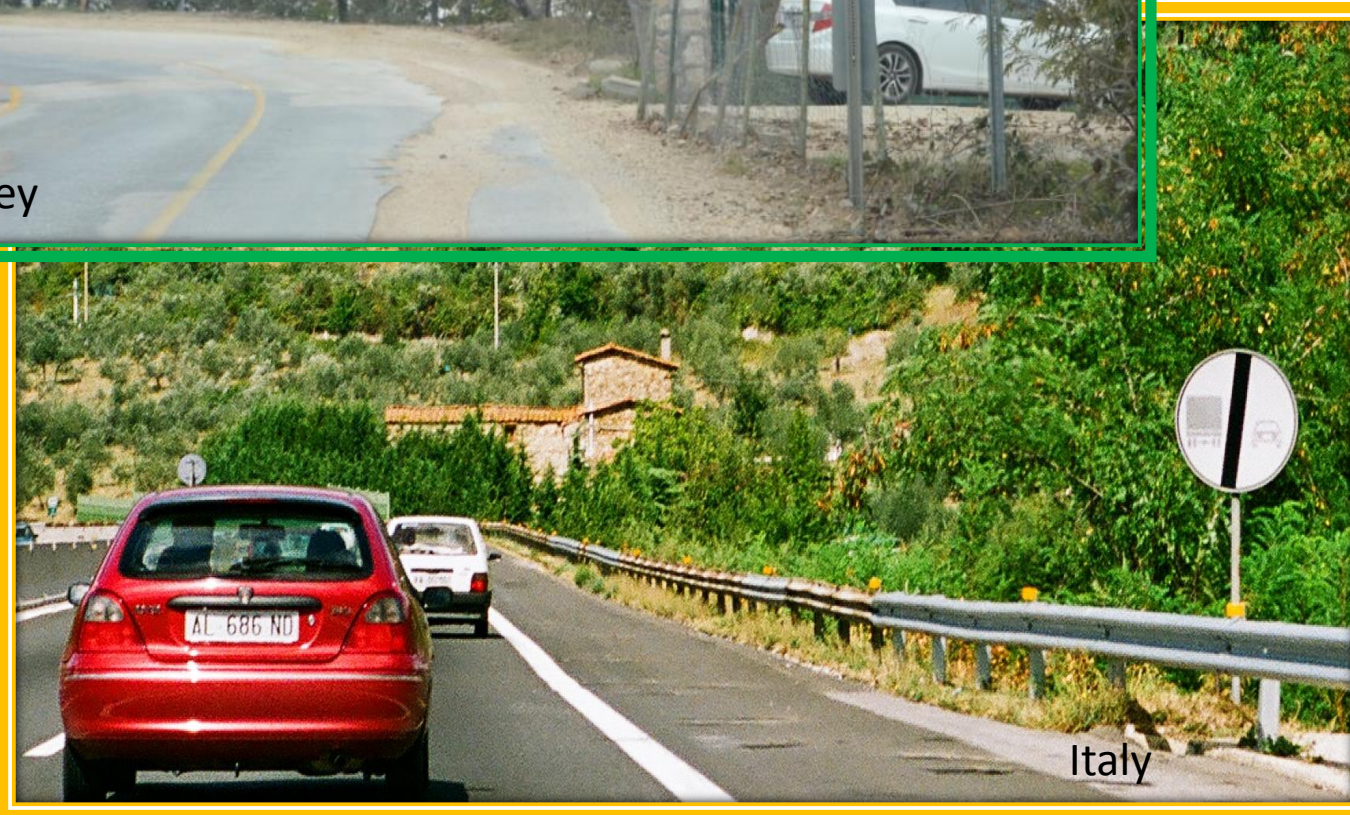

Italy



Italy

Practice 1

Tilting the Band.
Will not work with all symbols.



Practice 2

Cutting the Band.

Italy



France



Both Practices (Tilting & Cutting) are **Not** in **Conformity** with VC.

The sign to give the meaning of “Ending All Prohibition” should be cancelled and removed from VC for the reasons explained earlier.

Suggestion:

But if the Group of Expert sees it difficult to accept that, then I suggest C, 17a with the black **band** to be used only for “Ending All Prohibitions”, and with black **parallel lines** to be used only for “Ending Particular Prohibition”.

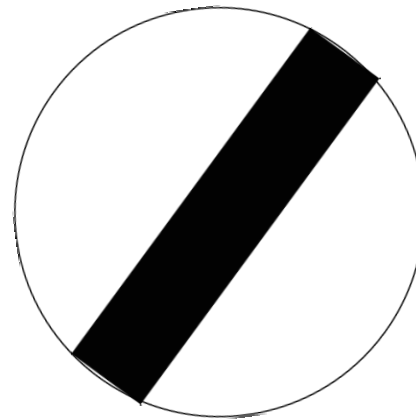

To be used **Only** for ending **all** prohibitions previously notified.

C, 17 ab , Y

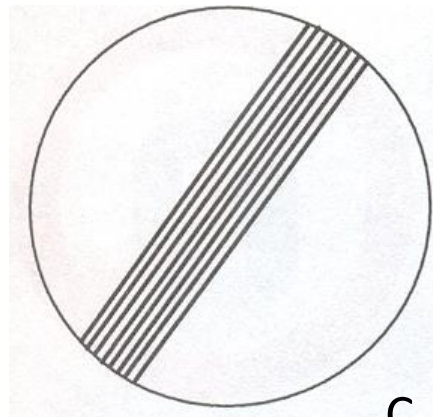
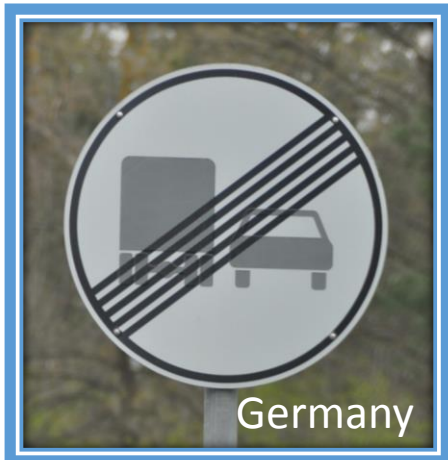

C, 17a, W

To be used **Only** for ending **particular** prohibition previously notified.

In this case, (C17a) should be a Model ,not a Sign same as Aa, Ab and F.

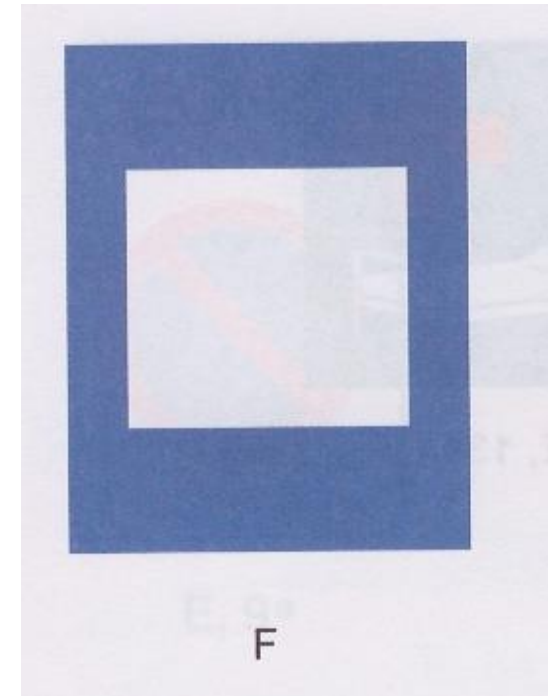
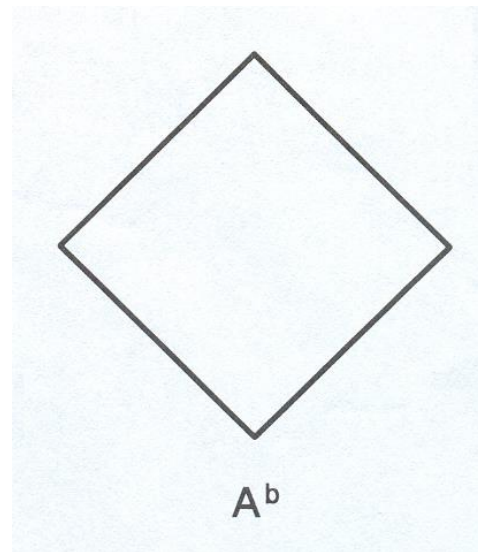
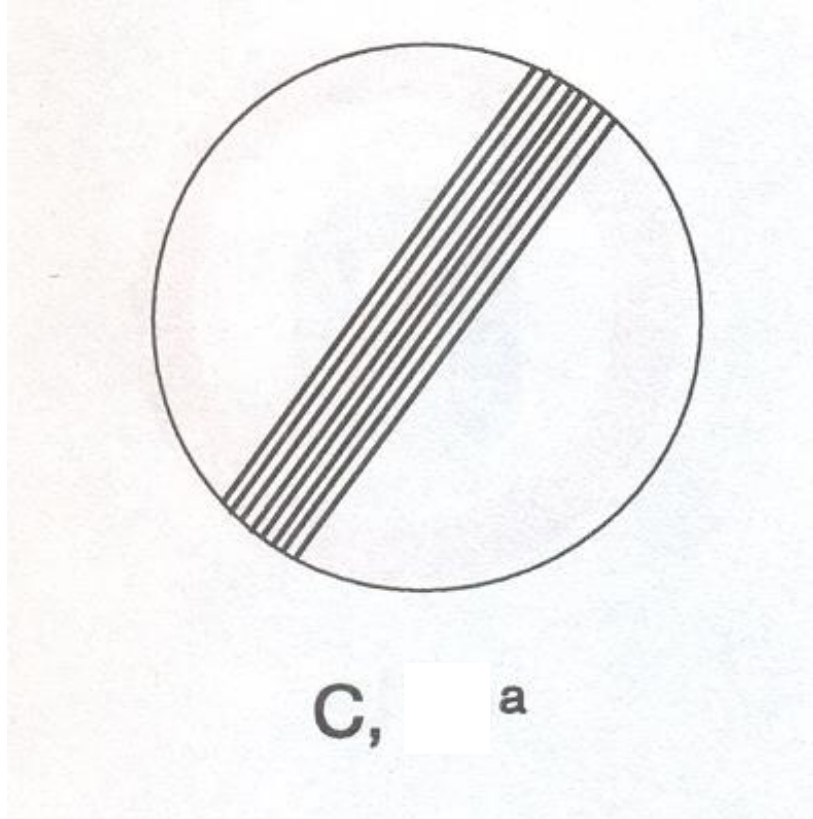



Switzerland

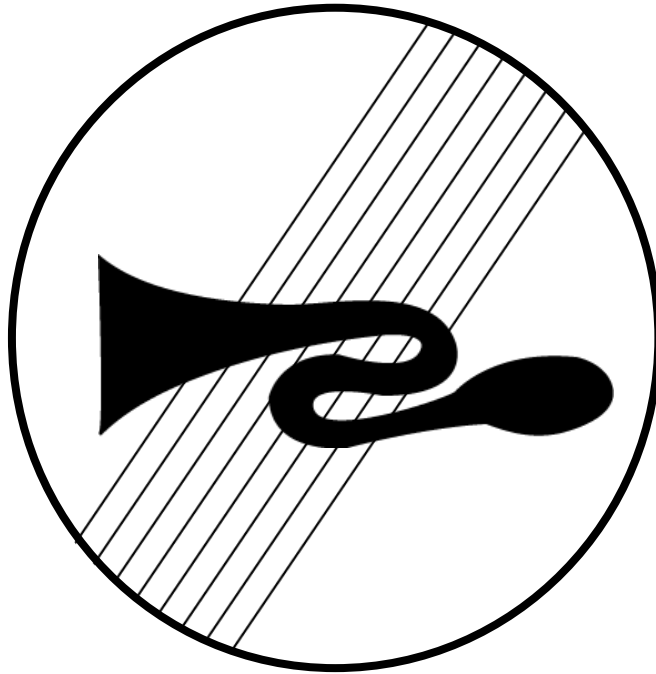

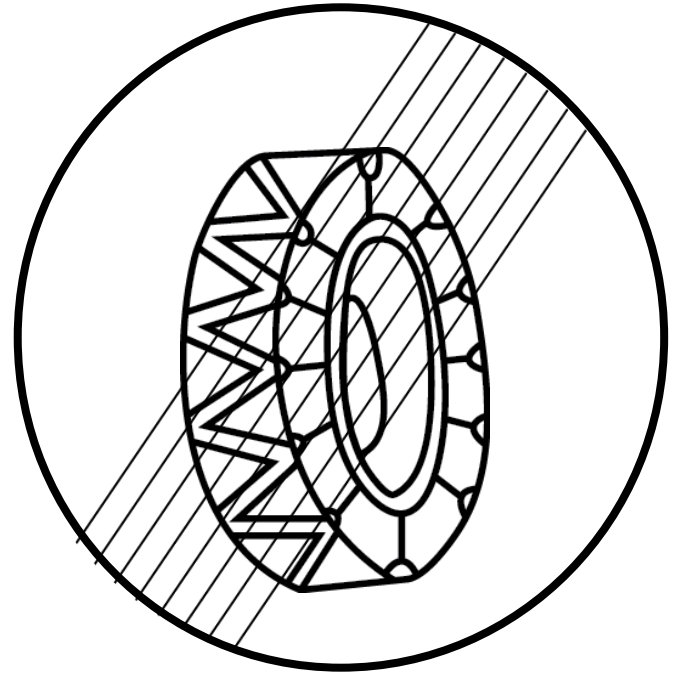
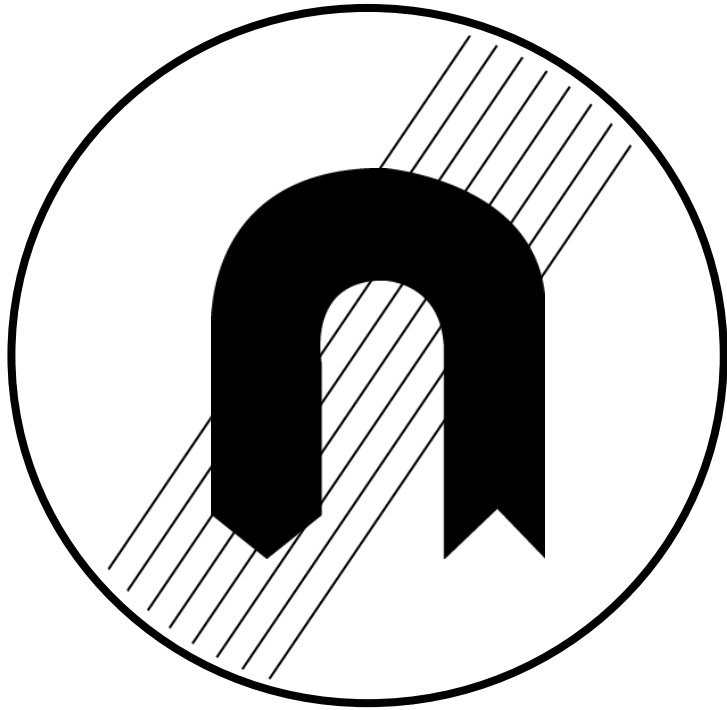

Viet Nam



Viet Nam



Tunisia

Japan



Exit from a Zones



E, 9^a



E, 9^b



E, 9^c



E, 9^d



E, 10^a



E, 10^b

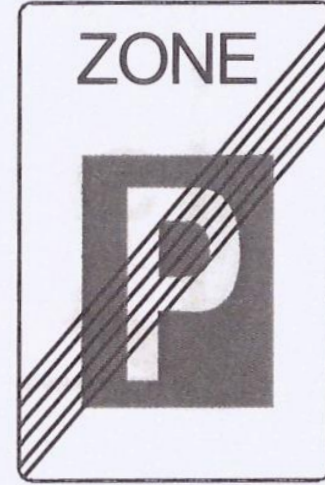

E, 10^c



E, 10^d

Probably it's a printing mistake, but because signs E, 10a and in E, 10b have a White Band with Parallel lines, drivers can not tell if they are for Ending of No Parking and No Stopping Zone or No Parking Zone only?



E, 10^a



E, 10^b



E, 10^c



Netherlands

Internet



Slovenia

Internet



Germany

France



France



Internet



Poland

Not in
Conformity
with VC.

Question ?



UK

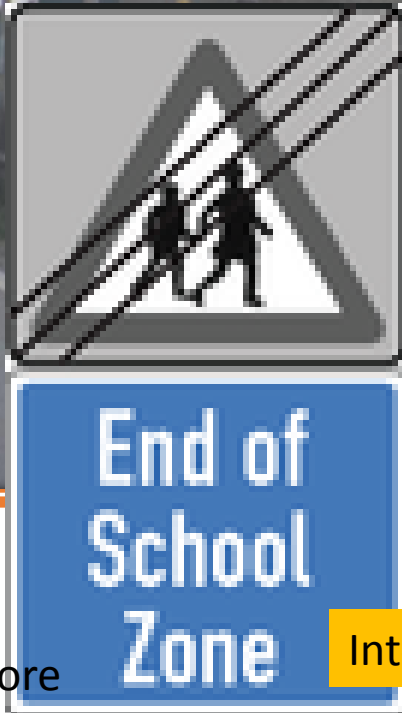

Singapore

Internet

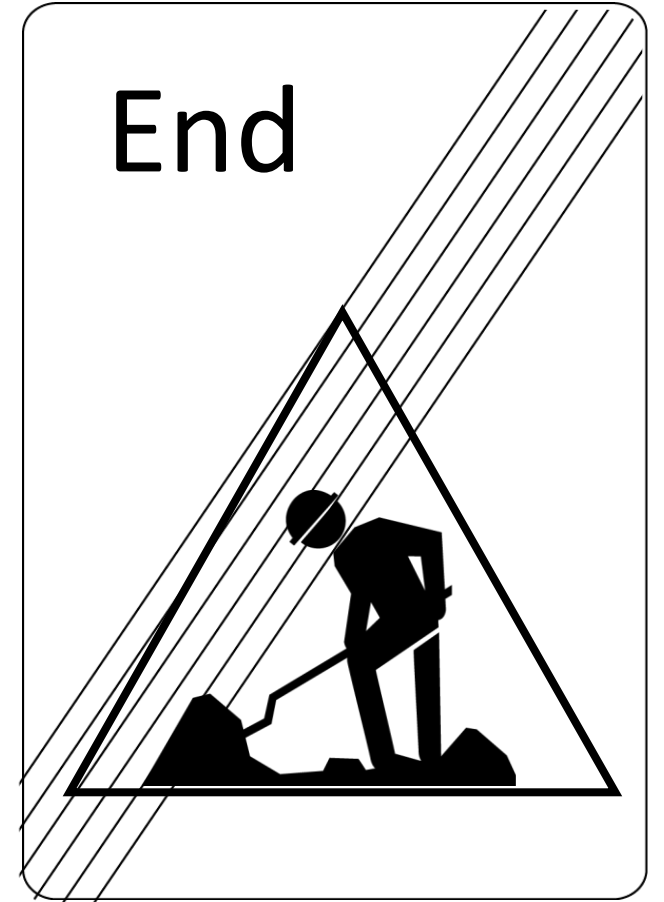

Should we **allow** C, 17a sign to be used for ending **Warning Zones** ?



Switzerland



Switzerland

S.Africa



U.A.E.



UK



ZONE

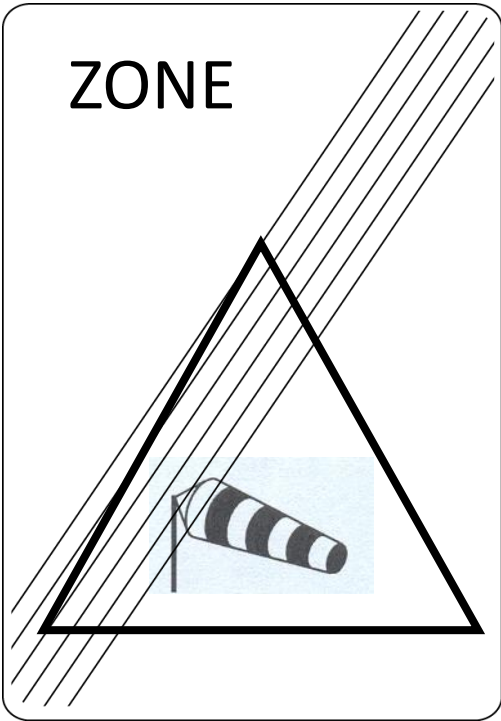

ZONE

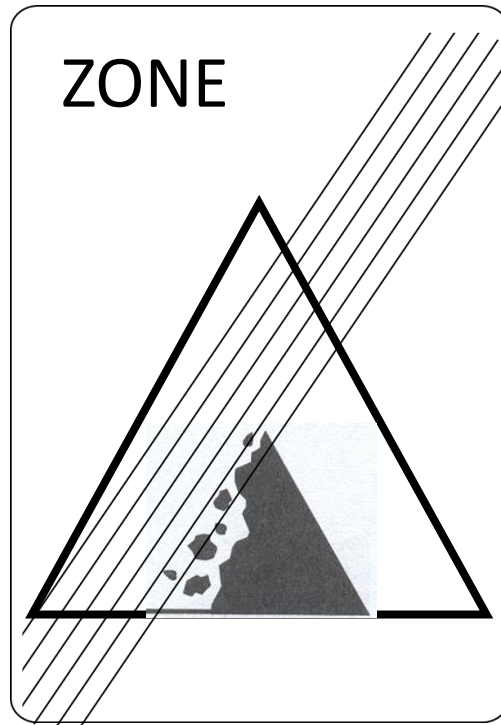

ZONE





Netherlands (3 Lines)

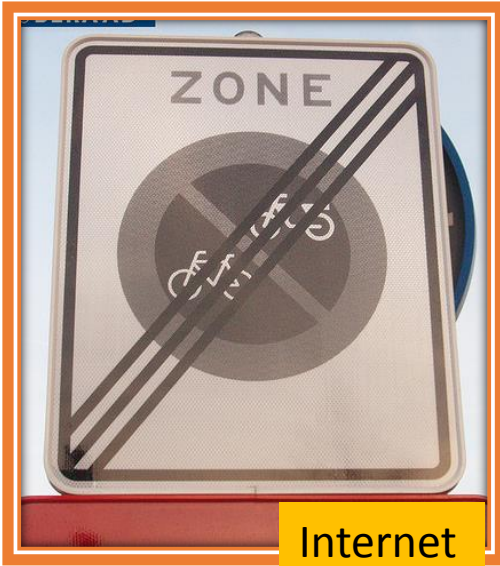

Internet

China (5 Lines)



Internet

Numbers of Lines



Switzerland (7 lines)

Holland (4 Lines)



Conclusion

- To design a sign, or to check if an existing sign is good, three steps should be followed, Finding the reasons, writing a safety message and finally translating the safety message to a sign by using the four elements (SSCW).
- VC should write a safety message to all signs.
- The definition for sign C, 17 should be revised.
- When VC allows a choice between several signs or symbols to be used, each should have its own number.
- “Ending All Prohibition” sign should be cancelled and removed from VC, if difficult to accept that, then C, 17a with the black band should be used only for “Ending All Prohibitions” , and with black parallel lines to be used only for “Ending Particular Prohibition”.
- C, 17 a should be a Model not a sign as Model Aa, Ab and F.
- the White Band with black parallel lines in sign E, 10a and E,10b should be changed to Black Parallel Lines.
- VC should specify the number of the Parallel Lines in all the C, 17 signs and End of Zone signs.

U.K.



Internet

Note: All Photos by Adel Alyousifi
except the ones has this symbol

Internet