

Economic Commission for Europe

Inland Transport Committee

27 October 2015

Working Party on the Transport of Dangerous Goods

Joint Meeting of Experts on the Regulations annexed to the European Agreement concerning the International Carriage of Dangerous Goods by Inland Waterways (ADN) (ADN Safety Committee)

Twenty-eighth session

Geneva, 25 - 29 January 2016

Item 4 (b) of the provisional agenda

Implementation of ADN:

Special authorizations, derogations and equivalents

Request for a temporary derogation for the tank vessel “Chemgas 851” for the use of a dry aerosol generating fire extinguishing system

Transmitted by the Government of the Netherlands

I. Introduction

1. In January 2014, the ADN Administrative Committee authorized the competent authority of the Netherlands to issue a trial certificate of approval to the motor tank vessel Chemgas 851 (Sirocco), official ID number 55679 and BV Register number 24521F, type G tanker, as referred to in the ADN, for the use of liquefied natural gas (LNG) as fuel for the propulsion installation.

2. Since then it has come to the attention of the competent authority of the Netherlands that the fire extinguishing agent used on board of the vessel does not comply with 9.3.1.40.2.1 of the Regulations annexed to ADN. The vessel uses a dry aerosol generating fire extinguishing system (FP5700S) which is not listed in the mentioned paragraph.

3. On 24 September 2015 the CCNR issued a recommendation which allows Chemgas 851 (Sirocco), under strict conditions, to use this dry aerosol generating fire extinguishing system as the permanently fixed fire-extinguishing agent in the engine room, the boiler room and the pump room. The decision was based on the technical reports which can be found in the Annex of this document.

II. Proposal

4. In accordance with the last sentence of 9.3.1.40.2.1 of the Regulations annexed to the ADN, the Government of the Netherlands requests the Administrative Committee to authorize the competent authority of the Netherlands to allow on board the motor tank vessel Chemgas 851 (Sirocco), official ID number 55679 and BV Register number 24521F, the use of this dry aerosol generating fire extinguishing system as the permanently fixed fire-extinguishing agent mentioned in the paragraph above.

5. Attached is in Annex I a proposed text for a possible derogation, and
 - CCNR Recommendation
 - Letter from Bureau Veritas to Dutch inspection body ILT
 - Type Examination Certificate
 - Production Quality Assurance Certificate
 - Information, Instruction and User Manual
 - FirePro calculation of the Sirocco
 - FirePro technical information FP5700S
 - Overview of Sirocco
-

Annex I

Decision of the ADN Administrative Committee relating to the tank vessel “Chemgas 851”

Derogation No. xx/2016 of xx January 2016

The competent authority of the Netherlands is authorized to issue an addition to the trial certificate of approval of the motor tank vessel Chemgas 851 (Sirocco), official ID number 55679 and BV Register number 24521F, type G tanker as referred to in ADN, for the use of a dry aerosol generating fire extinguishing system (FP5700S).

Pursuant to paragraph 1.5.3.2 of the Regulation annexed to ADN, the above-mentioned vessel may deviate until 31 December 2018 from the requirement:

1. 9.3.1.40.2.1, Extinguishing agent: The extinguishing agent is not listed in the paragraph. The vessel is equipped with a permanently fixed fire-extinguishing agent of the type dry aerosol generating fire extinguishing system (FP5700S).

The Administrative Committee had decided that the use of this dry aerosol generating fire extinguishing system is sufficiently safe if the conditions set by the CCNR are met at all times, and if:

1. All data related to the use of the dry aerosol generating fire extinguishing system (FP5700s) shall be collected by the carrier. The data shall be sent to the competent authority on request.
 2. After use of the permanently fixed fire-extinguishing agent, an evaluation report shall be sent to the UNECE secretariat for information of the Administrative Committee, including the operational data and the inspection report by the classification society which classed the vessel.
-

ZENTRAALKOMMISSION FÜR DIE RHEINSCHIFFFAHRT
EMPFEHLUNGEN AN DIE SCHIFFSUNTERSUCHUNGSKOMMISSIONEN
ZUR RHEINSCHIFFSUNTERSUCHUNGSORDNUNG

EMPFEHLUNG Nr. 26/2015
vom 24. September 2015

Zu § 10.03b Nr. 1 – fest installierte Feuerlöschanlagen in Maschinen-,
Kessel- und Pumpenräumen
Trockenes aerosolbildendes SBC¹ - Löschmittel
SIROCCO

In Anwendung des § 10.03b Nr. 1 letzter Satz RheinSchUO wird dem Tankmotorschiff „Sirocco“ - einheitliche europäische Schiffsnummer 55679 - unter den nachstehenden Bedingungen zugestanden, in den Maschinenräumen trockenes aerosolbildendes SBC-Löschmittel zu verwenden:

1. § 10.03b Nr. 2, Nr. 3, Nr. 5, Nr. 6 und Nr. 9 finden dementsprechend Anwendung.
2. Das trockene aerosolbildende SBC-Löschmittel ist typpenehmigt gemäß der Richtlinie 96/98/EG des Rates vom 20. Dezember 1996 über Schiffsausrüstung.
3. Jeder zu schützende Raum (Maschinenraum und Bugstrahlruderraum) muss mit einer eigenen Löschanlage ausgestattet werden.
4. Die zu schützenden Räume, in denen sich Gas- oder Zweistoffmotoren befinden, müssen nach den im IGF-Code festgelegten Bestimmungen für gassichere Maschinenräume angelegt sein.
5. Das trockene aerosolbildende SBC-Löschmittel wird in speziell dafür vorgesehenen drucklosen Behältern im zu schützenden Raum aufbewahrt. Diese Behälter müssen so angebracht sein, dass das Löschmittel gleichmäßig verteilt wird. Insbesondere muss das Löschmittel auch unter den Flurplatten wirken.
6. Die Inbetriebnahme der Löschanlage muss über eine elektrische Steuerung im Sinne von § 10.03b Nr. 5 Buchstabe c erfolgen. Jeder Behälter wird separat mit der Einrichtung für die Inbetriebnahme verbunden.
7. Beim Auslösen der Löschanlage muss die LNG-Zufuhr zum Motor über das Hauptventil automatisch geschlossen werden.
8. Die Menge an trockenem aerosolbildendem SBC-Löschmittel für den zu schützenden Raum muss mindestens 120 g/m³ des Bruttovolumens des Raums betragen.
9. Die Behälter mit Löschmittel müssen nach 15 Jahren ausgetauscht werden. Die Notstrom-batterien sind spätestens nach sechs Jahren auszutauschen.
10. Diese Empfehlung gilt ausschließlich für die Brandklassen A und B.

(Die der Erteilung der Empfehlung zugrundeliegenden technischen Unterlagen sind dem Dokument RV/G (15) 12 zu entnehmen.)

¹ Solid Bound Compound

COMMISSION CENTRALE POUR LA NAVIGATION DU RHIN**RECOMMANDATIONS AUX COMMISSIONS DE VISITE
RELATIVES AU REGLEMENT DE VISITE DES BATEAUX DU RHIN****RECOMMANDATION N° 26/2015
du 24 septembre 2015**

Ad Article 10.03ter, chiffre 1 - Installations d'extinction fixées à demeure dans les salles des machines, salles de chauffe et chambres des pompes
Agent extincteur SBC² formant un aérosol sec
SIROCCO

En application de l'article 10.03ter, chiffre 1, dernière phrase, du RVBR, l'automoteur-citerne "Sirocco", numéro européen unique d'identification des bateaux 55679, est autorisé à utiliser dans les salles des machines l'agent extincteur SBC formant un aérosol sec, aux conditions suivantes :

1. L'article 10.03ter, chiffres 2, 3, 5, 6 et 9, est applicable.
2. L'agent extincteur formant un aérosol sec est agréé par type conformément à la Directive 96/98/CE du Conseil du 20 décembre 1996 relative aux équipements marins.
3. Chaque local à protéger (salle des machines et salle du propulseur d'étrave) doit être équipé de sa propre installation d'extinction.
4. Les locaux à protéger, dans lesquels des moteurs à gaz ou bicom bustibles sont installés, doivent être conformes aux règles pour les salles des machines protégées contre le gaz telles que fixées par le code IGF.
5. L'agent extincteur SBC formant un aérosol sec est conservé dans des réservoirs non pressurisés spécifiquement prévus à cet effet dans le local à protéger. Ces réservoirs doivent être installés de manière à ce que l'agent extincteur puisse se répartir uniformément. L'agent extincteur doit notamment agir aussi sous le plancher.
6. Le déclenchement de l'installation d'extinction doit se faire au moyen d'un dispositif de commande électrique tel que visé à l'article 10.03ter, chiffre 5, lettre c). Chaque réservoir doit être relié individuellement au dispositif de déclenchement.
7. Lorsque l'installation d'extinction se déclenche, l'alimentation du moteur en GNL doit être arrêtée automatiquement par le biais de la vanne principale.
8. La quantité d'agent extincteur SBC formant un aérosol sec correspondant au local à protéger doit être d'au moins 120 g par m³ de volume brut du local concerné.
9. Les réservoirs contenant l'agent extincteur doivent être remplacés après 15 ans. Les batteries de secours doivent être remplacées après 6 ans au plus tard.
10. La présente recommandation s'applique uniquement aux classes de feu A et B.

(Les données techniques tenant lieu de base pour la présente recommandation figurent au document RV/G (15) 12.)

² Solid Bound Compound

CENTRALE COMMISSIE VOOR DE RIJNVAART

**AANBEVELINGEN AAN DE COMMISSIES VAN DESKUNDIGEN MET
BETREKKING TOT DE TOEPASSING VAN HET REGLEMENT ONDERZOEK SCHEPEN
OP DE RIJN**

**AANBEVELING Nr. 26/2015
van 24 september 2015**

Bij Artikel 10.03b, eerste lid - Vast ingebouwde brandblusinstallaties in machinekamers,
ketelruimen en pompkamers
Droog aerosolvormend SBC³-blusmiddel

SIROCCO

Voor de toepassing van artikel 10.03b, eerste lid, laatste volzin, van het ROSR, wordt op het motortankschip "Sirocco" - uniek Europees scheepsidentificatienummer 55679 - toegestaan om het droge aerosolvormende SBC-blusmiddel in de machinekamers toe te passen, onder de volgende voorwaarden:

1. Artikel 10.03b, tweede, derde, vijfde, zesde en negende lid moeten in acht worden genomen.
2. Het droge aerosolvormende SBC-blusmiddel is typegoedgekeurd volgens Richtlijn 96/98/EG van de Raad van 20 december 1996 inzake uitrusting van zeeschepen.
3. Iedere te beschermen ruimte (machinekamer en boegschroefruimte) moet met een eigen blusinstallatie worden uitgerust.
4. De te beschermen ruimten waarin gas- of dual-fuelmotoren zijn geïnstalleerd, moeten voldoen aan de regels voor gasveilige machinekamers zoals neergelegd in de IGF-code.
5. Het droge aerosolvormende SBC-blusmiddel wordt in speciaal daarvoor voorziene drukloze reservoirs in de te beschermen ruimte opgeslagen. Deze reservoirs moeten zodanig zijn aangebracht dat het blusmiddel gelijkmatig wordt verdeeld. In het bijzonder moet het blusmiddel ook onder de vloerplaten werkzaam zijn.
6. Het in werking stellen van de blusinstallatie moet via een elektrische besturing als bedoeld in artikel 10.03b, vijfde lid, onderdeel c, geschieden. Ieder reservoir wordt afzonderlijk met de inrichting voor het in werking stellen verbonden.
7. Bij inwerkingtreding van de blusinstallatie moet de LNG-toevoer naar de motor via het hoofdventiel automatisch worden afgesloten.
8. De hoeveelheid droog aerosolvormend SBC-blusmiddel voor de te beschermen ruimte moet ten minste 120 g/m³ van het brutovolume van de ruimte bedragen.
9. De reservoirs met blusmiddel moeten na 15 jaren worden vervangen. De noodstroombatterijen moeten uiterlijk na zes jaren worden vervangen.
10. Deze aanbeveling geldt uitsluitend voor de brandklassen A en B.

(De technische bescheiden waarop de aanbeveling is gebaseerd kunnen in document RV/G (15) 12 worden gevonden.)

³ Solid Bound Compound



INSPECTIE LEEFOMGEVINGEN
 TRANSPORT
 tav Dhr L. Korvink
 P.O. BOX 16191
 2500 BD DEN HAAG

Rotterdam, 11/11/2014

Subject : Aerosol aanbeveling Sirocco 02335784

Our Ref : RTD Office/2014/019796/E WH

Dear Mr Korvink,

The aerosol installation on board of the Sirocco complies with the listed items as mentioned in the attached request for derogation (except for point 6 as this is a remark for the future).

The combustion air for the main engine is taken from outside the engine room. The Engine Room is a 'Gas safe machinery space'; this means that following the text of the IGF guideline "arrangements in machinery spaces are such that the spaces are considered gas safe under all conditions, normal as well as abnormal conditions, i.e. inherently gas safe." "In a gas safe machinery space a single failure cannot lead to release of fuel gas into the machinery space." So the presence of LNG in the volume of the ER would not be possible and consequently a fire involving gas (Class C fire) could not be possible.

Class A & B fires are covered by the attached approvals and are similar to conventional propelled vessels.

Best regards,

 Liesbeth den Haan
 Bureau Veritas



EC Type Examination Certificate

This is to certify that:

FirePro Systems Limited
6 Koumandarias & Spyrou Araouzou Street
Tonia Court No2, 6th Floor
Limassol 3036
Cyprus

Holds Certificate Number:

BSI/A.1/3.46/560436

In respect of:

Directive reference: MED 96/98/EC, as amended, last amended by directive 2011/75/EU
Annex A1 Item: A.1/3.46 - Equivalent fixed gas fire extinguishing systems for machinery spaces (aerosol systems)
Product Type: Aerosol Fire Extinguishing Units with dry condensed extinguishing agent, Fire Class A & B
Product Description: FP20S, FP20SE, FP40S, FP80S, FP100S, FP200S, FP500S, FP1200, FP1200S, FP2000, FP2000S, FP3000, FP3000S, FP5700 and FP5700S.
Specified standard: IMO MSC/Circ.1007, MSC/Circ 1270

This is to certify that BSI did undertake the relevant type approval procedures for the equipment identified above which was found to be in compliance with the Fire protection requirements of Module B of the Marine Equipment Directive (MED) 96/98/EC, as amended, last amended by Directive (2011/75/EU), subject to any conditions in the schedule attached hereto.

For and on behalf of BSI,
a Notified Body for the above Directive
(Notified Body Number 0086):



Gary Fenton, Global Assurance Director

The attached schedule of approval forms part of this certificate.

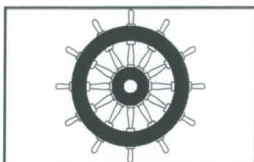

0086/yy

Notes:

- (i) The certificate will not be valid if the manufacturer makes any changes or modifications to the approved equipment, which have not been notified to, and agreed with the notified body named on this certificate.
- (ii) Should the specified regulations or standards be amended during the validity of this certificate, the product(s) is/are to be re-approved prior to it/they being placed on board vessels to which the amended regulations or standards apply.
- (iii) "The mark of conformity may only be affixed to the above type approved equipment and a Manufacturers Declaration of Conformity issued when the production-control phase Module (D, E or F) of Annex B of the directive is fully complied with and controlled by a written inspection agreement with a notified body."
"Wheelmark" Format yy Last two digits of year mark affixed, 0086 Notified Body undertaking surveillance module.

First Issued: 20 August 2010

Latest Issue: 09 September 2013

Expiry Date: 19 August 2015

Page 1 of 13

EC Type Examination Certificate

No. **BSI/A.1/3.46/560436**

Schedule of Approval

Manufacturer Address:

FirePro Systems Limited
Ayios Athansios
4 Falea Street
Limassol District
Cyprus

Product Specification

The products listed below are to be installed with an actuation system/panel where manual activation is achieved as defined in MSC1/Circ 1270 chapter 17 and as per the FirePro User/Installation manual. The actuation system/panel is excluded from this certification.

- FP20S : Aerosol generating fire extinguishing system unit with 20g dry condensed extinguishing agent, thermal activation by thermocord at 172 °C, Fire Class A & B
- FP20SE : Aerosol generating fire extinguishing system unit with 20g dry condensed extinguishing agent electrical activation (6 - 36 V D/C 0.8 A in 3 - 4 sec), heating element with 2.3 ohm resistance , Fire Class A & B
- FP40S : Aerosol generating fire extinguishing system unit with 40g dry condensed extinguishing agent, thermal activation by thermocord at 172 °C, electrical activation (6 - 36 V D/C 0.8 A in 3 - 4 sec), heating element with 2.3 ohm resistance , Fire Class A & B
- FP80S : Aerosol generating fire extinguishing system unit with 80g dry condensed extinguishing agent, thermal activation by thermocord at 172 °C, electrical activation (6 - 36 V D/C 0.8 A in 3 - 4 sec), heating element with 2.3 ohm resistance , Fire Class A & B
- FP100S : Aerosol generating fire extinguishing system unit with 100g dry condensed extinguishing agent, thermal activation by thermocord at 172 °C, electrical activation (6 - 36 V D/C 0.8 A in 3 - 4 sec), heating element with 2.3 ohm resistance , Fire Class A & B
- FP200S : Aerosol generating fire extinguishing system unit with 200g dry condensed extinguishing agent, thermal activation by thermocord at 172 °C, electrical activation (6 - 36 V D/C 0.8 A in 3 - 4 sec), heating element with 2.3 ohm resistance , Fire Class A & B

First Issued: 20 August 2010

Latest Issue: 09 September 2013

Expiry Date: 19 August 2015

Page 2 of 13

...making excellence a habit.™



EC Type Examination Certificate

No. **BSI/A.1/3.46/560436**

Schedule of Approval

Product Specification (continued)

- FP500S : Aerosol generating fire extinguishing system unit with 500g dry condensed extinguishing agent, thermal activation by thermocord at 172 °C, electrical activation (6 - 36 V D/C 0.8 A in 3 - 4 sec), heating element with 2.3 ohm resistance , Fire Class A & B
- FP1200/FP1200S : Aerosol generating fire extinguishing system unit with 1200g dry condensed extinguishing agent, thermal activation by thermocord at 172 °C, electrical activation (6 - 36 V D/C 0.8 A in 3 - 4 sec), heating element with 2.3 ohm resistance , Fire Class A & B
- FP2000/FP2000S : Aerosol generating fire extinguishing system unit with 2000g dry condensed extinguishing agent, thermal activation by thermocord at 172 °C, electrical activation (6 - 36 V D/C 0.8 A in 3 - 4 sec), heating element with 2.3 ohm resistance , Fire Class A & B
- FP3000/FP3000S : Aerosol generating fire extinguishing system unit with 3000g dry condensed extinguishing agent, thermal activation by thermocord at 172 °C, electrical activation (6 - 36 V D/C 0.8 A in 3 - 4 sec), heating element with 2.3 ohm resistance , Fire Class A & B
- FP5700/FP5000S : Aerosol generating fire extinguishing system unit with 5700g dry condensed extinguishing agent, thermal activation by thermocord at 172 °C, electrical activation (6 - 36 V D/C 0.8 A in 3 - 4 sec), heating element with 2.3 ohm resistance , Fire Class A & B

First Issued: 20 August 2010

Latest Issue: 09 September 2013

Expiry Date: 19 August 2015

Page 3 of 13

...making excellence a habit.™

EC Type Examination Certificate

No. BSI/A.1/3.46/560436

Schedule of Approval

Approval Documentation that forms part of this certification:

Drawing No.	Rev/Issue	Date	Title
C20ASS	0	17/01/2009	FP20S – General Assembly Drawing
C20EASS	0	17/01/2009	FP20SE – General Assembly Drawing
C40ASS	0	16/01/2008	FP40S – General Assembly Drawing
C80ASS	0	16/01/2008	FP80S – General Assembly Drawing
C1AS	2	29/05/2009	FP100S – General Assembly Drawings
C2AS	2	25/05/2009	FP200S – General Assembly Drawings
C5AS	2	16/02/2009	FP500S – General Assembly Drawings
B12AS	0	01/01/2008	FP1200 – General Assembly Drawing
B12EH	0	01/01/2008	FP1200 – External Housing Construction Drawing
B12IH	0	01/01/2008	FP1200 – Internal Housing Construction Drawing
B12IAS	0	01/01/2008	FP1200 – Internal Assembly Drawing
B20AS	0	01/01/2008	FP2000 – General Assembly Drawing
B20IAS	0	01/01/2008	FP2000 – Internal Assembly Drawing
B30AS	0	01/01/2008	FP3000 – General Assembly Drawing
B30IAS	0	01/01/2008	FP3000 – Internal Assembly Drawing
B2030EH	1	01/01/2008	FP2000 & FP3000 – External Housing Construction Drawing
B2030IH	0	01/01/2008	FP2000 & FP3000 – Internal Housing Construction Drawing
B122020BRKT	0	01/01/2008	FP1200 – Mounting Bracket
B2030BRKT	0	01/01/2008	FP2000 & FP3000 – Mounting Bracket
B57EH	1	01/10/2008	FP 5700 – External Housing Construction Drawing
B57IH	0	01/01/2008	FP5700 – Internal Housing Construction Drawing
B57IAS	0	01/01/2008	FP5700 – Internal Assembly Drawing
B57BRKT	0	01/01/2008	FP5700 – Mounting Bracket
AELACT	0	01/01/2008	Electrical Activators for all Models where fitted

First Issued: 20 August 2010

Latest Issue: 09 September 2013

Expiry Date: 19 August 2015

Page 4 of 13

...making excellence a habit.™

EC Type Examination Certificate

No. BSI/A.1/3.46/560436

Schedule of Approval

Approval Documentation that forms part of this certification (continued):

Drawing No.	Rev/Issue	Date	Title
B122030BRKT	1	01/08/2012	FP1200S, FP2000S, FP3000S – Mild Steel Mounting Bracket
B12EHBC	1	01/08/2012	FP1200S – External Housing Bottom Cover
B12EHSW	1	01/08/2012	FP1200S – External Housing Side Walls
B12EHTC	1	01/08/2012	FP1200S – External Housing Top Cover
B203057EHBC	1	01/08/2012	FP2000S, FP3000S, FP5700S – External Housing Bottom Cover
B203057EHTC	1	01/08/2012	FP2000S, FP3000S, FP5700S – External Housing Top Cover
B2030EHSW	2	01/08/2012	FP2000S, FP3000S – External Housing Side Walls
B57BRKT	1	01/08/2012	FP5700S – Mounting Bracket
B57EHSW	2	01/08/2012	FP5000S – External Housing Side Wall
Supporting Documentation			
Technical Dossier	0	22/07/2010	SMO Ref 7498123– Electronic copy of the Technical file covering all models listed on page 1
Technical Dossier		Feb 2012	Updated to include minor changes to some drawings, Efectis Witness Test Report and Updated KIWA Certificate
Technical Dossier		Aug 2012	Updated to include Model FP20SE, Previous Technical Dossier included the information for this model, no change to the Technical Dossier.
Technical Dossier		Aug 2013	SMO Ref 8030440 - Updated to include variant Models FP1200S, FP2000S, FP3000S & FP5700S. The only difference being the external housing being made from Stainless Steel, no other change to the product.
Manuals	5	01/10/2011	Information, Instruction & User Manual
	5	Revised 26/08/2013	Information, Instruction & User Manual – Updated to include models FP1200S, FP2000S, FP3000S & FP5700S
	2	14/02/2012	Annex 1 Marine Manual to be read in conjunction with the above manual

First Issued: 20 August 2010

Latest Issue: 09 September 2013

Expiry Date: 19 August 2015

EC Type Examination Certificate

No. BSI/A.1/3.46/560436

Schedule of Approval

Approval Documentation that forms part of this certification (continued):

Supporting Documentation (continued)			
Document	Rev/Issue	Date	Title
Reports & Certificates	-	-	KIWA Certificate K21477/08 01/04/2010 UL Test Report, Project Ref 05CA05359, File EX6960 USCG Report CG-D-03-06 Russian Maritime Register of Shipping, Type approval Certificate Ref 10.80012.180 dated 11/06/2010 for MCS 1270 * Hughes Associates INC Analysis Report dated Nov 2004 & 15/01/2009 **
	-	06/08/2010	Technical Dossier Assessment Report 2411/7498123
	-	Aug 2011	K21477/08 01/08/2011
		26/01/2012	Cone Calorimeter Tests of IMO MSC Circ 1270 Class A Plastic Materials – Hughes Associates Inc
	-	Jan 2012	Efectis Test Report R1134, Fire test - Wood Cribs & Plastic Sheets
		12/09/2011	KIWA, EMC Test Report 126076-EMC

* The Russian Maritime Register of Shipping has made an independent evaluation of the test reports owned by FirePro and according to their opinion it satisfied the requirements of the MSC.1/Circ.1270. Since the Certification list is reporting all the approval documents received so far by FirePro, the Russian Registry Type Approval was included in the above list.

** The Hughes Report is that at the time MCA requested FirePro to run additional tests, the opinion of FirePro was that they had already run the additional tests as part of the listing with various accredited Institutes, such as UL. Therefore FirePro asked Hughes Associates, the largest in the world Fire Risk Assessment Company, to carry out an evaluation and provide their independent opinion on this issue. Mr.L.Borghetti (Hughes Europe) was the chairman of the CEN,ISO and IMO technical committees on the aerosol technology and therefore he is in position to give a competent opinion on the issue.
The conclusion of Hughes Analysis Report is: " FirePro was participating and contributing to the research and test campaign headed by USCG, having the scope to develop the information necessary for the revision of the existing IMO MSC/Circ.1007 (now IMO MSC/Circ.1270). The FirePro Aerosol Extinguishing Systems passed all the tests and requirements stated by the revised IMO MSC/Circ.1270 as reported by the USCG, the polymeric Sheet Test has been witnessed as passed by the listing issued by the Underwriters Laboratories.

First Issued: 20 August 2010

Latest Issue: 09 September 2013

Expiry Date: 19 August 2015

EC Type Examination Certificate

No. BSI/A.1/3.46/560436

Schedule of Approval

Design Calculation - Agent

The quantity (mass) of aerosol agent to be used should be determined as follows:

$$W = \frac{V \times q \text{ (g)}}{f}$$

where

W = Agent mass (g) (Total mass required to protect the specific volume)

V = Volume of enclosure (m³) (Protected volume)

q = Design application density (gr/m³) (net mass of agent per unit volume (g/m³) required by the system designer for the fire protection application)

f = Efficiency coefficient of generator's model (%) (net mass of agent delivered by a generator model (size))

q = 120 gr/m³

Efficiency coefficients (related to each generator model (size)):

FP-20S/SE= 60%

FP-500S = 63%

FP-40S= 63%

FP-1200 = 65%

FP-80S= 60%

FP-2000 = 61%

FP-100S = 63%

FP-3000 = 62%

FP-200S = 61%

FP-5700 = 61%

The total number of generators (N) to be used is derived by the following formula

$$N = \frac{W \text{ (total agent mass)}}{\text{nominal mass (initial mass of the solid compound) of each generator model (size)}}$$

Example: FP2000 = 2000 grams of nominal mass

FP5700 = 5700 grams of nominal mass

Note: If different generator models (size) should be selected, the total mass of extinguishant (solid compound) shall not be less than the quantity required (W).

First Issued: 20 August 2010

Latest Issue: 09 September 2013

Expiry Date: 19 August 2015

Page 7 of 13

EC Type Examination Certificate

No. **BSI/A.1/3.46/560436**

Schedule of Approval

Technical Specification

Model

Type
Activation mechanism FP20S ♦
Activation mechanism FP20SE ♦
Current intensity to be tested
Weight gross
Weight net extinguishing agent
Operational discharge time
Discharge outlet
Discharge length
Size
Self activation temperature

FP-20S / FP20SE

Cold
thermal activation by thermocord at 172°C
electrical (6 - 36 V D/C 0.8 A in 3 - 4 sec)
maximum 5 mA
310 g
20 g
5 - 10 seconds
2
0.6 m
165 mm x 32 mm (incl. connector housing)
300°C

Model

Type
Activation mechanism ♦

Activator type
Current intensity to be tested
Weight gross
Weight net extinguishing agent
Operational discharge time
Discharge outlets
Discharge length
Size
Self activation temperature

FP-40S

Cold
thermal activation by thermocord at 172°C
electrical (6 - 36 V D/C 0.8 A in 3 - 4 sec)
heating element with 2.3 ohm resistance
maximum 5 mA
610 g
40 g
5 - 10 seconds
2
1.2 m
140 mm x 51 mm
300°C

♦ See Product Specification note on Page 2

First Issued: 20 August 2010

Latest Issue: 09 September 2013

Expiry Date: 19 August 2015

Page 8 of 13

...making excellence a habit.™

EC Type Examination Certificate

No. **BSI/A.1/3.46/560436**

Schedule of Approval

Technical Specification (continued)

Model	FP-80S
Type	Cold
Activation mechanism ♦	thermal activation by thermocord at 172°C electrical (6 - 36 V D/C 0.8 A in 3 - 4 sec)
Activator type	heating element with 2.3 ohm resistance
Current intensity to be tested	maximum 5 mA
Weight gross	870 g
Weight net extinguishing agent	80 g
Operational discharge time	5 - 10 seconds
Discharge outlets	2
Discharge length	2 m
Size	185 mm x 51 mm (incl. connector housing)
Self activation temperature	300°C

Model	FP-100S
Type	Cold
Activation mechanism ♦	thermal activation by thermocord at 172°C electrical (6 - 36 V D/C 0.8 A in 3 - 4 sec)
Activator type	Heating element with 2.3 ohm resistance
Current intensity to be tested	Maximum 5 mA
Weight gross	1370 g
Weight net extinguishing agent	100 g
Operational discharge time	5 - 10 seconds
Nozzle	optional
Discharge outlet	1
Discharge length	1 m
Size	155 mm x 84 mm (incl. connector housing)
Self activation temperature	300°C

♦ See Product Specification note on Page 2

First Issued: 20 August 2010

Latest Issue: 09 September 2013

Expiry Date: 19 August 2015

Page 9 of 13

...making excellence a habit.™

EC Type Examination Certificate

No. **BSI/A.1/3.46/560436**

Schedule of Approval

Technical Specification (continued)

Model	FP-200S
Type	Cold
Activation mechanism ♦	thermal activation by thermocord at 172°C electrical (6 - 36 V D/C 0.8 A in 3 - 4 sec)
Activator type	heating element with 2.3 ohm resistance
Current intensity to be tested	maximum 5 mA
Weight gross	1840 g
Weight net extinguishing agent	200 g
Operational discharge time	5 - 10 seconds
Nozzle	Optional
Discharge outlet	1
Discharge length	2 m
Size	185 mm x 84 mm (incl. connector housing)
Self activation temperature	300°C

Model	FP-500S
Type	Cold
Activation mechanism ♦	thermal activation by thermocord at 172°C electrical (6 - 36 V D/C 0.8 A in 3 - 4 sec)
Activator type	heating element with 2.3 ohm resistance
Current intensity to be tested	maximum 5 mA
Weight gross	3340 g
Weight net extinguishing agent	500 g
Operational discharge time	5 - 10 seconds
Discharge outlet	1
Discharge length	2.5 m
Size	295 mm x 84 mm (incl. connector housing)
Self activation temperature	300°C

♦ See Product Specification note on Page 2

First Issued: 20 August 2010

Latest Issue: 09 September 2013

Expiry Date: 19 August 2015

Page 10 of 13

...making excellence a habit.™

EC Type Examination Certificate

No. **BSI/A.1/3.46/560436**

Schedule of Approval

Technical Specification (continued)

Model	FP-1200 / FP1200S
Type	Cold
Activation mechanism ♦	thermal activation by thermocord at 172°C electrical (6 - 36 V D/C 0.8 A in 3 - 4 sec)
Activator type	heating element 2.3 ohm resistance
Current intensity to be tested	maximum 5 mA
Weight gross	10900 g (excl bracket)
Weight net extinguishing agent	1200 g
Operational discharge time	10 -15 seconds
Discharge outlet	1
Discharge length	3.5 m
Size	216 mm x 300 mm x 167 mm
Self activation temperature	300°C

Model	FP-2000 / FP2000S
Type	Cold
Activation mechanism ♦	thermal activation by thermocord at 172°C electrical (6 - 36 V D/C 0.8 A in 3-4 sec)
Activator type	heating element 2.3 ohm resistance
Current intensity to be tested	maximum 5 mA
Weight gross	15500 g
Weight net extinguishing agent	2000 g
Operational discharge time	10 - 15 seconds
Discharge outlet	1
Discharge length	3.5 m
Size	300 mm x 300 mm x 185 mm
Self activation temperature	300°C

♦ See Product Specification note on Page 2

First Issued: 20 August 2010

Latest Issue: 09 September 2013

Expiry Date: 19 August 2015

Page 11 of 13

...making excellence a habit.™

EC Type Examination Certificate

No. **BSI/A.1/3.46/560436**

Schedule of Approval

Technical Specification (continued)

Model	FP-3000 / FP3000S
Type	Cold
Activation mechanism ♦	thermal activation by thermocord at 172°C electrical (6 - 36 V D/C 0.8 A in 3-4 sec)
Activator type	heating element 2.3 ohm resistance
Current intensity to be tested	maximum 5 mA
Weight gross	16300 g
Weight net extinguishing agent	3000 g
Operational discharge time	15 - 20 seconds
Discharge outlet	1
Discharge length	4 m
Size	300 mm x 300 mm x 185 mm
Self activation temperature	300°C

Model	FP-5700 / FP5700S
Type	Cold
Activation mechanism ♦	thermal activation by thermocord at 172°C electrical (6 - 36 V D/C 0.8 A in 3-4 sec)
Activator type	heating element 2.3 ohm resistance
Current intensity to be tested	maximum 5 mA
Weight gross	26400 g
Weight net extinguishing agent	5700 g
Operational discharge time	15 - 20 seconds
Discharge outlet	1
Discharge length	8 m
Size	300 mm x 300 mm x 300 mm
Self activation temperature	300°C

♦ See Product Specification note on Page 2

First Issued: 20 August 2010

Latest Issue: 09 September 2013

Expiry Date: 19 August 2015

Page 12 of 13

...making excellence a habit.™



EC Type Examination Certificate

No. **BSI/A.1/3.46/560436**

Schedule of Approval

Conditions of Certification

- i) This BSI/A.1/3.46/560436 issue 4 certificate remains valid unless cancelled or revoked, provided the conditions listed below are complied with and the equipment remains satisfactory in service
- ii) The equipment detailed on page 1 on this certificate is to be manufactured in accordance with Production Quality Assurance system (Module D)
- iii) Detailed User instructions are to be provided with each product.
- iv) The activation system supplied shall comply with all the requirements of MSC.1/Circ.1270, in particular clauses 12.1, 14 and 17"
- v) If the specified standards are amended during the validity of this certificate, this product type is to be re-approved prior to it being supplied to vessels to which the amended standards apply.
- vi) Production tests are to be conducted in accordance with the applicable requirements of the IMO Resolutions and applicable standards and be recorded by the manufacturer in accordance with the approved Production Quality Assurance system (Module D) of the Marine Equipment Directive.
- vii) Each item, batch or lot of the equipment is to have the "Mark of Conformity" affixed and be issued with a "Declaration of Conformity".

First Issued: 20 August 2010

Latest Issue: 09 September 2013

Expiry Date: 19 August 2015

Page 13 of 13

...making excellence a habit.™

EC Production Quality Assurance Certificate

This is to certify that:

FirePro Systems Limited
6 Koumandarias & Spyrou Araouzou Street
Tonia Court No2, 6th Floor
Limassol 3036
Cyprus

Holds Certificate Number:

BSI/MED/PC/560437

In respect of:

Annex A.1/3.46 - Equivalent fixed gas fire extinguishing systems for machinery spaces (aerosol systems)

This is to certify that BSI did undertake the relevant type approval procedures for the equipment identified above which was found to be in compliance with the Fire protection requirements of Module D of the Marine Equipment Directive (MED) 96/98/EC, as amended, last amended by Directive (2011/75/EU), subject to any conditions in the schedule attached hereto.

The applicant/manufacturer maintains and applies a quality system in accordance with the requirements of the Maritime Equipment Directive Annex B, Module D.

For and on behalf of BSI,
a Notified Body for the above Directive
(Notified Body Number 0086):

Gary Fenton, Global Assurance Director

This certificate remains valid unless cancelled, expired or revoked.

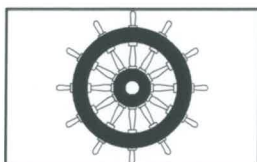

0086/yy

Notes:

The certificate authorises the manufacturer or his authorised representative established within the Community in conjunction with the EC Type Examination (Module B) certificate of the equipment listed in the scope to affix the "Mark of Conformity" (Wheelmark). This certificate loses its validity if the manufacturer makes any changes or modifications to the approved quality system, which have not been notified to, and agreed with the notified body named on this certificate and/or after lapse of time, withdrawal or revocation of the EC Type Examination (Module B) Certificate.

Example of the Application of the "Mark of conformity":

"Wheelmark" Format yy Last two digits of year mark affixed, 0086 Notified Body undertaking surveillance module.

First Issued: 20 August 2010

Latest Issue: 09 September 2013

Expiry Date: 08 September 2016



EC Production Quality Assurance Certificate

No. BSI/MED/PC/560437

Manufacturer Address: **FirePro Systems Limited**
 Ayios Athansios
 4 Falea Street
 Limassol District
 Cyprus

Product Designation	Model	Certificate No.	Issue Date	Notified Body
A.1/3.46	FP20S, FP20SE, FP40S, FP80S, FP100S, FP200S, FP500S, FP1200, FP1200S, FP2000, FP2000S, FP3000, FP3000S, FP5700 & FP5700s aerosol generating fire extinguishing system unit with dry condensed extinguishing agent, Fire Rating Type A & B	BSI/MED/A.1/3.46/560436	09/09/2013	0086

Conditions of Certification

- i) This BSI/MED/PC/560437 issue 4 certificate remains valid unless cancelled or revoked, provided the conditions listed below are complied with and the equipment remains satisfactory in service
- ii) The equipments detailed above are to be manufactured in accordance with Production Quality Assurance system (Module D) of the Marine Equipment Directive.
- iii) If the specified standards are amended during the validity of this certificate, the product type are to be re-approved prior to it being supplied to vessels to which the amended standards apply.
- iv) Production tests are to be conducted in accordance with the applicable requirements of the Directive and be recorded by the manufacturer in accordance with the approved Production Quality Assurance system (Module D) of the Marine Equipment Directive.
- v) Each equipment is to have the "Mark of Conformity" affixed and be issued with a "Declaration of Conformity".

First Issued: 20 August 2010

Latest Issue: 09 September 2013

Expiry Date: 08 September 2016

Information-, Instruction- and User manual FS4Y Marine Panel

Version : 02
Date : 01-01-2014

BUREAU VERITAS Section ...24521F...

Examined within the General Conditions of Marine Branch of BUREAU VERITAS in order to check the compliance with the applicable requirements of BV Rules for Inland Navigation Nr. 217 Nr. 529 European Directive 2006/87/EC ADN Rules / Recommendation N° 22/2013

All particulars not shown on this document are assumed to be as per the requirements of the aforesaid texts, mainly constructional details.

Antwerp, 16-Sep-2014

[Electronic document]
The plan approval office
See Letter TN/DNI/4896/NMA/R/CO/LE





- Fire safety
- Fire detection
- Fire protection
- Fire extinguishing

Keep this information, instruction and user manual for future use. This manual lapses when revised. The latest version is obtainable from Fire Safety 4 You. This information, instruction and user manual is part of the ASP (Aerosol Standard Procedure).

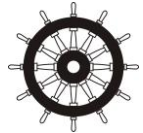

Information, instruction and user manual

Version-02 / date 01-01-2014

Copyright®

All rights reserved. No part of this publication may be reproduced and/or published by print, photo print, microfilm or any other means without the prior permission of Fire Safety 4 You B.V.

If this manual is published under order, see the General Terms and Conditions of Fire Safety 4 You B.V. or the relevant agreement concluded between the parties to this effect for the rights and obligations of customer and contractor. This manual may be given to directly interested parties for perusal.

© 2014 Fire Safety 4 You B.V.

The quality system of Fire Safety 4 You B.V. is accordance with ISO 9001:2008 / BRL-K23003.

Fire Safety 4 You B.V.®

Marine Panel for activation of FirePro fire extinguishing systems in machinery spaces and pump rooms.



This Marine Panel is patented.

Before you start.

This instruction is a supplement to the FirePro Information-, Instruction- and User manual. This Information, Instruction and User manual is part of the ASP (**Aerosol Standard Procedure**). For proper installation of the marine panel, the user of this supplement needs to take note of the Information-, Instruction- and User manual. All instructions in this supplement as well as the Information-, Instruction- and User manual need to be followed accurately.

Table of contents

Section	Subject	Page
1.0	Marine Panel IMO up to 84	3
2.0	Display Marine Panel	3
3.0	Connections of the Marine Panel	3
	3.1 Remote control box	3
	3.2 Potential free contacts	3
	3.3 Power supply	4
	3.4 Remote connection for the signal horn and flash light	4
4.0	Amount of extinguishers.....	4
5.0	Alarm on display	5
	5.1 Short circuit	5
	5.2 Open circuit.....	6
	5.3 Main supply	6
	5.4 Emergency supply.....	6
	5.5 In case of fire	6
	5.6 Main menu MF-20	7
6.0	Activating the fire extinguishers.....	9
7.0	Connections in marine panel.....	9
8.0	End of line diodes	10
9.0	Sounder & Beacon.....	11
10.0	Seal	11
11.0	Induction current	12
12.0	Statement of conformity	16
13.0	Warranty, trademarks and patents	16

BUREAU VERITAS
Stamped document, refer to 1st page

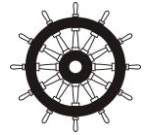

1. Marine Panel IMO – up to 84

The high quality marine panel is built to activate up to a maximum of 84 FirePro aerosol extinguishers units placed in machinery spaces and pump rooms.

The marine panel is built in a stainless steel housing with certified components and is IMO certified.

The marine panel can be ordered in different types:

- marine panel IMO-4 (to activate up to 4 extinguishing units)
- marine panel IMO-6 (to activate up to 6 extinguishing units)
- marine panel IMO-8 (to activate up to 8 extinguishing units)
- marine panel IMO-12 (to activate up to 12 extinguishing units)
- marine panel IMO-16 (to activate up to 16 extinguishing units)
- marine panel IMO-20 (to activate up to 20 extinguishing units)
- marine panel IMO-64 (to activate up to 64 extinguishing units)
- marine panel IMO-84 (to activate up to 84 extinguishing units)



This marine panel may only be installed by CATTAS (Certified Authorized Technical Technician Aërosol Systems) trained and certified persons.

2. Display Marine Panels

On every marine panel there is a display which is connected to the LOGO inside the panel. With this display you can operate the marine panel and read several features. Further on in this manual these will be explained.

To show the software version of the control box, press F1 and F4 simultaneously for 1 second.



3. Connections of the Marine Panel:

3.1. Remote control box

A remote control box (option) can be connected to the marine panel clamps (see drawing on page 10). The remote control box has the same functionality as the buttons on the marine panel.



3.2. Potential free contacts

The marine panel has 2 potential free contacts that can be connected to the XS4 clamps. Both contacts are normally closed contacts. The first potential free contact is for the incoming power supplies. If one of the two supplies is missing, the contact will be open. The second potential free contact is the error indication. If one of the following faults occurs, the contact will be open:

- main power supply missing;
- emergency power supply missing;
- short circuit in the wire of the connecting fire extinguisher;
- open circuit in the wire of the connecting fire extinguisher;
- door switch detects that the door of the marine panel is open.

If a fault occurs, the signal lamp "FAULT" and the buzzer "FAULT" will be activated. The buzzer can be reset by pressing the "RESET" button. If another fault occurs and the previous fault was reset, the buzzer will be activated again.

BUREAU VERITAS
Stamped document, refer to 1st page

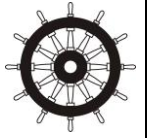

Please Note

The potential free contact cannot be reset.

3.3. Power supply

Two separate power supplies (24V) must be connected to the marine panel. A main power supply and emergency power supply are necessary for proper functioning. Wiring from the main power supply and emergency power supply to the marine panel must be flexible 2 x 2.5 mm² and fire resistant (E-30). If one of the power supplies is missing, the display will indicate this fault.

The two possible messages are:

- main power not available;
- emergency power not available.

3.4. Remote connection for the signal horn and flash light

A signal horn and flash light can be connected to the XS3 clamps (see drawing page 6). These signal devices will activate when the door of the marine panel is opened. After opening the marine panel door, the signal devices can be deactivated by pressing the "RESET" button.

4. A: SET UP NUMBER OF EXTINGUISHING UNITS LOGO ON THE DISPLAY!

Programming the amount of extinguishers.

Press the buttons F2 and F3 on the display simultaneously for at least 5 seconds. The following screen will appear:

**NUMBER OF
ACTUATORS
4
F4 BACK**

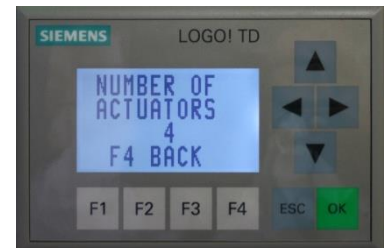

Select the amount of actuators (units) by pressing F1. When the right number is selected press F4. The display will show the voltage measurement of the connected actuators. The measured current is approximately 4mA. So the resistance nor the length of the connected cable have any influence.

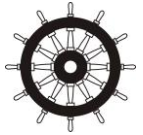

B: SET UP NUMBER OF EXTINGUISHING UNITS LOGO!

Programming the number of units connected to the LOGO! in the cupboard

Press the ESC button and hold it. Then press the (arrow left) button for 3 seconds. Release both buttons.

The screen will display the following:

**NUMBER OF
ACTUATORS
4
F4 BACK**

(the F4 back does not function now and is merely there for aesthetic reasons)

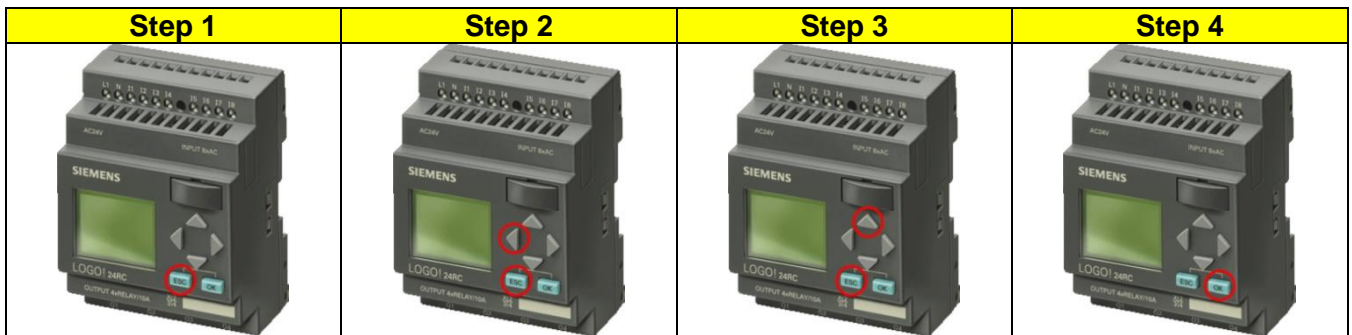

Now press the ESC button again and hold it. Press the (arrow up) button until you have reached the appropriate number of units. Finally press the OK button to finalize the installation.

After a few moments, the display will automatically show the measuring mode.

5. ALARMS ON DISPLAY

5.1 Short circuit

If there is a short circuit in the cabling of the connector the display will show the message:

**SHORT
CIRCUIT
CABLE
ACTUATOR [#]**

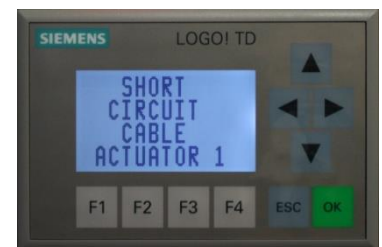

The display will also show the date and time when the problem emerged.

If this fault occurs, the signal lamp "FAULT" and the buzzer "FAULT" will activate. The buzzer can be reset by pressing the "RESET" button. If the problem is solved the message will stay on the screen until the fault is acknowledged by pressing the "OK" button. The date and time will disappear.

BUREAU VERITAS
Stamped document, refer to 1st page

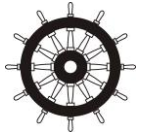

5.2 Open circuit

If there is an open circuit in the cabling of the connector the display will show the message:

**CABLE
BREAKAGE
ACTUATOR [#]
ACT. WITH OK**



The display will also show the date and time when the problem emerged. If this fault occurs, the signal lamp "FAULT" and the buzzer "FAULT" will activate. The buzzer can be reset by pressing the "RESET" button.

If the problem is solved the message will stay on the screen until the fault is acknowledged by pressing the "OK" button. The date and time will disappear.

5.3 Main supply

In case the main supply will be cut off, the display will show the message:

**MAIN SUPPLY
NOT
AVAILABLE**



5.4 Emergency supply

In case the emergency supply will be cut off, the display will show the message:

**EMERGENCY SUPPLY
NOT
AVAILABLE**



5.5 In case of fire

In case of fire, open the marine panel. The connected signal horn and flash light will be activated. After opening the marine panel door, the signal devices and the buzzer "FAULT" can be deactivated by pressing the "RESET" button.

BUREAU VERITAS
Stamped document, refer to 1st page

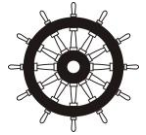

5.6 Main menu MF-20

In the main menu you can select the following items:

- F1=actuators, in this screen you can read the voltage input of the actuators.
- F2=setting act., in this screen you select the actual amount of connected actuators.
- F3=alarms, in this screen you can read out the alarm history.
- F4=setting date & time.

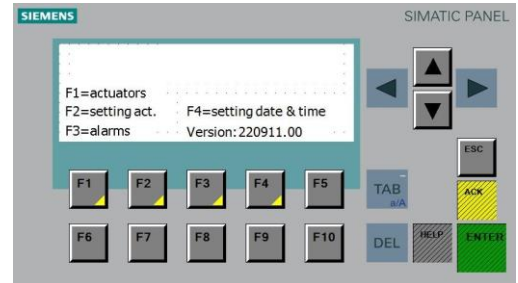

Screen “actuators”

There are three screens for reading out the voltage of the actuators. The first screen is for reading out the first eight actuators. Use the arrow buttons to scroll through the screens. In the last screen you can press the F1 button to go to the main menu.

A correctly connected actuator will give about 0.6 volt. A actuator with a short circuit will give about 0 volt. An actuator with a breakage will give more than 5 volt.

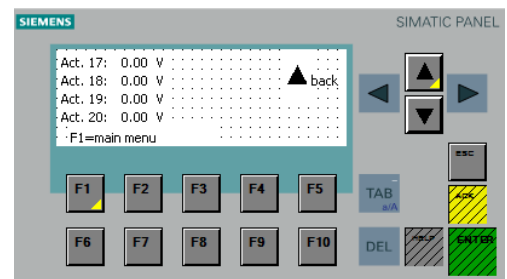
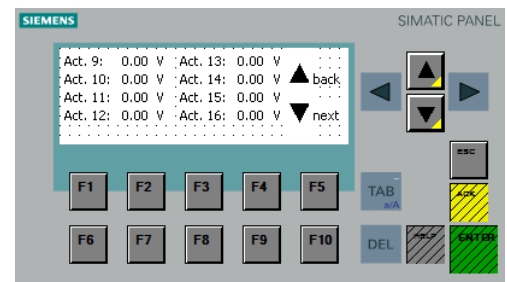
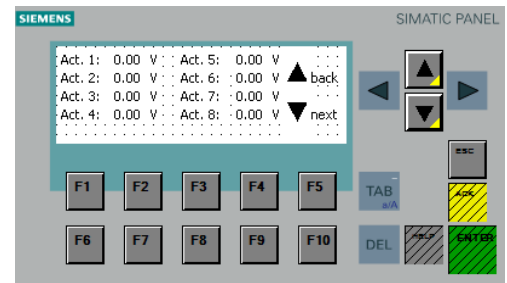

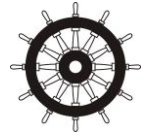

Screen “setting act.”

Select the amount of connected actuators and press the enter button.

Connect the actuators from left to right to the terminals in the switchboard.

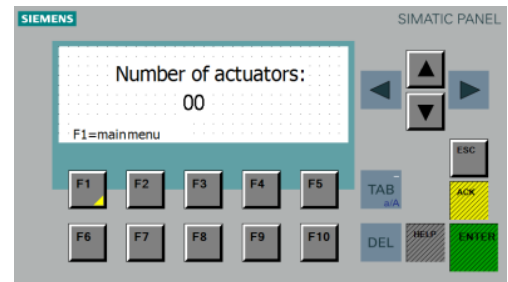

Screen “alarms”

In the screen “alarms” you can scroll through the alarm history with the arrow buttons. The alarm message of the event is displayed with the date and time.

When an alarm occurs the message will appear in the actual screen. The message will disappear when the problem is solved and will be stored in the memory of the panel.



Screen “setting date & time”

Use the arrow buttons (< and >) to go to the item you want to change. Press the enter button and a line of characters will appear. Press the enter button until the right character is reached. After a second the line of characters disappears. Use the arrow buttons to change the next item. If everything is OK, go to the “set” button with the arrow buttons and press enter. The date & time is stored in the plc and will be memorized for 20 days after a power failure. After 20 days without power you have to change the date & time.

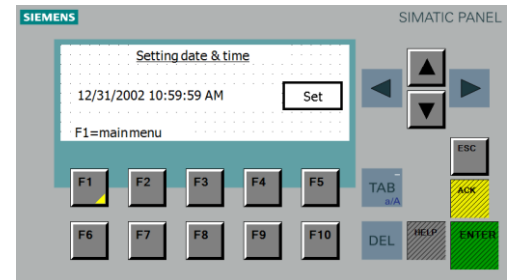

Remark:

Date is displayed as: month/day/year

Time is displayed as: hour(0-12)/minutes/seconds AM or PM

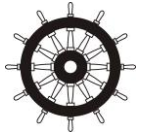

6. ACTIVATING THE FIRE EXTINGUISHERS

Follow the next steps:

1. open the door of the marine panel by turning the handle on the door a quarter to the right (clockwise);



2. break the seal on the yellow/red rotary switch (see left lower part at the inside of the marine panel);



3. turn the yellow/red rotary switch inside the marine panel to the right (clockwise);



4. the fire extinguishers will be activated.



The message will stay on the screen until the fault is acknowledged by pressing the “OK” button. The date and time will disappear.



Warning

The fire extinguishers can work only once.

After activation of the fire extinguishing system you must immediately contact your dealer or the distributor via +31 (0)186-699600 or via info@firesafety4you.com

7. CONNECTIONS INSIDE THE MARINE PANEL

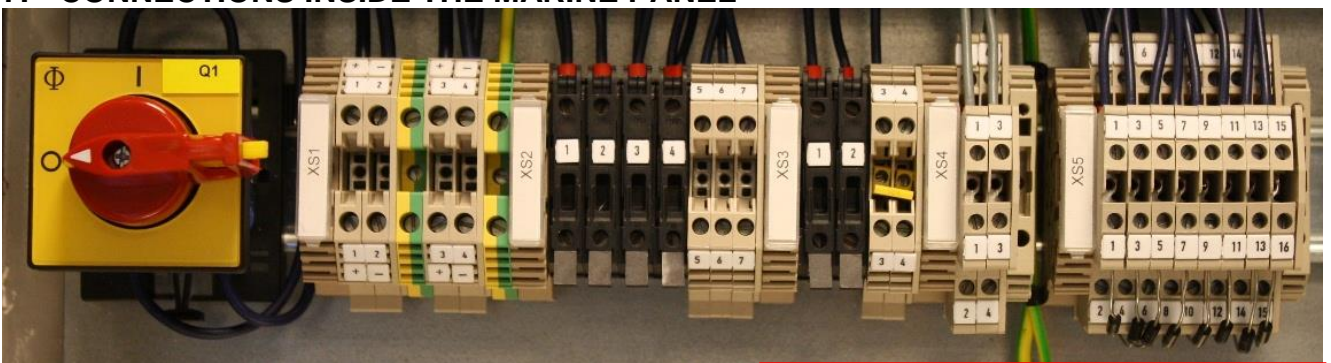

BUREAU VERITAS
Stamped document, refer to 1st page

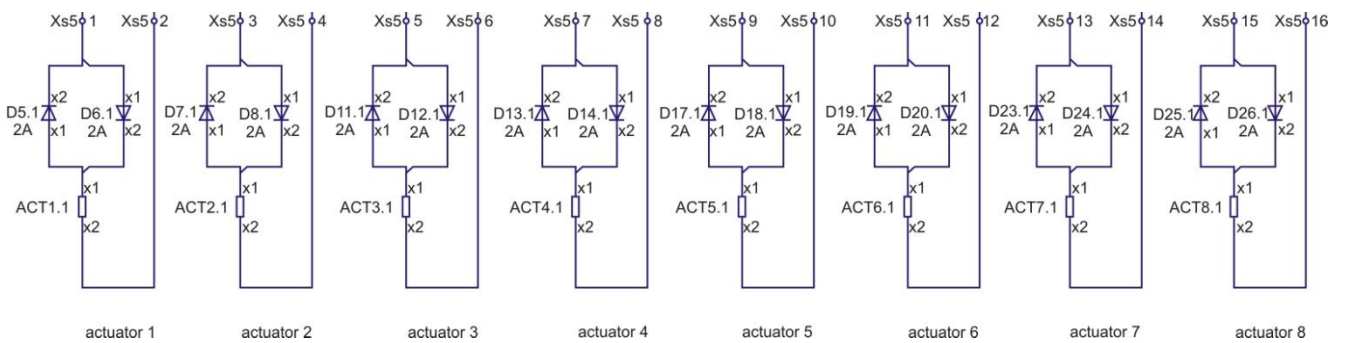
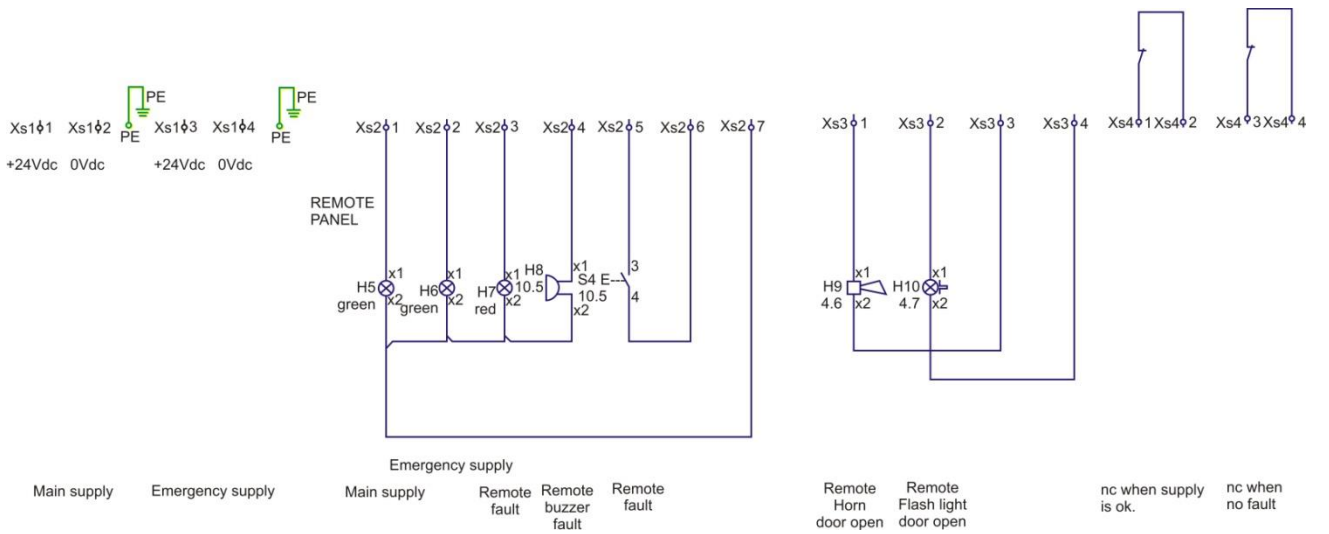
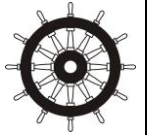

8. End of line diodes

For the correct measurement of wire break and/or short-circuit, you have to place two diodes between the end of the wire and the activator from the extinguishing unit.



Please Note

Ask your supplier whether the diodes are already installed.
Diode type: 1N5062

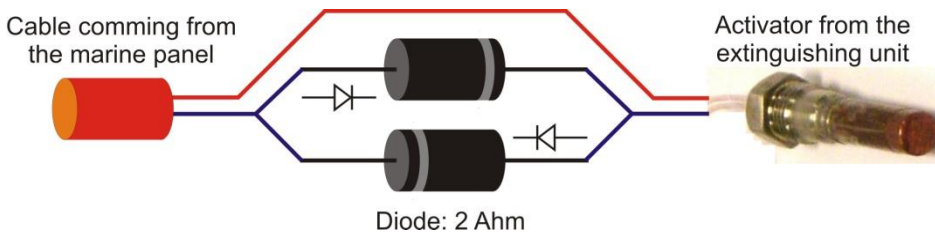

BUREAU VERITAS
Stamped document, refer to 1st page

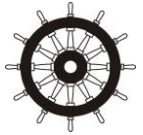

9. Sounder & Beacon

The Nexus-105 sounder & beacon is a high output, low current consumption sounder designed for industrial, fire and marine use. During the tests we did use the Nexus-105 and we recommend the Nexus-105 in combination with our marine panels. The Nexus-105 is IP66 i.e. you can install the Nexus at almost any location.



Nexus 105 dBA Industrial, Fire and Marine Sounder (Red)

- IP Rating IP66 / continuous
- Sound 105 dBA / 1m Version / 64 Tones / see tone table
- Operating Temp. -25°C to +70°C
- Weight 1.1Kg
- Quarter turn fasteners for ease of installation
- First fix, wire to base technology
- Cable Entries 5
- Volume control for greater flexibility
- Three alarm stages
- Operating Voltage 10-60V
- Compliancy EN54-3 TYPE B
- VDS Approved

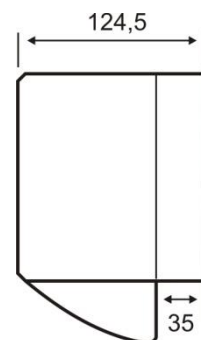
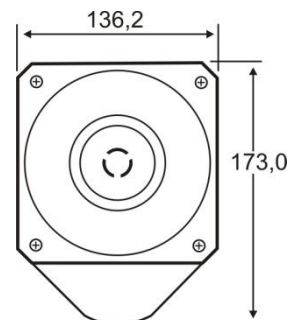

10. Seal



Please Note

Before you handover the installation, be sure that the seal is placed and the seal number is noted in the logbook.



BUREAU VERITAS
Stamped document, refer to 1st page

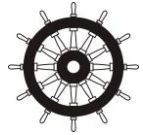

11. Induction current

Induction or stray currents can occur aboard ships. This should be taken into account when installing a fire extinguishing system that is controlled by a marine panel so that these types of currents can be prevented from having undesired effects on the system's functioning.

As the mechanisms of induction, coils and magnetic fields are not always clear, the following paragraph contains a short theoretical introduction to the phenomena. Subsequently, there is an explanation as to why they sometimes occur aboard ships, followed by practical tips and pointers concerning the cabling to prevent interference with the system from happening.

Introduction

Induction is a natural phenomenon whereby the production of an electric current across a conductor moves through a magnetic field or when the conductor is located in a changing magnetic field. If there is a magnetic field in the vicinity of the coil, a physical entity Φ (Phi) flux (magnetic current) arises. Before the magnetic field, the coil had no Φ flux. Since coils do respond well to change, the coil produces an opposite flux that neutralises the first Φ flux. As a result, there is a (induction) current across the coil. At any place where there is a current, a voltage can be measured.

Electric current is impossible without a closed circuit. So if a magnet were to be moved back and forth through the coil, there may be (induction) tension between the coil's connection points, but there will be no electric current.

Technical explanation

Background information:

Magnetic induction

Magnetic induction B indicates the strength of the magnetic field, denoted T (tesla). The magnetic induction is strongest at a magnet's poles and weakest in its centre. Magnetic induction is a vector quantity, i.e. it has a direction. This direction goes from a magnet's north pole to its south pole.

In case of an induction coil, the strength of its magnetic field depends on:

- the intensity of the electric current through the coil;
- the number of loops of the coil;
- the coil's length;
- the presence of a core in the coil.

Magnetic flux

Magnetic flux Φ is a measure for the number of magnetic field lines that run perpendicularly through a surface. Its unit is the weber (Wb). Magnetic flux can be calculated with the formula $\Phi = B_n \cdot A$, where B_n is the component of B perpendicular to the surface and A the surface in m^2 through which the field lines run perpendicularly.

In other words, the more field lines run through a certain surface, the larger the flux.

Flux change arises when:

- the number of field lines increases, e.g. because a magnet is moved closer to the surface;
- the surface itself increases, e.g. by extending, increasing the number of field lines.

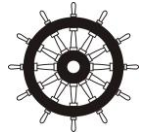

Electromotive force

The *electromotive force* V_{ind} is the electric current over the inductor's extremes that arises when the *magnetic flux* through that coil *changes*.

The adjoining illustrations show that there are few field lines running through the left coil and an increasing number through the right one. This means that if the magnet moves towards the induction coil, the flux through the coil will increase and electromotive force will be produced.

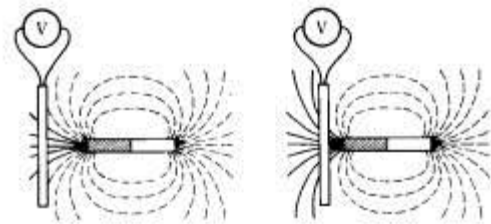

The amount of electromotive force produced can be calculated with the formula:

$$V_{ind} = N \cdot \frac{\Delta\Phi}{\Delta t}$$

where N is the coil's number of loops, $\Delta\Phi$ the change in flux and Δt the duration of the flux change.

The formula shows that there is a high electromotive force when in a coil with a large number of loops there is a large flux change in a short period of time.

Determining electromotive force with a flux/time graph.

In a graph where flux is plotted against time, the electromotive force can be found in the gradient of the line.

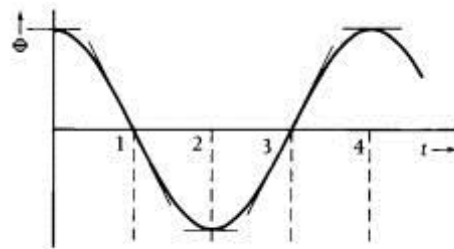

$$\frac{\Delta\Phi}{\Delta t}$$

That gradient equals $\frac{\Delta\Phi}{\Delta t}$. When the line is a curve, as in the graph above, first draw a tangent line at the point in question. Then determine the gradient of the tangent. The product of the number of loops and the tangent is the electromotive force. In the illustration above, the flux change and therefore the electromotive force are largest at points in time 1 and 3. At the points in time 0, 2 and 4 the tangent lines are horizontal, i.e. the electromotive force is zero!

Induction current

If an electric component, e.g. a light or resistance, is connected to the induction coil where electromotive force is produced, this will lead to an induction current in the inductor.

The direction of the induction current

The induction current's direction is such that it produces its own magnetic field that counteracts the change of the external flux.

BUREAU VERITAS
Stamped document, refer to 1st page

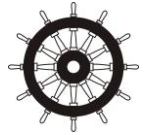

The magnet nears the induction coil, the external flux increases.

In the adjoining illustration the north pole nears the coil. Therefore, the number of field lines directed towards the top left increases. The coil will oppose the change with a current that counteracts the increase of these external field lines.

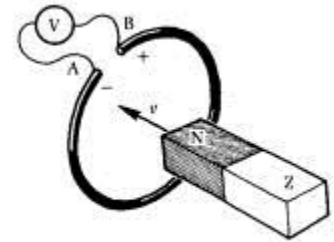

In other words, the coil makes a field that is directed towards the bottom right. According to the right-hand rule, the induction current in the coil's loop goes from A to B.

The negatively charged electrons always move against the current, so an accumulation of negative charge arises at A, i.e. A becomes this voltage source's negative pole. B becomes the positive pole and therefore has the highest potential.

NB. The coil is a voltage source in this instance; *in a voltage source*, the current always goes from *negative to positive*, **outside the voltage source** the current always goes from **positive to negative!**

The magnet moves away from the induction coil, the external flux decreases.

If the magnet is now being pulled back, the external flux directed towards the top left diminishes and the coil opposes this changes by producing filed lines towards the top left. The induction current in the coil will then go in the opposite direction from the previous situation, when the magnet neared the coil. The positive and negatives poles reverse.

Induction currents aboard ships.

Leakage and induction current occur more often aboard ships than on land, due to the fact that ships are usually made of steel and therefore mass can develop quite easily.

If an induction current develops in the electric circuit of the fire extinguishing system, this may lead to the undesired activation of that system. Provisions have been made in the design of the marine panel to prevent this from happening. The earth plate for instance, is isolated from the casing.

When installing the system, it is of the utmost importance to ensure that external induction currents cannot influence the fire extinguishing system's electric circuit. This can be realized by strictly following the cabling instructions below.

Important cabling instructions

do not place cables in loops and/or coil them up;

cut cables properly;

lead cables through swivel correctly.

Illustration 1.

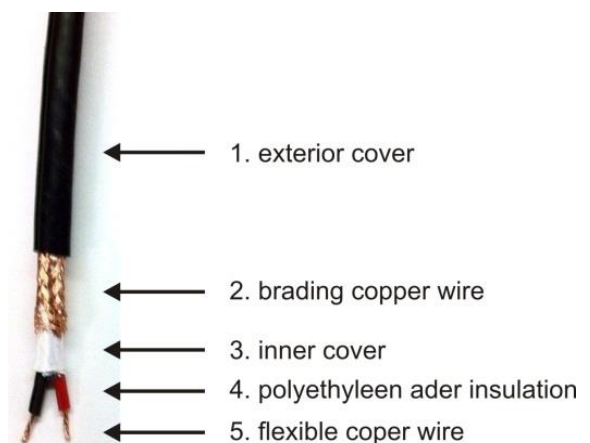

BUREAU VERITAS
Stamped document, refer to 1st page

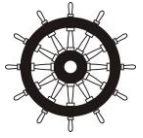

1. coiling up or looping a cable creates an induction coil. Placing the cable in straight lines prevents this.
2. when cutting the cable, it is important not to cut into the insulation in order to prevent (current) leakage.
3. When leading a cable through a swivel (illustrations 2 & 3), it is important that the braid, jacket and/or flexible copper wire (illustration 1) do not come in contact with the (metal) swivel. To ensure that, lead sufficient cable through the swivel and use a shrink sleeve for the coaxial cable.

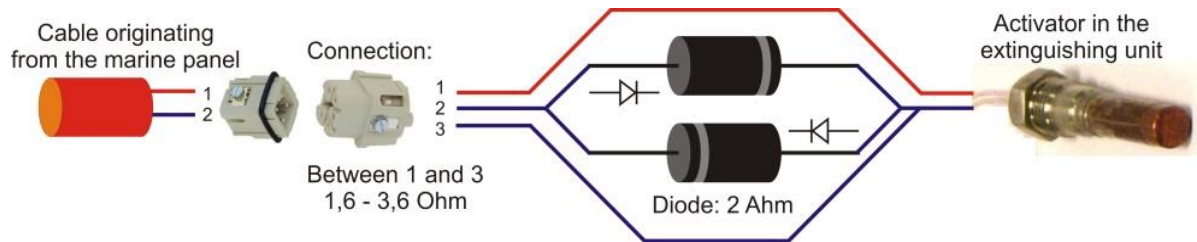

illustration 2



illustration 3

4. Make sure that the bare wire of the diodes are properly protected and cannot come in contact with the casing and/or other wiring.



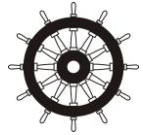

12. Statement of conformity (II-A)

We, Fire Safety 4 You B.V., herewith declare that the product Marine Panel types IMO- up to 84, where to this statement refers, is in conformity to the RS "Rules for the Classification and Construction of Sea-Going Ships" (2010) and EMC directives 89/336/EEG and BRL-23001/03 (by KIWA Nederland).

13. Warranty manufacturer

The manufacturer guarantees that the marine panel used in the installation performs consistent with the documentation, provided they are installed and maintained in accordance with these instructions.

Liability

Except in case of deliberate or conscious recklessness by the Supplier or its employees, the Supplier excludes all liability with respect to financial, consequential or other damage or loss on the User's side based on statements, guarantees (both explicit and implicit), conditions or other obligations by law. The same applies for unusual, indirect, incidental or consequential loss (including loss of profit or revenues, loss of documents or data, costs of substitute products, damage to reputation or goodwill, or any other matter that can reasonably be expected to be outside the Supplier's power).

Trademarks

Fire Safety 4 You®, FS4Y Marine Panel® and FirePro® are registered trademarks. All other company or product names are trademarks, registered trademarks or service brands of their respective owners.

Patents

FS4Y Marine Panel and FirePro® are registered patents. Legal action will be taken against violations of these patents, by whichever name.

Information on guidelines / European guidelines

Products with the CE-mark mentioned in this manual and in the Information-, Instruction- and User manual comply with both the guideline for stationary extinguishing components on dry aerosol basis (EMC directives 89/336/EEG) and the BRL-K23001. The accredited institute KIWA NV has certified FirePro® in accordance with this BRL (Assessment guideline).

Authors : Fire Safety 4 You B.V. (Mr. R.G.C. Reijns)
Sundermann Elektrotechniek (Mr. R.A. Sundermann)

Basis : International Maritime Organisation, KIWA, TNO, KEMA

Publisher : Fire Safety 4 You B.V.
Koudenberg 5
4651 JR Steenberg NB
Telephone : +31 (0)186-699600
Home page: www.firesafety4you.com
Email : info@firesafety4you.com

Layout : Conforms to NEN-5509

BUREAU VERITAS
Stamped document, refer to 1st page

Calculation method in conformity of the manufacturer / MED - 120 gram m3

Date of calculation	01-4-2014
---------------------	-----------

Certified supplier	IGVAB
Address	Landsteinerlaan 46
ZIP code	9728KC
Place	Groningen
Country	Nederland
Contact person	Wobbe Groefsema
Telephone number	06-37303499
E-mail address	vusu02gd@kpnmail.nl

Name client	Chemgas Barging S.a.r.l.
Address	53, Avenue Pasteur
ZIP code	L-2311
Place	Luxembourg
Country	Luxembourg
Contact person	dhr. Tieman Zoer
Telephone number	
E-mail address	

Calculation effective amount per m³ in grams

Ship name/no.	Sirocco
---------------	---------

Safety factor IMO (NOT REQUIRED)	1
----------------------------------	---

NOTE! For wooden ships use a safety factor of 1,17

Room name/no.		Engineerium									
To protect m³		Length	299,7	Width	1	Height	1	m³	299,70		
Fire Class / m³		A & E	120	B	120	C	120	F	120		
Total effect. per m³		A & E	120	B	120	C	120	F	120		
Amount of grams		A & E	35.964,00	B	35.964,00	C	35.964,00	F	35.964,00		
Type unit	FP-20	FP-40	FP-80	FP-100	FP-200	FP-500	FP-1200	FP-2000	FP-3000	FP-5700	Amount in gram
Effective ext. agent per unit	12,0	24,4	47,2	61,0	118,0	330,0	756,0	1.200,0	1.830,0	3.363,0	
Number of units, Class A&E	2997,0	1473,9	761,9	589,6	304,8	109,0	47,6	30,0	19,7	10,7	1.029,0
Number of units, Class B	2997,0	1473,9	761,9	589,6	304,8	109,0	47,6	30,0	19,7	10,7	1.029,0
Number of units, Class C	2997,0	1473,9	761,9	589,6	304,8	109,0	47,6	30,0	19,7	10,7	1.029,0
Number of units, Class F	2997,0	1473,9	761,9	589,6	304,8	109,0	47,6	30,0	19,7	10,7	1.029,0
Number of units Design										11	

Room name/no.		Bowthruster									
To protect m³		Length	104,4	Width	1	Height	1	m³	104,40		
Fire Class / m³		A & E	120	B	120	C	120	F	120		
Total effect. per m³		A & E	120,00	B	120	C	120	F	120		
Amount of grams		A & E	12.528,00	B	12.528,00	C	12.528,00	F	12.528,00		
Type unit	FP-20	FP-40	FP-80	FP-100	FP-200	FP-500	FP-1200	FP-2000	FP-3000	FP-5700	Amount in gram
Effective ext. agent per unit	12,0	24,4	47,2	61,0	118,0	330,0	756,0	1.200,0	1.830,0	3.363,0	
Number of units, Class A&E	1044,0	513,4	265,4	205,4	106,2	38,0	16,6	10,4	6,8	3,7	924,0
Number of units, Class B	1044,0	513,4	265,4	205,4	106,2	38,0	16,6	10,4	6,8	3,7	924,0
Number of units, Class C	1044,0	513,4	265,4	205,4	106,2	38,0	16,6	10,4	6,8	3,7	924,0
Number of units, Class F	1044,0	513,4	265,4	205,4	106,2	38,0	16,6	10,4	6,8	3,7	924,0
Number of units Design										4	

Room name/no.											
To protect m³		Length		Width		Height		m³	0,00		
Fire Class / m³		A & E	120	B	120	C	120	F	120		
Total effect. per m³		A & E	120,00	B	120	C	120	F	120		
Amount of grams		A & E	0,00	B	0,00	C	0,00	F	0,00		
Type unit	FP-20	FP-40	FP-80	FP-100	FP-200	FP-500	FP-1200	FP-2000	FP-3000	FP-5700	Amount in gram
Effective ext. agent per unit	12,0	24,4	47,2	61,0	118,0	330,0	756,0	1.200,0	1.830,0	3.363,0	
Number of units, Class A&E	0,0	0,0	0,0	0,0	0,0	0,0	0,0	0,0	0,0	0,0	0,0
Number of units, Class B	0,0	0,0	0,0	0,0	0,0	0,0	0,0	0,0	0,0	0,0	0,0
Number of units, Class C	0,0	0,0	0,0	0,0	0,0	0,0	0,0	0,0	0,0	0,0	0,0
Number of units, Class F	0,0	0,0	0,0	0,0	0,0	0,0	0,0	0,0	0,0	0,0	0,0
Number of units Design											

Room name/no.											
To protect m³		Length		Width		Height		m³	0,00		
Fire Class / m³		A & E	120	B	120	C	120	F	120		
Total effect. per m³		A & E	120,00	B	120	C	120	F	120		
Amount of grams		A & E	0,00	B	0,00	C	0,00	F	0,00		
Type unit	FP-20	FP-40	FP-80	FP-100	FP-200	FP-500	FP-1200	FP-2000	FP-3000	FP-5700	Amount in gram
Effective ext. agent per unit	12,0	24,4	47,2	61,0	118,0	330,0	756,0	1.200,0	1.830,0	3.363,0	
Number of units, Class A&E	0,0	0,0	0,0	0,0	0,0	0,0	0,0	0,0	0,0	0,0	0,0
Number of units, Class B	0,0	0,0	0,0	0,0	0,0	0,0	0,0	0,0	0,0	0,0	0,0
Number of units, Class C	0,0	0,0	0,0	0,0	0,0	0,0	0,0	0,0	0,0	0,0	0,0
Number of units, Class F	0,0	0,0	0,0	0,0	0,0	0,0	0,0	0,0	0,0	0,0	0,0
Number of units Design											

Type unit	FP-20	FP-40	FP-80	FP-100	FP-200	FP-500	FP-1200	FP-2000	FP-3000	FP-5700
Total Number of units	0	0	0	0	0	0	0	0	0	15

BUREAU VERITAS Section ...24521F..

Examined within the General Conditions of Marine
 Branch of BUREAU VERITAS in order to check the
 compliance with the applicable requirements of
 BV Rules for Inland Navigation NR 217 NR 529
 European Directive 2006/87/EC
 ADN Rules / Recommendation N° 22/2013

All particulars not shown on this document are assumed
 to be as per the requirements of the aforesaid texts,
 mainly constructional details.
 The examination of this document gives rise to remarks
 in red.

Antwerp, 16-Sep-2014

[Electronic document]
 The plan approval office
 See Letter TN/DNI/4896/NMA/RCOLLE

DROGE AEROSOL BLUSSER

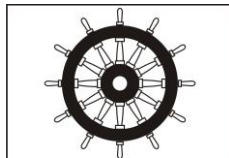

0086/10

BUREAU VERITAS Section ...24521F..

Examined within the General Conditions of Marine Branch of BUREAU VERITAS in order to check the compliance with the applicable requirements of BV Rules for Inland Navigation NR217/ NR 529 European Directive 2006/87/EC ADN Rules / Recommendation N° 22/2013 All particulars not shown on this document are assumed to be as per the requirements of the aforesaid texts, mainly constructional details. The examination of this document gives rise to remarks in red.

Antwerp, 16-Sep-2014

[Electronic document]
The plan approval office
See Letter TN/DNI/4896/NMA/RCO/LLE



TECHNISCHE INFORMATIE	
Model	FP-5700 / RVS
Type	Cold
Activeringsmechanisme	thermische activering door thermokoord elektrisch (6-32V D/C 0,8A in 3-4 seconden)
Activering	verwarmingselement 2,3 Ohm weerstand
Te testen stroomsterkte	maximaal 5 mA.
Gewicht Bruto	26.400 gram
Gewicht Bruto blusstof	5.700 gram
Gewicht Netto blusstof	3.363 gram effectief
Operationele uitstroom tijd	15-20 seconden
Uitstroom opening	1
Uitstoot lengte	8 m
Afmeting	300 mm x 300 mm x 300 mm
Brandklasse	A, B, C, F

TOEPASBAARHEID PER UNIT IN m ³ INCL. VEILIGHEIDSFACITOR 1,3	
Brandklasse A & E	46,84
Brandklasse B	49,75
Brandklasse C	86,23
Brandklasse F	34,04

TOEPASSINGEN	
Ruimten	< winkels, kantoor, musea
Vervoer	< scheepvaart, trein, container, vrachtwagen
Opslag	< magazijn, archief, loods
Mechanische ruimten	< machinekamer
Industrie	< technische ruimten, diverse

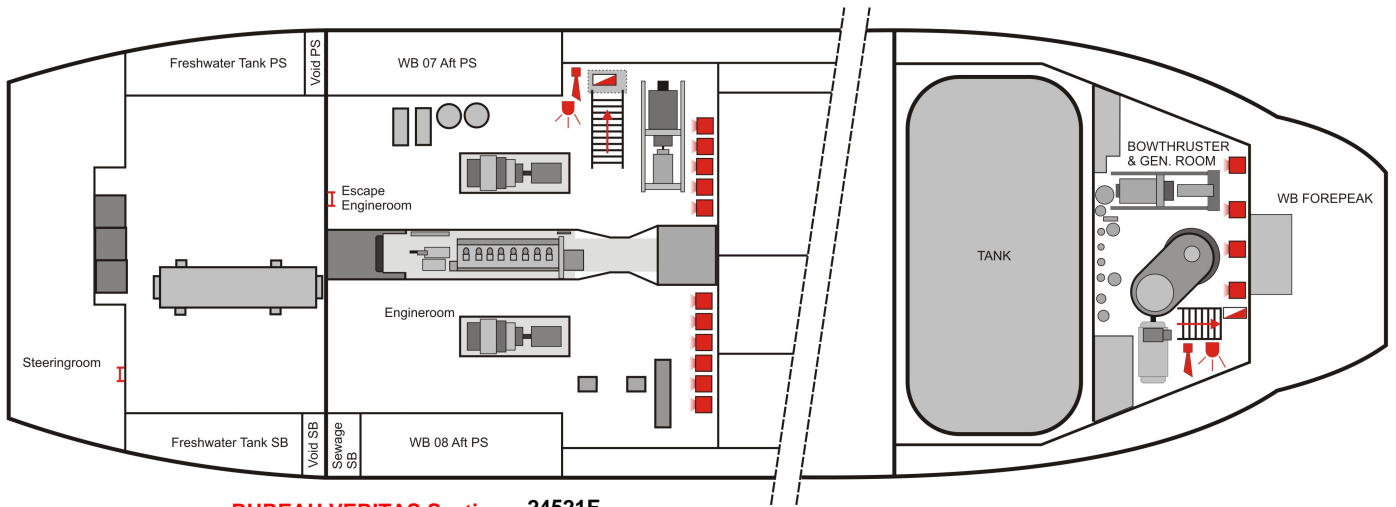

BUREAU VERITAS Section ...24521F..
 Examined within the General Conditions of Marine
 Branch of BUREAU VERITAS in order to check the
 compliance with the applicable requirements of
 BV Rules for Inland Navigation NR 217, NR 529
 European Directive 2006/87/EC
 ADN Rules/ Recommendation n°22/2013





*All particulars not shown on this document are assumed
 to be as per the requirements of the aforesaid texts,
 mainly constructional details.
 The examination of this document gives rise to remarks
 in red.*

Antwerp, 16-Sep-2014

[Electronic document]
 The plan approval office
 See Letter TN/DNI/4896/NMA/RCO/LE

© Copyright

FS4Y - LEGENDA

-  FirePro FP-5700 S
-  ONTRUIMINGSSIGNAAL
SLOW-WOOP
-  FLITSLICHT
-  MARINE PANEL
(buiten de ruimte)

 Fire safety 4 you Fire safety	Owner Chemgas Barging S.à.r.l. 53, Avenue Pasteur L-2311 Luxembourg	Introduction Fire Safety 4 You B.V. Nieuwstraat 24 3267AR Goudswaard
	Project : Ship Sirocco File : FS4Y-Sirocco-01 Engine room : 299,7 m ³ Bowthruster : 104,4 m ³ Department : brandveiligheid Date : 01-04-2014 Author : R.G.C. Reijns	