

2 Methods for improving road signs / symbols / text to adapt to today's driver's requirements

Stefan Egger, IIIDre

Stefan Egger

Information designer, researcher, speaker

Research projects on road signs/signals

2 international EU funded (3 years each):
SOMS/In-Safety, Safeway2school

7 x Conference co-organizer

Traffic & Transport Information Systems

Member working group AASTB10 of FSV

Recognised Austrian body to develop road signs

Information Design

Enable informed decision making to carry out actions and meet set goals

Definitions for graphical components

Traffic sign



Image carrier

Signal aspect

Signal aspect

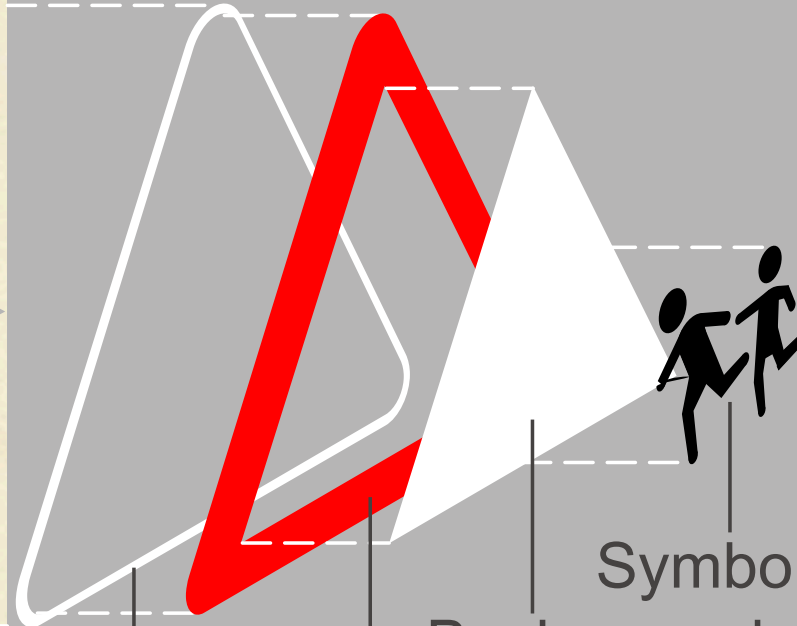

Contrast edge

Border

Background

Symbol

Symbol



Figure

Figure

Figure

(E)lements:

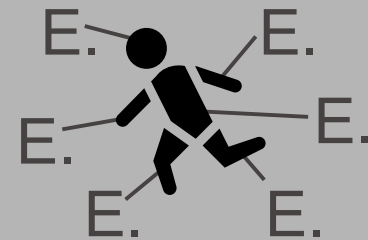

Why improve road signs?

Since road signs were "defined", the road environment has changed dramatically.

Increasing cognitive stress is burdened upon drivers.

Why improve? / 1

Increase in speed – 1968 and before: Few cars and roads to maintain speeds of more than 100 km/h

Increase in traffic volume – e.g. Austria: 143.000 cars in 1955 to 4.205.000 in 2006

Increase in network density – No or few motorways in many countries in 1955 .
E.g. Austria: 1955– 27.6 km; end 2007– 1.696 km

Why improve? / 2

Increase of long-distance travel due to interconnected road networks and suitable cars

Increase of amount of information provided on / alongside roads

**To reduce the increased cognitive load,
– and increase road safety –
Road signs should be adjusted to human
capabilities.**

Opportunities for improvement

* ISO 9186 Test procedures *
fostering understanding of visual information

* MOA Design Method *
improving visibility

- Reducing uncertainty while transforming information into action
- Earlier recognition and driving action

Improving understanding

ISO 9186 Procedures for the development and testing of graphical symbols

Improving understanding / 1

Two psychological test methods

Comprehensibility judgement test
to sort out less appropriate symbols

and

Comprehension test
measuring “understandability” of symbols

Test requirements

- Extensive research for- and collection of symbols on international level
- Symbols to be brought to same visual quality level before testing*
- 50 respondents from 3 different cultures
- Carried out with paper and pencil, monitored (to allow questions and improvement of symbols)

* *See MOA Design Method*

Comprehensibility judgement test

- To identify the most promising symbols
- omit others
- find 1st indications for further development

Improving understanding / 4

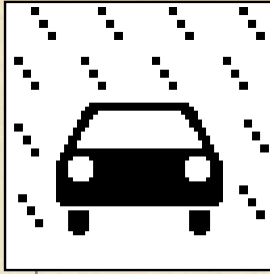

%

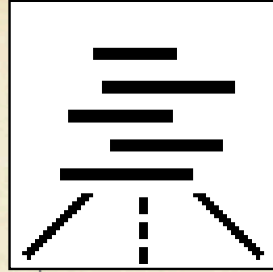

%

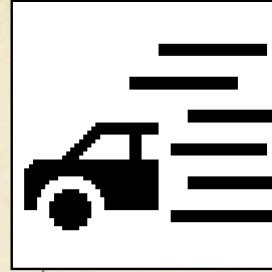

%

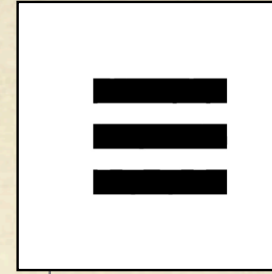

%

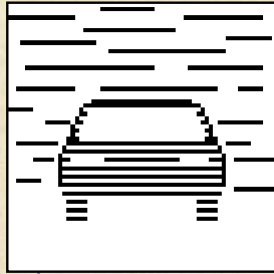

%

CJT

Fog (ahead)

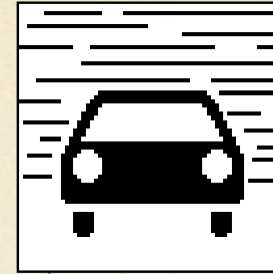

%

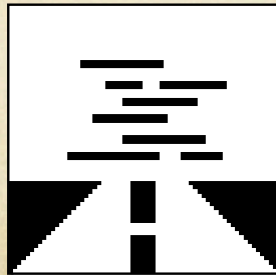

%

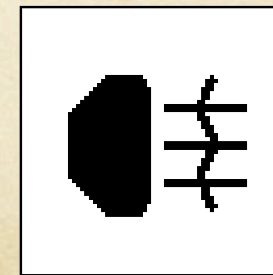

%

Improving understanding / 5

Comprehensibility judgement test

“In your opinion, what is the percentage of drivers in your country to understand the symbol?”

Then ask for reasons, taking notes.

After accumulation of results [country wise and total], symbols to reach a decided benchmark are accepted for further visual development* and the next test.

** See MOA Design Method*

Comprehension test

- Establishing an understandability score for each symbol
- Identifying the best symbol
- Poss. final indications for improvement

Improving understanding / 7

Date:

Location:

Conducted by:

Age of respondent:

Driving experience:

Kilometers per year:

Female Male

Education: Primary school
 Secondary school
 University

On each page of this booklet is a traffic symbol.

Study each traffic symbol and write down below the symbol what you think that symbol means.

If possible, also write down what you would do if you saw this symbol.

Write down “Don’t know” if you are unable to assign a meaning to the symbol.

An example is given overleaf.

This is an example:



.....
Construct
.....

Comprehension test

"What is the meaning of this symbol? And how would you react as driver when seeing it?"

Take notes..

CT

After accumulation of results [country wise and total], symbols to reach a decided benchmark are accepted for final visual development* and standardisation.

** See MOA Design Method*

MOA Design Method

Maximum resilience of a visual signal by
minimizing loss of contrast during transmission

or

It's all about maintaining contrast
in every detail

Definitions for graphical components

Traffic sign



Image carrier

Signal aspect

Signal aspect

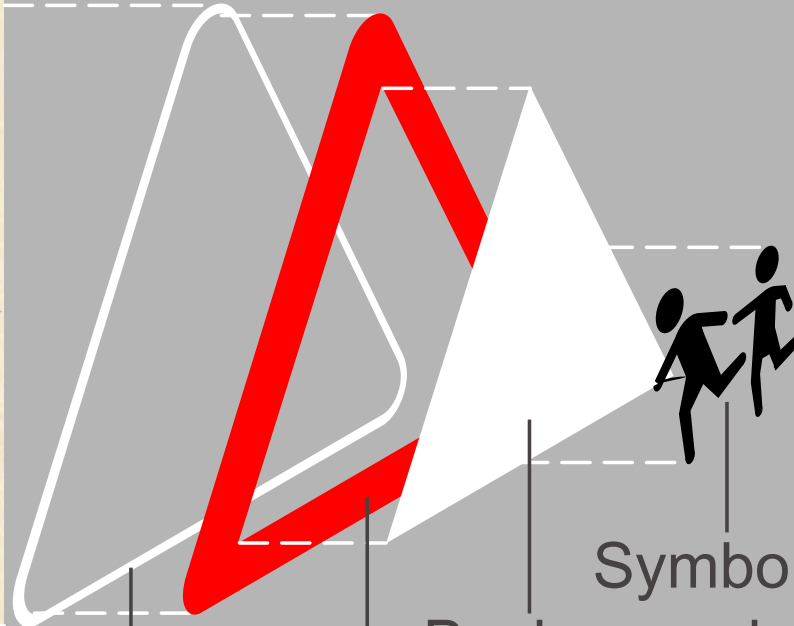

Contrast edge

Border

Background

Symbol

Symbol



Figure
Figure

Figure

(E)lements:

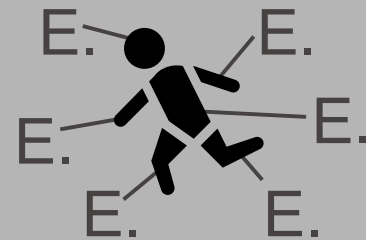

MOA Design Method / 1

Every detail of any graphical element is made to be visually discerned (discriminable) over a precisely calculable viewing distance.

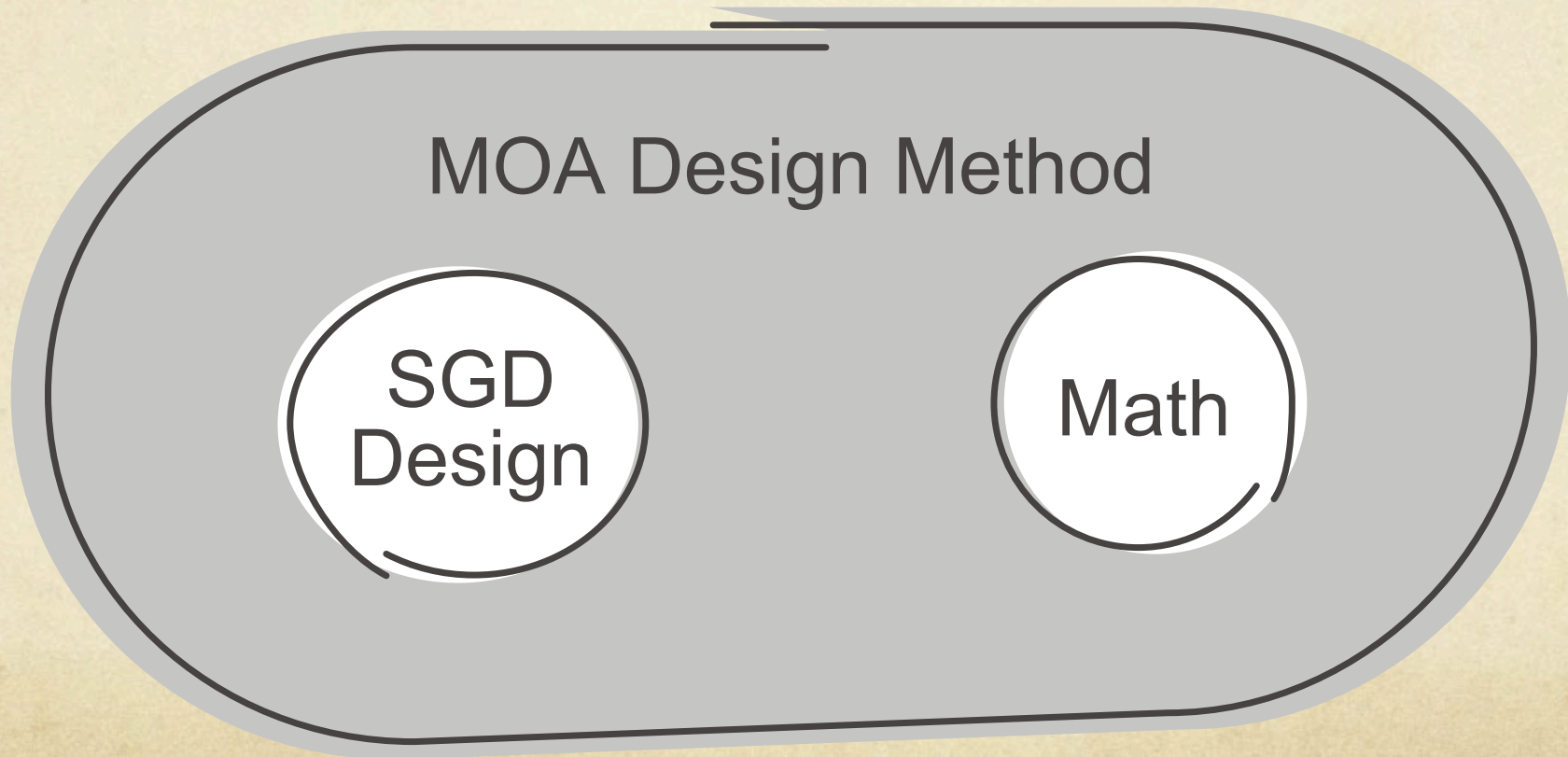

Contrast-Transfer-Function Siemens-Star

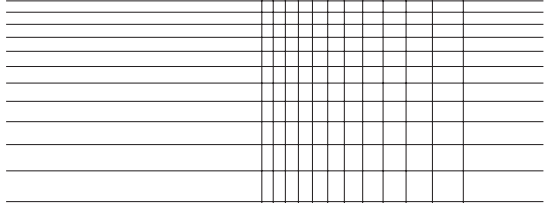
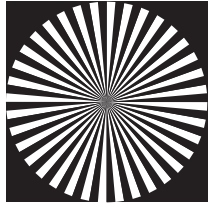
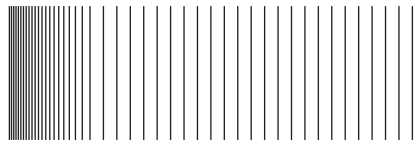
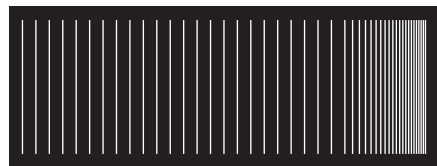
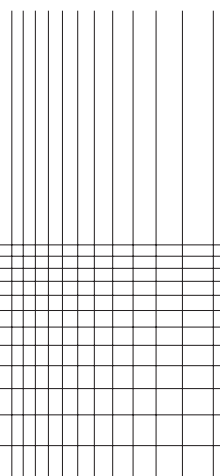
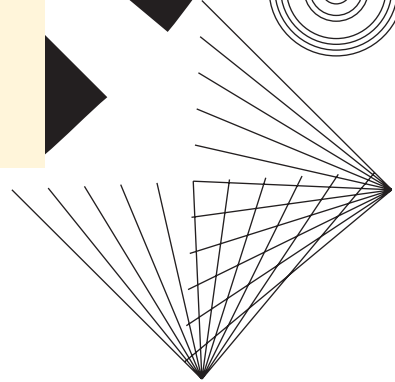
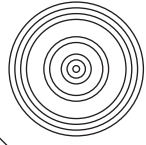
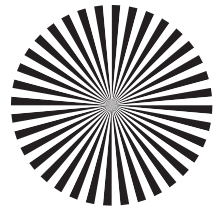
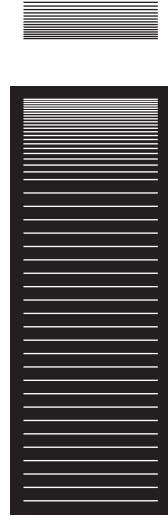
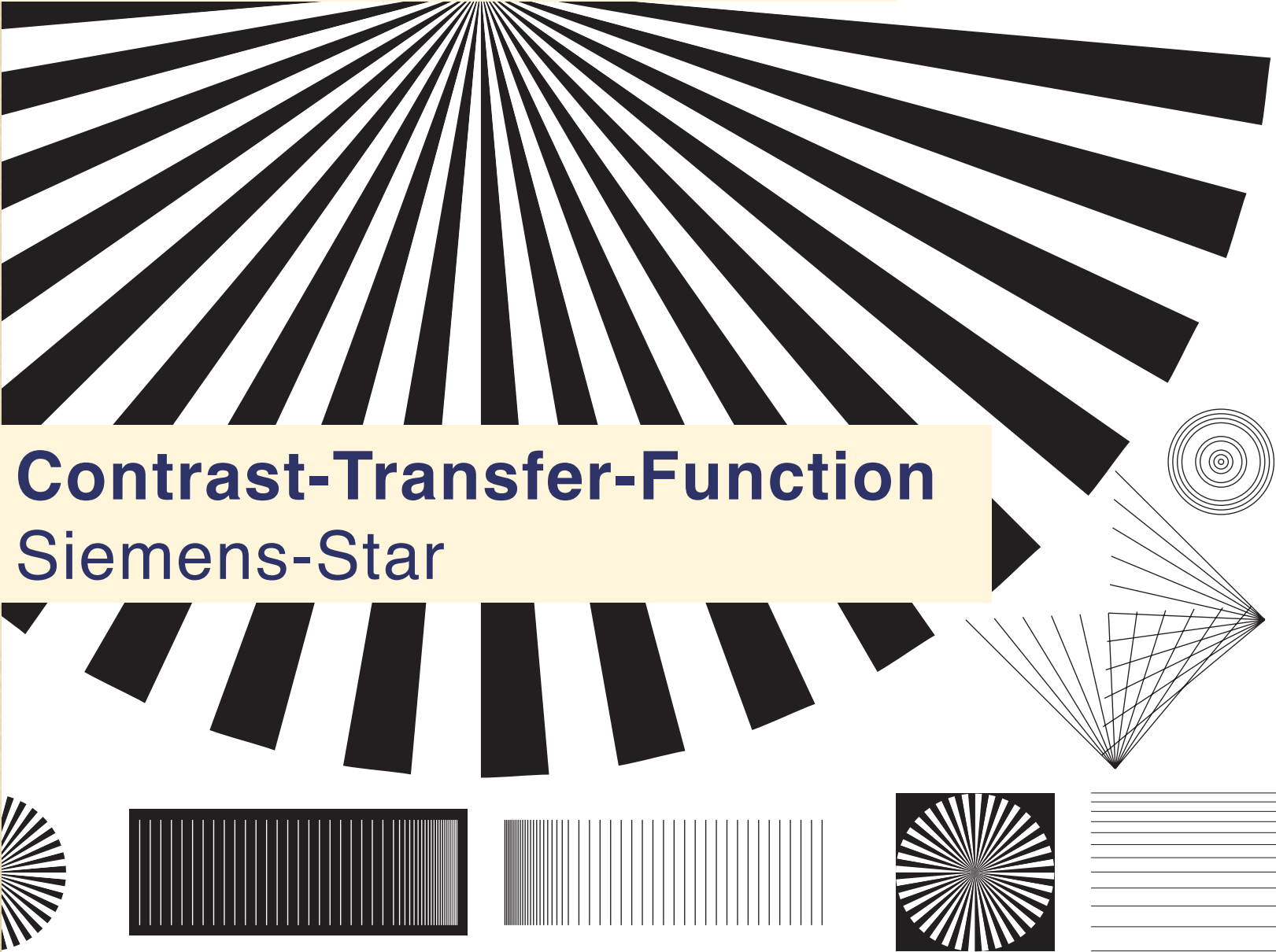

ng durch Dritte ausgeschlossen. Benutzung auf eigene Gefahr und Risiko.
rohibited. This Test ist provided "as is". Use it on your own Risk.

MOA Design Method / 3

Design according to Smallest Graphical Detail

SGD Design

providing full (100%) discriminability

= Contrast-Transfer-Function is at maximum

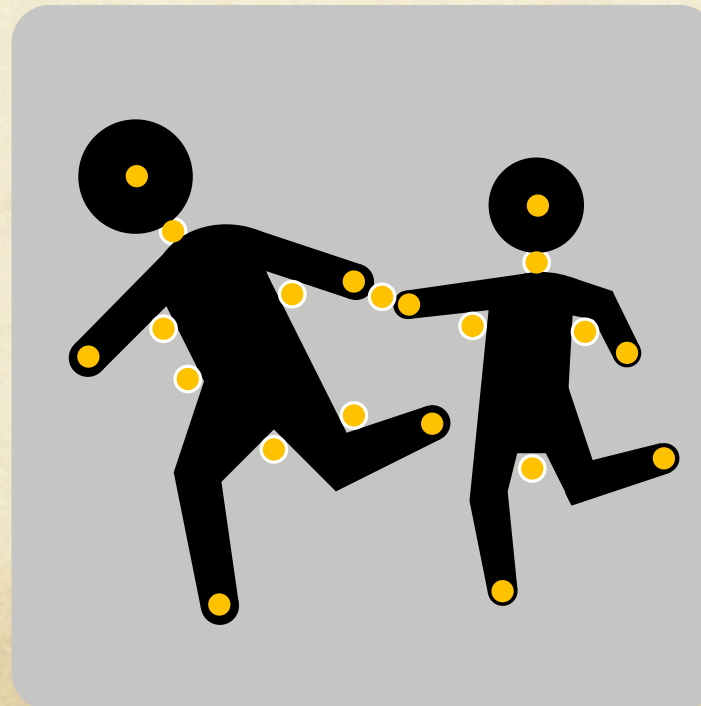

● = SGD

MOA Design Method / 4

MOA Math: Calculation of discriminability

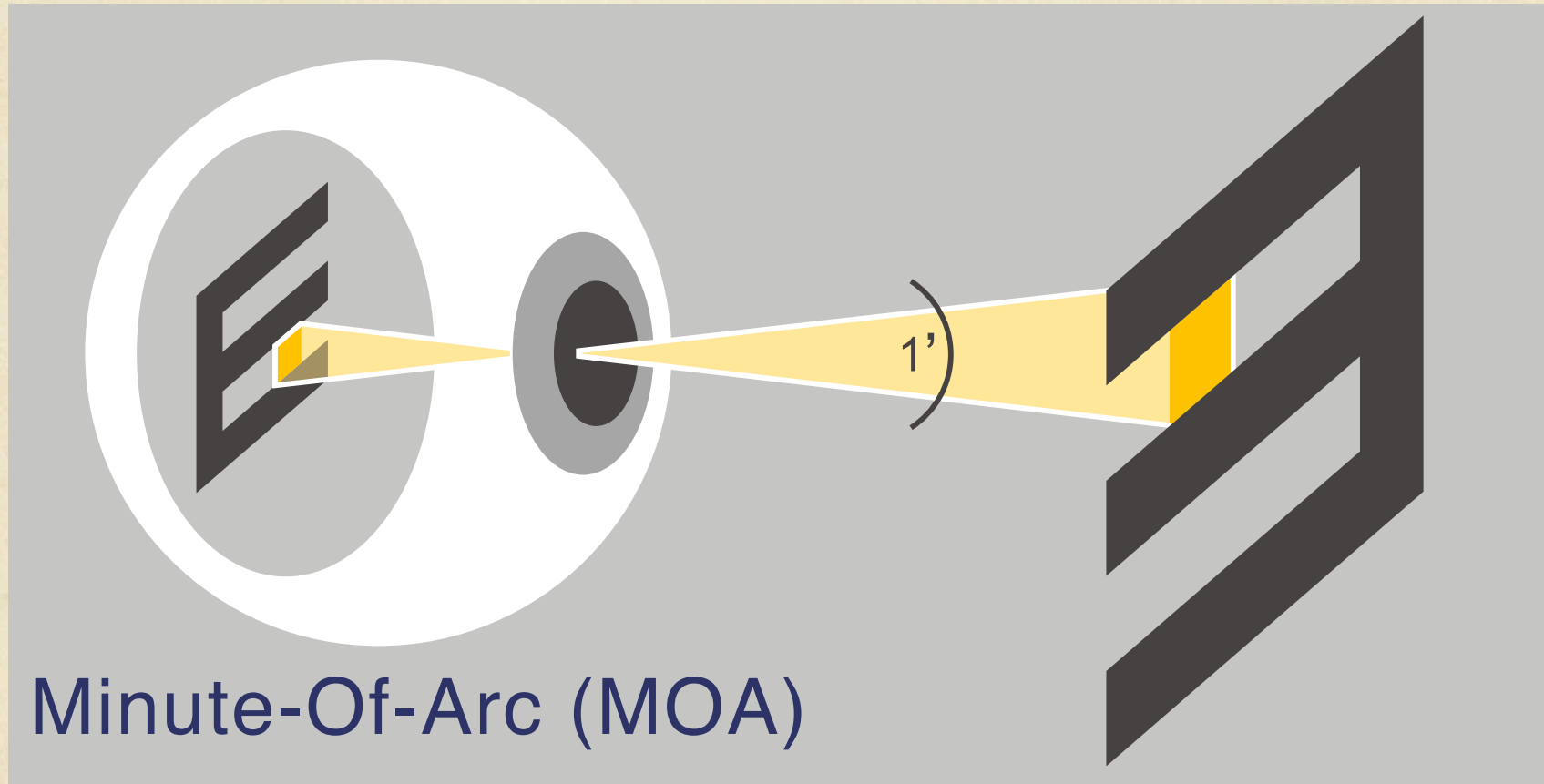

SGD dimension, viewing-distance & time, max. speed, min. visus etc.

MOA Design Method / 5

Calculability of discriminability

MOA \Rightarrow SGD

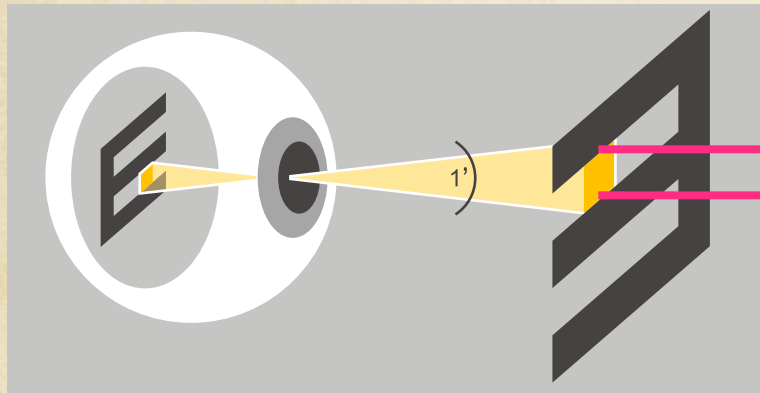

SGD \Rightarrow MOA

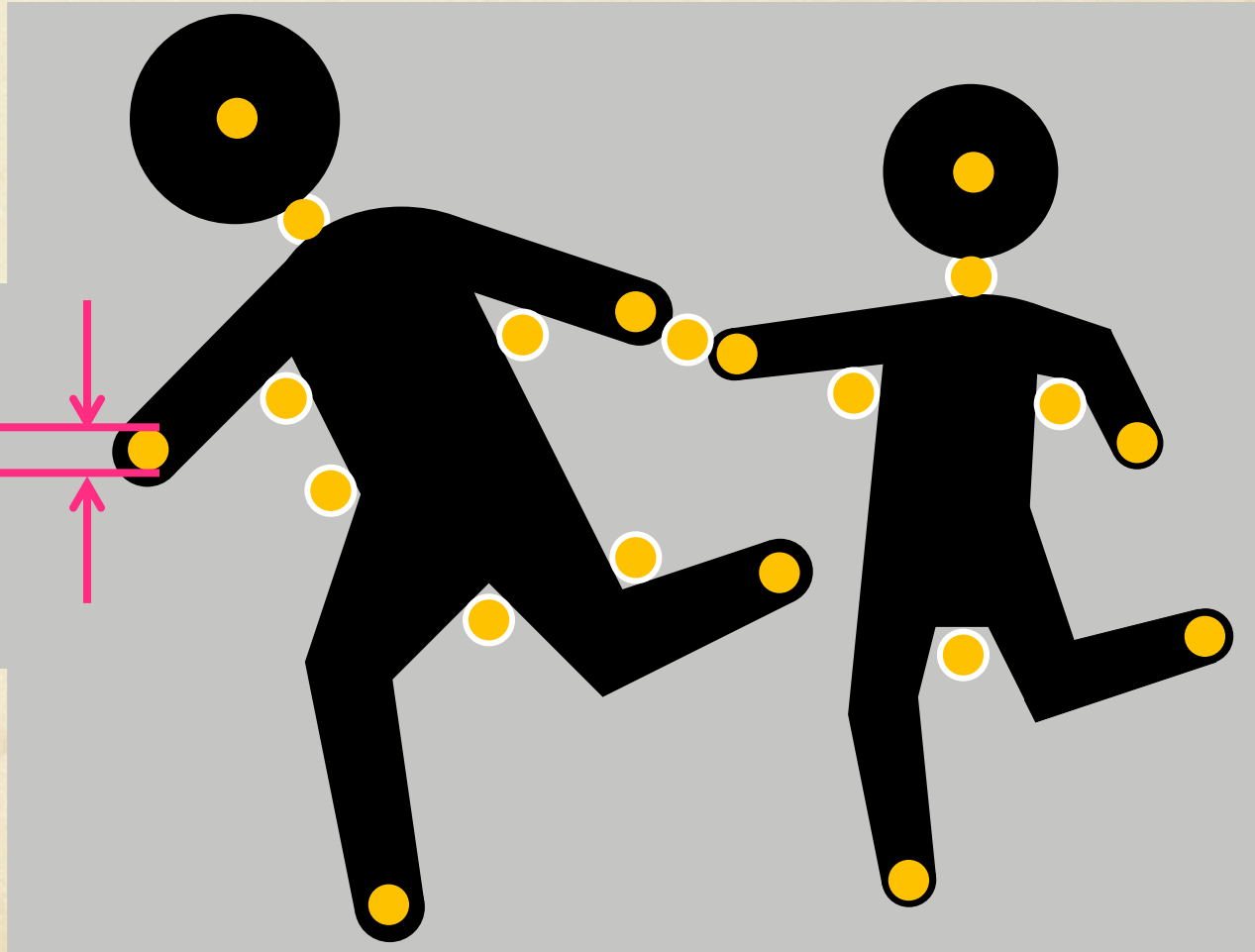

MOA Design Method / 6

MOA Design Method



UNECE ITC



Viewing distance:

100%

max. 74%

MOA Design Method / 7

Comparison of discriminability

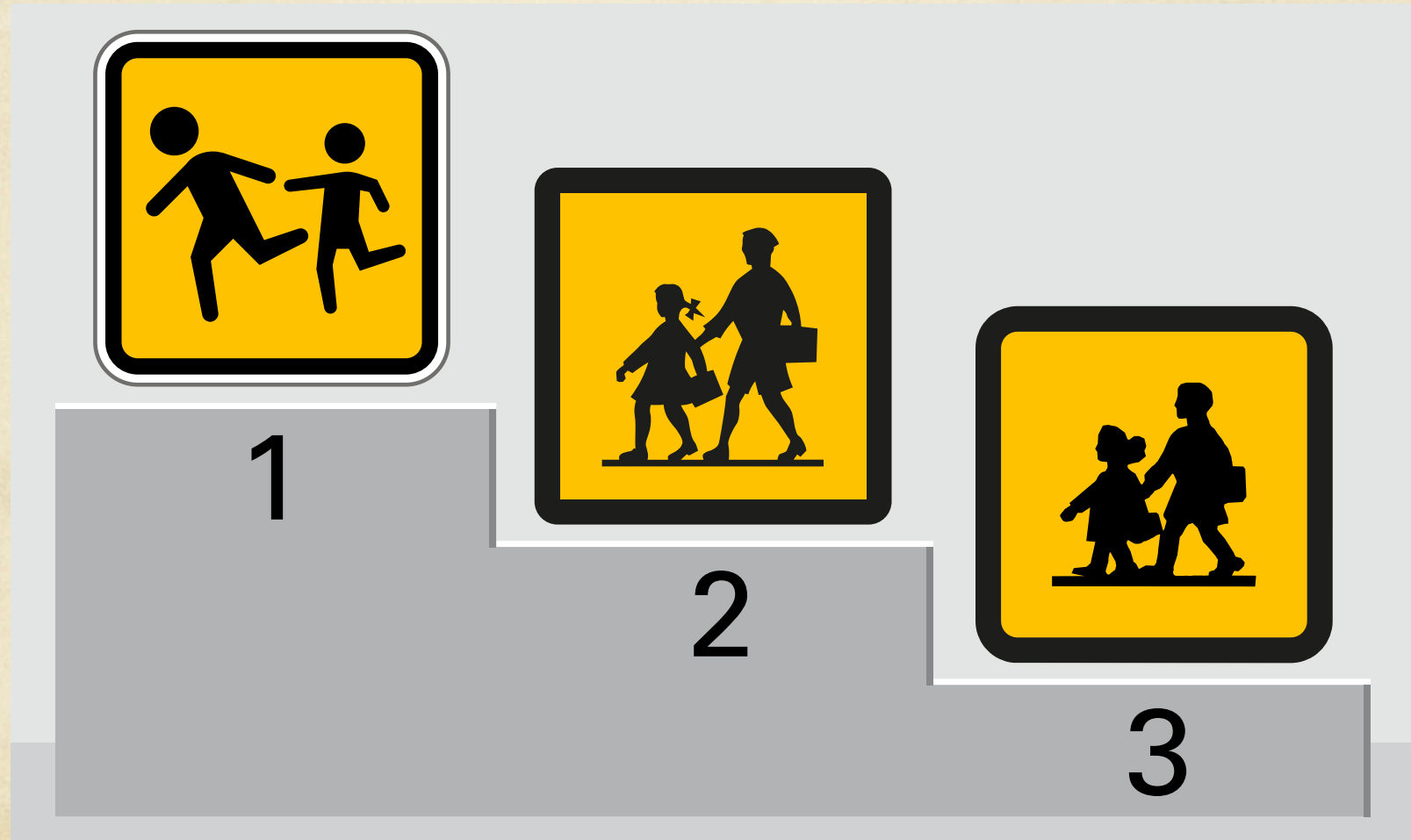

University Stuttgart/Fraunhofer Institute (2011)

MOA Design Method / 8

Prepares simultaneously for
conventional signage (vectors)

&

Enhanced dot-matrix application (screen, VMS)

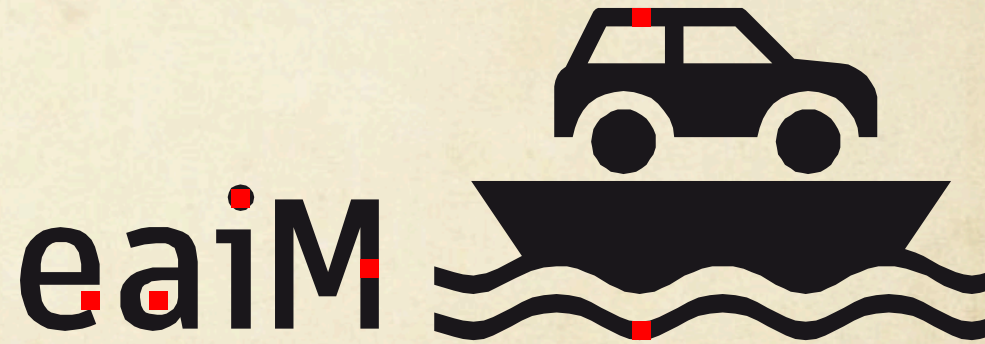
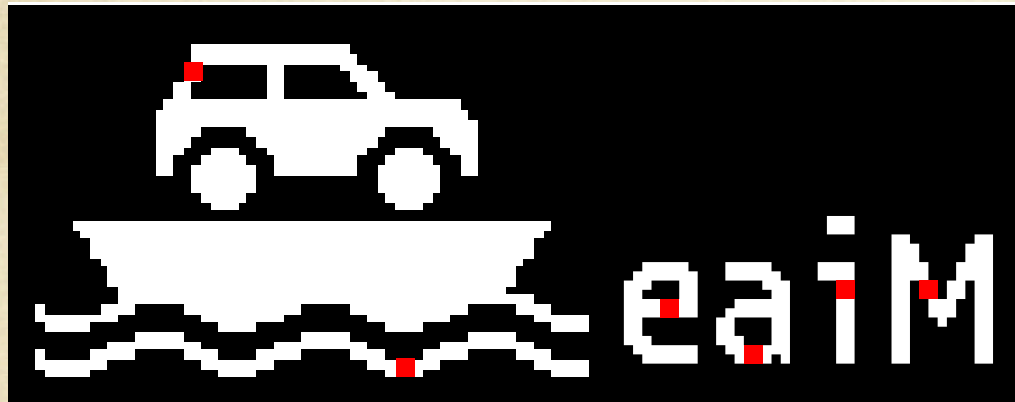

Current implementation status





















- Tern Typeface in Austria, Slovakia and The Netherlands
- Tern Symbols to be implemented in Austrian guidelines
- MOA Design Method became success criterion for new Austrian symbols

MOA Design Method / 10

















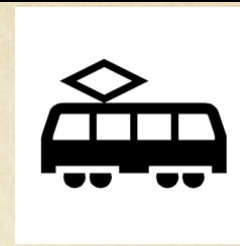

- Tern typeface legally binding use in Austria (2013) and Slovakia (2014)
- Tern VMS typeface: Standard for Full-Matrix-Displays “DRIPS” in the Netherlands (2009)

MOA Design Method / 11

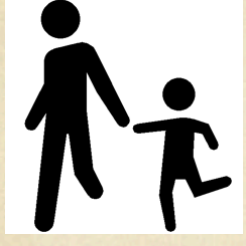
						
TS0010	TS0020	TS0030	TS0040	TS0050	TS0060	TS0070
						
TS0080	TS0090	TS0100	TS0110	TS0120	TS0130	TS0140
						
TS0150	TS0160	TS0170	TS0180	TS0190	TS0200	TS0210

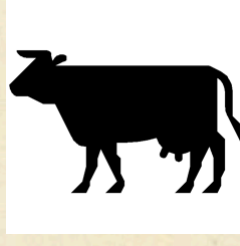

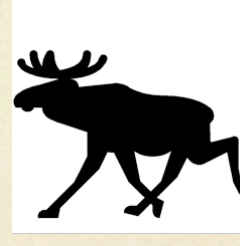







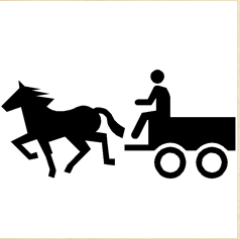



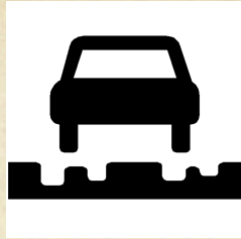
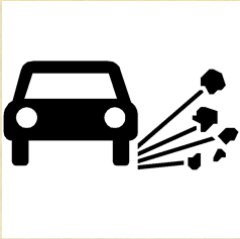

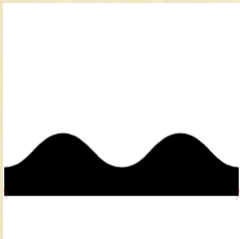
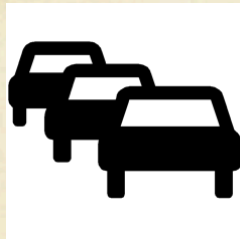
Tern Symbols: Discriminability enhanced

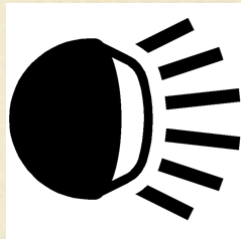
MOA Design Method / 12

						
TS0220	TS0230	TS0240	TS0250	TS0260	TS0270	TS0280
					Visual accessibility	Accessibility
TS0285	TS0290	TS0300	TS0310	TS0320	TS0330	TS0340
						
TS0350	TS0360	TS0370	TS0380	TS0390	TS0400	TS0410

Tern Symbols: Discriminability enhanced

MOA Design Method / 13

		Tank				
TS0420	TS0430	TS0440	TS0450	TS0460	TS0470	TS0480
			Danger of accidents			
TS0490	TS0500	TS0510	TS0520	TS0530	TS0540	TS0550
						
TS0560	TS0570	TS0580	TS0590	TS0600	TS0605	TS0610

Tern Symbols: Discriminability enhanced

MOA Design Method / 14

						
TS0620	TS0630	TS0640	TS0650	TS0660	TS0670	TS0680
						
TS0690	TS0700	TS0710	TS0720	TS0730	TS0740	TS0750
						
TS0760	TS0770	TS0780	TS0790	TS0800		

Tern Symbols: Discriminability enhanced

**To reduce the increased cognitive load
and increase road safety:
Improvement of signs & symbols through:**

*** ISO 9186 Test procedures *
fostering understanding**

*** MOA Design Method ***

better discrimination & precise effectivity calculation

- Reducing uncertainty while transforming information into action
- Earlier recognition and driving action

Thank you!

**Stefan Egger, IIDre
s.egger@iisdre.net**

**The MOA Design Method
stkegger.wordpress.com**

**IIDre
www.iisdre.net**

2015-11-09