

**Amendment to ECE/TRANS/WP.29/GRSG/2014/27
 (Regulation No. 110, CNG/LNG vehicles)**

This document supplements/corrects ECE/TRANS/WP.29/GRSG/2014/27 submitted to the 107th session of GRSG. The modifications to the current text of UN Regulation No. 110 are marked in bold for new characters.

Proposal for amendments to Regulation No. 110 (CNG/LNG vehicles)

Submitted by the experts from the NGV Global.

The text reproduced below was prepared by the experts from NGV Global to clarify the provisions of paragraph 18 following to include the ‘CNG accumulator’ and correct Figure 1-1 to improve clarity relative to the new Class 6.

Proposal

Insert new 18.3.2.8 to read;

18.3.2.8 CNG accumulator

Modify Figure 1-1 to add a new ‘Class 6’

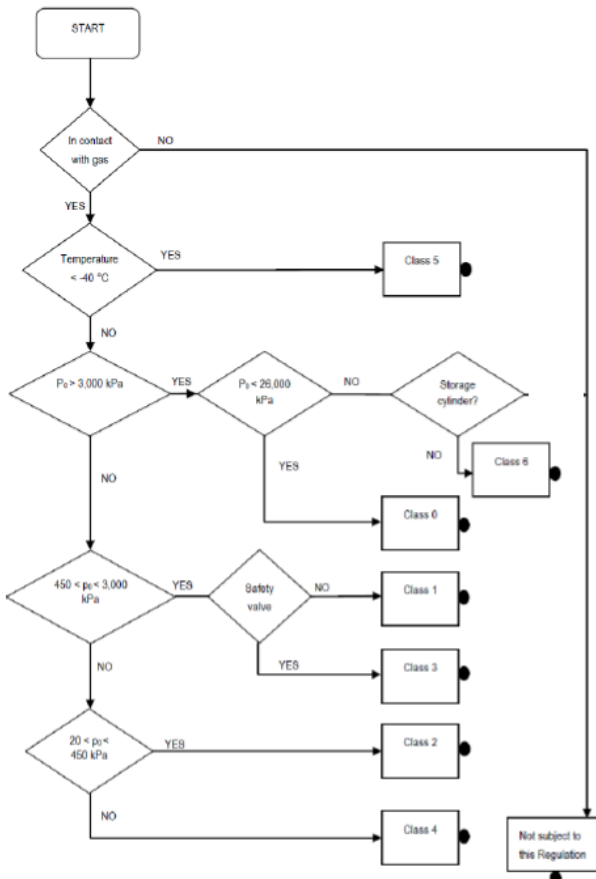

Definitions Section 4

Insert new paragraph

4.77. **“CNG accumulator” means a CNG buffering device below 10 litres in volume.**

II. Justification

1. In response to the GRSG discussion of Document ECE-TRANS-WP29-GRSG-2014-27e and a question posed by the French delegation to clarify Figure 1-1 and remove ‘Yes’ option from the ‘storage cylinder?’ decision box.
 2. The component ‘accumulator’ is not included in the list of components or definitions and is added here to fill that void.
-