

VGS-062  
Date: 2014-04-01

GTB Document No. CE-5001  
Date: 2014-04-01

# GTB Task Force

## Coordination of **Automotive Visibility** and **Glare Studies**

### Report April 2014

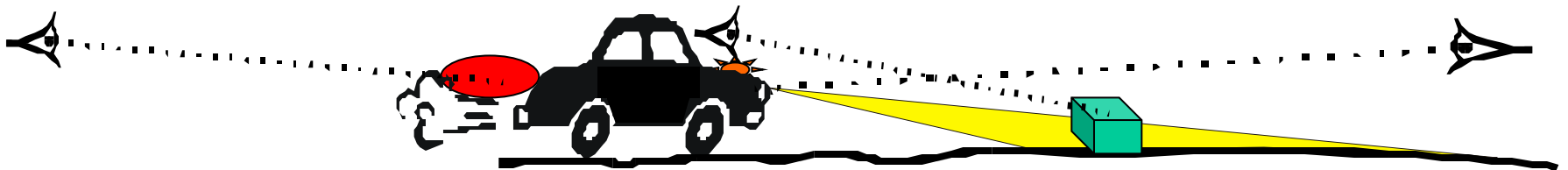

# Agenda

1. **GTB**

Introduction

2. **Poland**

Explanation of the background of the Polish proposal for R48

3. **GTB**

Literature Review

Night-time Field Test

Discussion

Comparison Klettwitz Outcome with Literature

Enrichment of Data by Calculation (CIE TC4-45)

4. **OICA**

Explanation of load conditions

5. **Joint GTB/Poland/OICA**

Conclusion

Suggestion

# Agenda

## 1. GTB

Introduction

## 2. Poland

Explanation of the background of the Polish proposal for R48

## 3. GTB

Literature Review

Night-time Field Test

Discussion

Comparison Klettwitz Outcome with Literature

Enrichment of Data by Calculation (CIE TC4-45)

## 4. OICA

Explanation of load conditions

## 5. Joint GTB/Poland/OICA

Conclusion

Suggestion

# Introduction

Ad de Visser  
chair TF CAVGS

# Introduction<sup>1/</sup>

Arrangement of presentations in the program is a mix of

- activities in chronological order
- building blocks to constructing the puzzle
- in logical order for a better understanding

# Start

- Proposal<sup>1/</sup> to introduce gas discharge light sources with an objective luminous flux of 2000 lm
- Proposal<sup>2/</sup> to require automatic levelling for all low beam headlamps independent from
  - the light source technology
  - the light source luminous flux

<sup>1/</sup> WP.29/2011/101

<sup>2/</sup> WP.29/2011/99 and Corr.1

# Automatic leveling proposal

- Long transitional period of 90 months
- GRE indicated
  - to be open for relaxation of this new requirement
  - for adopting alternatives based upon study
  - in the beginning of this transitional period
- Proposal<sup>2/</sup> stalled in the GRE agenda and discussion was deferred for ~2 or 3 years
  - until today
- The expert from Poland worked on new initial aiming requirements
  - Different approach
  - OICA commented on this proposal

This is why Poland and OICA contribute with presentations to provide background information

<sup>2/</sup> WP.29/2011/99 and Corr.1

# GTB study<sup>1/</sup> '*Visibility and Glare*'

- Task force TF CAVGS
  - Coordination of Automotive Visibility and Glare Studies
- Publically accessible home page
  - <http://www.gtb-lighting.org/VGS/indexVGS.htm>
- Concentrated on levelling in relation to load
- Major objectives
  - to improve the understanding of different factors that influence visibility and glare; **start of the presentations**
  - to identify results of the study that might reveal alternatives for automatic static levelling; **end of the presentations**

<sup>1/</sup> GRE-66-21  
GRE-67-39



# GTB Task Force CAVGS

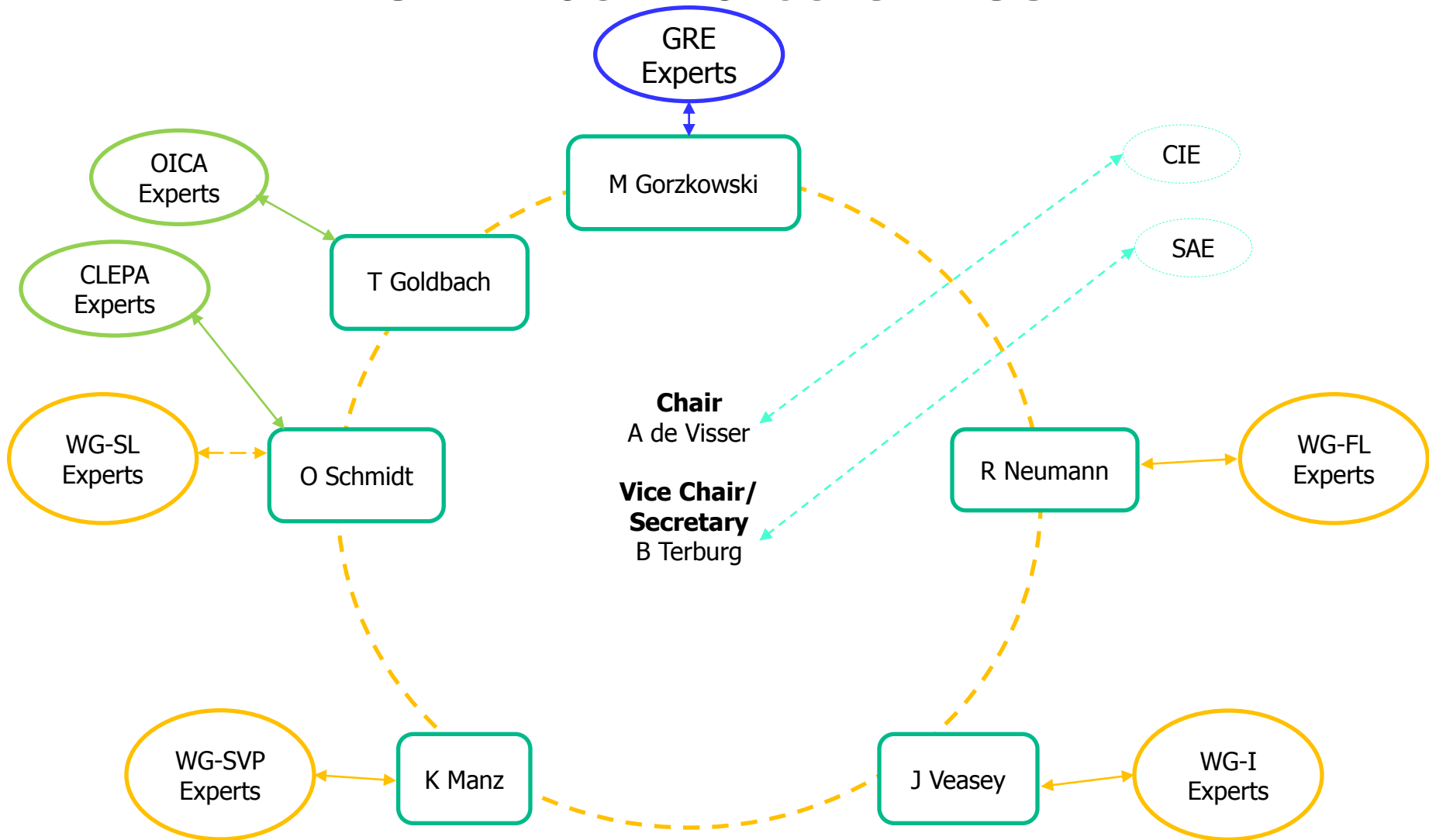

see GRE-66-21

# Presentations

## Part: “Understanding”

- Extending earlier presentations
  - Literature review by WG SVP<sup>2/</sup>
  - Field test by WG FL<sup>1/</sup>
    - Cooperation with DEKRA and TUD
- Discussion in response to comments/ questions
  - From GRE68
  - From GTB in several sessions
  - By simulations based upon assumptions
    - See next slide
  - Field test and simulations were “validated” with literature
  - Simulations were compared with those from the expert from Poland
- Conclusion of the study

<sup>1/</sup> GRE-68-38

<sup>2/</sup> GRE-68-39

# Assumptions

- Every testing and simulation is based upon certain assumptions and choice of parameters
  - Each set of assumptions has its weaknesses
  - GTB used an international accepted standard  
*CIE S 021/E:2011: Vehicle Headlighting Systems Photometric Performance - Method of Assessment*
  - The expert from Poland
    - will explain their set of assumptions
    - agreement with GTB to disagree on some aspects

# Presentations

## Part “Identifying alternatives”

- Alternatives for automatic static levelling
  - Based upon the outcome of the studies
- Headlamp aiming is always a compromise
  - There is no perfect solution possible
  - Glare complaints are inherent to visibility of the road ahead for the driver

# After presentations

## Consideration by GRE

## Guidance for next steps

# Agenda

1. **GTB**

Introduction

2. **Poland**

Explanation of the background of the Polish proposal for R48

3. **GTB**

Literature Review

Night-time Field Test

Discussion

Comparison Klettwitz Outcome with Literature

Enrichment of Data by Calculation (CIE TC4-45)

4. **OICA**

Explanation of load conditions

5. **Joint GTB/Poland/OICA**

Conclusion

Suggestion

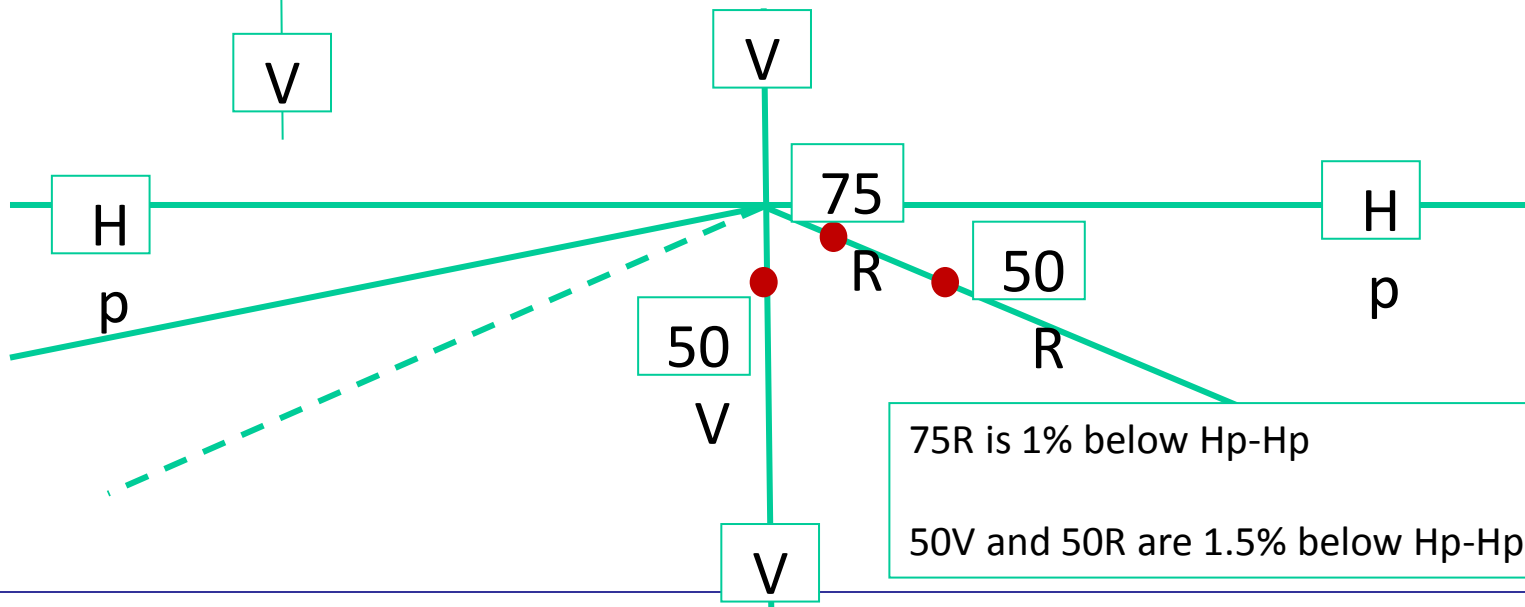
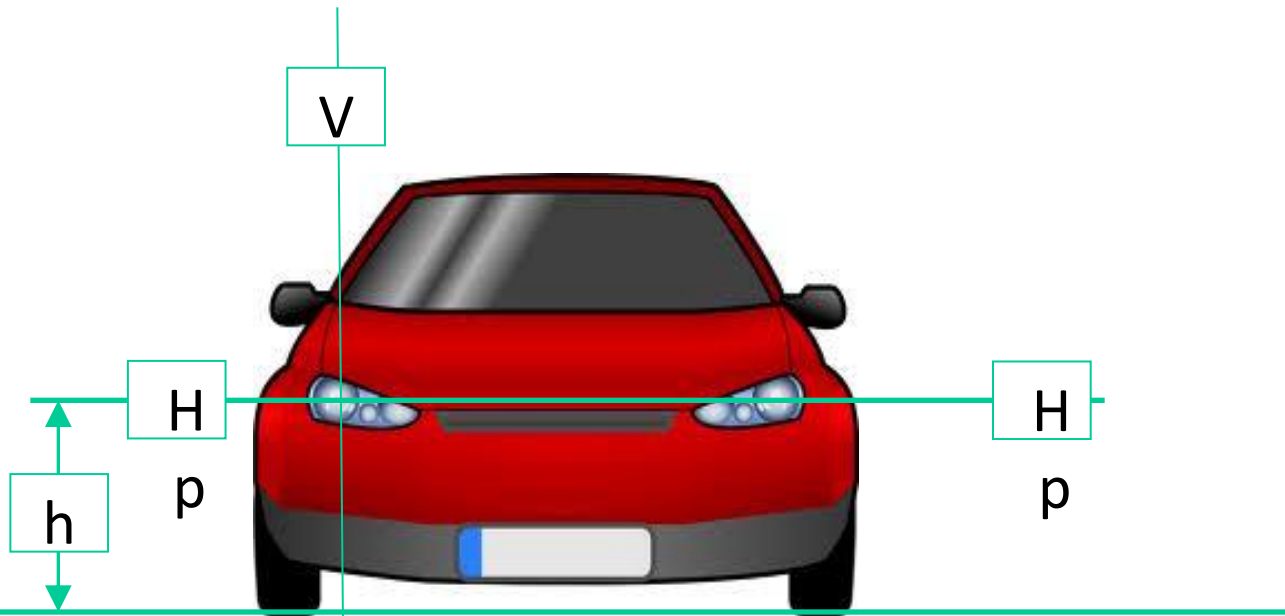

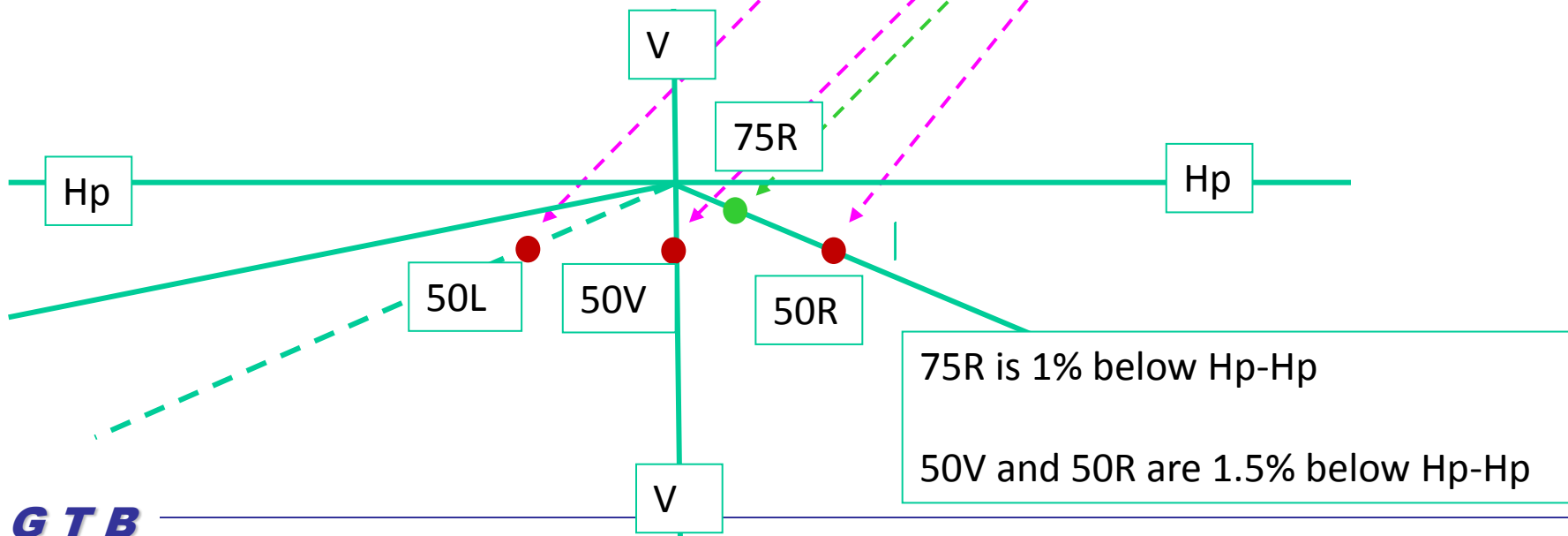
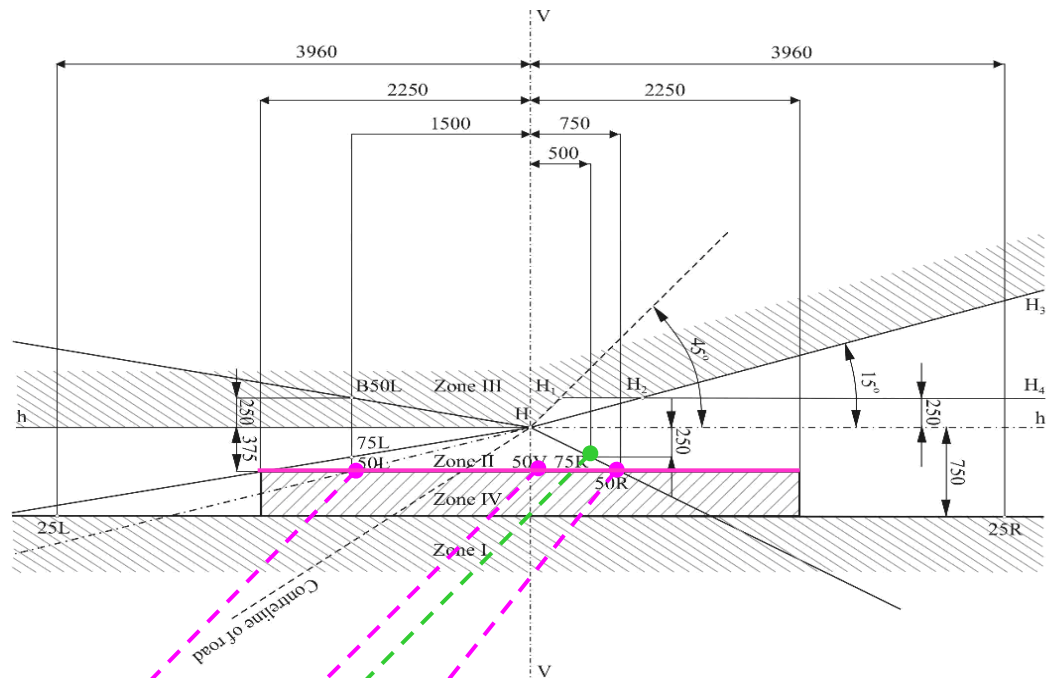



# TRANSLATION OF SCREEN PHOTOMETRY TO ROAD H=0.75m, I=1%D

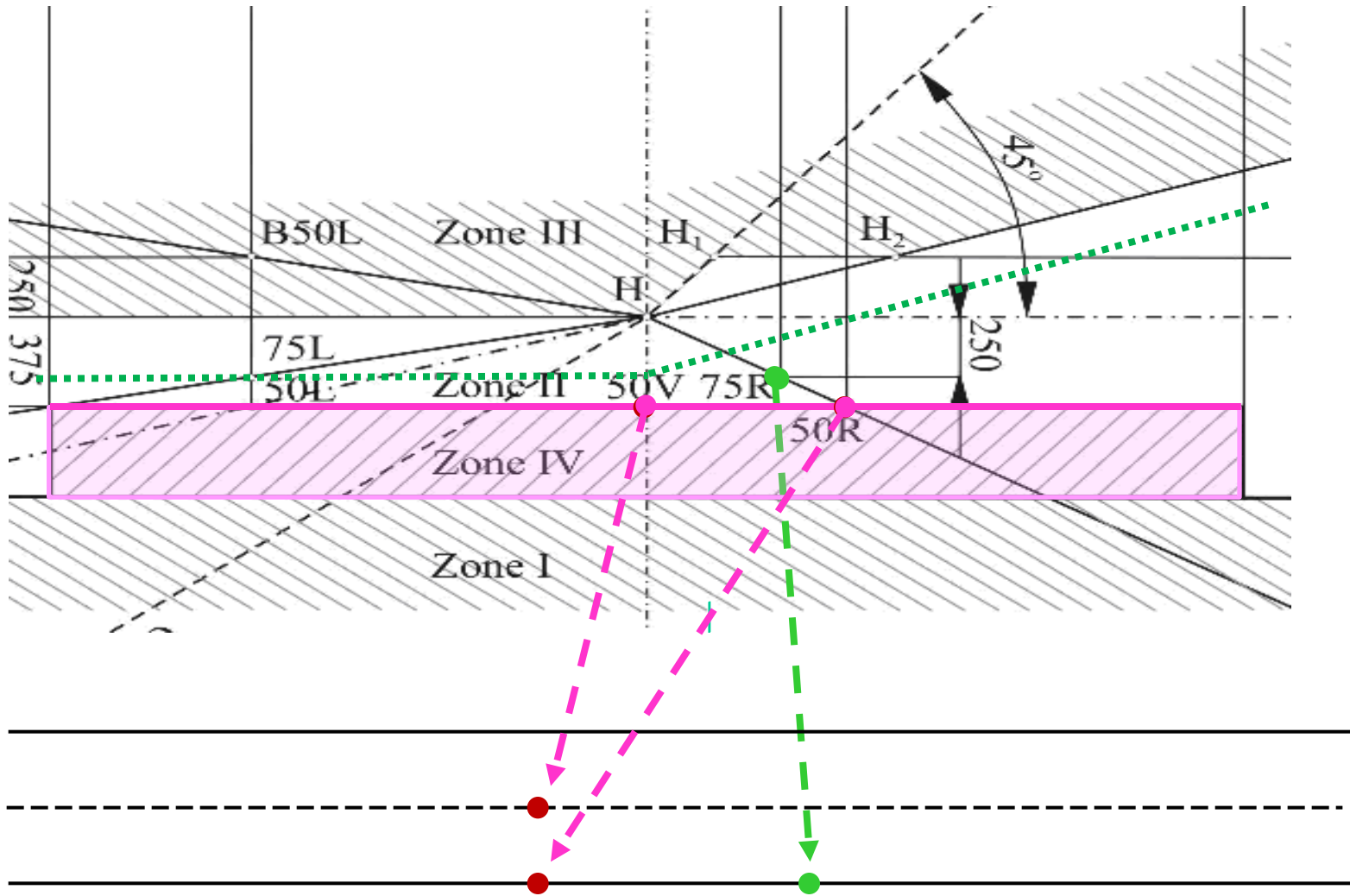

Illuminances from 25 m screen translated to the road by headlamp mounting height (h) of 75 cm

**For 75R** the minimum value is 16.8 lux @25m

Illuminance at 75 m =  $16.8 / (75/25)^2 = \mathbf{1.87 \text{ Lux}}$  at the road surface.

**For 50R** the minimum value is 16.8 lux @25m

Illuminance at 50m =  $16.8 / (50/25)^2 = \mathbf{4.2 \text{ Lux}}$  at the road surface.

**For 50V** the minimum value is 8.4 lux @25m

Illuminance at 50m =  $8.4 / (50/25)^2 = \mathbf{2.1 \text{ Lux}}$  at the road surface.

# TRANSLATION OF SCREEN PHOTOMETRY TO ROAD H=0.75m, l=1%D

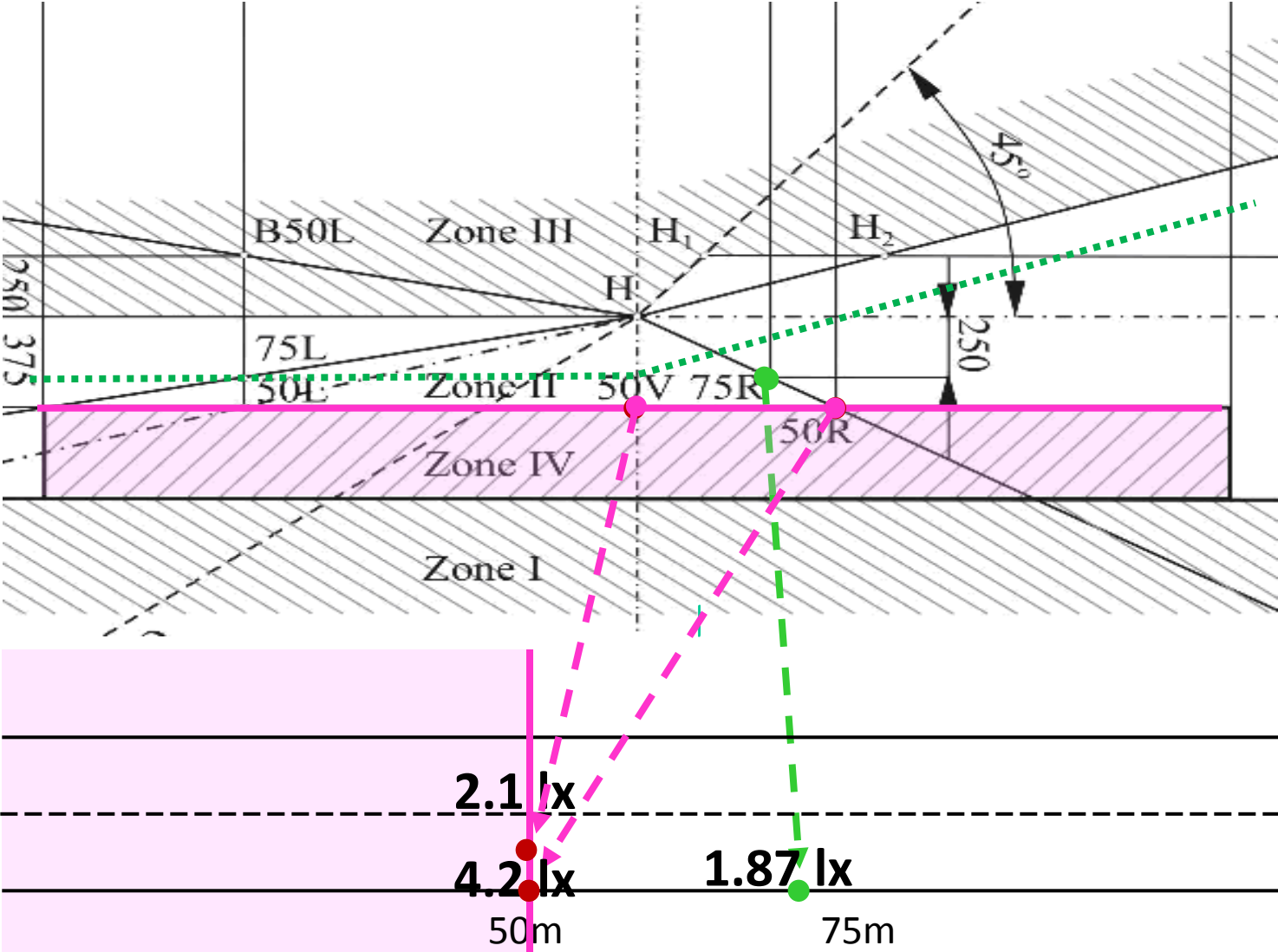

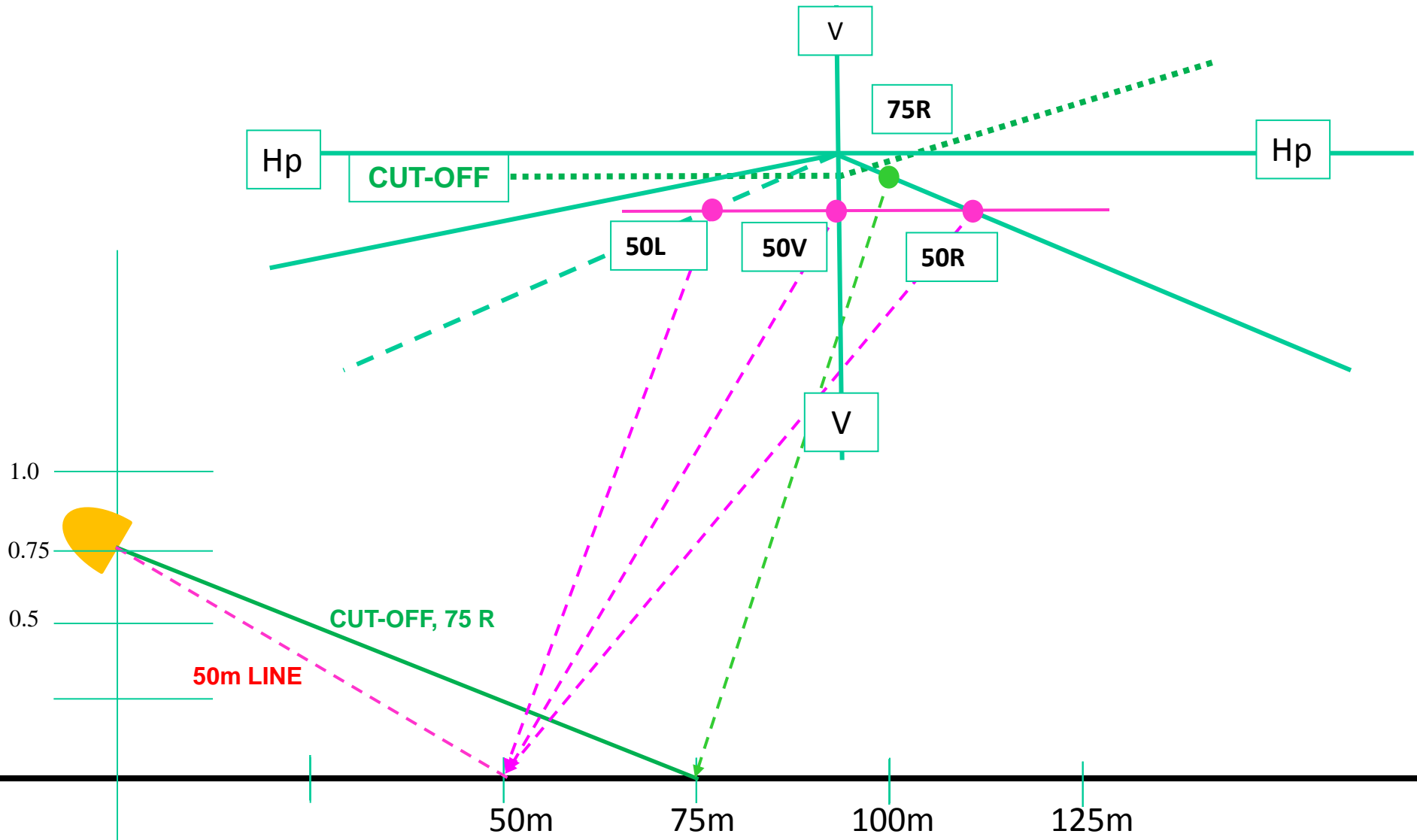

# HOW DEPEND ROAD ILLUMINATION OF AIMING AND BEAM PATTERNS CALCULATION EXAMPLES

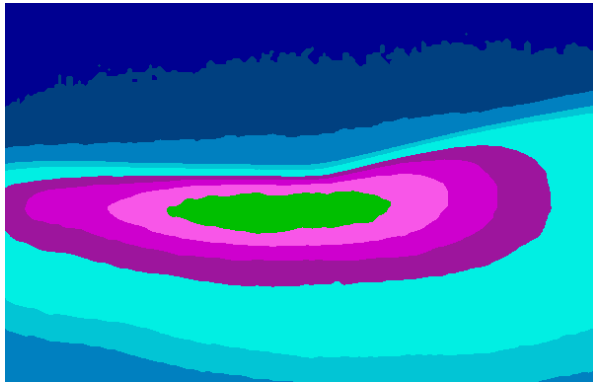
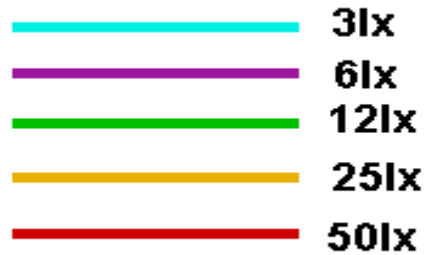

**HEADLAMP A**

Minimum performing headlamp  
just over type approval minimums

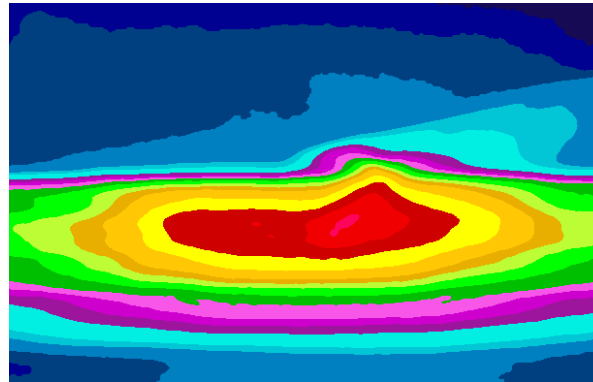

**HEADLAMP B**

LED headlamp with horizontally  
nearly symmetrical beam pattern

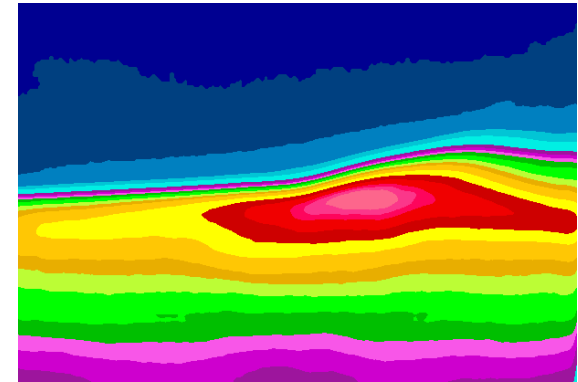

**HEADLAMP C**

High efficiency HID headlamp  
much more than required minimum

**FIXED AIMING (1.0% D)  
AND DIFFERENT MOUNTING HEIGHTS  
= 0.50m, 0.75 m and 1.00m**

**Different headlamps illuminates road  
differently by the same aiming and  
mounting height**

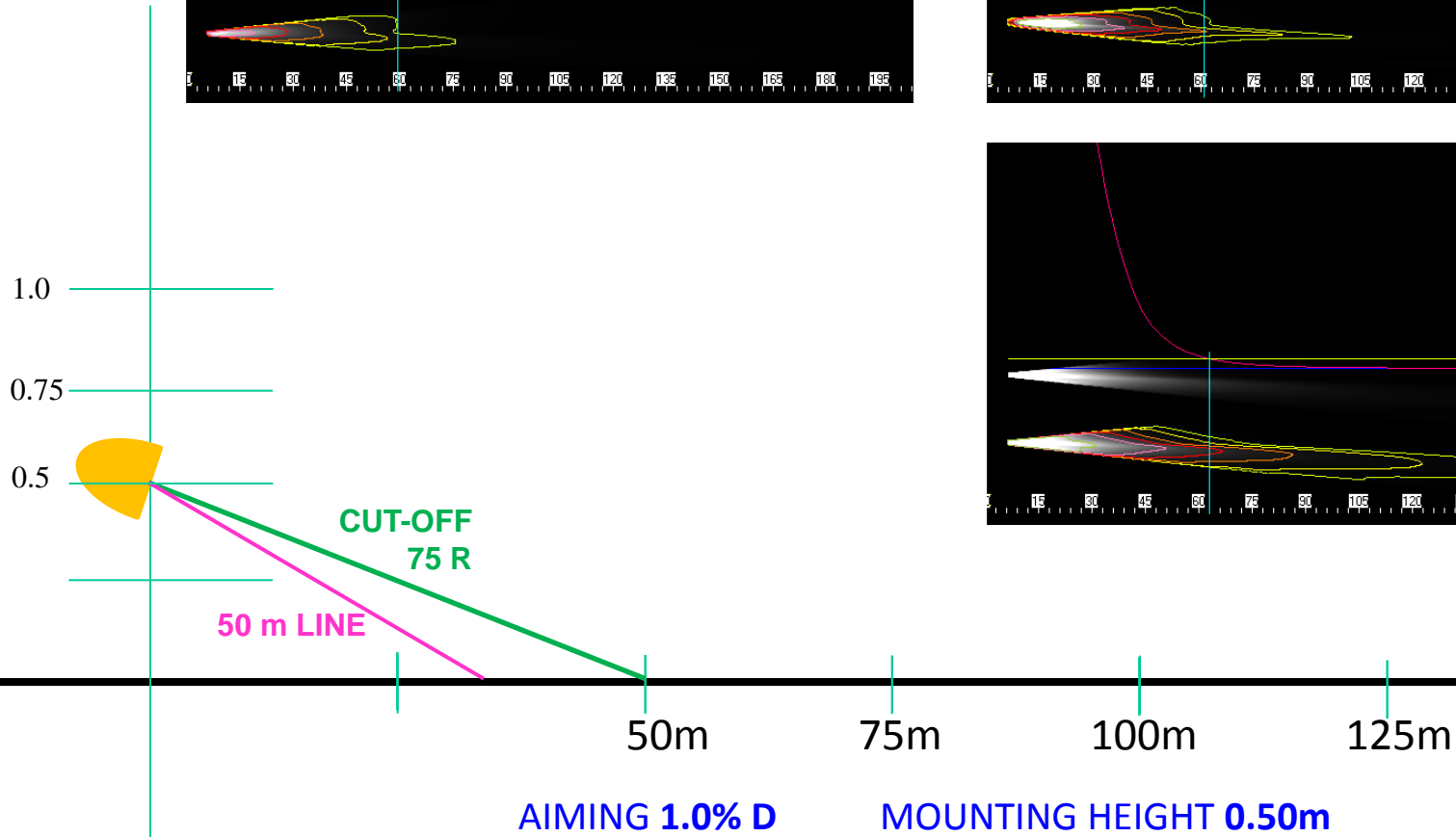
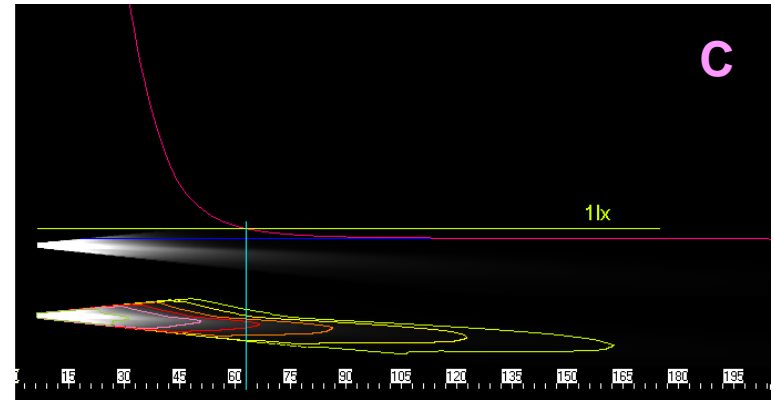
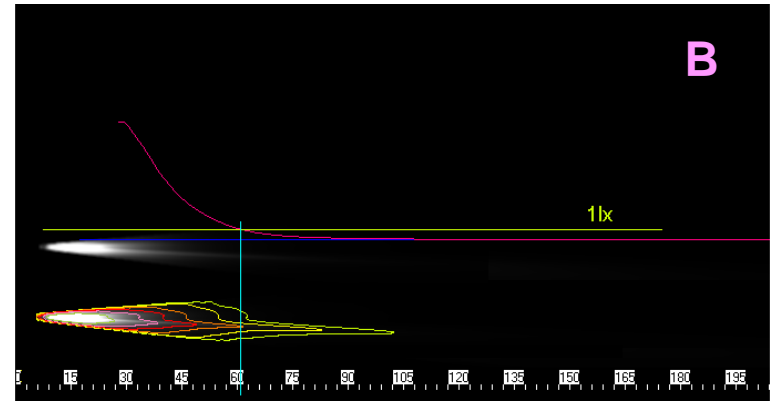
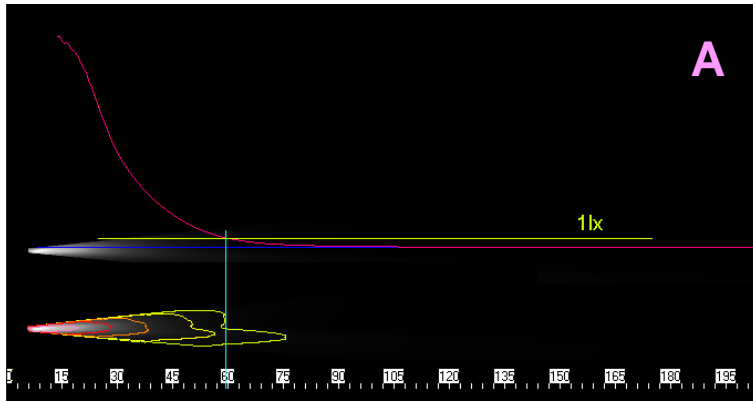

# ROAD ILLUMINATION, AIMING 1% D, HEIGHT 0.5m

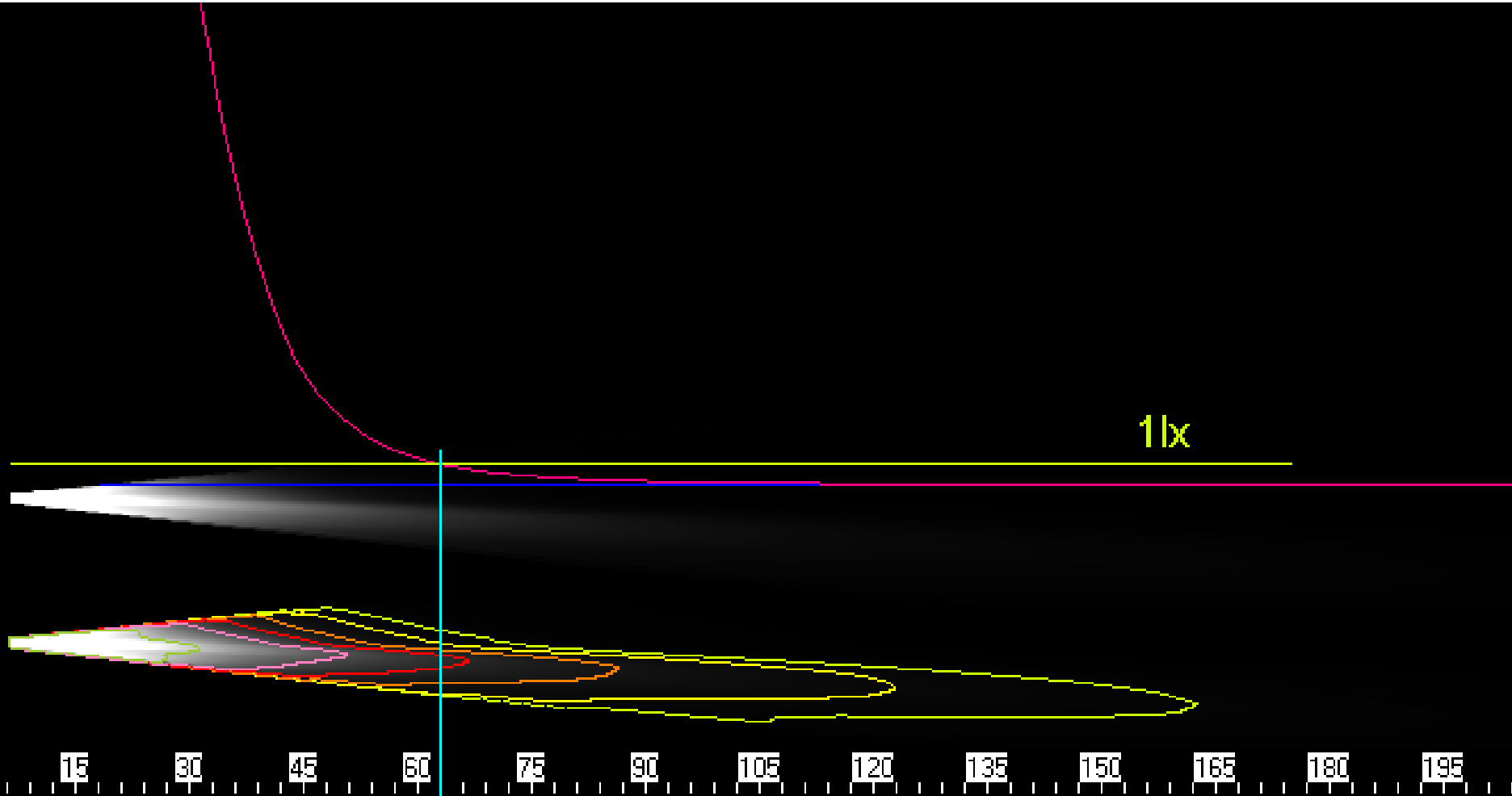



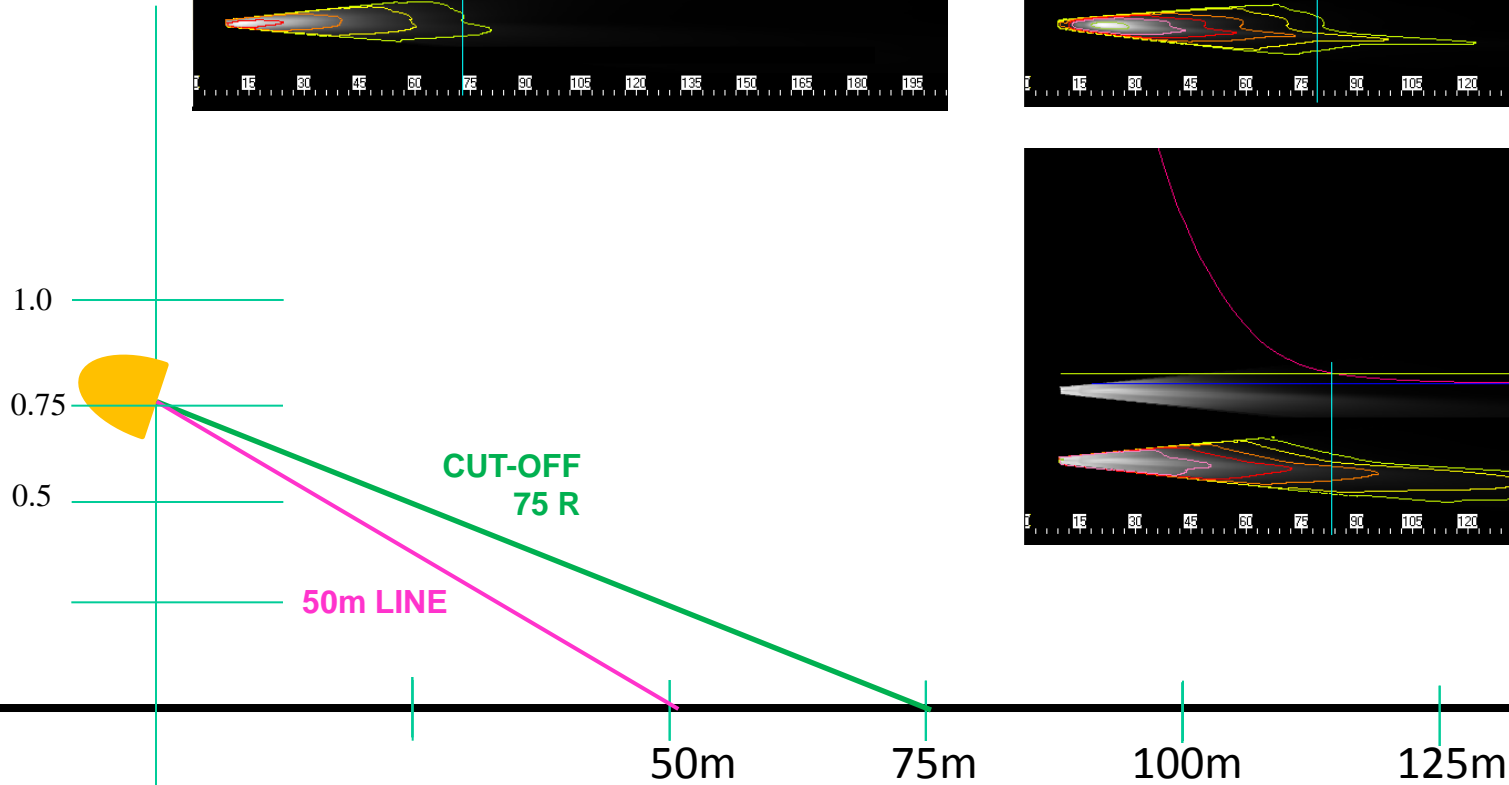
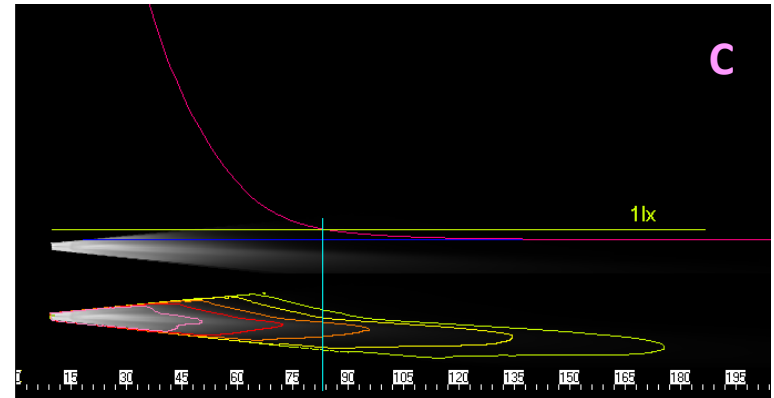
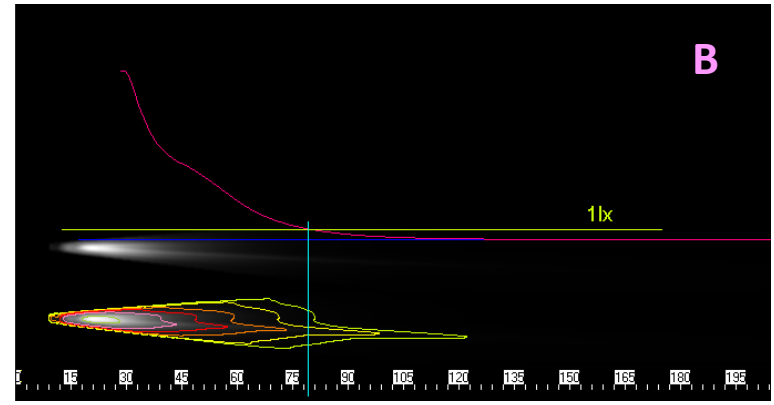
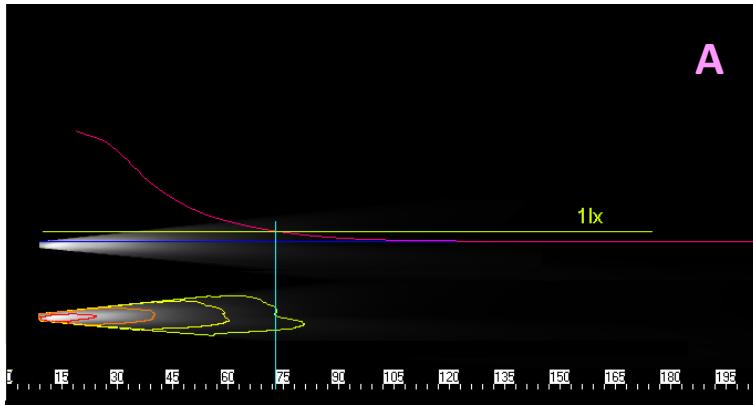

CUT-OFF  
75 R

50m LINE

AIMING 1.0% D

MOUNTING HEIGHT 0.75m

# ROAD ILLUMINATION, AIMING 1% D, HEIGHT 0.75m

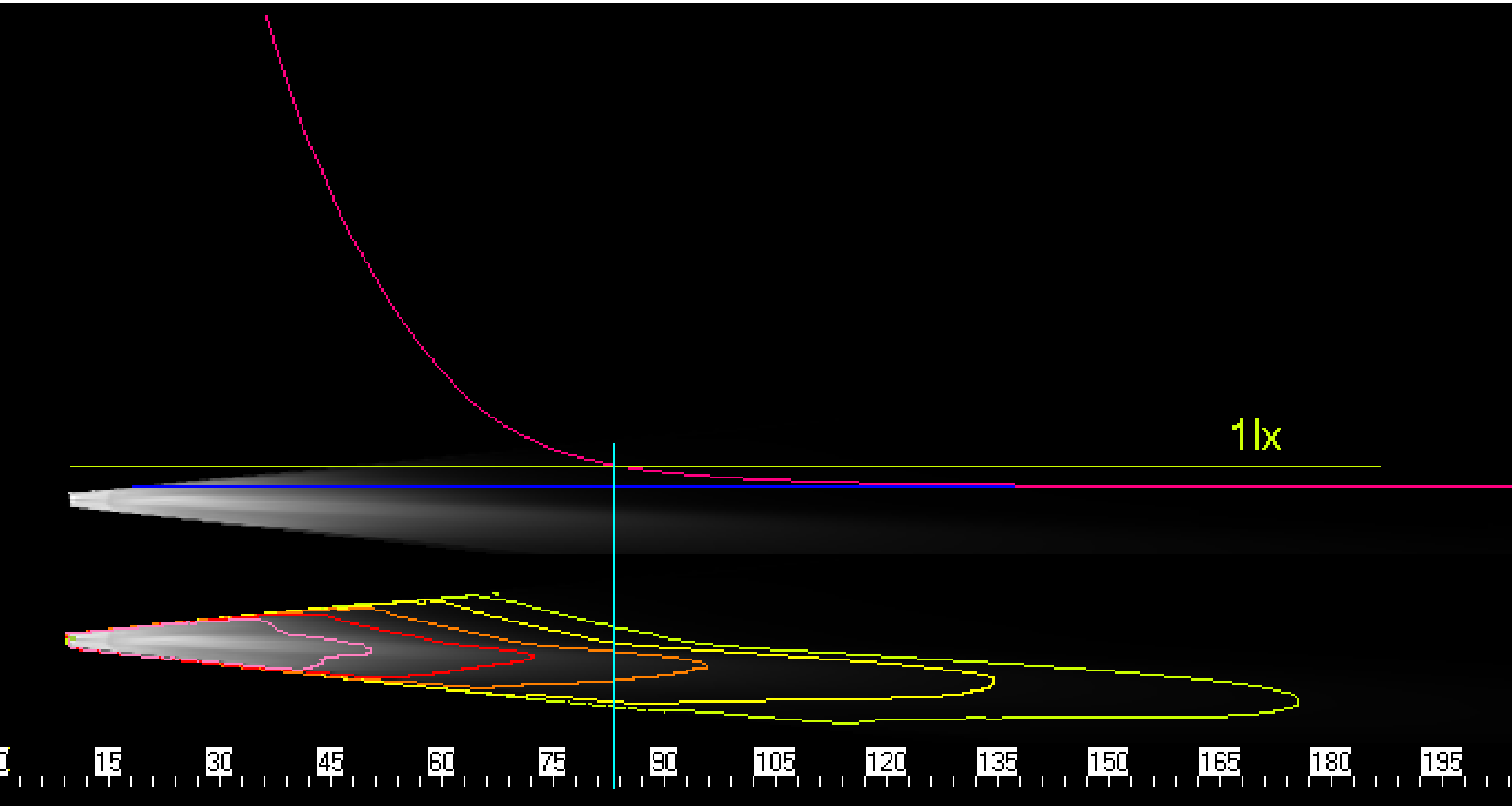

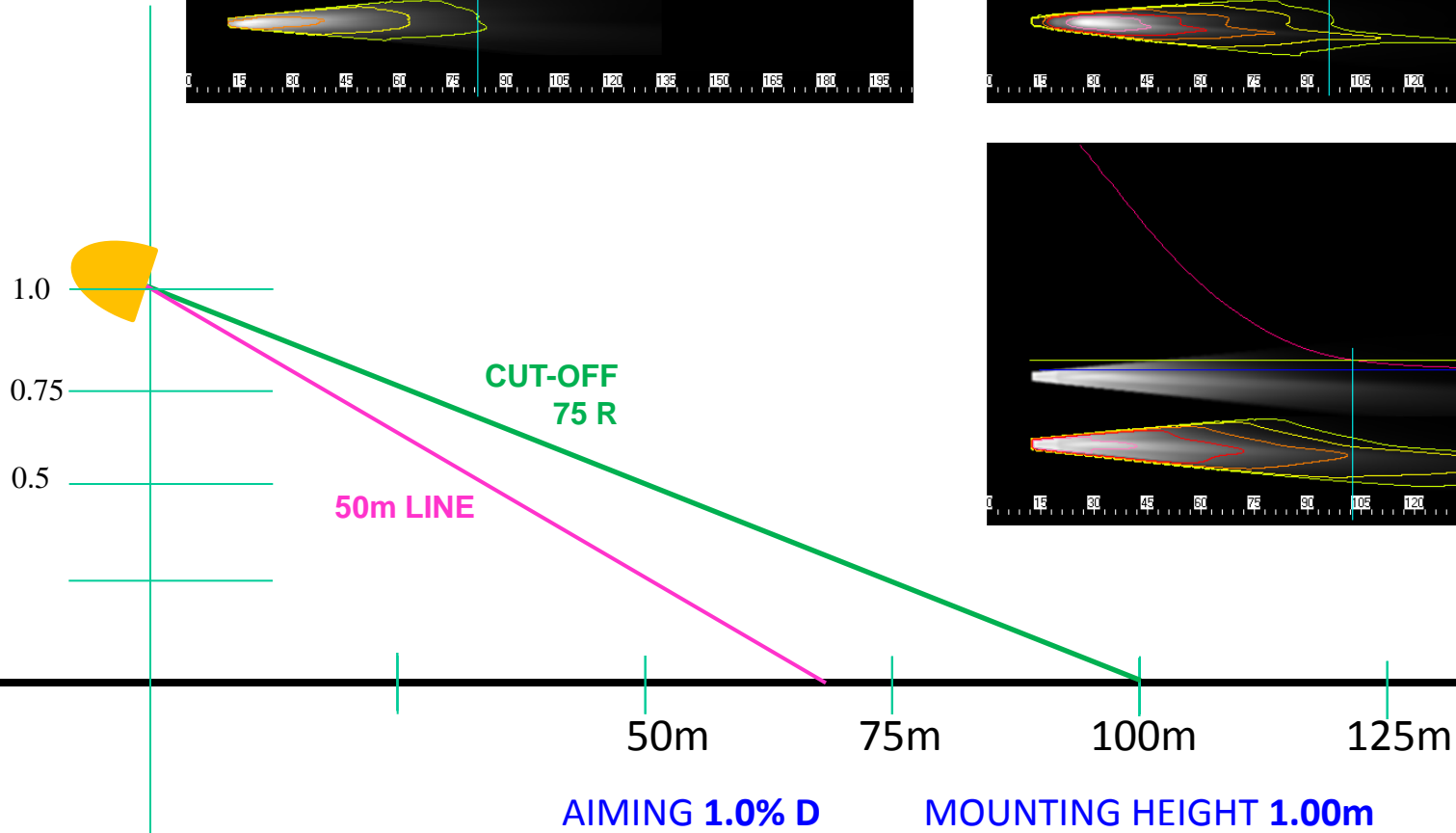
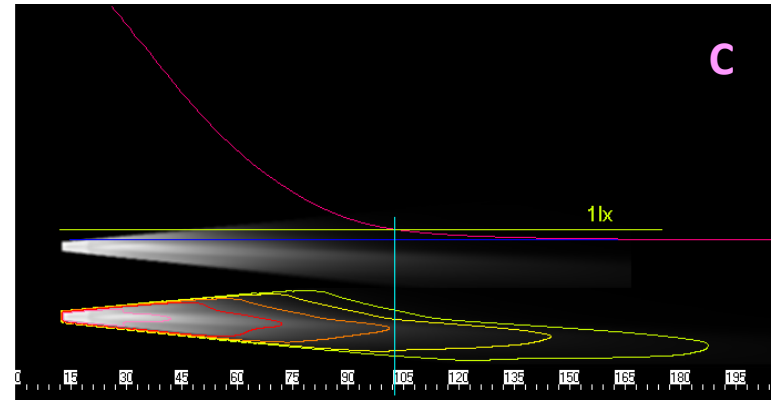
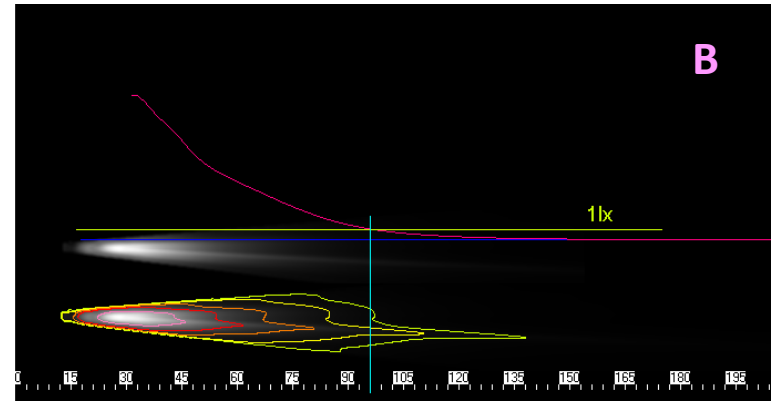
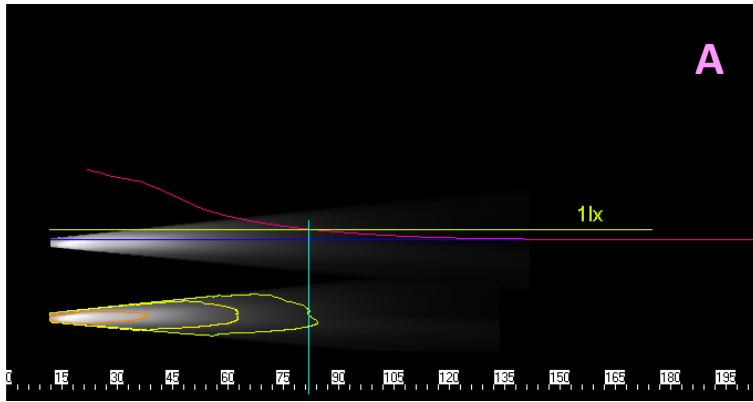

# ROAD ILLUMINATION, AIMING 1% D, HEIGHT 1.0m

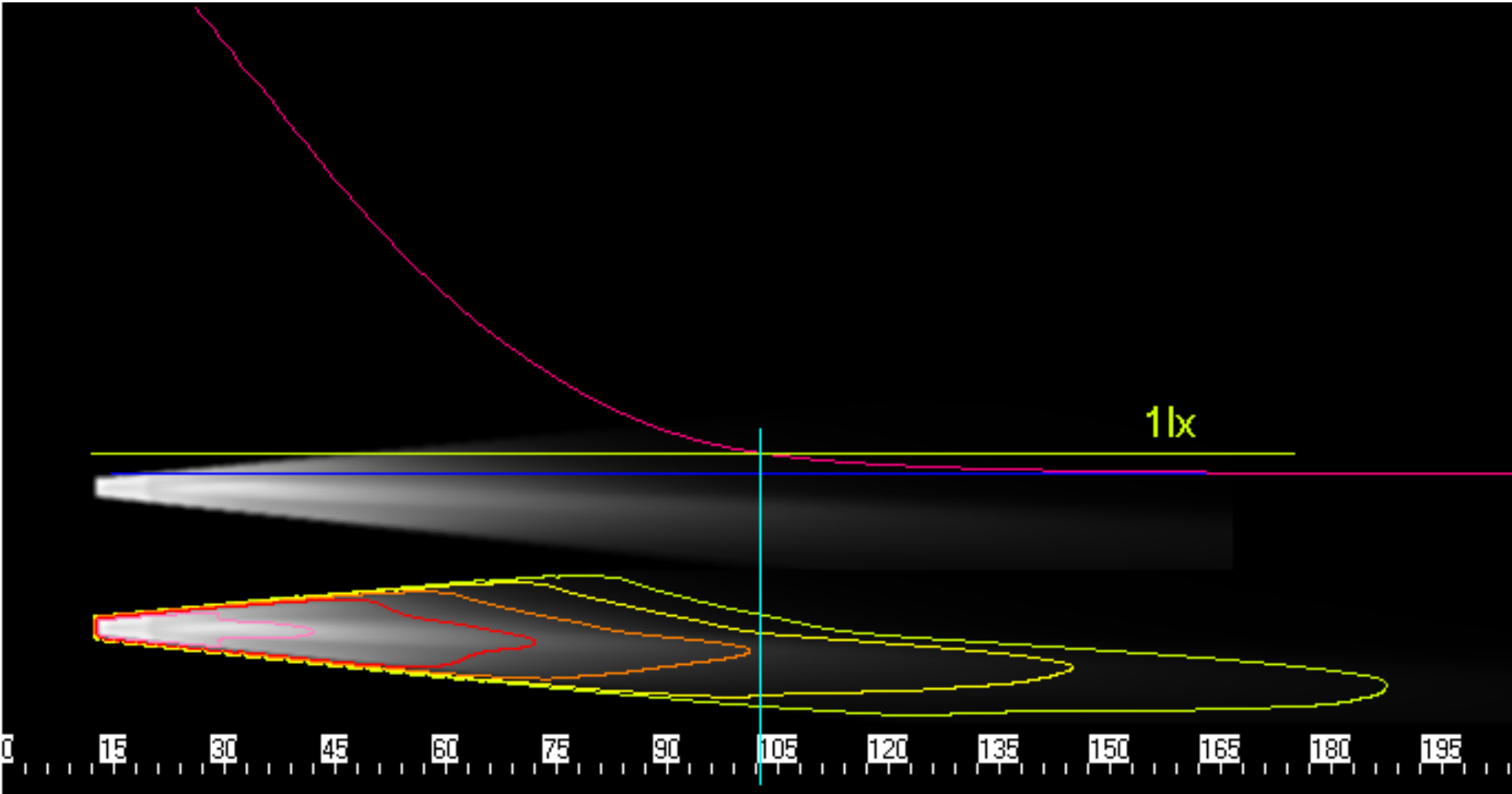

# HEADLAMP A , AIMING 1%D, HEIGHT CHANGE 0.5 m, 0.75m 1.0m

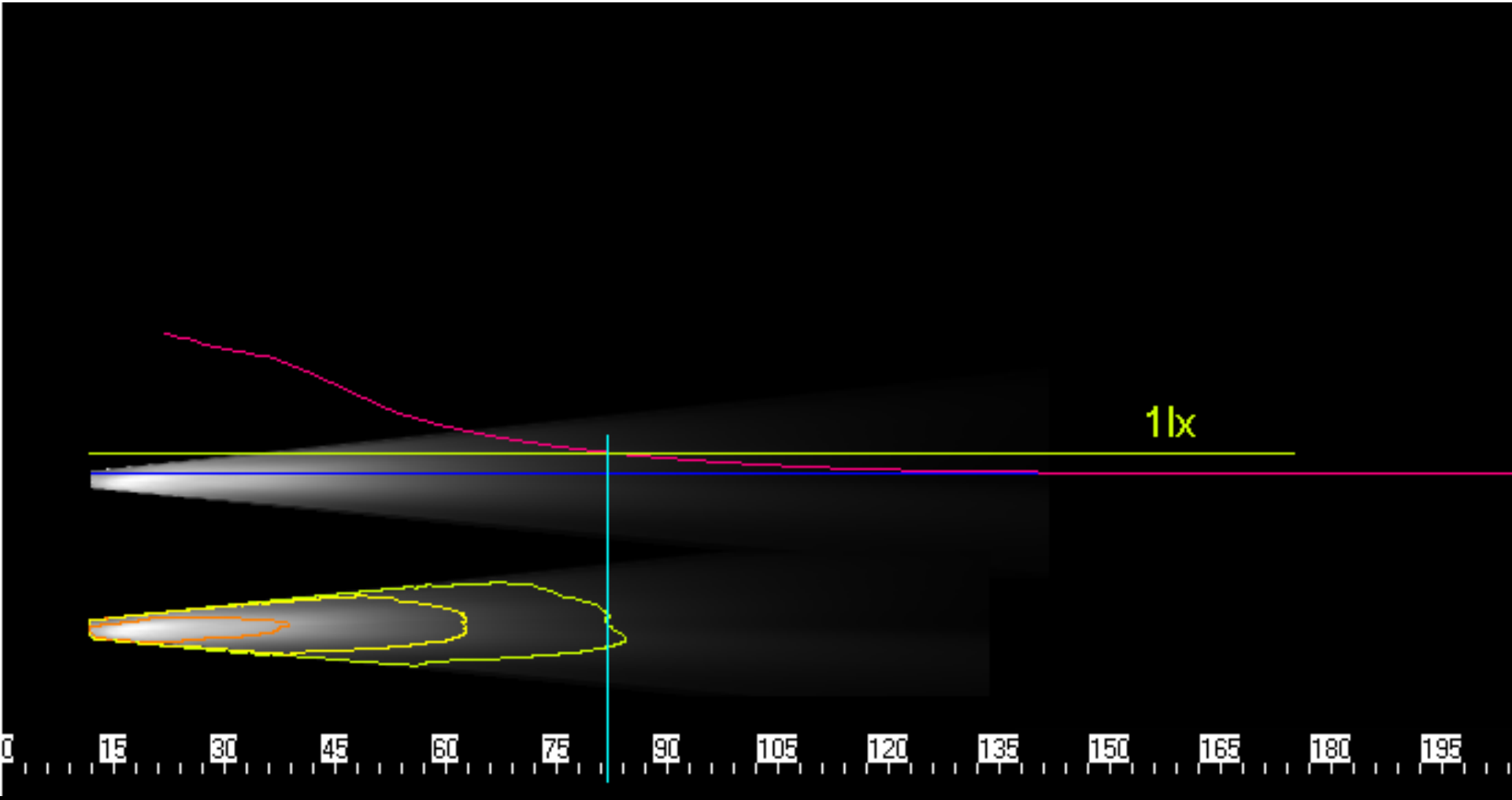

# HEADLAMP C , AIMING 1%D, HEIGHT CHANGE: 0.5 m, 0.75m 1.0m

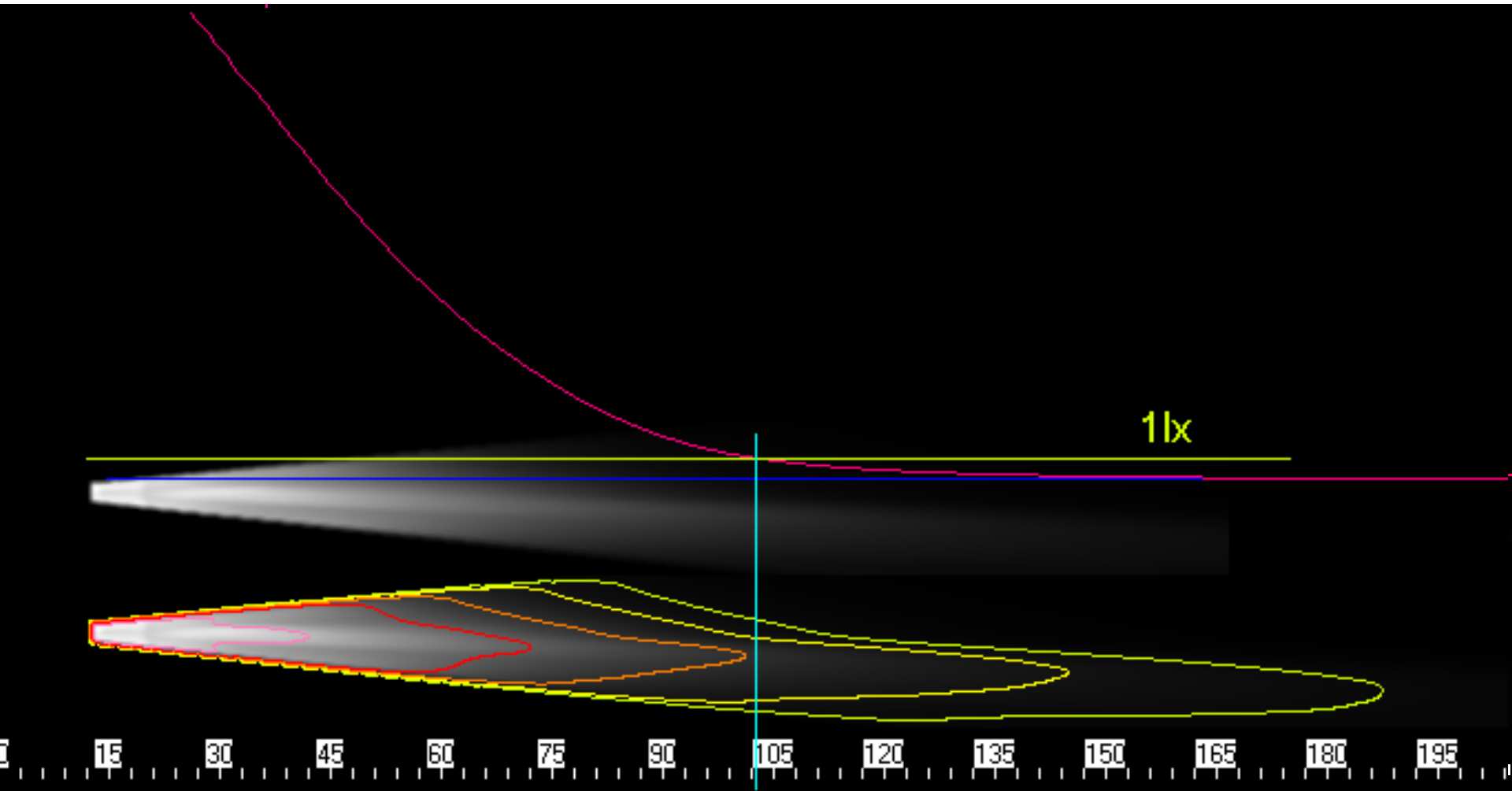

# COMPARISONS OF RANGE FOR DIFFERENT AIMING AND BEAM PATTERN

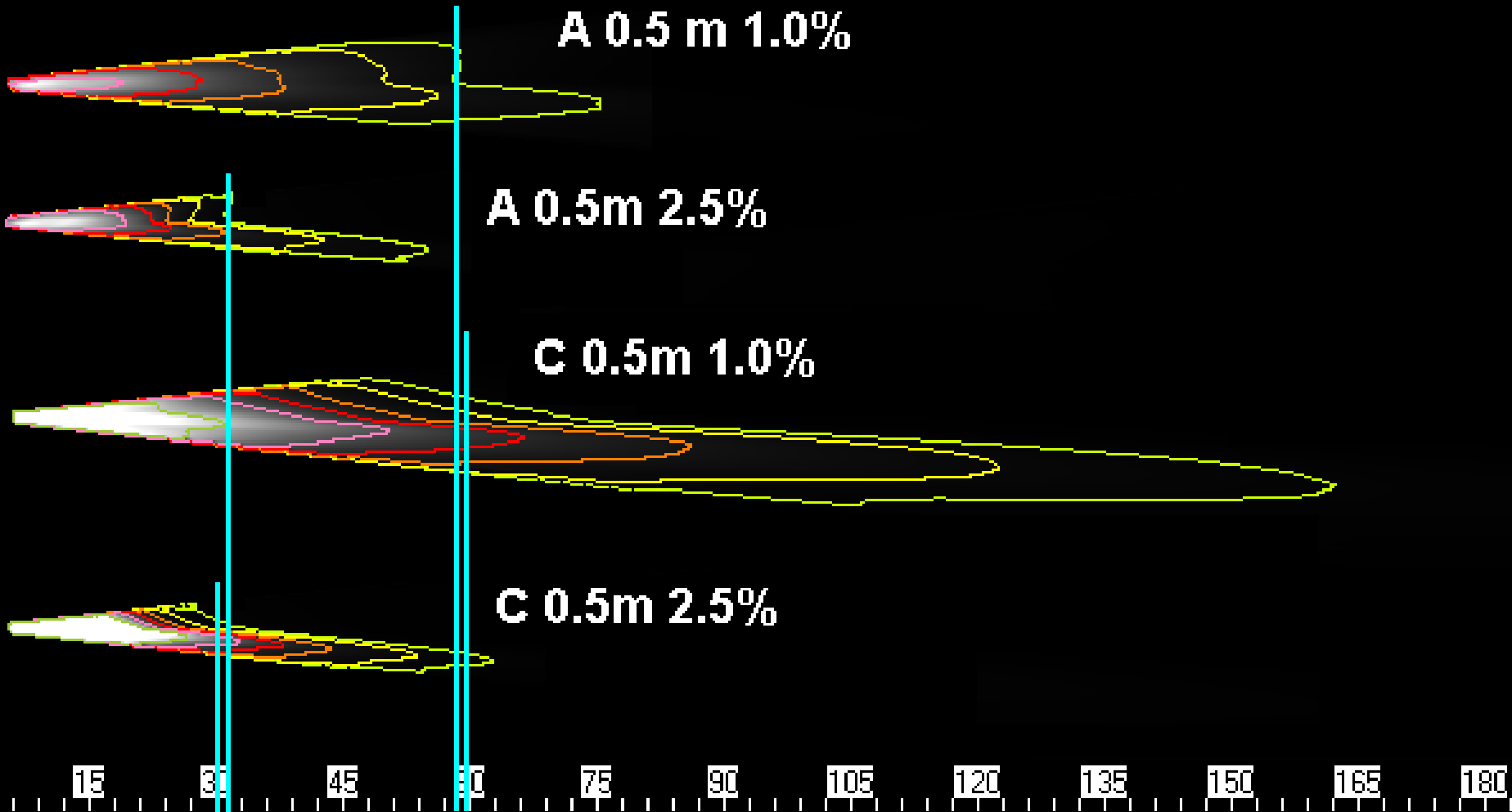

# Reg. 48 aiming / levelling provisions



OR





# ESSENCE OF POLISH PROPOSAL

**NO MEASURABLE CHANGE  
OF ROAD ILLUMINATION  
IN REFERENCE POINTS  
WITH MOUNTING HEIGHT**

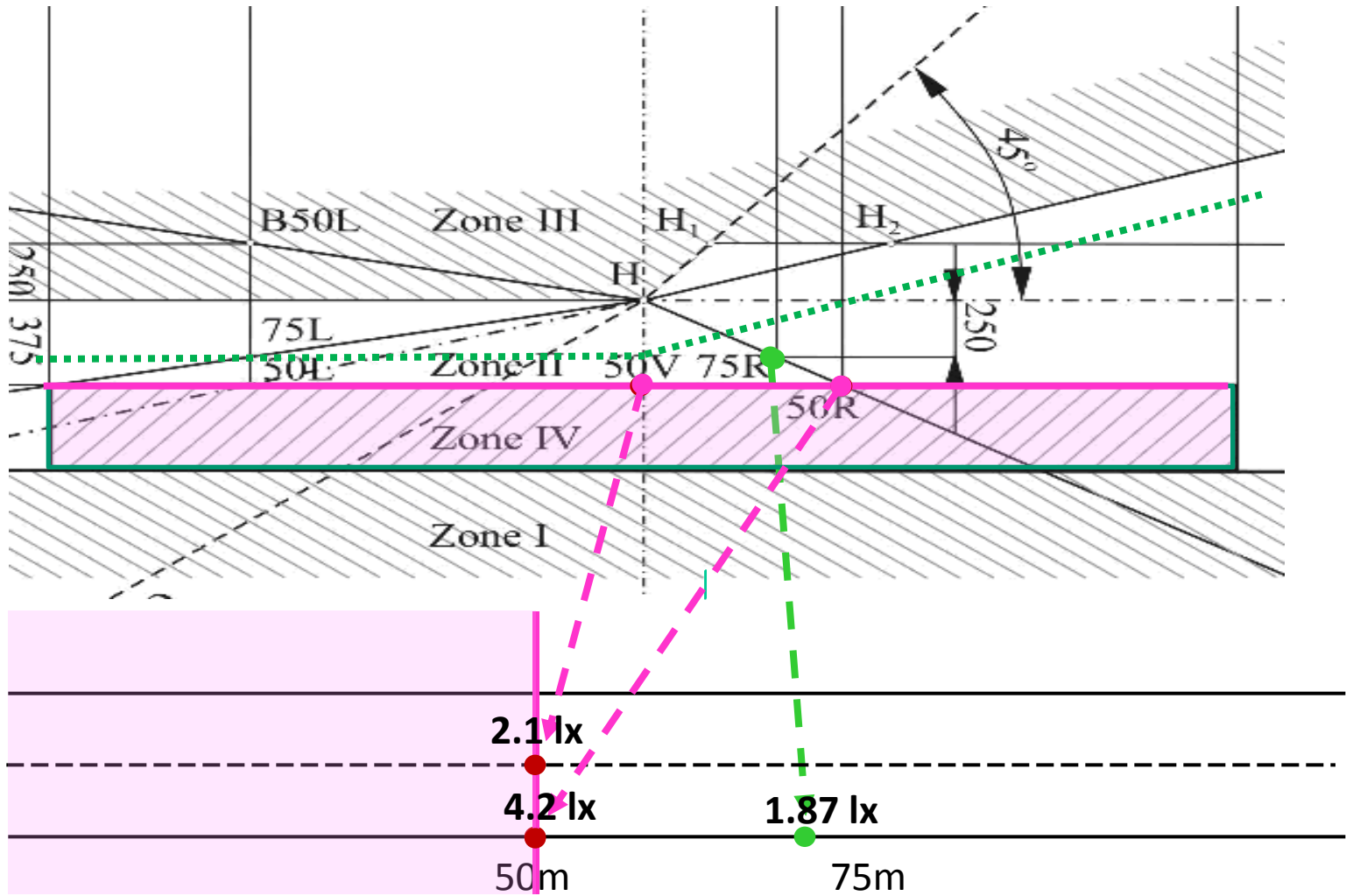

# ESSENCE OF POLISH PROPOSAL

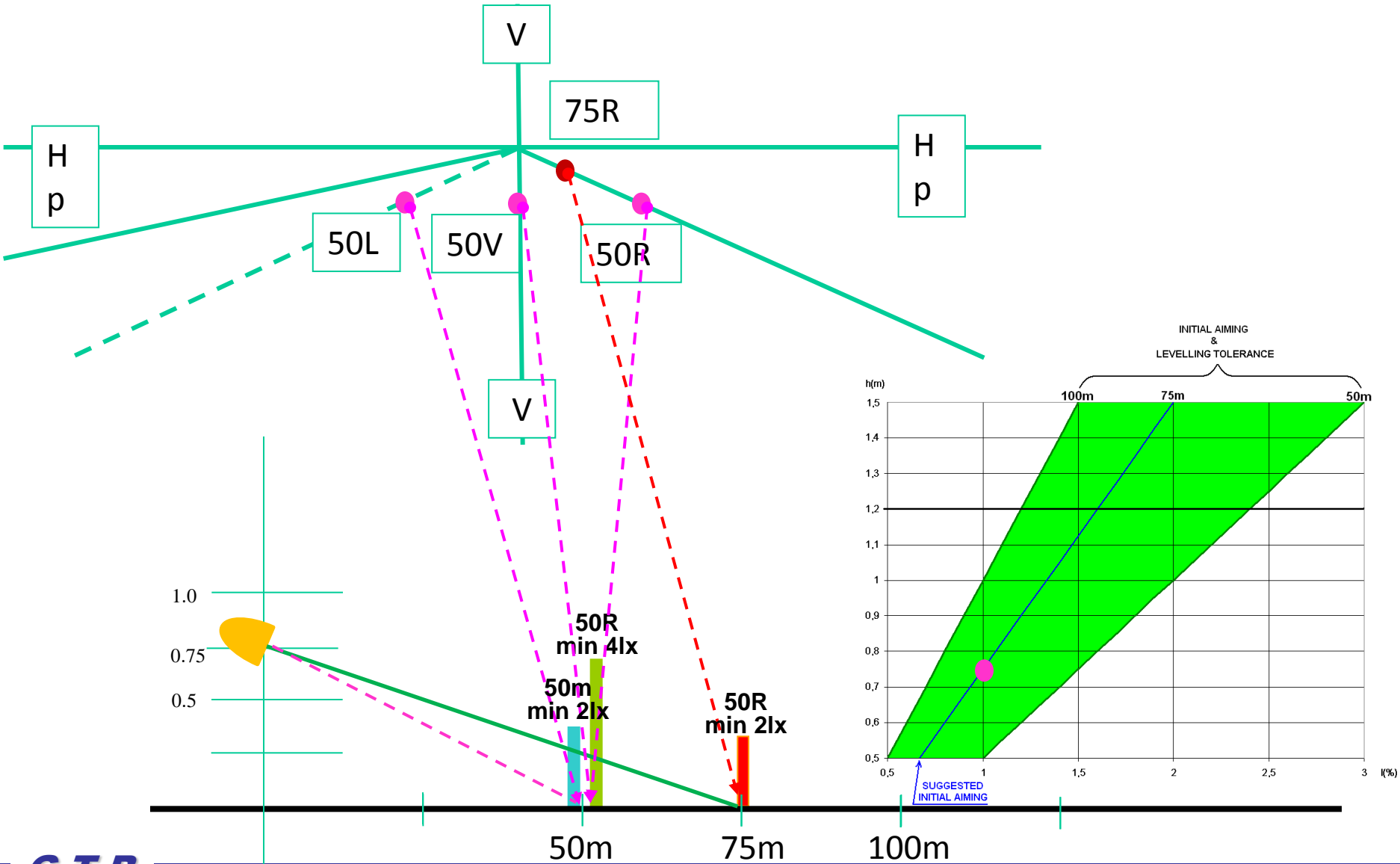

# ESSENCE OF POLISH PROPOSAL

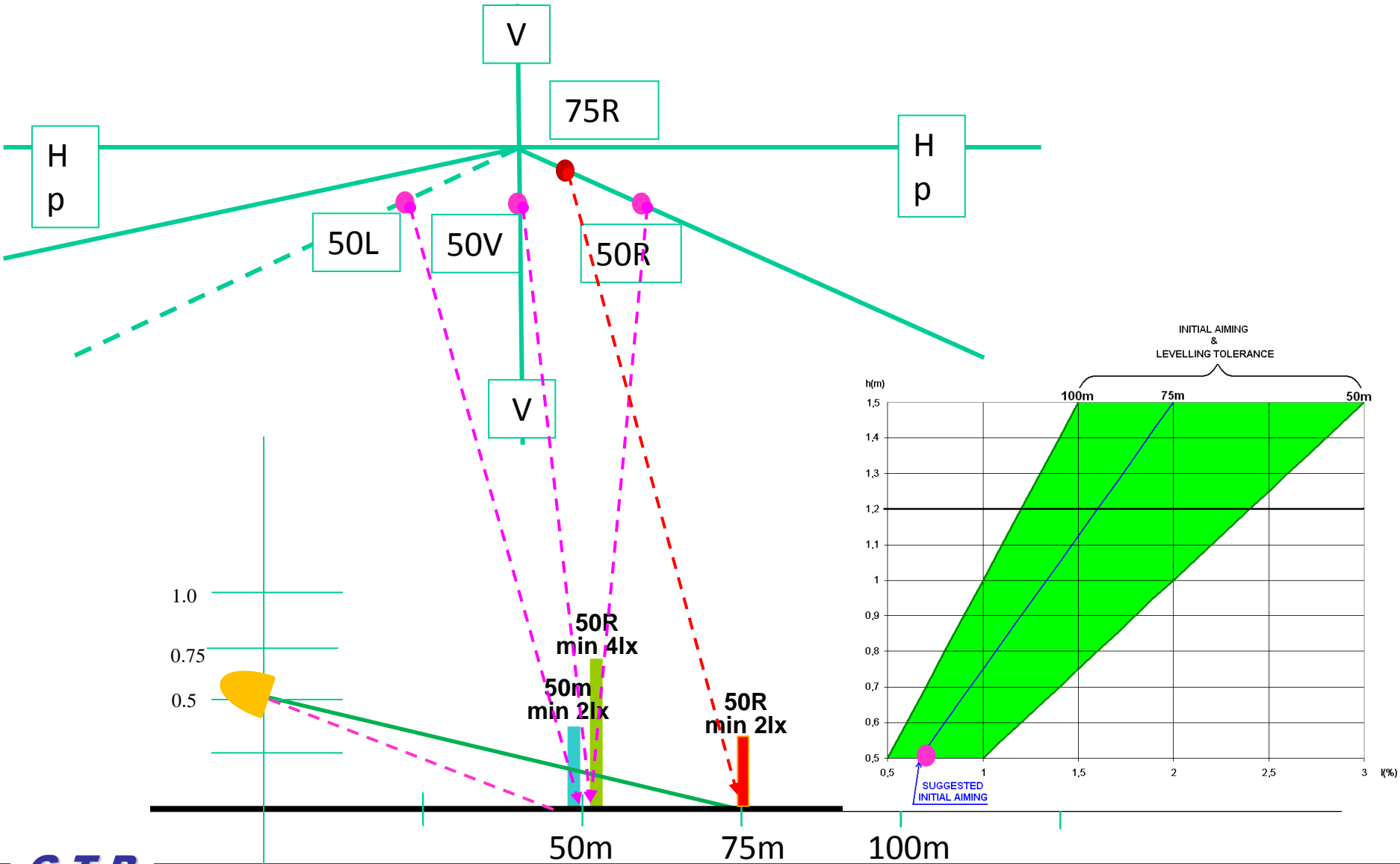

# ESSENCE OF POLISH PROPOSAL

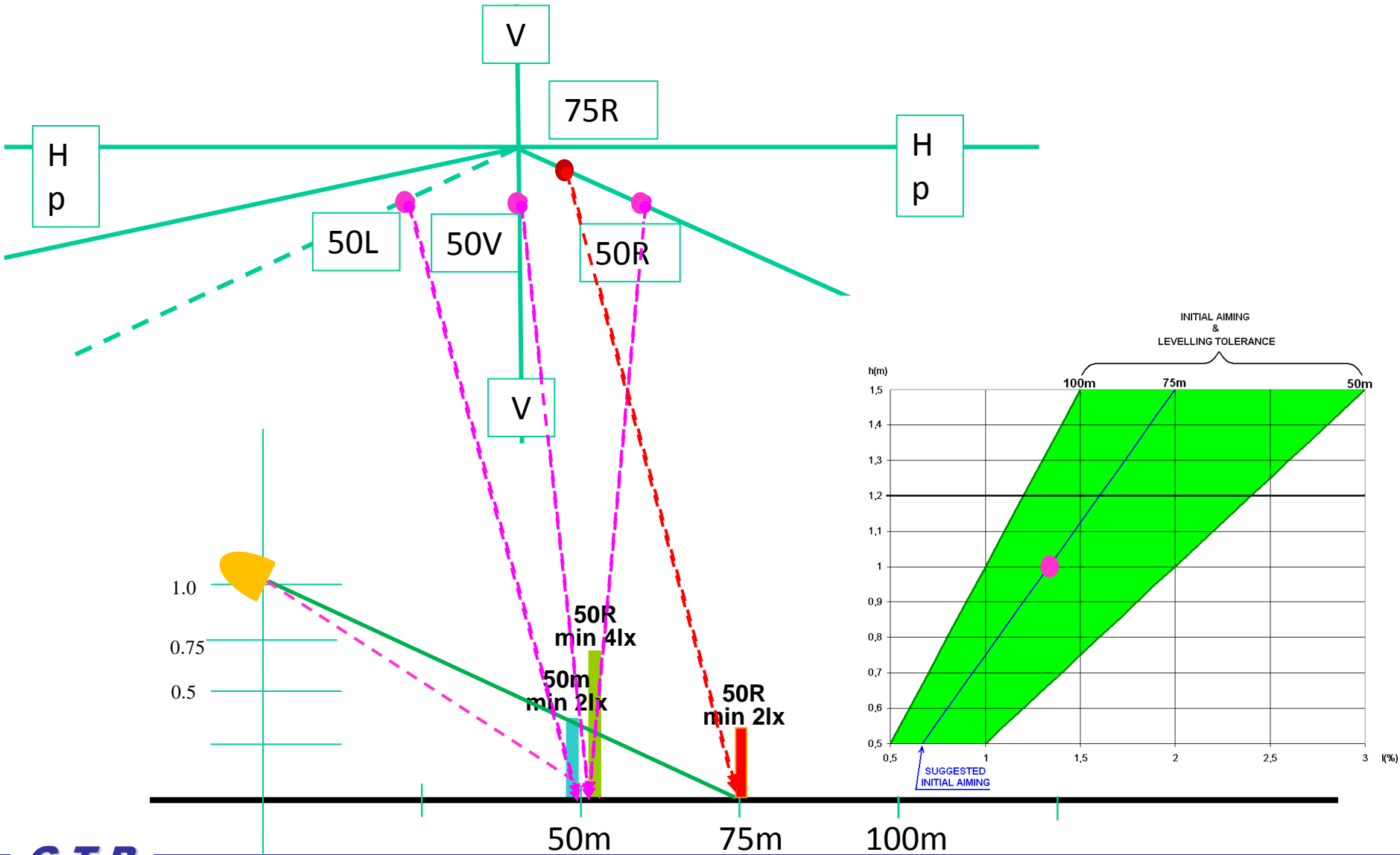

# ESSENCE OF POLISH PROPOSAL

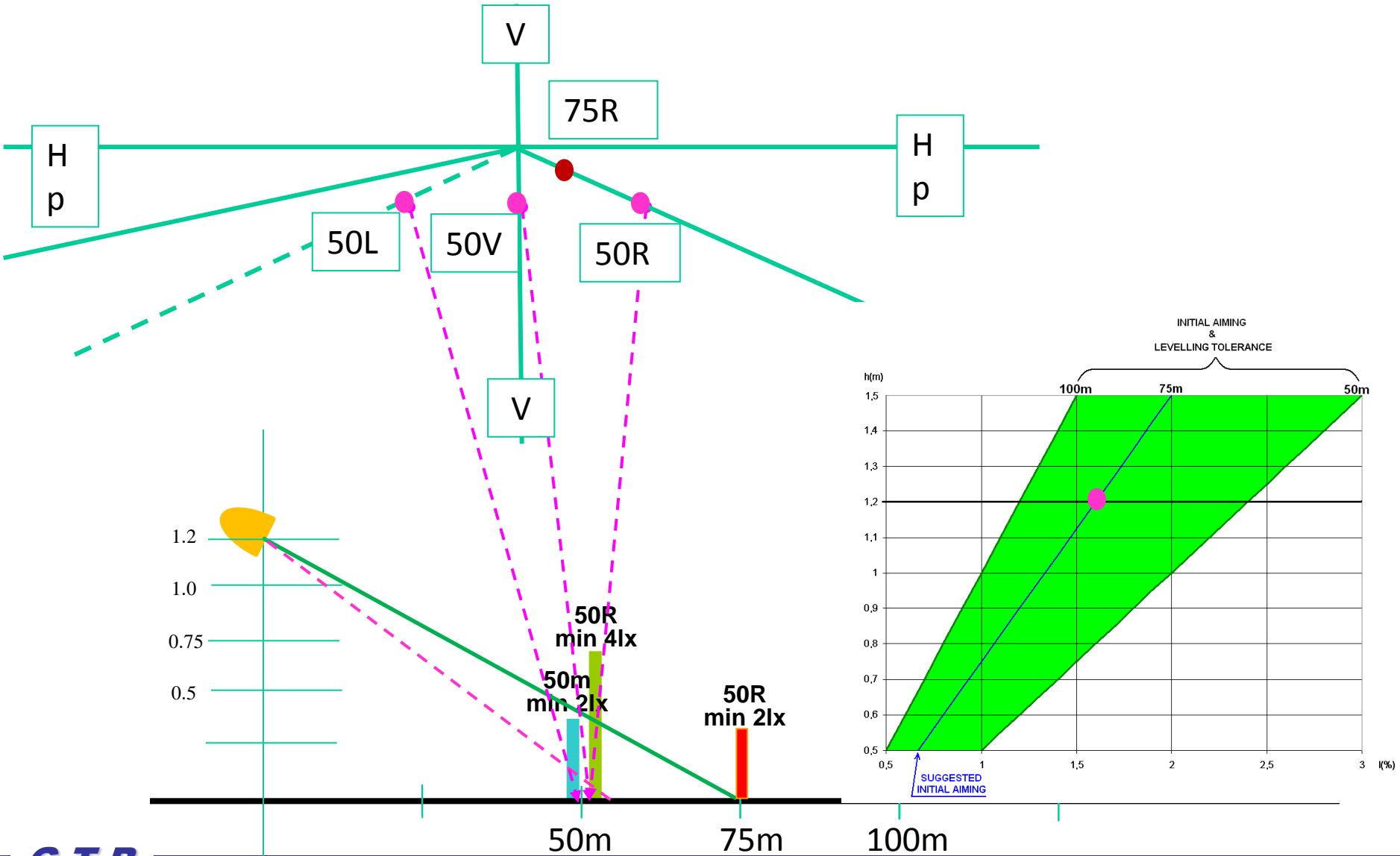

# GLARE

In Polish proposal is assumed that **over horizon** should not to be significantly more light then allowed by type approval headlamp regulation.

These requirements are based on research concerning disability glare.

Presently Reg.48 does not allow aiming higher than 0.5% down

INTERMEDIATE (NOT CONTROLLED) ZONE  
VALUES MORE THAN 1- 2lx@25m  
(625 - 1200 cd)

GLARE PROTECTION ZONE

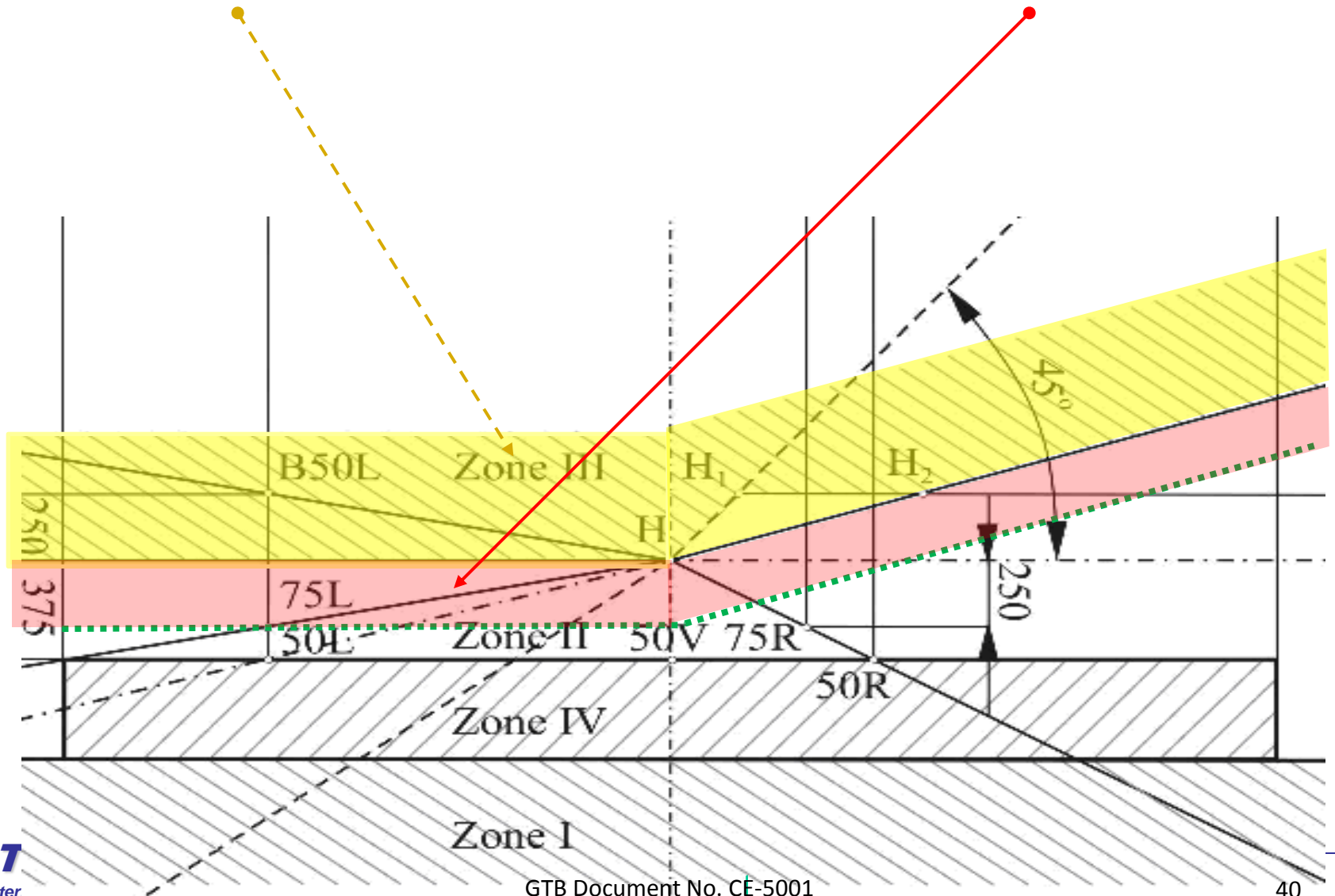



INTERMEDIATE (NOT CONTROLLED) ZONE  
VALUES MORE THAN 1- 2lx@25m  
(625 - 1200 cd)

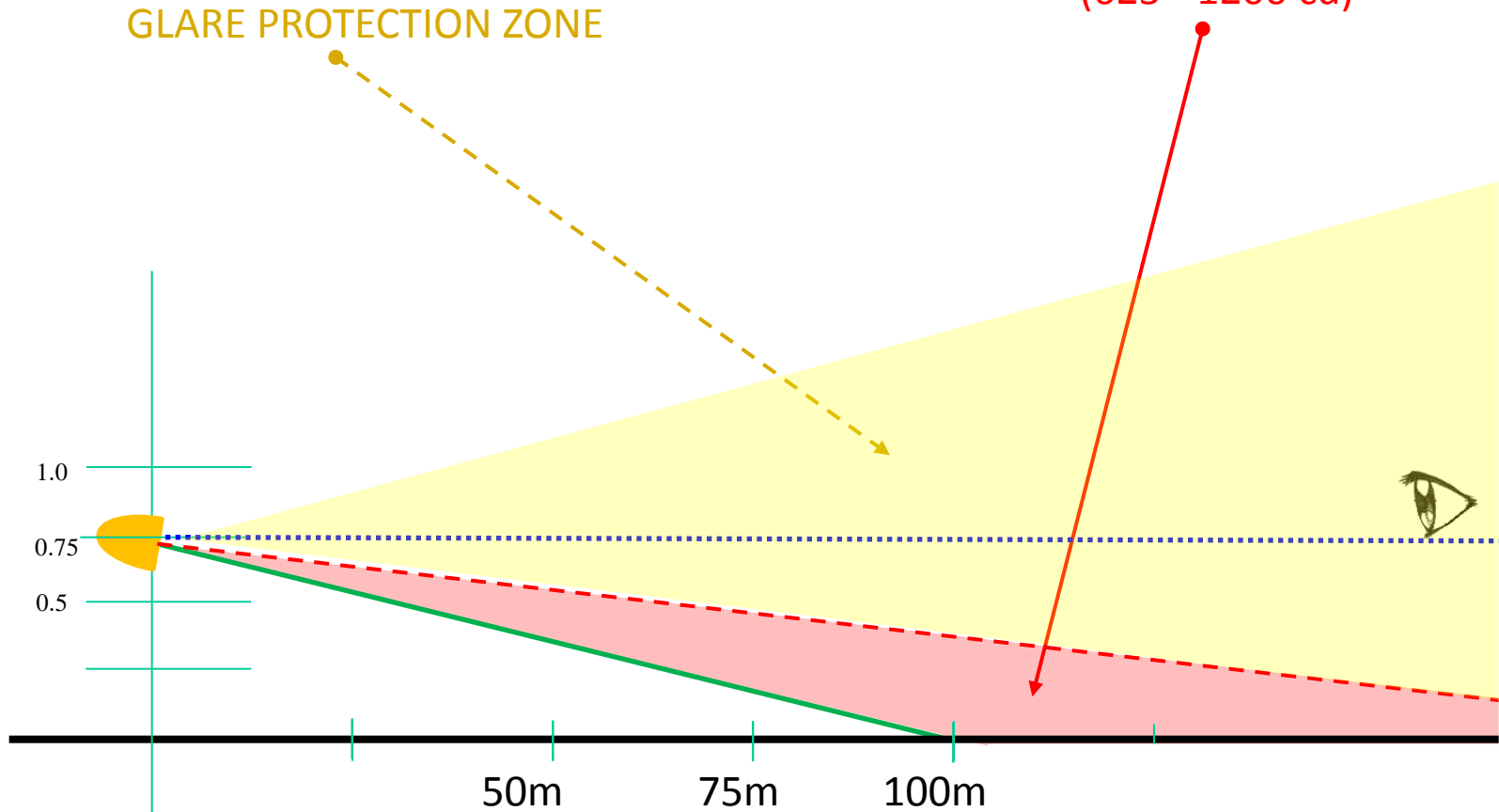

AIMING NOT HIGHER THAN 100m CUT-OFF & ROAD CROSSING

INTERMEDIATE (NOT CONTROLLED) ZONE

GLARE PROTECTION ZONE

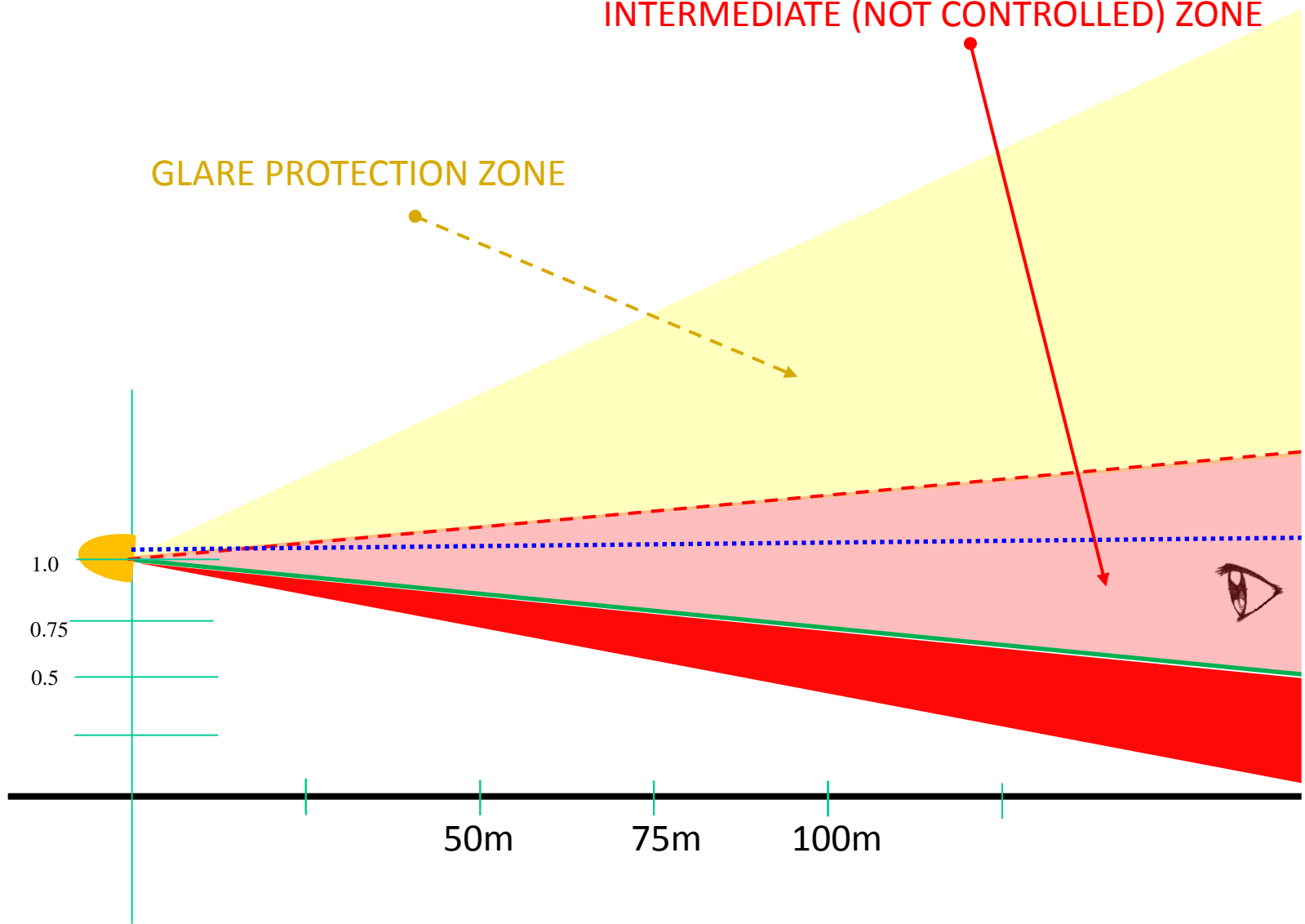

AIMING HIGHER AND NOT CONTROLLED

# Agenda

1. **GTB**

Introduction

2. **Poland**

Explanation of the background of the Polish proposal for R48

3. **GTB**

Literature Review

Night-time Field Test

Discussion

Comparison Klettwitz Outcome with Literature

Enrichment of Data by Calculation (CIE TC4-45)

4. **OICA**

Explanation of load conditions

5. **Joint GTB/Poland/OICA**

Conclusion

Suggestion

# Literature Studies regarding Glare and Visibility on Road Traffic

Carried out in GTB WG SVP for GTB TF CAVGS



Karl Manz  
Chairman GTB WG SVP ....

Geneva, 01 April 2014

**GTB**

*The International Automotive Lighting  
and Light Signalling Expert Group*

*Groupe de Travail "Bruxelles 1952"*

GTB Document No. CE-5001

44

# Literature studies regarding glare and visibility on road traffic

The current list contains more than 300 references, which are still under review and furthermore secondary literature is investigated.

In the following slides only a small number of references are highlighted!

- **Basic documents and further literature reviews are:**
- **Hanno Westermann, History and Scientific Back-up , Informal Document No. 30 (48th GRE, 9-12 April) 2002 (Concept Basis)**
- **Ernst-Olaf Rosenhahn; Headlamp Glare and Auto-Levelling: Degree of Influence and Future Outlook; Presentation at WG FL, Turin, January 25, 2011**
- **(Basis mainly investigations of TU Darmstadt)**
- **Mace, D., P. Garvey, R. Porter, R. Schwab, and W. Adrian, Countermeasures for Reducing the Effects of Headlight Glare, AAA Foundation for Traffic Safety, Washington, D.C., 2001.**
- **(More general view)**
- **Bullough J. D.; Skinner N. P.; Pysar R. M.; Radetzky L. C.; Smith A. M. ; Rea M. S.; Nighttime Glare and Driving Performance: Research Findings; DOT HS 811 043; NHTSA Washington DC, September 2008**
- **Hills B. L., PhD; Visibility under night driving conditions Part:**
  - **1. LABORATORY BACKGROUND AND THEORETICAL CONSIDERATIONS ; Lighting Research and Technology, 1975, Vol.7(3), pp.179-184**
  - **2. FIELD MEASUREMENTS USING DISC OBSTACLES AND A PEDESTRIAN DUMMY.; Lighting Research and Technology, 1975, Vol.7(4), pp.251-258**
  - **3. DERIVATION OF ( DELTA L,A) CHARACTERISTICS AND FACTORS IN THEIR APPLICATION.; Lighting Research and Technology, 1976, Vol.8(1), pp.11-26**

**Targosiński T. ; Testing of headlamps beam patterns using computerized device with photometrical image analysis ISAL 2007 Darmstadt 09.2007**

**- headlamps photometric characteristics and aiming in real road in use condition research.**

**Targosiński T.; Passing Beam Visibility Distance - Technical Possibilities, Legal Requirements and Road Safety, JOURNAL OF KONES Vol. 18, No. 4 2011 ss. 511-517**

**- Analysis of real road illumination distance possibilities and practice**

**Damasky, J., "Anforderungen an Kraftfahrzeugscheinwerfer"; Thesis D17, TU Darmstadt, 1995**

**FLANNAGAN, MICHAEL J. ; SIVAK, MICHAEL; SCHOETTLE, BRANDON; "BENEFITS OF HEADLAMP LEVELING AND CLEANING FOR CURRENT U.S. LOW BEAMS"; Report No. UMTRI-2007-46 NOVEMBER 2007**

**Wolfgang Huhn: Anforderungen an eine adaptive Lichtverteilung für Kraftfahrzeugscheinwerfer im Rahmen der ECE-Regelungen; Thesis, TU Darmstadt, 1999 .**

# Hanno Westermann, History and Scientific Back-up

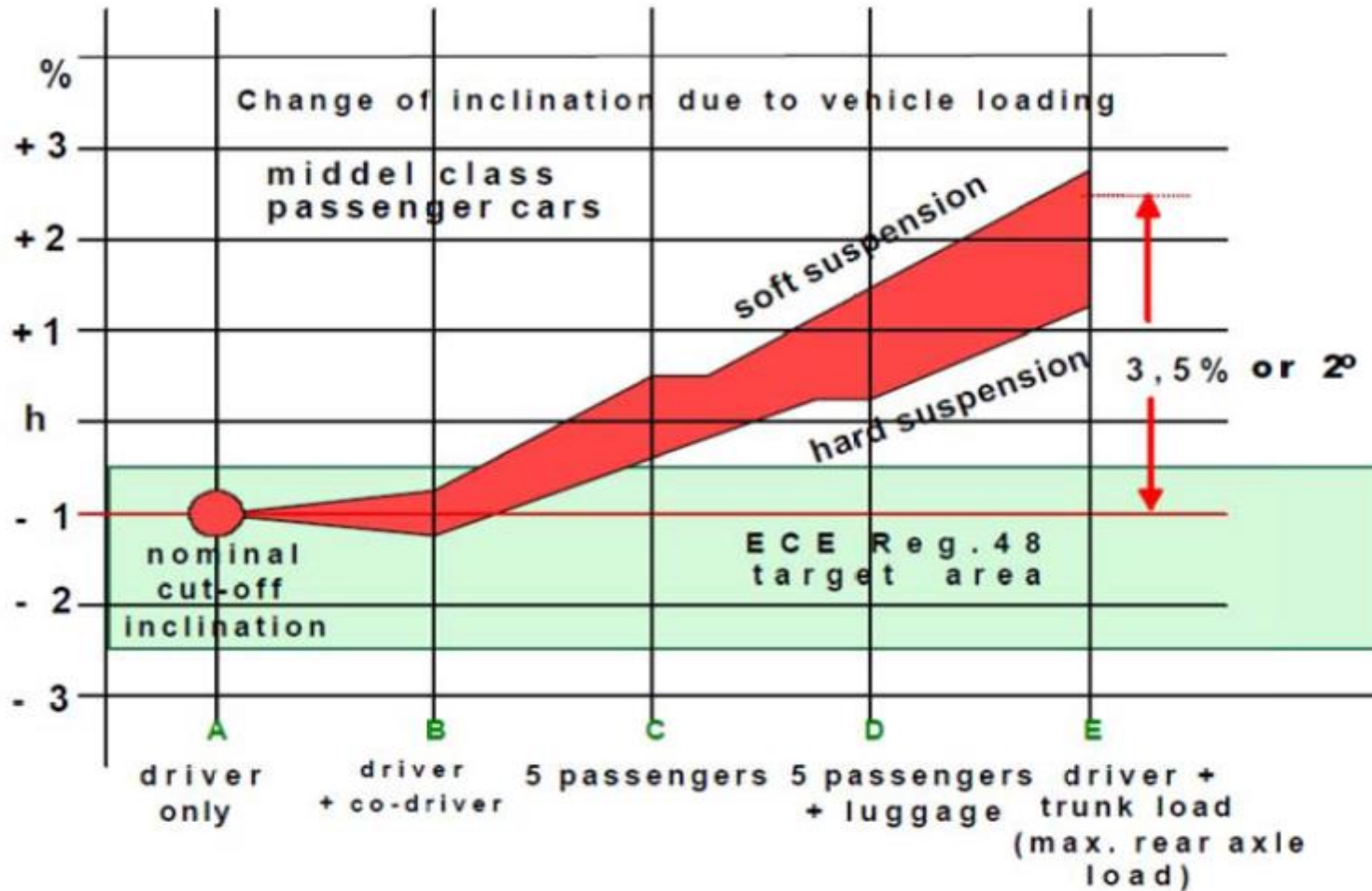



# Ernst-Olaf Rosenhahn; Headlamp Glare and Auto-Levelling

Estimation of Pitch Angle Frequency Spectrum caused by Vehicle Load

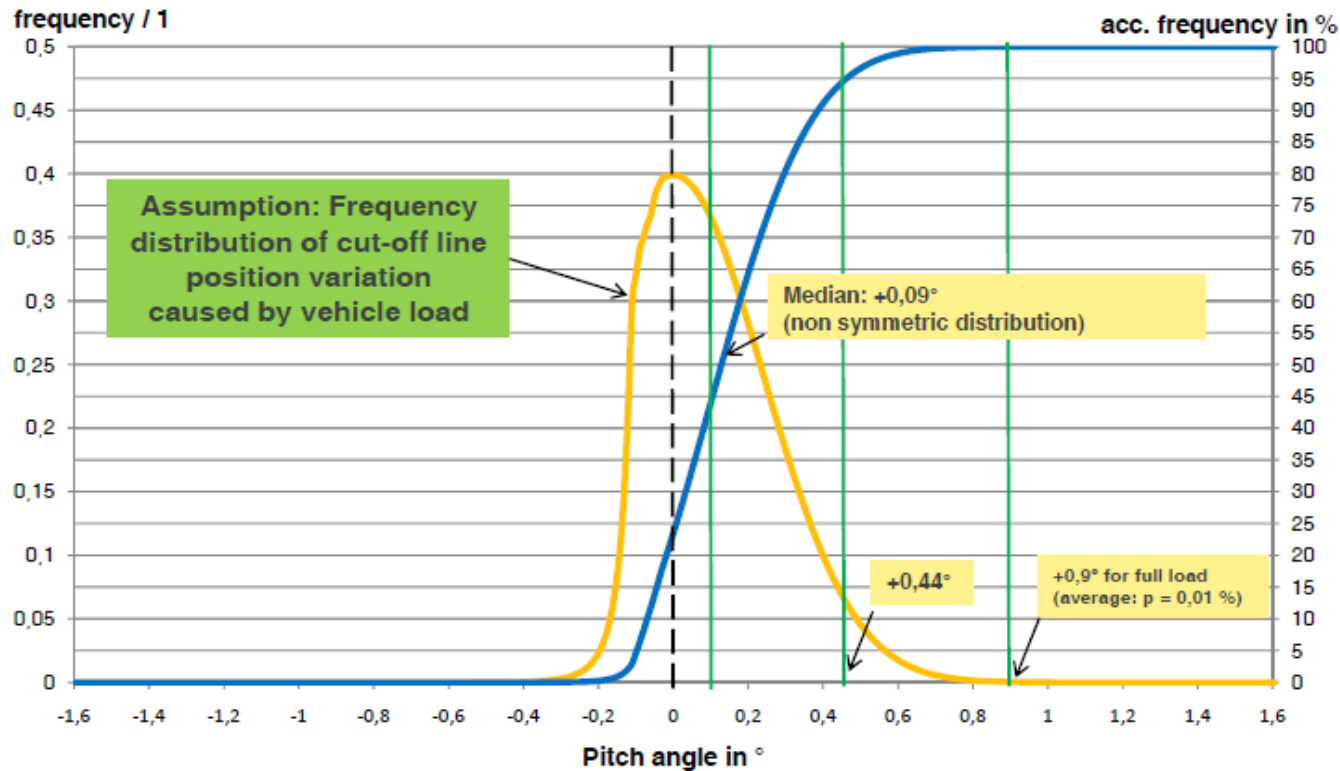

# Geoff Draper (Chairman); Performance Assessment Method for Vehicle Headlighting Systems CIE 188:2010

The Work in CIE TC4-45 continues under the chairmanship of Gert Langhammer

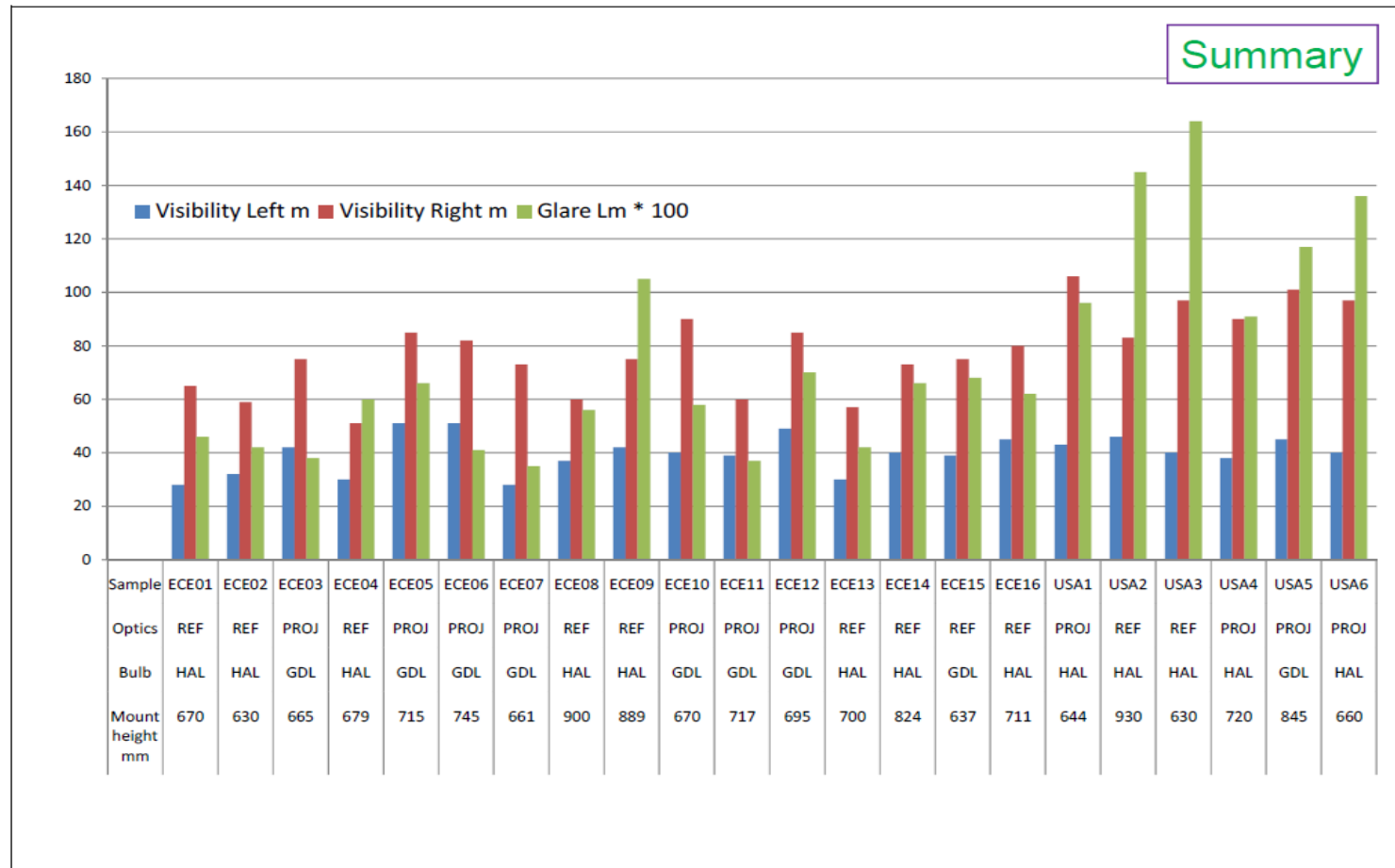

Geoff Draper (Chairman); *Pedestrian Visibility - Low Beam Optimization to Reduce Night-time Fatalities* ; SAE SURFACE VEHICLE INFORMATION REPORT J2829 - 2011-02-24;

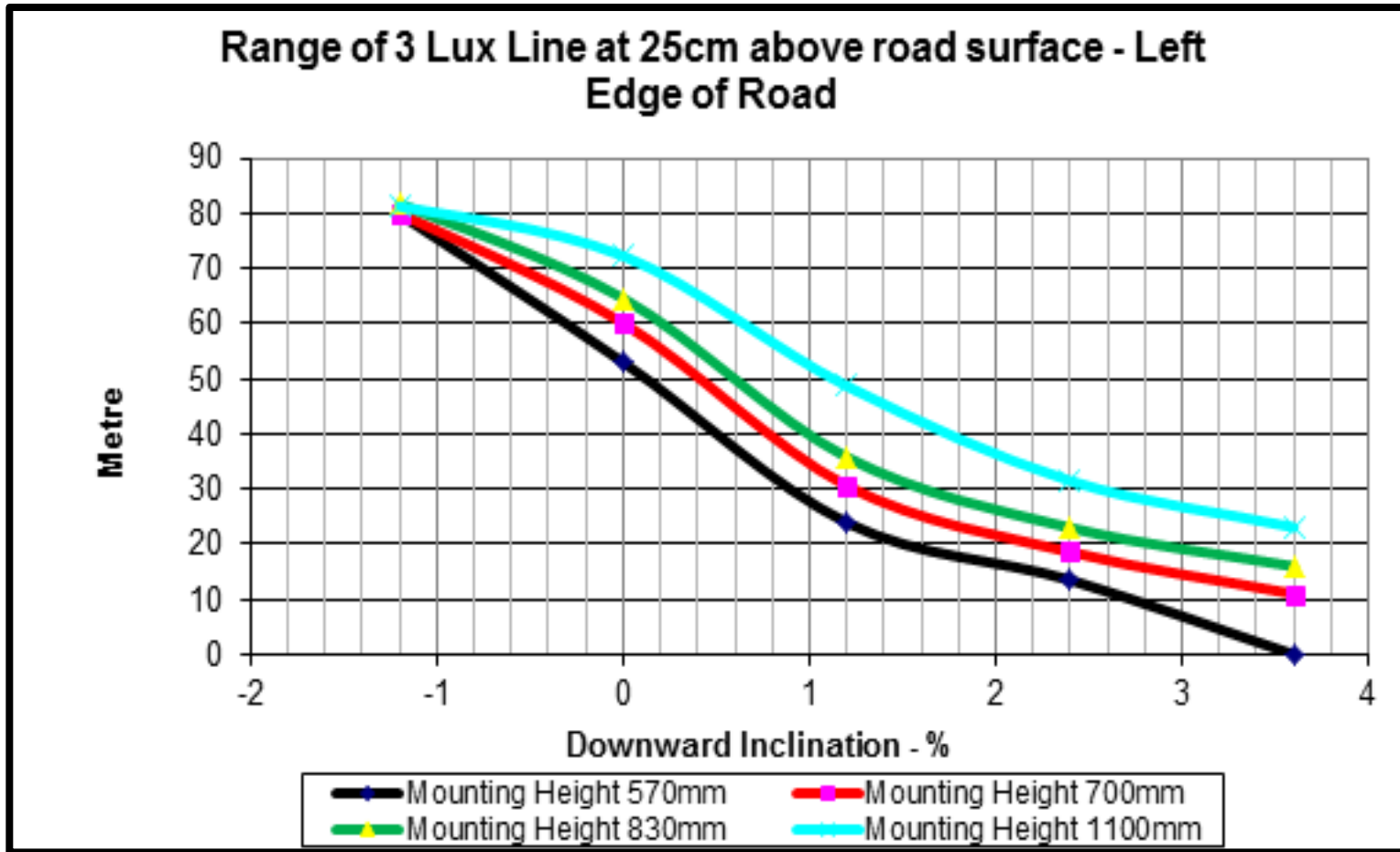

# Geoff Draper; *Pedestrian Visibility*

## Weighted Flux in Glare Zone Related to Headlamp Mounting Height

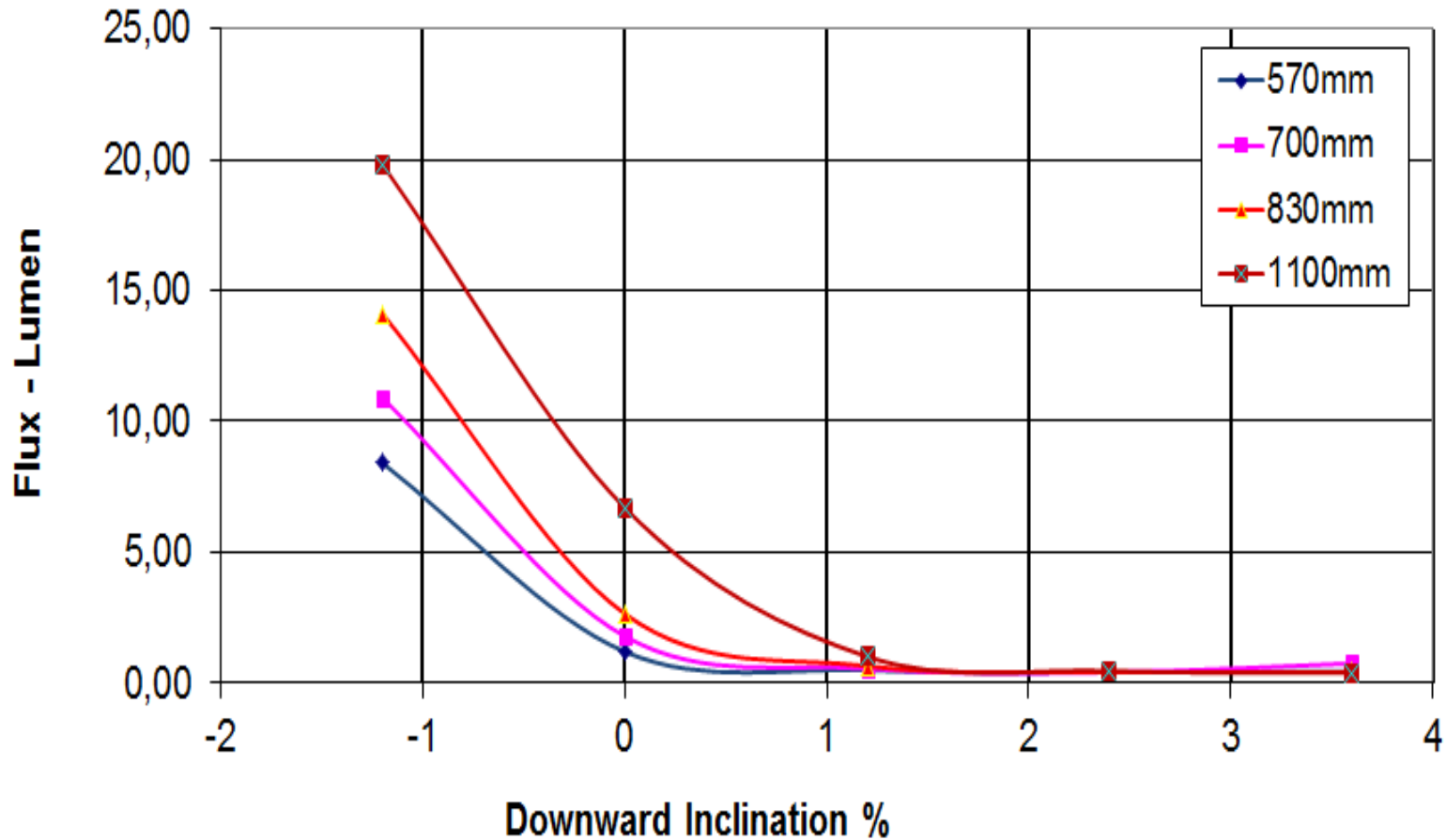

**Downward inclination (pitch angle) and  
mounting height of head lamps  
control visibility distance and glare  
in the opposite direction!**

# Glare

Adrian, Werner; "Proceedings of the First International Symposium on Glare";  
New York: Lighting Research Institute;

Schmidt-Clausen, H. J. and Bindels, J. T. H. ; "Assessment of discomfort glare in motor vehicle lighting." ; *Lighting Research and Technology*, 6(2), 79-88.

Vos Johannes J. ; Reflections on glare; *Lighting Res. Technol.* 35,2 (2003) pp. 163-176

Gibbons Ronald B. ; Edwards Christopher J.; A Review of Disability and Discomfort Glare Research and Future Direction, Submitted for Presentation at the TRB Biennial Visibility Symposium 2007

Von Hoffmann Alexander; Lichttechnische Anforderungen an adaptive Kraftfahrzeugscheinwerfer für trockene und nasse Fahrbahnoberflächen; Publikationsreihe Nr. 4; Thesis TU Ilmenau 2003

Stephan Völker; Hell- und Kontrastempfindung - ein Beitrag zur Entwicklung von Zielfunktionen für die Auslegung von Kraftfahrzeug-Scheinwerfern; Habilitationsschrift der Universität Paderborn Fakultät für Maschinenbau; Paderborn 2006

## Special item for Road Traffic - **SMALL GLARE ANGLES**

Hartmann, E.; Ucke, Ch. ; "effect of size of glare source on disability glare at small glare angles"; NASA technical translation, NASA TT F-15,581; national aeronautics and space administration Washington, D.C. 20546 MAY 1974; Lichttechnik 26 (1974) p. 20 - 23

Blendung durch kleine Lichtquellen hoher Leuchtdichte im peripheren Gesichtsfeld / Paul W. Schmits; Berlin, Techn. Univ., Diss., 1988

Finsterwalder, Josef (1991). Untersuchungen zur Physiologischen blendung bei sehr Kleinen Blendwinkeln. ("Investigations on Disability Glare at Very Small Glare Angles"). Ph.D. thesis at the Faculty of Physics of the Ludwig-Maxililian University, Munich, Germany.

Sprute, Jan Holger; "Entwicklung lichttechnischer Kriterien zur Blendungsminimierung von adaptiven Fernlichtsystemen,,: Dissertation D17 , Darmstadt 2012

## Disability Glare:

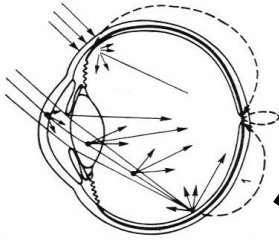

$$L_{seq} = K \cdot \frac{E_G}{\Theta^2}$$

$$C = \frac{(L_T + L_{seq}) - (L_B + L_{seq})}{(L_B + L_{seq})} = \frac{(L_T - L_B)}{(L_B + L_{seq})}$$

$L_{seq}$  equivalent veiling luminance;

$E_G$  Illuminance at the eye

$\Theta$  Glare angle between fixation point and glare source (Holladay Exponent 2)

$k$  Proportional factor which depends on the age of the observer, typical value 9.2

$L_T$  Luminance of the target;  $L_B$  surrounding luminance (Adaptation level)



## Disability Glare:

For practical reasons, it is very helpful to describe disability glare as the so called threshold increment TI according to CIE.

TI describes the percentage with which the threshold luminance of the target must be increased to compensate the glare effect.

$$TI = 65 \cdot \frac{L_{seq}}{L_B^{0,8}} \cdot [\%]$$

For further calculations it is better to define a “Threshold Increment Factor” TIF as:

$$TIF = 1 + TI / 100$$

Which describe directly the amount of increase to guarantee the visibility of the target.

$$TIF = 1 + 0.65 \cdot \frac{L_{seq}}{L_B^{0,8}}$$

For discomfort glare under road traffic geometry the formula from Schmidt-Clausen, H. J. and Bindels, J. T. H. is very useful:

$$W = 5.0 - 2.0 \text{LOG}_{10} \frac{E_i}{0.003 * \left( 1 + \sqrt{\frac{L_a}{0.04}} \right) * \theta_{\max}^{0.46}}$$

$W$  = mean value on deBoer's scale

$E_i$  = Average level of illumination directed towards the observer's eye from the headlamps (lux)

$\theta_{\max}$  = glare angle between observer's line of site and the headlamps at location where maximum illumination occurs (minutes)

$L_a$  = adaptation luminance ( $\text{cd}/\text{m}^2$ )

# Disability versus Discomfort for different Glare Levels

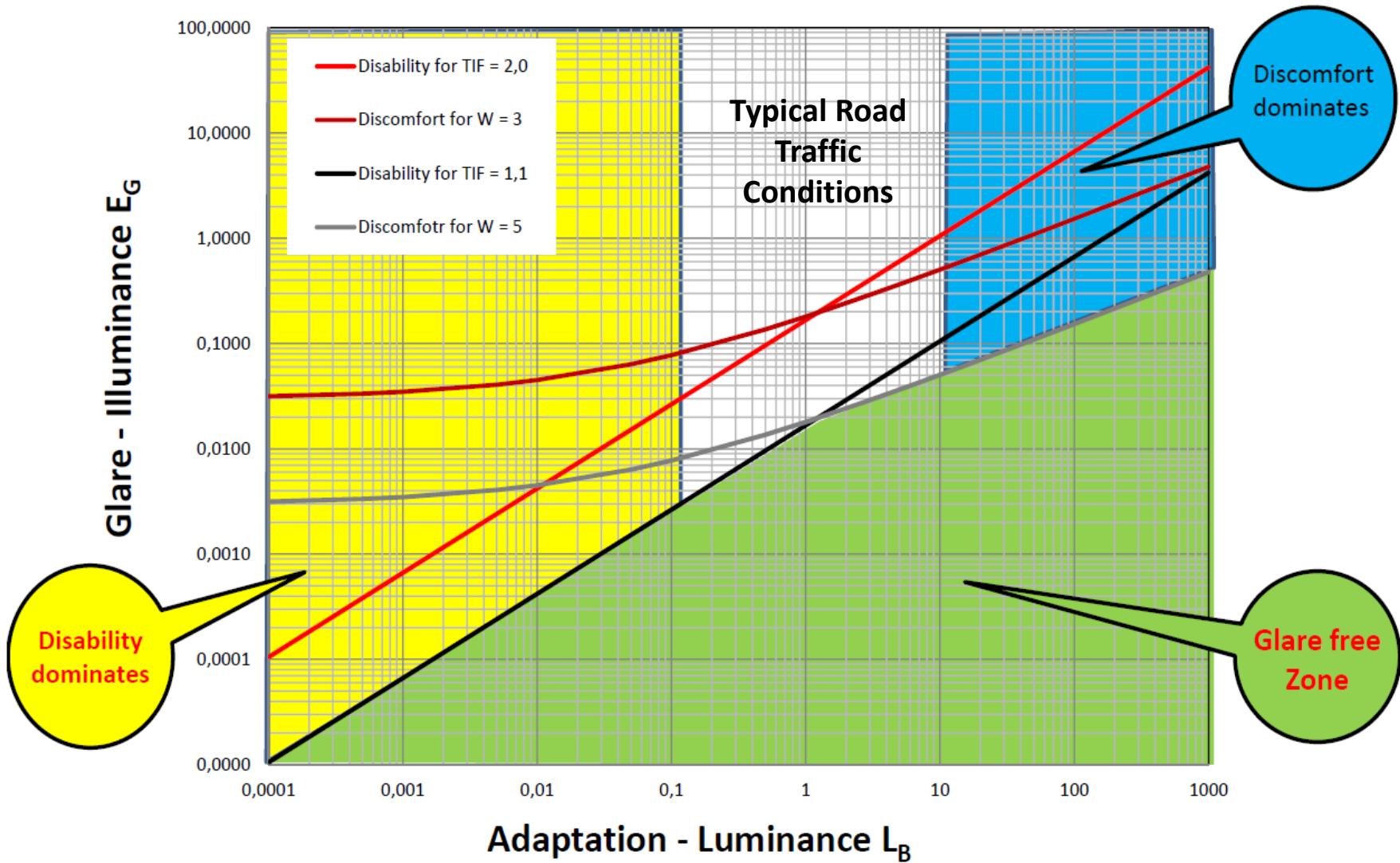

## Conclusion:

At typical road traffic conditions at night we must not differentiate between disability and discomfort glare, because

if we feel glared we are objectively glared!

That means, we can simply speak about glare and the terms disability and discomfort glare are related only to the methods to evaluate or to measure this phenomena.

# Disability glare and visibility of pedestrians on straight traffic roads

Some input from SAE TF Pedestrian Protection;



Road scene with targets and a glare source

By the influence of glare the value for  $E_{\text{required}}$  became higher:

$$E_{\text{required+glare}} = TIF \cdot E_{\text{required}}$$

## Walter Kosmatka and Rainer Rattunde Criteria:

$$E_{\text{required}} = L_{\text{threshold}} \times F_{\text{expectancy}} \times F_{\text{Vad.}} \times F_{\text{adaptation/glare}} \times F_{\text{age}} / (r)$$

determined a value for  $E_{\text{required}} = 3\text{lx}$  to produce on the target a minimum luminance necessary for the detection of that obstacle.

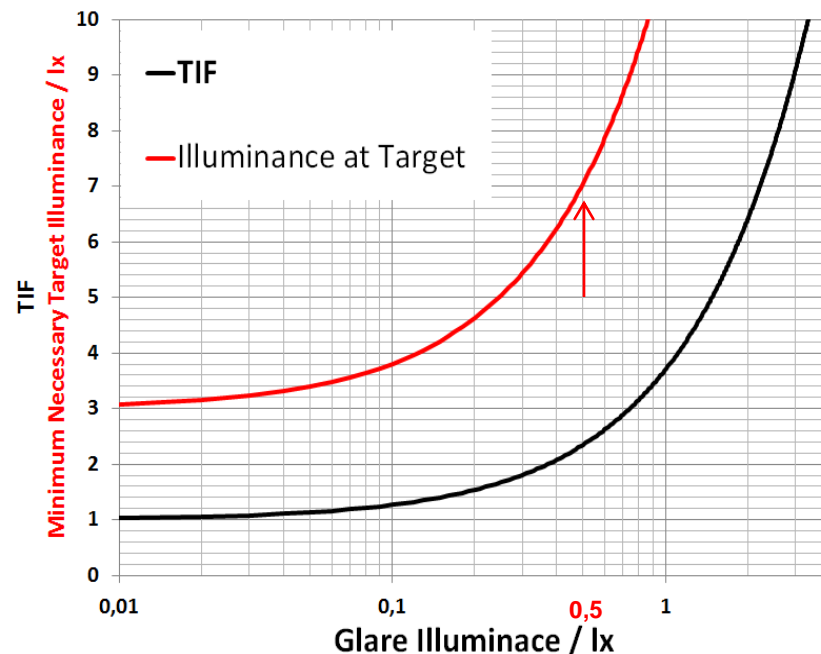

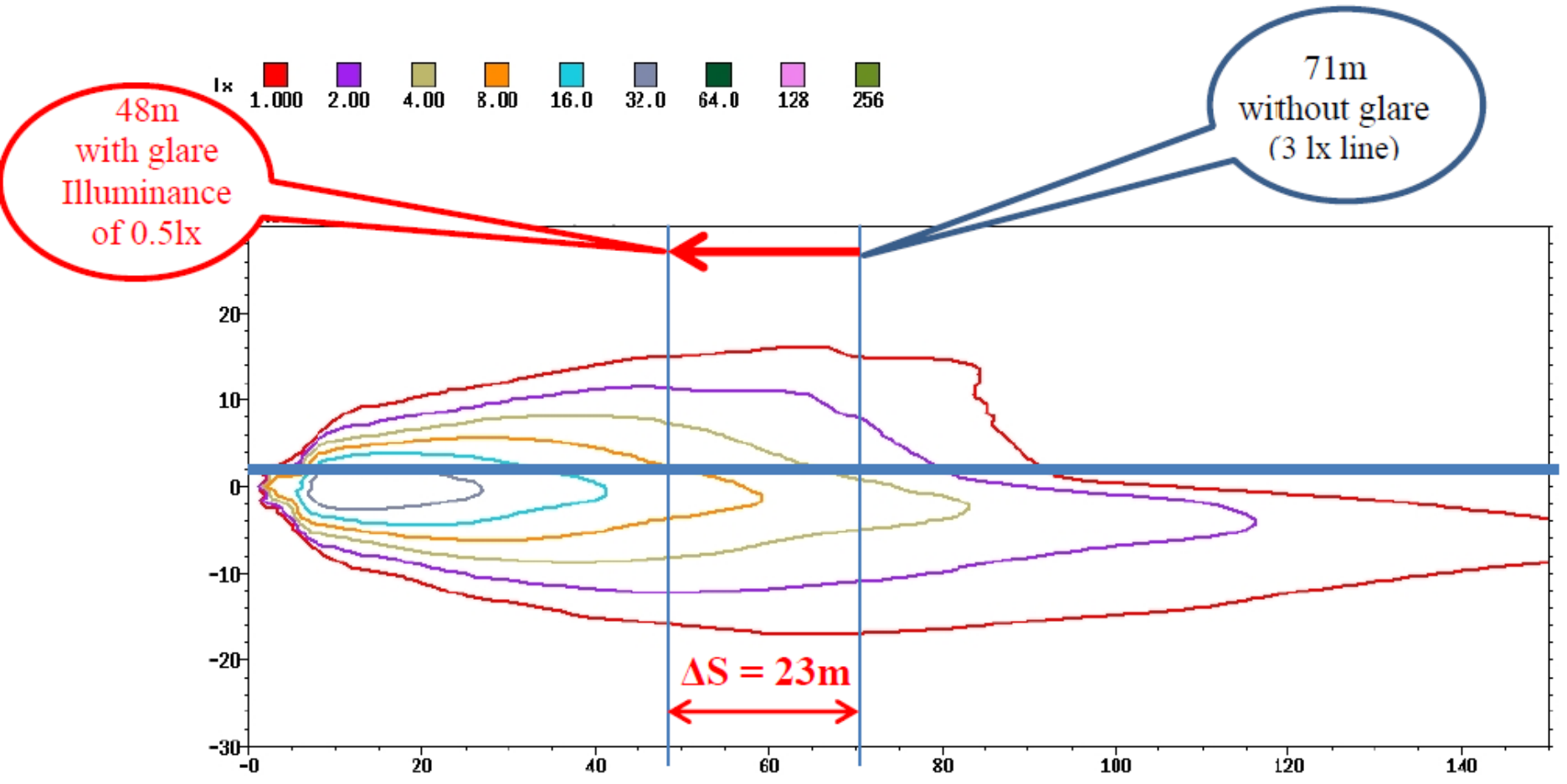

H7 head lamp (H7 – Diagram: private communication from Rainer Neumann)

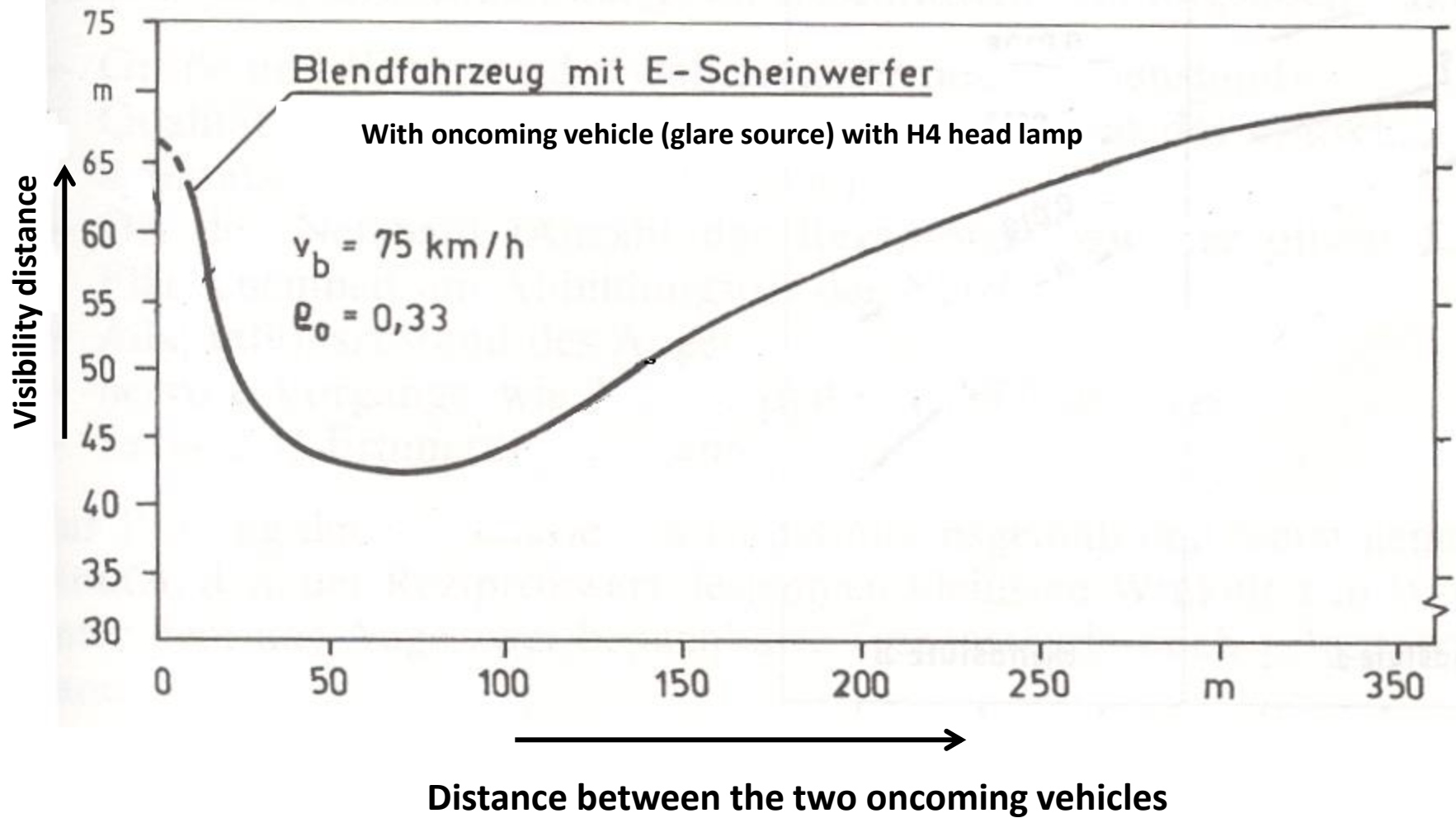

Picture detail from : Martin Eckert, *Lichttechnik und optische Wahrnehmungssicherheit im Straßenverkehr*, Verlag Technik Berlin, München 1993, p.63

**Glare reduces the visibility and  
therefore the visibility distance;**

**Visibility distance is a key factor  
for safe driving!**



# Dynamic (Transient) Glare

Murray, I.; Feather, J.; Carden, D.; "Dynamic Discomfort Glare and Driver Fatigue"; The Lighting Journal, July August 2002, pp 20 - 23

Lenhert, P. ; "Disability and Discomfort Glare under Dynamic Conditions- The Effect of Glare Stimuli on Human Vision"; PAL 2001 Symposium, Darmstadt University of Technology, 2001. Pp 582-592

Diem, Carsten ; "Dynamic glare"; AFS-research report FO-xx/98, TU-Darmstadt, 1998

van Derlofske, Chen, Bullough and Akashy ; Headlight Glare Exposure and Recovery, SAE Paper 2005-01-1573; SAE World Congress Detroit 2005

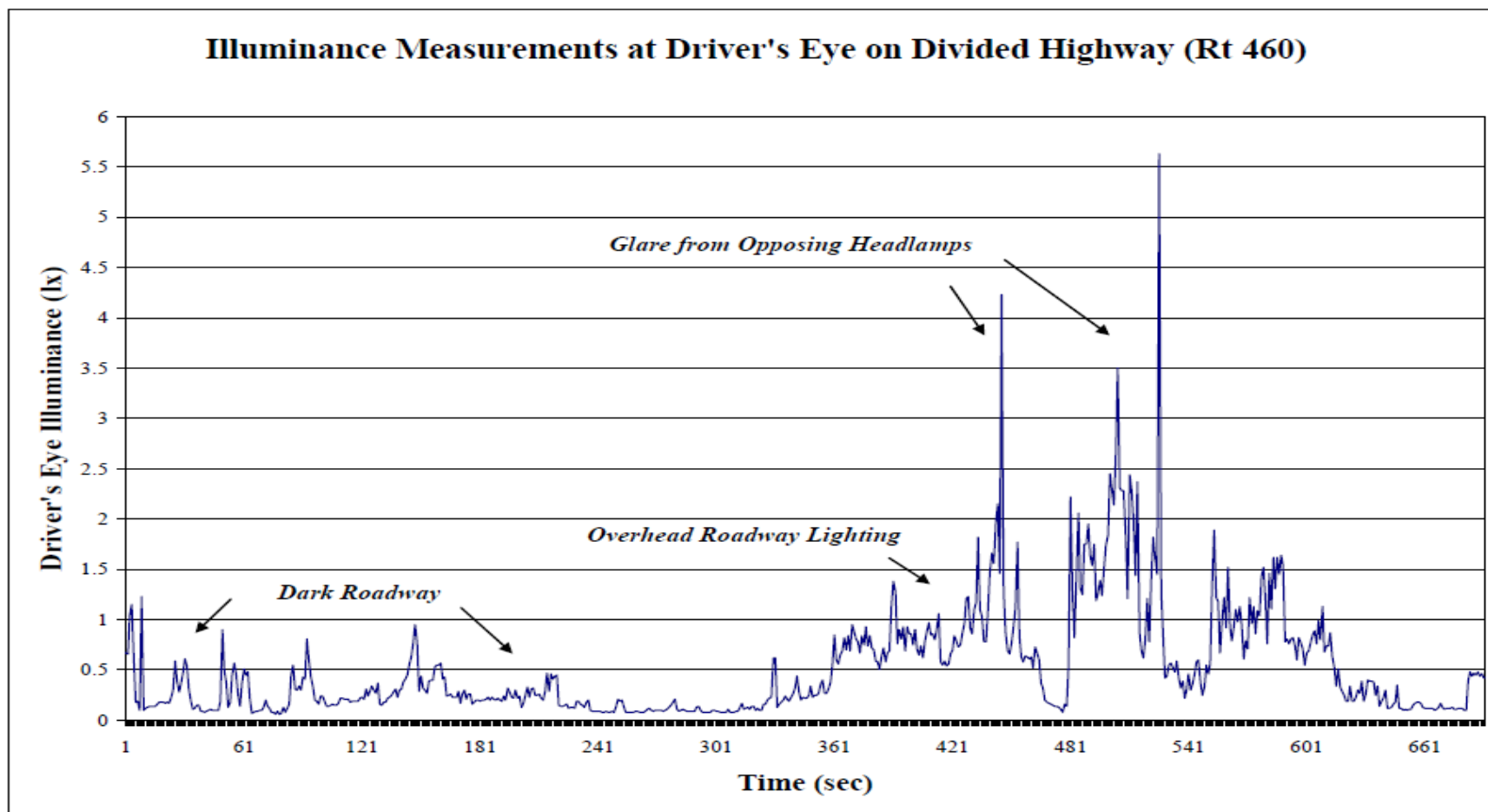

*Illuminance Readings Taken on Route 460 at Night with and without Overhead Lighting and Glare. from Jason Clark*

Lenhert, P.

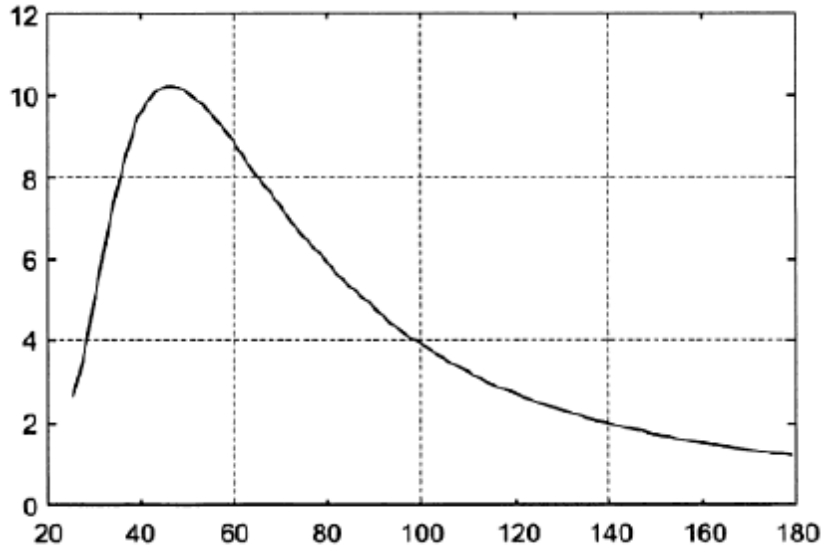

*Maximum Glare Pulse Illuminance [lx] at the maximum pitch angle as a function of the distance between two meeting vehicles*

van Derlofske, Chen, Bullough and Akashy

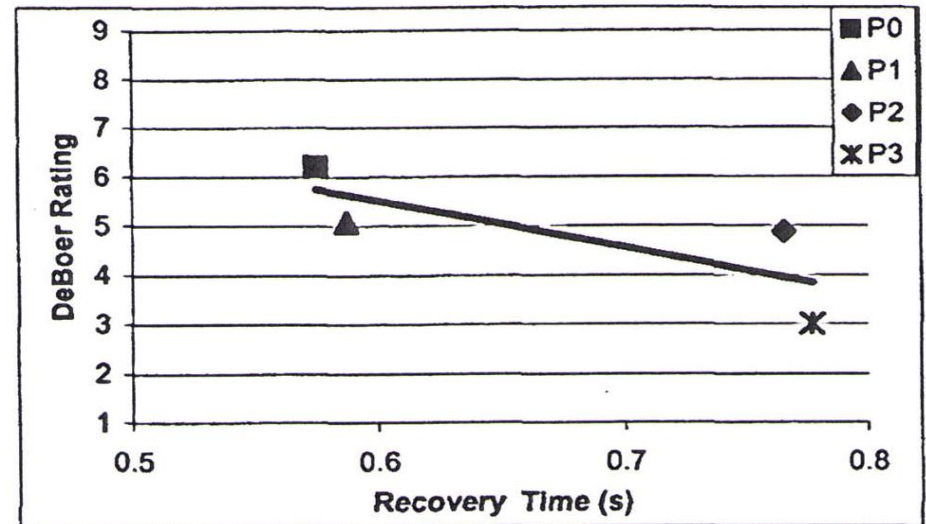

Evaluation of correlation between rating of discomfort and recovery time

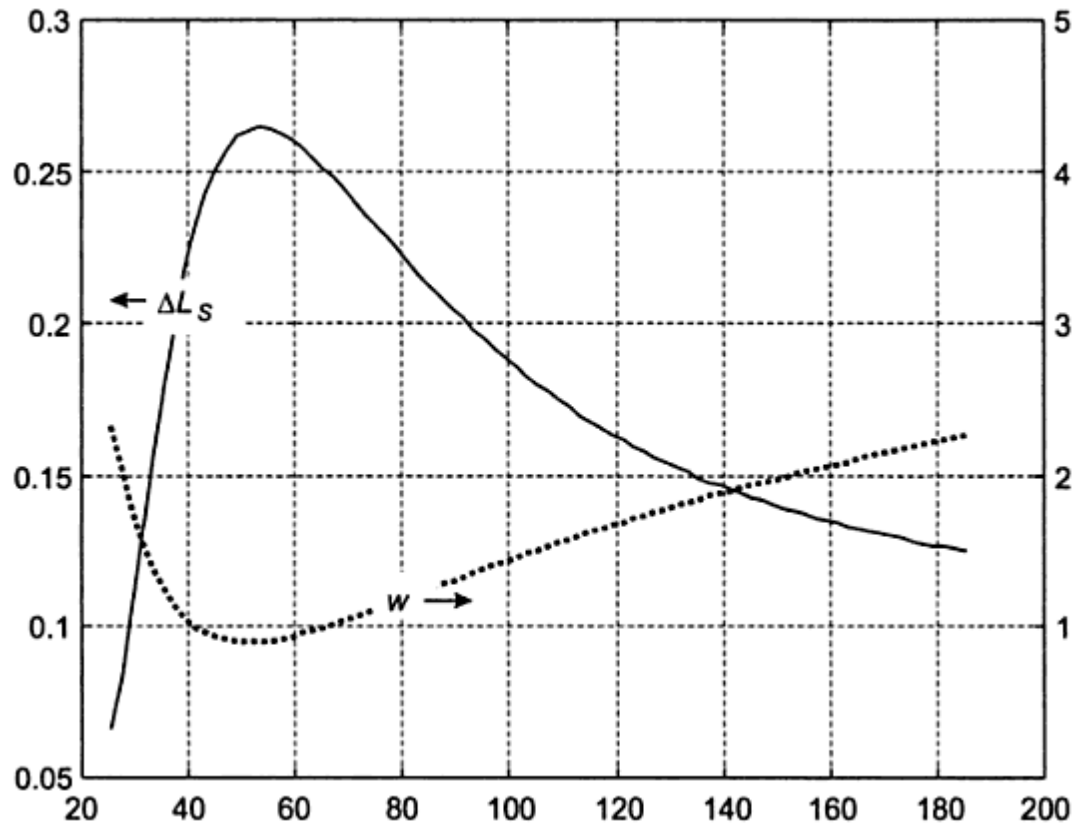

*Distance between two oncoming vehicles*

This diagram shows the glare situation of driver as a function of the distance to the oncoming vehicle.

# A Result of the Klettwitz Study:

## Evaluation of Illuminance

- Maximum of illuminance  $E_{v\_max}$
- Exposure in 400 m (Sprute): 80 km/h → 18 sec exposure time

$$H_v = \int_0^{18} E_v(t) dt$$

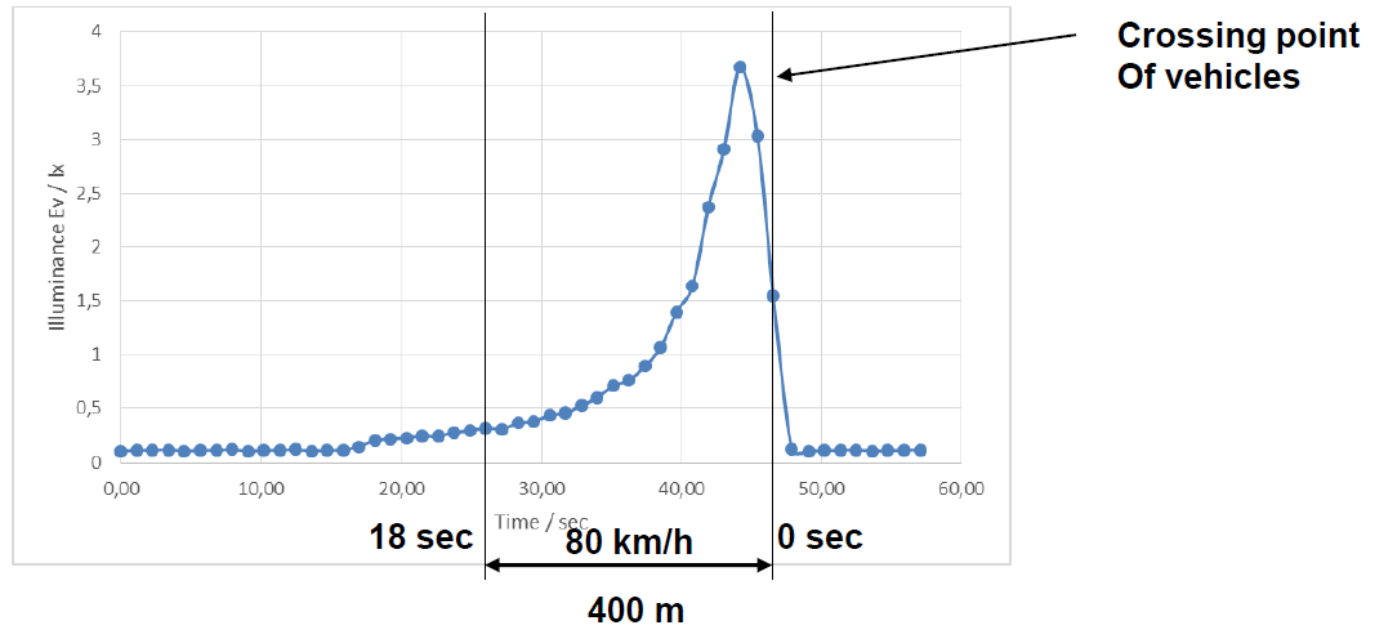

# Accident Studies:

# Risk factors for road traffic injuries



## Risk factors influencing crash involvement

- inappropriate and excessive speed;
- presence of alcohol, medicinal or recreational drugs;
- fatigue;
- being a young male;
- having youths driving in the same car;
- being a vulnerable road user in urban and residential areas;
- travelling in darkness;
- vehicle factors – such as braking, handling and maintenance;
- defects in road design, layout and maintenance, which can also lead to unsafe behaviour by road users;
- inadequate visibility because of environmental factors (making it hard to detect vehicles and other road users);
- poor eyesight of road users.

# Road Safety Research Report No. 80

## Analysis of the On the Spot (OTS) Road Accident Database

Page 30

Visual impairment or obscuration	Cross from behind parked car	21
	View obscured from window	18
	Glare from sun	20
	Glare from headlights	5
	Surroundings obscured by stationary or parked car	43
	Surroundings obscured by moving vehicle	21
	Obscuration due to weather	5
	Failure to see pedestrian in blind spot	1

Department for Transport  
Great Minster House  
76 Marsham Street  
London SW1P 4DR  
Telephone 020 7944 8300  
Web site [www.dft.gov.uk](http://www.dft.gov.uk)

Hannah Mansfield and Alex Bunting,  
QinetiQ Ltd  
Marieke Martens and Richard van der Horst,  
TNO Human Factors

February 2008

© QinetiQ Ltd, 2008

Department for Transport: London

**GTB**

The International Automotive Lighting  
and Light Signalling Expert Group

Groupe de Travail "Bruxelles 1952"

GTB Document No. CE-5001

72



# Synthesis of Human Factors Research on Older Drivers and Highway Safety

## Volume I: Older Driver Research Synthesis

U. S. Department of Transportation Federal Highway Administration; Publication No. FHWA-RD-97-094

Page 16 ...

Despite evidence that glare sensitivity and glare recovery are important age-related visual changes, evidence is sparse that glare is associated with actual driving performance.

Burg's (1967) study and the reanalysis by Hills and Burg (1977) **demonstrated a significant relationship between glare recovery rate and crash rate**; however, **the relationship was relatively weak.**

**Headlight glare was attributed as a possible “environmental” factor in approximately 2.3 percent of night accidents** in another study (Indiana University, 1975) cited in Mortimer, 1988).

**Glare was mentioned as a factor in 3 of 30 crashes** where drivers ran off of the road, in a study by Boyce, Hochmuth, Meneguzzer, and Mortimer (1987; cited in Mortimer, 1988).

Further, **glare was named as a factor in 30 of 231 crashes in which adverse environment was involved** (Sabey and Stoughton, 1975; cited in Mortimer, 1988).

**The time needed to recover from glare** was also included in Burg's (1971) study, and was found to **correlate weakly with accident rates**.

**Other studies, however, have failed to find a direct relationship between glare sensitivity measures and driving performance** (Shinar et al., 1977; Wolbarsht, 1977; Burg, 1967; Owsley et al., 1991)

**Mortimer, R. G. ; "Headlamp performance factors affecting the visibility of older drivers in night driving."; In Transportation in an Aging Society: Improving Mobility and Safety for Older Persons, Special Report 218, Vol. 2, pp. 379-403. Committee for the Study on Improving Mobility and Safety for Older Persons, Transportation Research Board, Washington, DC, (1988)**

## Investigation from the Light.Sight.Safety Group:

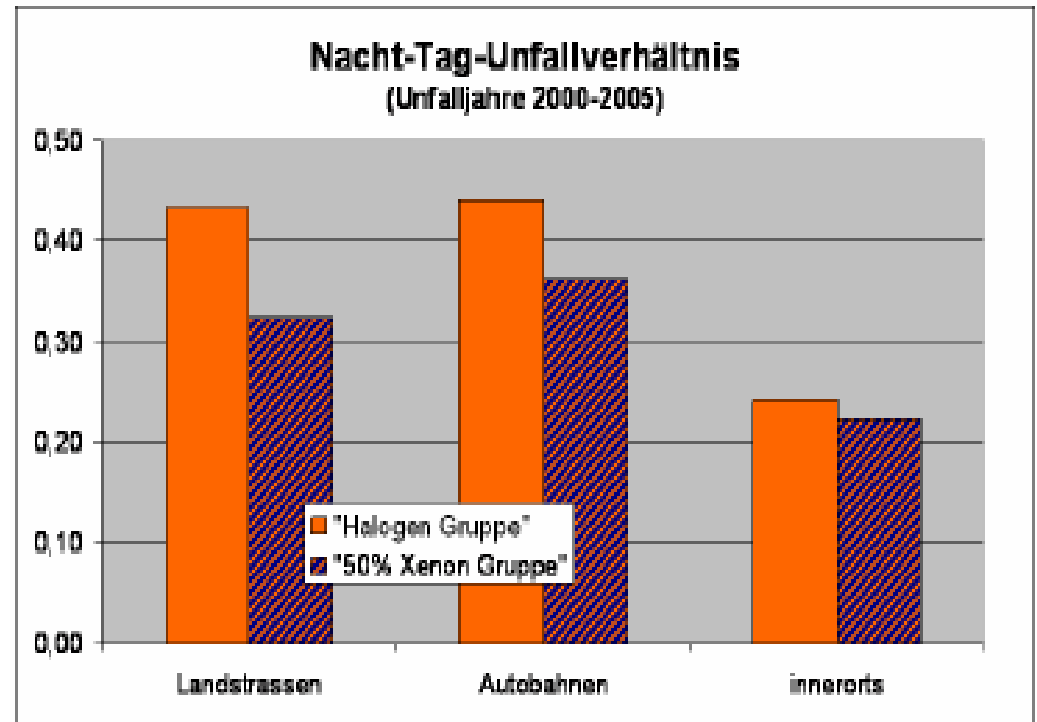

With the conclusion: Headlamps with improved light distribution and better performance are also a clear improvement for road safety.

Schlager Walter, Philips Technologie; Geywitz-Senn Johannes, Automotive Lighting  
Xenon-Licht zur Reduzierung des Unfallrisikos bei Nacht.; Light.Sight.Safety Report

Hull Roy W.; Hemion Roger H.; Cadena David G.; Guidelines for Improving the Stability of Headlamp Aim; DOT/HS-800 739; U.S. Departement of Transportation NHTSA, Washington D.C. ; 1972

### Headlamp Load-levelling Devices

Numerous methods have been devised to provide automatic headlamp aim compensation for changes in vehicle loading; however, very few have ever been incorporated in production vehicles available to the public. More numerous designs have been developed and made available, for providing vehicle load-levelling. This latter concept accomplishes the effect of headlamp aim control but also provides improved vehicle handling characteristics. It is seldom, if ever, promoted or incorporated on vehicles primarily to improve headlamp aim.

With the trend toward higher intensities for vehicle headlamps to improve highway vision, it is essential that better headlamp aim be achieved and maintained. Automatic headlamp levelling would appear to be essential to this effort.

# Literature studies regarding glare and visibility on road traffic

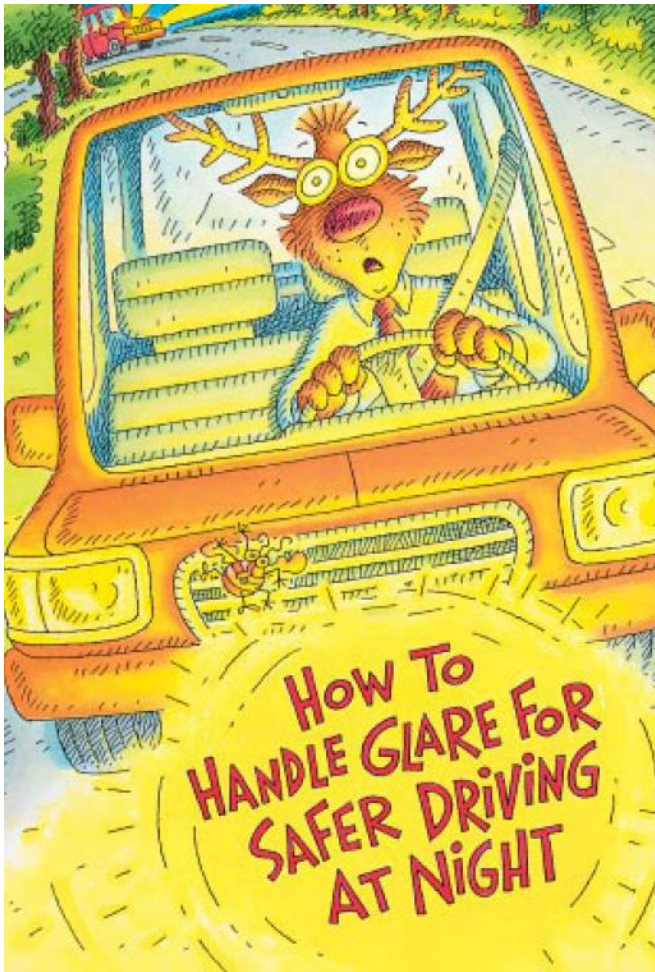

Thank you for your attention

Funded through the generosity of  and its members

AAA FOUNDATION FOR TRAFFIC SAFETY  
1440 New York Avenue, NW, Suite 201, Washington, DC 20005  
202-438-3844 • 800-953-7272 • www.aaafoundation.org  
Stock #70 ©2002  
Printed in USA

**GTB**

The International Automotive Lighting  
and Light Signalling Expert Group

Groupe de Travail "Bruxelles 1952"

GTB Document No. CE-5001

77

# Agenda

1. **GTB**

Introduction

2. **Poland**

Explanation of the background of the Polish proposal for R48

3. **GTB**

Literature Review

Night-time Field Test

Discussion

Comparison Klettwitz Outcome with Literature

Enrichment of Data by Calculation (CIE TC4-45)

4. **OICA**

Explanation of load conditions

5. **Joint GTB/Poland/OICA**

Conclusion

Suggestion

# GTB Field Test

**Dr. Rainer Neumann**  
**Chairman GTB WGFL**

**Geneva , 1.4.2014**

**GTB**

*The International Automotive Lighting  
and Light Signalling Expert Group*

*Groupe de Travail "Bruxelles 1952"*

GTB Document No. CE-5001

79

# Agenda

Introduction: Glare and Visibility

Klettwitz Field Test 2012

Discomfort Glare

Disability Glare

Special WGFL Meetings in Darmstadt (9/2013),  
Vienna (11/2013), and Torino (2/2014)

Summary



# Introduction

- Influencing Parameters for discomfort glare in Night Time Driving \* :
- - Initial aiming of the headlamps
- - geometry of the road
- - weather conditions
- - dynamic behaviour of vehicle

\* : GTB Lighting Forum Torino 1/2011

# Introduction

-  and loading condition of vehicles
- Report of statistical analysis of cars involved in accidents (France) :
- - **Accidental data : EACS + EDA**
  - ✓ **74% of cars involved in an accident have an empty trunk**
  - ✓ **21% of cars involved in an accident contain 0 - 40kg in the trunk**
  - ✓ **4% of cars involved in an accident contain 40 - 100kg in the trunk**
  - ✓ **0,5% of cars contain 100 - 190kg in the trunk**

# Questionnaire - de Boer Scale

Discomfort Glare Rating – (Please perform rating from top to bottom)

	Unnoticeable	Satisfactory	Just Admissible	Disturbing	Unbearable				
1	9	8 ✗	7	6	5	4	3	2	1
2	9	8	7 ✗	6	5	4	3	2	1
3	9	8	7	6	5 ✗	4	3	2	1
4	9	8	7	6	5	4	3	2 ✗	1
5	9	8	7	6 ✗	5	4	3	2	1

	Unnoticeable	Satisfactory	Just Admissible	Disturbing	Unbearable				
6	9	8	7	6 ✗	5	4	3	2	1
7	9	8	7	6	5	4	3 ✗	2	1

# Results for Halogen, Xenon, LED

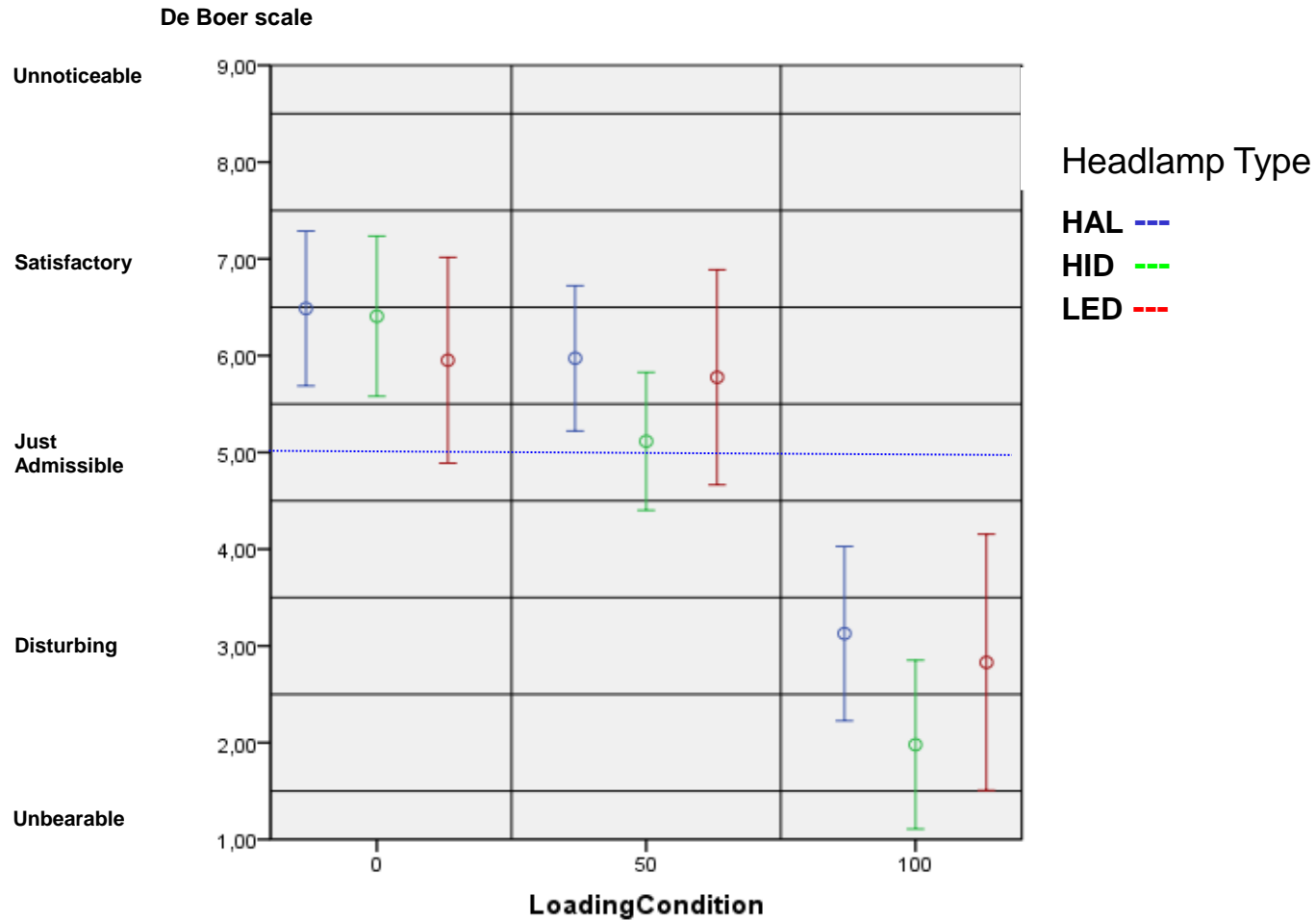

\* Width of the bars covers app. 70% of all ratings

# Results for all Light Sources

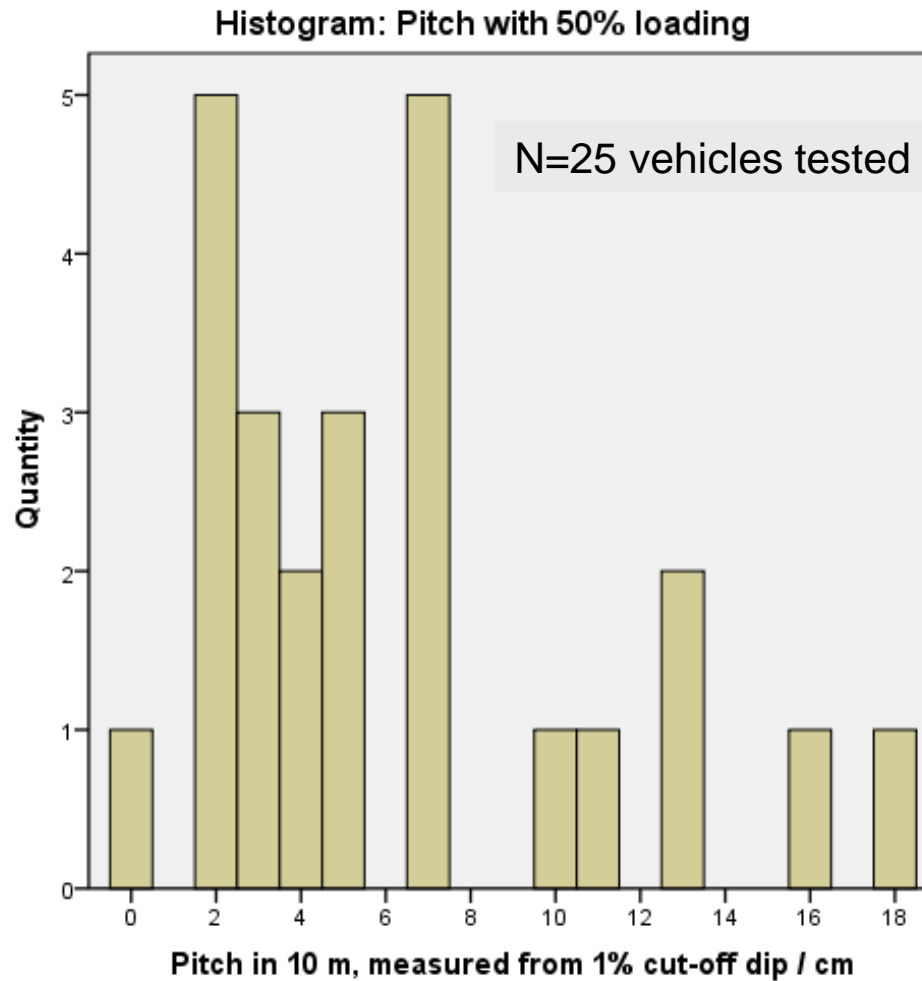

# Pitch Angle Results

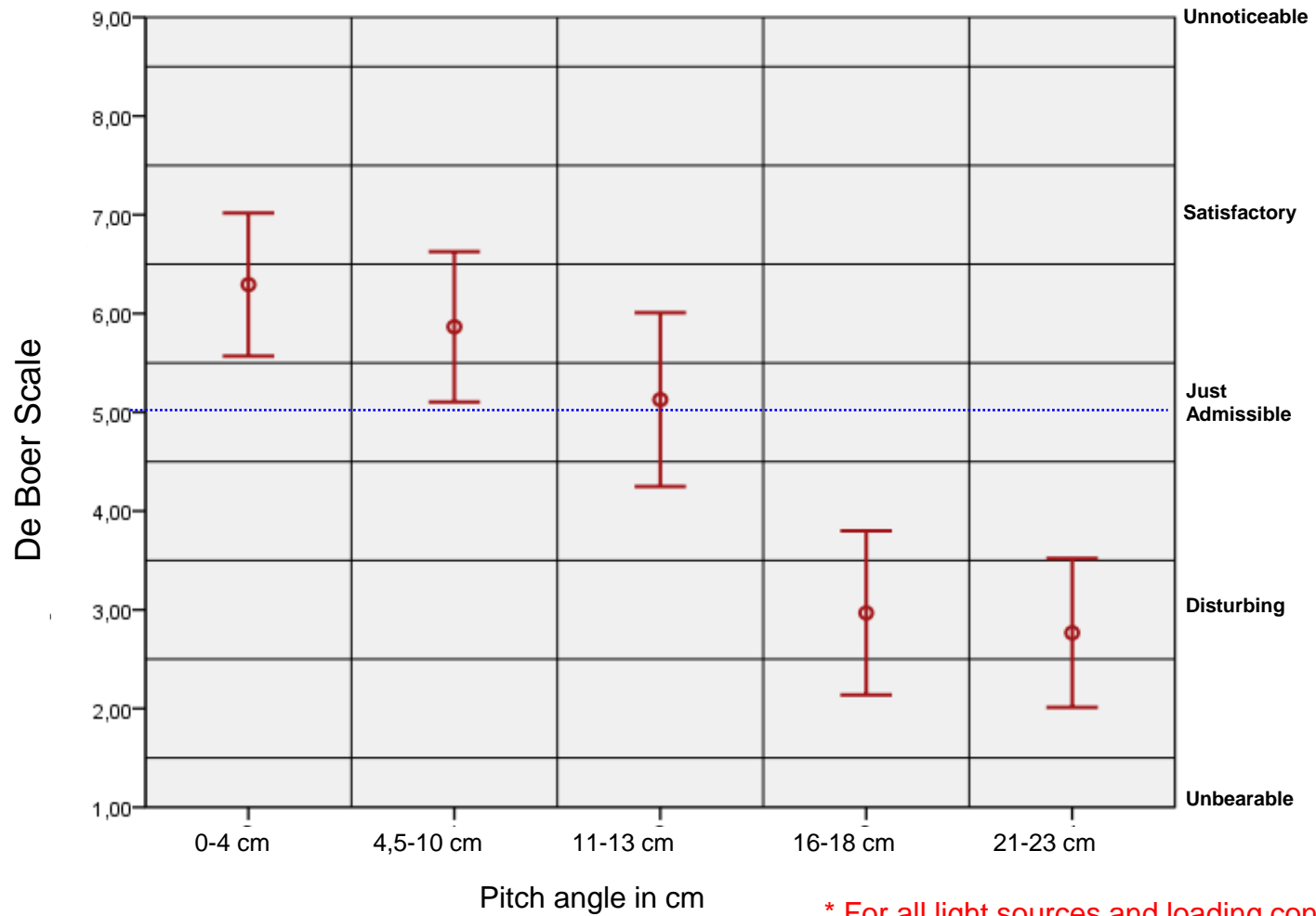

# Disability Glare

- Findings from Discomfort Glare based on de Boer rating have been verified by studying the results on luminance and illuminance values of the tested vehicles

# Measured Quantities

- Luminance  $L_v$ 
  - $L_v$  @ 25 m and 50 m, driver position
- Illuminance  $E_v$ 
  - $E_v(t)$ , driver- and co-driver position

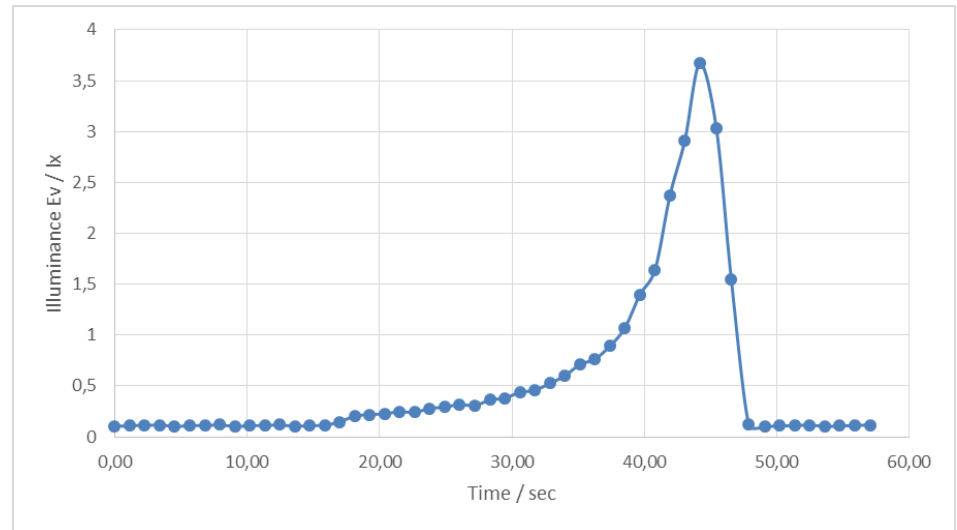



# Luminance

- Total luminance
  - Lv\_mean, Lv\_max

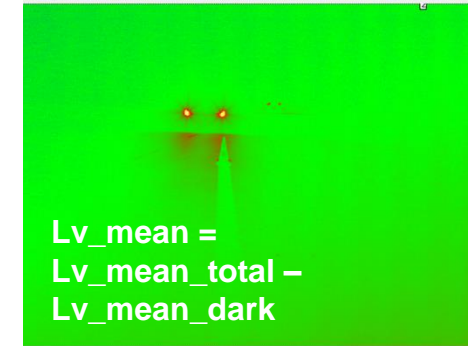
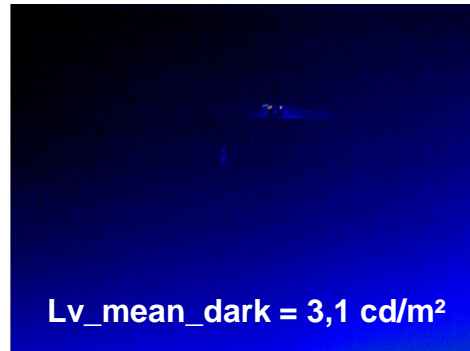

- Area with Lv > 310 cd/m<sup>2</sup>, adaptation was 3,1 cd/m<sup>2</sup>:
  - In this area: Lv\_mean, Lv\_max, Size

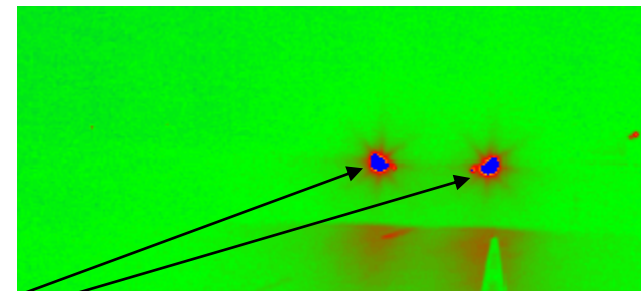
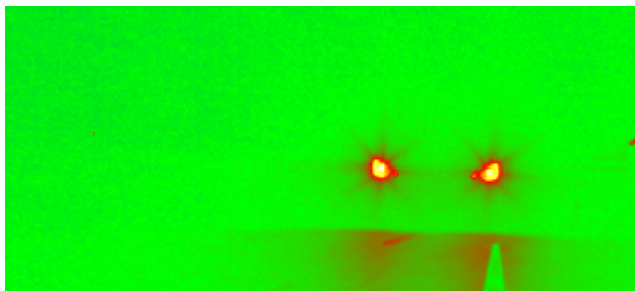

Stat.Nr.	Parameter	Bild	Region	Klasse	Fläche	Min	Max	Mittelwert	Streuung
1	Lum Gr[1]	Leuchtdichtebild	2	Hell	402	326,6	41000	5121	7509

# Luminance VS Loading Condition

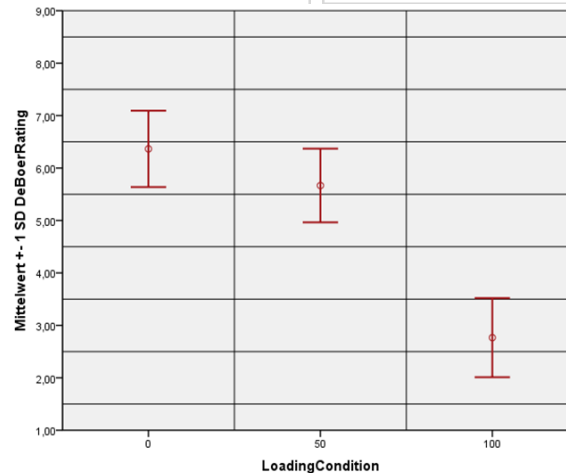
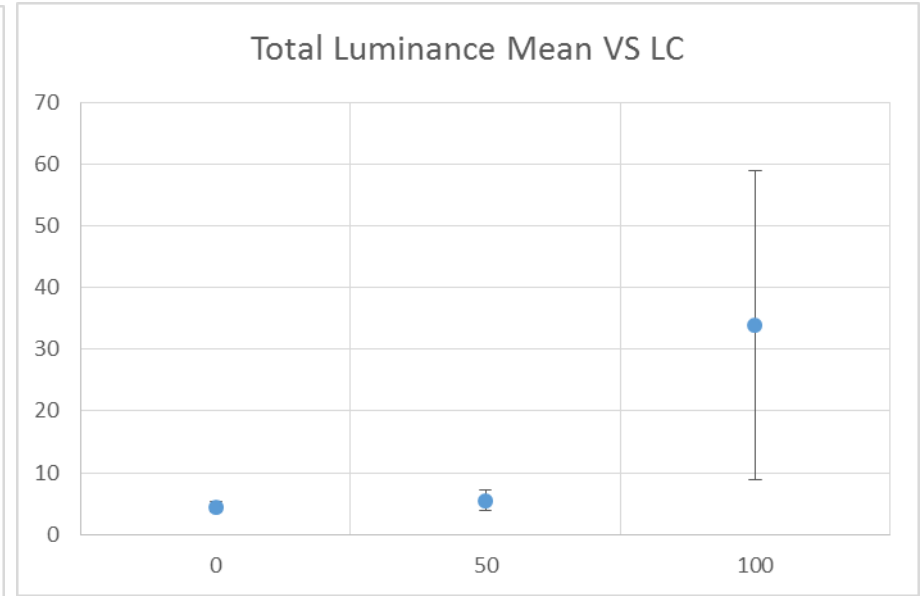
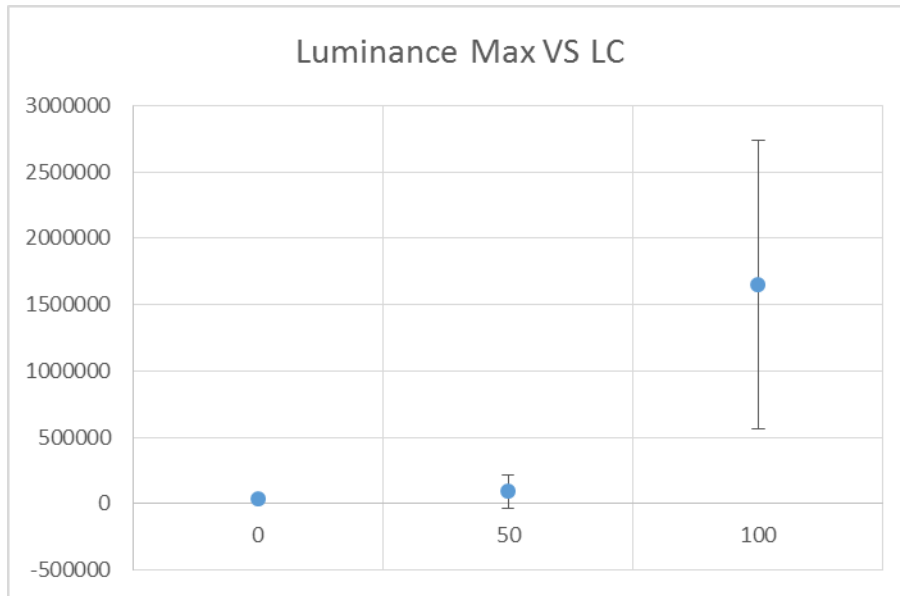

# Evaluation of Illuminance

- Maximum of illuminance  $E_{v\_max}$
- Exposure in 400 m (Sprute): 80 km/h → 18 sec exposure time

$$H_v = \int_0^{18} E_v(t) dt$$

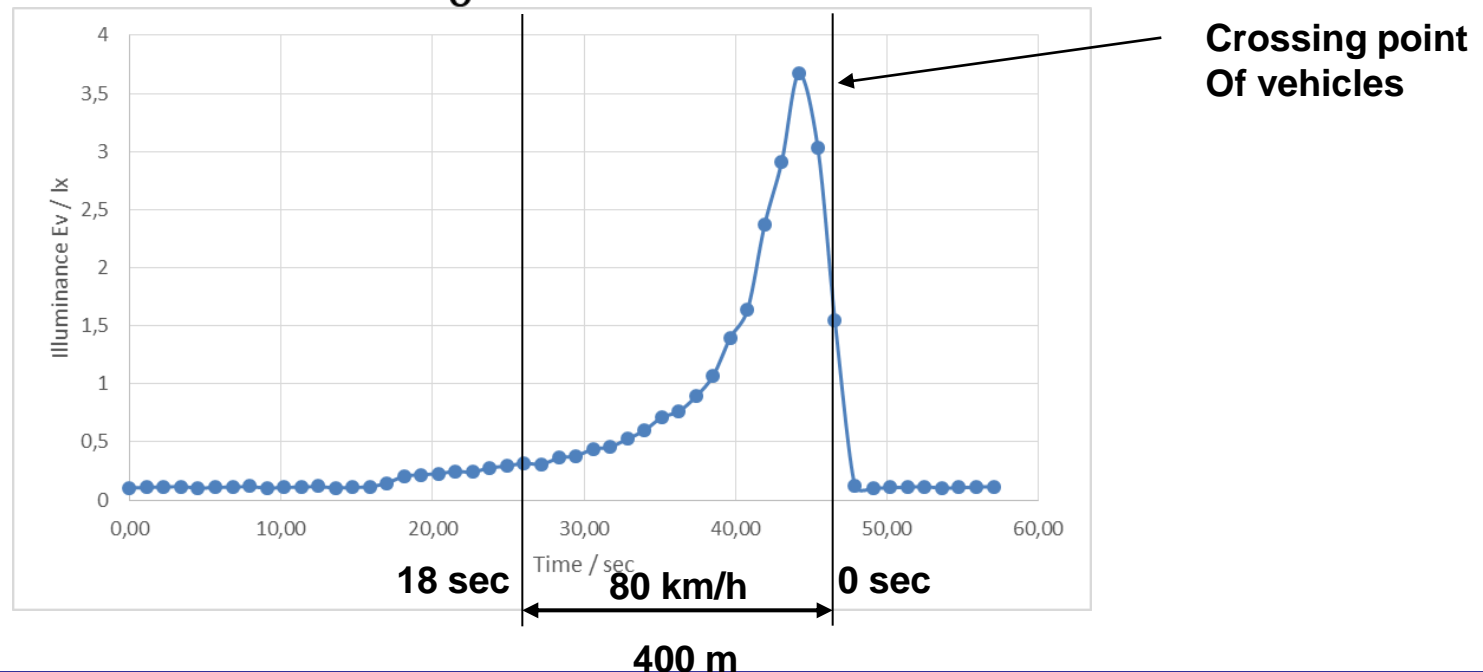

# Illuminance VS Loading Condition

Max Illuminance VS LC

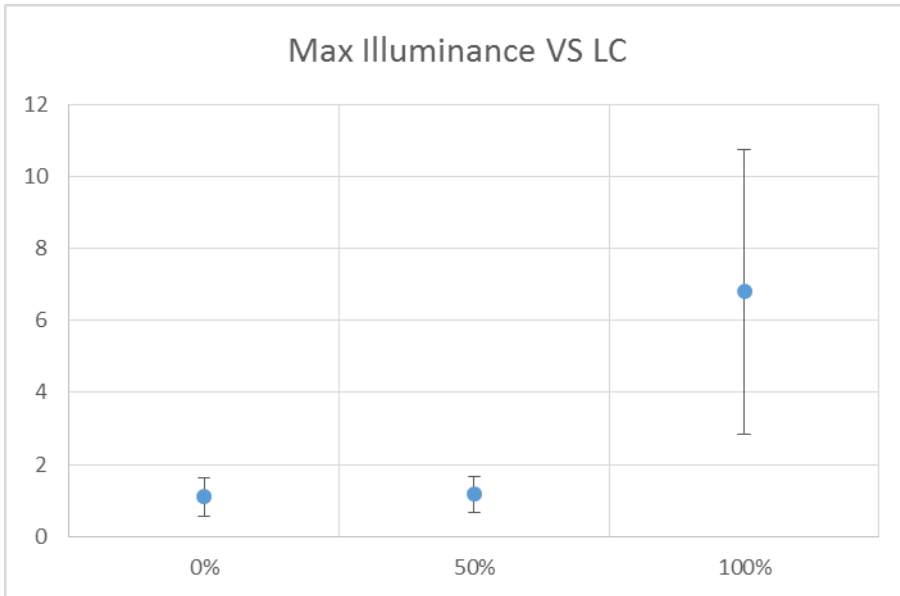

Exposure VS LC

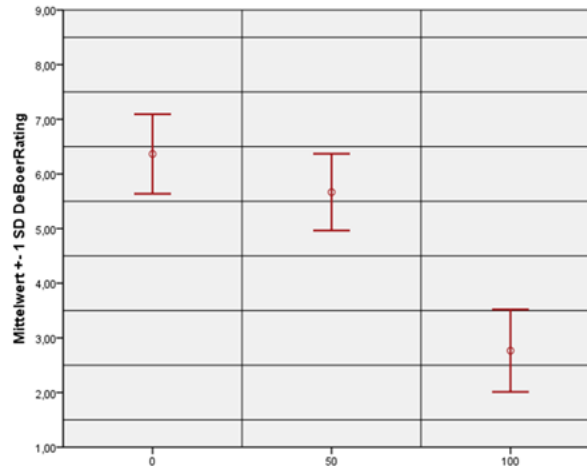
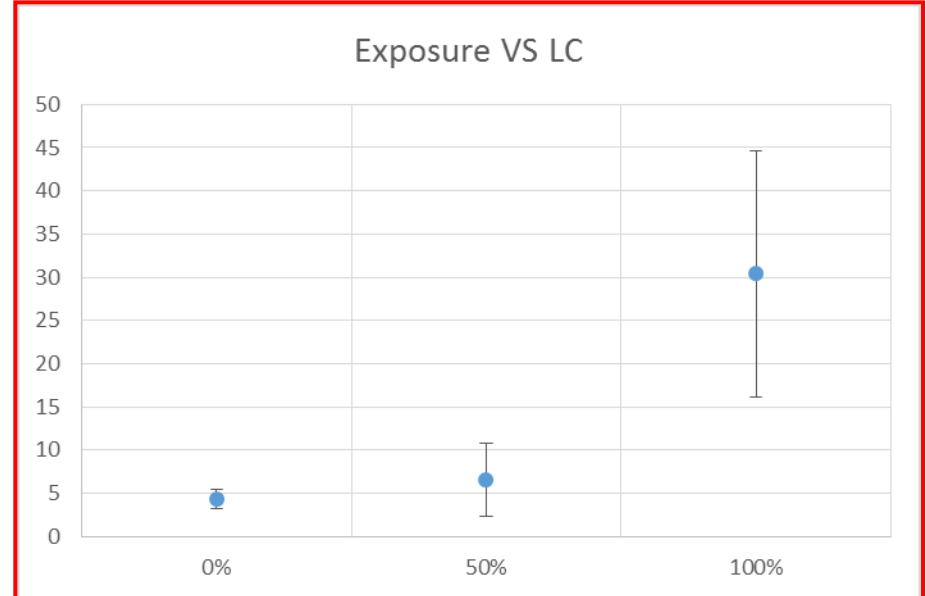

# Summary

- Results of Discomfort Glare and disability glare show clearly, that the behaviour of the vehicle is the important factor for deciding on levelling needs
- Light source is not significantly contributing
- Pitch angle is a qualified parameter for new regulation criteria

# Summary

- The results show clearly, that the pitch angle as a parameter to measure the reaction of the vehicle according to loading could lead to a definition, where levelling is required and where it is not needed
- Car makers have to analyze, how a prediction of the pitch angle of a car under development could be determined

# Action

- Special meeting in WGFL was organized in Darmstadt in 9/2013
- Continued discussion in GTB meeting (11/2013) in Vienna and GTB Intermediate Meeting WGFL in Torino (2/2014)

# Summary

- Input from various car makers to a prediction of the behaviour of future vehicles
- Discussion on a method to generate a classification with pitch angle to forecast the sensitivity of loading of newly developed vehicles
- Some car makers presented loading results on pitch angles of existing vehicles
- Statements from car makers have been collected



# Summary

- Contributions from car makers show positive signals in being able to predict pitch angle of a vehicle in advance

# Acknowledgements

- Thanks to TU Darmstadt Prof. Khanh, Dipl.-Ing. Bastian Zydek
- Thanks to DEKRA
- Thanks to GTB / GRE participants
- Thanks to car makers

Project within GTB TF CAVGS

# Agenda

1. **GTB**

Introduction

2. **Poland**

Explanation of the background of the Polish proposal for R48

3. **GTB**

Literature Review

Night-time Field Test

Discussion

Comparison Klettwitz Outcome with Literature

Enrichment of Data by Calculation (CIE TC4-45)

4. **OICA**

Explanation of load conditions

5. **Joint GTB/Poland/OICA**

Conclusion

Suggestion

# Intermediate Summary

- Night Test Measurement Conditions
  - 50% load
  - 1 % aiming
  
- Visibility and Glare
  - GTB conducted a test drive focused on glare
  - Poland presented a proposal focused on visibility distance
  
- Correlation Night Test Experimental findings with Literature?

# Agenda

1. **GTB**

Introduction

2. **Poland**

Explanation of the background of the Polish proposal for R48

3. **GTB**

Literature Review

Night-time Field Test

Discussion

Comparison Klettwitz Outcome with Literature

Enrichment of Data by Calculation (CIE TC4-45)

4. **OICA**

Explanation of load conditions

5. **Joint GTB/Poland/OICA**

Conclusion

Suggestion

# Klettwitz Results in View of the Literature Study of WG SVP

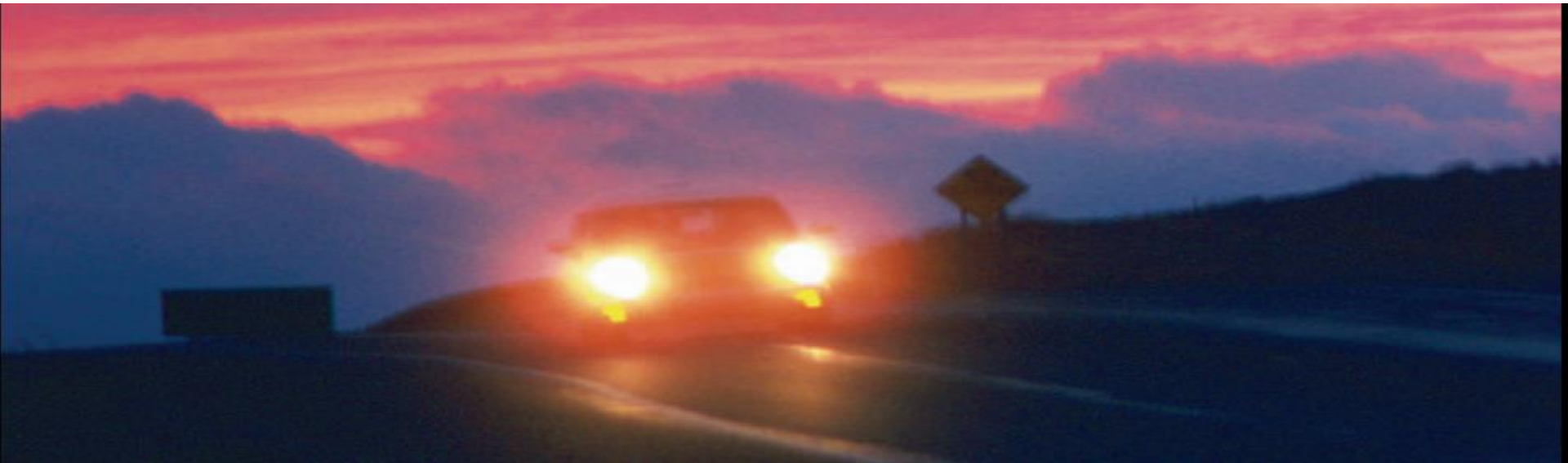

Karl Manz  
Chairman GTB WG SVP

Geneva, 01 April 2014

**GTB**

*The International Automotive Lighting  
and Light Signalling Expert Group*

*Groupe de Travail "Bruxelles 1952"*

GTB Document No. CE-5001

102

## Question 1:

How does the distribution of the pitch angles of the Klettwitz study and of a French investigation fit into the results from Hanno Westermann or rather into the estimation of E.-O. Rosenhahn?

## Histogram for pitch angle for 50% loading of the Klettwitz Study

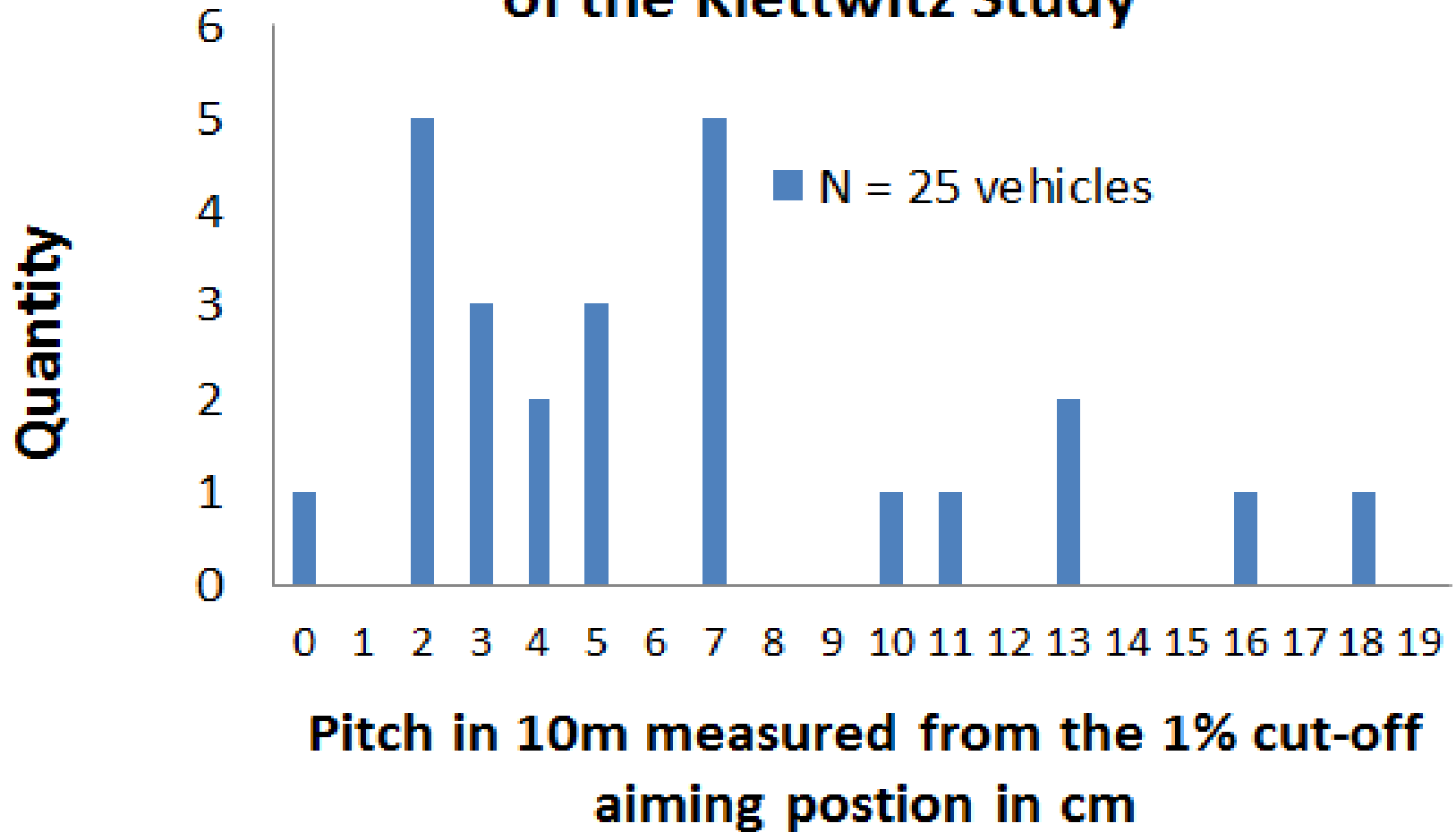



Data from Klettwitz Study

- 18
- 15
- 12
- 9
- 6
- 3
- 0

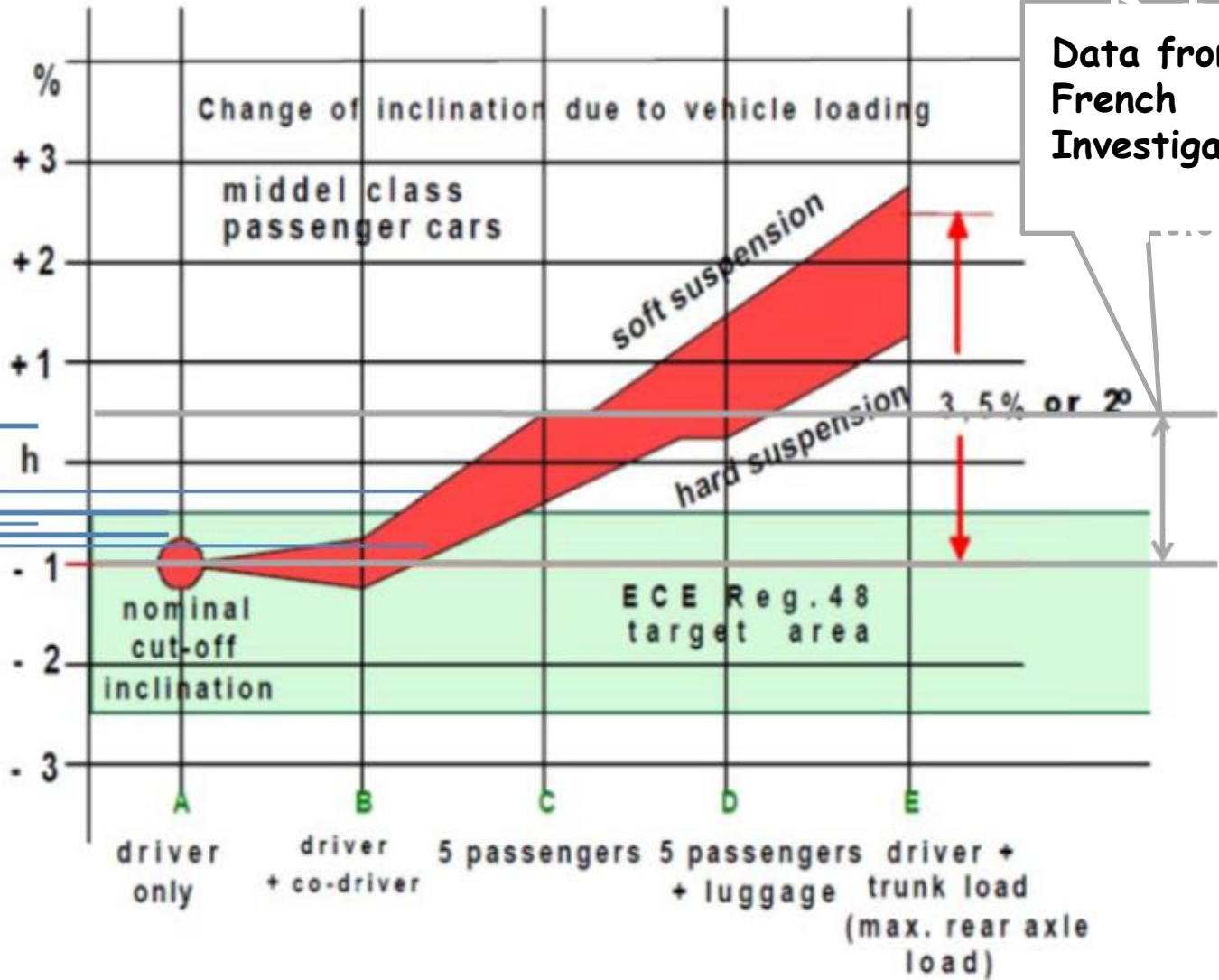

Data from a French Investigation

# Estimation of Pitch Angle Frequency Spectrum caused by Vehicle Load

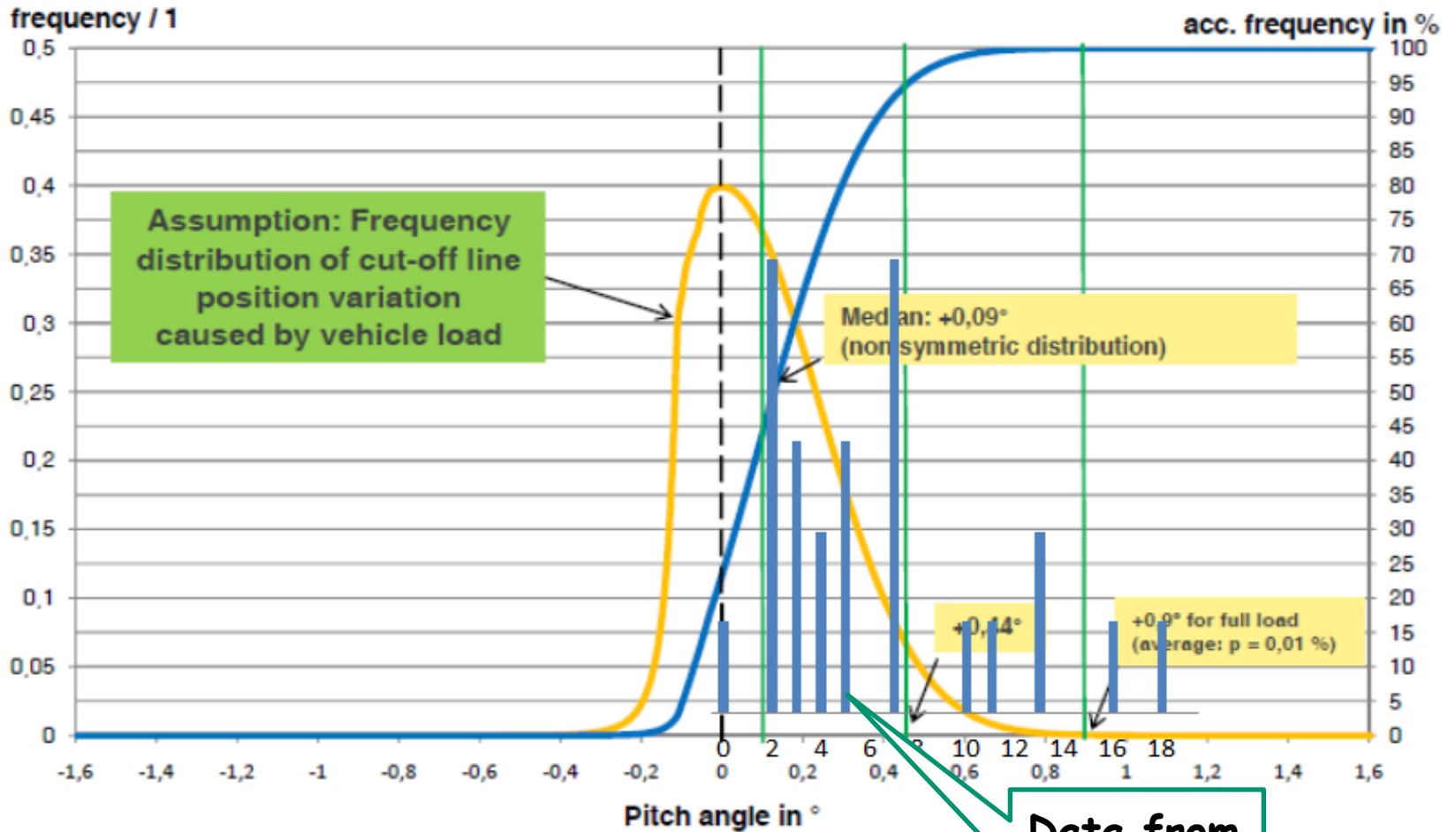

## Question 2:

Mr. Zydek from TUD has found a good correlation between glare and exposure. How does this fit into the literature findings?

# Evaluation of Illuminance

- Maximum of illuminance  $E_{v\_max}$
- Exposure in 400 m (Sprute): 80 km/h → 18 sec exposure time

$$H_v = \int_0^{18} E_v(t) dt$$

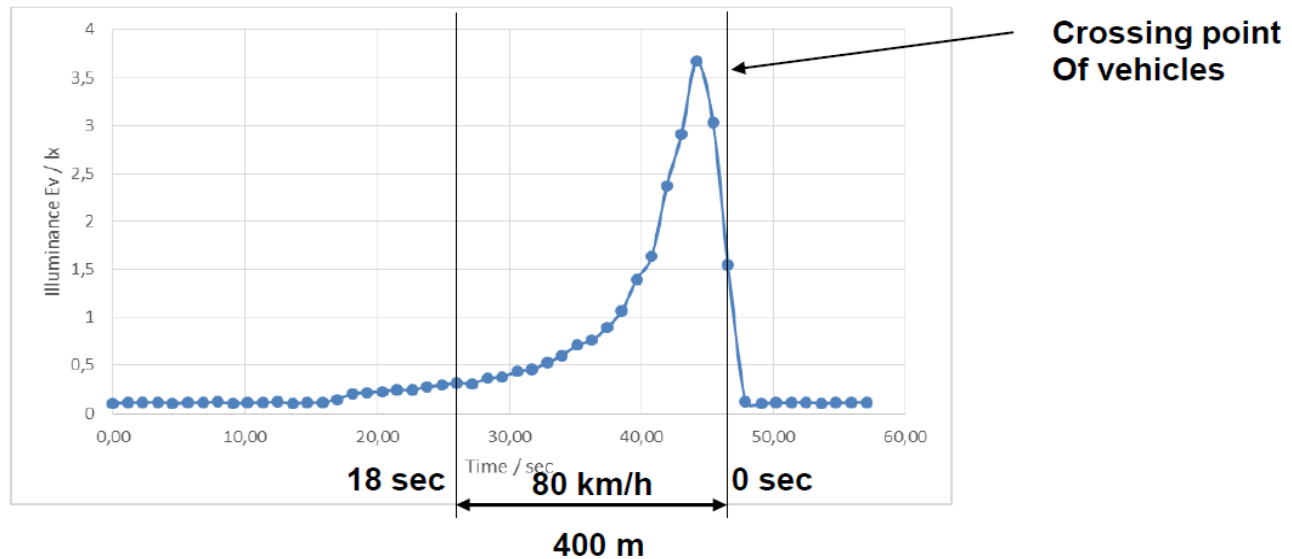

# Glare Illuminance as a Function of the Distance Between Oncoming Vehicles

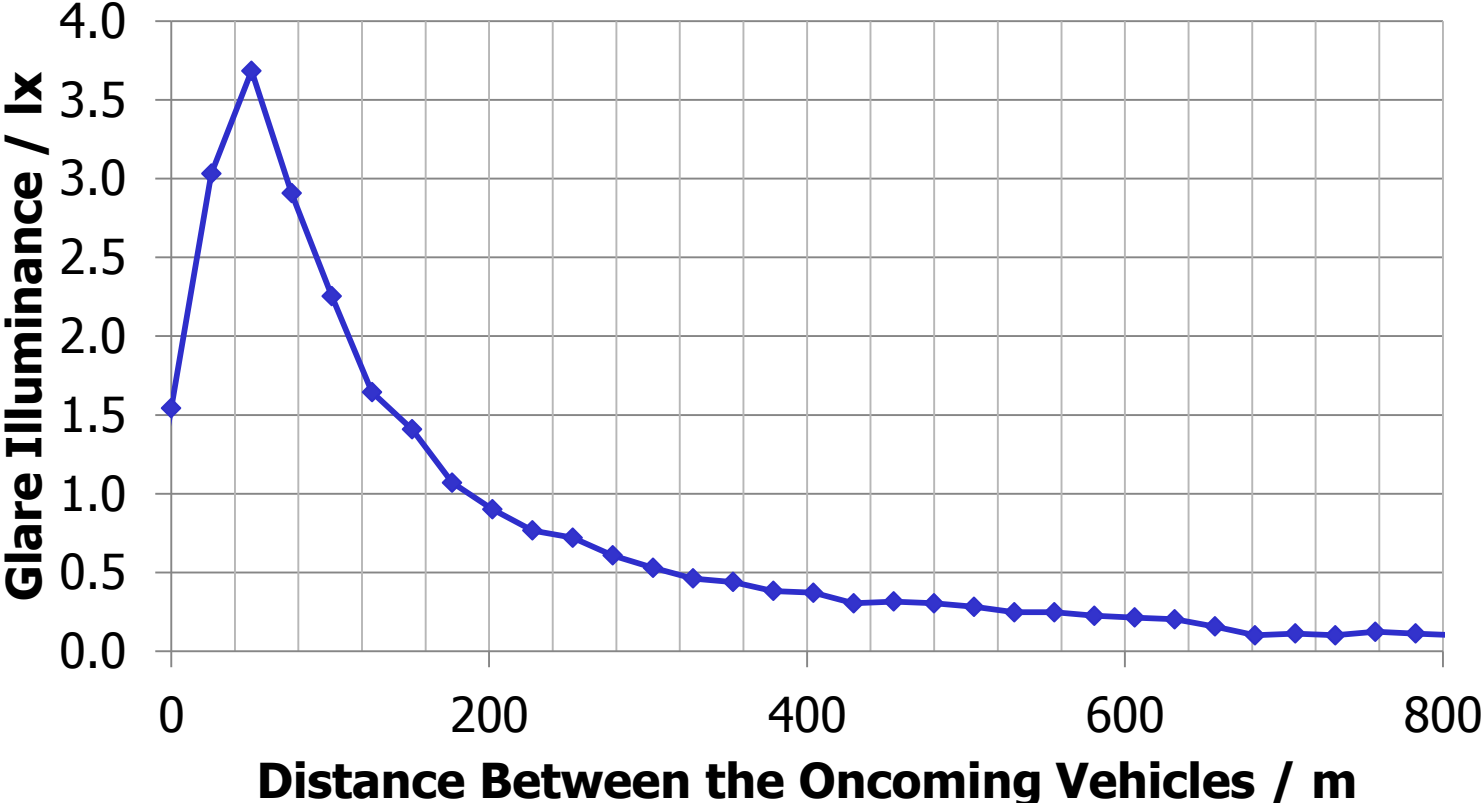

# Visibility Distance and Glare Illuminance as a Function of the Distance Between Oncoming Vehicles

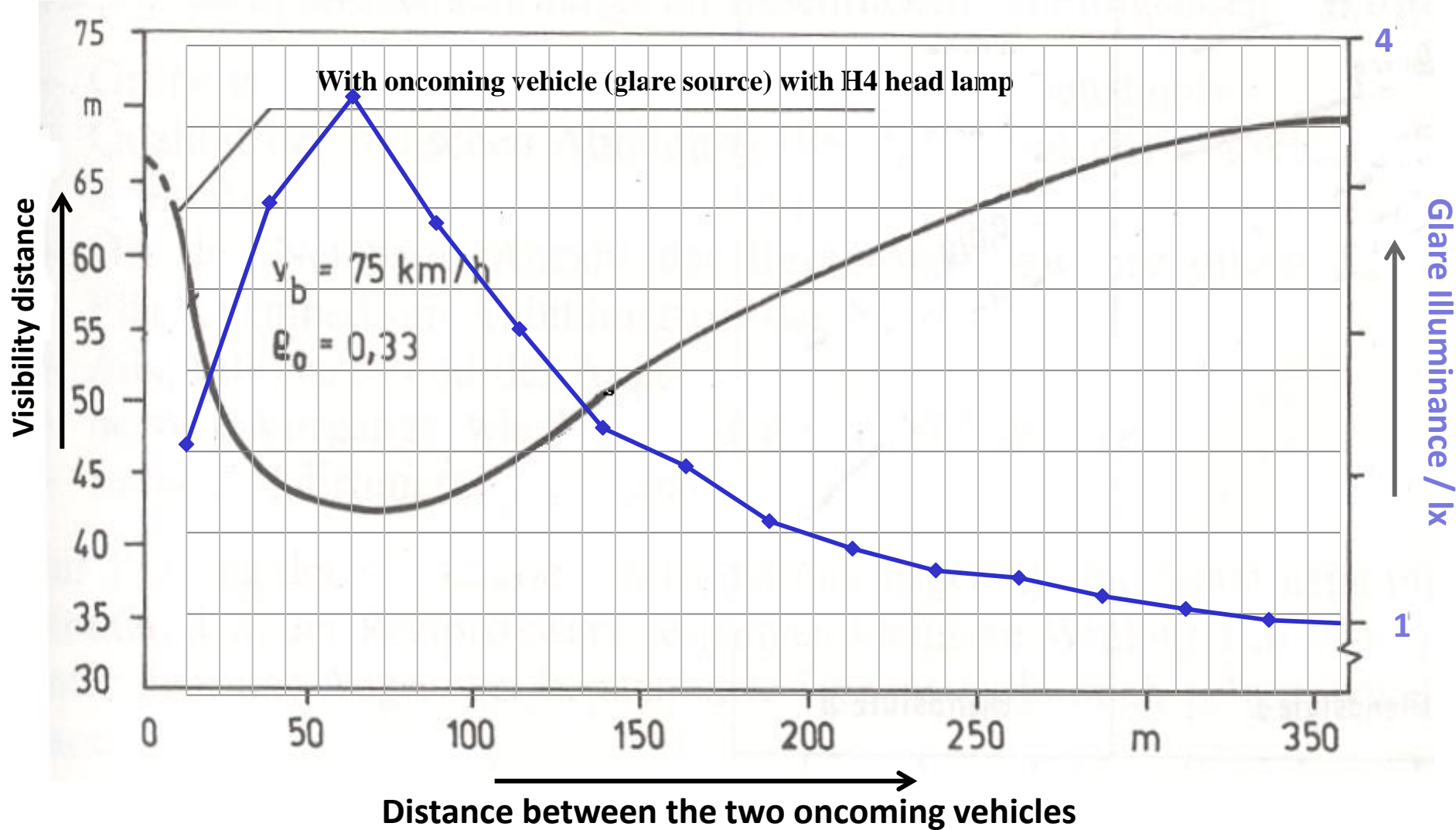

## Question 3:

How do the results of the glare ratings, over all headlamp technologies used in the Klettwitz study, as a function of the pitch angles of the Klettwitz study fit e. g. to the results from Pedestrian Visibility investigation?

# Pitch Angle Results

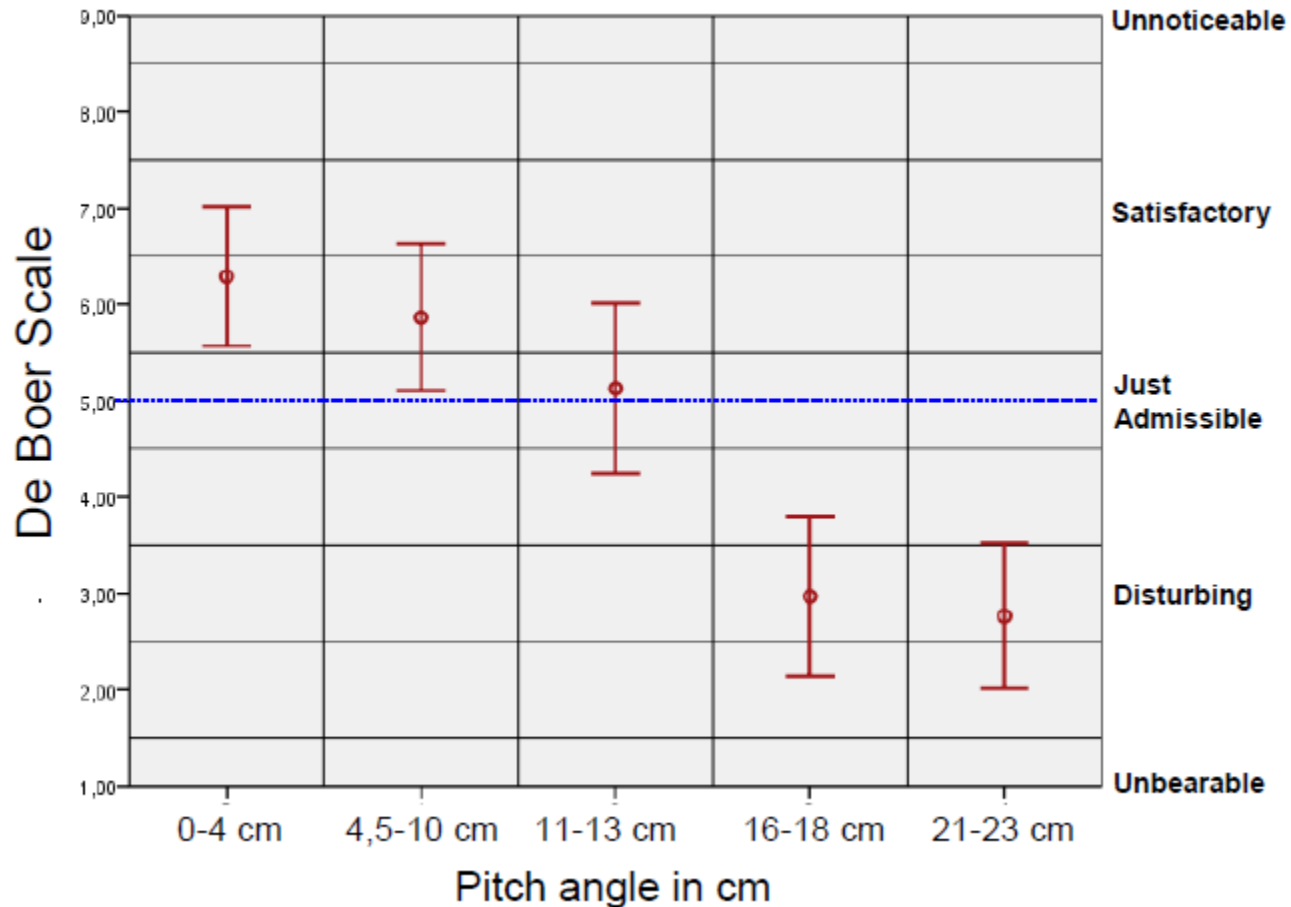

\* For all light sources and loading conditions



The bright red values with the error bars are the Klettwitz results;

The lines show the results from a H4 headlamp, used in TC 4/45, for different mounting heights as a function of the pitch angle. To transform the values from TC 4/45 glare criteria to the de Boer scale, the 1-lumen threshold of TC 4/45 was set to the de Boer rating 5 (just admissible).

## Weighted Flux in Glare Zone Related to Headlamp Mounting Height

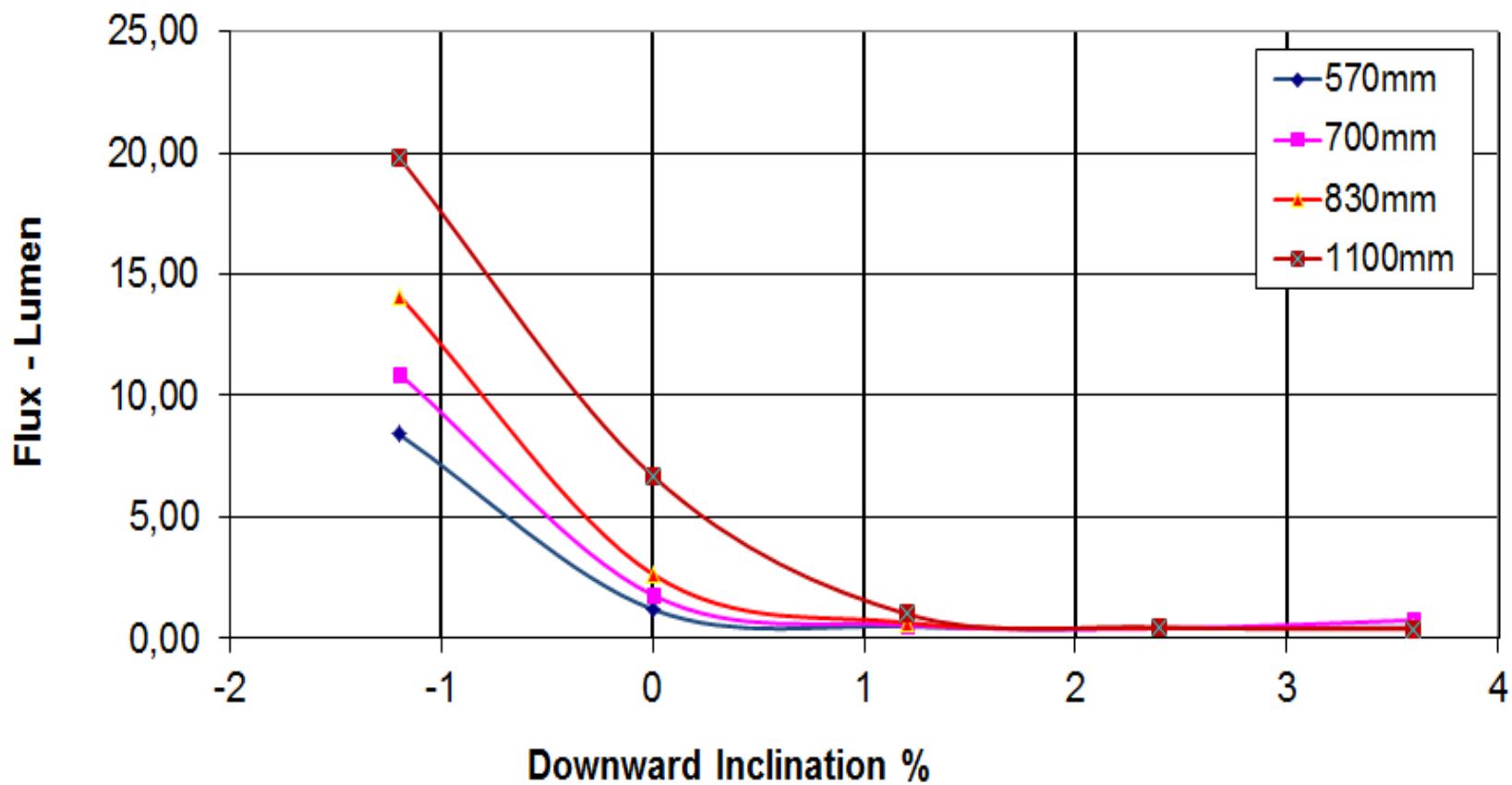

# Comparison of Results from Klettwitz and Pedestrian Study

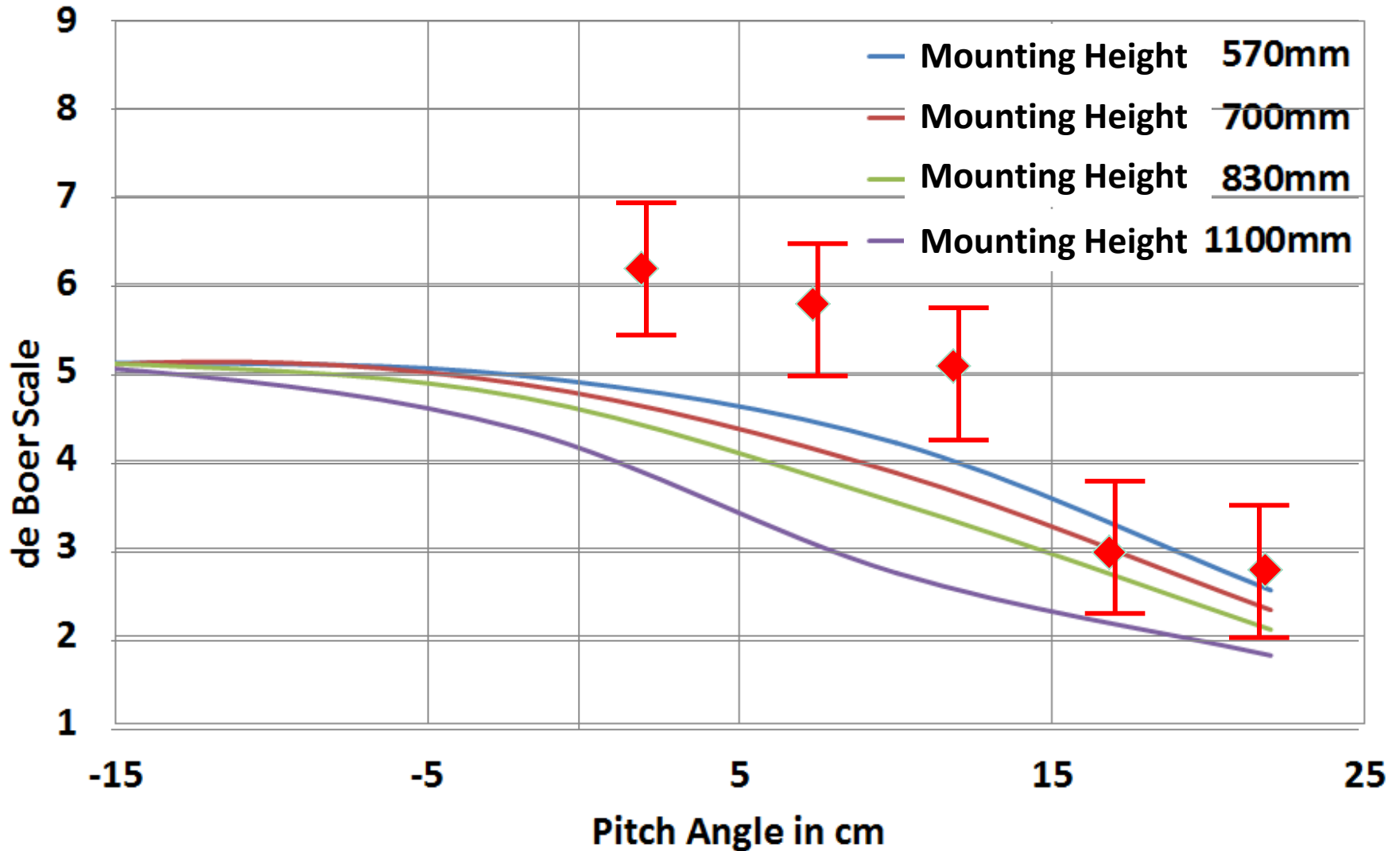

# Thank you for your attention



Funded through the generosity of  and its members

**AAA FOUNDATION FOR TRAFFIC SAFETY**  
1440 New York Avenue, NW, Suite 201, Washington, DC 20005  
202-638-5844 • 800-993-7222 • [www.aaaoundation.org](http://www.aaaoundation.org)

STOCK #10  
©2002  
Printed in USA

**GTB**

The International Automotive Lighting  
and Light Signalling Expert Group

Groupe de Travail "Bruxelles 1952"

GTB Document No. CE-5001

116

# Agenda

1. **GTB**

Introduction

2. **Poland**

Explanation of the background of the Polish proposal for R48

3. **GTB**

Literature Review

Night-time Field Test

Discussion

Comparison Klettwitz Outcome with Literature

Enrichment of Data by Calculation (CIE TC4-45)

4. **OICA**

Explanation of load conditions

5. **Joint GTB/Poland/OICA**

Conclusion

Suggestion

# Headlamp Glare and Range – Enrichment of Data by Calculations

Gert Langhammer  
Chairman CIE TC4-45

Geneva, 01 April 2014

---

## Headlamp Glare and Range – Enrichment of data by calculation

---

### Agenda

- The role of passing beam cutoff
- CIE TC4-45 - objective method of assessing headlamp glare and range
  - History of CIE TC4-45
  - Headlamp glare and range in TC4-45
- Headlamp glare and range under different conditions – collection of data as result of TC4-45 calculations
- Calculation results in relation to Klettwitz field test outcome

## The passing beam cutoff

---

**The role of the passing beam** is to **provide good illumination** of the road scene **without causing unacceptable glare to oncoming drivers**. This is achieved by a combination of the control of the performance of the passing beam by means of the provisions in the applicable headlamp regulation and the correct installation according to Regulation 48.

The requirements in the installation regulation would ideally be performance based but as these are fundamentally photometric requirements it is not possible to carry out objective performance testing on a complete vehicle. This means that the **control of the headlamp performance must be achieved through the application of the requirements in the headlamp regulations** and the **“on-road” performance must be assured by correct installation** according to the provisions relating to the initial aim and the maintenance of aim in Regulation 48.



# CIE TC4-45

Performance Assessment Method  
for Vehicle Headlamps

## The passing beam cutoff

The Passing Beam Cutoff is the visible line perceived by the eye when the beam pattern is projected onto a vertical screen.

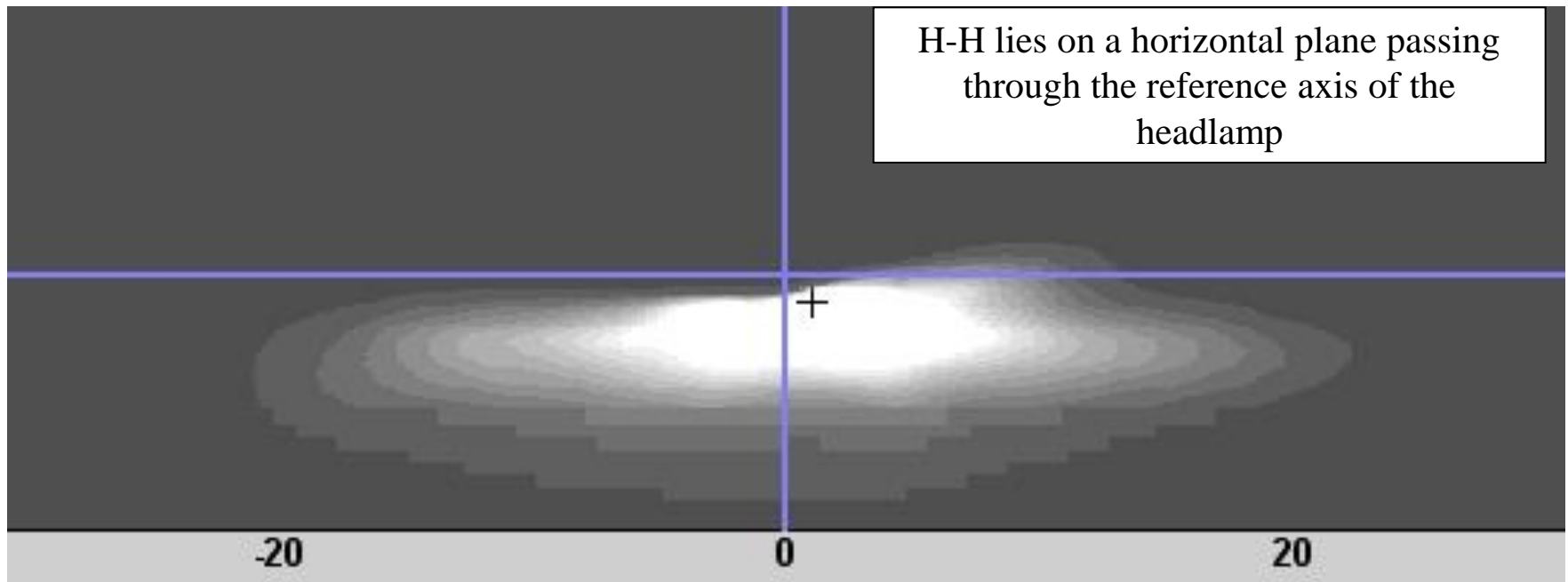

Normally the beam pattern is viewed at a distance of 25m for visual aiming prior to photometry but a viewing distance of 10m is also allowed for practical reasons

## The passing beam cutoff

---

The clarity of the cutoff line varies from diffuse to sharp. Sharpness is defined in the headlamp regulations to ensure that the beam can be visually aimed by means of the cutoff but equally the cutoff is not too sharp as this contributes to glare complaints and driver fatigue.

*E/ECE/324/Rev.2/Add.111/Rev.2*  
*E/ECE/TRANS/505/Rev.2/Add.111/Rev.2*  
*Annex 9*

### 2.2. Sharpness of “cut-off”

The sharpness factor  $G$  is determined by scanning vertically through the horizontal part of the “cut-off” at  $2.5^\circ$  from the V-V where:

$G = (\log E_\beta - \log E_{(\beta + 0.1^\circ)})$  where  $\beta$  = the vertical position in degrees.

The value of  $G$  shall not be less than 0.13 (minimum sharpness) and not greater than 0.40 (maximum sharpness).

There is no significant relationship between the cutoff sharpness and the performance of the headlamp on the road. A headlamp that just meets the minimum requirements of the regulation may have a sharper cutoff than a headlamp that exceeds the minimum requirements by a factor of several times.

# CIE TC4-45

## Performance Assessment Method for Vehicle Headlamps

### Two passing beam patterns compared – the passing beam cutoff

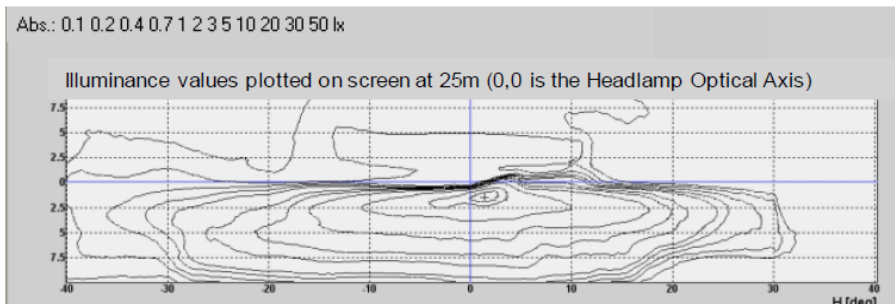

Halogen Headlamp with horizontal cutoff aimed 1% down



Range based upon assumption that the horizontal (left side) cutoff line will intersect the road surface at  $D = H/1\%$   
(D = Range; H = mounting height)

Mounting Height = 0.63m  
Assumed Range = 63m

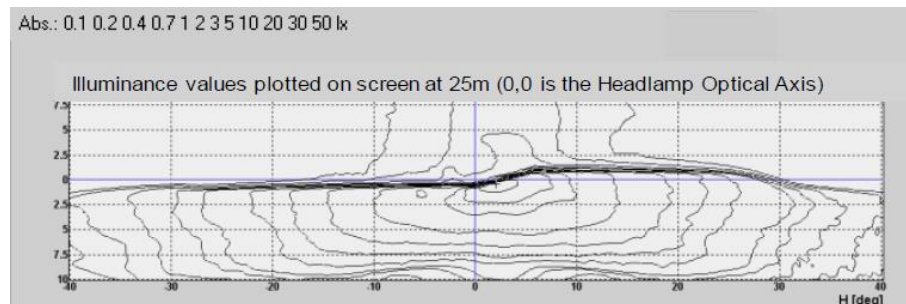

HID Headlamp with horizontal cutoff aimed 1% down



Range based upon assumption that the horizontal (left side) cutoff line will intersect the road surface at  $D = H/1\%$   
(D = Range; H = mounting height)

Mounting Height = 0.72m  
Assumed Range = 72m

# CIE TC4-45

## Performance Assessment Method for Vehicle Headlamps

### Two passing beam patterns compared – Range according to TC4-45

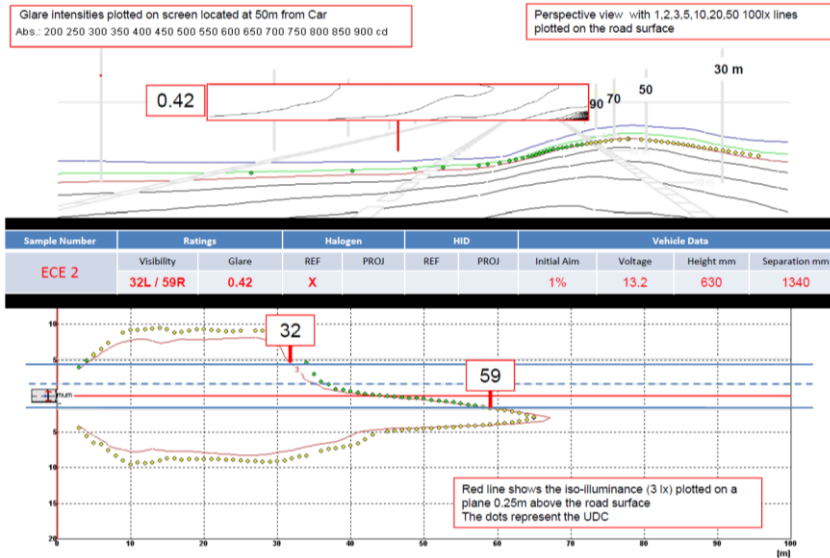

Range based upon CIE TC4-45 Criteria = 32m Left /  
59 m Right

Mounting Height = 0.63m

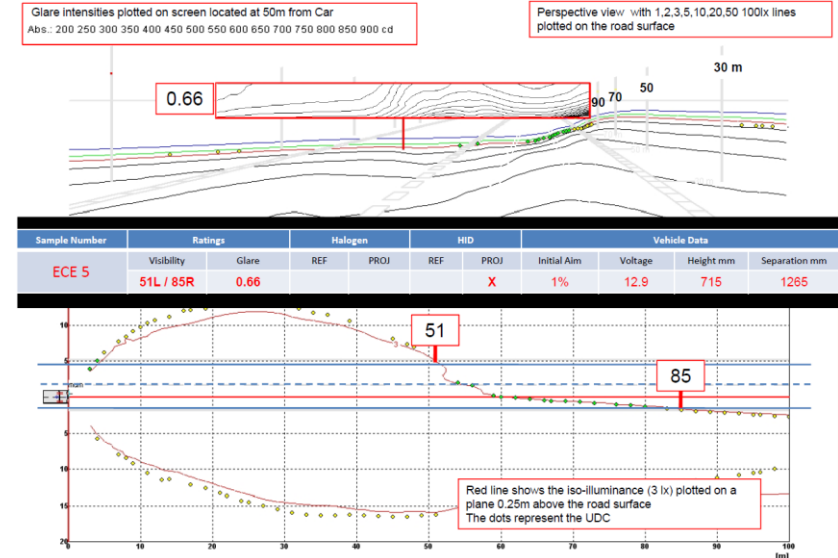

Range based upon CIE TC4-45 Criteria = 51m Left /  
85 m Right

Mounting Height = 0.72m

# CIE TC4-45

## Performance Assessment Method for Vehicle Headlamps

### Conclusion

Halogen Headlamp with horizontal cutoff aimed 1% Down

Range based upon CIE TC4-45 Criteria  
= 32m Left / 59 m Right  
Mounting Height = 0.63m

Range based upon assumption that the horizontal (left side) cutoff line will intersect the road surface at  $D = H/1\%$   
(D = Range; H = mounting height)

Mounting Height = 0.63m  
Assumed Range = 63m

	Discrepancy	
	Left Side	Right Side
Actual (Calculated)	32m	59m
Assumed	63m	**

HID Headlamp with horizontal cutoff aimed 1% Down

Range based upon CIE TC4-45 Criteria  
= 51m Left / 85 m Right Mounting  
Height = 0.72m

Range based upon assumption that the horizontal (left side) cutoff line will intersect the road surface at  $D = H/1\%$   
(D = Range; H = mounting height)

Mounting Height = 0.72m  
Assumed Range = 72m

	Discrepancy	
	Left Side	Right Side
Actual (Calculated)	51m	85m
Assumed	72m	**

\*\* The assumption of the range is based upon the position of the horizontal part of the cutoff so it does not apply to the Right Side figures

# CIE TC4-45

Performance Assessment Method  
for Vehicle Headlamps

---

## TC4-45 - objective method of assessing headlamp glare and range

---

### History of CIE TC4-45

# CIE TC4-45

Performance Assessment Method  
for Vehicle Headlamps

---

## **TC4-45 - objective method of assessing headlamp glare and range**

---

In 2003 GTB and NCAP created a taskforce with the aim of developing a headlamp performance rating system to be proposed to the European New Car Assessment Programme (Euro NCAP).

After Euro NCAP decision in 2005 not to continue to introduce a headlight rating system the work of this taskforce was transferred into CIE structure.

CIE Technical Committee 4-45, working in conjunction with GTB, continued to work on the refinement of the assessment of headlamp range and glare.

# CIE TC4-45

Performance Assessment Method  
for Vehicle Headlamps

---

## **TC4-45 - objective method of assessing headlamp glare and range**

---

Experts from 52 manufacturers, institutions and test services worldwide were taking part in the development of an objective method of assessing vehicle front lighting. The aim was to create a method which is based just on photometric measurements and calculations.

In 2010 the work of TC4-45 was finalized with the publication of a CIE Technical Report (CIE188: 2010).

In 2011 CIE released the new standard:

CIE S021/E:2011  
Vehicle Headlighting Systems  
Photometric Performance – Method of Assessment



# CIE TC4-45

Performance Assessment Method  
for Vehicle Headlamps

---

**Standard CIE S021/E:2011**

**Technical Report CIE 188:2010**

---



---

**PRESS RELEASE**

May 2011

---

**New Standard CIE S 021/E:2011**

## **Vehicle Headlighting Systems Photometric Performance - Method of Assessment**

This Standard specifies a method to consistently assess the photometric performance of vehicle headlighting systems to enable the performance of different systems to be compared. The requirements are given in relation to road scene illumination and the limitation of glare, and the performance is assessed using parameters relevant to lane guidance and the detection of pedestrians and objects.

The Standard includes a measurement and calculation procedure. It does not specify the format of an assessment report.

The Standard is written in English and has been approved by CIE National Committees. It is readily available at the National Committees of the CIE or via the website of the Central Bureau of the CIE ([www.cie.co.at](http://www.cie.co.at)).

The price of this Standard is EUR 135,- (Members of the National Committees of the CIE get 66,7% discount).



ISBN 978 3 901906 84 8

COMMISSION INTERNATIONALE DE L'ECLAIRAGE  
INTERNATIONAL COMMISSION ON ILLUMINATION  
INTERNATIONALE BELEUCHTUNGSKOMMISSION

# **TECHNICAL REPORT**

## **PERFORMANCE ASSESSMENT METHOD FOR VEHICLE HEADLIGHTING SYSTEMS**

CIE 188:2010

UDC: 628.971.85  
628.971.85:629.113.06

Descriptor: Lighting by lamps attached to the vehicle  
Lighting by motor vehicle lamps

---

**GTB**

The International Automotive Lighting  
and Light Signalling Expert Group

Groupe de Travail "Bruxelles 1952"

GTB Document No. CE-5001

129

# CIE TC4-45

Performance Assessment Method  
for Vehicle Headlamps

## Headlamp Glare and Range in TC4-45 – input parameters

The system Headlamps + Car is evaluated ...

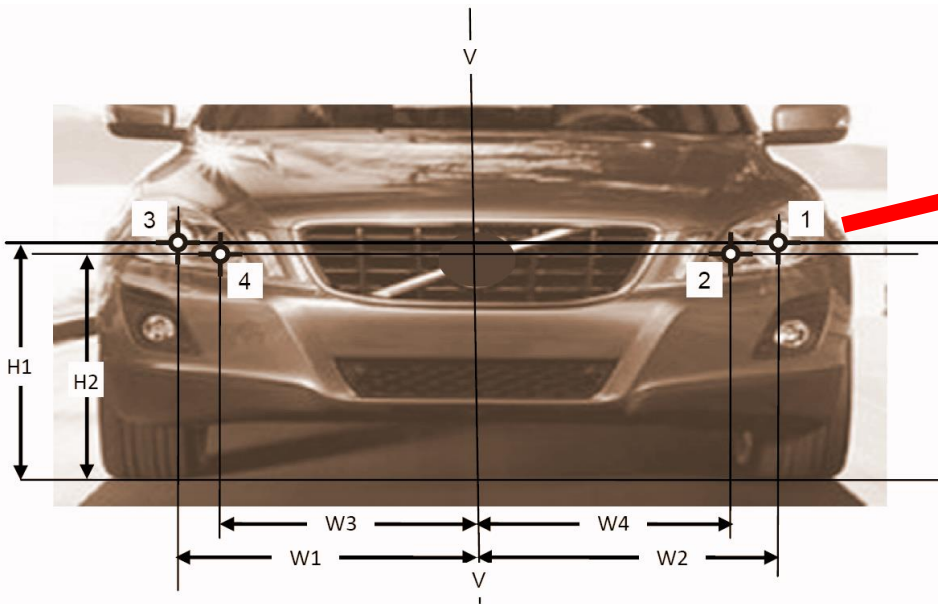

...by recording mounting positions  
and supply voltage on the car ...

...and by measuring the photometric  
values in a laboratory.

# CIE TC4-45

Performance Assessment Method  
for Vehicle Headlamps

---

## Headlamp Glare and Range in TC4-45 – Definition of Glare Zone

---



# CIE TC4-45

Performance Assessment Method  
for Vehicle Headlamps

## Headlamp Glare and Range in TC4-45 – Definition of Glare Zone

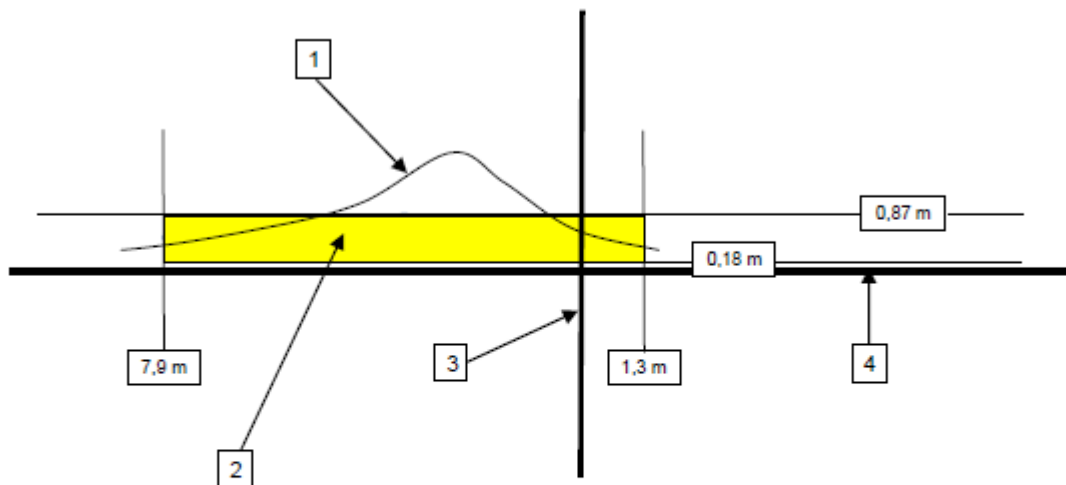

### Key

- 1 the curve indicates the probable location of the oncoming driver's eyes as a percentage of all instances on a range of road types based upon the work of Damasky [3]
- 2 for detail of this zone see Figure 16
- 3 vertical line through the longitudinal axis of vehicle
- 4 this horizontal line is located at a height of 0,75 m above the road surface

# CIE TC4-45

Performance Assessment Method  
for Vehicle Headlamps

## Headlamp Glare and Range in TC4-45 – Definition of Passing Beam Range



# CIE TC4-45

Performance Assessment Method  
for Vehicle Headlamps

## Headlamp Glare and Range in TC4-45 – Definition of Passing Beam Range

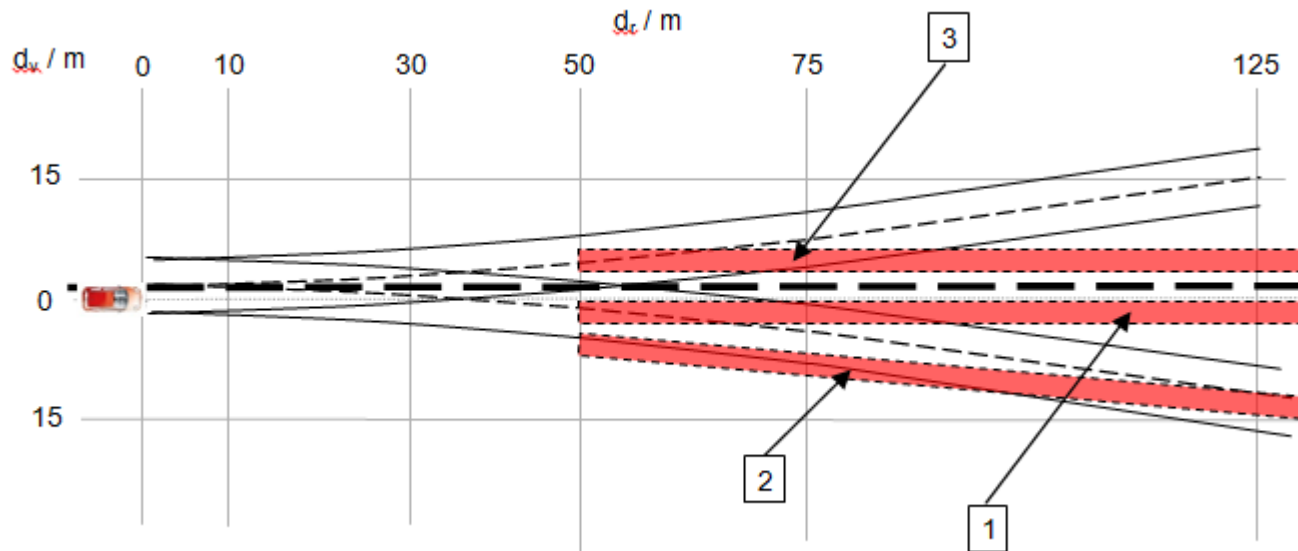

- $d_c$  distance along the road  
 $d_v$  distance from vehicle longitudinal axis
- 1 Zone A range assessment – straight road
  - 2 Zone B range assessment – curved road
  - 3 Zone C range assessment – pedestrian visibility

Road width 6m (3m per lane), 500m curve radius

# CIE TC4-45

Performance Assessment Method  
for Vehicle Headlamps

## Headlamp Glare and Range in TC4-45 – Definition of Passing Beam Range

### Zone A: Range of Passing Beam on a straight road

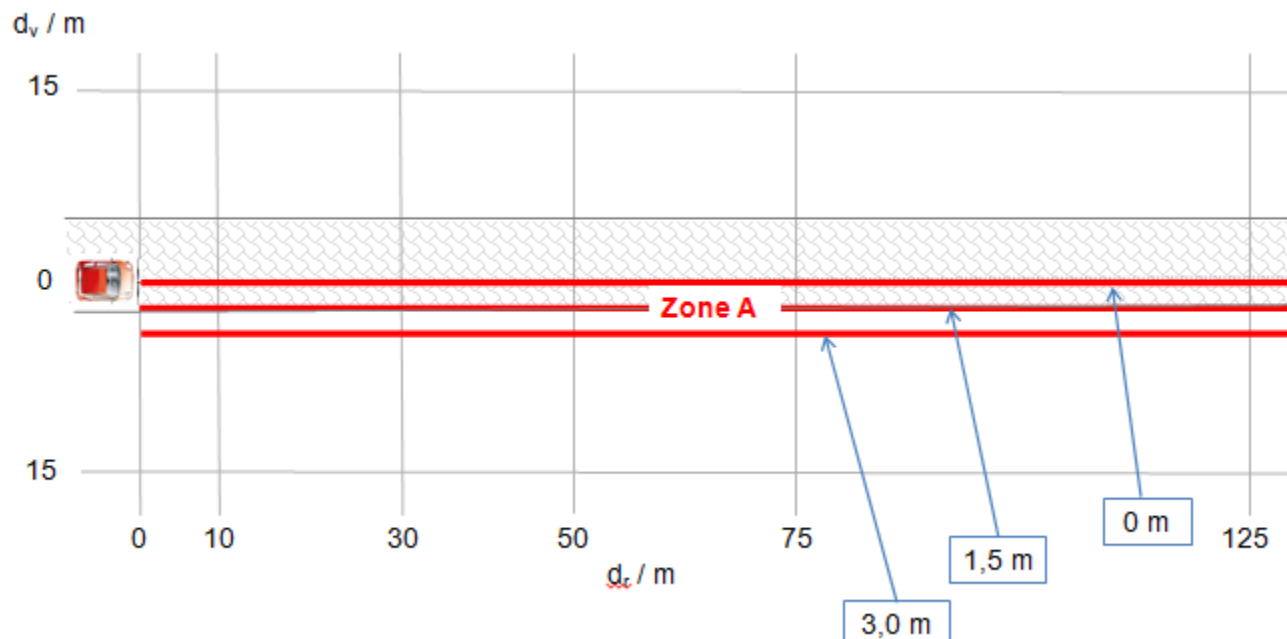

$d_c$  distance along the road  
 $d_v$  distance from vehicle longitudinal axis

NOTE The longitudinal lines in Zone A are situated at 0 m, 1,5 m and 3,0 m to the nearside of the longitudinal axis of the vehicle.

## Headlamp Glare and Range under different conditions

---

### Collection of data:

#### Glare and Range for headlamps

- with different types of light sources
- at different mounting heights



# CIE TC4-45

Performance Assessment Method  
for Vehicle Headlamps

## Luminous Flux in Glare Zone - H7, D3S and LED types of passing beams

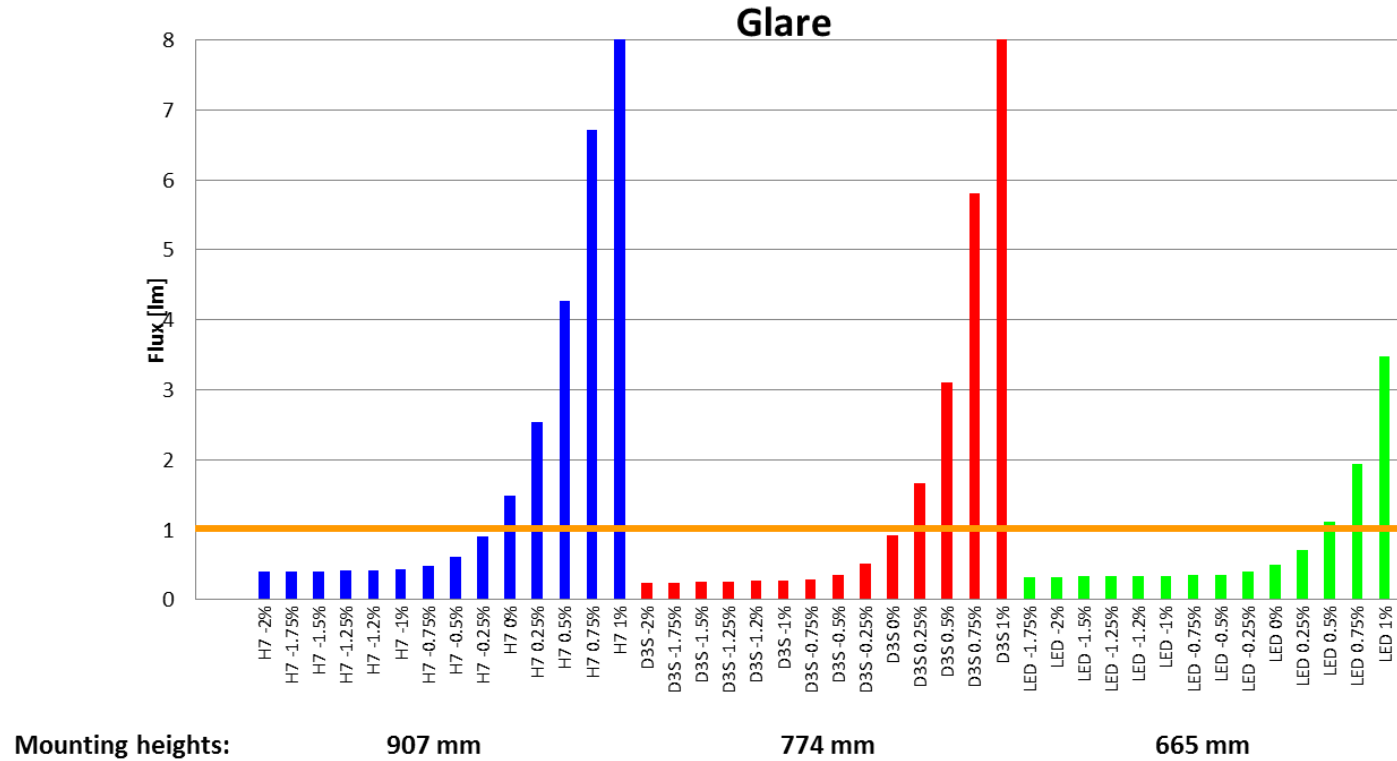

- vertical inclination of 0% means horizontal cut-off at H-H
- vertical inclination of -1,0% means horizontal cut-off 0,57° below H-H

# CIE TC4-45

Performance Assessment Method  
for Vehicle Headlamps

## Zone A - H7, D3S and LED types of passing beams

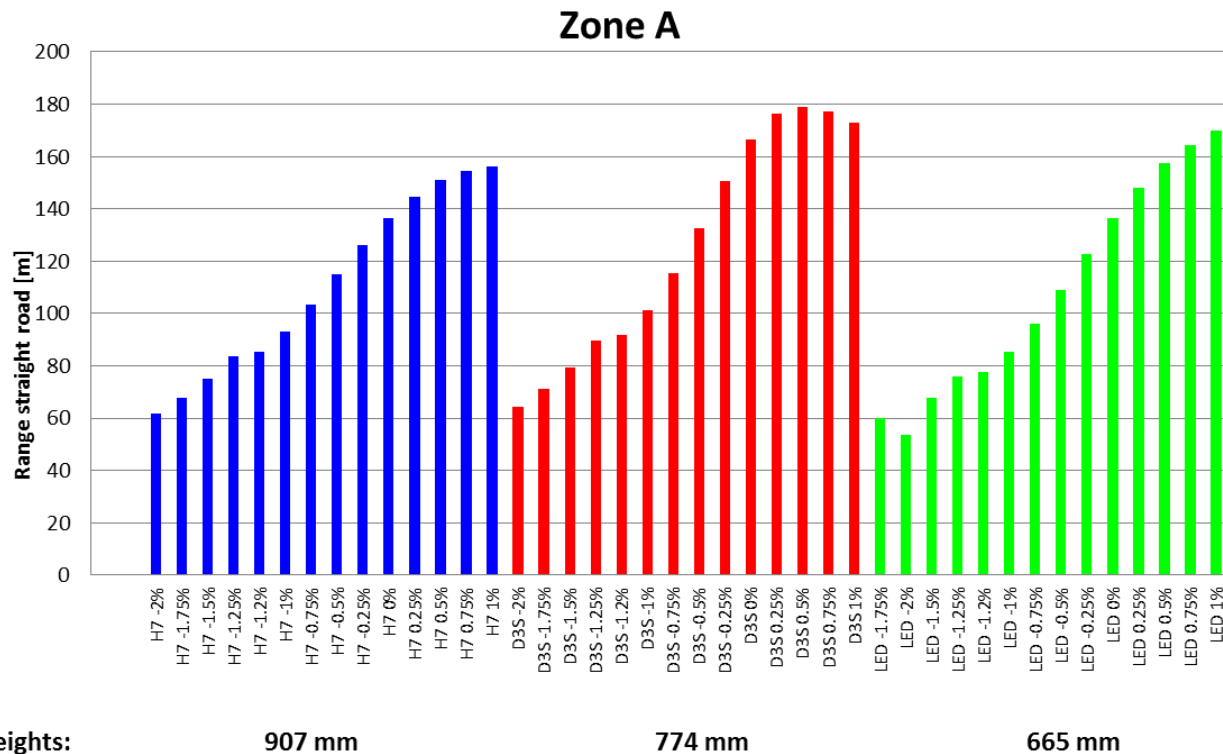

→ vertical inclination of 0% means horizontal cut-off at H-H

→ vertical inclination of -1,0% means horizontal cut-off 0,57° below H-H

# CIE TC4-45

Performance Assessment Method  
for Vehicle Headlamps

## Glare – H7 headlamp at different mounting heights

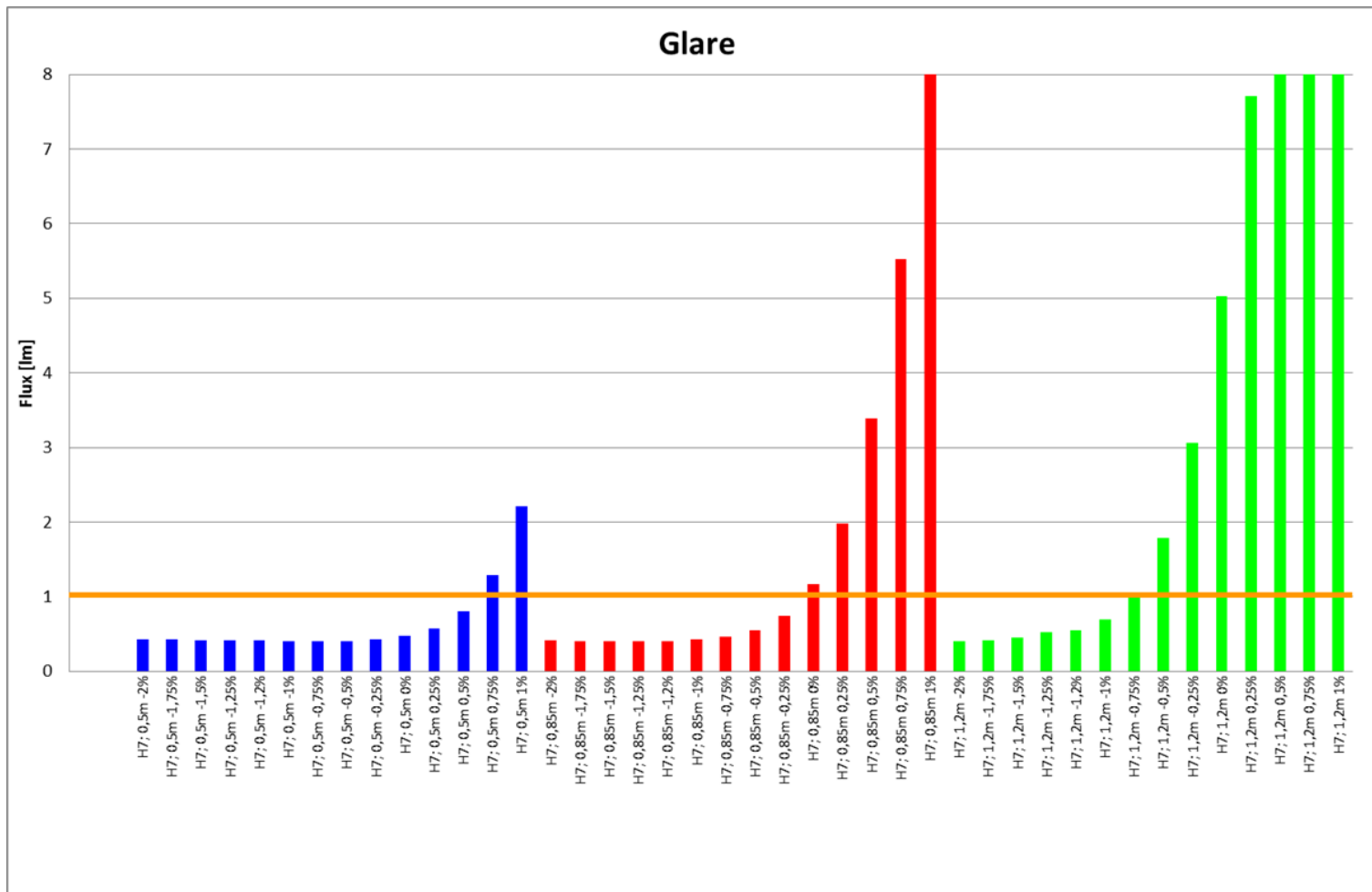

# CIE TC4-45

Performance Assessment Method  
for Vehicle Headlamps

## Glare – D3S headlamp at different mounting heights

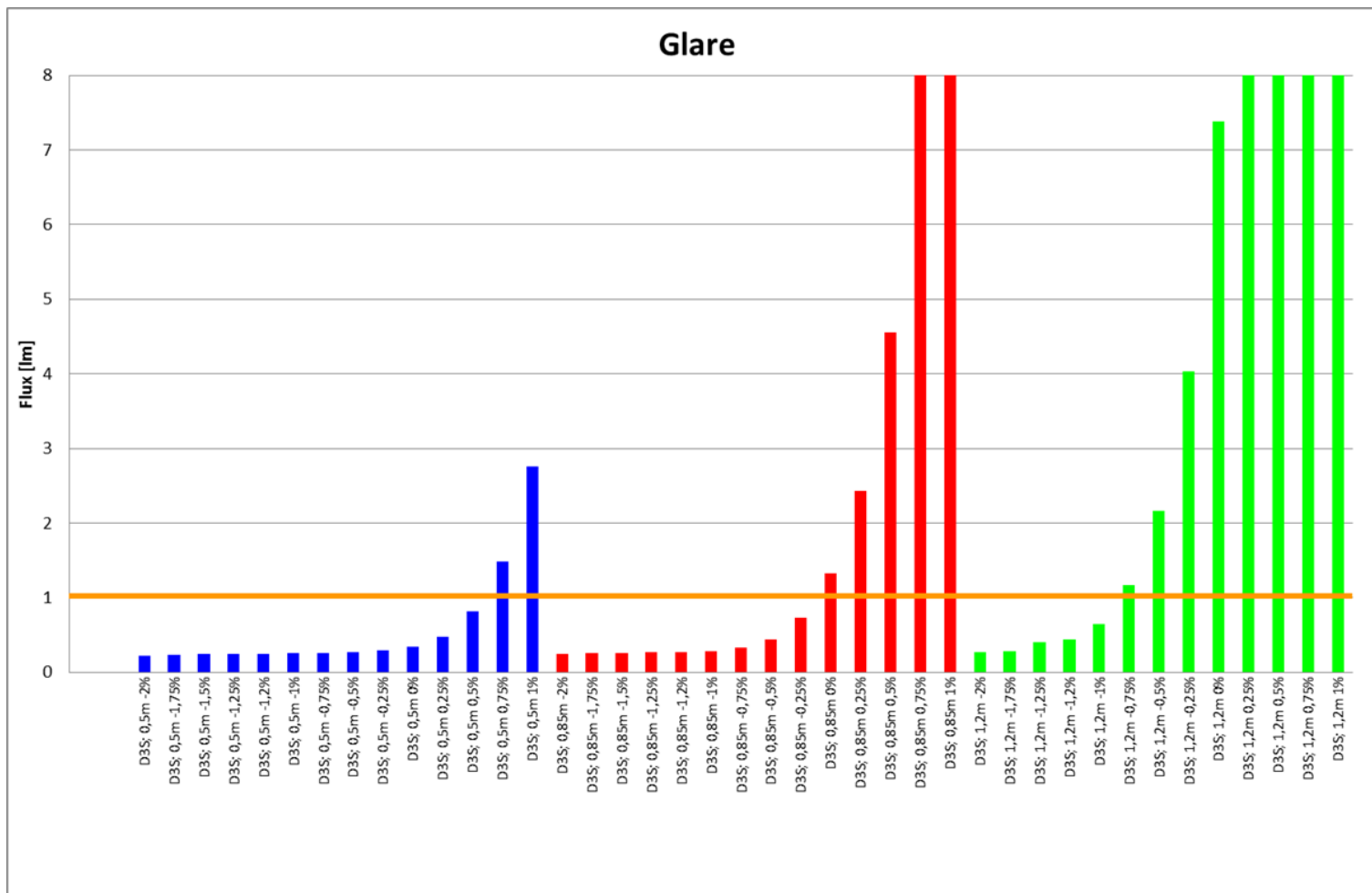

# CIE TC4-45

Performance Assessment Method  
for Vehicle Headlamps

## Glare – LED headlamp at different mounting heights

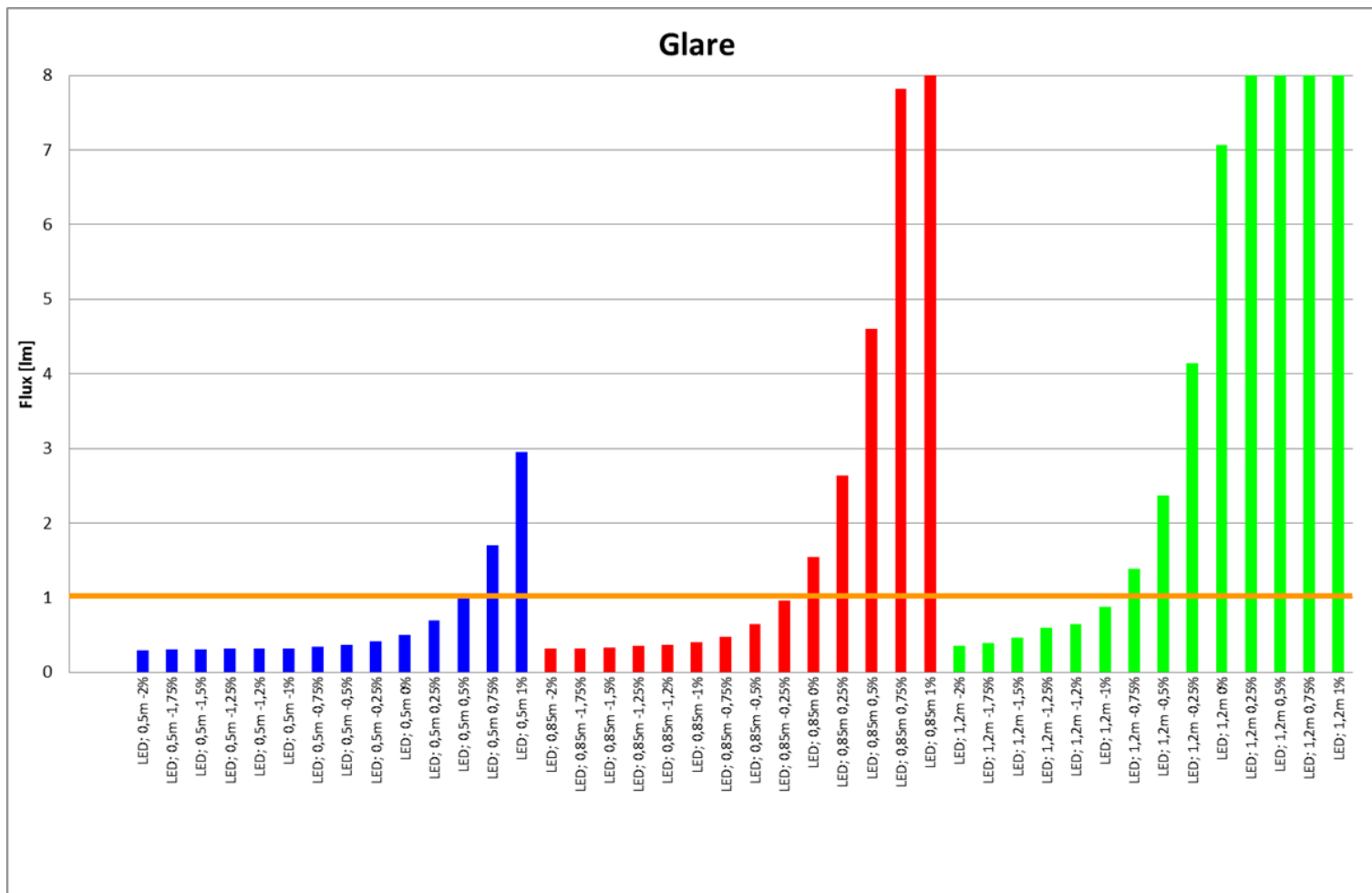

# CIE TC4-45

Performance Assessment Method  
for Vehicle Headlamps

## Range in Zone A – H7 headlamp at different mounting heights

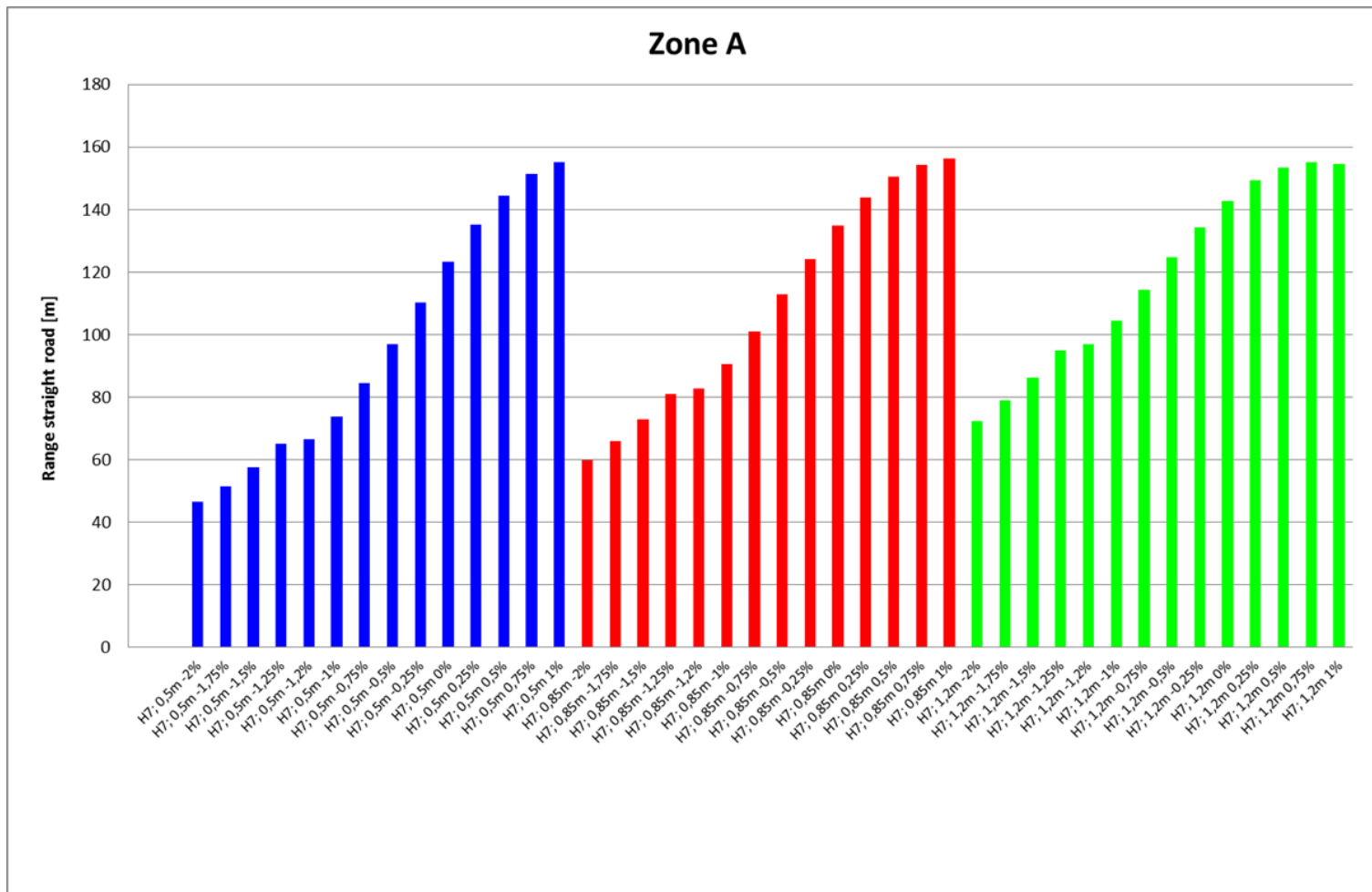

# CIE TC4-45

Performance Assessment Method  
for Vehicle Headlamps

## Range in Zone A – D3S headlamp at different mounting heights

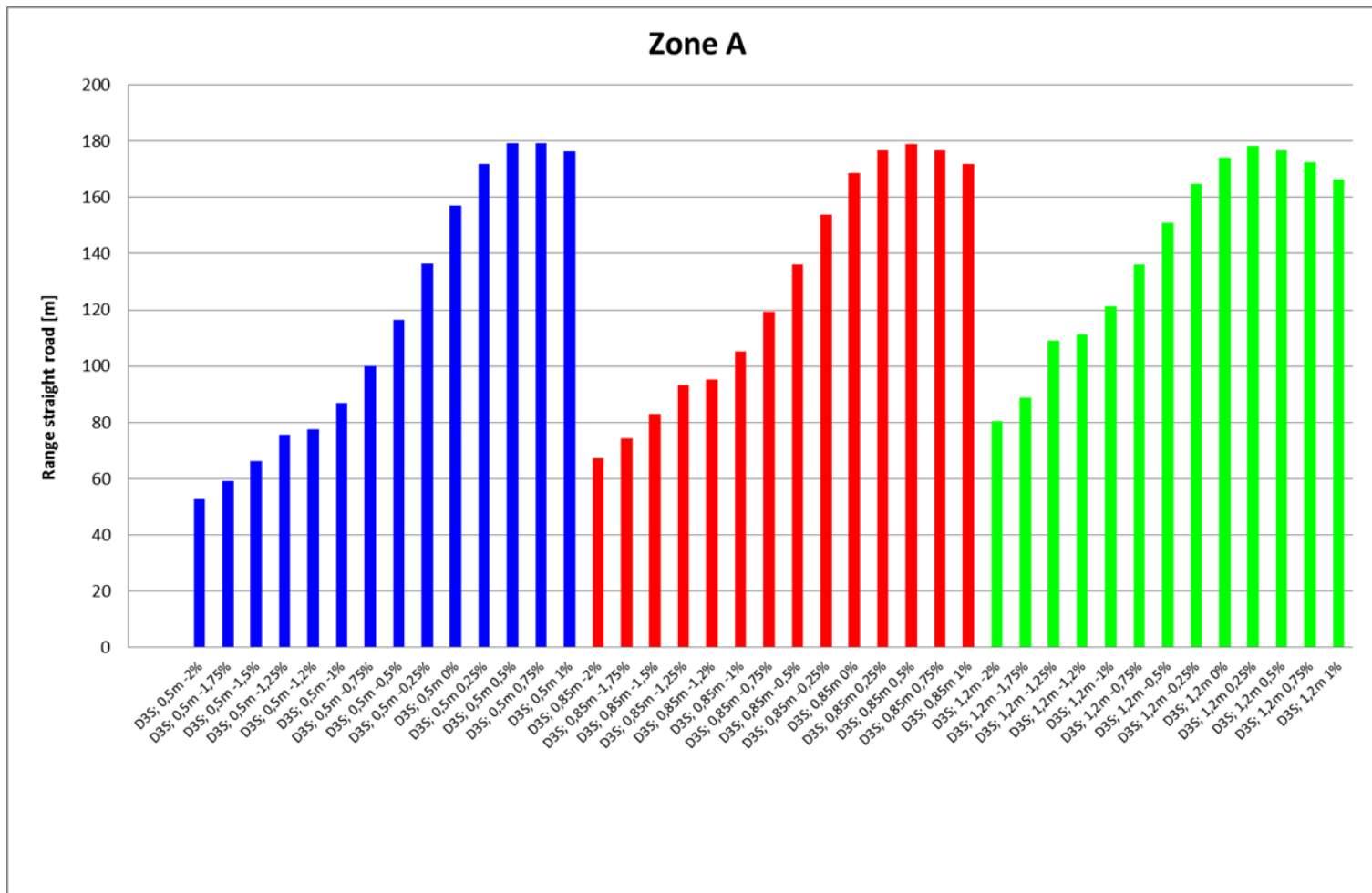

# CIE TC4-45

Performance Assessment Method  
for Vehicle Headlamps

## Range in Zone A – LED headlamp at different mounting heights

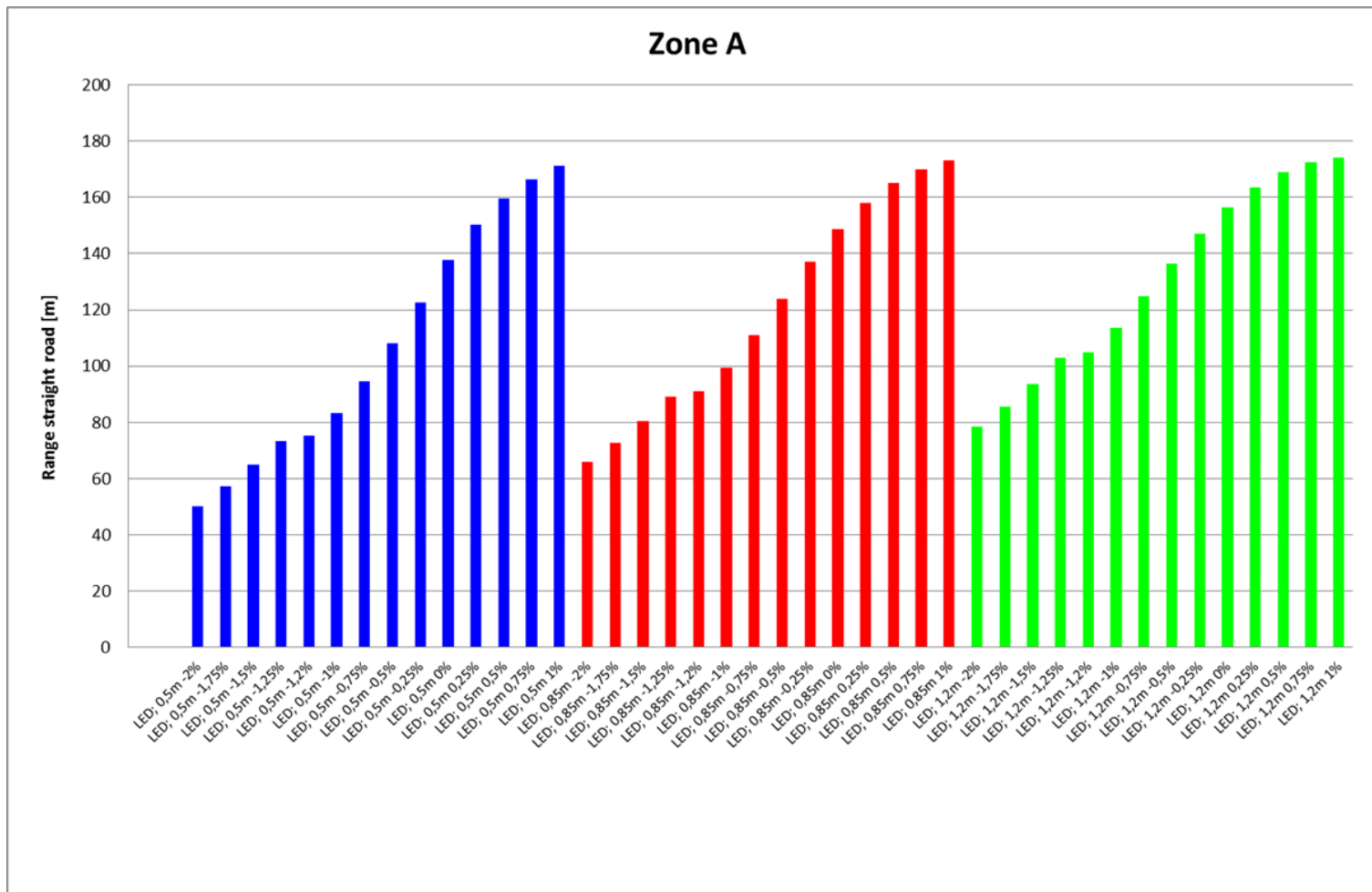



## Headlamp Glare and Range under different conditions

---

### Collection of data:

**Glare and Range for headlamps**

**at different initial aiming settings**

# CIE TC4-45

Performance Assessment Method  
for Vehicle Headlamps

## Glare – D3S headlamp at different initial aiming settings

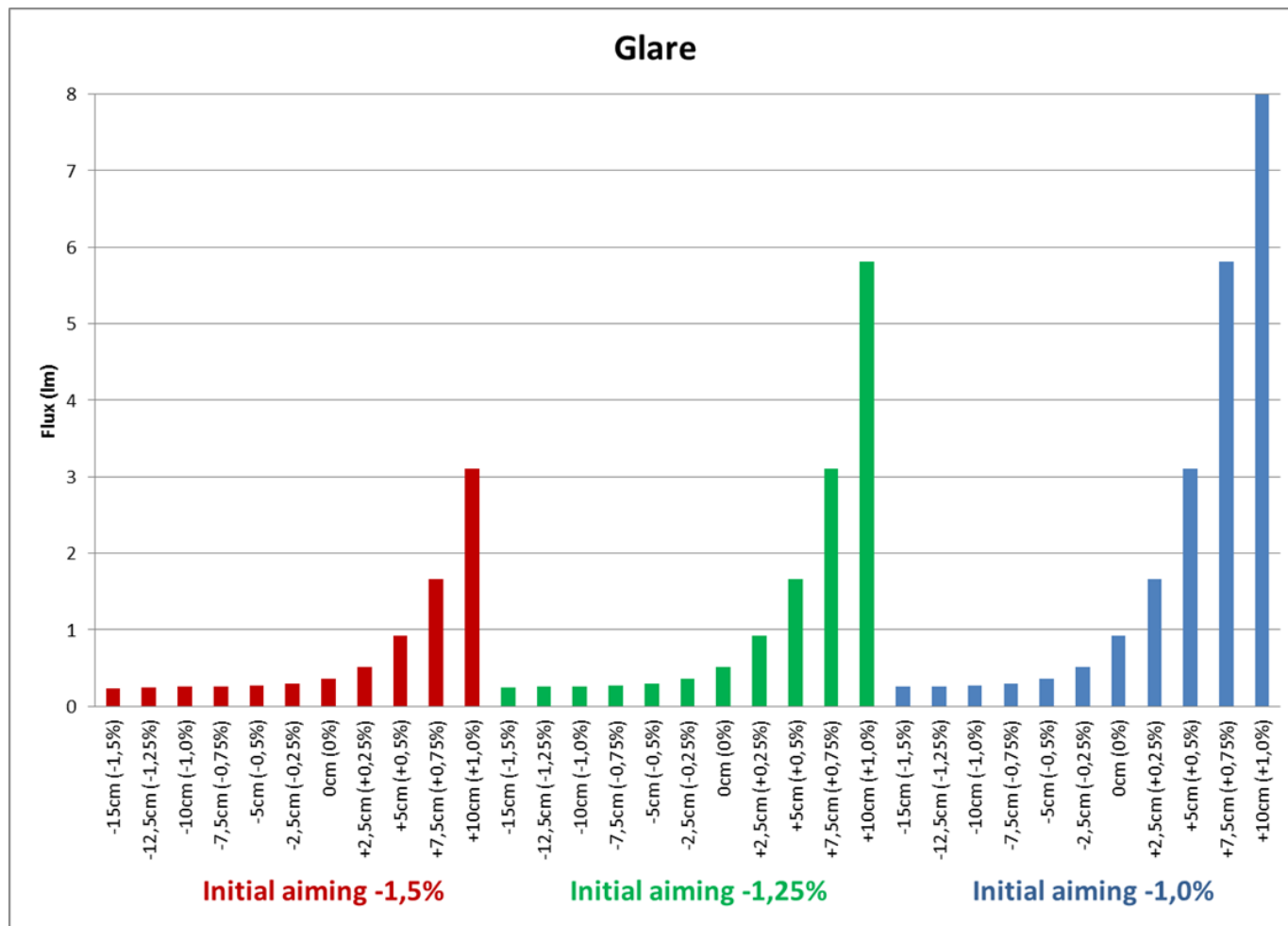

# CIE TC4-45

Performance Assessment Method  
for Vehicle Headlamps

## Range in Zone A – D3S headlamp at different initial aiming settings

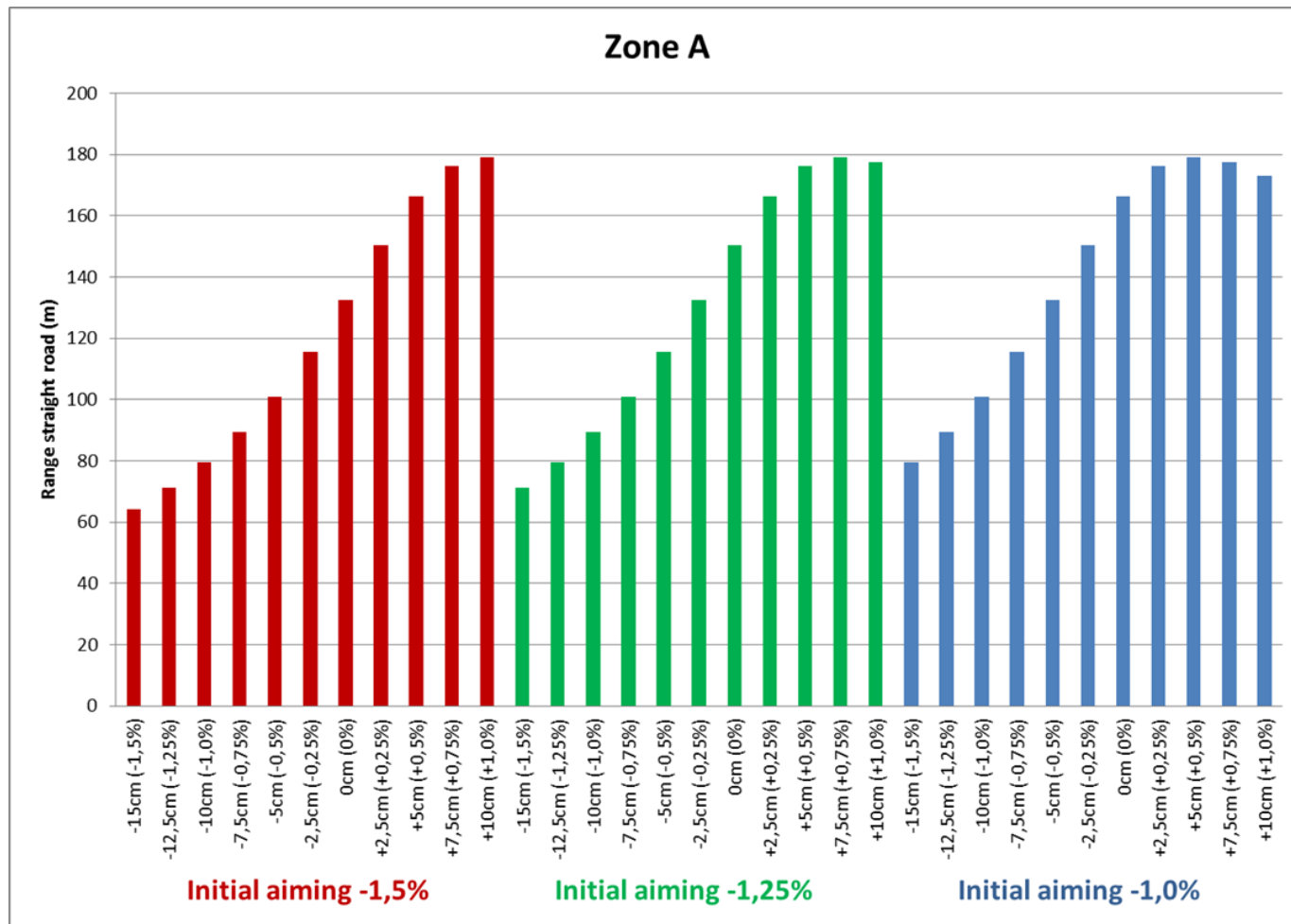

## Headlamp Glare

---

# Calculation Results in Relation to Klettwitz Field Test Outcome

## Headlamp Glare – correlation between de Boer and Luminous Flux

---

- The results of the Klettwitz field test show a clear relationship between pitch angle and discomfort glare.
- Pitch angles which lead to a passing beam cut-off movement above the horizon increase the discomfort glare for oncoming drivers – depending on the headlamps mounting height – to values below rating 5 („just admissible“) according to de Boer – scale.
- Cut-off positions above horizon lead – undependendly of light source types – to weighted luminous flux values in TC4-45 glare zone above 1 lumen.

# CIE TC4-45

Performance Assessment Method  
for Vehicle Headlamps

## Headlamp Glare – correlation between de Boer and Luminous Flux

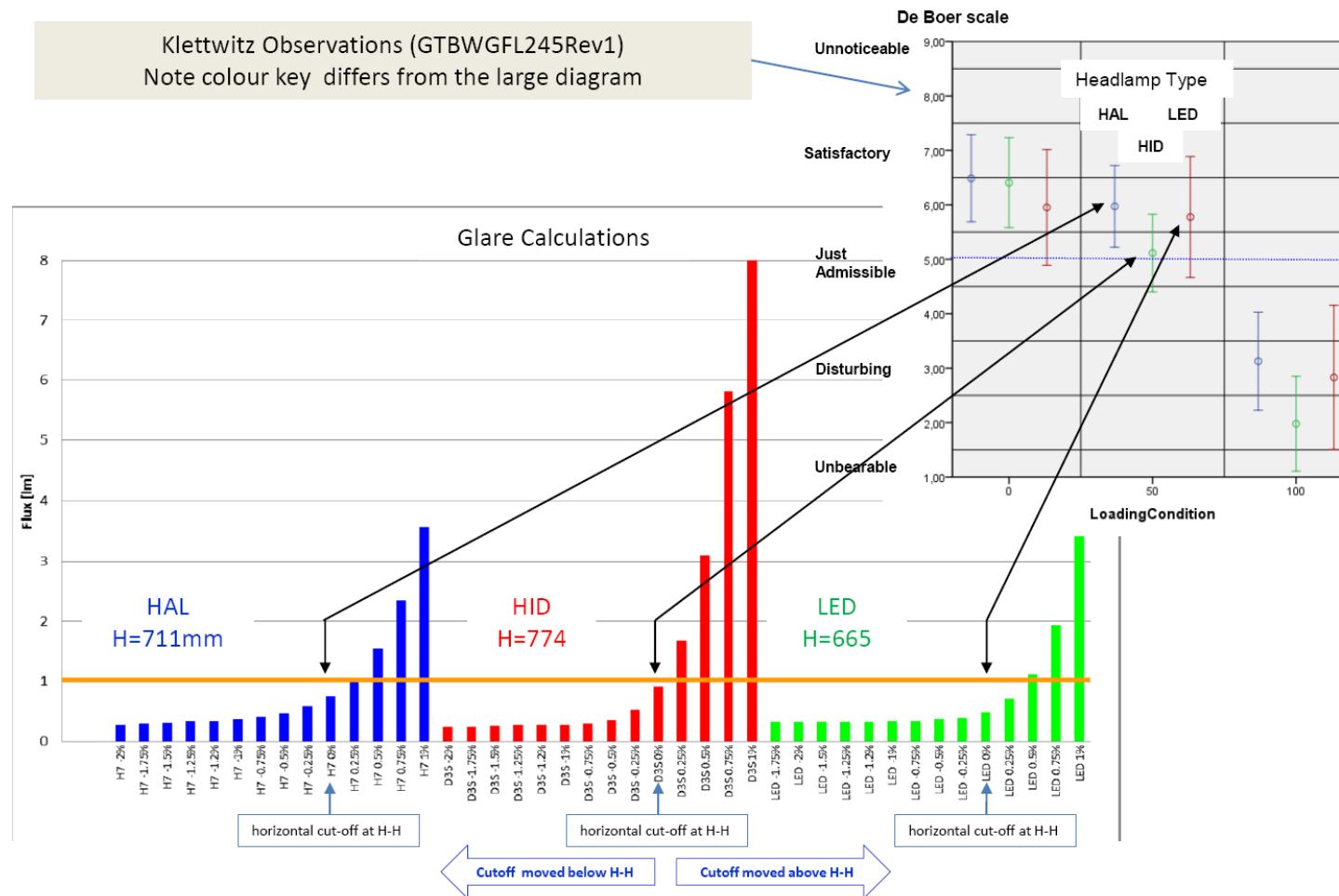

## Headlamp Glare – correlation between de Boer and Luminous Flux

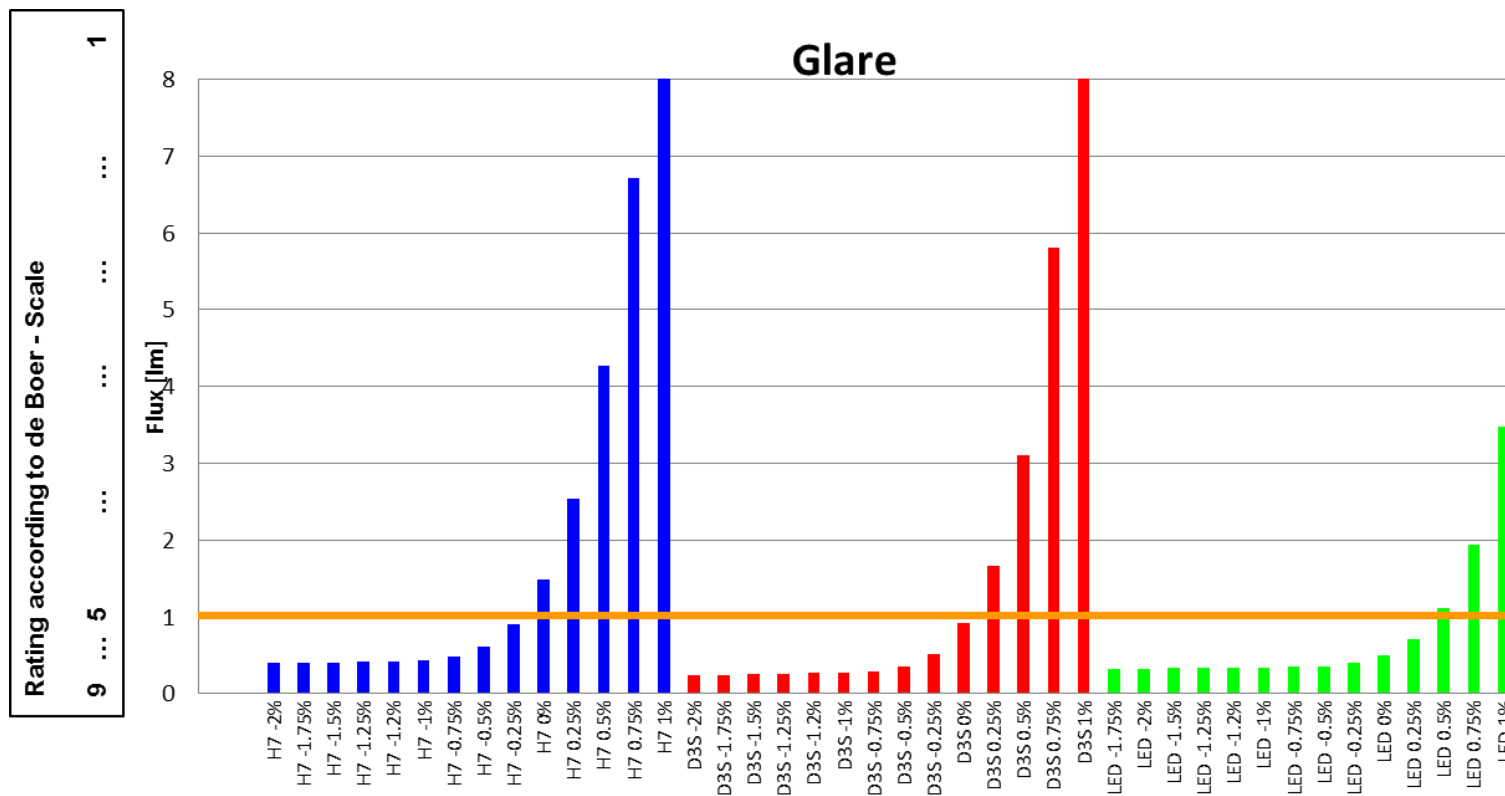

---

## Headlamp Glare – correlation between de Boer and Luminous Flux

---

- **Comparison of Klettwitz field test results and TC4-45 calculations leads to the conclusion that de Boer-Rating of „5 – just admissible“ correlates with a weighted luminous flux in TC4-45 glare zone of 1 lumen.**
- **This correlation opens the possibility to use TC4-45 glare calculations for the assessment of glare impact to oncoming drivers in real traffic situations.**



# Agenda

1. **GTB**

Introduction

2. **Poland**

Explanation of the background of the Polish proposal for R48

3. **GTB**

Literature Review

Night-time Field Test

Discussion

Comparison Klettwitz Outcome with Literature

Enrichment of Data by Calculation (CIE TC4-45)

4. **OICA**

Explanation of load conditions

5. **Joint GTB/Poland/OICA**

Conclusion

Suggestion

# Automatic Headlamp Levelling “50% Loading” Conditions

## LOADING CONDITIONS OF VEHICLES INVOLVED IN ACCIDENT ECE/TRANS/WP29/GRE/65/16

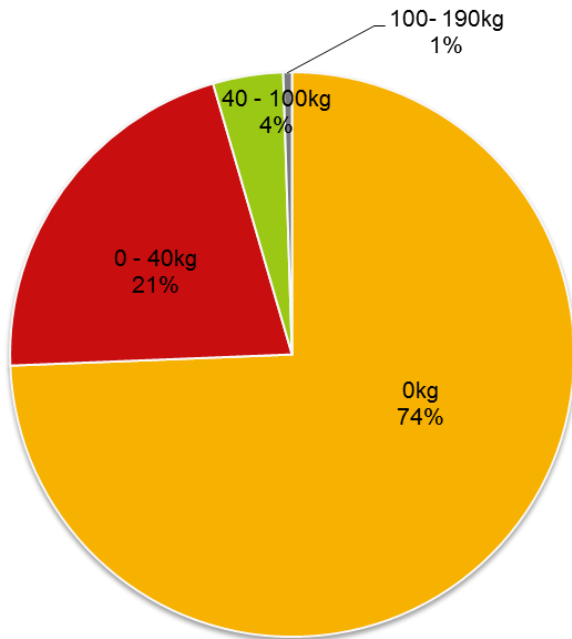

**Trunk load**

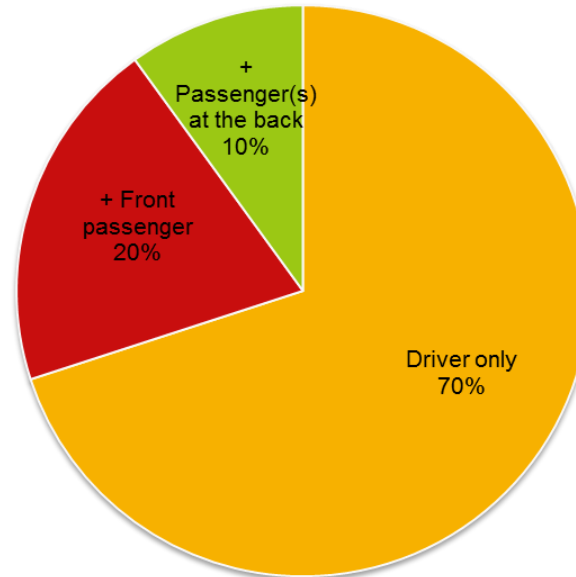

**Passengers load**

# CUSTOMER HABITS REGARDING LOAD IN VEHICLE'S TRUNK

## ECE/TRANS/WP29/GRE/65/16

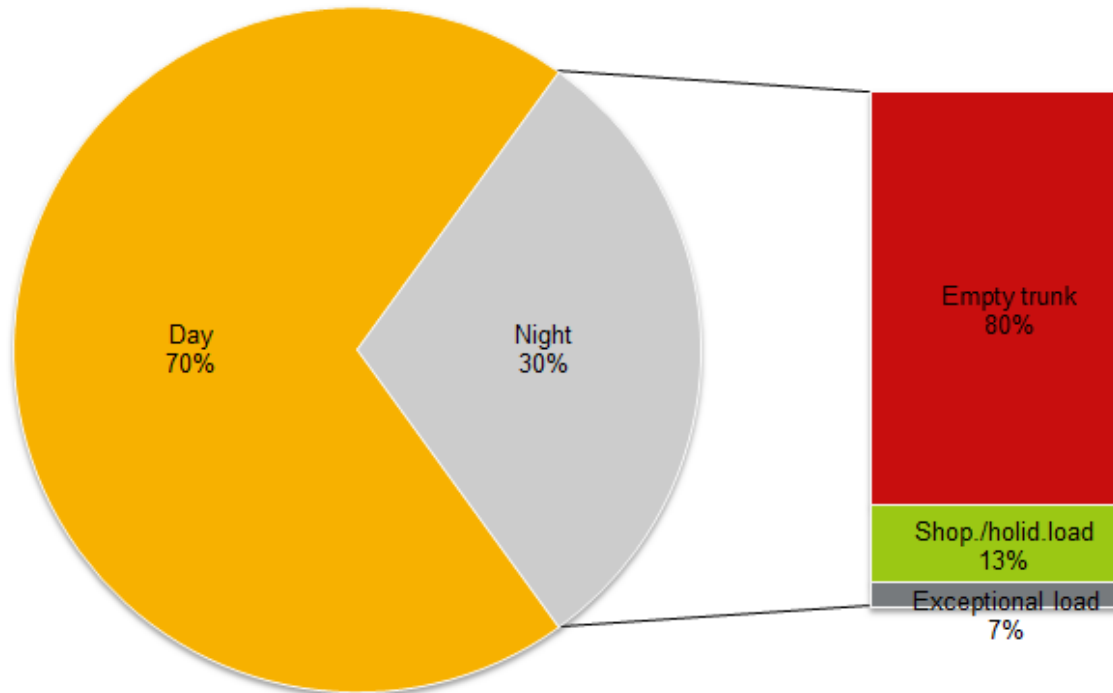

## DEFINITION OF “50% LOAD” CONDITION FOR A VEHICLE

- **Load Condition 0% :  $M_{0\%}$** 
  - **Mass of the vehicle with 90% min. fuel tank and 75kg driver**  
(as described in Reg. 48, paragraph 2.4 and Annex 6 paragraph 4.2 plus mass of the driver)
- **Load Condition 100% :  $M_{100\%}$** 
  - **Mass of the vehicle with maximum load authorized**  
(F1 information on Type Approval certificate)
- **Load Condition 50% :  $M_{50\%}$** 
  - $M_{50\%} = M_{0\%} + \left( \frac{M_{100\%} - M_{0\%}}{2} \right)$
- **The size of a 50% load  $\left( \frac{M_{100\%} - M_{0\%}}{2} \right)$  will be approximately 150kg to 300kg and is dependent on the vehicle type.**
  - From 74% to 99% of trunk load involved in accident
  - More than 90% of passengers load involved in accident

## “50% LOAD”- DISTRIBUTION IN THE VEHICLE

- **1 Passenger (75 kg) on the front seat**  
+
- **1 - 2 Passengers (75 kg + 75 kg) on the row closest to driver**  
+
- **Rest of the “50 % Load” in the trunk (if necessary)**

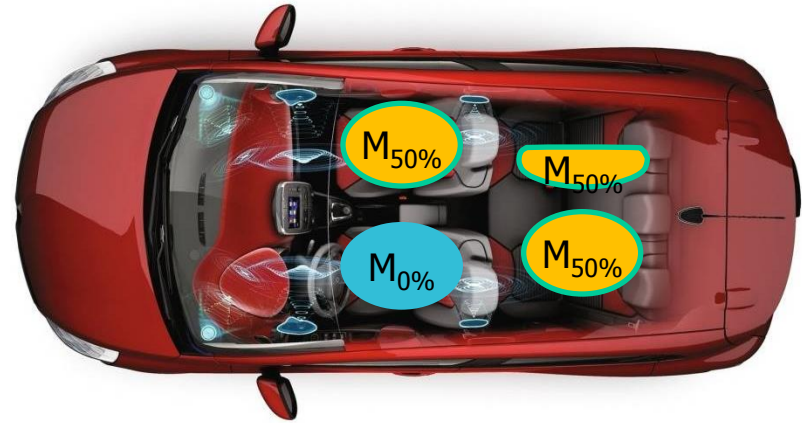

# Agenda

1. **GTB**

Introduction

2. **Poland**

Explanation of the background of the Polish proposal for R48

3. **GTB**

Literature Review

Night-time Field Test

Discussion

Comparison Klettwitz Outcome with Literature

Enrichment of Data by Calculation (CIE TC4-45)

4. **OICA**

Explanation of load conditions

5. **Joint GTB/Poland/OICA**

Conclusion

Suggestion

# Summary and Suggestion for Amendment to UN Regulation No. 48

Geoffrey R Draper - GTB President

*Headlamp levelling is a challenging subject because glare complaints are inherent to visibility of the road ahead for the driver.  
There is no perfect answer!*



# The Elements of the Glare and Visibility Range Puzzle

Today's presentation has considered:

- Visibility Range
  - The Polish approach
  - The GTB approach
- Acceptable Glare Limit
  - The GTB approach
  - The Polish approach
- The results of the comprehensive literature search
- Calculations using the CIE method based upon actual vehicle system data
- The Klettwitz tests clearly identifying the significance of vehicle pitch due to load
- The concept of “50% loading” resulting from French research data

## Focus on maintaining adequate visibility range

- Based upon the translation of the photometric requirements at the test points of the headlamp regulations into an estimate of values produced at points on the road surface.
- “Worst Case” – Takes account of lowest performing headlamps that meet the type approval requirements

## Avoidance of glare is not directly addressed

- Assumes that the horizontal cutoff should not extend beyond 100m distance from car.

Long debate at GRE resulting in the revised proposal GRE/2014/11

- Vehicle pitch is the influencing factor
- Glare remains acceptable providing the horizontal cutoff remains below the H-H line as defined in the headlamp regulations (Based on a mounting height of 750mm).
- It is necessary to consider the relationship between action to avoid glare complaints with the need to assure sufficient visibility range.
- The initial aim declared by the vehicle manufacturer becomes an important factor
- Data produced to enrich the Klettwitz results to validate the glare conclusions and investigate the relationship with visibility range
- Calculations using the CIE assessment method

## Example calculations using the CIE assessment method

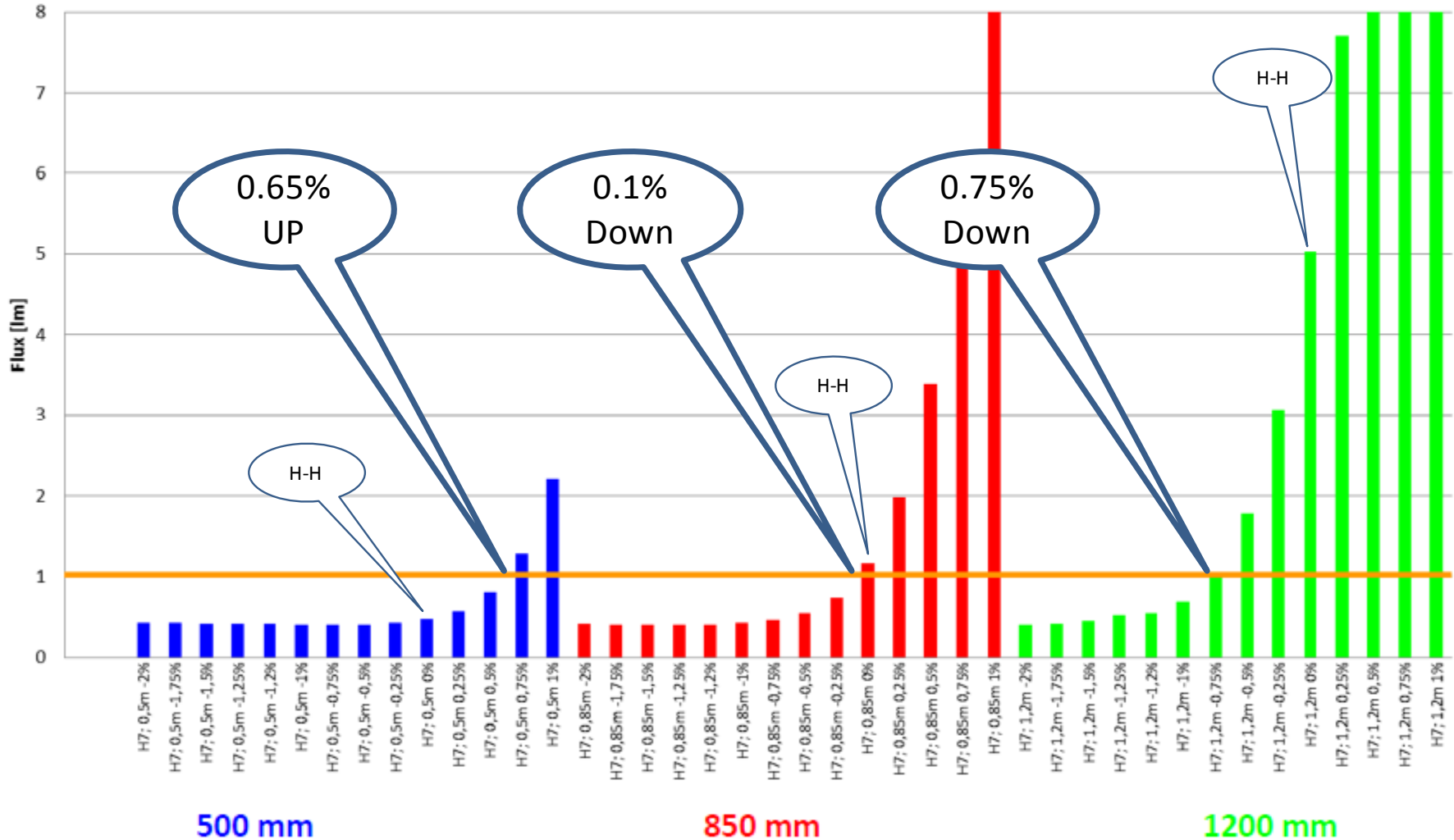

# Example calculations using the CIE assessment method

## Visibility Range Calculation

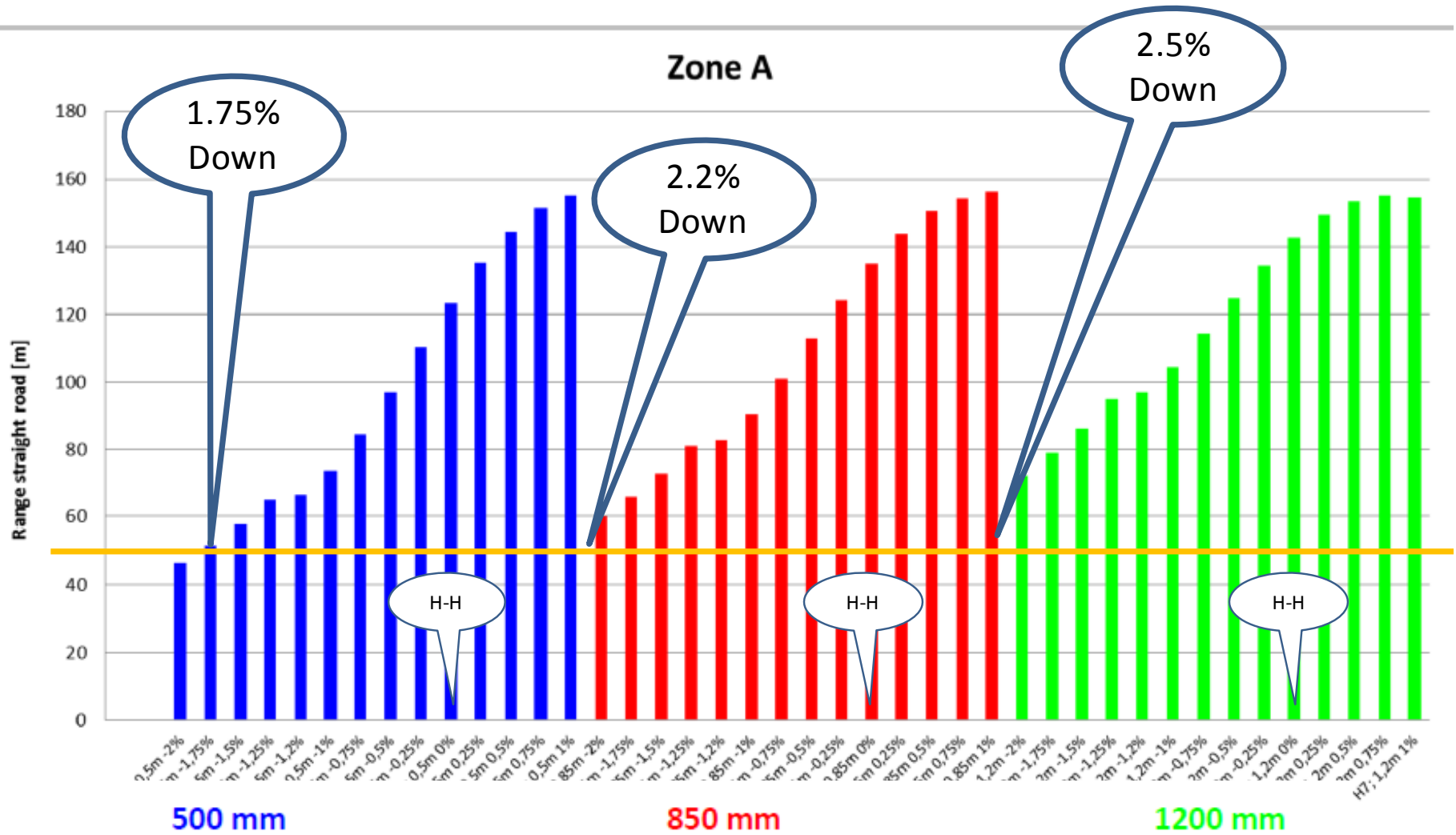

# GTB Proposal for Acceptable aiming limits

## Summary of Results of Glare and Visibility Calculations Based upon calculations using CIE method

Vertical Position of the Cutoff (+ = UP, - =Down)

Mounting Height	H7		D3S		LED	
	Glare	Visibility	Glare	Visibility	Glare	Visibility
500	0.65	-1.75	0.6	-2.2	0.5	-2
665					0.4	-2
744			0.12	-2.25		
850	-0.1	-2.25	-0.12	-2.25	-0.2	-2.5
907	-0.15	-2.25				
1200	-0.75	-2.5	-0.85	-3.25	-0.85	-3

The highlighted values indicate the position of the cutoff for the maximum permissible glare and the minimum permissible visibility range (i.e. The boundary conditions)

# GTB Proposal for Acceptable aiming limits

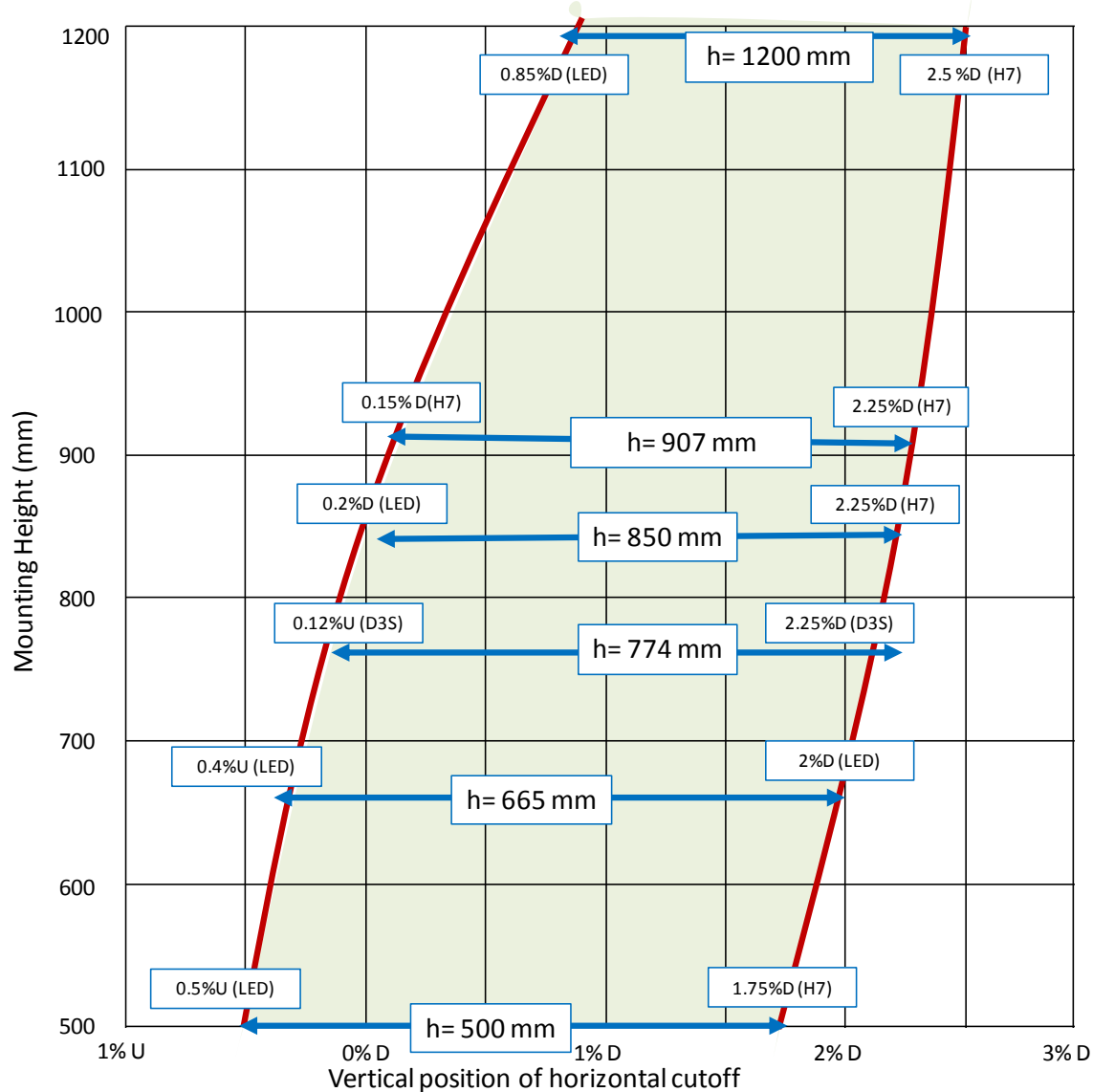

# GTB Proposal for Acceptable aiming limits

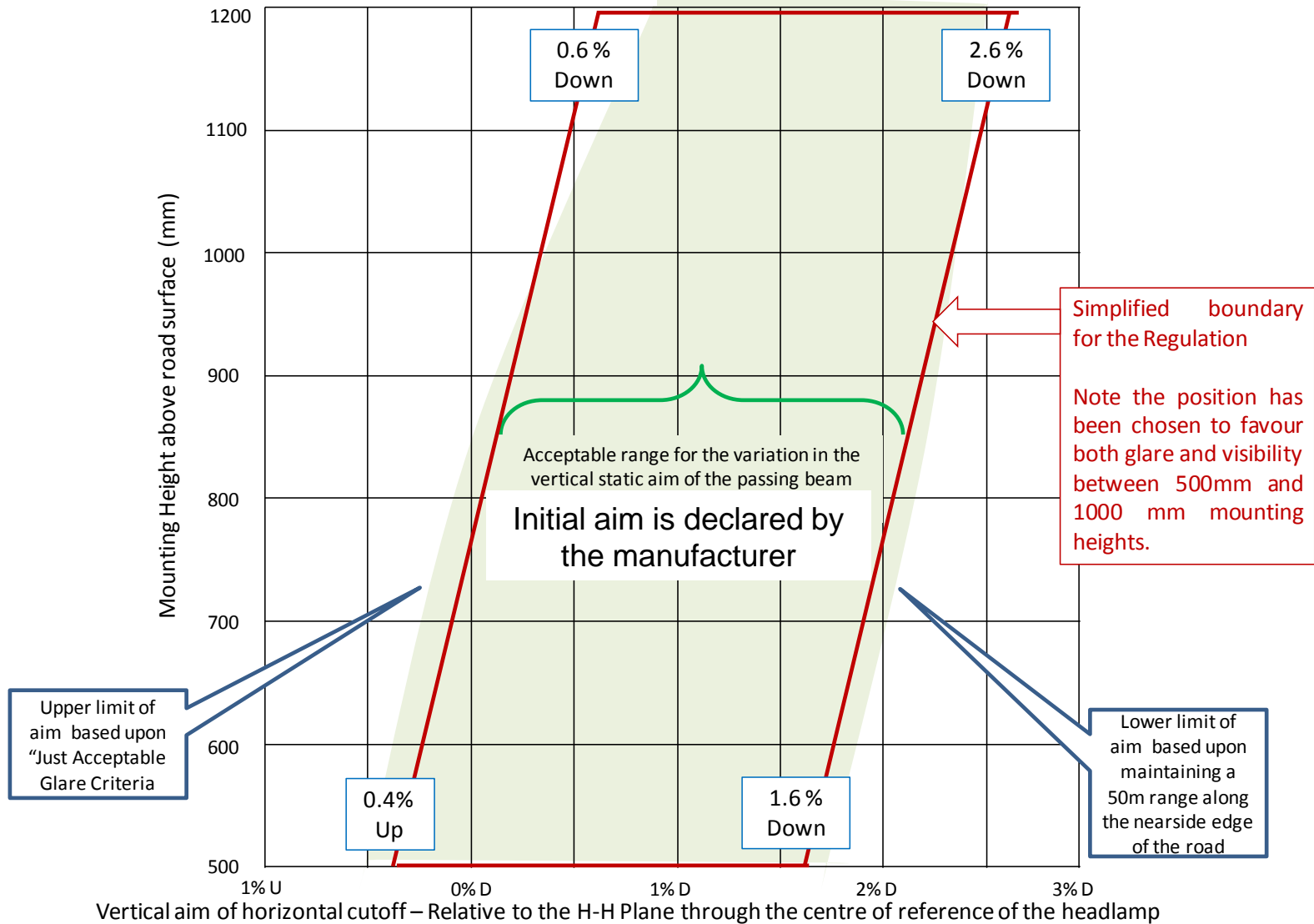



## How can we consider allowing the upper aiming limit to be above the H-H line?

- ✓ Vertical aim of horizontal cutoff is relative to the H-H plane through the centre of reference of the headlamp
- ✓ The headlamp height will vary between 500mm and 1200mm
- ✓ The mean height of the oncoming driver's eye is 1250mm
- ✓ Glare is assessed at a distance of 50m from the headlamp
- ✓ At 50m the important factor concerning glare is the separation of the oncoming driver's eye and the position of the horizontal cutoff
- ❑ This factor has not been taken into account in the current R48 requirements

# Angular relationship of horizontal cutoff and oncoming driver's eye

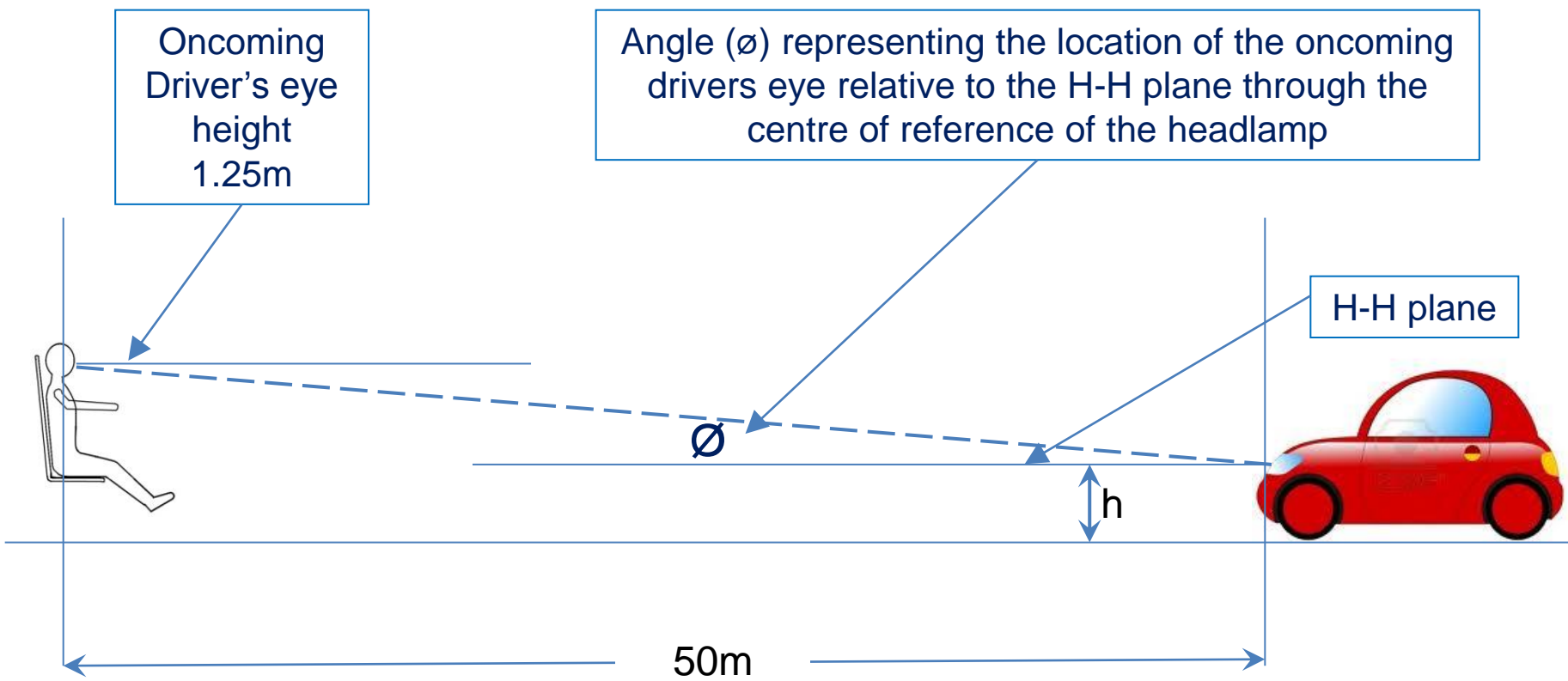

Height of oncoming driver's eye	1250	1250	1250	1250	1250	1250	1250	1250
Headlamp mounting height mm	500	600	700	800	900	1000	1100	1200
angular difference $\varnothing$ - %	1.5	1.3	1.1	0.9	0.7	0.5	0.3	0.1

# GTB proposal with oncoming driver's eye position superimposed

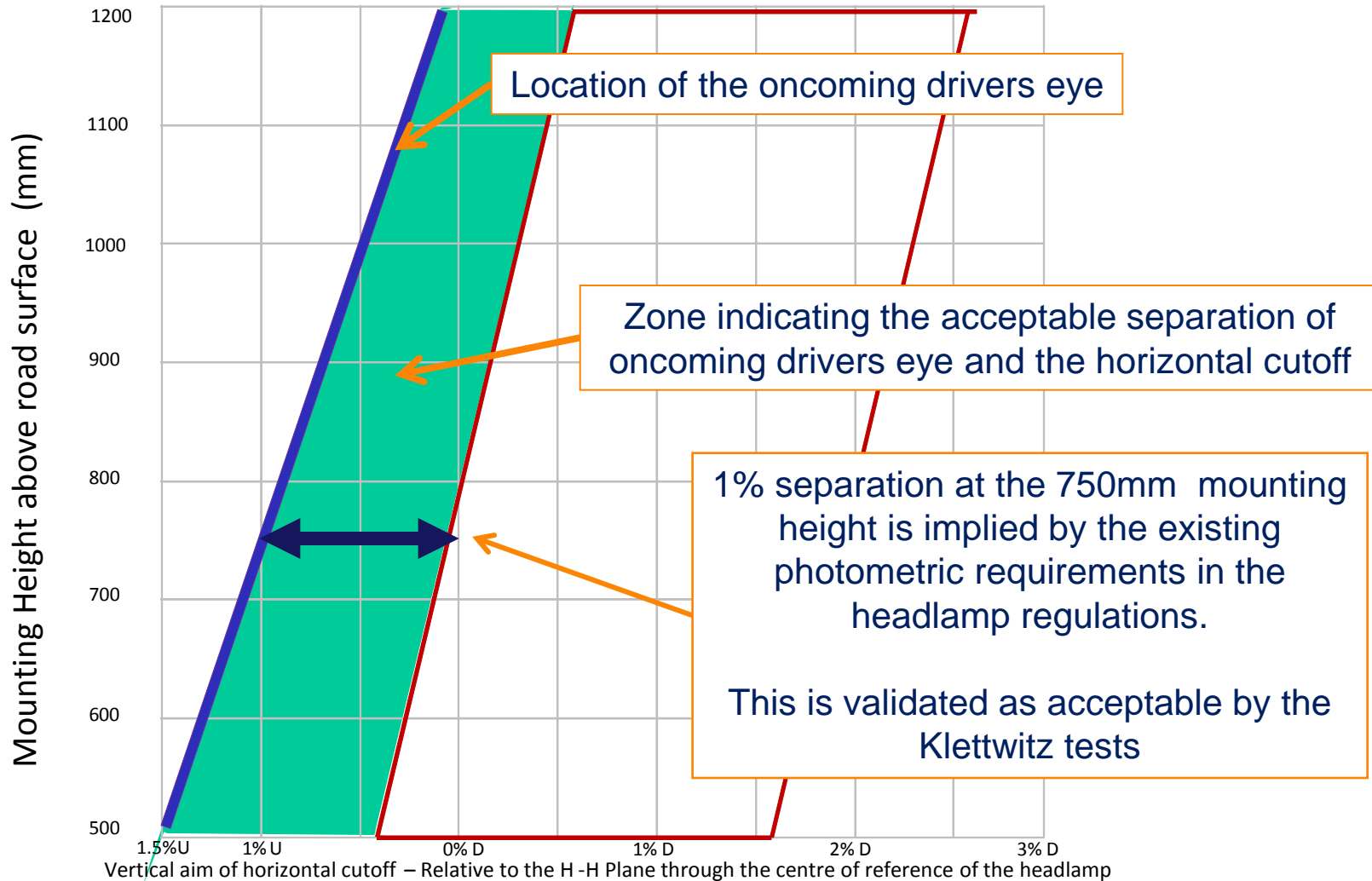

# GTB Proposal for Acceptable aiming limits

## How can we consider raising the upper glare limit when there are already glare complaints from road users?

- ✓ The proposed GTB upper aiming limit is based upon research reported in the CIE188: 2010. This established a correlation between the calculated light flux in the glare zone and observations using the De Boer scale.
- ✓ A similar correlation was found between the calculations and the observations in the Klettwitz tests.
- ✓ Glare complaints are common but there are no data to show the relationship between initial aim and glare complaints, despite studies in Europe and USA
- ✓ Current R48 requirements have assumed HID headlamps will create more glare and are required to have auto-levelling. Klettwitz tests and calculations show that halogen headlamps produce higher values in the CIE glare zone. Halogen headlamps are rarely installed with auto levelling.

# GTB Proposal for Amendment to R48

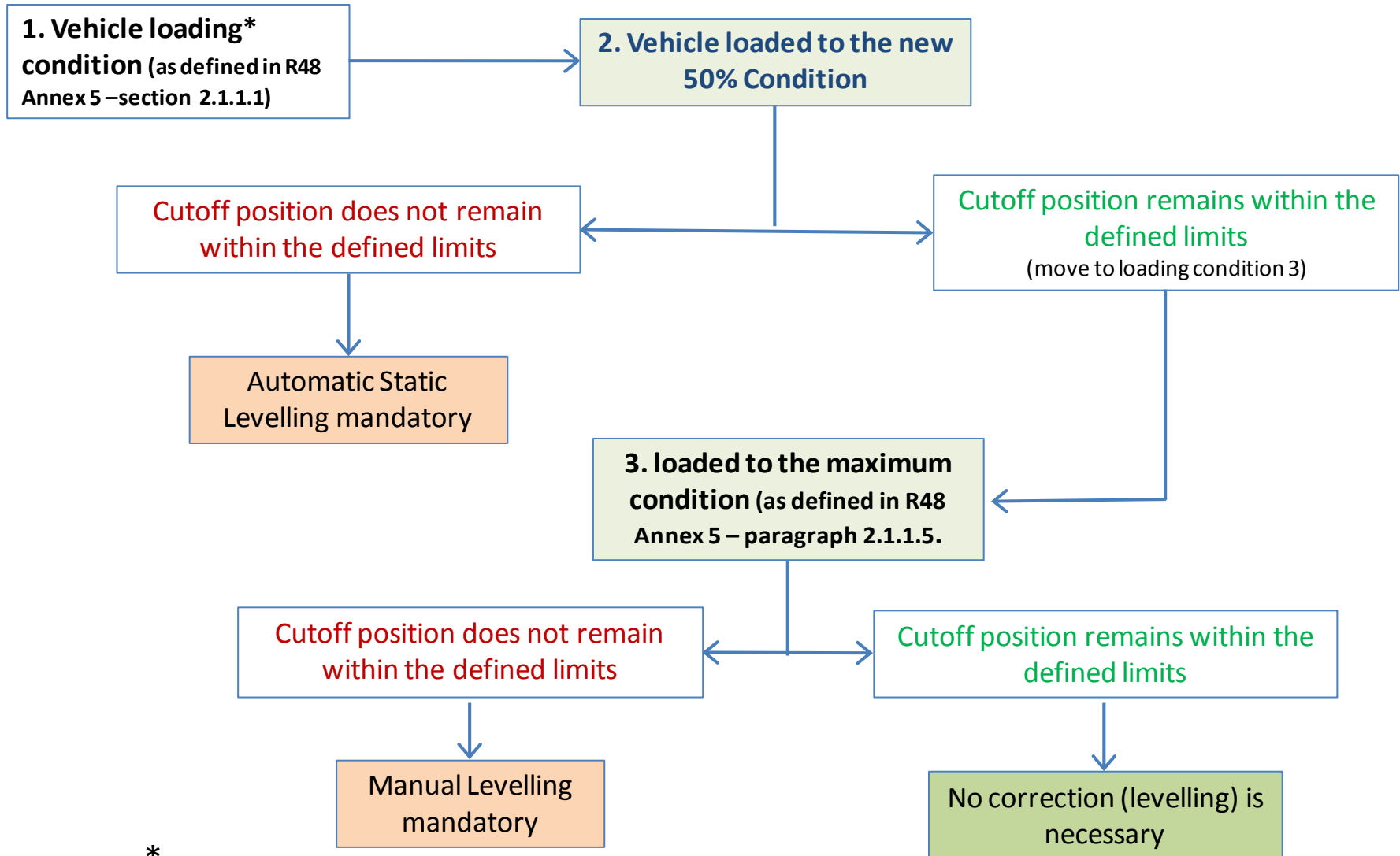

\* Note the mass of the passengers shall be 75 kg per person.

# Comparison of Polish & GTB Proposals with Current R48

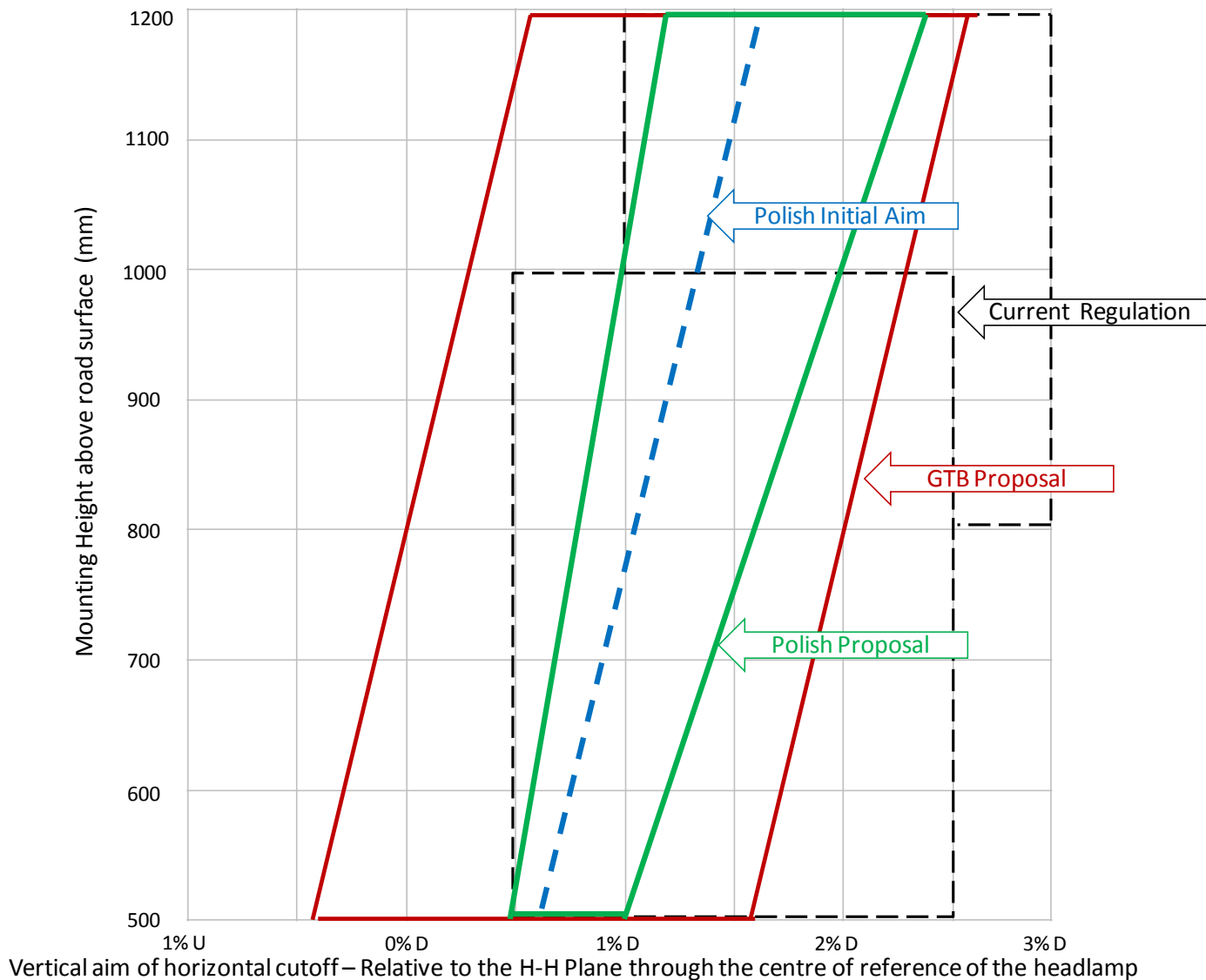

# The Polish Proposal

- based upon current photometric requirements of the headlamp regulations defines the aiming limits that have to be respected for all loading conditions described in R48 Annex 5.
- intended to apply to all vehicle installations that will use any headlamp type approved to the existing headlamp regulations.
- assumes that the horizontal cutoff levelling tolerances are such that:
  - a) to achieve adequate range the position of the cutoff does not exceed the maximum allowed downward inclination corresponding to a point on the road at 50 m distance.
  - b) for glare avoidance the position of the cutoff does not exceed a vertical position that corresponds to a point on the road at 100 m distance from the car. In this condition the glare values at the oncoming driver's eye are assumed to not significantly exceed the values specified in the headlamp regulations.
- results in tolerances that are significantly smaller than those currently allowed in Regulation 48.

- based upon headlamp systems typical of the standard of performance currently achieved in popular Western European and Japanese type approved vehicles.
- these headlamps are achieving performance levels in excess of the minimum requirements of the headlamp regulations.
- does not attempt to represent the worst-case situation as is represented by the Polish proposal.
- glare and visibility range values have been determined by calculations based upon actual measured headlamp performance data, using the CIE validated method.
- result is a proposal for aiming tolerances that are similar to those currently specified in Regulation 48 but with an upward shift.
- requires the vehicle manufacturer to declare the vehicle pitch under the specified loading conditions at the early design stage.



The GTB and Polish proposals present possibilities:

- ❖ Determine and declare the pitch characteristics of the vehicle at the time of type approval and confirm compliance with the aiming tolerances in the GTB proposal, or:
- ❖ Apply for a type approval without the requirement to declare the pitch characteristics and confirm compliance with the levelling tolerances in the Polish proposal.

Depending upon the reaction of GRE:

- |            |   |
|------------|---|
| April 2014 | Presentation to GRE / feedback from GRE experts   |
| May 2014   | GTB ready for preparation of proposals to amend the text of Reg.48 including revision to annex 5 loading conditions (GTB Meeting – Spain) |
| July 2014  | Deadline for submission of formal proposals to GRE-72   |

# GTB Task Force

## Coordination of **A**utomotive **V**isibility and **G**lare **S**tudies

Thank you for your attention

