

## **Supporting document to the proposal from the IWG ACV**

This document has been compiled by the experts of the informal working group ACV in order to make relevant background information available to the experts of the GRRF

In the proposal from the IWG ACV the standard ISO13044-2:2013 is referenced. This standard has in the ISO process passed the “FDIS-stage”, i.e. it is approved and will just be proof read before publication. At the “FDIS-ballot” the approval was solid. However there was only one country, UK, voting against. The remarks accompanying the UK vote has been processed by the ISO/TC22/SC15 secretariat. This processing resulted in the proof reading version getting a correction of a typing error. The ISO13044-2 FDIS together with the UK remarks, commented by the secretary is included below.

FINAL  
DRAFT

INTERNATIONAL  
STANDARD

ISO/FDIS  
13044-2

ISO/TC 22/SC 15

Secretariat: UNI

Voting begins on:  
2013-03-12

Voting terminates on:  
2013-05-12

---

---

## Road vehicles — Fully automatic coupling systems 24 V (FACS) for heavy commercial vehicle combinations —

### Part 2: 50 mm fifth wheel couplings — Electrical and pneumatic interface

*Véhicules routiers — Dispositifs d'attelage entièrement automatiques 24 V (FACS) pour ensembles routiers lourds —*

*Partie 2: Sellettes d'attelage pour pivot de 50 mm — Interface électrique et pneumatique*

RECIPIENTS OF THIS DRAFT ARE INVITED TO SUBMIT, WITH THEIR COMMENTS, NOTIFICATION OF ANY RELEVANT PATENT RIGHTS OF WHICH THEY ARE AWARE AND TO PROVIDE SUPPORTING DOCUMENTATION.

IN ADDITION TO THEIR EVALUATION AS BEING ACCEPTABLE FOR INDUSTRIAL, TECHNOLOGICAL, COMMERCIAL AND USER PURPOSES, DRAFT INTERNATIONAL STANDARDS MAY ON OCCASION HAVE TO BE CONSIDERED IN THE LIGHT OF THEIR POTENTIAL TO BECOME STANDARDS TO WHICH REFERENCE MAY BE MADE IN NATIONAL REGULATIONS.



Reference number  
ISO/FDIS 13044-2:2013(E)

© ISO 2013



**COPYRIGHT PROTECTED DOCUMENT**

© ISO 2013

All rights reserved. Unless otherwise specified, no part of this publication may be reproduced or utilized otherwise in any form or by any means, electronic or mechanical, including photocopying, or posting on the internet or an intranet, without prior written permission. Permission can be requested from either ISO at the address below or ISO's member body in the country of the requester.

ISO copyright office  
Case postale 56 • CH-1211 Geneva 20  
Tel. + 41 22 749 01 11  
Fax + 41 22 749 09 47  
E-mail [copyright@iso.org](mailto:copyright@iso.org)  
Web [www.iso.org](http://www.iso.org)

Published in Switzerland

# Contents

	Page
<b>Foreword</b> .....	<b>iv</b>
<b>Introduction</b> .....	<b>v</b>
<b>1 Scope</b> .....	<b>1</b>
<b>2 Normative references</b> .....	<b>1</b>
<b>3 Terms and definitions</b> .....	<b>2</b>
<b>4 Requirements</b> .....	<b>2</b>
4.1 General.....	2
4.2 Tractor and semi-trailer.....	3
4.3 Mechanical interface, Manual operation.....	3
4.4 EPI module.....	3
4.5 Mating of the two EPI parts.....	3
4.6 Guiding and alignment.....	4
4.7 Encapsulation and protection.....	6
4.8 Automation of landing legs.....	7
4.9 ISO 11992 Cable length.....	7
4.10 Mixed mode operation.....	7
<b>5 Tests and specific requirements</b> .....	<b>7</b>
5.1 General.....	7
5.2 Visual examination.....	8
5.3 Dimensional check.....	8
5.4 Connection and disconnection.....	8
5.5 Locking device operation.....	9
5.6 Current carrying capacity.....	9
5.7 Connection resistance (voltage drop), cable capacitance and pneumatics.....	9
5.8 Current cycling.....	11
5.9 Withstand voltage.....	11
5.10 Influence of water.....	11
5.11 Protection against dust.....	11
5.12 Endurance.....	11
5.13 Vibration.....	11
5.14 Shock resistance.....	11
5.15 Drop test.....	11
5.16 Temperature/humidity cycling.....	12
5.17 Salt spray.....	12
5.18 Chemical resistance.....	12
5.19 Leakage test of pneumatic connections.....	12
5.20 Functional test of protection covers.....	12
<b>Annex A (normative) EPI module — Dimensional characteristics</b> .....	<b>13</b>
<b>Annex B (normative) EPI module — Contact allocation</b> .....	<b>21</b>
<b>Annex C (normative) Mixed mode operation</b> .....	<b>23</b>
<b>Bibliography</b> .....	<b>27</b>

## Foreword

ISO (the International Organization for Standardization) is a worldwide federation of national standards bodies (ISO member bodies). The work of preparing International Standards is normally carried out through ISO technical committees. Each member body interested in a subject for which a technical committee has been established has the right to be represented on that committee. International organizations, governmental and non-governmental, in liaison with ISO, also take part in the work. ISO collaborates closely with the International Electrotechnical Commission (IEC) on all matters of electrotechnical standardization.

The procedures used to develop this document and those intended for its further maintenance are described in the ISO/IEC Directives, Part 1. In particular the different approval criteria needed for the different types of ISO documents should be noted. This document was drafted in accordance with the editorial rules of the ISO/IEC Directives, Part 2. [www.iso.org/directives](http://www.iso.org/directives)

Attention is drawn to the possibility that some of the elements of this document may be the subject of patent rights. ISO shall not be held responsible for identifying any or all such patent rights. Details of any patent rights identified during the development of the document will be in the Introduction and/or on the ISO list of patent declarations received. [www.iso.org/patents](http://www.iso.org/patents)

Any trade name used in this document is information given for the convenience of users and does not constitute an endorsement.

The committee responsible for this document is ISO/TC 22, *Road Vehicles*, Subcommittee SC 15, *Interchangeability of components of commercial vehicles and buses*.

ISO 13044 consists of the following parts, under the general title *Road vehicles — Fully automatic coupling systems 24 V (FACS) for heavy commercial vehicle combinations*:

- *Part 1: General requirements and definitions*
- *Part 2: 50 mm fifth wheel couplings — Electrical and pneumatic interface*

## Introduction

This International Standard specifies the integrated electrical and pneumatic connections of an automated fifth wheel coupling system for articulated vehicles and related components.

Fully Automated Coupling Systems improve safety and comfort of vehicle combinations.

a) Higher safety standards

reduction of operational accidents,

less injured drivers because no need for driver to stay in the dangerous zone between the towing and the towed vehicle while uncoupling.

b) Higher comfort level

Fully Automated Coupling Systems eliminate necessity to access the coupling,

higher comfort makes "Driver-Job" easier and safer,

new components create space for future extensions and potentials.

c) Cost reduction for end user

less inactive periods for the vehicle combination due to less damage and repair,

less repair and maintenance of cables and pipes.



# Road vehicles — Fully automatic coupling systems 24 V (FACS) for heavy commercial vehicle combinations —

## Part 2: 50 mm fifth wheel couplings — Electrical and pneumatic interface

### 1 Scope

This part of ISO 13044 specifies the mechanical, electrical/electronic and pneumatic characteristics of a fully automated fifth wheel coupling system to ensure interchangeability between a tractor vehicle and a coupled semi-trailer(s) with 24 V nominal supply voltage. The two vehicles together constitute an articulated vehicle.

This part of ISO 13044 also supports the smooth introduction of fully automated fifth wheel coupling systems in the market. It specifies features necessary for mixed mode operation; i.e. the combination of a fully automated coupling system (FACS) equipped tractor vehicle with a conventional semi-trailer, and vice versa, the combination of a conventional tractor vehicle with a FACS-equipped semi-trailer.

### 2 Normative references

The following documents, in whole or in part, are normatively referenced in this document and are indispensable for its application. For dated references, only the edition cited applies. For undated references, the latest edition of the referenced document (including any amendments) applies.

ISO 337, *Road vehicles — 50 semi-trailer fifth wheel coupling pin — Basic and mounting/interchangeability dimensions*

ISO 1726-1, *Road vehicles — Mechanical coupling between tractors and semi-trailers — Part 1: Interchangeability between tractors and semi-trailers for general cargo*

ISO 1726-2, *Road vehicles — Mechanical couplings between tractors and semi-trailers — Part 2: Interchangeability between low-coupling tractors and high-volume semi-trailers*

ISO 3833, *Road vehicles — Types — Terms and definitions*

ISO 3842, *Road vehicles — Fifth wheels — Interchangeability*

ISO 4009, *Commercial vehicles — Location of electrical and pneumatic connections between towing vehicles and trailers*

ISO 4091:2003, *Road vehicles — Connectors for the electrical connection of towing and towed vehicles — Definitions, tests and requirements*

ISO 7638-1:2003, *Road vehicles — Connectors for the electrical connection of towing and towed vehicles — Part 1: Connectors for braking systems and running gear of vehicles with 24 V nominal supply voltage*

ISO 11992 (all parts), *Road vehicles — Interchange of digital information on electrical connections between towing and towed vehicles*

ISO 12098:2004, *Road vehicles — Connectors for the electrical connection of towing and towed vehicles — 15-pole connector for vehicles with 24 V nominal supply voltage*



## ISO/FDIS 13044-2:2013(E)

ISO 16750-3:2012, *Road vehicles — Environmental conditions and testing for electrical and electronic equipment — Part 3: Mechanical loads*

ISO 16750-5:2003, *Road vehicles — Environmental conditions and testing for electrical and electronic equipment — Part 5: Chemical loads*

ISO 6150:1988, *Pneumatic fluid power — Cylindrical quick-action couplings for maximum working pressures of 10 bar, 16 bar and 25 bar (1 MPa, 1,6 Mpa, and 2,5 MPa) — Plug connecting dimensions, specifications, application guidelines and testing*

### 3 Terms and definitions

For the purposes of this part of ISO 13044, the terms and definitions given in ISO 13044-1 and the following terms and definitions apply.

#### 3.1 fully automated coupling system

##### FACS

coupling and uncoupling system where all operations, i.e. mechanical, electrical, pneumatic and applicable auxiliary functions, are performed automatically, enabling the coupling and uncoupling process to be completed without direct manual intervention

Note 1 to entry: As defined in ISO 13044-1:2012.

#### 3.2 electrical/electronic-pneumatic interface module

##### EPI module

component, combining all electrical/electronic and pneumatic connections in one mating unit, consisting of two complementary parts, the EPI plug module and the EPI socket module

##### 3.2.1 EPI plug module

part of the EPI module containing the electric male contacts, pneumatic male connections and the alignment pins. It is permanently attached to the kingpin side mounted on the semi-trailer

##### 3.2.2 EPI socket module

part of the EPI module containing the electric female contacts, pneumatic female connections and the alignment sockets. It is permanently attached to the fifth wheel which is mounted to the tractor vehicle

##### 3.2.3 semi-trailer

towed vehicle which is designed to be coupled to either a towing vehicle or to a dolly axle, and to impose a substantial vertical load either on the towing vehicle or on the dolly axle

##### 3.2.4 alignment device

device placed on the trailer-side, which makes contact to the 5th wheel throat during the coupling process and centres the EPI plug relative to the EPI socket

### 4 Requirements

#### 4.1 General

In order to guarantee best functionality, comfort and safety, the use of FACS is recommended in combination with spring-brake equipped semi-trailers only. FACS does not exonerate the driver from ensuring the semi-trailer is correctly parked before coupling or uncoupling.

In order to guarantee best functionality, comfort and safety, the use of FACS is recommended in combination with adjustable air-suspension on the rear axle equipped trucks only.

In the case of coupling systems that are not fully automatic, but utilize an automatic electro-pneumatic interface, this interface shall comply with the requirements specified within this International Standard.

## 4.2 Tractor and semi-trailer

In order to ensure interchangeability between tractor vehicles and semi-trailers, the requirements of ISO 3842 and ISO 1726-1 or ISO 1726-2 shall be met for vehicles to be equipped with FACS.

## 4.3 Mechanical interface, Manual operation

Fifth wheels installed on FACS-equipped tractor vehicles shall comply with the requirements of ISO 3842. Fifth wheel coupling pins (king pins) installed on FACS-equipped semi-trailers shall comply with the requirements of ISO 337. In the event of a failure of the remote control it shall be possible, in an emergency, to open the coupling in at least one other way. If this requires the use of a tool then this shall be included in the vehicle's tool kit. Any manual operation shall not lead to any damages or malfunction of the system components.

**NOTE** For fifth wheel versions with a throat angle other than 40° (e.g. 52°) optional versions would be allowed under the condition that the alignment device (Figure 2, key 2 or Figure 1, key 2) would use a corresponding angle. In this case the interchangeability will only be ensured within the individual version.

## 4.4 EPI module

**4.4.1** EPI plug modules and EPI socket modules in accordance with this Standard shall provide the following electrical connections with 24 V nominal supply voltage:

- 7 poles for the electrical connection of the braking systems and running gear (incl. 2 poles for the CAN based communication compliant to ISO 11992-1 and -2);
- 23 poles for the electrical connection of equipment other than braking systems and running gear (incl. 2 poles for the CAN-based communication compliant to ISO 11992-1 and -3);

The dimensional characteristics and location of the EPI module shall be in accordance with the specifications of [Annex A](#). Number, location and functionality shall be in accordance with the specifications of [Annex B](#). Electrical contacts shall only be used as specified.

**CAUTION — Using the electrical contacts for non-specified purposes (including ground) may cause damage to equipment. Any deviation from the contact allocation specified in Table 1 is not allowed. However, depending on legislation and customer demand, only some of the 30 electrical contacts may be required.**

**4.4.2** EPI plug modules and EPI socket modules in accordance with this International Standard shall provide connections for the following two pneumatic braking lines:

- one control line;
- one supply line;

The dimensional characteristics of the pneumatic connections shall be in accordance with the specifications of [Annex A](#).

## 4.5 Mating of the two EPI parts

The mating of the EPI plug module and the EPI socket module shall be connected automatically during the coupling process as illustrated in [Annex A](#), Figure A.1.

4.6 Guiding and alignment

4.6.1 General

The guiding and alignment of the EPI module shall be made by a rigid alignment pin in the middle plus two outer pins, which are preferably “self-aligning” designed to provide low forces during EPI mating; see Annex A, Figure A.5. Each of the outer alignment pins shall have sufficient elasticity to permit a maximum of 2 mm deflection in any direction relative to the longitudinal axis of the central alignment pin. The deflection force shall be in the range from 50 N to 200 N.

The central alignment pin shall have the ability to align both EPI parts within a range  $\pm 5$  mm in both horizontal and vertical directions. The two outer pins shall ensure the parallel orientation of both EPI parts for connection alignment.

The positional tolerance between the contact surface of the alignment device and the fifth wheel shall be a maximum of  $\pm 2$  mm, according to Figure 1.

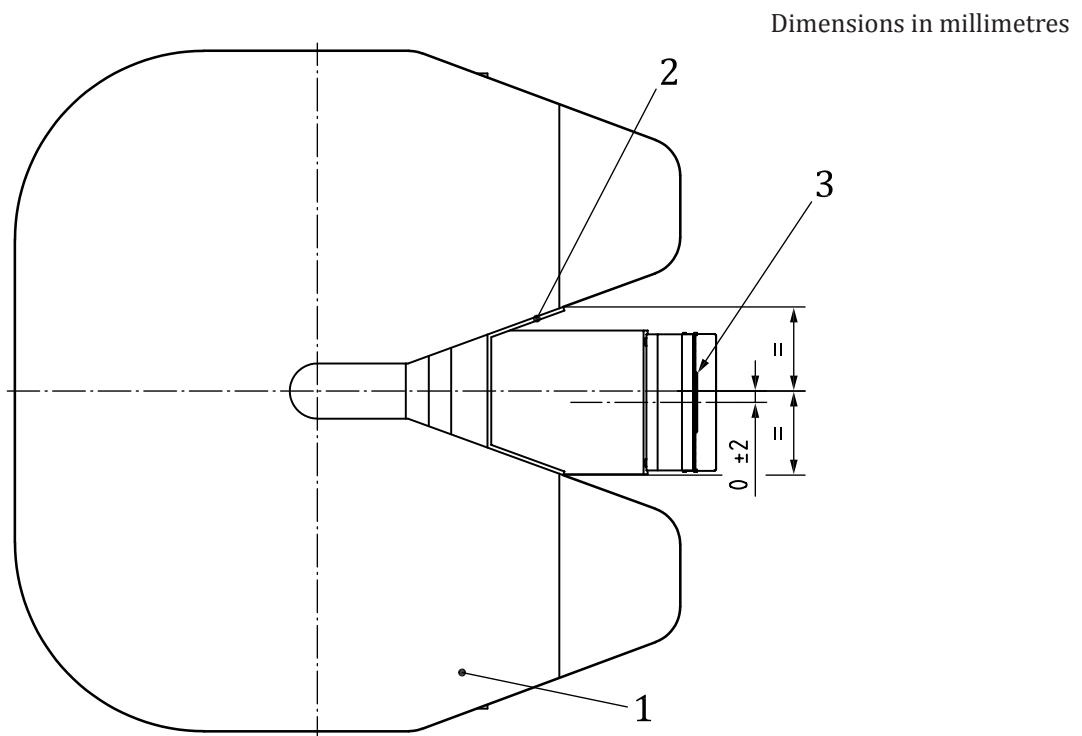

Key

- 1 Fifth wheel
- 2 Alignment device (movable in length direction, shown in contact position, see Figure 2)
- 3 EPI central alignment socket

Figure 1 — EPI female module positioning tolerance (displaced shown)

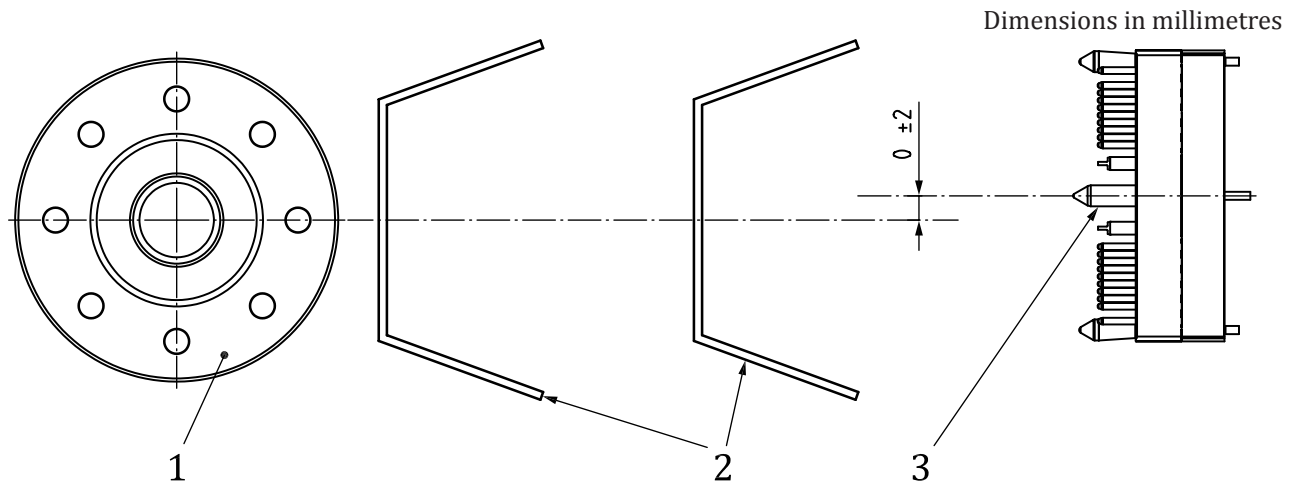
**Key**

- 1 King pin
- 2 Alignment device (movable in length direction, shown in two positions)
- 3 EPI central alignment pin

**Figure 2 — EPI male module positioning tolerance (displaced shown)**

#### 4.6.2 Installation requirements of tractor-mounted EPI module

##### 4.6.2.1 Linear degree of freedom in the longitudinal direction of alignment pin:

**4.6.2.1.1 No actuator:** Displaceable from 0 to a minimum of 30 mm [s2, as shown in Figure A.2 C)], preloaded with a force between 250 N to 500 N (as both pneumatic lines are under pressure) when uncoupled, achieved by means of either elastic elements or other stored energy. With the FACS coupled the EPI socket module will be pushed forward by  $s_1 = 15$  mm [see Figure A.2 B)] which is the nominal position. In the coupled position, a movement as described above shall be possible, without the EPI modules being disconnected or damaged.

**4.6.2.1.2 With actuator:** The actuator shall move the EPI socket by at least the range described in [4.6.2.1.1](#).

**4.6.2.2** Linear degree of freedom in the lateral direction: essentially fixed.

**4.6.2.3** Linear degree of freedom in the vertical direction: essentially fixed.

**4.6.2.4** Rotational degree of freedom around the longitudinal axis of EPI tractor alignment socket: essentially fixed.

**4.6.2.5** Rotational degree of freedom around the lateral articulation axis: from horizontal to a minimum of  $12^\circ$  [EPI module upwards, see Figure A.2 b)].

**4.6.2.6** Rotational degree of freedom around the vertical axis: essentially fixed.

#### 4.6.3 Installation requirements of semi-trailer-mounted EPI module

**4.6.3.1** Linear degree of freedom in the longitudinal direction of the alignment pin: fixed.

**4.6.3.2** Linear degree of freedom in the lateral direction: essentially fixed.

**4.6.3.3** Linear degree of freedom in the vertical direction: essentially fixed.

**4.6.3.4** Rotational degree of freedom around the longitudinal axis of the truck alignment pin:  $\pm 2^\circ$ .

**4.6.3.5** Rotational degree of freedom around the lateral axis:  $\pm 2^\circ$ .

**4.6.3.6** Rotational degree of freedom around the vertical axis:  $\pm 100^\circ$  around king pin axis,  $\pm 2^\circ$  around vertical axis through EPI-Module.

#### **4.6.4 Perpendicular degree of freedom of contacts**

Each electric male contact shall be floating and shall align to the datum position when EPI plug and socket are engaged according to ISO 12098:2004, 4.1 and ISO 7638-1:2003, 4.1.

Each pneumatic male contact shall be floating to allow a degree of freedom of a minimum of 0,5 mm perpendicular to the main alignment pin axis and with a minimum of  $\pm 0,5^\circ$  axis deviation.

#### **4.6.5 Pneumatic valves in EPI socket module**

Both pneumatic sockets have to be airtight when disconnected. These sockets shall be opened by the pneumatic plugs [see A.5 a)]. The sockets shall be fully open a minimum of 3 mm before EPI modules are mated. To compensate tolerances, the sockets shall stay fully open a minimum of 3 mm after the EPI modules are mated.

The minimum flow diameter of the pneumatic socket when fully open shall not be less than the internal diameter of the EPI pneumatic plug, which is strongly recommended to have a maximum inner diameter of 6 mm (see NOTE below).

NOTE Reductions in the internal diameter may increase the response time when tested in accordance with the procedure defined in regulations like e.g. Annex 6 to ECE Regulation 13.

### **4.7 Encapsulation and protection**

#### **4.7.1 General**

In order to guarantee interchangeability, protection covers of the EPI modules shall be located in defined positions having devices and activation points which are determined as follows.

##### **4.7.1.1 Protection cover on the EPI socket module**

See [Annex A](#), Figures A.6 – A.8.

##### **4.7.1.2 Protection cover on the EPI plug module**

See [Annex A](#), Figures A.9.

#### **4.7.2 EPI plug module protection cover actuation**

The protection cover on the EPI plug module:

- Shall open early enough to lift the EPI socket module during the coupling process;
- Shall try to close before the kingpin reaches the coupled position;
- Shall not cause damage to any part while trying to close;
- Shall close completely in case there is no EPI socket module.

### 4.7.3 Gasket between plug and socket

In order to ensure a correct seal when connected, a gasket shall be installed between plug and socket on the contact surface of the EPI socket module.

See [Annex A](#), Figure A.1.

## 4.8 Automation of landing legs

Automated landing legs shall be power driven without necessarily being able to lift the semi-trailer.

The following parameters shall be applied when using electrical operation:

Nominal voltage: 24V;

Current limitation: 15A;

Polarity: contact L12 in Table B.1 is positive while running landing gear up;

Contact L13 in Table B.1 is positive while running landing gear down;

Operating time: minimum 20s, maximum 90s;

As the landing legs reach the end position, the current shall be cut off on the truck side within 2 s as long as 18 A are exceeded.

## 4.9 ISO 11992 Cable length

Part 1 of ISO 11992 specifies the respective maximum lengths of the cables allocated to the towing vehicle, trailer and interface connection. In the case of a FACS equipped towing vehicle or trailer the length associated with the interface cable is not appropriate therefore the length 7m specified for this interface may be allocated to the FACS elements of the towing vehicle and trailer as described in this paragraph. [Figure 3](#) below defines the electrical installation associated with data communications for braking and is specified as follows:

- Towing vehicle: The combined length of a + b shall be a maximum of 21 m;
- Semi-trailer: The combined length of c + d shall be a maximum of 19 m.

**IMPORTANT — Using the above cable lengths ensures that the overall length of cable available to connect from the tractors ABS/EBS ECU to the trailer ABS/EBS ECU as specified in Part 1 of ISO 11992 is not exceeded.**

NOTE For parameters a, b, c and d see [Figure 3](#).

## 4.10 Mixed mode operation

For example provisions, see [Annex C](#).

The design of this electrical circuit shall be configured in a way that a point- to-point connection is ensured as required by ISO 11992.

# 5 Tests and specific requirements

## 5.1 General

Tests and requirements for EPI modules in accordance with this Standard are specified in the following clauses. The test sequence to be followed shall be as given in Table 1. The test sequence shall be carried out in the order of the running numbers listed in Table 1 under the particular sample group. A test sequence shall be continued only if the sample meets the applicable requirements.

**Table 1 — Test sequence**

Item	Test title	Sample group					
		A	B	C	D	E	F
5.2	Visual examination	1, 5, 9	1, 11	1, 7, 12	1, 6	1, 7, 9	1, 8
5.3	Dimensional check	2					
5.4	Connection and disconnection	3	2	2		2	
5.5	Locking device operating test	4, 8	3, 10	3, 10			
5.6	Current carrying capacity				3		
5.7	Connection resistance		4, 7	4, 9	2, 5	6	2, 6
5.8	Current cycling				4		
5.9	Withstand voltage		5, 9	8			3, 7
5.10	Influence of water		8	11			
5.11	Protection against dust					5	
5.12	Endurance					4	
5.13	Vibration					3	4
5.14	Shock resistance	6					
5.15	Drop test	7					5
5.16	Temperature/humidity cycling		6				
5.17	Salt spray			5			
5.18	Chemical resistance			6			
5.19	Pneumatic connection leakage test					8	
5.20	Protection cover test	see <a href="#">5.12</a>					

## 5.2 Visual examination

Testing and requirements shall be in compliance with ISO 4091:2003, 5.1.

## 5.3 Dimensional check

Testing and requirements shall be in compliance with ISO 4091:2003, 5.2.

## 5.4 Connection and disconnection

All load-bearing mechanical components shall be able to withstand a minimum force of 1 500 N in the connecting direction.

All load-bearing mechanical components shall be able to withstand a minimum force of 1 500 N in the disconnecting direction.

In case the connector is assisted by an actuator, the force which acts on the connector shall be between 250 N and 500 N.

The peak force of the electrical female contact connecting with the corresponding electrical male contact in MMC (Maximum Material Condition) [see A.5 d)] shall be less than 5 N.

The peak force of the pneumatic female contact connecting with the corresponding pneumatic male contact in MMC (Maximum Material Condition) [see A.5 b)] shall be less than 20 N, the sliding force shall be less than 5N. These measurements shall be done without pneumatic pressure.

## 5.5 Locking device operation

### 5.5.1 Application

The following applies to connectors not equipped with a distinct locking device, but secured by means of the interlock between the 5<sup>th</sup> wheel and king pin.

### 5.5.2 Requirements

In order to compensate for play and tolerances, the sum of the forces acting to hold the plug and socket together shall not be less than the sum of the maximum forces defined in 5.4 throughout the connector's entire range of motion and, if forces are created by air pressure, entire ranges of pressure.

Pressure ranges in operation are:

- supply line from 6 bar to 12 bar;
- control line from 0 bar to 12 bar.

## 5.6 Current carrying capacity

Testing and requirements shall be in compliance with ISO 4091:2003, 5.8.

## 5.7 Connection resistance (voltage drop), cable capacitance and pneumatics

Testing and requirements shall be in compliance with ISO 4091:2003, 5.9.

The total cable capacitance of the data lines (b + c) 7 m shall be a maximum of 350 pF, corresponding to an average capacitance of 50 pF/m (in compliance with ISO 4141-1:2005, 6.3), for the additional FACS harness.

NOTE The example in [Figure 4](#) for the pneumatic tubing is provided to illustrate the complete system configuration.

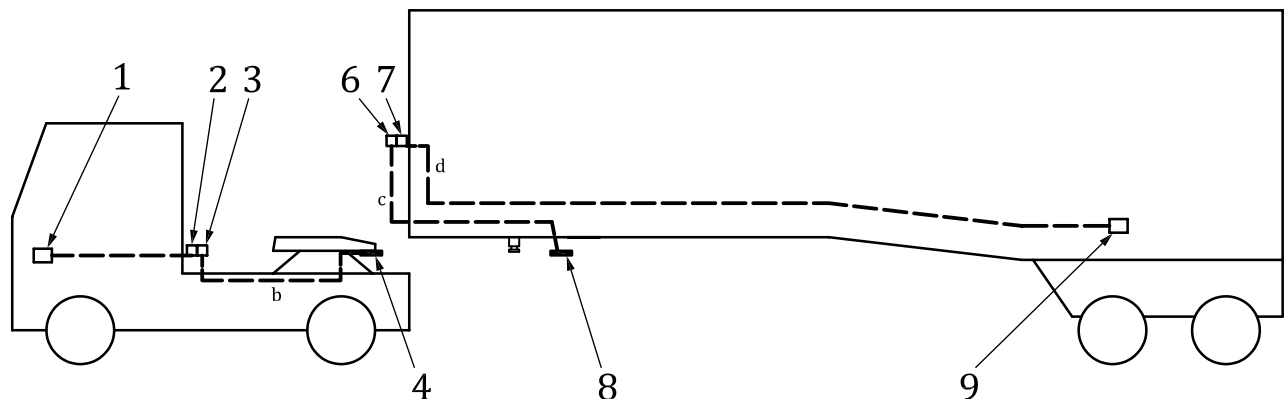

### Key

- |   |   |                           |                           |
|---|---|---------------------------|---------------------------|
| 1 | ISO 11992-2 or ISO 11992-3 node in tractor, e.g. ECUa | Cable harness from 1 to 2 |                           |
|   | ABS/EBS or databus device acc. ISO 12098              |                           |                           |
| 4 | EPI socket module                                     | b                         | Cable harness from 3 to 4 |
| 8 | Semi-trailer-sided EPI                                | c                         | Cable harness from 8 to 6 |
| 9 | ISO 11992-2 or ISO 11992-3 node in semi-trailer,      | d                         | Cable harness from 7 to 9 |
|   | e.g. ECU ABS/EBS or databus device acc. ISO 12098     |                           |                           |

**Figure 3 — Example of an electrical wiring diagram of FACS equipped tractor and semi-trailer**

NOTE Connectors 2, 3, 6 and 7 enable either mixed mode or emergency operations.



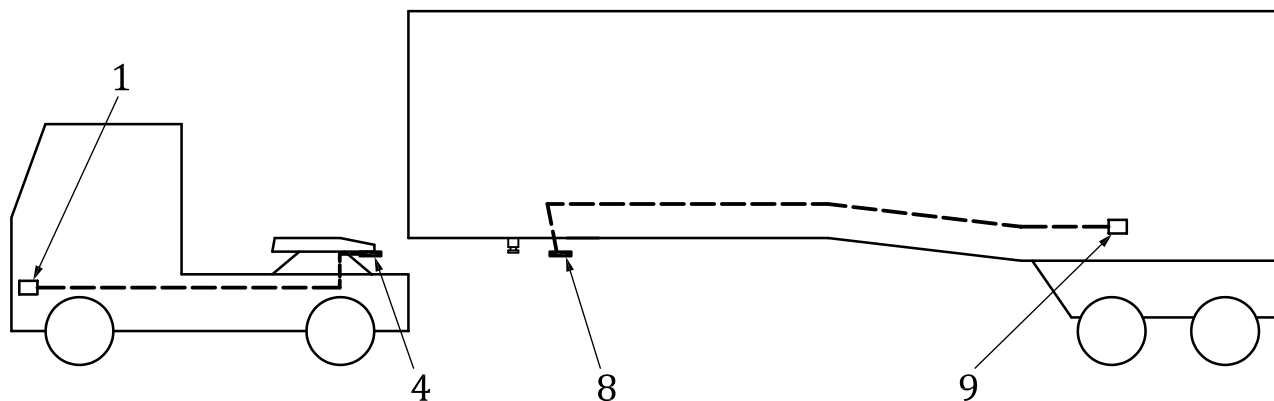
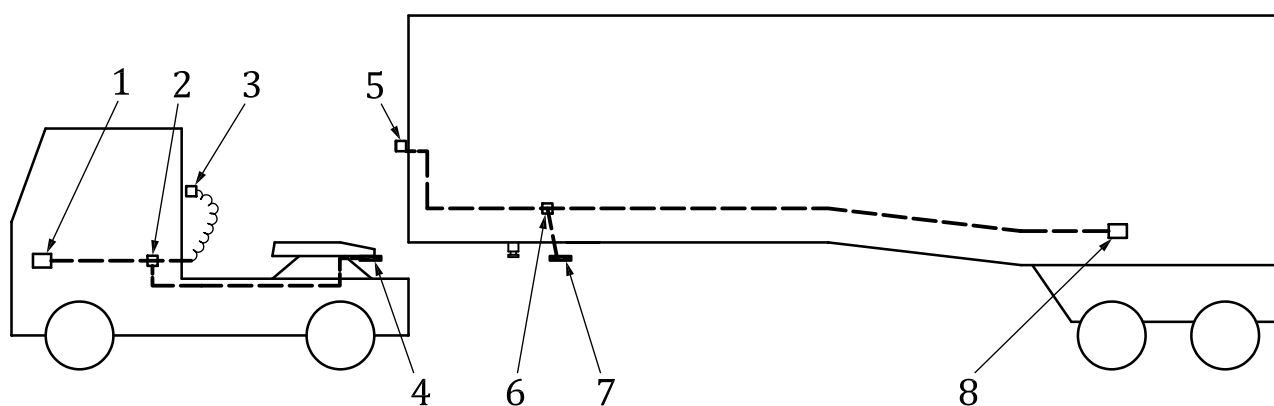

Figure 3 — a — Example of electrical wiring diagram in non-mixed mode



**Key**

- 1 Semi-trailer control valve mounted on tractor
- 4 Tractor-sided EPI
- 8 Semi-trailer-sided EPI
- 9 Semi-trailer regulating valve(s)

Figure 4 — Example of pneumatic tubing diagram of FACS equipped tractor and semi-trailer

NOTE Connectors 2, 3, 6 and 7 enable either mixed mode or emergency operations.

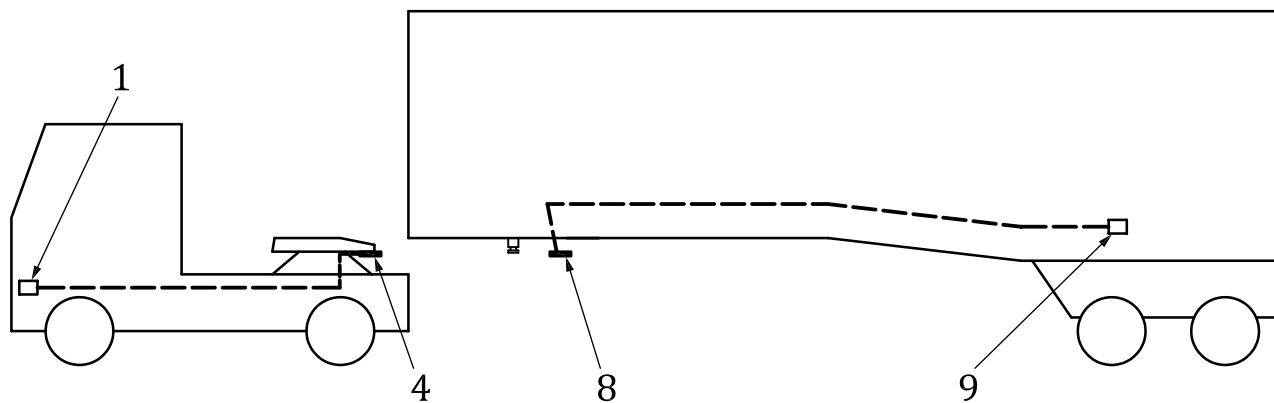

Figure 4 — a — Example of pneumatic tubing diagram in non-mixed mode

### 5.8 Current cycling

Testing and requirements shall be in compliance with ISO 4091:2003, 5.10.

### 5.9 Withstand voltage

Testing and requirements shall be in compliance with ISO 4091:2003, 5.11.

### 5.10 Influence of water

Testing and requirements shall be in compliance with ISO 4091:2003, 5.12.

### 5.11 Protection against dust

Testing and requirements shall be in compliance with ISO 4091:2003, 5.14.

### 5.12 Endurance

EPI modules shall conform to the endurance test conditions specified in ISO 4091, except that for the number of test cycles the following 3-step approach shall be applied:

- 9 000 cycles at a speed of 0,2 m/s ( $\pm 10\%$ );
- cycles at a speed of 0,2 m/s ( $\pm 10\%$ ) under 80 % of the max allowed misalignment;
- 500 cycles at a speed of 0,6 m/s ( $\pm 10\%$ ). The test shall include the encapsulation and protection devices described in [4.6](#).

### 5.13 Vibration

Testing and requirements shall be in compliance with ISO 16750-3:2012, 4.1.2.7.

Vibrational tests shall be achieved in orientation of use. If not actuator-equipped pre-load according [4.6.2.1.1](#) shall be reduced to achieve  $s1$  5 mm; all other dimensions shall be nominal. The EPIs shall be tested while being mounted in their suspension assemblies. These suspensions shall include all the parts from tractor EPI to the elastic elements and axles needed to fulfil 4.6.2 respectively semi-trailer EPI and elastic elements and axles to fulfil 4.6.3.

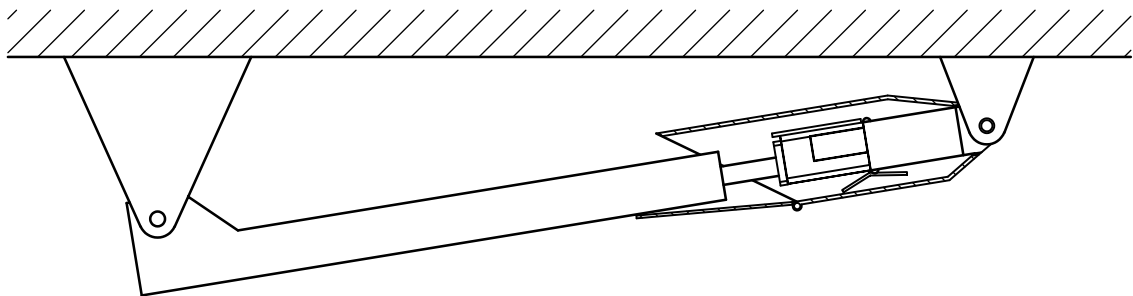

Figure 5 — Vibrational test

### 5.14 Shock resistance

Testing and requirements shall be in compliance with ISO 16750-3:2012, 4.2.2.

### 5.15 Drop test

Testing and requirements shall be in compliance with ISO 16750-3:2012, 4.3.

### **5.16 Temperature/humidity cycling**

Testing and requirements shall be in compliance with ISO 4091:2003, 5.18.

### **5.17 Salt spray**

The following specifications shall be taken into account:

- a) EPI modules disconnected, with flaps protection covers closed: Test conditions according to ISO 4091 with 96 h test time.
- b) EPI plug and socket module coupled: Test conditions according to ISO 4091, however, with 300 h test time.

### **5.18 Chemical resistance**

The following chemical agents shall be selected for testing:

- lubricating oil;
- diesel fuel;
- grease;
- alkaline cleaning agent;
- neutral cleaning agent;
- white spirit;
- acid cleaning agent.

For the composition of these chemical agents, see ISO 16750-5. Testing conditions, particularly the test temperatures and test duration, shall be in compliance with ISO 16750-5.

### **5.19 Leakage test of pneumatic connections**

Testing shall be in compliance with ISO 6150:1988 series A. However, the number of test cycles shall be 10.000.

Leakage rates shall be determined after 5 000 and 10 000 cycles with performance according to ISO 6150, 6.10.

### **5.20 Functional test of protection covers**

The testing of the protection cover functionality shall be included in the endurance test according to [5.12](#).

## Annex A (normative)

### EPI module — Dimensional characteristics

#### A.1 Operation sequence

The operation sequence in FACS mode shall be as specified in Figure A.1

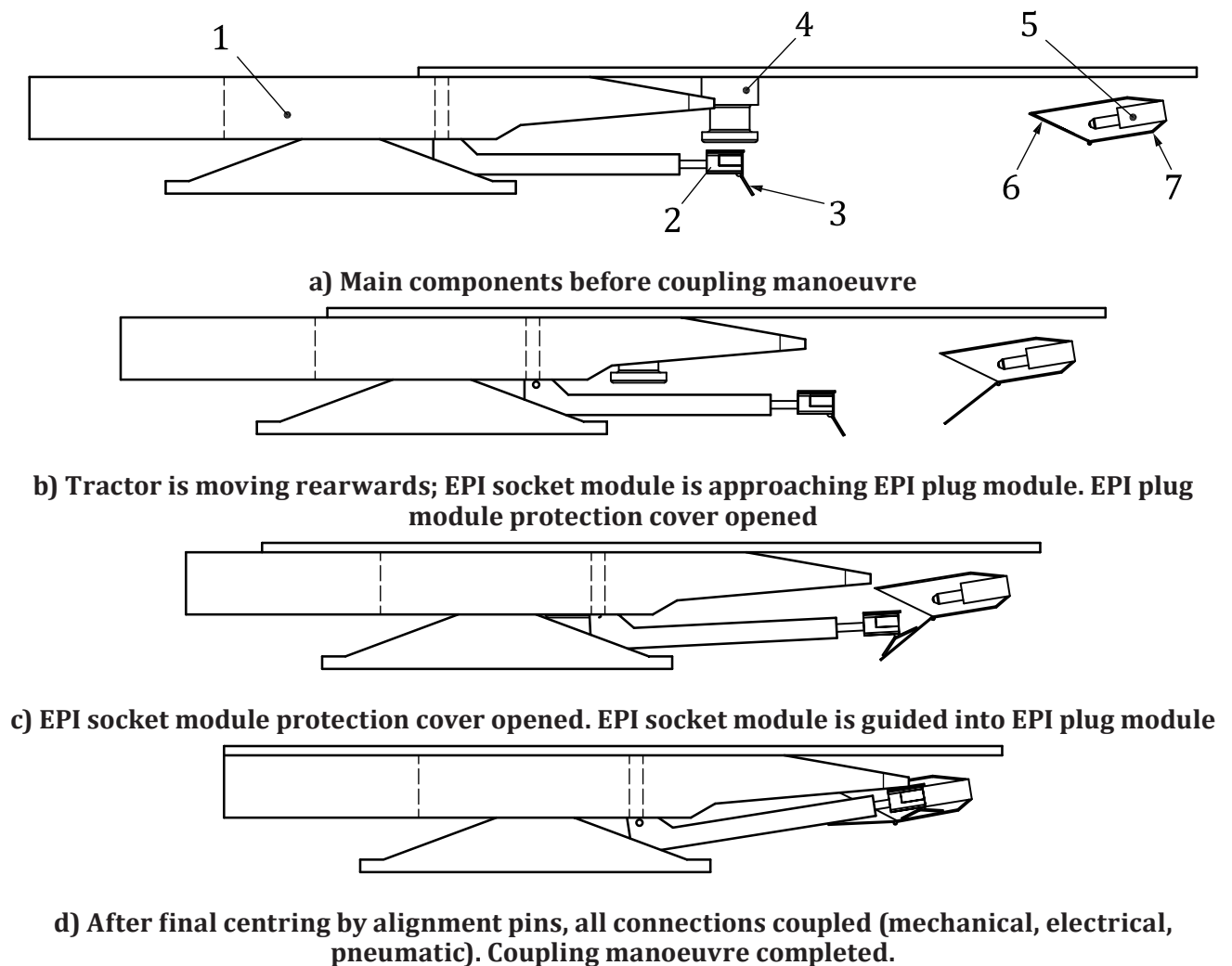

#### Key

- |   |                                    |   |                                  |
|---|------------------------------------|---|----------------------------------|
| 1 | Fifth wheel                        | 5 | EPI plug module                  |
| 2 | EPI socket module                  | 6 | EPI plug module protection cover |
| 3 | EPI socket module protection cover | 7 | EPI plug module housing          |
| 4 | King pin                           |   |                                  |

**Figure A.1 — Operation sequence in FACS mode**

**A.2 EPI characteristics — Positions**

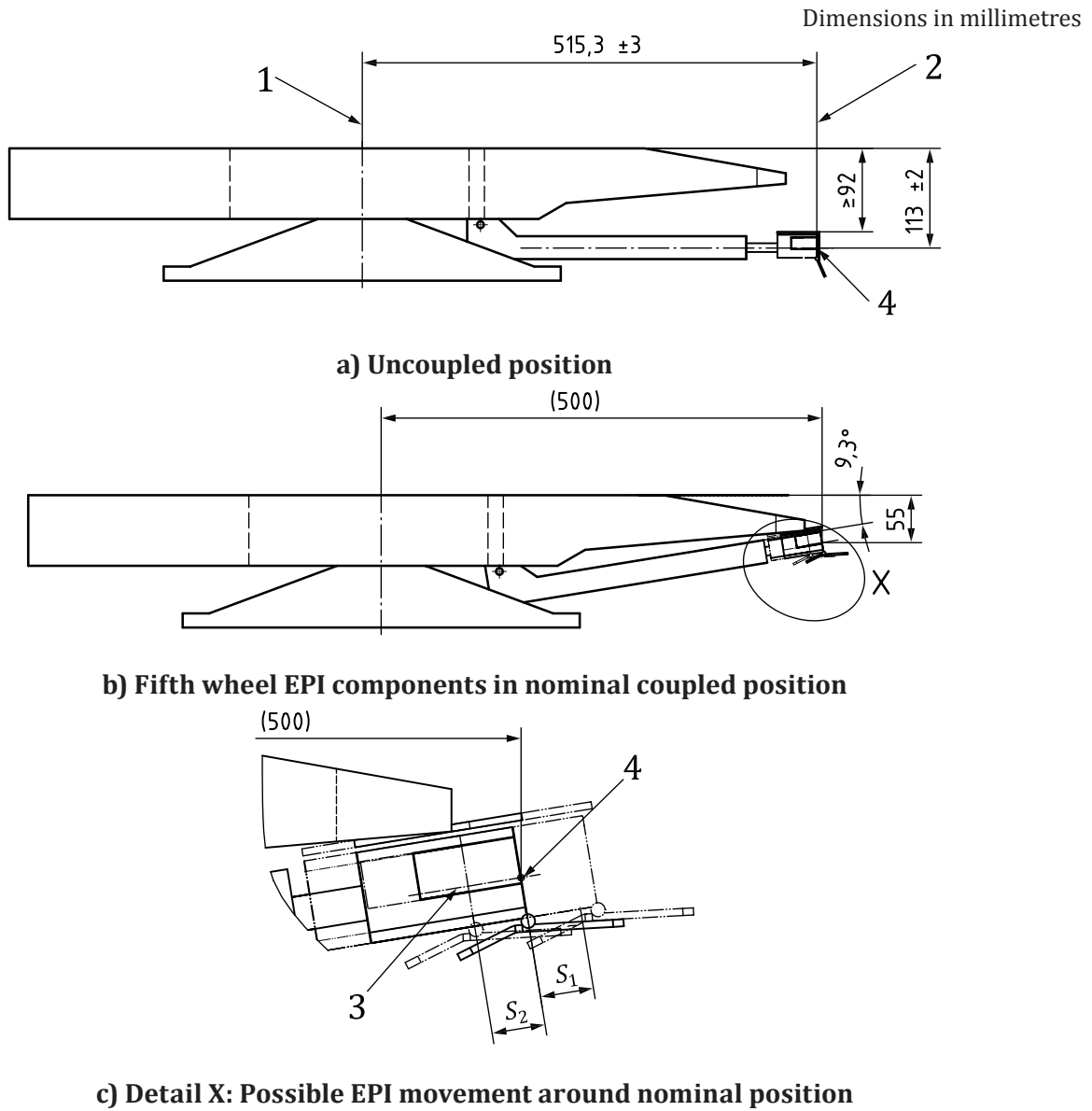

**Key**

- |   |   |  |
|---|---|--|
| 1 | Axis of the fifth wheel (coincides with the axis of the 5 kingpin when coupled) | Lateral articulation axis (figure to be updated) |
| 2 | Front face of the EPI socket module   | $S_1$ 15mm                                       |
| 3 | Axis of central alignment pin socket boring                                     | $S_2$ 15mm                                       |
| 4 | Central EPI operating point: intersection of front face (2) and axis(3)         |  |

**Figure A.2 — Position of the EPI socket module on the fifth wheel**

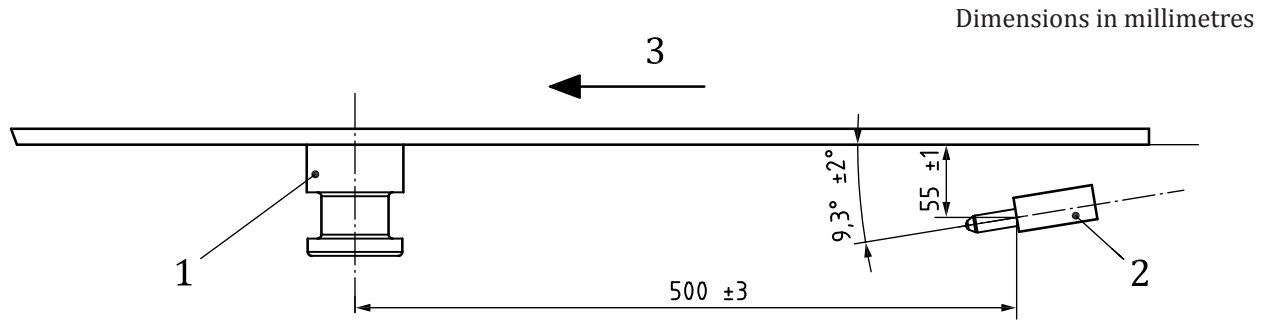

**Key**

- 1 Kingpin
- 2 EPI semi-trailer
- 3 Forward direction

**Figure A.3 — Position of the EPI plug module**

**A.3 EPI characteristics — Dimensions**

**A.3.1 EPI socket module**

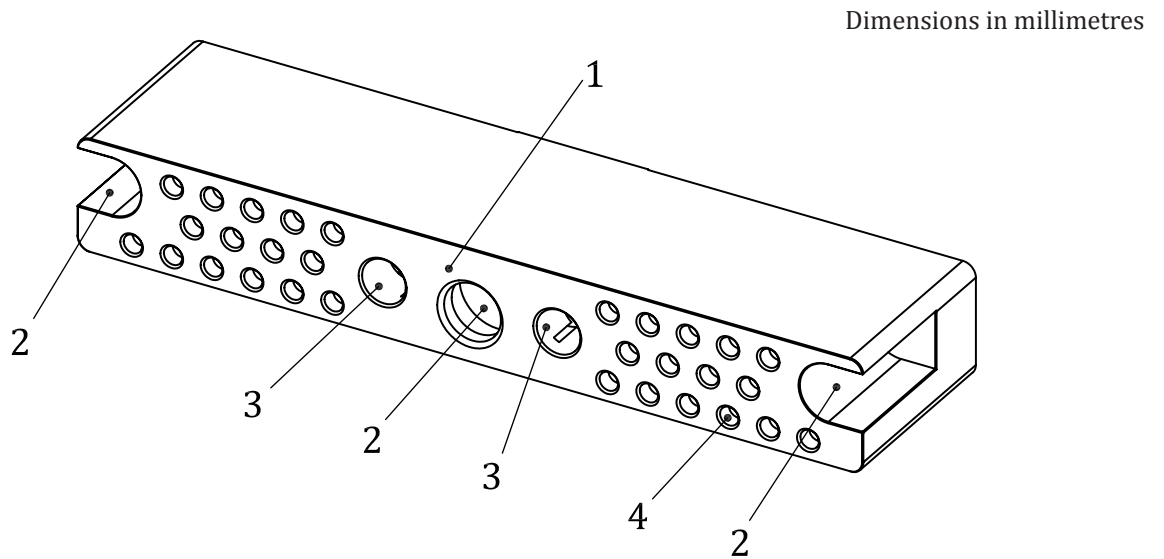

**a) — Isometric view**

**Key**

- 1 Gasket
- 2 Alignment socket
- 3 Pneumatic socket
- 4 Electric sockets (30x)

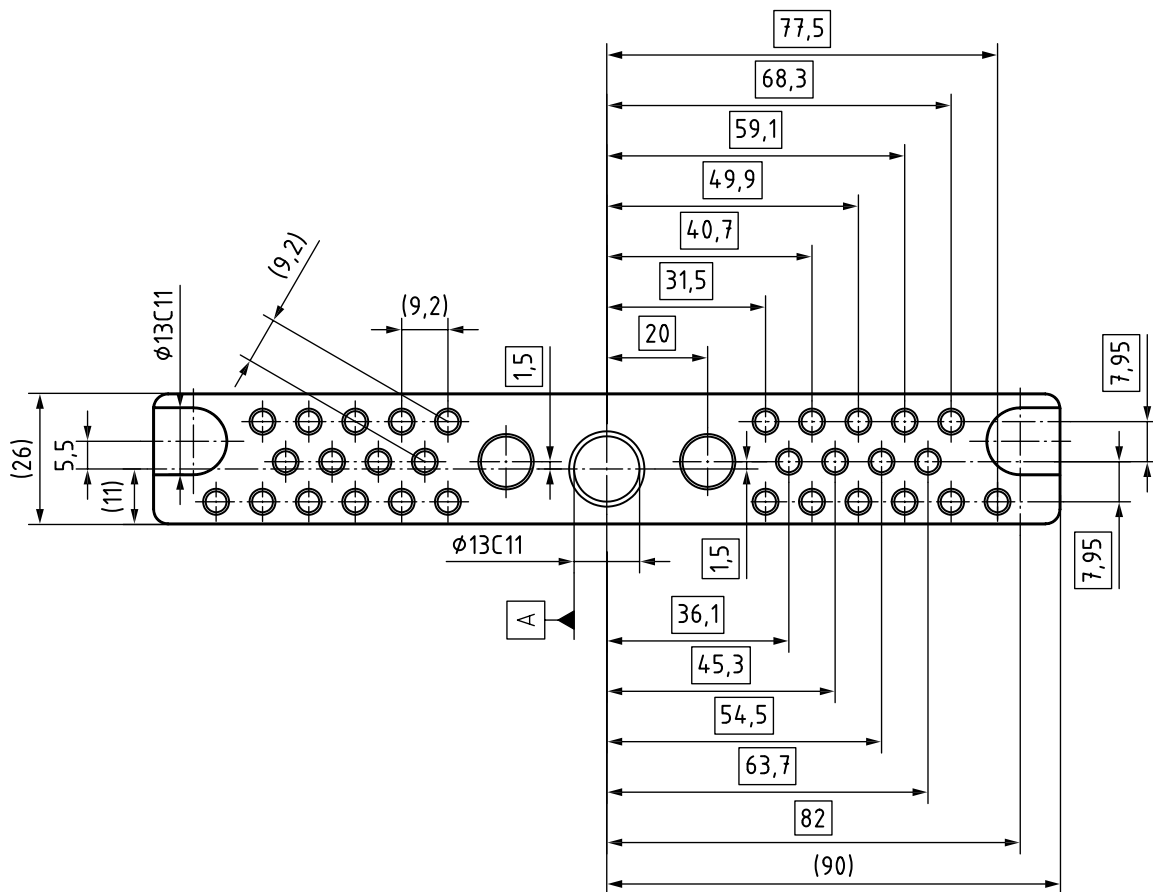

**b) Dimensions — Socket front view**

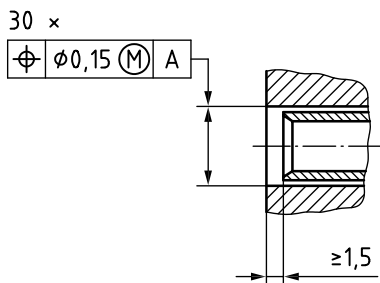

**c) Dimensions of female contacts (taken from ISO 7638-1)**

**Figure A.4 — EPI socket module**

Dimensions and tolerances shall be valid for all 30 electric and 2 pneumatic female contacts.

A.3.2 EPI plug module

Dimensions in millimetres

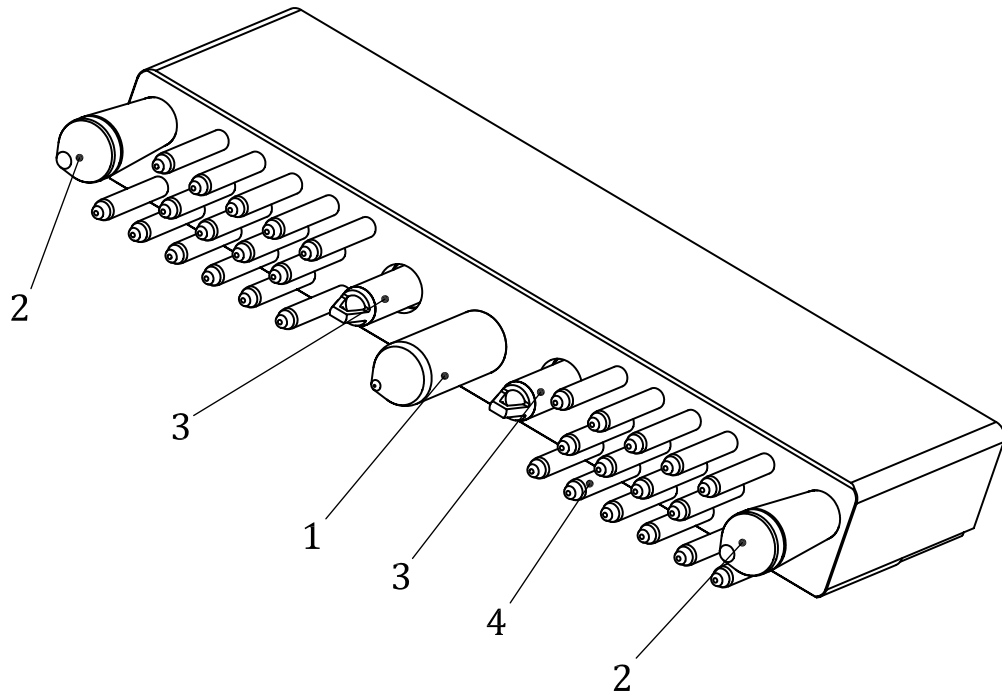

a) Isometric view

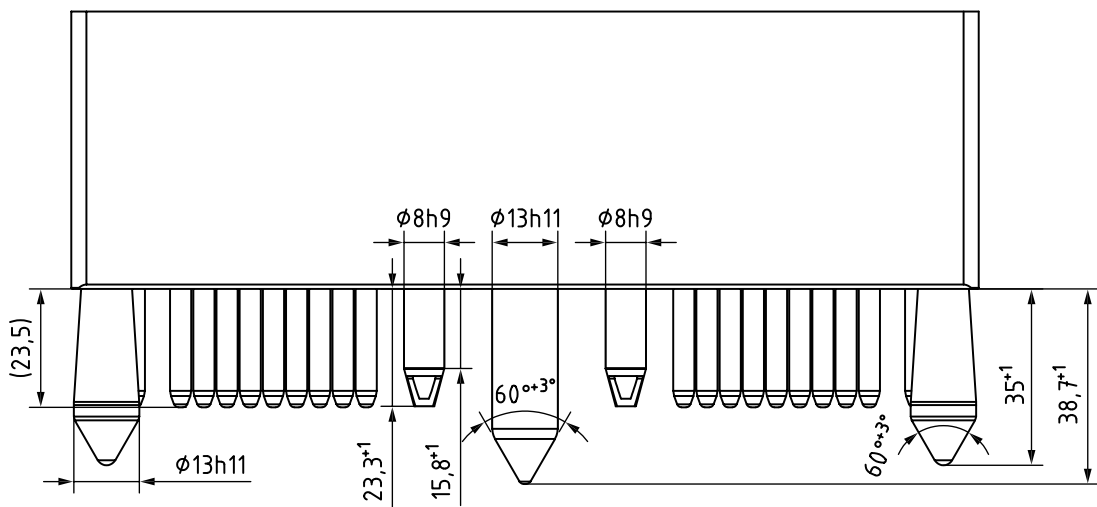

b) Dimensions — Top view



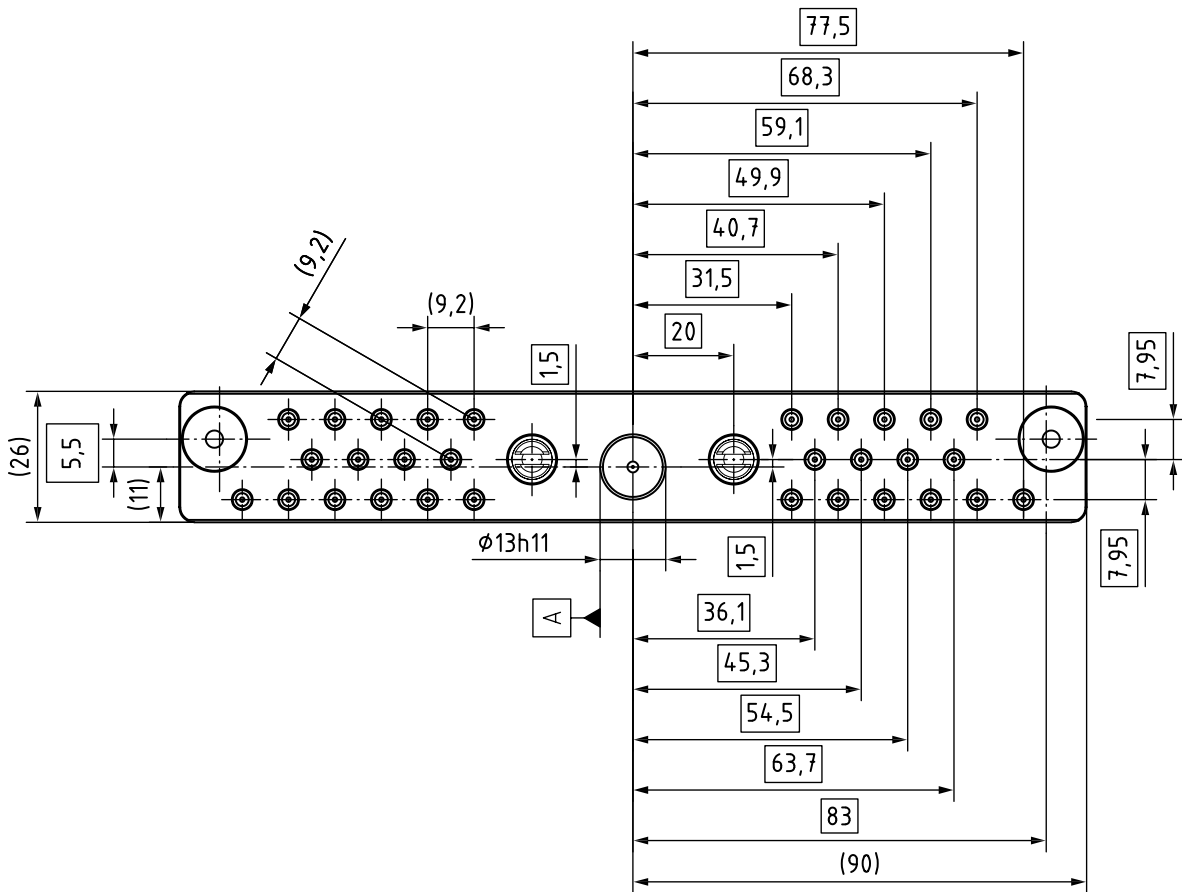

c) Dimensions — Front view

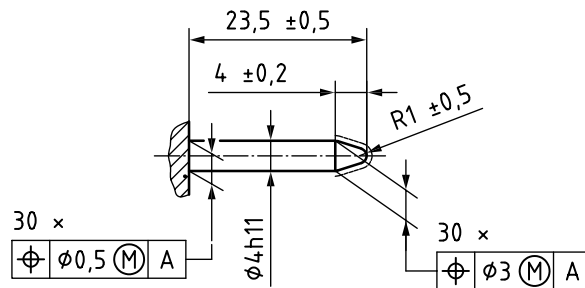

d) Dimensions of male contacts (taken from ISO 7638-1)

**Key**

- 1 Central alignment pin, rigid
- 2 Flexible outer alignment pins (2x)
- 3 Pneumatic male connections (2x)
- 4 Electric male contacts (30x)

**Figure A.5 — EPI plug module**

Dimensions and tolerances shall be valid for all 30 electric and 2 pneumatic male contacts.

Dimensions in millimetres

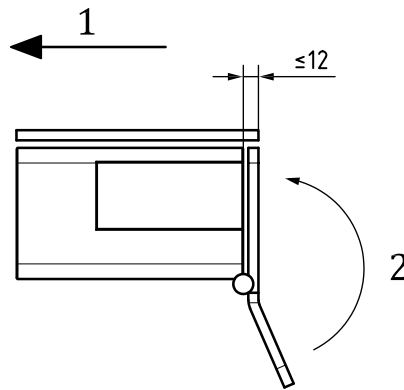

**Key**

- 1 Driving direction
- 2 Shutting torque min. 0,05 Nm, max. 0,2 Nm as cover is closed

**Figure A.6 — EPI socket module protection — Closed position (left side view)**

Dimensions in millimetres

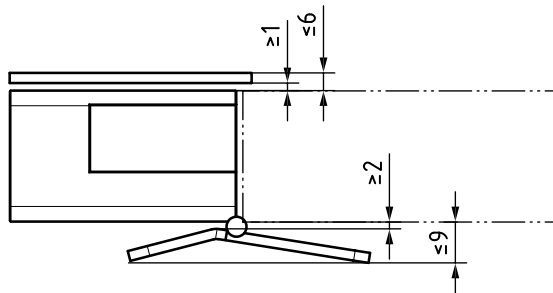

**Figure A.7 — EPI socket module protection - Opened position**

Dimensions in millimetres

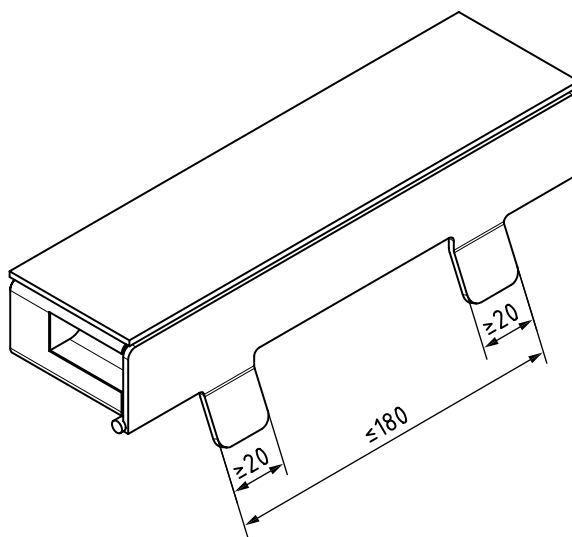

**Figure A.8 — EPI socket module protection activation tabs - Socket front view**

Dimensions in millimetres

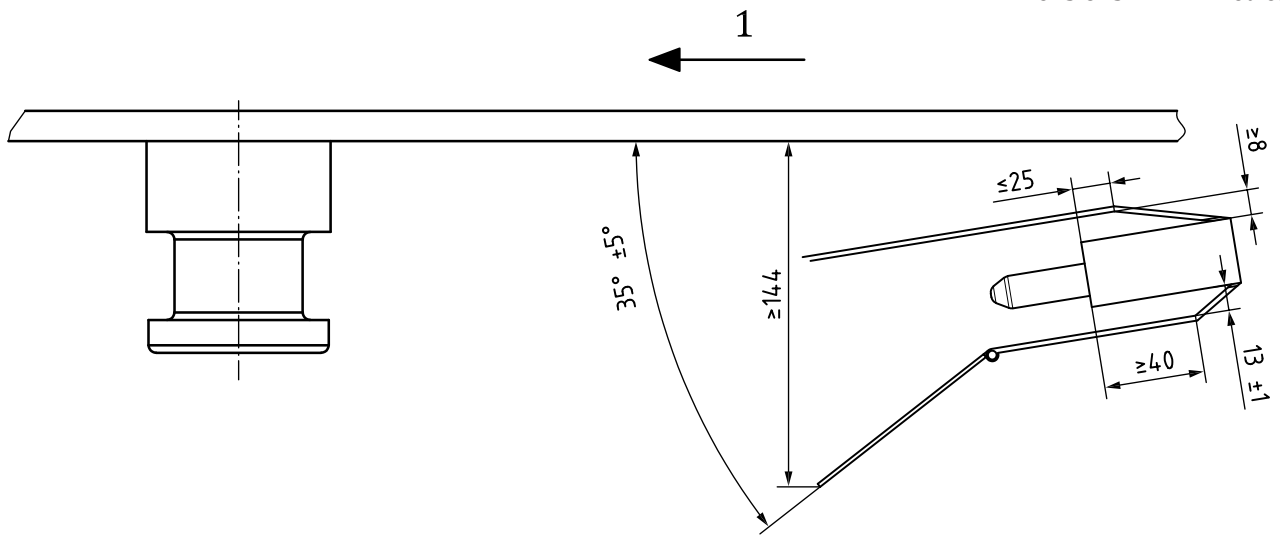

**Key**

1 Driving direction

**Figure A.9 — EPI module protection - Opened position, dimensions**

## Annex B (normative)

### EPI module — Contact allocation

The electric and pneumatic contacts shall be allocated as specified in Table B.1.

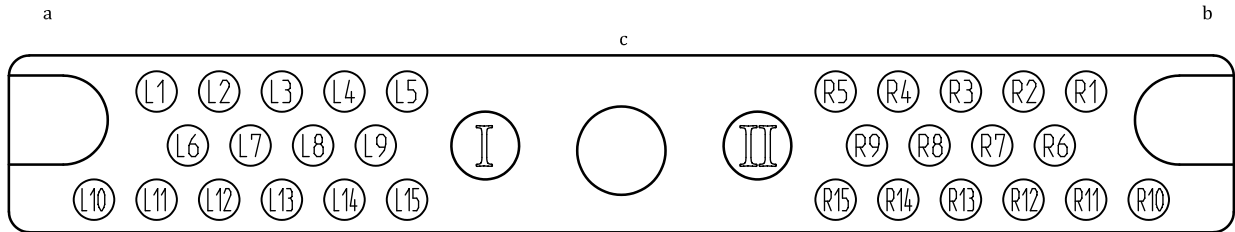

#### Key

- a Left side of tractor
- b Right side of tractor
- c Top

**Figure B.1 — Contact allocation — Rear view of socket, tractor side**

NOTE For detailed allocation see Table B.1.

**Table B.1 — Electric and pneumatic contact allocation**

Contact No.	<sup>a</sup> min mm <sup>2</sup>	Reference	Function
L 1	4	ISO 7638-1 Pin 1	ABS/EBS plus electrovalve
L 2	1,5	ISO 7638-1 Pin 2	ABS/EBS plus electronics
L 3	1,5	ISO 7638-1 Pin 3	ABS/EBS minus electronics
L 4	4	ISO 7638-1 Pin 4	ABS/EBS minus electrovalve
L 5	1,5	ISO 7638-1 Pin 5	ABS/EBS warning device
L 6	1,5	ISO 7638-1 Pin 6	ABS/EBS CAN High according to ISO 11992-1 and 11992-2, for data interchange of braking systems and running gear
L 7	1,5	ISO 7638-1 Pin 7	ABS/EBS CAN Low according to ISO 11992-1 and 11992-2, for data interchange of braking systems and running gear
L 8	6	New	Return for pin L 10
L 9	6	New	Return for pin L 11
L 10	6	New	Permanent power supply for additional equipment 1
L 11	6	New	Permanent power supply for additional equipment 2
L 12	2,5	New	Electric landing gear 1
L 13	2,5	New	Electric landing gear 2
L 14	1,5	New	Multi media
L 15	1,5	New	Multi media
R 1	1,5	ISO 12098 Pin 1	Left-hand direction indicator light
R 2	1,5	ISO 12098 Pin 2	Right-hand direction indicator light

<sup>a</sup> Nominal cross-sectional area of the conductor connected at the rear terminal of the pin and tube

**Table B.1** (continued)

<b>Contact No.</b>	<b><sup>a</sup> min mm<sup>2</sup></b>	<b>Reference</b>	<b>Function</b>
R 3	1,5	ISO 12098 Pin 3	Rear fog light
R 4	2,5	ISO 12098 Pin 4	Common return for pins R1-R3, R5-R12
R 5	1,5	ISO 12098 Pin 5	Left-hand rear positions light(s), left-hand marker lights and rear registration plate illumination
R 6	1,5	ISO 12098 Pin 6	Right-hand rear positions light(s), right-hand marker lights and rear registration plate illumination
R 7	1,5	ISO 12098 Pin 7	Stop lights
R 8	1,5	ISO 12098 Pin 8	Reversing light
R 9	1,5	ISO 12098 Pin 9	Ignition 24V
R 10	1,5	ISO 12098 Pin 10	Sensing device with common return
R 11	1,5	ISO 12098 Pin 11	Starting-traction control system
R 12	1,5	ISO 12098 Pin 12	Axle lifting device
R 13	2,5	ISO 12098 Pin 13	Common return for pin R14 and R15
R 14	1,5	ISO 12098 Pin 14	CAN High according to ISO 11992-1 and 11992-3, for data interchange of equipment other than braking systems and running gear
R 15	1,5	ISO 12098 Pin 15	CAN Low according to ISO 11992-1 and 11992-3, for data interchange of equipment other than braking systems and running gear
<b>I</b>			Control line
<b>II</b>			Supply line

<sup>a</sup> Nominal cross-sectional area of the conductor connected at the rear terminal of the pin and tube

## **Annex C** **(normative)**

### **Mixed mode operation**

#### **C.1 General**

This Annex provides information necessary for mixed mode operation; i.e. the combination of a FACS equipped tractor vehicle with a conventional semi-trailer, and the combination of a conventional tractor vehicle with a FACS equipped semi-trailer. The functional sequence is shown in Figure C.1. The electrical and pneumatic wiring diagram for both mixed mode operations are shown in Figures C.2 to C.5.

##### **C.1.1 Phase-in**

In order to support the smooth introduction of FACS-equipped vehicles into the market, the additional equipment specified in C.1.2 and C.1.3 is recommended for both, towing vehicles and semi-trailers, for at least a certain FACS phase-in period. Location of these connections on towing vehicles and semi-trailers shall conform to ISO 4009.

##### **C.1.2 Tractor vehicles**

In order to permit FACS-equipped tractor vehicles to be coupled with conventional semi-trailers having no FACS, it is recommended that tractor vehicles equipped in compliance with this Standard are in addition fitted with conventional connectors, such as:

- electrical/electronic connections in accordance with ISO 7638-1 and ISO 12098;
- pneumatic connections in accordance with ISO 1728.

##### **C.1.3 Semi-trailers**

In order to permit FACS-equipped semi-trailers to be coupled with conventional tractor vehicles having no FACS, it is recommended that the semi-trailers in compliance with this Standard are in addition fitted with conventional connectors, such as:

- electrical/electronic connections in accordance with ISO 7638-1 and ISO 12098;
- pneumatic connections in accordance with ISO 1728.

##### **C.1.4 ISO 11992 CAN cable length**

The respective lengths of the ISO 11992 CAN communication cables shall be such that the following conditions are met:

- Tractor-side harness for FACS-equipped vehicles shall not exceed a maximum length of 18 m, wherein the partial length from the ECU unit to the fixed socket shall not exceed 15 m.
- Trailer-side harness for FACS-equipped vehicles shall not exceed a maximum length of 22 m, wherein the partial length from the ECU unit to the fixed socket shall not exceed 18 m.

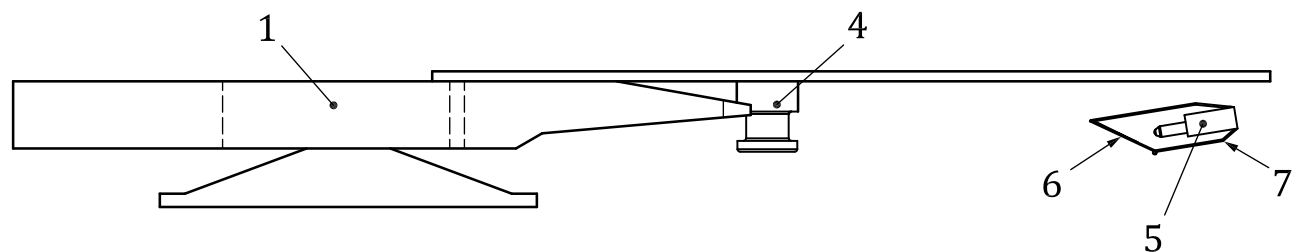

a) Main components before coupling manoeuvre

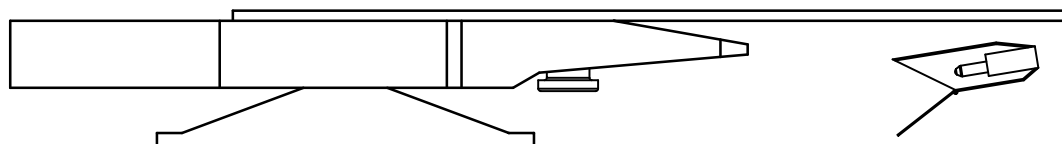

b) Tractor is moving rearwards, approaching semi-trailer. Protection cover of trailer EPI opened

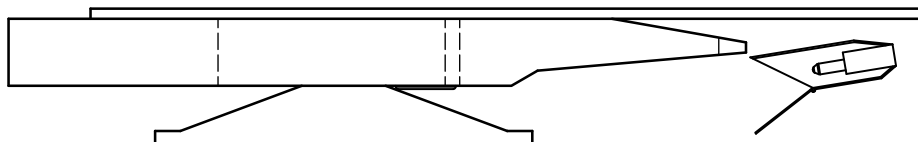

c) No counterpart available for EPI semi-trailer

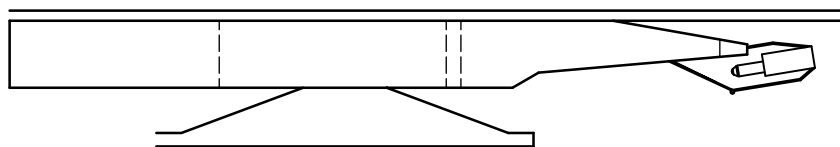

d) Protection cover closes as no EPI tractor is present. Coupling manoeuvre mechanically completed; electrical and pneumatic connections to be done manually.

**Key**

- |   |                  |   |                                       |
|---|------------------|---|---------------------------------------|
| 1 | Fifth wheel      | 6 | EPI protection cover – semi-trailer   |
| 4 | King pin         | 7 | EPI protection housing – semi-trailer |
| 5 | EPI semi-trailer |   |                                       |

**Figure C.1 — Operation sequence in mix mode — Example showing non-FACS Truck**

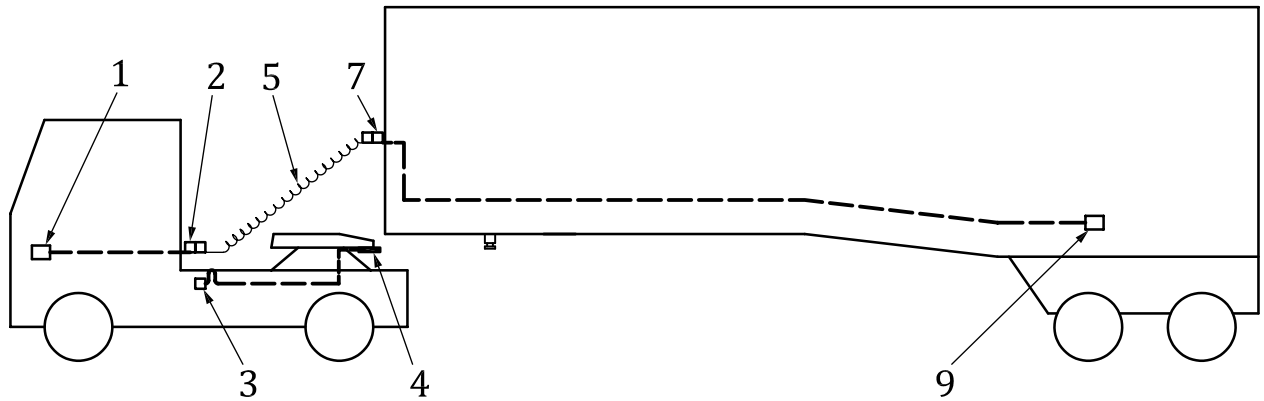

**Key**

- 1 ISO 11992-2 or ISO 11992-3 node in tractor, e.g. ECU ABS/EBS or databus device acc. ISO 12098
- 2 Bottom connector for helix cable, mounted on tractor acc. to e.g. ISO 7638-1 or ISO 12098 or other
- 3 Connector socket to FACS on tractor acc. to ISO 7638-1 or ISO 12098
- 4 Tractor-sided EPI
- 5 Helix cable
- 7 Semi-trailer-sided connector for helix cable acc. to e.g. ISO 7638-1 or ISO 12098 or other
- 9 ISO 11992-2 or ISO 11992-3 node in trailer, e.g. ECU ABS/EBS or databus device acc. ISO 12098

**Figure C.2 — Example of an electrical wiring diagram: FACS tractor, non-FACS semi-trailer**

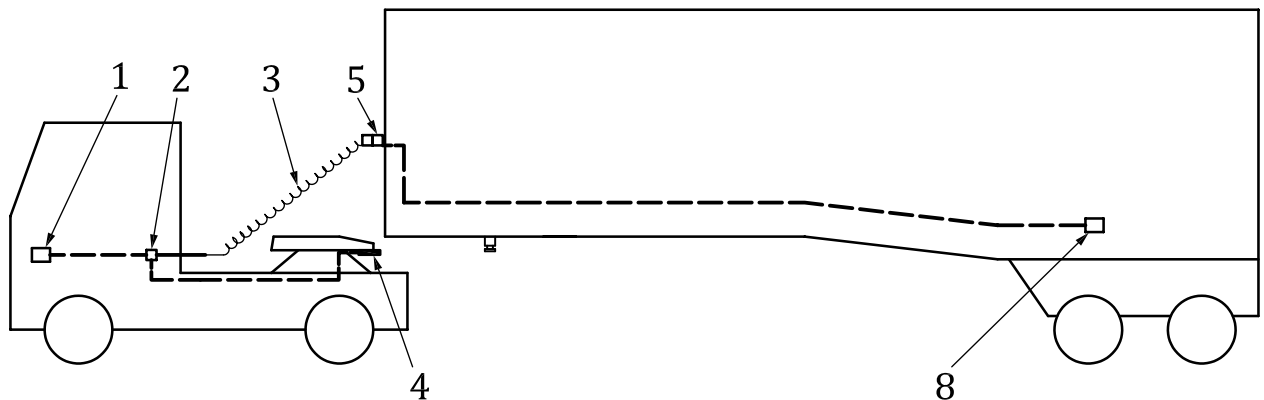

**Key**

- 1 Semi-trailer control valve mounted on tractor
- 2 T-Piece
- 3 Pneumatic helix tube
- 4 Tractor-sided EPI
- 5 Semi-trailer-sided connector for helix cable
- 8 Semi-trailer regulating valve(s)

**Figure C.3 — Example of a pneumatic tubing diagram: FACS tractor, non-FACS semi-trailer**



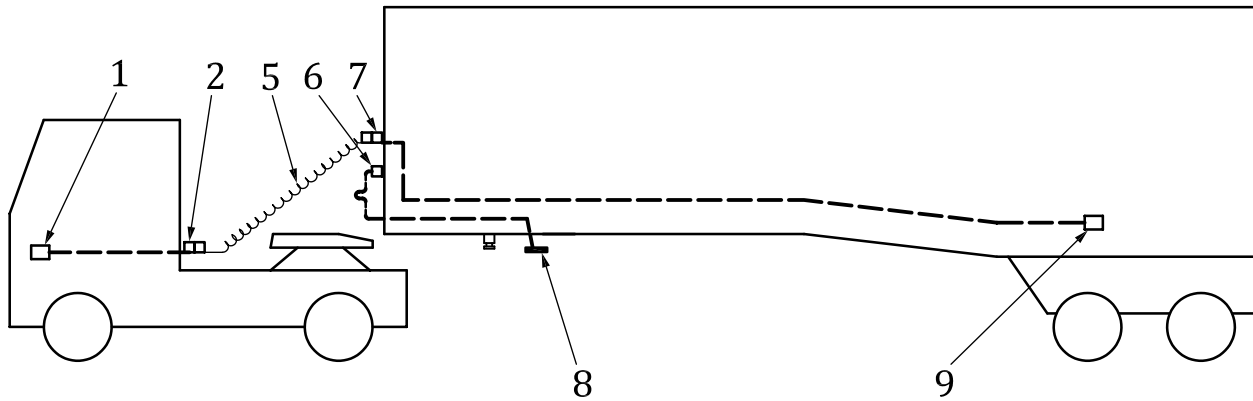

**Key**

- 1 ISO 11992-2 or ISO 11992-3 node in tractor, e.g. ECU ABS/EBS or databus device acc. ISO 12098
- 2 Bottom connector for helix cable, mounted on tractor
- 5 Helix cable
- 6 Connector socket from FACS on trailer acc. to ISO 7638-1 or ISO 12098
- 7 Trailer-sided connector for helix cable
- 8 Trailer-sided EPI
- 9 ISO 11992-2 or ISO 11992-3 node in trailer, e.g. ECU ABS/EBS or databus device acc. ISO 12098

**Figure C.4 — Example of an electrical wiring diagram: non-FACS tractor, FACS trailer**

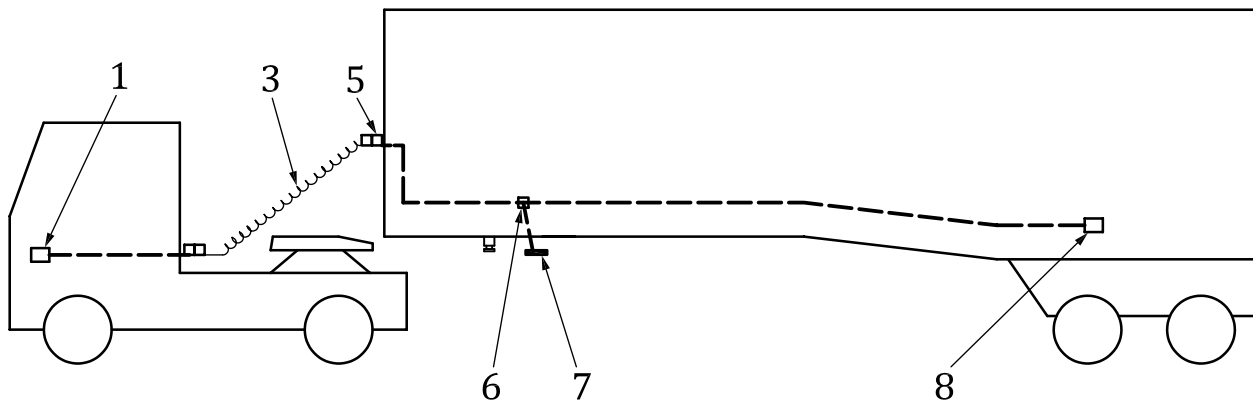

**Key**

- 1 Trailer control valve mounted on tractor
- 3 Pneumatic helix tube
- 5 Trailer-sided connector for helix cable
- 6 Automatically acting shut-off valve
- 7 Trailer-sided EPI
- 8 Trailer regulating valve(s)

**Figure C.5 — Example of a pneumatic tubing diagram: non-FACS tractor, FACS trailer**

## Bibliography

- [1] ISO 4141-1:2005, *Road vehicles — Multi-core connecting cables — Part 1: Test methods and requirements for basic performance sheathed cables*
- [2] ISO 1728, *Road vehicles — Pneumatic braking connections between motor vehicles and towed vehicles — Interchangeability*
- [3] ISO 25981, *Road vehicles — Connectors for the electrical connection of towing and towed vehicles — Connectors for electronically monitored charging systems with 12 V or 24 V nominal supply voltage*



## Template for comments and secretariat observations

Date: 23/04/2013

Document: AUE/13\_13\_0001

1	2	(3)	4	5	(6)	(7)
MB <sup>1</sup>	Clause No./ Subclause No./ Annex (e.g. 3.1)	Paragraph/ Figure/Table/ Note (e.g. Table 1)	Type of com- ment <sup>2</sup>	Comment (justification for change) by the MB	Proposed change by the MB	Secretariat observations on each comment submitted
GB	4.9		te	ISO 11992 defines the respective lengths of the electric control line. 15m for the towing vehicle, 7m for the interface cable and 18m for the trailer. These are the maximum lengths applicable to both semi-trailer combinations and truck-trailer combination. When ISO13044-2 was originally developed it was recognised that the interface cable was no longer applicable and the 7m length was shared between the towing vehicle and the trailer i.e. tractor 18m – trailer 22m. The latest version of ISO 13044 has revised these values to tractor 21m – trailer 19m. As ISO 13044-2 is specifically for semi-trailer combinations it is unjustified that for a tractor which has a wheelbase of approximately 5m requires 21m of cable whereas the semi-trailer which has a much longer wheelbase is limited to 19m. The increase of 1m for the semi-trailer does not take into account the additional length required to accommodate the articulation of the EPI unit on the semi-trailer	Revert to the original specification of 18m for the tractor and 22m for the trailer.	This is aligned with the proposal from the ACV working group in connection with the UNECE Regulation 13. ISO13044-2 will stay as is.
GB	4.9 & C.1.4		te	These paragraphs define the respective lengths of the electric control line cables however they contradict each other with regard to the maximum permitted lengths.		This a typing error. §4.9 and C.1.4. shall be aligned.
GB	5.7		ge	We have commented on ISO 13044-2 previously and each time changes are made, but they do not resolve the issues; the same can be said of the latest draft. Section 5.7 is a mismatch of requirements that are either ill defined or simply wrong. The whole section needs to be revised by someone who understands braking, otherwise interpretation problems will arise when applied.		This is left without comment as it is just a start up for the next comment
GB	5.7		te	This paragraph defines the capacitance of what is defined as the “additional cable” required for the cable to the respective EPI modules. Based on the cable values defined in paragraph 4.9 then cable length b) is 6m and cable length c) is 1m as the total is deemed to be equivalent to the length of an existing interface cable. It is impossible to connect an EPI module on the semi-trailer	The capacitance of the cable should be defined for the overall length from the respective ECU to the EPI module when each vehicle is installed with FACS only. When each vehicle is equipped for mixed mode operation then the current requirements associated with the ISO 7638 connector and EPI module must be realised and it	The matter of internal usage of the cable length is a matter of installation that is to be made such that the overall requirements are fulfilled. No action

1 **MB** = Member body (enter the ISO 3166 two-letter country code, e.g. CN for China; comments from the ISO/CS editing unit are identified by \*\*)

2 **Type of comment:** **ge** = general **te** = technical **ed** = editorial

**NOTE** Columns 1, 2, 4, 5 are compulsory.

## Template for comments and secretariat observations

Date: 23/04/2013

Document: AUE/13\_13\_0001

1	2	(3)	4	5	(6)	(7)
MB <sup>1</sup>	Clause No./ Subclause No./ Annex (e.g. 3.1)	Paragraph/ Figure/Table/ Note (e.g. Table 1)	Type of com- ment <sup>2</sup>	Comment (justification for change) by the MB	Proposed change by the MB	Secretariat observations on each comment submitted
				to the headboard of the trailer with 1m of cable as the distance from the headboard to the king pin is around 2m.	up to the vehicle manufacturer to ensure this is the case.	
GB	5.7		te	Including pneumatic and electrical installations under the heading of "Connection Resistance" is inappropriate.	Installation diagrams should be included in a separate section.	This OK according to the heading. I would have been cleaner to split it up but this is what has passed the balloting. Hence as there is no formal error no action is taken.
GB	5.7	Figure 3	ed	The connectors 2, 3, 6 & 7 are not defined in the key	These may be ISO 7638 for braking or ISO 12098 for other functions	The items 2, 3, 6, 7 are note in the key but are commented right next to the key. Hence clarity is not suffering. No action.
GB	5.7	Figure 3	ed	Title of the diagram refers to FACS installation when the diagram is for mixed mode otherwise connectors 2, 3, 6 & 7 would not be present	This whole section needs to be revised.	The comment is incorrect. The FACS installation may very well look like that. No action.
GB	5.7	Figure 3	ed	Ref 1 in the Key there is a reference to ISO 12098 this is specification of the 15 pin connector and has nothing to do with the data bus.  The same applies to Ref 9	Ref 1 text should read:  ISO 11992-2 tractor node for brakes and running gear messages or ISO 11992-3 tractor node for non brakes and running gear messages.  Ref 9 text should read:  ISO 11992-2 trailer node for brakes and running gear messages or ISO 11992-3 trailer node for non brakes and running gear messages.	This a bit unclear in the formulation. However the ISO12098 connector includes a CAN transmission. Hence there is no formal error. As this has passed the balloting the formulation shall stay as is. No action

1 **MB** = Member body (enter the ISO 3166 two-letter country code, e.g. CN for China; comments from the ISO/CS editing unit are identified by \*\*)

2 **Type of comment:** **ge** = general **te** = technical **ed** = editorial

**NOTE** Columns 1, 2, 4, 5 are compulsory.

**Template for comments and secretariat observations**

Date: 23/04/2013 Document: AUE/13\_13\_0001

GB	5.7	Figure 4	ed	Title for the diagram refers to FACS installation when diagram illustrates mixed mode installation	Revise title	The comment is incorrect. The FACS installation may very well look like that. No action.

1 **MB** = Member body (enter the ISO 3166 two-letter country code, e.g. CN for China; comments from the ISO/CS editing unit are identified by \*\*)

2 **Type of comment:** **ge** = general **te** = technical **ed** = editorial

**NOTE** Columns 1, 2, 4, 5 are compulsory.