

## **Committee of Experts on the Transport of Dangerous Goods and on the Globally Harmonized System of Classification and Labelling of Chemicals**

**Sub-Committee of Experts on the Globally Harmonized  
System of Classification and Labelling of Chemicals**

**4 December 2012**

**Twenty-fourth session**

Geneva, 12 – 14 December 2012

Item 3 of the provisional agenda

**Hazard communication issues**

### **Labelling of small packagings**

**Transmitted by the European Chemical Industry Council (CEFIC) on  
behalf of the informal correspondence group**

#### **Introduction**

1. During the present biennium, after considering that developing guidance on the application of the general principles for the labelling of small packagings was premature, the informal correspondence group drafted illustrative examples on how the general principles for the labelling of small packagings described in paragraph 1.4.10.5.4.4 of the GHS may be applied.

#### **Development of examples of labelling of small packagings**

2. Five examples were proposed as illustrations of the application of the general principles. As such, they were not meant to be taken as recommendations or as setting precedents. They also do not cover the full range of possibilities to accommodate GHS label elements for small packagings (i.e. other labelling arrangements not reflected in the developed examples could also be conceived).

3. The members of the sub-committee were invited to comment on successive drafts for these examples during the biennium.

4. At this stage, an agreement was not reached on the publication of these examples, either in an annex to the GHS or on the UNECE secretariat's website. However, it seems that two goals have been achieved:

- (a) The issues facing companies when trying to apply GHS labels on small packagings have been clearly identified;
- (b) The comments received, especially those asking for consistency between the adopted solutions in the examples, suggest they may be used as a basis to develop/agree consistent solutions in the next biennium.

## Proposal for the next biennium

5. While developing the above mentioned examples, the following issues were identified for further discussion by the correspondence group with a view to bringing forward recommended solutions for the sub-committee's consideration in the next biennium:

- (a) General issue of the redundancy of precautionary statements which requires first the consideration of the outcome of the informal correspondence group on annexes 1, 2 and 3;
- (b) Possible standardization of hazard information provided on inner labels for small packages;
- (c) Appropriateness of the inclusion of provisions regarding the minimum size of pictograms or text to ensure the readability of the information shown on the labels;
- (d) Difficulty to accommodate the labelling requirements and the need to give instructions for use which may be important for safety (see example 2);
- (e) Lay out of the pictograms: contiguous (sharing the red border) or separate?
- (f) Possibility to include in the GHS provisions like those that exist in TDG regulations: creation of a simple generic symbol that would be more legible and could replace several - too small - symbols on very small packagings.
- (g) Possibility to define minimum label elements required on a label where it is impossible to include a full label even by using tie-on or fold-out labels (see example 1 (a)).
- (h) Possibility to define precedence of hazard pictograms (similar to current TDG regulations for precedence of hazard characteristics) in the case where two or more hazard pictograms are required on a label for a very small packaging (see example 1 (a)).
- (i) Possibility to define requirements for use of fold-out labels e.g. what label elements must go on the front page and what elements could appear on the internal fold-out page(s) (see example 1 (a)).

6. It is proposed that the sub-committee adds this work item on the agenda for the biennium 2013-2014.

## Annex

### Examples of labelling of small packagings

#### Introduction

1. The examples that follow are included as working material for the correspondence group and the Sub-Committee.
2. They illustrate how suppliers of chemicals have sought to meet the principles in 1.4.10.5.4.4 when labelling small packages in accordance with the GHS. These examples are illustrative only and adopting the same or similar approaches does not guarantee compliance with Competent Authority requirements in any jurisdiction.
3. Since the 23<sup>rd</sup> session, the 5 examples have only been reorganized according to the types of small packagings covered. They have not been modified to take into account the comments dealing with a lack of consistency between the examples as it was felt that different approaches need to be offered at the present stage in order to allow the correspondence group to take several options into consideration before [eventually] adopting a position.
4. **[Reminder:** para. 1.4.10.5.4.4 of GHS: Labelling of small packagings  
“The general principles that should underpin labelling of small packagings are:
  - (a) All the applicable GHS label elements should appear on the immediate container of a hazardous substance or mixture where possible;
  - (b) Where it is impossible to put all the applicable label elements on the immediate container itself, other methods of providing the full hazard information should be used in accordance with the definition of “Label” in the GHS. Factors influencing this include *inter alia*:
    - (i) the shape, form or size of the immediate container;
    - (ii) the number of label elements to be included, particularly where the substance or mixture meets the classification criteria for multiple hazard classes;
    - (iii) the need for label elements to appear in more than one official language.
  - (c) Where the volume of a hazardous substance or mixture is so low and the supplier has data demonstrating, and the competent authority has determined, that there is no likelihood of harm to human health and/or the environment, then the label elements may be omitted from the immediate container;
  - (d) Competent authorities may allow certain label elements to be omitted from the immediate container for certain hazard classes/categories where the volume of the substance or mixture is below a certain amount;
  - (e) Some labelling elements on the immediate container may need to be accessible throughout the life of the product, e.g. for continuous use by workers or consumers.”].

5. The following template was used for each of the examples:
- (a) Substance/mixture
  - (b) Use
  - (c) Classification (Hazard classes and categories)
  - (d) Full labelling information
  - (e) Packaging description and size
  - (f) Labelling problems encountered
  - (g) Adopted solution
    - (i) Immediate container (description, thought process, illustration)
    - (ii) Outside packaging<sup>1</sup> (description, illustration)
6. The five examples are organised as follows:
- **Example 1:** Small immediate container in a container which can display the entire information required on the label
    - (a) Immediate container that cannot be labelled based on restrictions for the use:  
Cardboard box containing 5 ampoules
    - (b) Immediate container that can be labelled:  
Cleaning pads in dispenser box
  - **Example 2:** Small immediate container in an outer container which is also too small to display the complete information
    - Immediate container in a blister for end-users/consumers where additional instructions for use are required, information needs to be reduced on the immediate and on the outer package:  
Cleaning pen with blister
  - **Example 3:** Kits consisting of one or more different products in a medium size outer package, which is used to store the immediate containers until the use
    - (a) Immediate container displays some of the required information, the outer package displays most of the required information:  
Styrofoam box with 25 ampoules
    - (b) Different immediate containers which are indicated with a letter on the closure, complete information required is displayed with reference to these letters on the outer of the package:  
Box containing ampoules and reagents

---

<sup>1</sup> The wording “outside packaging” here does not have the same meaning as the term outer packaging in Transport of Dangerous Goods (TDG) regulations. An outside packaging should be regarded as an inner or intermediate packaging according to TDG regulations, requiring an outer packaging for transport.

**Example 1:****Small immediate container in a container which can display the entire information required on the label****(a) Immediate container that cannot be labelled based on restrictions for the use: Cardboard box containing 5 ampoules****(i) Substance:**

5 ampoules of blahzenic acid supplied in a cardboard box

**(ii) Use:**

Laboratory reagent – professional use

**(iii) Classification**

Acute toxicity oral Cat 2

Acute toxicity dermal Cat 1

Acute toxicity inhalation Cat 2

Skin corrosion Cat 1B

**(iv) Full labelling information****• Pictograms:****• Signal word:**

Danger

**• Hazard statements:**

H300+H310+H330 Fatal if swallowed, in contact with skin or if inhaled

H314 Causes severe skin burns and eye damage

**• Precautionary statements**

(as assigned to the respective hazard categories in GHS Annex 3, Section 3 taking into account use/application, the number of precautionary statements required on the actual label may be reduced by excluding redundant/similar statements):

**Prevention:**

P264 Wash...thoroughly after handling

P270 Do not eat, drink or smoke when using this product

P262 Do not get in eyes, on skin or on clothing

P280 Wear protective gloves/protective clothing/eye protection/face protection

P260 Do not breathe dust/fume/gas/mist/vapours/spray

P271 Use only outdoors or in a well-ventilated area

P284 Wear respiratory protection

**Response:**

P301+P310: IF SWALLOWED: Immediately call a POISON CENTER / doctor/...

P321 Specific treatment (see ... on this label)

P330 Rinse mouth;

P302+P352: IF ON SKIN: Gently wash with plenty of water /...

P310 Immediately call a POISON CENTER/doctor/...;

P361+ P364: Take off immediately all contaminated clothing and wash it before reuse.

P363 Wash contaminated clothing before reuse

P304+P340: IF INHALED: Remove person to fresh air and keep comfortable for breathing

P320 Specific treatment is urgent (see ... on this label)

P301+P330+P331: IF SWALLOWED: Rinse mouth. Do NOT induce vomiting;

P303+P361+P353: IF ON SKIN (or hair): Take off all contaminated clothing. Rinse skin with water/shower

P305+P351+P338: IF IN EYES: Rinse cautiously with water for several minutes. Remove contact lenses, if present and easy to do. Continue rinsing.

**Storage:**

P405 Store locked up

P403+P233

Store in a well-ventilated place; Keep container tightly closed.

**Disposal:**

P501 Dispose of contents/container to...

**(v) Packaging description and size**

Cardboard box containing 5 glass ampoules. Each ampoule contains 0.5 grams blazhenic acid

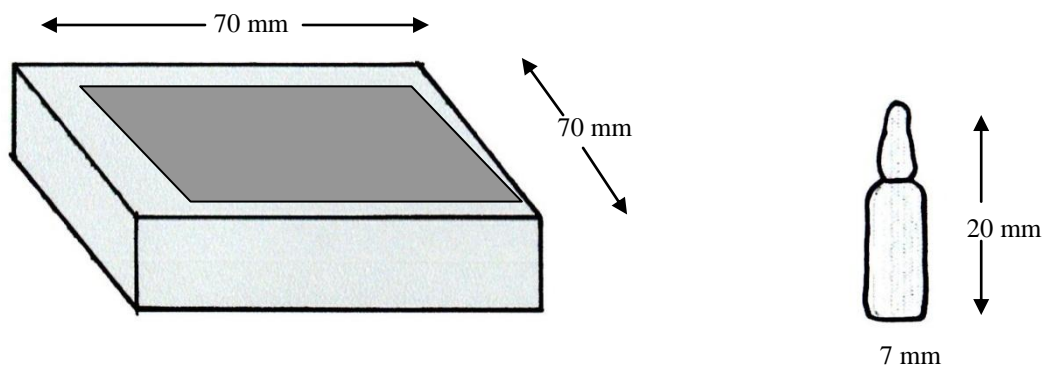

**(vi) Labelling problems encountered**

The working solution of this reagent is prepared by removing the top of the ampoule and placing the bottom half (containing the substance) in the required amount of deionized water. Consequently, labels cannot be applied to the actual ampoules as they may contaminate the working solution, which may affect subsequent reactions. It is impossible to put all applicable GHS label elements on the immediate container (i.e. the glass ampoule) due to its size and shape.

The area available on the outer cardboard box is large enough to carry a legible version of the required GHS label elements in a single language. Legibility is reduced if labelling in more than one official language is required. Legibility is also a concern in any labelling for the glass ampoule.

**(vii) Adopted solution****Immediate container**

The GHS definition of “Label” indicates that the required label elements can be “affixed to, printed on, or attached to the immediate container of a hazardous product”. As it is not possible to print on the ampoule or attach a label, the adopted solution is to seal the unlabelled ampoule in a polythene sleeve with an end tag for a label. The ampoule is not removed from the polythene sleeve until the point of intended use, i.e. preparation of the working solution.

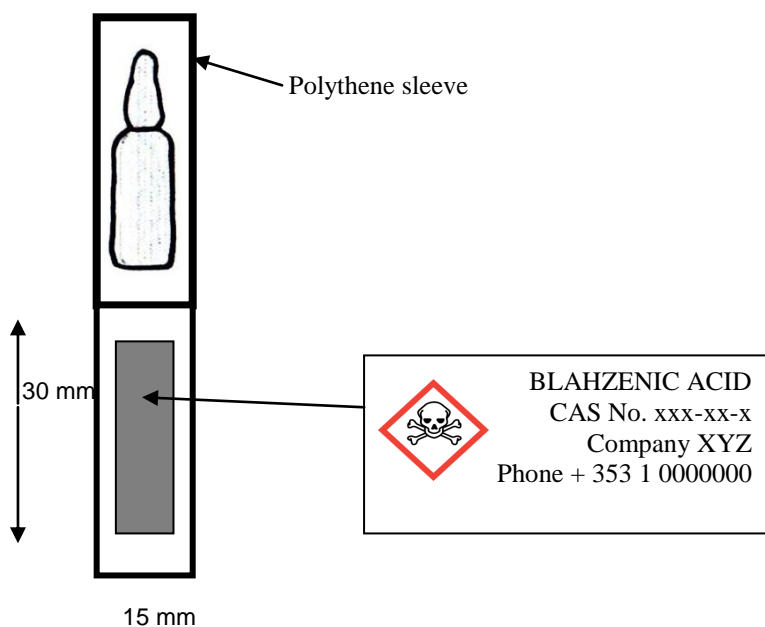

The area available for a label on the end tag is not sufficient to include all required label elements. The adopted solution is to include at least the hazard pictograms, product identifier and name plus telephone number of the supplier. This ensures that the user is aware of the substance identity (enables identification of the associated substance SDS), its hazards (indicates that the substance is hazardous and needs to be handled/stored appropriately) and the name/contact details of the supplier (if needed in an emergency situation). All required label elements appear on the outside packaging.



Blahzenic acid is required to carry the signal word “danger” on the label. Signal words alert the user to the relative severity of hazard. However, taking into account the restricted space on the end tag, the signal word is omitted in this instance on the basis that the user is also alerted to the hazard and its relative severity by the hazard pictogram.

Blahzenic acid is required to carry the skull and crossbones and corrosion pictograms. The area available for a label on the end tag means that it is difficult to include two identifiable pictograms without impacting on the legibility of the other label text. Taking into account the small amount of substance in each ampoule, the adopted solution is an approach similar to that in the Model Regulations on precedence of hazard characteristics. Blahzenic acid is classified as Class 6.1 Packing Group I (dermal) and Class 8 Packing Group II. Table 2.0.3.3 in Chapter 2.0 of the Model Regulations indicates that Class 6.1 Packing Group I (dermal) takes precedence over Class 8 Packing Group II (solid). Accordingly, only the skull and crossbones pictogram appears on the end tag label. Both hazard pictograms appear on the outside packaging.

### Outside packaging

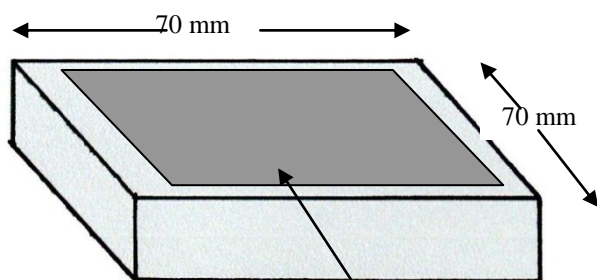
Taking into account use/application, the number of precautionary statements required on the label may be reduced by excluding redundant/similar statements.



BLAHZENIC ACID CAS No. xxx-xx-xx	
DANGER	
	<p>Fatal if swallowed, in contact with skin or if inhaled Causes severe skin burns and eye damage</p>
	<p>Wear protective gloves /clothing and eye/face protection. IF ON SKIN (or hair): Take off immediately all contaminated clothing. Rinse skin with water / shower. IF IN EYES: Rinse cautiously with water for several minutes. Remove contact lenses, if present and easy to do. Continue rinsing. Immediately call a POISON CENTER or doctor IF SWALLOWED: Rinse mouth. Do NOT induce vomiting. Immediately call a POISON CENTER or doctor IF INHALED: Remove person to fresh air and keep comfortable for breathing. Immediately call a POISON CENTER or doctor Wash contaminated clothing before reuse. Wash hands thoroughly after handling. Do not eat, drink or smoke when using this product. Store locked up Dispose of contents/container to a hazardous waste disposal site</p>
	
<p>Company XYZ, Alphabet Street, Sometown, Any country, Code ABCD Phone: + 353 1 0000000</p>	



Where the country in which the product is used has more than one official language, it may not be possible to produce a legible label for the outside packaging. In this instance (and to avoid using larger packaging), the adopted solution is to use a fold-out label. The hazard pictograms, signal word, hazard statements (in the required official languages) and supplier details appear on the front of the folded label whilst the precautionary statements and other supplemental information appear in the fold-out part. The fold-out label is produced in a way such that the front part cannot be detached from the remainder of the label or the outside packaging.

**(b) Immediate container that can be labelled: Cleaning pads in dispenser box**

**(i) Substance/mixture:**

Cleaning fluid absorbed in pads. The amount of liquid incorporated in each pad is < 10 ml. There is no free liquid.

**(ii) Use:**

The product is used by consumers to clean screens, glasses or other surfaces.

**(iii) Classification**

Hazard classes and categories of the cleaning fluid:

**Physical:** Flammable Liquid Cat 2

**Health:** Eye Irritation Cat 2

STOT Single Exposure Cat 3

**(iv) Full labelling information**

• **Pictograms**



• **Signal word**

Danger

• **Hazard statements**

Hazard Statements-Physical: H225 Highly flammable liquid and vapour

Hazard Statements-Health: H336: May cause drowsiness or dizziness

H319: Causes serious eye irritation.

• **Precautionary statements**

(as assigned in GHS Annex 3, Section 3):

**General:**

Keep out of reach of children.

**Prevention:**

P210 Keep away from heat/ sparks/open flames/hot surfaces. — No smoking

- P233 Keep container tightly closed.
- P240 Ground/bond container and receiving equipment
- P241 Use explosion-proof electrical/ventilating/lighting equipment.
- P242 Use only non-sparking tools
- P243 Take precautionary measures against static discharge.
- P261 Avoid breathing dust/fume/ gas/mist/vapours/spray.
- P264 Wash hands thoroughly after handling.
- P271 Use only outdoors or in a well-ventilated area.
- P280 Wear protective gloves/protective clothing/eye protection/ face protection.

**Response:**

P303 + P361 + P353:

IF ON SKIN (or hair): Take off immediately all contaminated clothing. Rinse skin with water/shower.

P304 + P340:

IF INHALED: Remove person to fresh air and keep comfortable for breathing.

P305 + P351 + P338

IF IN EYES: Rinse cautiously with water for several minutes. Remove contact lenses, if present and easy to do. Continue rinsing.

P312 Call a POISON CENTER/ doctor/... if you feel unwell.

P337 + P313

If eye irritation persists: Get medical advice/attention.

P370 + P378

In case of fire: Use carbon dioxide for extinction.

**Storage:**

P403 + P233 Store in a well-ventilated place. Keep container tightly closed.

P235 Keep cool.

P405 Store locked up.

**Disposal:**

P501 Dispose of contents/container in accordance with applicable local/regional/national/international regulations.

**(v) Packaging description and size**

The cleaning tissue is sealed in a multilayer bag, consisting of paper and plastic material. The dimensions are: 35 x 75 mm. 500 cleaning pads are packed in one dispenser box. The dispenser box offers the possibility to take out the cleaning bags one by one.

**(vi) Labelling problems encountered**

The immediate container (bag) is very small and the possible label size is further reduced because users have to be able to tear the package without ripping the label itself, and because in this case the label has to be in more than 1 language. . The pictograms cannot be reduced any further in size without the risk that the symbols become unidentifiable.

The outer package is a dispenser box, from which bags are normally removed one by one. This means the dispenser box is present when the product is used and so label elements on the outer package will be available during use.

## (vii) Adopted solution

### Immediate container

The limited label size on the immediate container (bag) means that, with the approval of the competent authority, some label elements are omitted in accordance with 1.4.10.5.4.4 (d). As pictograms are a good tool to provide the hazard information, they are as large as possible and to achieve this, no signal word, H- or P-statements are included on the immediate container. The telephone number of the supplier is included, but in a legible small text font, because it is repeated on the outer package, which is the dispenser for the cleaning pads and therefore available through the lifetime of the product.

The label on the immediate container, therefore, is limited to the pictograms, the product identifier and the address and telephone number of the supplier. This minimizes the language specific information on the label of the immediate container.

### Bag

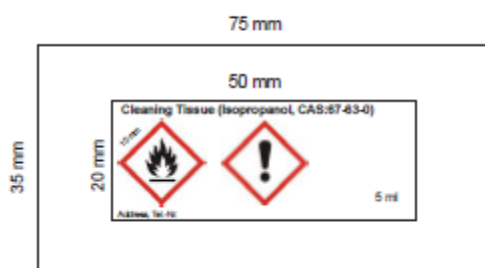

### Outside packaging

On the outer package the full information can be displayed, although the number of P-Statements is reduced, to avoid long texts, which wouldn't be read by the consumer. Selection of the appropriate P statements is based on the use and quantity of the product. In this case the P statements:

- P403 + P233 Store in a well-ventilated place. Keep container tightly closed.
- P235 Keep cool.
- P405 Store locked up.

are not considered appropriate, as the product is in single use packages.

The same applies to all P-Statements which refer to extinguishing media or handling tools.

In addition reducing the number of P statements focuses on the most important information. Another benefit is, that more than one language can be applied (which in some countries is a legal requirement). The following label elements appear on the outside packaging:

- Pictograms (16 x 16 mm)
- Signal word
- H-statements
- P-statements
- Address and telephone number of the supplier
- Product identifier

# Box

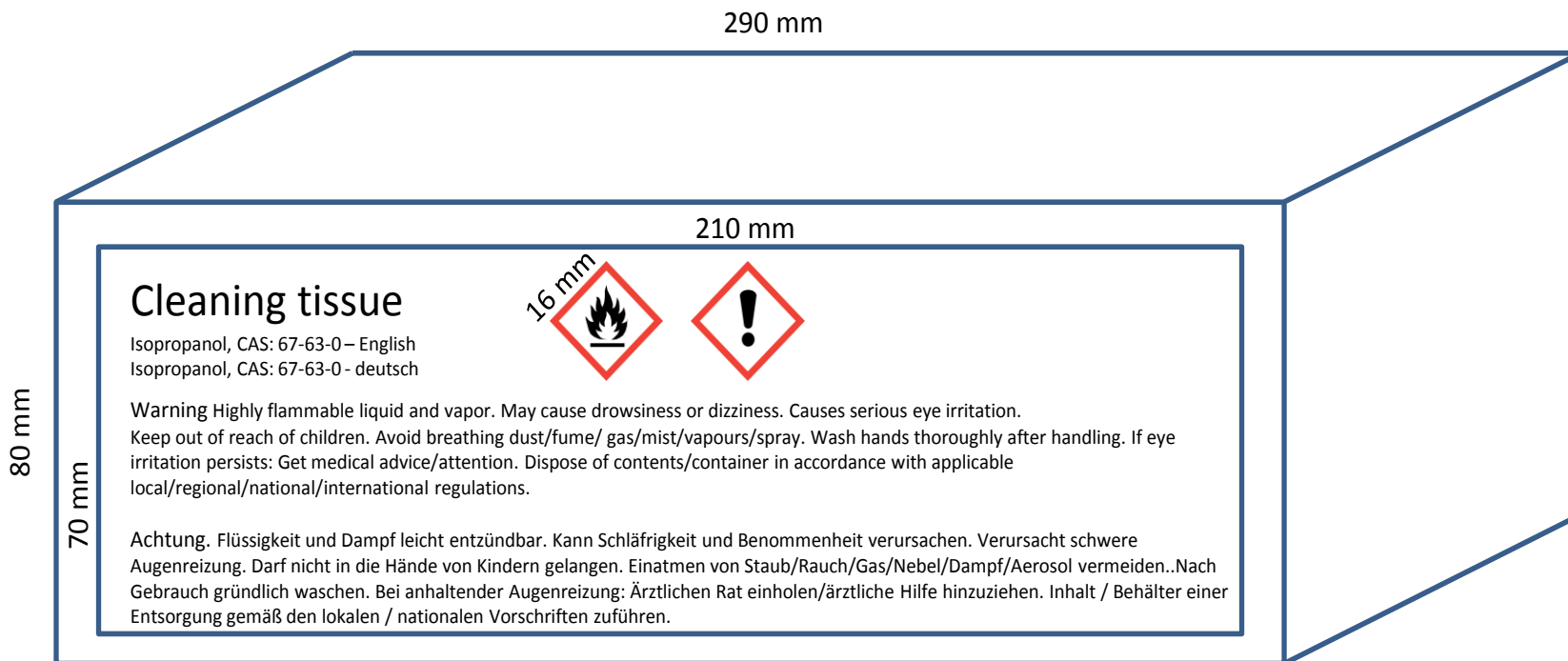

## Example 2:

### Small immediate container in an outer container which is also too small to display the complete information

**Immediate container in a blister for end-users/consumers where additional instructions for use are required, information needs to be reduced on the immediate and on the outer package: Cleaning pen with blister**

**(i) Substance/mixture:**

Cleaning fluid in a pen

**(ii) Use:**

Consumer product to remove adhesive, label and sticker residue and marker graffiti. A pen enables easy application and avoids the need for direct contact with the cleaning fluid.

**(iii) Classification**

**Physical:** Flammable liquid Cat. 3

**Environmental:** Acute aquatic hazard Cat. Acute 1  
Long-term aquatic hazard Cat. Chronic 1

**Health:** Acute toxicity (oral) Cat. 5  
Serious eye damage/irritation Cat. 2B  
Skin corrosion/irritation Cat. 3  
Skin sensitizer Cat. 1

**(iv) Full labelling information**

• **Pictograms**



• **Signal word**

Warning

• **Hazard statements**

Hazard Statements-Physical: H226 Flammable liquid and vapour

Hazard Statements-Health: H303 May be harmful if swallowed

H320 Causes eye irritation

H316 Causes mild skin irritation

H317 May cause an allergic skin reaction

- **Precautionary statements**

(as assigned in GHS Annex 3, Section 3):

**General:**

P102 Keep out of reach of children

**Prevention:**

P210 Keep away from heat/sparks/open flames/hot surfaces. - No smoking.

P240 Ground/bond container and receiving equipment.

P242 Use only non-sparking tools.

P243 Take precautionary measures against static discharge.

P233 Keep container tightly closed.

P241 Use explosion-proof electrical/ventilating/lighting/equipment.

P261 Avoid breathing dust/fume/gas/mist/vapours/spray.

P280 Wear protective gloves and eye/face protection.

P264 Wash thoroughly after handling.

P272 Contaminated work clothing should not be allowed out of the workplace.

P273 Avoid release to the environment.

**Response:**

P305 + P351 + P338

IF IN EYES: Rinse cautiously with water for several minutes. Remove contact lenses, if present and easy to do. Continue rinsing.

P337 + P313

If eye irritation persists: Get medical advice/attention.

P303+P361+P353

IF ON SKIN (or hair): Remove/Take off immediately all contaminated clothing. Rinse skin with water/shower.

P302 + P352

IF ON SKIN: Wash with plenty of water/...

P333+P313

If skin irritation or rash occurs: Get medical advice/attention.

P363 Wash contaminated clothing before reuse.

P312 Call a POISON CENTER/ doctor/... if you feel unwell.

P370+P378

In case of fire use a carbon dioxide or dry chemical extinguisher for extinction.

P391 Collect spillage.

**Storage:**

P403+P235

Store in a well-ventilated place. Keep cool.

**Disposal:**

P501 Dispose of contents/container in accordance with applicable local/regional/national/international regulations.

**(v) Packaging description and size**

The cleaning pen has the following dimensions: 140mm x 14mm. It looks like a normal round marker, but is filled with a liquid to remove adhesive, label residue and marker graffiti. The liquid in the pen is a clear solution, which is applied via a wick. The pen contains 0,01 litre of liquid (=8,2 g). Each pen is packed in a blister and 12 blisters are packaged in a fibreboard box for transport. In the retail shop the pen is sold only with the blister as outer package. The label is wrapped around the pen and contains instructions on use as well as GHS labelling information. The dimensions of the label are 45 mm x 100 mm.

**Pen:**

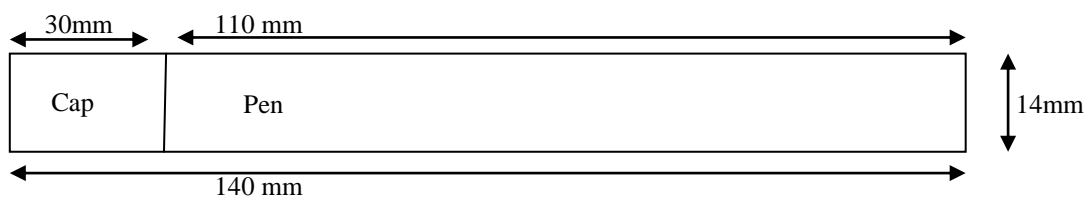

**Blister:**

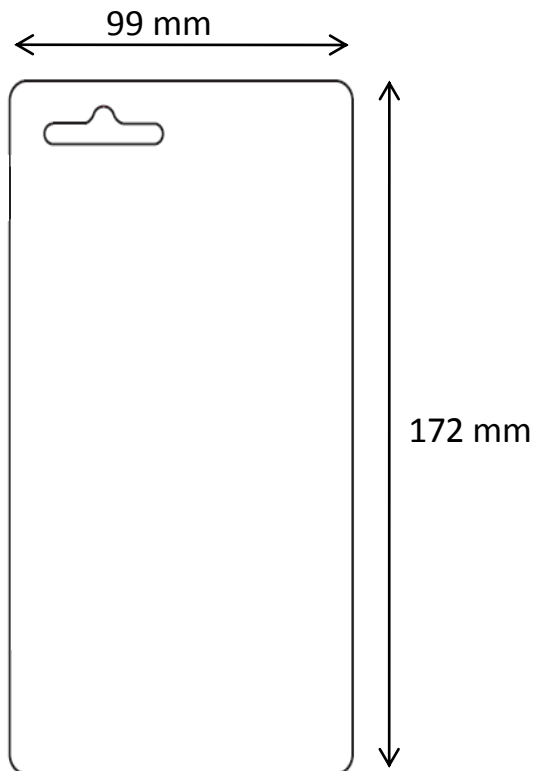



**(vi) Labelling problems encountered**

There is not enough space on the label on the immediate container (pen) to add all the information in accordance with chapter 1.4.10.5 of GHS, even if the size of the text is very small. The pictograms take up nearly 1/3 of the available label space, because 3 pictograms are required. In addition, as this is a consumer product, instructions for the correct use need to be given on the pen-label.

There is more space on the blister, but up to 3 languages are required for some countries, so that there is still not enough space to provide all label elements.

**(vii) Adopted solution****Immediate container**

The label elements are reduced to give an indication of the hazards. Therefore, in accordance with 1.4.10.5.4.4.(d), the following label elements appear on the immediate container:

- pictograms (size of 16 x 16 mm)
- product identification (Cleaner pen)
- address and telephone number of the supplier
- net volume
- instructions for proper use

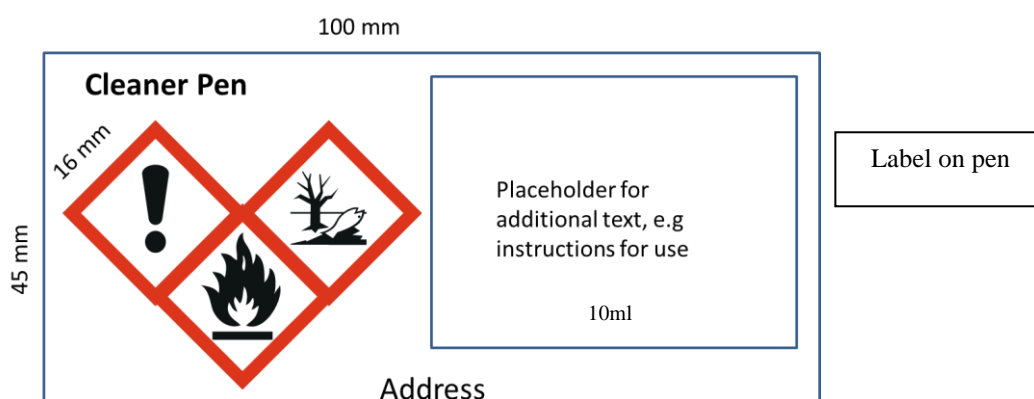
**Outside packaging**

The available space is still not sufficient to display all label elements. Therefore, with the approval of the competent authority, only the most important label elements are displayed in the relevant languages. Providing more information would reduce the size of the text, making it unreadable. Consumer products require detailed instructions for use, which must be included on the label in conjunction with the GHS hazard information. In order to accommodate all the requisite information, some label elements are omitted from the label, because otherwise the text would be unreadable. The adopted solution is therefore to use expert judgment to identify the H- and P-statements for the most severe hazards, and to ensure that as many as possible appear on the label. The other hazards are still communicated via the pictograms and the signal word. This approach also reflects the very small amount of product (below 125 ml). The example also shows labelling for a country which

requires more than one official language on the product, which reduces the space for the text even more.

In this case the most severe hazard for the user was judged to be the hazard of sensitization. The flammability and environmental hazards have been excluded based on the small amount of product available in the inner package. The following label elements appear on the blister:

- product identifier (Cleaner pen), including hazardous ingredient
- pictograms (size 16 x 16 mm)
- signal word (bigger than text of H- and P-Statements)
- H-statements for sensitising hazard
- P-statements for sensitising hazard
- Address and telephone number of supplier
- Net volume
- Instructions for use

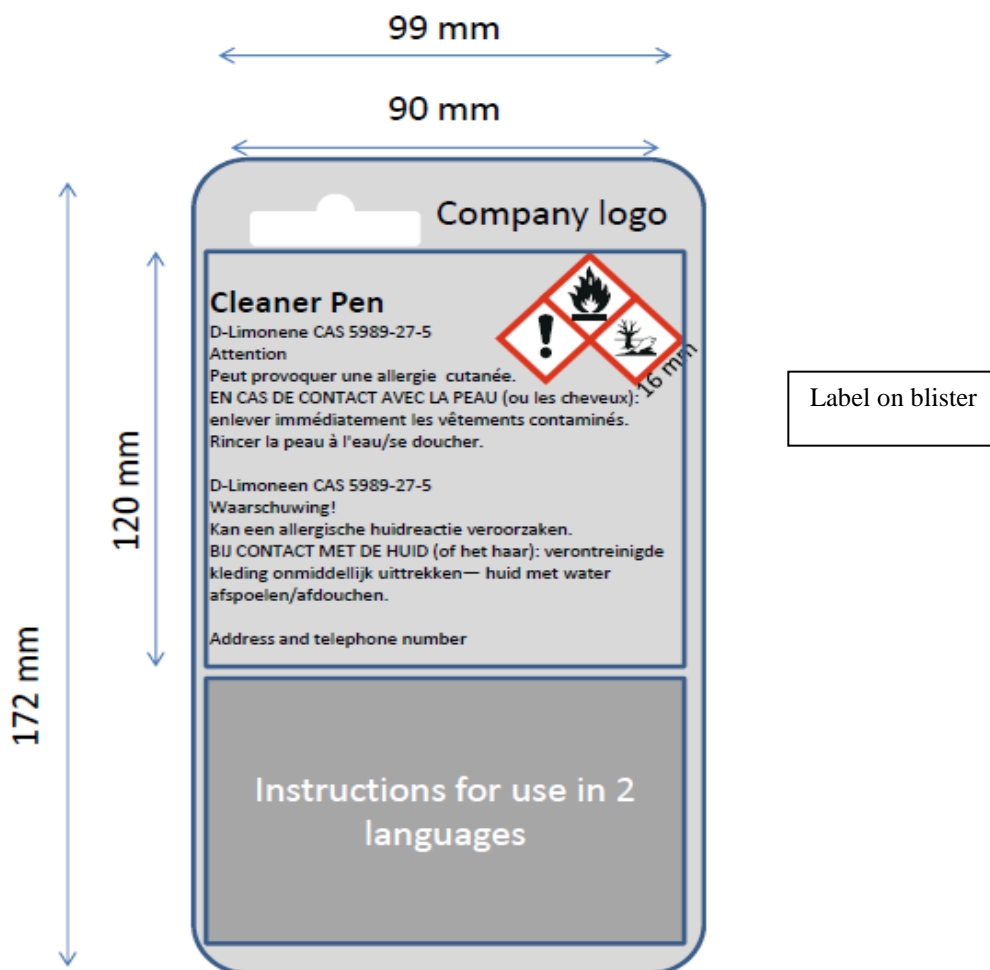

### Example 3:

#### **Kits consisting of one or more different products in a medium size outer package, which is used to store the immediate containers until use**

(a) **Immediate container displays some of the required information, the outer package displays most of the required information: Styrofoam box with 25 ampoules**

(i) **Mixture:**

25 glass ampoules of reagent containing sulfuric acid and mercury (II)-sulfate in a styrofoam box.

(ii) **Use:**

Reagent-Kit for water analysis – industrial use.

(iii) **Classification**

**Health:** Corrosive to metals Cat. 1

Acute toxicity Cat. 3 (dermal, oral, inhalation)

Skin corrosion Cat. 1A

STOT Repeated exposure Cat. 2

**Environmental:** Long-term aquatic hazard Cat. Chronic 3

(iv) **Full labelling information**

• **Pictograms**



• **Signal word**

Danger

• **Hazard statements**

H290: May be corrosive to metals

H301+H311+H331: Toxic if swallowed, in contact with skin or if inhaled

H314: Causes severe skin burns and eye damage

H373: May cause damage to organs through prolonged or repeated exposure

H412: Harmful to aquatic life with long lasting effects

• **Precautionary statements**

(as assigned in GHS Annex 3, Section 3):

**Prevention:**

P264: Wash hands thoroughly after handling

P270: Do not eat drink or smoke when using this product

P280: Wear protective gloves/protective clothing/eye protection/face protection

P260: Do not breathe vapour

P271: Use only outdoors or in a well ventilated area

P273: Avoid release to the environment

**Response:**

P390: Adsorb spillage to prevent material-damage

P330: Rinse mouth

P302+P352:

IF ON SKIN: wash with plenty of water

P310: Immediately call a POISON CENTER or doctor

P311: Call a POISON CENTER or doctor

P312: Call a POISON CENTER or doctor if you feel unwell

P301+P310

IF SWALLOWED: Immediately call a POISON CENTER or doctor

P314: Get medical advice/attention if you feel unwell

P361 + P364:

Take off immediately all contaminated clothing and wash it before reuse

P363: Wash contaminated clothing before reuse

P304+P340

IF INHALED: Remove person to fresh air and keep comfortable for breathing

P301+P330+P331

IF SWALLOWED: Rinse mouth. Do not induce vomiting

P303+P361+P353

IF ON SKIN (or hair): Take off immediately all contaminated clothing. Rinse skin with water/shower

P305+P351+P338:

IF IN EYES: Rinse cautiously with water for several minutes. Remove contact lenses, if present and easy to do. Continue rinsing

**Storage:**

P406: Store in a corrosive resistant container with a resistant inner liner

P405: Store locked up

P403+P233:

Store in a well ventilated place. Keep container tightly closed

**Disposal:**

P501 Dispose of contents/container in accordance with local regulation.

**(v) Packaging description and size**

Styrofoam box containing 25 glass ampoules. Each ampoule is filled with 3.5 ml of the same mixture. (total volume: 87,5 ml)

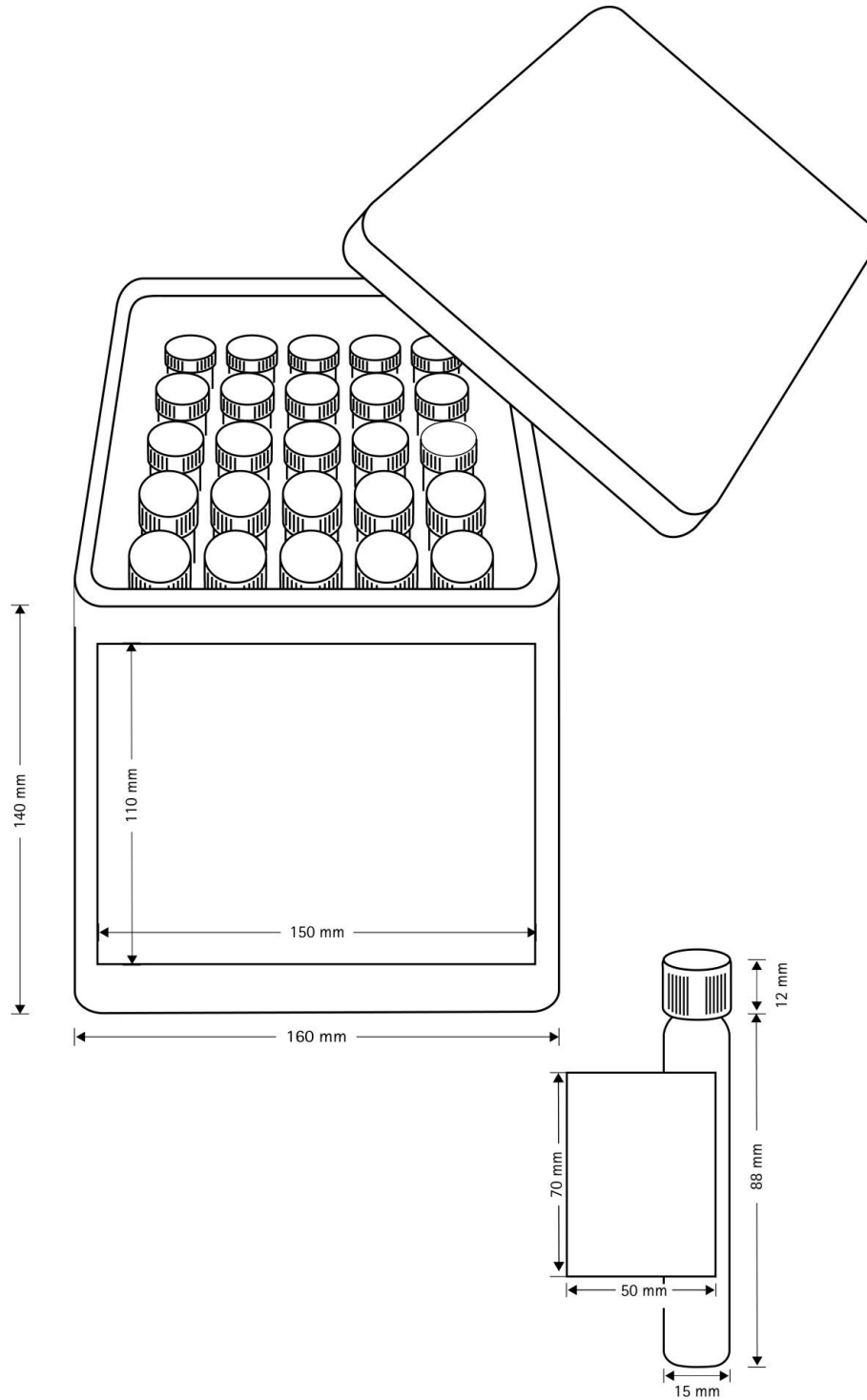

**(vi) Labelling problems encountered**

Because of the hazards of the mixture, 25 precautionary statements are triggered (Annex 3, section 3). There is considerable overlap in the information provided and not all the information is relevant for this particular use because of the quantity of the reagent supplied, its concentration and because it is used by trained personnel in a laboratory. Such use can be distinguished from the supply of much larger quantities (hundreds or thousands of litres) for filling, packaging, or chemical processing activities.

The limited space for labels, particularly on the ampoules, means it is impossible to fit all the labelling elements in the available space in a clear and legible way, even on the outer packaging. Putting too much on a label of limited size can lead to users ignoring important information. Multi-lingual labelling, desirable where the same product is supplied in different countries, becomes impossible.

**(vii) Adopted solution**

To alert the user to the most severe hazards of the mixture and to indicate the most important measures to minimize or prevent adverse effects in relation to this application and the quantities used the following approach is adopted for the label on the box:

**Redundant/similar** precautionary statements are removed, taking a conservative approach with respect to concentration, volume and use:

P260: Do not breathe vapour

~~P261: Avoid breathing dust/fume/gas/mist/vapours/spray~~

~~P271: Use only outdoors or in a well ventilated area~~

~~P330: Rinse mouth~~

P301+P330+P331 IF SWALLOWED: Rinse mouth. Do not induce vomiting

~~P310: Immediately call a POISON CENTER/ doctor/...~~

~~P311: Call a POISON CENTER/ doctor/...~~

~~P312: Call a POISON CENTER/ doctor/.../ if you feel unwell~~

P301+P310 IF SWALLOWED: Immediately call a POISON CENTER or doctor

P314: Get medical advice/attention if you feel unwell.

~~P302+P352: IF ON SKIN: wash with plenty of water/...~~

P303+P361+P353 IF ON SKIN (or hair): Take off immediately all contaminated clothing. Rinse skin with water/shower

~~P361 + P364 : Take off immediately all contaminated clothing and wash it before reuse.~~

Precautionary statements addressing workplace protection/operating instructions are removed from the label because the SDS provides general information and guidance for handling and for storage and disposal:

P260: Do not breathe vapour

P264: Wash hands thoroughly after handling

P270: Do not eat drink or smoke when using this product

P390: Adsorb spillage to prevent material-damage

P363: Wash contaminated clothing before reuse

P406: Store in a corrosive resistant container with a resistant inner liner

P405: Store locked up

P403+P233: Store in a well ventilated place. Keep container tightly closed.

P501: Dispose of contents/container in accordance with local regulation

**P-Statements included on the label on the box:**

- P280: Wear protective gloves/protective clothing/eye protection/face protection
- P273: Avoid release to the environment
- ~~(P301+P310 IF SWALLOWED: Immediately call a POISON CENTER/doctor/...)~~
- P301+P330+P331+P310 IF SWALLOWED: Rinse mouth. Do not induce vomiting – *immediately call a POISON CENTER or doctor*
- P304+P340 IF INHALED: Remove person to fresh air and keep comfortable for breathing
- P303+P361+P353 IF ON SKIN (or hair): Take off immediately all contaminated clothing. Rinse skin with water/shower
- P305+P351+P338: IF IN EYES: Rinse cautiously with water for several minutes. Remove contact lenses, if present and easy to do. Continue rinsing.

The label on each ampoule includes the following elements:

- all pictograms
- Signal word
- Hazardous components
- Product identifier (at least in part)

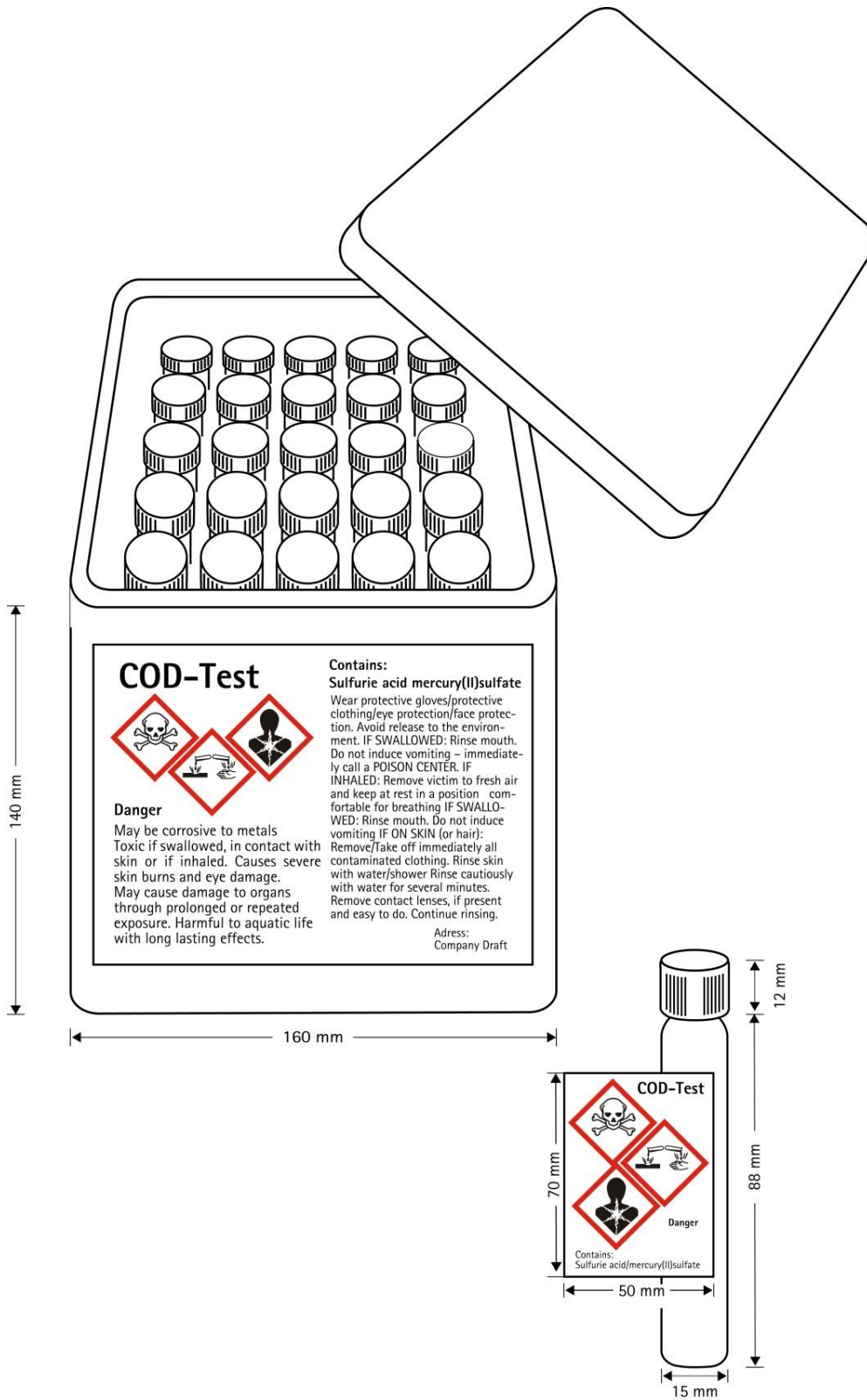



**(b) Different immediate containers which are indicated with a letter on the closure, complete information required is displayed with reference to these letters on the outer of the package: Box containing various reagents**

**(i) Substance/mixture:**

Various reagents in ampoules and small containers

A test box can contain (depending on the test parameter) pre-filled glass ampoules and reagent bottles. The example is the cuvette test for the parameter Organic acids.







**(ii) Use**

Cuvette tests are pre-portioned, ready to use reagents for water analysis. Cuvette test come in a fully equipped box and can be used immediately. Together with photometers and accessories, cuvette tests form a comprehensive and accurate measuring system.

**(iii) Classification**

<i>Component</i>	<i>Hazard class</i>	<i>Hazard class and Category</i>
Cuvette	Acute toxicity	Acute Tox. Cat 4
Solution A	Skin corrosion / irritation	Skin Irrit. Cat 2
	Serious eye damage/ eye irritation	Eye Irrit. Cat 2
Solution B	Skin corrosion / irritation	Skin Irrit. Cat 2
	Skin sensitization	Skin Sens. Cat 1
	Serious eye damage/ eye irritation	Eye Irrit. Cat 2
	Carcinogenicity	Carc. Cat 2
	Hazardous to the aquatic environment	Aquatic acute Cat 1
Solution C	Skin corrosion / irritation	Skin Corr. Cat 1A
Solution D	Skin corrosion / irritation	Skin Irrit. Cat 2
	Serious eye damage/ eye irritation	Eye Dam. Cat 1

**(iv) Full labelling information**

<i>Component</i>	<i>Signal word</i>	<i>Pictogram</i>	<i>Hazard statement</i>	<i>Precautionary statement as assigned in GHS Annex 3, Section 3</i>
Cuvette	Warning		(302) Harmful if swallowed	(280) Wear protective gloves/protective clothing/eye protection/face protection. (302+312) IF SWALLOWED: Call a POISON CENTER or doctor/physician if you feel unwell.
Solution A	Warning		(315) Causes skin irritation (319) Causes serious eye irritation	(280) Wear protective gloves/protective clothing/eye protection/face protection. (302+352) IF ON SKIN: Wash with plenty of soap and water. (305+351+338) IF IN EYES: Rinse cautiously with water for several minutes. Remove contact lenses, if present and easy to do. Continue rinsing. (313) Get medical advice/attention.
Solution B	Warning	  	(315) Causes skin irritation. (317) May cause an allergic skin reaction. (319) Causes serious eye irritation. (351) Suspected of causing cancer. (400) Very toxic to aquatic life.	(273) Avoid release to the environment. (280) Wear protective gloves/protective clothing/eye protection/face protection. (302+352) IF ON SKIN: Wash with plenty of soap and water. (305+351+338) IF IN EYES: Rinse cautiously with water for several minutes. Remove contact lenses, if present and easy to do. Continue rinsing. (308+313) IF exposed or concerned: Get medical advice/attention.
Solution C	Danger		(314) Causes severe skin burns and eye damage.	(280) Wear protective gloves/protective clothing/eye protection/face protection. (303+361+353) IF ON SKIN (or hair): Remove/Take off immediately all contaminated clothing. Rinse skin with water/shower. (305+351+338) IF IN EYES: Rinse cautiously with water for several minutes. Remove contact lenses, if present and easy to do. Continue rinsing. (314) Get medical advice/attention if you feel unwell.

Component	Signal word	Pictogram	Hazard statement	Precautionary statement as assigned in GHS Annex 3, Section 3
Solution D	Danger		(315) Causes skin irritation. (318) Causes serious eye damage.	(280) Wear protective gloves/protective clothing/eye protection/face protection. (302+352) IF ON SKIN: Wash with plenty of soap and water. (305+351+338) IF IN EYES: Rinse cautiously with water for several minutes. Remove contact lenses, if present and easy to do. Continue rinsing. (313) Get medical advice/attention.

(v) **Packaging description and size**

Packaging description:

One test box of Organic acids Cuvette test contains:

- 25 cuvettes with 0,4ml solution each
- 1 bottle solution A with 11ml
- 1 bottle solution B with 11ml
- 1 bottle solution C with 11ml
- 1 bottle solution D with 55ml



Sizes:

Component	Height (mm)	Length (mm)	Width (mm)	Diameter (mm)
Cuvettes	88	----	----	13.3
Bottles A-C (small)	55	31	31	----
Bottle D (big)	97	31	31	----
Cardboard box	118	177	88	----

**(vi) Labelling problems encountered**

The test kits provide an easy way of analysis with a reduced amount of chemistry in comparison to the normal method. Because of this, the reagent containers are very small and it is not possible to fulfil the complete labelling requirements on the immediate containers.

The boxes are closed, when they are delivered, so that the complete information is on the box in several languages with acceptable legibility. Multilingual labelling is preferred because the test kits are supplied in multiple countries. However, multilingual labelling on the immediate containers is almost impossible.

**(vii) Adopted solution**

Cuvette:

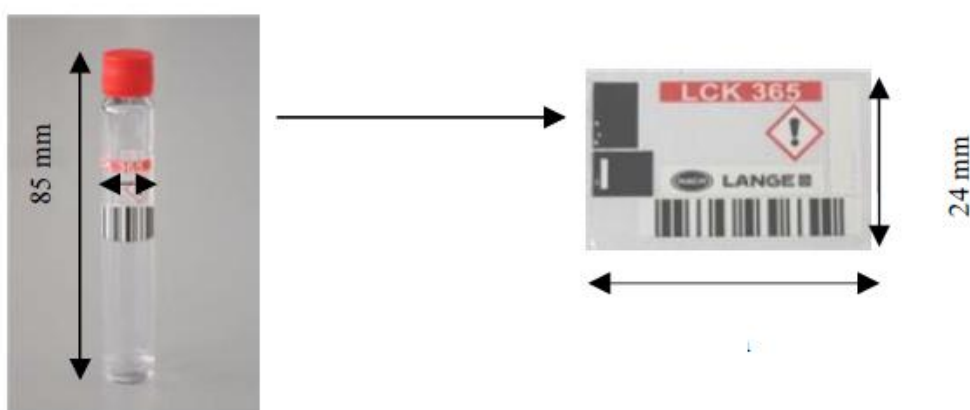

13 mm

Due to analysis needs, only the upper part of the cuvette can be used for labelling. The lower part of the cuvette has to be free for the measurement. Therefore the cuvette label only contains the pictograms (there is space for up to three) and the product identifier. Other labelling elements are not possible because of the very limited label size. This approach also avoids the need for multilingual labels (1.4.10.5.4.4 (b)) where the available label space is very limited. The pictogram shows the important hazard information and is non-lingual. As the cuvette stays in the outer package until the time of immediate use, the information is available to the customer before use.

Small bottles:

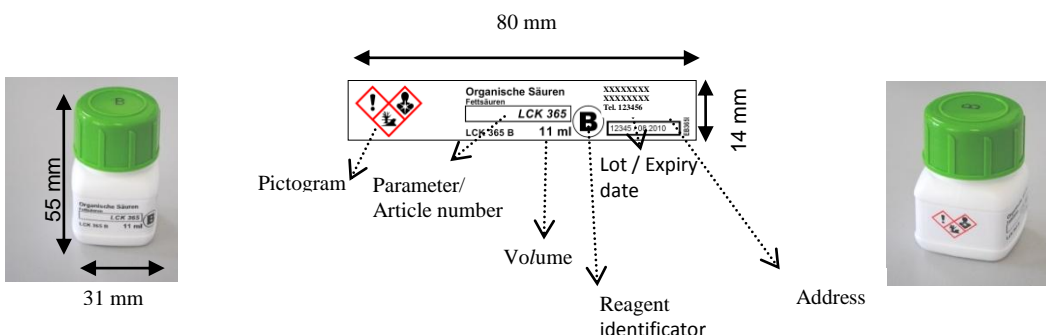

The information provided on the label of the smaller bottles is shown above. There is space for up to five pictograms. This approach avoids the need for multilingual labels where the available label space is very limited (1.4.10.5.4.4 (b)).

Big bottles:

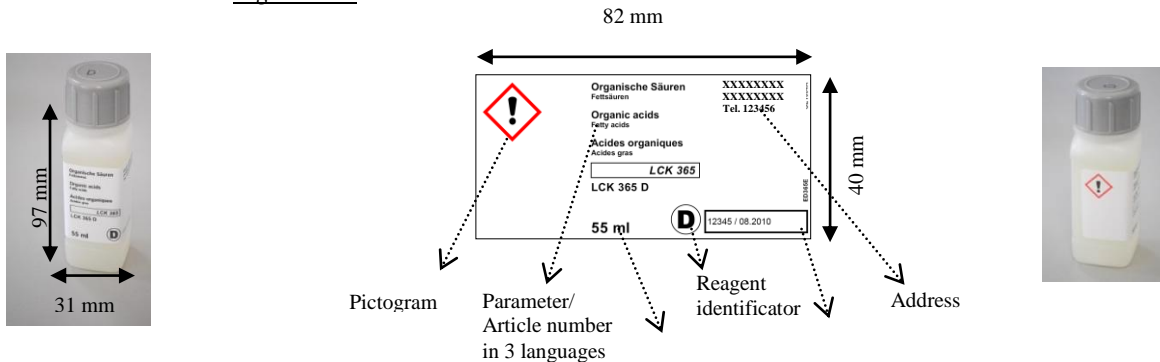

The information provided on the label of the larger bottles is shown above. There is space for up to five pictograms. Again, this approach avoids the need for multilingual labels where the available label space is very limited (1.4.10.5.4.4 (b)).

Cuvette test box:

The test boxes are a combination of outer and inner packaging:



The cardboard box is the outer packaging of the test kit. Each reagent has an identifier which is linked to information about it printed on the box.

For each reagent the pictograms, reagent identifiers, hazardous components, and the H- and P-codes, are provided on the sides of the cardboard box in the necessary languages. All the H- and P-codes and statements are printed on the bottom of the cardboard box, again in all the necessary languages. Therefore, the outer packaging (cardboard box) contains all the GHS label elements for each reagent in the test kit.

Reagents are only supplied in combination in a test kit; they are not supplied individually.

