



Economic and Social Council

Distr.: General
19 August 2011

Original: English

Economic Commission for Europe

Inland Transport Committee

World Forum for Harmonization of Vehicle Regulations

155th session

Geneva, 15–18 November 2011

Item 16.5 of the provisional agenda

Global technical regulation (gtr) No. 9 (Pedestrian safety)

Proposal for developing amendments to gtr No. 9 (Pedestrian safety)

Submitted by the representative from the Netherlands*

The text reproduced below was prepared by the expert from the Netherlands requesting the formal authorization for developing a new amendment to gtr No. 9. It is based on ECE/TRANS/WP.29/GRSP/2011/12 and on Informal documents GRSP-49-09, GRSP-49-18 and GRSP-49-17 distributed during the forty-ninth session of the Working Party on Passive Safety (GRSP) (ECE/TRANS/WP.29/GRSP/49 para. 10). It is distributed to the World Forum for Harmonization of Vehicle Regulations (WP.29) and to the Executive Committee (AC.3) of the 1998 Agreement for consideration.

* In accordance with the programme of work of the Inland Transport Committee for 2010–2014 (ECE/TRANS/208, para. 106 and ECE/TRANS/2010/8, programme activity 02.4), the World Forum will develop, harmonize and update Regulations in order to enhance the performance of vehicles. The present document is submitted in conformity with that mandate.

I. Introduction

1. The objective of this proposal is to clarify the current text of gtr No. 9 on pedestrian safety to prevent misinterpretations and to introduce editorial corrections.
2. The proposal is a consolidated text of ECE/TRANS/WP.29/GRSP/2011/12, Informal documents GRSP-49-09, GRSP-49-18 and GRSP-49-17, tabled by the experts from International Organization of Vehicle Manufacturers (OICA) and Japan, distributed during the forty-ninth session of the Working Party on Passive Safety (GRSP). GRSP agreed that a consolidated text of these proposals for developing an amendment to the gtr, voluntarily prepared by the expert from the Netherlands, would be submitted to the November 2011 sessions of WP.29 and AC.3.

II. Justification of changes

A. Amendments proposed to definitions and test procedures

3. The expert from OICA in Informal document GRSP-48-27, explained that from the Industry's point of view, an interpretation can arise with the current wording used in gtr No. 9 and the draft Regulation (1958 Agreement) on pedestrian safety concerning the use of the first contact point as the main reference point for the head form test procedure. Corrigendum No. 2 to gtr No. 9, made this more obvious for the future application of gtr No. 9 by Contracting Parties to the 1998 Agreement as well as the Regulation to the Contracting Parties of 1958 Agreement.
4. Following the presentation of the document mentioned above, GRSP requested the expert from OICA to further clarify the problem and suggested potential solutions to make the test procedure clearer at the May 2011 GRSP session.
5. From the experiences in applying existing pedestrian safety legislation in Japan and Europe it had been noted that the first contact point may not be appropriate as the main reference point for testing. It is true that a first contact will always be achieved. However, there are points on the bonnet surface that may be identified as being of interest (due to underlying structures, hard points, etc.) but where a direct first contact of this point is impossible due to the bonnet design. Assuming that the main impact energy is transferred in the centre-plane of the impactor that also contains the centre of gravity of the impactor it will nevertheless be possible to test such points, to achieve first contacts in the surrounding area and to allocate test results to such points. Industry feels that this procedure is clearer since it can be used for every point within the borderlines of the test area on the bonnet surface, independent of whether a point can be contacted by the headform during a test or not. Furthermore, the procedure allows a well defined positioning of the impactor while a first contact may be achieved with different points of the impactor's surface. Finally, the procedure will guarantee that vehicles of the same width have an identical width of the test area.
6. This proposal contains the necessary changes to the texts of gtr No. 9 and draft UN Regulation on the headform test as a three-dimensional system of:
 - (a) a measuring point (the point being closest to an underlying structure, to hard points, etc.; is also referred to as test point or impact point);
 - (b) a target point (the point the propelling device targets to; also referred to as aiming point);
 - (c) a first contact point (the point where the initial contact of the impactor with the bonnet surface occurs; also referred to as impact point).

7. In this spatial geometry, the measuring point as well as the target point are always in the centre-plane of the impactor that is aligned to the vertical longitudinal plane of the vehicle. The test result achieved (i.e. an Head Injury Criterion (HIC) value) shall always be allocated to the measuring point, independent of where the first contact occurred.

8. In addition to the three-dimensional definition of the point to be tested, the expert from OICA noted a discrepancy in the headform test area definition: According to the current test procedure described in gtr No 9 and in the draft Regulation, the impact can occur only within the child and/or adult headform test area excluding an offset of 1/2 headform diameter. The calculation of the HIC 1000 or the HIC 1700 zones respectively is nevertheless done for the whole area between the side reference lines. In practice, this could create a situation of possible misinterpretation when assigning the HIC zones to the bonnet surface since it may be possible to assign the less challenging criterion to areas that cannot be tested. The wording proposed with this document provides a clear procedure, i.e. the HIC value is to be calculated only for the area to be tested. Consequently this leads to a smaller HIC 1700 area in total which will contribute to increased safety of pedestrians.

9. This proposal also clarifies the same approach for the legform impactor test geometry of aligning the impactor's centre-plane with the measuring point as described above for the headform impactor.

10. Moreover, the expert from OICA wishes to point out that the changes to the procedures as described above are based on the experiences collected since gtr No. 9 was discussed during the meetings of the former Informal Group on Pedestrian Safety (INF GR PS). In the meantime, several experiences could be collected when testing vehicles to comply with legislation in Japan and Europe as well as with consumer requirements worldwide. The procedures represent common practice in regulatory use. The proposed changes will contribute to the clearness of future worldwide pedestrian protection regulations in order to minimize the room for interpretations when the gtr No. 9 or the draft ECE regulation will enter into force in national legislation of the Contracting Parties.

11. The expert from OICA therefore would appreciate if the changes proposed were accepted by GRSP, WP.29 and AC.3 as soon as possible making test procedures consistent around the world.

B. Definitions, paragraph 3.10.

12. This clarification is based on the content of Commission Regulation (EC) No. 631/2009.

C. General requirements legform test to bumper, paragraph 4.1.

13. Location of lower bumper height measurement is not specified in paragraph 4.1.

14. Therefore for vehicles with the lower bumper height of less than 425 mm and greater than or equal to 500 mm, depending on lateral location, the lack of definition of measurement location may lead to confusion about the choice of test conditions.

15. By adding the above-mentioned wording, the test condition of each test point becomes settled clearly.

16. In addition, these contents are already proposed in the draft Regulation on pedestrian safety (ECE/TRANS/WP.29/2010/127).

**D. Test impactor test specifications, paragraph 6.3.1.1.5., 6.3.1.2.8.,
Lower legform impactor certification 8.1.2.2.,
Upper legform impactor certification 8.2.2.**

17. A term of "Certification" is used in the title of paragraph for certification procedures, "8. CERTIFICATION OF IMPACTORS". A term of "Certification" shall be used in subparagraphs and related paragraphs.

III. Proposed amendments

In the text of the regulation (part B)

Paragraph 2.1., the reference to footnote 2 and footnote 2, correct as footnote 1

Paragraph 3.1., amend to read:

"3.1. *"Adult headform test area"* is an area on the outer surfaces of the front structure. The area is bounded, ~~in the front, by a wrap around distance (WAD) of 1,700 mm and, at the rear, by the rear reference line for adult headform and, at each side, by the side reference line.~~

- (a) **in the front, by a wrap around distance (WAD) of 1,700 or a line 82.5 mm rearward of the bonnet leading edge reference line, whichever is most rearward at a given lateral position,**
- (b) **at the rear, by a WAD 2,100 or a line 82.5 mm forward of the bonnet rear reference line, whichever is most forward at a given lateral position, and**
- (c) **at each side, by a line 82.5 mm inside the side reference line.**

The distance of 82.5 mm is to be set with a flexible tape held tautly along the outer surface of the vehicle."

Paragraph 3.10., amend to read:

"3.10. *"Bumper test area"* means the frontal surface of the bumper limited by two longitudinal vertical planes intersecting the ~~corners of the bumper and moved 66 mm parallel and inboard of the corners of the bumpers~~ **points 66 mm inside the defined corners of the bumper. This distance is to be set with a flexible tape held tautly along the outer surface of the vehicle."**

Paragraph 3.12., amend to read:

"3.12. *"Child headform test area"* is an area on the outer surfaces of the front structure. The area is bounded, ~~in the front, by the front reference line for child headform, and, at the rear, by the WAD1700 line, and by the side reference lines.:~~

- (a) **in the front, by a WAD 1,000 or a line 82.5 mm rearward of the bonnet leading edge reference line, whichever is most rearward at a given lateral position,**
- (b) **at the rear, by a WAD 1,700 or a line 82.5 mm forward of the bonnet rear reference line, whichever is most forward at a given lateral position, and**
- (c) **at each side, by a line 82.5 mm inside the side reference line.**

The distance of 82.5 mm is to be set with a flexible tape held tautly along the outer surface of the vehicle."

Paragraph 3.19., amend to read:

"3.19. ~~"Impact~~ **First contact point**" means the point on the vehicle where initial contact by the test impactor occurs. The proximity of this point to the target point is dependent upon both the angle of travel by the test impactor and the contour of the vehicle surface (see point C B in Figure 6B and Figure 6C)."

[The first contact point is sometimes also referred to as "impact point" in respective regular texts for pedestrian protection.]

Paragraph 3.25., amend to read:

"3.25. **Target point**" means the intersection of the projection of the headform longitudinal axis with the front surface of the vehicle (see point A in Figure 6A)."

[The target point is sometimes also referred to as "aiming point" in respective regular texts for pedestrian protection.]

Insert new paragraphs 3.30. to 3.32., to read:

"3.30. **The measuring point for the headform test is a point in the vertical longitudinal plane of the vehicle, containing the centre of the impactor. In this plane, it is the point at which the impactor nominally first contacts the bonnet top (see point B in Figure 6A and Figure 6B). The first contact point may differ from the measuring point as a result of the geometry of the bonnet top.**"

[The measuring point is sometimes referred to as "test point" or "selected impact point" in respective regulatory texts for pedestrian protection.]

3.31. **The measuring point for the lower legform to bumper test and upper legform to bumper test lies in a vertical longitudinal plane containing the central axis of the impactor. The first contact point may differ from the measuring point as a result of the geometry of the vehicle front.**"

3.32. **"Bonnet top test area" is composed of the child headform test area and the adult headform test area as defined in Paragraph 3.12 and 3.1 respectively.**"

Figure 6, shall be deleted

Insert new Figures 6A to 6C, to read:

"Figure 6A

Measuring and target point in the vertical longitudinal plane through the center of the impactor (see paragraphs 3.30. and 3.25.)²

Measuring and target point

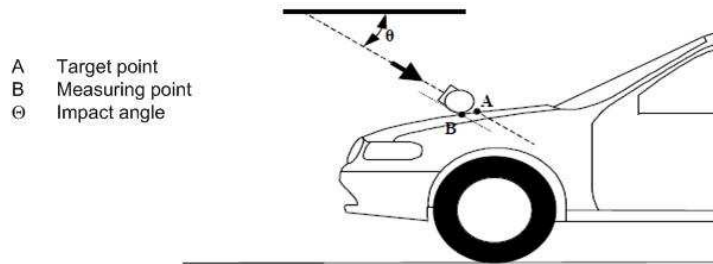
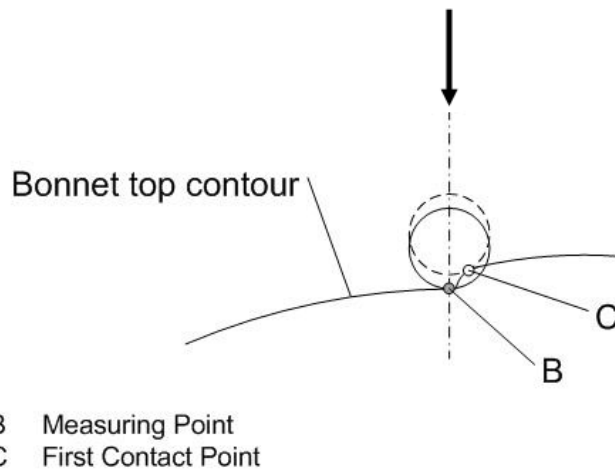

Figure 6B

Measuring and first contact point (see paragraphs 3.30. and 3.19.)²
(schematic front view)



² Remark: due to the spatial geometry of the bonnet top, the first contact point C does, in most cases, not lie in the same vertical longitudinal or transverse plane which contains measuring point B.

Figure 6C
Measuring and first contact point (see paragraphs 3.31. and 3.19.)
Geometry of a Lower/Upper legform to bumper impact (top view)

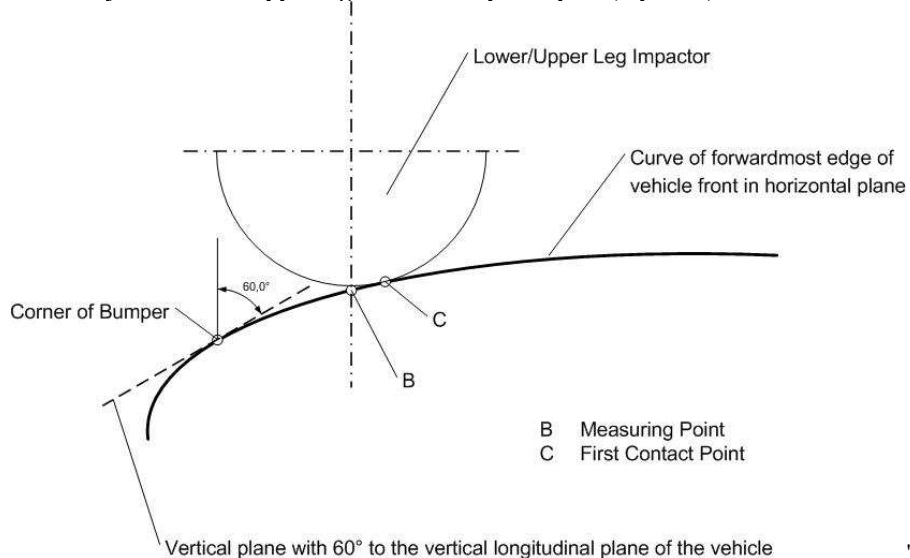

Paragraph 4.1., amend to read:

"4.1. *Legform test to bumper*

For vehicles with a lower bumper height **at the test position** of less than 425 mm, the requirements of paragraph 4.1.1. shall be applied.

For vehicles with a lower bumper height **at the test position** which is greater than or equal to 425 mm and less than 500 mm, the requirements of either paragraph 4.1.1. or 4.1.2., at the choice of the manufacturer, shall be applied.

For vehicles with a lower bumper height **at the test position** of greater than, or equal to 500 mm, the requirements of paragraph 4.1.2. shall be applied."

Paragraph 5.2.3., amend to read:

"5.2.3. The HIC recorded shall not exceed 1,000 over a minimum of one half of the child headform test area and 1,000 over two thirds of the **bonnet top test area** ~~combined child and adult headform test areas~~. The HIC for the remaining areas shall not exceed 1,700 for both headforms.

In case there is only a child headform test area, the HIC recorded shall not exceed 1,000 over two thirds of the test area. For the remaining area the HIC shall not exceed 1,700."

Paragraph 5.2.4.1., amend to read:

"5.2.4.1. The manufacturer shall identify the zones of the bonnet top **test area** where the HIC must not exceed 1,000 (HIC1000 Zone) or 1,700 (HIC1700 Zone) (see Figure 11)"

Figure 11(former), shall be deleted

Insert new Figure 11, to read:

"Figure 11

Example of marking of HIC1000 zone and HIC1700 zone

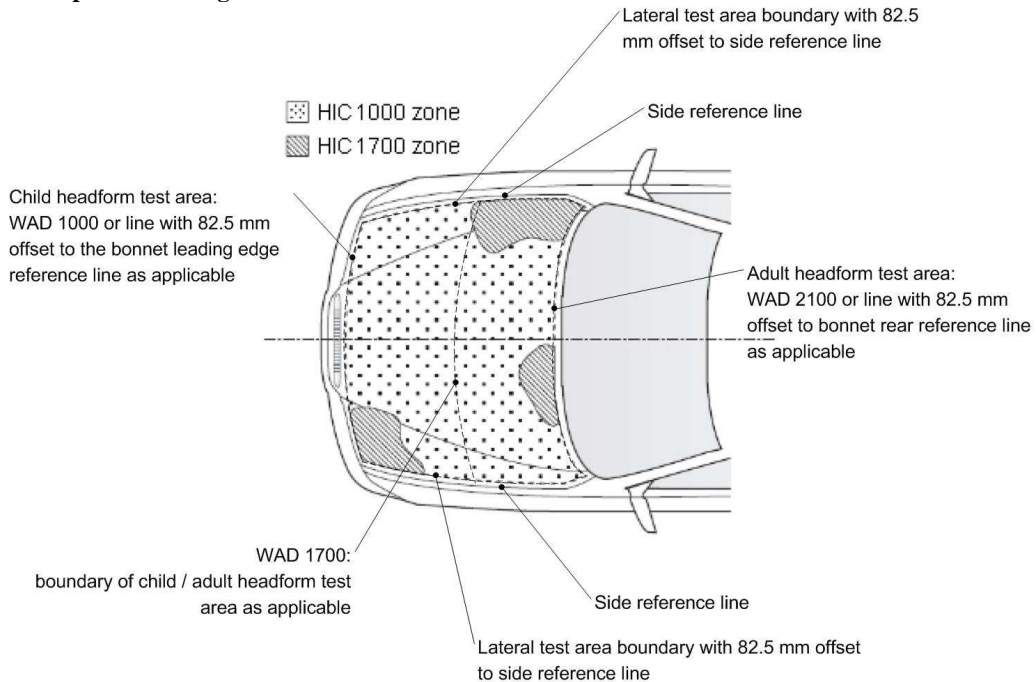

Paragraph 5.2.4.3., amend to read:

"5.2.4.3. The areas of "HIC1000 zone" and "HIC1700 zone" may consist of several parts, with the number of these parts not being limited. The determination of the impacted zone is done by the **measuring first contact point, irrespective of the position of the first contact point of the headform** with the "bonnet top"."

Paragraph 5.2.4.4., amend to read:

"5.2.4.4. The calculation of the surface of the **bonnet top test impact** area as well as the surface areas of "HIC1000 zone" and "HIC1700 zone" shall be done on the basis of a projected bonnet when viewed from a horizontal plane parallel to the horizontal zero plane above the vehicle, on the basis of the drawing data supplied by the manufacturer."

Paragraph 6.3.1.1.5., amend to read:

"6.3.1.1.5. The test impactor or at least the foam flesh shall be stored during a period of at least four hours in a controlled storage area with a stabilized humidity of 35 percent \pm 15 percent and a stabilized temperature of 20 \pm 4°C prior to impactor removal for **calibration certification**. After removal from the storage the impactor shall not be subjected to conditions other than those pertaining in the test area."

Paragraph 6.3.1.2.8., amend to read:

"6.3.1.2.8. The test impactor or at least the foam flesh shall be stored during a period of at least four hours in a controlled storage area with a stabilized humidity of 35 percent \pm 15 percent and a stabilized temperature of 20 ± 4 °C prior to impactor removal for ~~calibration~~ **certification**. After removal from the storage the impactor shall not be subjected to conditions other than those pertaining in the test area."

Paragraph 7.1.1.1., amend to read:

"7.1.1.1. The selected **measuring target** points shall be in the bumper test area."

Paragraph 7.1.1.3.3., amend to read:

"7.1.1.3.3. ~~At the time of first contact the centre line of the impactor shall be within a ± 10 mm tolerance to the selected impact location.~~ **For lower leg testing, an impact tolerance of ± 10 mm shall apply.**"

Paragraphs 7.1.2.1. and 7.1.2.2., amend to read:

"7.1.2.1. The selected **measuring target** points shall be in the bumper test area as defined in paragraph 3.10."

7.1.2.2. The direction of impact shall be parallel to the longitudinal axis of the vehicle, with the axis of the upper legform vertical at the time of first contact. The tolerance to this direction is $\pm 2^\circ$.

At the time of first contact the impactor centre line shall be vertically midway between the upper bumper reference line and the lower bumper reference line with a ± 10 mm tolerance and the impactor vertical centre line shall be positioned laterally ~~with the selected impact location~~ with a tolerance of ± 10 mm."

Paragraph 7.2.3., amend to read:

"7.2.3. Recording

The acceleration time histories shall be recorded, and HIC shall be calculated. The ~~first~~ **measuring** point of contact on the front structure of the vehicle shall be recorded. Recording of test results shall be in accordance with ISO 6487:2002."

Paragraphs 7.3.2. and 7.3.3., amend to read:

"7.3.2. No **measuring impact** point shall be located so that the impactor will impact the test area with a glancing blow resulting in a more severe second impact outside the test area.

The selected **measuring impact** points on the bonnet for the child headform impactor shall be ~~at the time of first contact~~: **within the child headform test area as defined in 3.12.**

- (a) ~~A minimum of 82.5 mm inside the defined side reference lines, and;~~
- (b) ~~Forward of the WAD1700 line or a minimum of 82.5 mm forward of the bonnet rear reference line, whichever is most forward at the point of measurement, and~~
- (c) ~~Rearward of the WAD1000 line, or a minimum of 82.5 mm rearward of the bonnet leading edge reference line, whichever is most rearward at the point of measurement.~~

~~These minimum distances are to be set with a flexible tape held tautly along the outer surface of the vehicle."~~

- 7.3.3. ~~The point of first contact point of the headform impactor shall be within a ± 10 mm tolerance to the selected impact expected first contact point. For head impact testing, an impact tolerance of ± 10 mm shall apply."~~

Paragraphs 7.4.2. and 7.4.3., amend to read:

- "7.4.2. No **measuring impact** point shall be located so that the impactor will impact the test area with a glancing blow resulting in a more severe second impact outside the test area.

The selected **measuring impact** points on the bonnet for the adult headform impactor shall be ~~at the time of first contact:~~ **within the adult headform test area as defined in 3.1.**

- (a) ~~A minimum of 82.5 mm inside the defined side reference lines, and;~~
- (b) ~~Forward of the WAD1700 line or a minimum of 82.5 mm forward of the bonnet rear reference line, whichever is most forward at the point of measurement, and~~
- (c) ~~Rearward of the WAD1000 line, or a minimum of 82.5 mm rearward of the bonnet leading edge reference line, whichever is most rearward at the point of measurement.~~

~~These minimum distances are to be set with a flexible tape held tautly along the outer surface of the vehicle."~~

- 7.4.3. ~~The point of first contact point of the headform impactor shall be within a ± 10 mm tolerance to the selected impact expected first contact point." For head impact testing, an impact tolerance of ± 10 mm shall apply."~~

Paragraphs 8.1.2.2 to 8.1.2.2.4., amend to read:

"8.1.2.2. **Calibration Certification**

- 8.1.2.2.1. The foam flesh for the test impactor shall be stored during a period of at least four hours in a controlled storage area with a stabilized humidity of 35 ± 10 percent and a stabilized temperature of $20 \pm 2^\circ\text{C}$ prior to impactor removal for **calibration certification**. The test impactor itself shall have a temperature of $20^\circ \pm 2^\circ\text{C}$ at the time of impact. The temperature tolerances for the test impactor shall apply at a relative humidity of 40 ± 30 percent after a soak period of at least four hours prior to their application in a test.

- 8.1.2.2.2. The test facility used for the **calibration certification** test shall have a stabilized humidity of 40 ± 30 percent and a stabilized temperature of $20 \pm 4^\circ\text{C}$ during **calibration certification**.

- 8.1.2.2.3. Each **calibration certification** shall be completed within two hours of when the impactor to be **calibrated certified** is removed from the controlled storage area.

- 8.1.2.2.4. Relative humidity and temperature of the **calibration certification** area shall be measured at the time of **calibration certification** and recorded in a **calibration certification** report."

Paragraphs 8.2.2.to 8.2.2.4., amend to read:

"8.2.2. **Calibration Certification**

- 8.2.2.1. The foam flesh for the test impactor shall be stored during a period of at least four hours in a controlled storage area with a stabilized humidity of 35 ± 10

per cent and a stabilized temperature of $20^{\circ} \pm 2^{\circ}\text{C}$ prior to impactor removal for ~~calibration~~ **certification**. The test impactor itself shall have a temperature of $20^{\circ} \pm 2^{\circ}\text{C}$ at the time of impact. The temperature tolerances for the test impactor shall apply at a relative humidity of 40 ± 30 per cent after a soak period of at least four hours prior to their application in a test.

- 8.2.2.2. The test facility used for the ~~calibration~~ **certification** test shall have a stabilized humidity of 40 ± 30 percent and a stabilized temperature of $20^{\circ} \pm 4^{\circ}\text{C}$ during ~~calibration~~ **certification**.
- 8.2.2.3. Each ~~calibration~~ **certification** shall be completed within two hours of when the impactor to be ~~calibrated~~ **certified** is removed from the controlled storage area.
- 8.2.2.4. Relative humidity and temperature of the ~~calibration~~ **certification** area shall be measured at the time of ~~calibration~~ **certification**, and recorded in a ~~calibration~~ **certification** report."
-