

## Supplement to the proposal for 03 series of amendments to Regulation No. 95

The text reproduced below was prepared by the expert from France in order to extend the scope of the present Regulation to all kinds of power train systems above a certain working voltage level. The modifications to the existing text of the Regulation R 95 are based on informal document No. GRSP- 46-04, distributed during the forty sixth session of the Working Party on Passive Safety (GRSP) and discussions made at the 3<sup>rd</sup> EVPC adhoc group meeting held in Bonn, 11-12 march 2010, respectively. This informal document supersedes document ECE/TRANS/WP.29/GRSP/2010/21 distributed as an official document for the forty-seventh session of the Working Party on Passive Safety (GRSP). The modifications to the existing text of Regulation No. 95 are originally marked in bold or strikethrough characters and the modifications resulting from the EVPC meeting are highlighted in grey colour.

Additional amendments and corrections were introduced for clarification to take into account remarks received, in order to have one consolidated document. Modifications to the existing text GRSP 47-03/Rev.1 are deleted or marked in italic characters and highlighted in grey colour. Additional justifications are provided at the end of the document.

### I. Proposal

Contents,

Insert a new Annex 9, to read:

“... ”

**Annex 9 - Test Procedures for the protection of the occupants of vehicles operating on electrical power from high voltage and electrolyte spillage.**

~~Appendix 1 – Protection against direct contacts of parts under voltage”~~

Appendix 1 – Jointed Test Finger (IPXXB)”

Paragrah 2.2.4., amend to read:

“2.2.4. The siting of the engine (front, rear or centre) and the orientation (transversal or longitudinal) of the engine, in so far as they have a negative effect on the result of the impact test of this Regulation.”

Insert new paragraph 2.2.8., to read

“2.2.8. ~~The place of the rechargeable energy storage system (RESS)”~~

The locations of the RESS, in so far as they have a negative effect on the result of the impact test prescribed in this Regulation.”

Modify paragraph 2.3, to read:

“2.3. **Passenger compartment”**

Insert a new paragraph 2.3.1., to read:

Formatted: Underline

Formatted: Indent: Before: 2 cm, Hanging: 1.97 cm

Formatted: Font: Bold, Complex Script Font: Not Bold

“2.3.1. “Passenger compartment with regard to occupant protection” means the space for occupant accommodation, bounded by the roof, floor, side walls, doors, outside glazing and front bulkhead and the plane of the rear compartment bulkhead or the plane of the rear-seat back support.” ~~For the sake of protection of occupants from high voltage and electrolyte spillage according to Annex 11 a different definition (see paragraph 2.32.) is applied.”~~

Insert a new paragraph 2.3.2., to read:

“2.3.2. “Passenger compartment for electric safety assessment” means the space for occupant accommodation, bounded by the roof, floor, side walls, doors, outside glazing, front bulkhead and rear bulkhead, or rear gate, as well as by the electrical protection barriers and enclosures provided for protecting the power train from direct contact with high voltage live parts.”

Insert new paragraphs 2.15. to 2.34., to read:

2.30.2.15. “High Voltage” means the classification of an electric component or circuit, if its ~~working voltage is > 60 V and ≤ 1500 V~~ direct current (DC) or > 30 V and ≤ 1000 V alternating current (AC) root – mean – square (rms),

2.16. “Rechargeable energy storage system (RESS)” means the rechargeable energy storage system ~~that~~ which provides the electrical energy for propulsion,

2.28.2.17. [“Electrical Protection Barrier” / Protection Shielding / Shielding / Barrier-el/ High Voltage Protection] means the part providing protection against any direct contact to the high voltage live parts ~~from any direction of access.~~

2.15.2.18. “Electrical power train” means the electrical circuit which includes the traction motor(s), and may also include the RESS, the electrical energy conversion system, the electronic converters, the associated wiring harness and connectors, and the coupling system for charging the RESS,

2.21.2.19. “Live parts” means conductive part(s) intended to be electrically energized in normal use,

2.24.2.20. “Exposed conductive part” means the conductive part which can be touched under the provisions of the protection degree IPXXB, and which becomes electrically energized under isolation failure conditions,

2.20.2.21. “Direct contact” means the contact of persons with high voltage live parts,

2.22.2.22. “Indirect contact” means the contact of persons with exposed conductive parts,

2.23.2.23. “Protection IPXXB degree” means the protection from contact with high voltage live parts provided by either an electrical protection barrier or an enclosure related to the contact with live parts by a test probe, such as a and tested using a Jointed Test Finger (IPXXB) or a test wire (IPXXD) as described ~~defined in Appendix 1~~ paragraph 4 of Annex 9,

2.26.2.24. “Working voltage” means the highest value of an electrical circuit voltage root-mean-square (rms), specified by the manufacturer, which

Deleted: 3

Deleted: 2.15.2.18. “Electrical power train” means the electrical circuit which includes the traction motor(s), and may also include the RESS, the electrical energy conversion system, the electronic converters, the associated wiring harness and connectors, and the coupling system for charging the RESS,

Formatted: Complex Script  
Font: Bold, Italic

may occur between any conductive parts in open circuit conditions or under normal operating conditions. If the electrical circuit is divided by galvanic isolation, the working voltage is defined for each divided circuit, respectively.

2.19.2.25. “Coupling system for charging the rechargeable energy storage system (RESS)” means the electrical circuit used for charging the RESS from an external electrical power supply including the vehicle inlet,

2.27.2.26. “Electrical chassis” means a set made of conductive parts electrically linked together, whose electrical potential is taken as reference,

2.25.2.27. “Electrical circuit” means an assembly of connected high voltage live parts which is designed to be electrically energized in normal operation,

2.17.2.28. “Electrical energy conversion system” means a system (e.g. fuel cell) that generates and provides electrical energy for electrical propulsion,

2.18.2.29. “Electronic converter” means a device capable of controlling and/or converting electrical power for electrical propulsion,

2.29.2.30. “Enclosure” means the part enclosing the internal units and providing protection against any direct contact from any direction of access,

2.31. “High Voltage Bus” means the electrical circuit, including the coupling system for charging the RESS that operates on a high voltage,

2.33.32. “Solid insulator” means the insulating coating of wiring harnesses, provided in order to cover and prevent protect the high voltage live parts against from any direct contact from any direction of access. This includes covers for insulating the high voltage live parts of connectors, and varnish or paint for the purpose of insulation,

2.33. “Automatic disconnect” means a device that when triggered, galvanically separates the electrical energy sources from the rest of the high voltage circuit of the electrical power train,”

2.34. “Open type traction battery” means a type of battery requiring liquid and generating hydrogen gas released to the atmosphere.”

Insert a new paragraph 3.2.6., to read:

“3.2.6. A general ~~General~~ description of the ~~RESS~~ electrical power source type, and ~~location~~ and the electrical power train (e.g. hybrid, electric).”

Paragraph 5.2., amend to read:

“5.2. Performance criteria

Additionally, vehicles equipped with electric power train shall meet the requirements of paragraph 5.3.6. in addition. This can ~~could be demonstrated in~~ met by a separate ~~crash~~ impact test at the request of the manufacturer and after validation by the Technical Service, given provided that the electrical components do not influence the occupant protection performance of the vehicle type as defined in paragraphs 5.2.1. to 5.3.4. of this Regulation. In case of this condition the requirements of paragraph 5.3.6 shall be checked in accordance with the methods set out in annex 4 to this Regulation, except paragraphs 6, 7 and Appendix 1 and 2. But the side-impact dummy shall be installed in the front seat on the impact side.”

Formatted: Font: (Utiliser une police de caractè

Deleted: 2.19.2.25. “Coupling system for charging the rechargeable energy storage system (RESS)” means the electrical circuit used for charging the RESS from an external electrical power supply including the vehicle inlet,¶ 2.20.2.21. “Direct contact” means the contact of persons with high voltage live parts,¶ 2.24.2.19. “Live parts” means conductive part(s) intended to be electrically energized in normal use,¶ 2.22.2.22. “Indirect contact” means the contact of persons with exposed conductive parts,¶ 2.23.2.23. “Protection IPXXB degree” means the protection from contact with high voltage live parts provided by either an electrical protection barrier or an enclosure related to the contact with live parts by a test probe, such as a and tested using a Jointed Test Finger (IPXXB) or a test wire (IPXXD) as described defined in Appendix 1 paragraph 4 of Annex 9,¶ 2.24.2.20. “Exposed conductive part” means the conductive part which can be touched under the provisions of the protectio... [1]

Deleted: 2.30.2.15. “High Voltage” means the classification of an electric component or circuit, if its working volt... [2]

Deleted: |

Formatted: Indent: Before: 1.9 cm, Hanging: 2.06 cm

Formatted: Font: 10 pt, Complex Script Font: 10 pt

Deleted: “Open type traction battery” means a liquid type battery requiring refilling with water and generating hyd... [3]

Formatted: Font: 10 pt, Complex Script Font: 10 pt

Formatted: Font: 10 pt, Complex Script Font: 10 pt

Formatted: English U.S.

Deleted: Additionally, vehicles equipped with electric power train shall meet the requirements of paragraph 5.3.6. in addition... [4]

Deleted: ¶

Formatted: Font: Times New Roman

Insert new paragraphs 5.3.6. to 5.3.6.3., to read:

“5.3.6. Following the test conducted in accordance with the procedure defined in Annex 4 to this Regulation, the electrical power train operating on high voltage, and as well as the high voltage components and systems, which are galvanically connected to the high voltage bus of the electric power train, shall meet the following requirements:

Deleted: T

5.3.6.1. Protection against electrical shock

After the impact at least one of the ~~four following~~ criteria specified in paragraph 5.3.6.1.1 through paragraph 5.3.6.1.4.2. shall be met.

If the vehicle has an automatic disconnect function, or device(s) that galvanically divide the electric power train circuit during driving condition, at least one of the following criteria shall apply to the disconnected circuit or to each divided ~~portion~~ circuit individually after the disconnect function is activated.

However criteria defined in 5.3.6.1.4 shall not apply if more than a single potential of a part of the high voltage bus is not protected under the conditions of protection IPXXB.

In the case that the test is performed under the condition that part(s) of the high voltage system are not energized, the protection against electrical shock shall be proved by either 5.3.6.1.3 or 5.3.6.1.4 for the relevant part(s).

5.3.6.1.1. Absence of high voltage

The voltages  $V_b$ ,  $V_1$  and  $V_2$  of the high voltage buses shall be equal or less than 30 VAC or 60 VDC as specified in Annex 9 paragraph 2.

5.3.6.1.2. Low electrical energy

The total energy ~~Energy~~ (TE) on the high voltage buses shall be less than ~~2.0 Joules~~ when measured according to the test procedure as specified in Annex 9 paragraph 3 formula (a). Alternatively the total energy (TE) may be calculated by the measured voltage  $V_b$  of the high voltage bus and the capacitance of the X-capacitors ( $C_x$ ) specified by the manufacturer according to Annex 9 paragraph 3 formula (b).

Deleted: [0.

Deleted: in

The energy stored in the Y-capacitors ( $TE_{y1}$ ,  $TE_{y2}$ ) shall also be less than ~~2.0~~ Joules. This shall be calculated by measuring the voltages  $V_1$  and  $V_2$  of the high voltage buses and the electrical chassis, and the capacitance of the Y-capacitors specified by the manufacturer, according to Annex 9 paragraph 3 formula (c).

Deleted: [0.

Deleted: ]

Deleted: in

Deleted:

5.3.6.1.3. Physical protection

For protection against direct contact with ~~of~~ high voltage live parts, the protection ~~degree~~ IPXXB shall be provided.

In addition, for protection against electrical shock which could arise from indirect contact, the resistance between all exposed conductive parts and the electrical chassis shall be lower than 0.1 ohm when there is current flow of at least 0.2 amperes.

This requirement is satisfied if the galvanic connection has been ~~established~~ made by welding.

5.3.6.1.4. Isolation resistance

The criteria specified in the paragraphs 5.3.6.1.4.1 and 5.3.6.1.4.2 below shall be met.

The measurement shall be conducted in accordance with Annex 9 paragraph 5.

5.3.6.1.4.1. Electrical power train consisting of separate DC- or AC-buses.

If the AC high voltage buses and the DC high voltage buses are galvanically isolated from each other, isolation resistance between the high voltage bus and the electrical chassis (R<sub>i</sub>, as defined in annex 9 paragraph 5) shall have a minimum value of 100 Ω/volt of the working voltage for DC buses, and a minimum value of 500 Ω/volt of the working voltage for AC buses.

5.3.6.1.4.2. Electrical power train consisting of combined DC- and AC-buses

If the AC high voltage buses and the DC high voltage buses are galvanically connected isolation resistance between the high voltage bus and the electrical chassis (R<sub>i</sub>, as defined in annex 9 paragraph 5) shall have a minimum value of 500 Ω/volt of the working voltage.

However, if the protection degree IPXXB is satisfied for all AC high voltage buses or the AC voltage is equal or less than 30 V after the vehicle impact crash, the isolation resistance between the high voltage bus and the electrical chassis (R<sub>i</sub>, as defined in annex 9 paragraph 5) shall have a minimum value of 100 Ω/volt of the working voltage.

5.3.6.2. Electrolyte spillage

In the period from the impact until 30 minutes after no electrolyte from the RESS shall spill into the passenger compartment, and no more than 7 per cent with a maximum of 5.0 liters of electrolyte shall spill from the RESS except open type traction batteries outside the passenger compartment. For open type traction batteries no more than 7 per cent with a maximum of 5.0 liters shall spill outside the passenger compartment.

The manufacturer shall demonstrate compliance in accordance with Annex 9 paragraph 6.

5.3.6.3. RESS retention

RESS located inside the passenger compartment shall remain in the location in which they are installed and RESS components shall remain inside RESS boundaries.

No part of any RESS that is located outside the passenger compartment for electric safety assessment shall enter the passenger compartment during or after the impact test procedures.

The manufacturer shall demonstrate compliance in accordance with Annex 9 paragraph 7.”

Deleted: Electrolyte spillage  
In the period from the impact until 30 minutes after, no electrolyte from the RESS shall spill into the passenger compartment, and no more than 7 per cent with a maximum of 5.0 liters of electrolyte shall spill from the RESS outside the passenger compartment. If the electrolyte spillage mixes with other fluids leaking from the vehicle and the liquids cannot be clearly distinguished the total leakage shall be considered electrolyte spillage.

Paragraph 10., insert new paragraphs 10.6. to 10.9., to read:

**10. TRANSITIONAL PROVISIONS**

10.1 As from ....

10.5 .....02 series of amendments.

10.6. As from the official date of entry into force from the 03 series of amendments, no Contracting Party applying this Regulation shall refuse to grant ECE approval under this Regulation as amended by the 03 series of amendments.

10.7. As from [24][36] months, Contracting Parties applying this Regulation shall grant ECE approvals only to those types of vehicles which comply with the requirements of this Regulation as amended by the 03 series of amendments.

Deleted: ....

10.8. Contracting Parties applying this Regulation shall not refuse to grant extensions of approval to the preceding series of amendments to this Regulation for vehicle types to which the requirements of the 03 series of amendments do not apply.

Deleted: |

10.9. Contracting Parties applying this Regulation shall continue to grant approvals to those types of vehicles which comply with the requirements of this Regulation as amended by the preceding series of amendments during the 36 months' period which follows the date of entry into force of the 03 series of amendments."

10.9. Contracting Parties may continue to apply the requirements with regard to electrical safety in the event of a lateral collision already in force for the categories that are not covered in this Regulation at the time of acceding to 03 series of amendments." ]

Annex 1.

Communication.

Insert a new paragraph 7, to read:

"7. **Location of the electric power source.....**"

Paragraphs 7 to 15 (former), renumber as paragraphs 8 to 16.

Annex 2. amend to read:

**“ARRANGEMENTS OF THE APPROVAL MARK**

Model A

(See paragraph 4.5. of this Regulation)

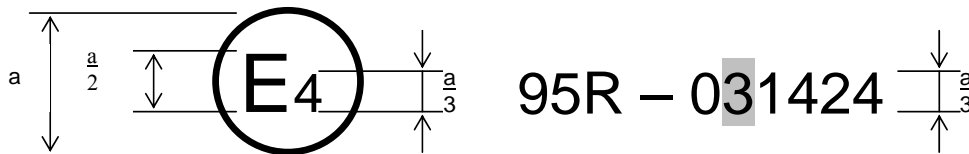

a = 8 mm min.

The above approval mark affixed to a vehicle shows that the vehicle type concerned has, with regard to the protection of the occupants in the event of a frontal collision, been approved in the Netherlands (E4) pursuant to Regulation No. 94 under approval number 04031424. The approval number indicates that the approval was granted in accordance with the requirements of Regulation No. 95 as amended by the 0403 series of amendments.

Model B  
(See paragraph 4.6. of this Regulation)

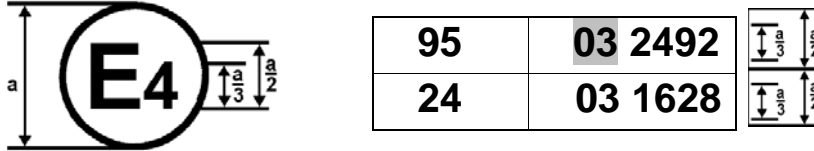

a = 8 mm min.

The above approval mark affixed to a vehicle shows that the vehicle type concerned has been approved in the Netherlands (E4) pursuant to Regulations Nos. 95 and 24. <sup>1/</sup> The first two digits of the approval numbers indicate that, at the dates when the respective approvals were granted, Regulation No. 95 incorporated the ~~04~~03 series of amendments and Regulation No. 24 incorporated the ~~02~~03 series of amendments.”

Annex 4.

Paragraph 4.1., amend to read:

“4.1. General specification

The test vehicle ... of the test.

~~At the request of the manufacturer it shall be allowed to perform the test with the engine or electric energy conversion system running and to allow for the fuel system to be modified in such a way that an appropriate amount of fuel can be used.~~

It shall be allowed by agreement between manufacturer and Technical Service to modify the fuel system so that an appropriate amount of fuel can be used to run the engine or the electrical energy conversion system.”

Paragraph 4.3.2., amend to read:

“4.3.2. The fuel tank shall be filled with water to a mass equal to 90 per cent of the mass of a full load of fuel as specified by the manufacturer **with a tolerance of ± 1 per cent.**

~~Alternative gas (i.e. helium gas) or alternative liquid (i.e. liquid nitrogen (LN2)) can be used instead of hydrogen gas or liquid hydrogen.~~

~~However the requirement of paragraph 5.2.8.1.3. shall be satisfied for the hydrogen conversion system disconnected by its automatic disconnect when this alternative is used.~~

This requirement does not apply to Hydrogen fuel tanks.”

<sup>1/</sup> The latter number is given only as an example.



Insert new paragraphs 5.11. to 5.11.2., to read:

**“5.11. Electrical power train adjustment**

**5.11.1. The RESS shall be at any state of charge, which allows the normal operation of the power train as recommended by the manufacturer.**

**5.11.2. ~~The high voltage system shall be energized.~~The electrical power train shall be energized with or without the operation of the original electrical energy sources (e.g. engine-generator, RESS or electric energy conversion system), however:**

**5.11.2.1. by the agreement between Technical Service and manufacturer it shall be permissible to perform the test with all or parts of the electrical power train not being energized insofar as there is no negative influence on the test result. ~~In this case~~For parts of the electrical power train not energized, the protection against electrical shock shall be proved by either physical protection or isolation resistance for relevant part(s) and appropriate additional evidence.**

**5.11.2.2. in the case where an automatic disconnect is provided, at the request of the manufacturer it shall be permissible to perform the test with the automatic disconnect being triggered. In this case it shall be demonstrated that the automatic disconnect would have operated during the impact test. This includes the automatic activation signal as well as the galvanic separation considering the conditions as seen during the impact.”**

Insert a new Annex 9 and Appendix 1, to read:

**“Annex 9**

**Test Procedures for the ~~P~~rotection of the occupants of vehicles operating on electrical power ~~against / from~~ high voltage and electrolyte spillage**

**This section describes test procedures to demonstrate compliance to the electrical safety requirements of paragraph 5.2.8. For example, megohmmeter or oscilloscope measurements are an appropriate alternative to the procedure described below for measuring isolation resistance. *In this case it may be necessary to deactivate the on-board isolation resistance monitoring system.***

**~~The following procedures should be performed for each of the specified crash tests.~~**

**Before the vehicle ~~impact-crash test conducted,~~ ~~measure and record~~ the high voltage bus voltage (Vb) (see figure 1) shall be measured and recorded to ~~and confirm that it is~~ within the operating voltage of the vehicle as ~~defined~~ specified by the vehicle manufacturer.**

## 1. Test setup and equipment

If a high voltage disconnect function is used, measurements are to be taken from both sides of the device performing the disconnect function.

However, if the high voltage disconnect is integral to the RESS or the energy conversion system and the high-voltage bus of the RESS or the energy conversion system is protected according to protection class IPXXB after following the impact crash test, measurements may be taken only between downstream of the device performing the disconnect function and electrical loads.

The voltmeter used in this test shall measure DC values and have an internal resistance of at least 10 MΩ.

~~Before the vehicle impact crash test, measure and record the high voltage bus voltage (Vb) (see figure 1) shall be measured and recorded to and confirm that it is within the operating voltage of the vehicle as defined specified by the vehicle manufacturer.~~

## 2. The following instructions may be used if voltage is measured.

After the impact crash test, determine the high voltage bus voltages (Vb, V1, V2) (see figure 1). If the RESS has exposed conductive parts, measure the voltage V3 between any exposed conductive parts of it and the electrical chassis.

~~The measurement shall be made at 5 seconds after the impact.~~

The voltage measurement shall be made not earlier than 5 seconds, but, not later than 60 seconds after the impact.

This procedure is not applicable if the test is performed under the condition where the electric power train is not energized.

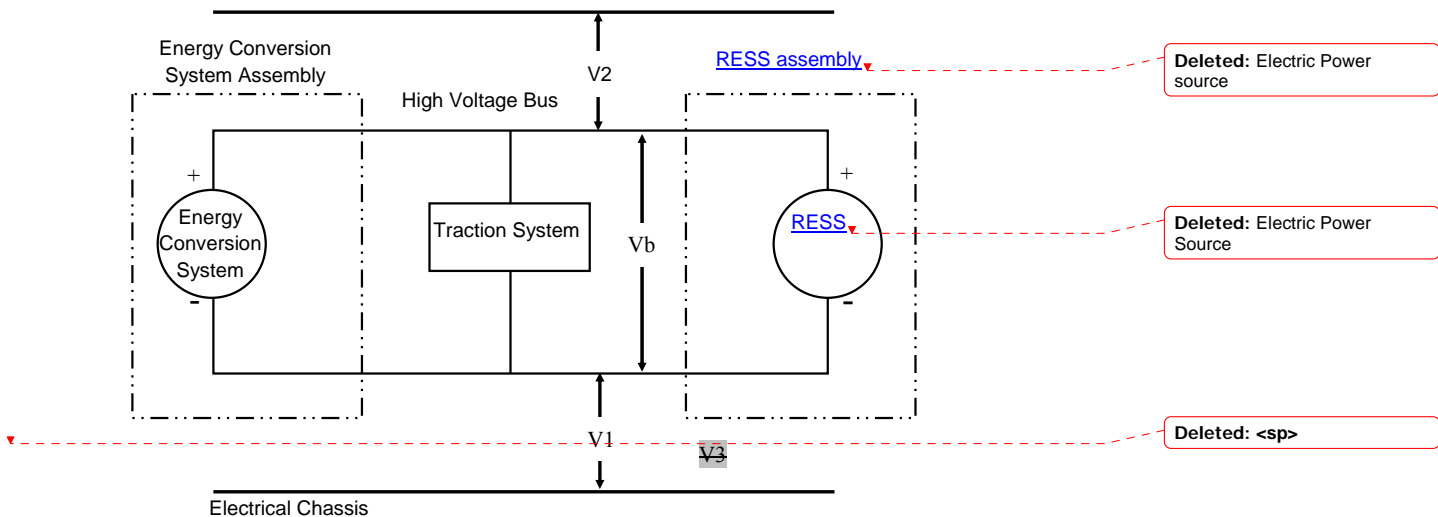

**Figure 1: Measurement of Vb, V1, V2, V3**

### 3. Assessment procedure for low electrical Energy

Prior to the impact a switch S1 and a known discharge resistor Re is connected in parallel to the relevant capacitance (ref. figure 2), installed according to figure 2.

Not earlier than 5 seconds and not later than 60 seconds after the impact the switch S1 shall be closed while the voltage Vb and the current Ie are measured and recorded. The product of the voltage Vb and the current Ie shall be integrated over the period of time, starting from the moment when the switch S1 is closed (tc) until the voltage Vb falls below the high voltage threshold of 30 V AC or 60 V DC (th). The resulting integration equals in the total energy (TE) in joules.

$$(a) \quad TE = \int_{t_c}^{t_h} V_b \times I_e dt$$

When Vb is measured at a point in time between 5 seconds and 60 seconds after the impact and the capacitance of the X-capacitors (Cx) is specified by the manufacturer, total energy (TE) shall be calculated according to the following formula:

$$(b) \quad TE = 0.5 \times C_x \times (V_b^2 - 3\,600 \text{ Volt}^2)$$

When V1, V2 (see figure 1) are measured at a point in time between 5 seconds and 60 seconds after the impact and the capacitances of the Y-capacitors (Cy1, Cy2) are specified by the manufacturer, total energy (TEy1, TEy2) shall be calculated according to the following formulas:

$$(c) \quad \begin{aligned} TE_{y1} &= 0.5 \times C_{y1} \times (V_1^2 - 3\,600 \text{ Volt}^2) \\ TE_{y2} &= 0.5 \times C_{y2} \times (V_2^2 - 3\,600 \text{ Volt}^2) \end{aligned}$$

This procedure is not applicable if the test is performed under the condition where the electric power train is not energized.

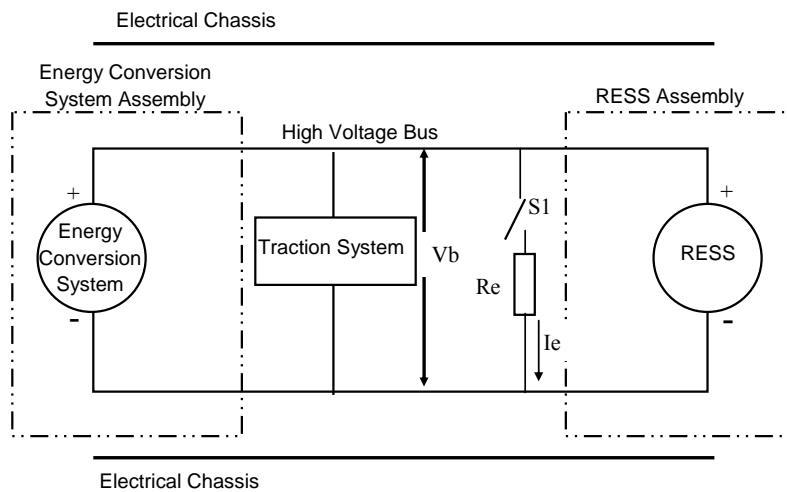

**Figure 2:** E.g. Measurement of high voltage bus energy stored in X-capacitors

#### 4. Physical Protection

~~The manufacturer shall define the physical barriers, enclosures and solid insulators that protect the human from the direct contact with the high voltage bus in use (hereinafter referred to as the 'original physical protection').~~

~~After crash~~ Following the vehicle impact test any ~~surrounding parts~~ surrounding of the high voltage components shall be, without the use of tools, ~~that can be opened, disassembled or removed. without the use of tools shall be opened, disassembled or removed. Only~~ All remaining ~~surrounding parts that cannot be opened, disassembled or removed without the use of tools are~~ shall be considered as a part of the ~~original~~ physical protection.

The Jointed Test Finger ~~access probe~~ described in Appendix 1 figure 1 ~~is pushed against~~ shall be inserted into any gaps or openings of the ~~original~~ physical protection with a ~~the~~ test force of  $10\text{ N} \pm 10\text{ per cent}$  for electrical safety assessment. If partial or full penetration ~~it partly or fully penetrates into the original physical protection~~ by the Jointed Test Finger ~~occurs, it is~~ the Jointed Test Finger shall be placed in every ~~possible~~ position as specified below.

Starting from the straight position, both joints of the test finger shall be rotated progressively ~~successively bent~~ through an angle of up to 90 degrees with respect to the axis of the adjoining section of the finger and shall be placed in every possible position.

Internal electrical protection barriers are considered part of the enclosure.

If appropriate a low-voltage supply (of not less than 40 V and not more than 50 V) in series with a suitable lamp should be connected, between the Jointed Test Finger and high voltage live parts inside the electrical protection barrier or enclosure.

##### 4.1. Acceptance conditions

The requirements of paragraph 5.3.6.1.3 shall be considered to be met if the Jointed Test Finger ~~access probe~~ described in Appendix 1, figure 1 ~~shall not~~ is unable to contact high voltage ~~touch~~ live parts.

If necessary A ~~a~~ mirror or a fiberscope may be used in order to inspect whether the ~~access probe~~ Jointed Test Finger touches the high voltage buses, ~~if necessary~~.

If this requirement is verified by a signal circuit between the Jointed Test Finger and high voltage live parts, the lamp shall not light.

#### 5. Isolation resistance

The isolation resistance between the high voltage bus and the electrical chassis may be demonstrated either by measurement or by a combination of measurement and calculation.

The following instructions ~~may~~ should be used if the isolation resistance is demonstrated by measurement.

~~[Before the vehicle crash test, measure and record the high voltage bus voltage (Vb) (see figure 1). Vb must be equal to or greater than the nominal operating voltage as defined by the vehicle manufacturer.]~~

~~[It is allowed to vehicle manufacturer to calculate or simulate this value instead of measuring this after the crash.]~~

Measure and record the voltage (Vb) between the negative and the positive side of the high voltage bus (see figure 1);

Measure and record the voltage (V1) between the negative side of the high voltage bus and the electrical chassis (see figure 1);

Measure and record the voltage (V2) between the positive side of the high voltage bus and the electrical chassis (see figure 1);

If V1 is greater than or equal to V2, insert a standard known resistance (Ro) between the negative side of the high voltage bus and the electrical chassis. With Ro installed, measure the voltage (V1') between the negative side of the high voltage bus and the vehicle electrical chassis (see figure 3). Calculate the isolation resistance (Ri) according to the formula shown below.

$$R_i = R_o * (V_b / V_1' - V_b / V_1) \quad \text{or} \quad R_i = R_o * V_b * (1 / V_1' - 1 / V_1)$$

Divide the result Ri, which is the this electrical isolation resistance value (in Ω), by the working voltage of the high voltage bus (in volts/Volt).

$$R_i \Omega / V = R_i \Omega / \text{Working voltage } V$$

$$R_i = R_o * (V_b / V_1' - V_b / V_1) \quad \text{or} \quad R_i = R_o * V_b * (1 / V_1' - 1 / V_1)$$

- Deleted: [ ]
- Deleted: [ ]
- Deleted: [ ]
- Deleted: [ ]
- Deleted: [ ]

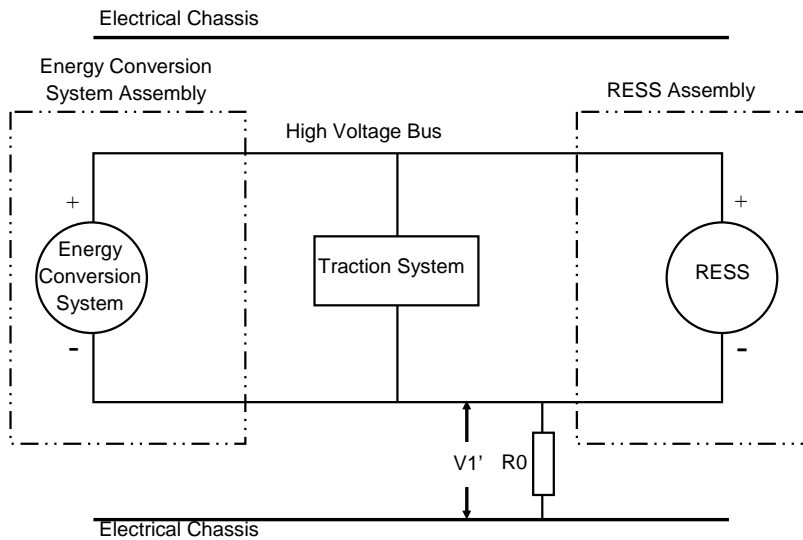

**Figure 3:** Measurement of V'1

If V2 is greater than V1, insert a standard known resistance (Ro) between the positive side of the high voltage bus and the electrical chassis. With Ro installed, measure the voltage (V2') between the positive side of the high voltage bus and the electrical chassis (see figure 4).

Calculate the isolation resistance (Ri) according to the formula shown below.

$$R_i = R_o * (V_b / V_2' - V_b / V_2) \quad \text{or} \quad R_i = R_o * V_b * (1 / V_2' - 1 / V_2)$$

Divide the result  $R_i$ , which is the ~~this~~ electrical isolation resistance value (in  $\Omega$ ), by the working voltage of the high voltage bus (in volts/Volt).

$$R_i \Omega / V = R_i \Omega / \text{Working voltage } V$$

$$R_i = R_o * (V_b / V_2' - V_b / V_2) \text{ or } R_i = R_o * V_b * (1 / V_2' - 1 / V_2)$$

- Deleted: ]
- Deleted: ]
- Deleted: ]
- Deleted: ]
- Deleted: ]
- Deleted: ]

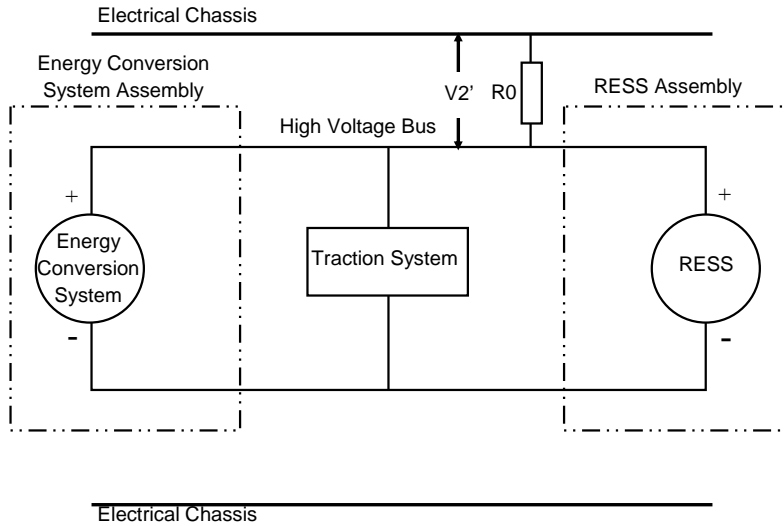

**Figure 4:** Measurement of  $V_2'$

**Note 1:** The standard known resistance  $R_o$  (in  $\Omega$ ) should be approximately 500 times the working voltage of the vehicle the value of the minimum required isolation resistance (in  $\Omega/V$ ) multiplied by the working voltage of the vehicle plus/minus 20 per cent (in volts/Volt).  $R_o$  is not required to be precisely this value since the equations are valid for any  $R_o$ ; however, an  $R_o$  value in this range should provide a good resolution for the voltage measurements.

The isolation resistance between the high voltage bus and the electrical chassis may be demonstrated by calculation, measurement or a combination of both.

#### 6. Electrolyte spillage

Appropriate coating paint shall be applied, if necessary, to the ~~original~~ physical protection in order to confirm the any electrolyte leakage is leaking from the RESS after the impact test collision.

Add color to other liquid (such as coolant, oil, fuel, etc.), if necessary, so that the electrolyte and other liquid can be classified or separated.

If the electrolyte cannot be clearly identified from the other leaking liquids, all liquid shall be considered as the electrolyte.

Unless the manufacturer provides means to differentiate between the leakage of different liquids, all liquid leakage shall be considered as the electrolyte.

## 7. RESS retention

Compliance shall be determined by visual inspection

### Appendix 1

#### JOINTED TEST FINGER (IPXXB)

##### Protection against direct contacts of parts under voltage

###### 1. Access probes

Access probes to verify the protection of persons against access to live parts are given in figure 1.

###### 2. Test conditions

The access probe is pushed against any openings of the enclosure with the force specified in paragraph 4 of this annex. If it partly or fully penetrates, it is placed in every possible position, but in no case shall the stop face fully penetrate through the opening.

Internal barriers are considered part of the enclosure

A low-voltage supply (of not less than 40 V and not more than 50 V) in series with a suitable lamp should be connected, if necessary, between the probe and live parts inside the barrier or enclosure.

The signal-circuit method should also be applied to the moving live parts of high voltage equipment.

Internal moving parts may be operated slowly, where this is possible.

###### 3. Acceptance conditions

The access probe shall not touch live parts.

If this requirement is verified by a signal circuit between the probe and live parts, the lamp shall not light.

In the case of the test for IPXXB, the jointed test finger may penetrate to its 80 mm length, but the stop face (diameter 50 mm x 20 mm) shall not pass through the opening. Starting from the straight position, both joints of the test finger shall be successively bent through an angle of up to 90 degree with respect to the axis of the adjoining section of the finger and shall be placed in every possible position.

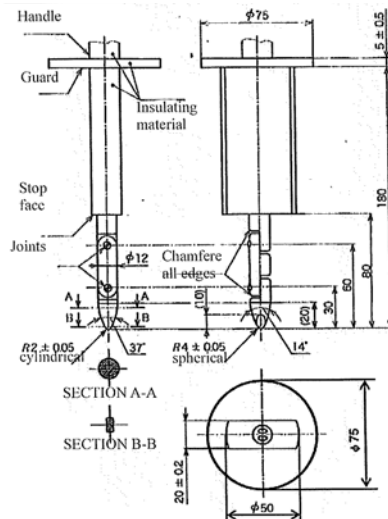

**Figure 1: Jointed test finger**

**Material: metal, except where otherwise specified**

**Linear dimensions in millimeters**

**Tolerances on dimensions without specific tolerance:**

- (a) on angles: 0/-10°
- (b) on linear dimensions: up to 25 mm: 0/-0.05 mm over 25 mm: ± 0.2 mm

**Both joints shall permit movement in the same plane and the same direction through an angle of 90° with a 0 to +10° tolerance.”**

## II. Justification

This proposal incorporates provisions in order to ensure that M<sub>1</sub> vehicles, as defined in the scope of Regulation No. 95, with power train systems above a certain working voltage level, comply with general requirements on the electrical safety, for the protection of occupants after a impact test. The electrical safety requirements are based on the 01 series of amendments to Regulation No. 100, Informal document No. GRSP-46-04 distributed during the forty-sixth session of the Working Party on Passive Safety (GRSP) and on the results of the discussions at the EVPC informal group meeting held in Bonn on 11-12 march 2010. Justifications on Rev A are given at the end of this document.

*Contents, new Annex 9 :*

A new annex is inserted to cover electrical safety requirements based on the 01 series of amendments to Regulation No. 100.

*Paragraph 2.2.8.:*

The place of the electrical source(s) has been introduced in the vehicle type definition as a new parameter to take into account.



*Paragraph 2.3.,2.3.1 and 2.3.2: passenger compartment*

The proposed amendment to this paragraph is needed with regard to the new provisions introduced for the passenger compartment for pure electrical safety aspects which are different from the original protection of occupants.

*New paragraphs 2.15. to 2.33.:*

New definitions used in the proposed amendment are inserted. They are in line with the 01 series of amendments to Regulation No. 100 and /or modified specifically for the electrical safety requirements for impact tests.

*New paragraph 3.2.6.:*

“Application for approval” is modified to include information on the rechargeable energy storage system (RESS) type and the location of the electric power train.

*New paragraph 5.3.6. introduced in 5.2:*

The proposed amendment to this paragraph introduces paragraph 5.3.6. to prescribe electrical requirements to fulfil electric vehicle safety. It also introduces the possibility for the manufacturer to perform a separate impact test for the assessment of electrical safety of electric vehicles.

*New paragraphs 5.3.6.1. to 5.3.6.1.4.2.:*

These paragraphs deal with:

(a) Electrical safety requirements;

Isolation resistance criteria, as defined in 5.3.6.1.4, is applicable only if more than a single potential of a part of the high voltage bus is not protected under the conditions of IPXXB, after post impact. This is to take into account possible risks where more than one part of the high voltage bus could become accessible, the isolation resistance criteria could not detect.

Devices having the same function as the automatic disconnect function have been also introduced as a possibility to isolate the electrical source (s). Application of 5.3.6.1.3 and 5.3.6.1.4 is only possible with the criteria physical protection or insulation resistance.

(b) Spillage requirements for RESS;

Electrolyte spillage in the passenger compartment is totally forbidden. Less than 7 % and 5 liters of the electrolyte shall spill outside the passenger compartment. 7% is a value already mentioned in the regulation R 12.

(c) Cells and RESS locations and retention.

The RESS shall stay in their original locations with their components inside and no intrusion into the passenger compartment for electric safety assessment is allowed.

Control of electrical safety prescriptions is satisfied if at least one the four following requirements is met:

(a) Absence of high voltage;

(b) Energy on high voltage bus less than 0.2 j; The value of 0.2 joules is to be discussed in GRSP.

- (c) Physical barrier protection IPXXB and resistance between the electrical chassis and all exposed conductive parts shall be less than 0.1 ohm;
- (d) Isolation resistance.

This proposal refers to the 01 series of amendments to Regulation No. 100 prescriptions considering separate or combined DC-AC buses to specify the minimum insulation resistance to achieve.

Modifications introduced reflect the state of discussions in the EVPC informal group.

*Annex 1,*

*Communication,*

*New paragraph 7.:*

The proposed information shall be added in the communication certificate.

*Annexe 2: update the example for the marking*

*Annex 4,*

*New paragraph 4.1.:*

This paragraph has been revised to allow performing tests with the fuel system modified to have the engine running (e.g. with an additional small fuel tank) or the electrical energy conversion system running.

*Paragraph 4.3.2.:*

Hydrogen storage systems initially introduced have to be taken into account in another regulation.

*New paragraphs 5.11. to 5.11.2.2.:*

These paragraphs describe the test conditions of the electric power train.

*New Annex 9 and Appendix 1:*

This annex describes the test setup, measuring equipment and the different test procedure that can be used for validation of the different options mentioned in paragraph 5.3.6.1.

- (a) Bus voltage
- (b) Isolation resistance
- (c) Electrical energy
- (d) Physical Barrier

Isolation resistance measurement and physical barrier protection requirements are in line with the 01 series of amendments to Regulation No. 100. Accordingly, Appendix 1 introduces the drawing of the jointed test finger the protection against direct contacts of parts under voltage.

Appendix 1: Text deleted in appendix 1 was transferred to paragraph 4 of the annex 9.

---

Justifications for additional amendments marked in italic

*Paragraph 5.5.1.2.. Low electrical energy*

The first amendment clarifies that the determination of energy with the X-capacitors value, together with Vb, is an alternative to test procedure mentioned in Annex 11. Furthermore, it was not described how the TE has to be calculated on the basis of the X-capacitors and Vb. A formula is also added to the annex and a hint to this is necessary here.

The second modification is to clarified that, in addition to TE, the total energy of the Y-capacitors has also to be checked whether it is below 0,2 Joule. This has to be checked for both voltages V1 and V2. It is also here necessary to add two formulas in annex 11 and to make here a hint to the formula in the annex.

*Paragraph 10, modify 10.9*

*“10.9 Contracting Parties may continue to apply the requirements with regard to electrical safety in the event of a frontal collision already in force for the categories that are not covered in this Regulation at the time of acceding to 03 series of amendments.”*

As the proposed 10.9 is not really necessary, we proposed to replace it by the above proposal to take into account a proposal from Japan.

*Annex 3, modify paragraph 5.11.2.1.*

These prescriptions allow that only parts of the system are not energized. Therefore it is possible that other parts are energized and it will not be possible to use for these parts the “voltage- or energy-option», according to the second part of the paragraph. Furthermore, in Annex 9, at the end of the test procedure for both dynamic measures, it is mentioned that this procedure is not applicable if the test is performed under the condition where the electric power train is not energized. Therefore, the second sentence has to be modified to allow this possibility.

*Annex 9*

It is likely that an active onboard isolation resistance monitoring system will not allow conducting the measurements. Therefore it is necessary to allow deactivating the system. This is also allowed in the new ECE R100.

*Annex 9, paragraph 1*

The measurement of Vb, which is showing that the right vehicle was crashed, should not been mentioned under the following topic “Test setup and equipment”. It is the understanding of the crash-experts that when it is mentioned there, it is not possible to conduct the test with the systems not energized but this is an allowed possibility. In addition, to make it clear that this requirement has to be checked before the impact test the word “conducted” is added.

*Annex 9, paragraph 3*

When after the impact test, no energy will be produce (e.g. recuperation), no AC V will be in the system. Therefore, when this is the case only DC Voltage has to be considered.  
(delete 30 VAC )

Formulas are those already mentioned under 5.3.6.1.2. The 3 600 Volt<sup>2</sup> are expressing the agreement that only the energy above 60 V has to be considered.

- ~~2.19.2.25.~~ **“Coupling system for charging the rechargeable energy storage system (RESS)”** means the electrical circuit used for charging the RESS from an external electrical power supply including the vehicle inlet,
- ~~2.20.2.21.~~ **“Direct contact”** means the contact of persons with high voltage live parts,
- ~~2.21.2.19.~~ **“Live parts”** means conductive part(s) intended to be electrically energized in normal use,
- ~~2.22.2.22.~~ **“Indirect contact”** means the contact of persons with exposed conductive parts,
- ~~2.23.2.23.~~ **“Protection IPXXB degree”** means the protection from contact with high voltage live parts provided by either an electrical protection barrier or an enclosure related to the contact with live parts by a test probe, such as a ~~Test Finger (IPXXB) or a test wire (IPXXD)~~ and tested using a Jointed Test Finger (IPXXB) or a test wire (IPXXD) as described defined in Appendix 1 paragraph 4 of Annex 9,
- ~~2.24.2.20.~~ **“Exposed conductive part”** means the conductive part which can be touched under the provisions of the protection degree IPXXB, and which becomes electrically energized under isolation failure conditions,
- ~~2.25.2.27.~~ **“Electrical circuit”** means an assembly of connected high voltage live parts which is designed to be electrically energized in normal operation,
- ~~2.26.2.24.~~ **“Working voltage”** means the highest value of an electrical circuit voltage root-mean-square (rms), specified by the manufacturer, which may occur between any conductive parts in open circuit conditions or under normal operating conditions. If the electrical circuit is divided by galvanic isolation, the working voltage is defined for each divided circuit, respectively,
- ~~2.27.2.26.~~ **“Electrical chassis”** means a set made of conductive parts electrically linked together, whose electrical potential is taken as reference,
- ~~2.28.2.17.~~ **“Electrical Protection Barrier” / Protection Shielding / Shielding / Barrier el/ High Voltage Protection”** means the part providing protection against any direct contact to the high voltage live parts from any direction of access,

- ~~2.30.2.15.~~ **“High Voltage”** means the classification of an electric component or circuit, if its working voltage is > 60 V and ≤ 1500 V direct current (DC) or > 30 V and ≤ 1000 V alternating current (AC) root – mean – square (rms),

**"Open type traction battery" means a liquid type battery requiring refilling with water and generating hydrogen gas released to the atmosphere.]**

Page 3: [4] Deleted

csd

5/19/2010 6:15:00 PM

~~Additionally,~~ vehicles equipped with electric power train shall meet the requirements of paragraph 5.3.6. ~~in addition.~~ This ~~can~~ ~~could~~ ~~be demonstrated in~~ ~~met~~ by a separate crash-impact test at the request of the manufacturer and after validation by the Technical Service, ~~given~~ ~~provided~~ that the electrical components do not influence the occupant protection performance of the vehicle type as defined in paragraphs 5.2.1. to 5.2.5. of this Regulation.}]”