

PROPOSAL FOR DRAFT AMENDMENTS TO REGULATION No. 11

Note: The text reproduced below was prepared by the expert from the European Commission in order to extend the scope to vehicles in categories N<sub>2</sub> and N<sub>3</sub> and add requirements on steps and running boards.

The text enclosed is based on that of EC Directives 98/90/EC and 2001/31/EC.

A PROPOSAL

Paragraph 1., amend to read:

"1. Scope

This Regulation applies to vehicles of categories M<sub>1</sub> and N 1/ with respect to ~~latches and door retention components such as hinges and other supporting means on~~ their doors, which can be used for the entry or exit of the occupants."

Paragraph 2.1., amend to read:

"2.1. "Approval of a vehicle" means the approval of a vehicle type with regard to **its doors**."

Insert new paragraphs 2.2.6.to 2.2.7., to read:

**"2.2.6. Construction and fitting requirements of the running boards and steps as regards vehicles not covered by Annex 7**

**2.2.7. Position and geometrical characteristics of the access steps and the handholds as regards vehicles mentioned in Annex 7."**

Paragraph 3.1., amend to read:

"3.1. The application for approval of a vehicle type with regard to **its doors** shall be submitted by the vehicle manufacturer or by his duly accredited representative."

Paragraph 3.2.2., amend to read:

"3.2.2. ...door retention components **and, if applicable, of the running boards, steps and handholds**."

Paragraph 4.2., amend to read:

"4.2. ... first two digits (**04**) shall indicate the..."

Insert new paragraphs 5.3. to 5.3.5., to read:

**"5.3. Running boards and steps (construction and fitting requirements)**

**5.3.1. The design characteristics of the vehicle must permit entry to and exit from it in perfect safety. Doors, entries and exits must be such that they can be used easily and without danger.**

**5.3.2. Vehicles of category N<sub>2</sub> with a maximum mass exceeding 7,5 tonnes and N<sub>3</sub> are deemed to satisfy the requirements as mentioned in paragraph 5.3.1. above if they comply with the prescriptions of Annex 7.**

**5.3.3. The wheel hub, rims and other parts of the wheel shall not be deemed to be running boards or steps for the purpose of this Regulation, except where reasons relating to construction or use preclude the fitting of running boards or steps elsewhere on the vehicle.**

**5.3.4. In vehicles of categories M<sub>1</sub>, N<sub>1</sub> and N<sub>2</sub> with a maximum mass not exceeding 7,5 tonnes if the floor entrance to the passenger compartment of such vehicles is more than 600 mm above the ground, the vehicle must have one or more running boards or steps.**

**5.3.4.1. However, for off-road vehicles, in conformity with the definitions given in the Consolidated Resolution on the Construction of Vehicles (R.E.3) (TRANS/WP.29/78/Rev.1/Amend.2, Annex 7/Rev.2), such a distance from the ground may be increased up to 700 mm.**

**5.3.5. The running boards or steps must be constructed in such a way as to preclude the risk of slipping."**

Paragraph 6., amend to read:

"6. ...Performance requirements **applicable to vehicles in categories M<sub>1</sub> and N<sub>1</sub>**"

Paragraph 7., amend to read:

"7. ...Test procedures **applicable to vehicles in categories M<sub>1</sub> and N<sub>1</sub> only**"

Paragraph 13.1., amend to read:

"13.1 ...force of the **04** series of amendments... ..amended by the **04** series of amendments."

Paragraph 13.2., amend to read:

"13.2 Until [**1 November 2012**], Contracting Parties applying this Regulation shall continue to grant approvals to those types of vehicles which comply with the requirements of this Regulation as amended by the preceding series of amendments."

Paragraph 13.3., amend to read:

"13.3. As from [1 November 2012], Contracting Parties applying this Regulation shall grant approvals only if the vehicle type to be approved meets the requirements of this Regulation as amended by the **04** series of amendments."

Paragraphs 13.4. to 13.7., amend to read:

"13.4. No Contracting Party applying this Regulation shall refuse national or regional type-approval of a vehicle type approved to the **04** series of amendments to this Regulation."

13.5. Until [1 November 2012], no Contracting Party applying this Regulation shall refuse national or regional type-approval of a vehicle type-approved to the preceding series of amendments to this Regulation.

13.6. As from [1 November 2012], Contracting Parties applying this Regulation may refuse first national or regional registration (first entry into service) of a vehicle which does not meet the requirements of the **04** series of amendments to this Regulation.

13.7. As from [1 November 2014], approvals to this Regulation shall cease to be valid, except in the case of vehicle types which comply with the requirements of this Regulation as amended by the **04** series of amendments."

Annex 1, amend to read:

"...with regard to **the doors** pursuant to Regulation..."

Insert a new Annex 7, to read:

#### **"Annex 7**

#### **REQUIREMENTS CONCERNING THE ACCESS TO AND EXIT FROM THE DOORS OF THE DRIVER'S COMPARTMENT OF VEHICLES OF CATEGORY N2 HAVING A MAXIMUM MASS EXCEEDING 7,5 TONNES AND OF CATEGORY N3**

- 1. Access steps to the driver's compartment (see figure 7-1)**
  - 1.1. The distance (A) from the ground to the upper surface of the lowest step, measured with the vehicle in running order on a horizontal and flat surface, shall not be more than 600 mm.**
    - 1.1.1. However, for off-road vehicles, in conformity with the definitions given in the Consolidated Resolution on the Construction of Vehicles (R.E.3) (TRANS/WP.29/78/Rev.1/Amend.2, Annex 7/Rev.2), that distance (A) may be increased up to 700 mm.**
  - 1.2. The distance (B) between the upper surfaces of the steps shall be not more than 400 mm. The vertical distance between two subsequent steps shall not vary by more than 50 mm. The last requirement shall not apply to the distance between the uppermost step and the cab floor.**

- 1.2.1. However, for off-road vehicles, in conformity with the definitions as mentioned above (see 1.1.1.), this latter figure may be increased up to 100 mm.
- 1.3. In addition, the following minimum geometrical specifications shall be fulfilled:
  - (a) step depth (D): 80 mm
  - (b) step clearance (E) (include step depth): 150 mm
  - (c) step width (F): 300 mm
  - (d) width of the lowest step (G): 200 mm
  - (e) step height (S): 120 mm
  - (f) transversal offset between steps (H): 0 mm
  - (g) longitudinal overlap (J) between two subsequent steps in the same flight, or between the uppermost step and the cab floor: 200 mm.
- 1.3.1. However, for off-road vehicles (see 1.1.1.) the value (F) may be reduced to 200 mm.
- 1.4. The lowest step may be designed as a rung, if this is necessary for reasons relating to construction or use, and in the case of off-road vehicles, in conformity with the definitions as mentioned above. In such case the rung depth (R) shall be at least 20 mm.
  - 1.4.1. Rungs of round cross section are not permitted.
- 1.5. While getting down from the driver's compartment the position of the uppermost step shall be easily found out.
- 1.6. The upper surface of the steps shall be non-slip. In addition, steps exposed to the weather and the dirt during driving shall have adequate run-off (draining surface).
2. Access to handholds to the driver's compartment (see figure 7-1)
  - 2.1. One or more suitable handrails and handholds or other equivalent holding devices shall be provided for the access to the driver's compartment.
    - 2.1.1. The handrail(s) or handholds or equivalent holding devices must be positioned in such a way that they can be easily grasped and do not obstruct access.
    - 2.1.2. A maximum discontinuity of 100 mm in the holding area of the handrails or handholds or equivalent holding devices may be allowed (for instance intermediate fixation).
    - 2.1.3. In the case of access with more than two steps the handrails, handholds or equivalent holding devices shall be located so that a person may support himself at the same time at three points (with two hands and one foot or with two feet and one hand).
    - 2.1.4. Except in the case of a stairway, the design and positioning of the handrails, handholds and equivalent holding devices must be such that operators are encouraged to descend facing the cab.

- 2.1.5. The steering wheel may be considered as a handhold.
- 2.2. The height (N) of the lower edge of at least one handrail or handhold or equivalent holding device, measured from the ground with the vehicle in running order on a horizontal and flat surface, shall not be more than 1 850 mm.
- 2.2.1. However, for off-road vehicles (see 1.1.1), such distance (N) may be increased up to 1 950 mm.
- 2.2.2. If the floor of the driver's compartment has a height from the ground greater than "N", this height shall be assumed as "N".
- 2.2.3. In addition, the minimum distance (P) of the upper edge of the handrail(s) or handholds or equivalent holding devices from the floor of the driver's compartment shall be:
- (a) handrail(s) or handholds or equivalent holding devices (U) 650 mm,
  - (b) handrail(s) or handholds or equivalent holding devices (V) 550 mm.
- 2.3. The following geometrical specifications shall be fulfilled:
- (a) gripping dimension (K): 16 mm minimum 38 mm maximum,
  - (b) length (M): 150 mm minimum,
  - (c) clearance to vehicle components (L): 40 mm minimum with open door.

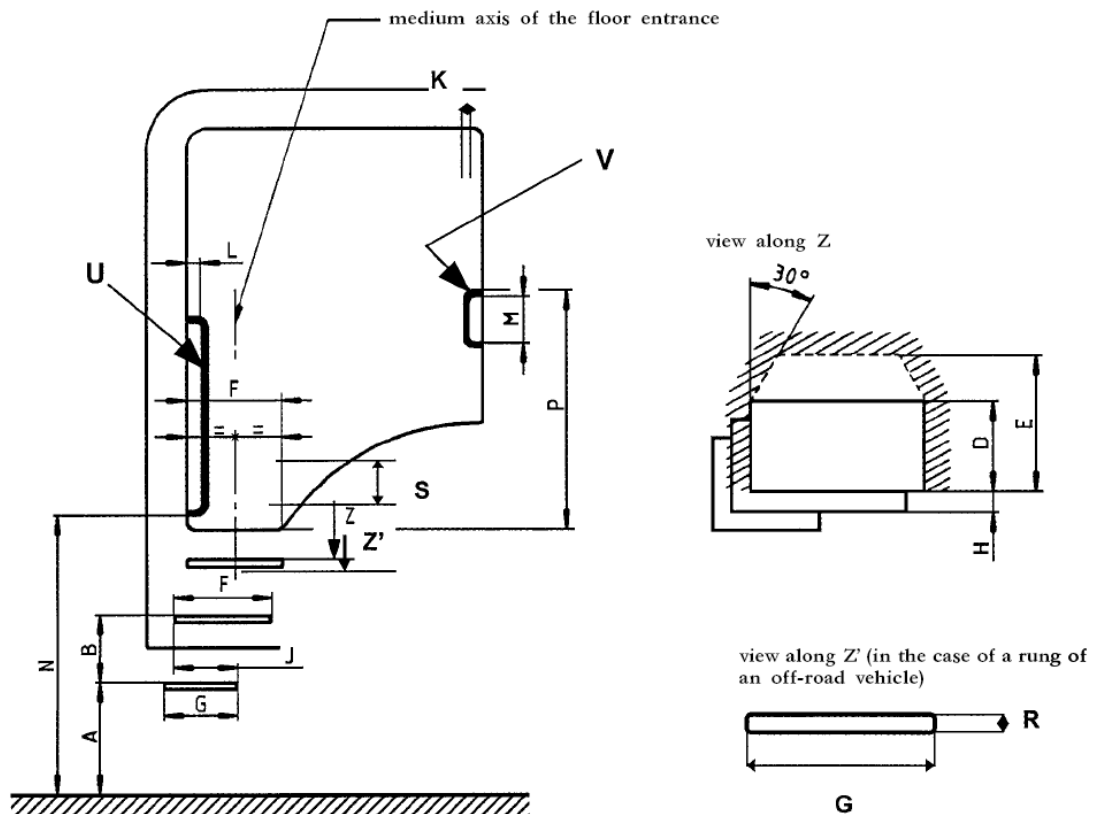

Figure 7-1

3. **In the case of a sloped floor of the driver's compartment the required measurements shall be made from a horizontal plane passing through a point which is given by the intersection of the front edge of the floor with a vertical plane through the centre of the step immediately below and which is perpendicular to the longitudinal medium plane of the vehicle."**

## B JUSTIFICATION

This proposal incorporates provisions for vehicles in categories N2 and N3 in order to ensure that they comply with general requirements on the safety of doors, without, however, submitting them to the test procedures foreseen for vehicles in categories M1 and N1.

The proposal also introduces requirements for steps in those cases where the height from the ground to the passenger compartment is relatively high. A high step-up can have adverse health implications due to loading of limbs and joints. It is, therefore, important that such high step comply with specific ergonomic criteria in order to ensure the overall safety of vehicle occupants and to minimise the risk of fall upon entry or egress. The legislation on access to passenger compartments of vehicles has been in force in the European Union for more than 10 years. Drivers and other vehicle users will benefit from the application of the new requirements.

-----